

garford

providing advanced technology for progressive farming



SPARE PARTS MANUAL ROBOCROP INROW WEEDER

Garford Farm Machinery Ltd
Frognall
Deeping St James
Peterborough
PE6 8RP

Tel. 01778 342642
Fax. 01778 348949
Email. info@garford.com spares@garford.com

Revised October 2014 (Version 1)

THANK YOU FOR PURCHASING A garford PRODUCT.

**THIS BOOK CONTAINS THE FULL WORKING DRAWINGS OF THE MACHINE
WITH EVERY PART AND ASSOCIATED NUMBER LISTED. THIS QUICKLY
AND EASILY ALLOWS ANY PART OF THE MACHINE TO BE PIN POINTED IF
IT REQUIRES MAINTENANCE OR REPAIR.**

**FOR ANY OTHER ENQUIRIES OR QUESTIONS PLEASE D NOT HESITATE TO
CONTACT US.**

TEL :- +44 (0)1778 342642

FAX :- +44 (0)1778 348949

EMAIL :- info@garford.com

WEB :- www.garford.com

POSTAL ADDRESS :-

**Garford Farm Machinery Ltd
Frognall
Deeping St James
Peterborough
PE6 8RR
England**



PARTS BOOK SUB SECTION CONTENTS

SIDE SHIFT PARTS SECTION

FOLDING FRAMES & TOOL ARMS SECTION

CONTROL SYSTEM PARTS SECTION

ADJUSTABLE WHEEL UNIT PARTS SECTION

CULTIVATING PARTS SECTION

SIDE SHIFT PARTS SECTION

CONTENTS

	PAGE
ROBOCROP STANDARD DUTY “FREESHIFTING” SIDE SHIFT ASSEMBLY	1-2
ROBOCROP HEAVY DUTY “FREESHIFTING” SIDE SHIFT ASSEMBLY	3-4
ROBOCROP SIDE SHIFT GUARDS	5-6
ROBOCROP SIDE SHIFT / MACHINE STANDS	7-8
ROBOCROP FRONT LIFT ASSEMBLY	9-10

<CLICK> TO RETURN TO MAIN SUB SECTION CONTENTS PAGE

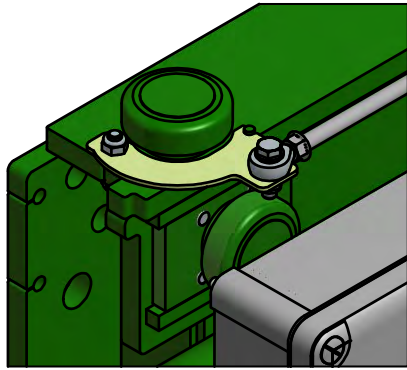

CROPED VIEW SHOWING POTENTIOMETER
RAM CONNECTED TO POTENTIOMETER SLIDE.

7517.00 - PART NUMBER FOR
ROLLER IN ITEM 3. AVAILABLE
AS A SPARE PART.

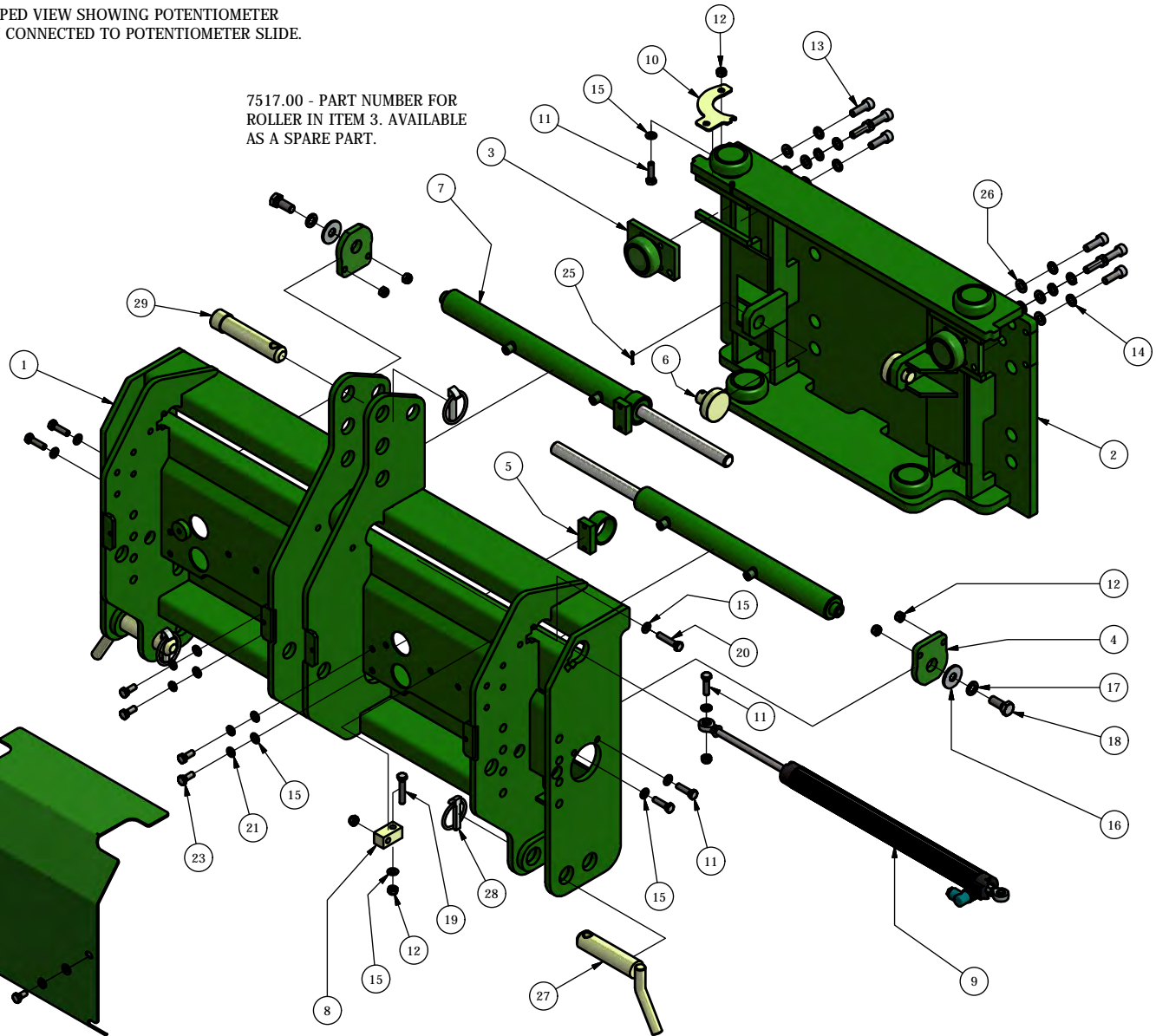

1

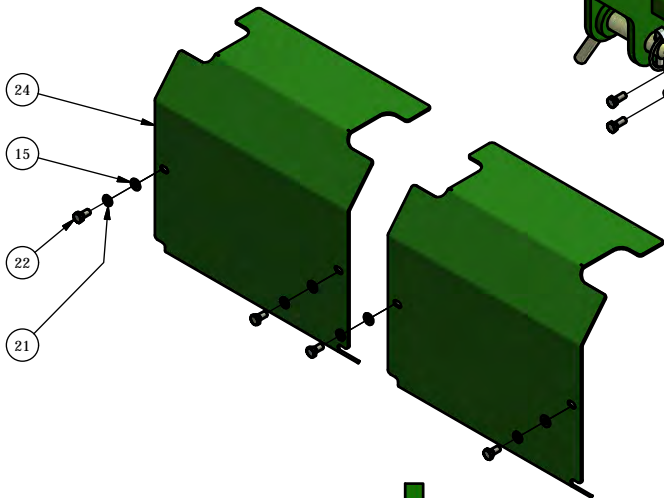

COVER REMOVED SHOWING POTENTIOMETER
RAM CONNECTED TO POTENTIOMETER BRACKET.

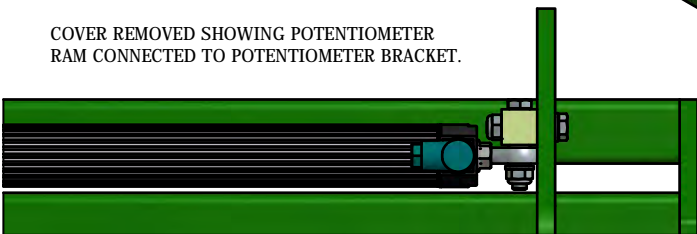

WITH EXCEPTION TO HYDRAULIC RAMS, RAM SUPPORTS &
BUFFERS, PARTS ARE INTERCHANGEABLE WITH THE
ROBO SIDESHIFT ASSEMBLY.

ROBOCROP STANDARD DUTY SIDESHIFT ASSEMBLY
“FREESHIFTING”

ITEM No.	DESCRIPTION	PART No.	QUANTITY
1	SIDE SHIFT FRAME	8605.00	1
2	SIDE SHIFT ROLLING FRAME	8606.00	1
3	SIDE SHIFT BOLT ON ROLLER & PLATE	7430.00	2
4	SIDE SHIFT RAM MOUNT	8464.04	2
5	RAM CENTERING SUPPORT	8816.00	2
6	SIDE SHIFT CENTERING RAM BUFFER	8734.00	2
7	HYDRAULIC RAM	8733.00	2
8	POTENTIOMETER CYLINDER END BRACKET	8461.00	1
9	POTENTIOMETER RAM	7732.00	1
10	POTENTIOMETER ARM BRACKET	8608.00	1
11	M8x25 BOLT BZP	1041	6
12	M8 NYLOC NUT BZP	1042	8
13	SOCKET CAP SCREW M10x30 BZP	6370	8
14	M10 SPRING WASHER BZP	1170	8
15	M8 FLAT WASHER BZP	1157	16
16	LARGE OD FLAT WASHER 12x37x3 BZP		2
17	M12 SPRING WASHER BZP	1115	4
18	M12x30 BOLT BZP	1161	2
19	M8x45 BOLT BZP	8825	1
20	M8x40 BOLT BZP	5834	1
21	M8 SPRING WASHER BZP	1154	8
22	M8x16 BOLT BZP	1156	4
23	M8x20 BOLT BZP	5738	4
24	SIDE SHIFT GUARD	8460.00	2
25	SPLIT PIN		2
26	M10 FLAT WASHER BZP	1186	8
27	LOWER LINK PIN	6409.00	2
28	LINCH PIN	5604.00	3
29	TOP LINK PIN	5442.00	1

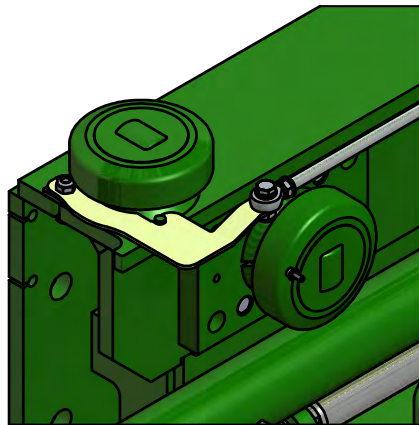

CROPPED VIEW SHOWING POTENTIOMETER
RAM CONNECTED TO POTENTIOMETER SLIDE.

9004.00 - PART NUMBER FOR
ROLLER IN ITEM 3. AVAILABLE
AS A SPARE PART.

3

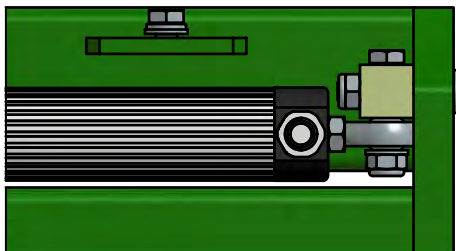
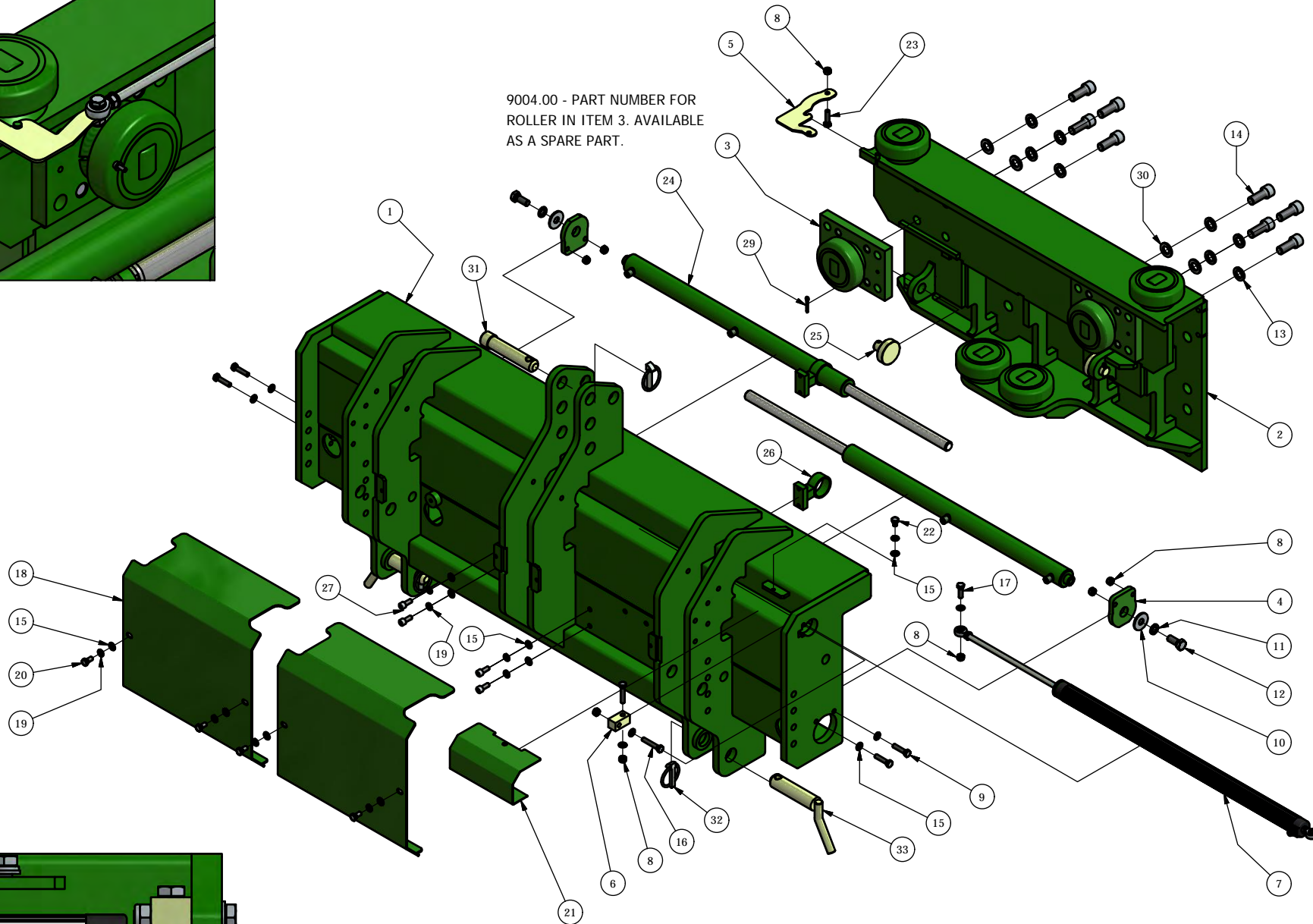

COVER REMOVED SHOWING POTENTIOMETER
RAM CONNECTED TO POTENTIOMETER BRACKET.

WITH EXCEPTION TO HYDRAULIC RAMS, RAM SUPPORTS &
BUFFERS, PARTS ARE INTERCHANGEABLE WITH THE
ROBO HEAVY DUTY SIDESHIFT.

ROBOCROP HEAVY DUTY SIDESHIFT ASSEMBLY
“FREESHIFTING”

ITEM No.	DESCRIPTION	PART No.	QUANTITY
1	H/D SIDE SHIFT FRAME	9001.00	1
2	H/D SIDE SHIFT ROLLING FRAME	9002.00	1
3	SIDE SHIFT BOLT ON ROLLER & PLATE	9003.00	2
4	SIDE SHIFT RAM MOUNT	8464.04	2
5	POTENTIOMETER ARM BRACKET	9006.00	1
6	POTENTIOMETER CYLINDER END BRACKET	8461.00	1
7	POTENTIOMETER RAM	8227.00	1
8	M8 NYLOC NUT BZP	1042	8
9	M8x35 BOLT BZP	7463	4
10	LARGE OD WASHER 12x37x3 BZP		2
11	M12 SPRING WASHER BZP	1115	2
12	M12x30 BOLT BZP	1161	2
13	M16 SPRING WASHER BZP	1119	8
14	SOCKET CAP SCREW M16x40 BZP	9067	8
15	M8 FLAT WASHER BZP	1157	16
16	M8x45 BOLT BZP	8825	1
17	M8x25 BOLT BZP	1041	1
18	SIDE SHIFT GAURD	9005.00	2
19	M8 SPRING WASHER BZP	1154	9
20	M8x16 BOLT BZP	1156	4
21	POTENTIOMETER COVER	9007.00	1
22	M8x10 BOLT BZP		1
23	M8x30 BOLT BZP	1153	1
24	HYDRAULIC RAM	9200.00	2
25	SIDE SHIFT CENTERING RAM BUFFER	8734.00	2
26	RAM CENTERING SUPPORT	9201.00	2
27	SOCKET CAP SCREW M8x20 BZP	6866	4
28	M8x40 BOLT BZP	5834	1
29	SPLIT PIN		2
30	M16 FLAT WASHER BZP	7878	8
31	TOP LINK PIN	5442.00	1
32	LINCH PIN	5604.00	3
33	LOWER LINK PIN	6409.00	2

5

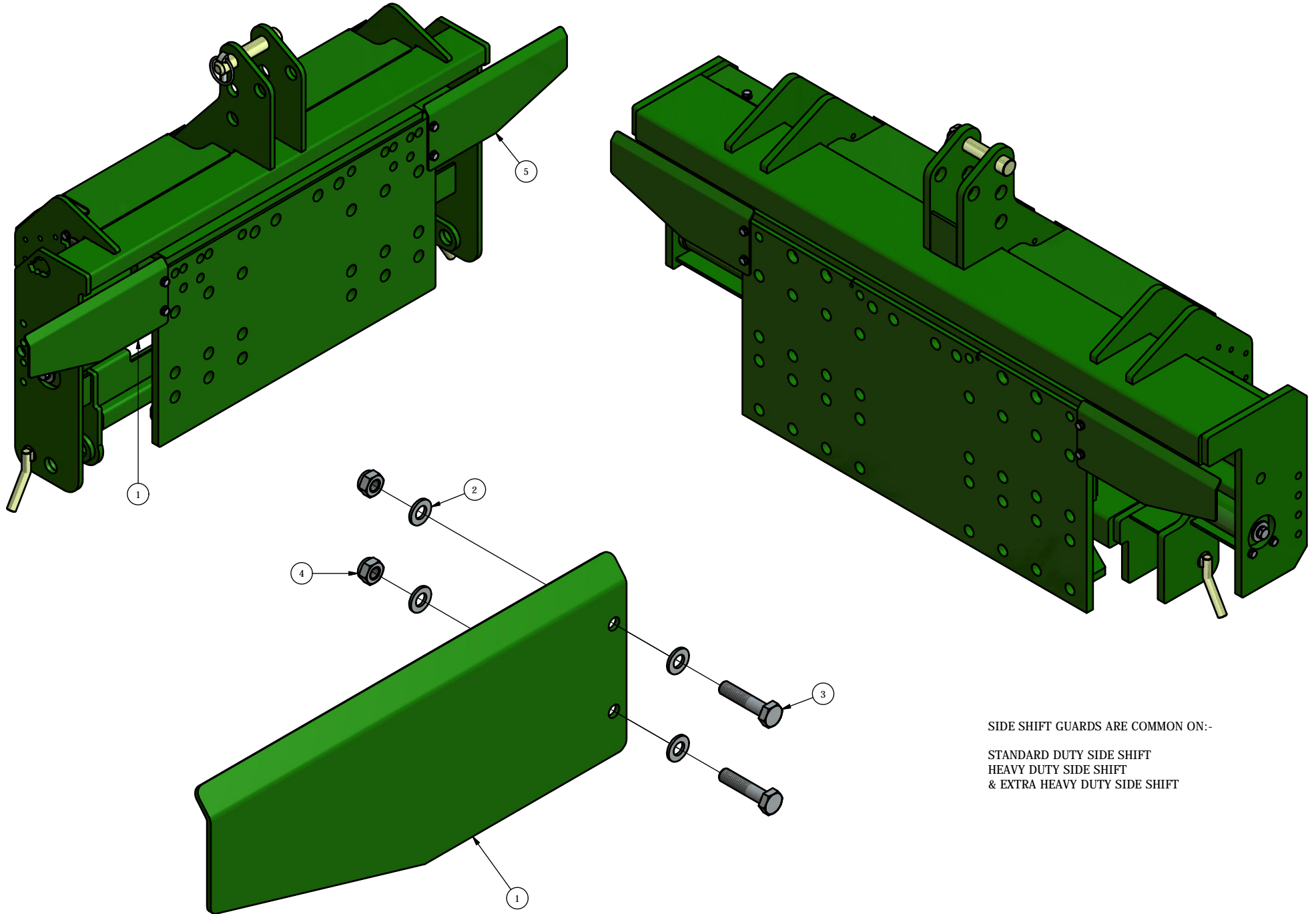

SIDE SHIFT GUARDS ARE COMMON ON:-
STANDARD DUTY SIDE SHIFT
HEAVY DUTY SIDE SHIFT
& EXTRA HEAVY DUTY SIDE SHIFT

ROBOCROP SIDE SHIFT GUARDS

ITEM No.	DESCRIPTION	PART No.	QUANTITY
1	LH GUARD	9854.00	1
2	M8 WASHER BZP	1157	8
3	M8x35 BOLT BZP	7463	4
4	M8 NYLOC NUT BZP	1042	4
5	RH GUARD	9853.00	1

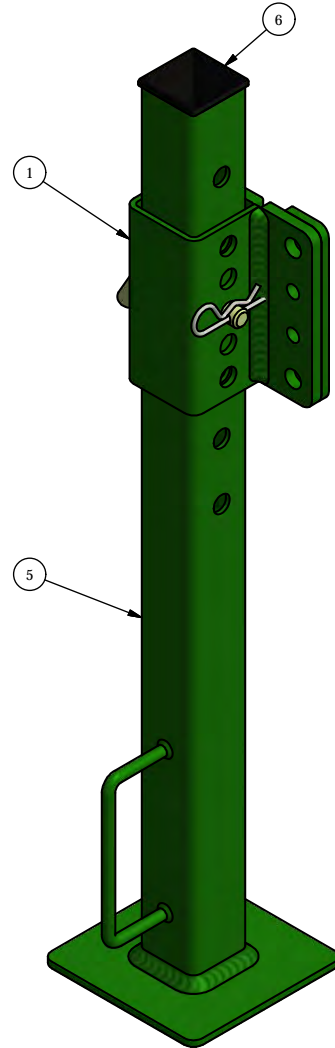
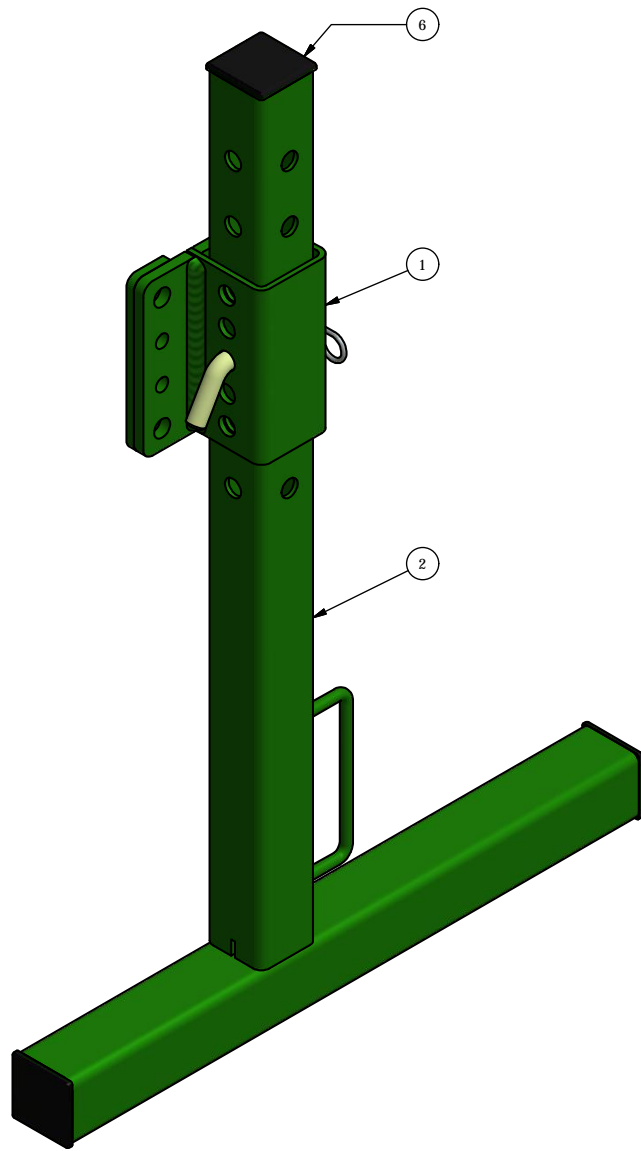

CROPPED SIDE VIEW OF MOUNTING BRACKET.

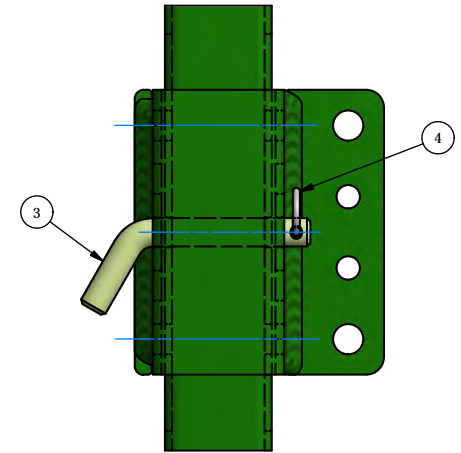

ROBOCROP SIDE SHIFT / MACHINE STANDS

ITEM No.	DESCRIPTION	PART No.	QUANTITY
1	STAND BRACKET	9251.00	1
2	'T' LEG STAND	9253.00	1
3	PIN	9265.00	1
4	R-CLIP	1067.00	1
5	STAND	9252.00	1
6	END CAP	7583.00	
	(END CAP QTY DEPENDENT ON STAND STYLE)		

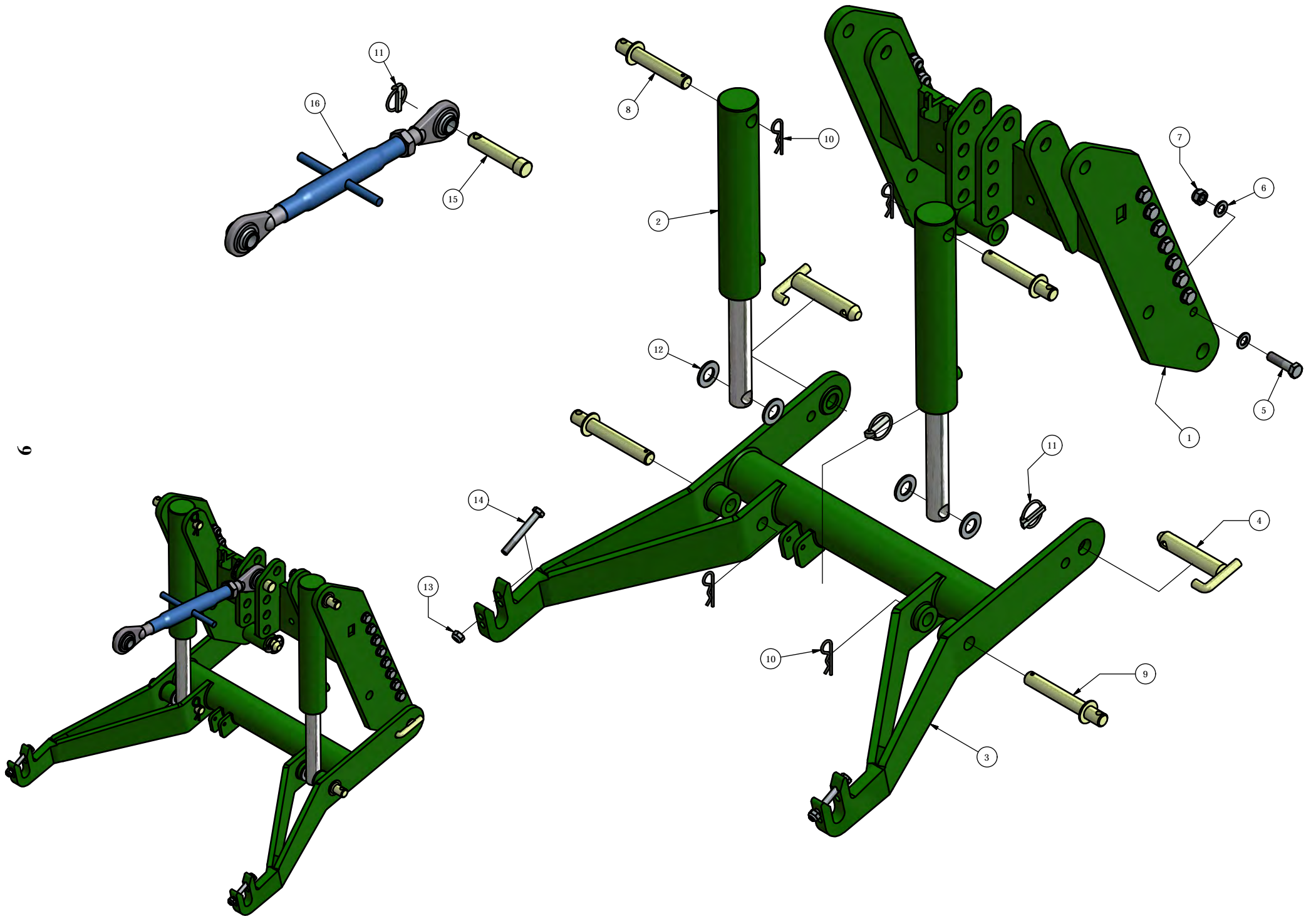

ROBOCROP FRONT LIFT ASSEMBLY

ITEM No.	DESCRIPTION	PART No.	QUANTITY
1	MAIN FRAME	5941.00	1
2	HYDRAULIC RAM	5985.00	2
3	FRONT LIFT ARMS	5942.00	1
4	PIVOT PIN	5946.00	2
5	M16x60 BOLT BZP	1176	16
6	M16 FLAT WASHER BZP	7878	32
7	M16 NYLOC NUT BZP	1030	16
8	HYDRAULIC RAM PIN	8140.00	2
9	HYDRAULIC RAM PIN	8139.00	2
10	R-CLIP 4mm	1067	4
11	RETAINING PIN	5604.00	3
12	M26 FLAT WASHER BZP		4
13	M12 NYLOC NUT BZP	1017	2
14	M12x90 BOLT BZP	1178	2
15	TOP LINK PIN	5442.00	1
16	TOP LINK	6784	1

FOLDING FRAMES & TOOL ARMS SECTION

CONTENTS

	PAGE
ROBOCROP 6M FOLDING FRAME	1-2
ROBOCROP PLUG IN FRAME EXTENSIONS	3-4
ROBOCROP FRONT BRIDGE FOR 6M FOLDING FRAME	5-6
ROBOCROP FIXED FRONT BRIDGE / TOOL ARM	7-8
ROBOCROP DISK STEER FRAME BEAMS	9-10

<CLICK> TO RETURN TO MAIN SUB SECTION CONTENTS PAGE

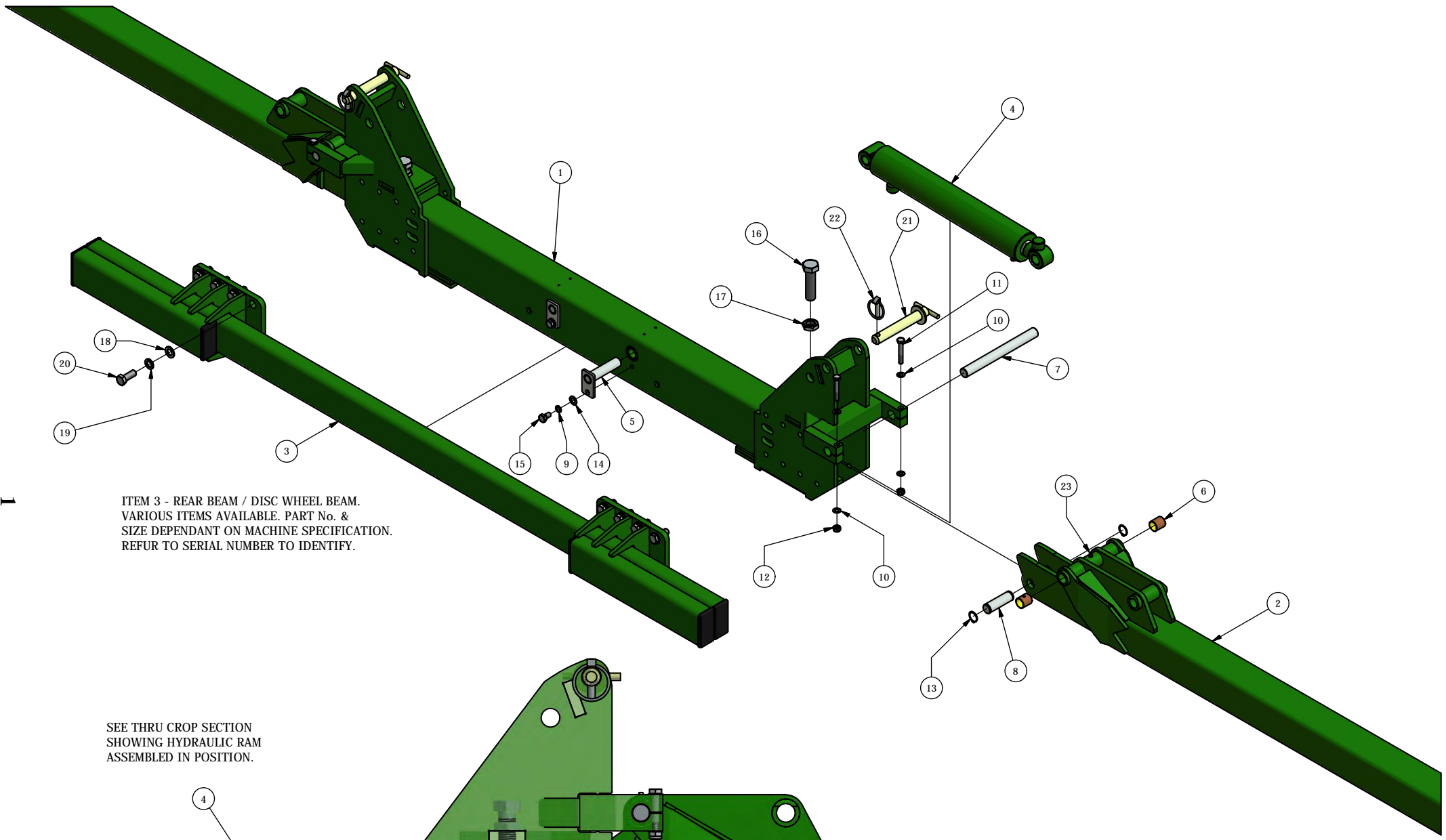

ITEM 3 - REAR BEAM / DISC WHEEL BEAM.
 VARIOUS ITEMS AVAILABLE. PART No. &
 SIZE DEPENDANT ON MACHINE SPECIFICATION.
 REFUR TO SERIAL NUMBER TO IDENTIFY.

SEE THRU CROP SECTION
 SHOWING HYDRAULIC RAM
 ASSEMBLED IN POSITION.

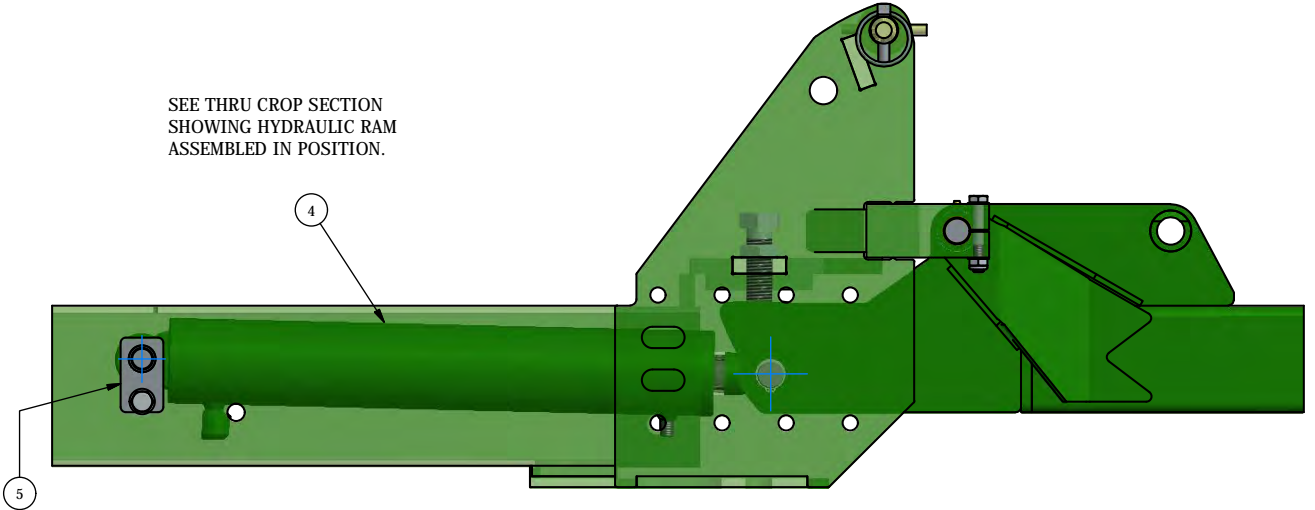

ROBOCROP 6M FOLDING FRAME

ITEM No.	DESCRIPTION	PART No.	QUANTITY
1	6M CENTRE SECTION	8577.00	1
2	6M FOLDING FRAME WING	8578.01	2
3	REAR BEAM / DISC WHEEL BEAM		1
4	HYDRAULIC RAM	8579.00	2
5	RAM RETAINING PIN	7417.00	2
6	BUSH	7446.00	4
7	FOLDING PIVOT PIN	7395.00	2
8	RAM PIN	8582.00	2
9	M12 SPRING WASHER BZP	1115	2
10	M10 FLAT THIN WASHER BZP	7876	8
11	M10x65 BOLT BZP	7459	4
12	M10 NYLOC NUT BZP	1024	4
13	25MM EXTERNAL CIRCLIP	7453	4
14	M12 THIN WASHER BZP	7877	2
15	M12x25 BOLT BZP	1111	2
16	M24x90 SET SCREW BZP	8835	2
17	M24 NUT BZP	8207	2
18	M16 FLAT WASHER BZP	7878	16
19	M16 SPRING WASHER BZP	1119	16
20	M16x40 BOLT BZP		16
21	TRANSPORT SAFETY PIN	8526.00	2
22	LINCH PIN	5604.00	2
23	GREASE NIPPLE 1/4" UNF		2

3

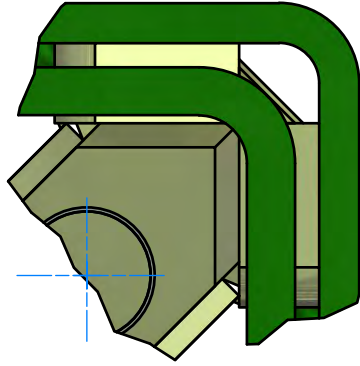
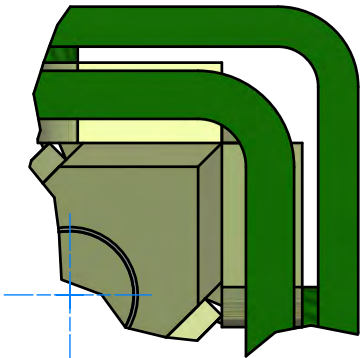
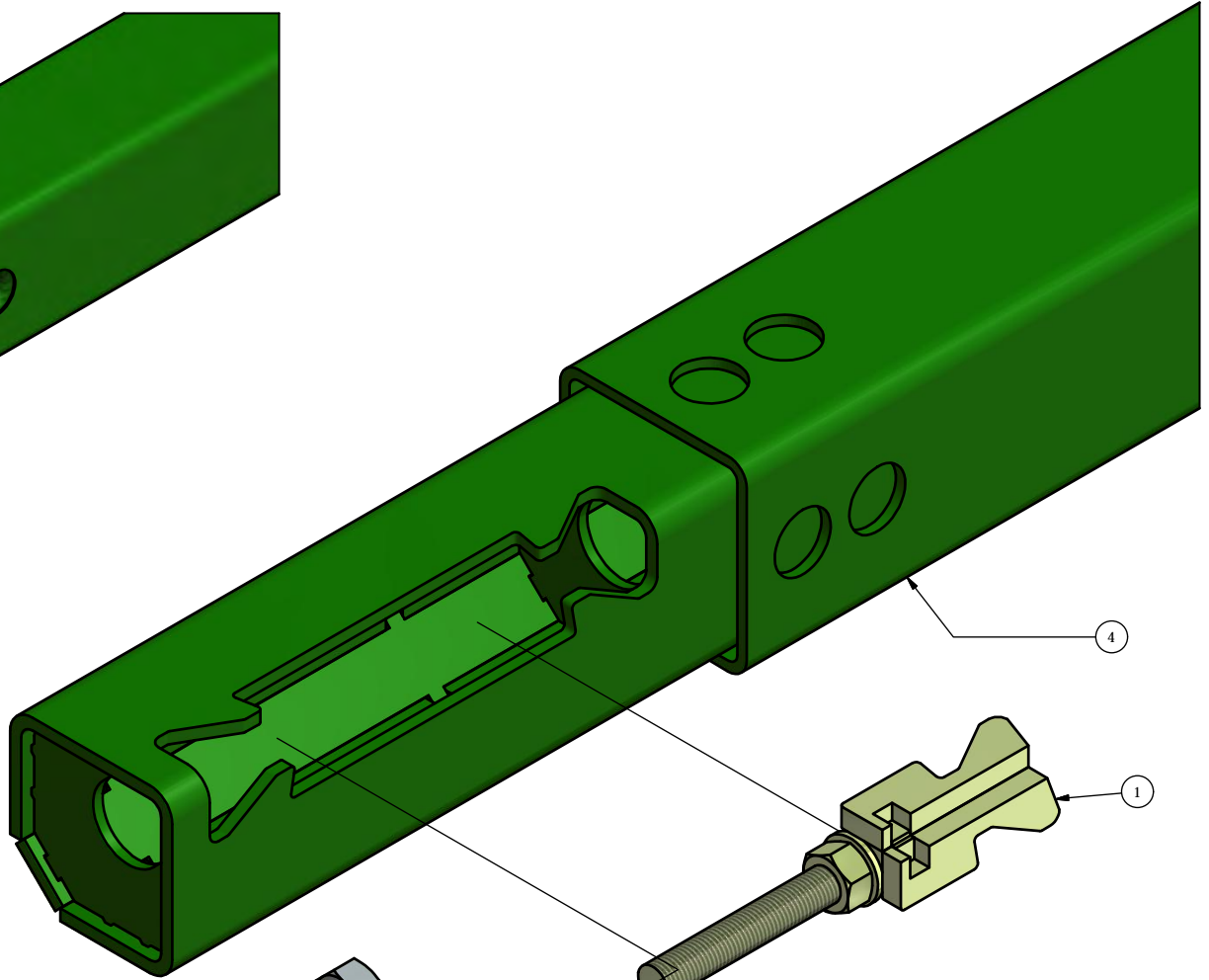
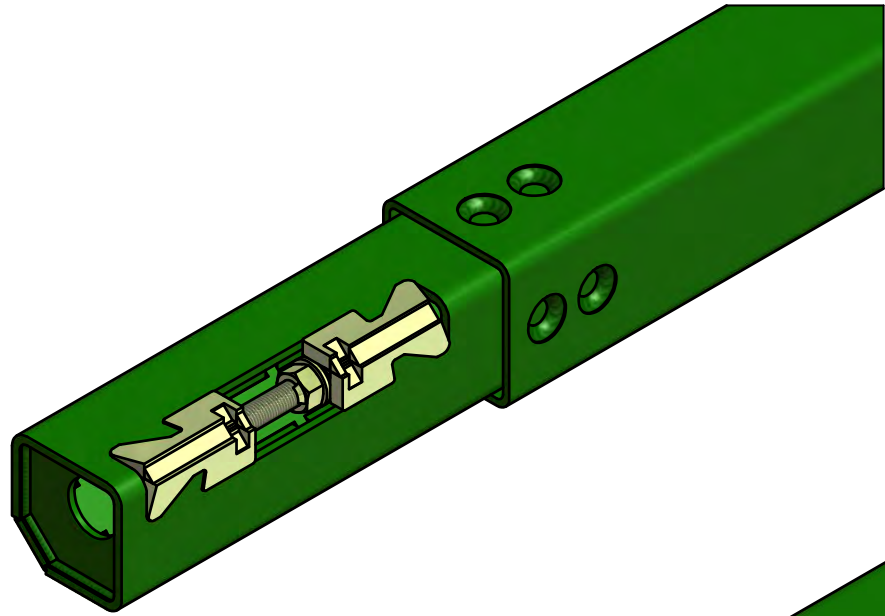

CROPPED END VIEWS SHOWING THE
EXTENSION WEDGE BEFORE BEING
TIGHTENED AND AFTER TIGHTENING
INTO PLACE.

ROBOCROP PLUG IN FRAME EXTENSIONS

ITEM No.	DESCRIPTION	PART No.	QUANTITY
1	PLUG IN EXTENSION WEDGE	9048.00	1
2	PLUG IN FRAME WEDGE	9049.00	1
3	M16 NUT BZP	1015.00	1
4	PLUG IN FRAME EXTENSION	9047.02	1

5

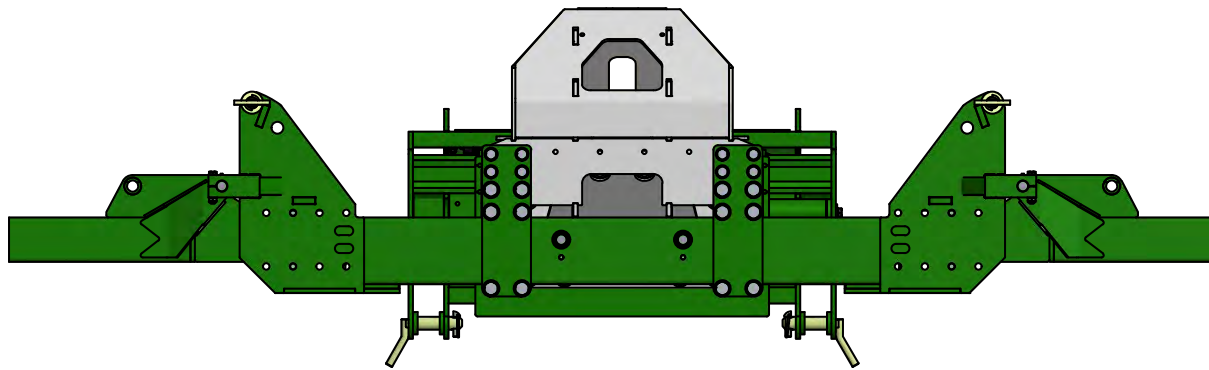
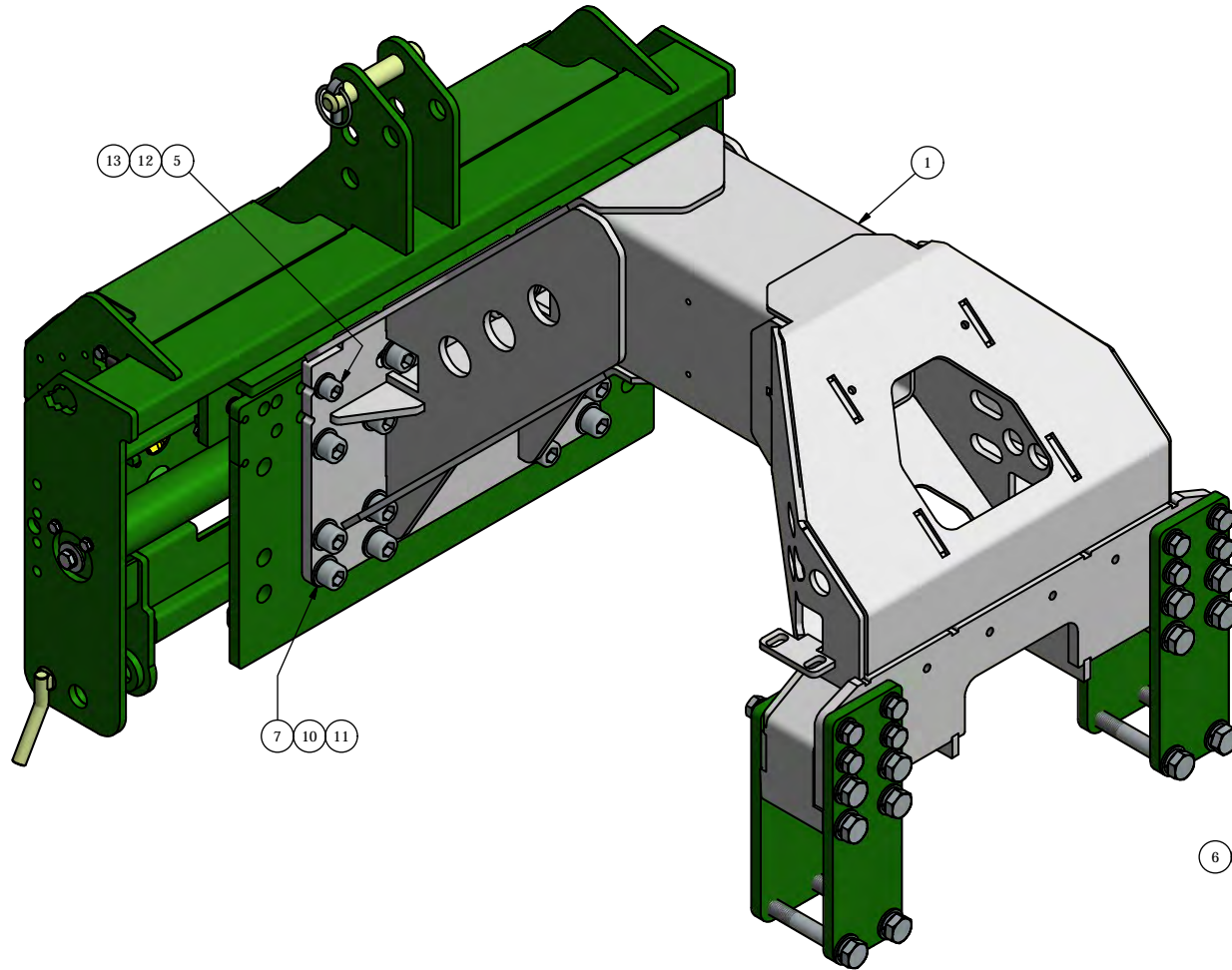

CROP VIEW OF BRACKETS IN PLACE ON FOLDING FRAME.

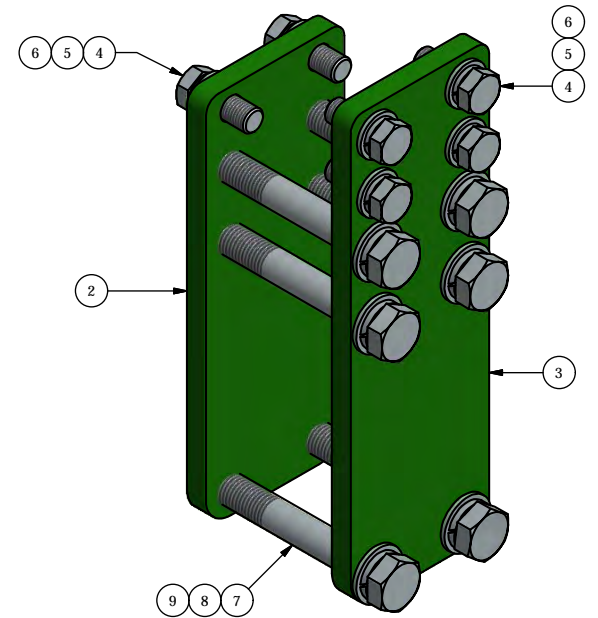

ROBOCROP FRONT BRIDGE FOR 6M FOLDING FRAME

ITEM No.	DESCRIPTION	PART No.	QUANTITY
1	FRONT PICK UP / CENTRE BRIDGE (VARIOUS LENGTHS)		
	900MM	10351.00	
	1100MM	10119.01	
	1250MM	10165.00	
	1450MM	10164.00	
2	FRONT PICK UP BRIDGE TO 6M FRAME		
	PLATE REAR	10159.00	1
3	FRONT PICK UP BRIDGE TO 6M FRAME		
	PLATE FRONT	10158.00	1
4	M16 SPRING WASER BZP		16
5	M16 WASHER BZP		12
6	M16x40 BOLT BZP		12
7	M20 WASHER BZP		44
8	M20 SPRING WASHERS BZP		12
9	M20x140 BOLT BZP		12
10	M20 NYLOC NUT BZP		16
11	M20x60 SOCKET HEAD CAP SCREW BZP		16
12	M16x60 SOCKET HEAD CAP SCREW BZP		2
13	M16 NYLOC NUT BZP		2

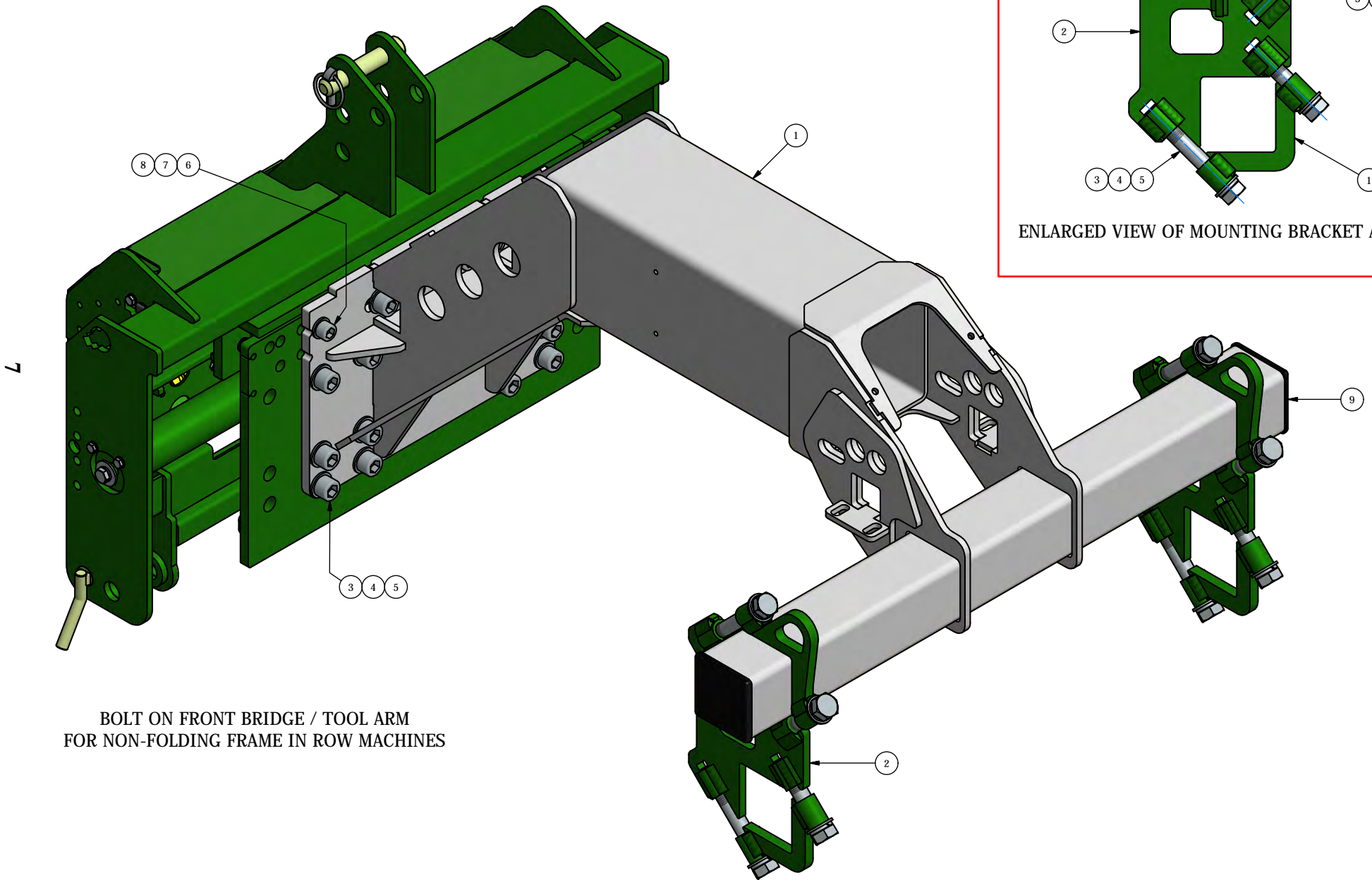

BOLT ON FRONT BRIDGE / TOOL ARM
FOR NON-FOLDING FRAME IN ROW MACHINES

ENLARGED VIEW OF MOUNTING BRACKET ASSEMBLY

ROBOCROP FIXED FRONT BRIDGE / TOOL ARM

ITEM No.	DESCRIPTION	PART No.	QUANTITY
1	FRONT PICK UP BRIDGE / TOOL ARM		
	1100 LONG	10005.01	
	1300 LONG	10163.00	
2	FRONT BRIDGE / PICK UP BRACKETS	10007.00	2
3	M20 WASHER BZP		12
4	M20 NYLOC NUT BZP		12
5	M20x60 SOCKET HEAD CAP SCREW BZP		12
6	M16 WASHER BZP		2
7	M16 NYLOC NUT BZP		2
8	M16x60 SOCKET HEAD CAP SCREW BZP		2
9	END CAP	6455.00	2

MOUNTING BRACKETS

1	FRONT PICK UP CENTRE BRIDGE BRACKET CLAMP	10008.00	1
2	FRONT PICK UP CENTRE BRIDGE BRACKET	10007.04	1
3	M20 WASHER BZP		4
4	M20 SPRING WASHER BZP		4
5	M20x150 BOLT BZP		2
6	M20x110 BOLT BZP		2
7	FRONT PICK UP CENTRE BRIDGE BRACKET CLAMP WITH SLING POINT	10140.00	1

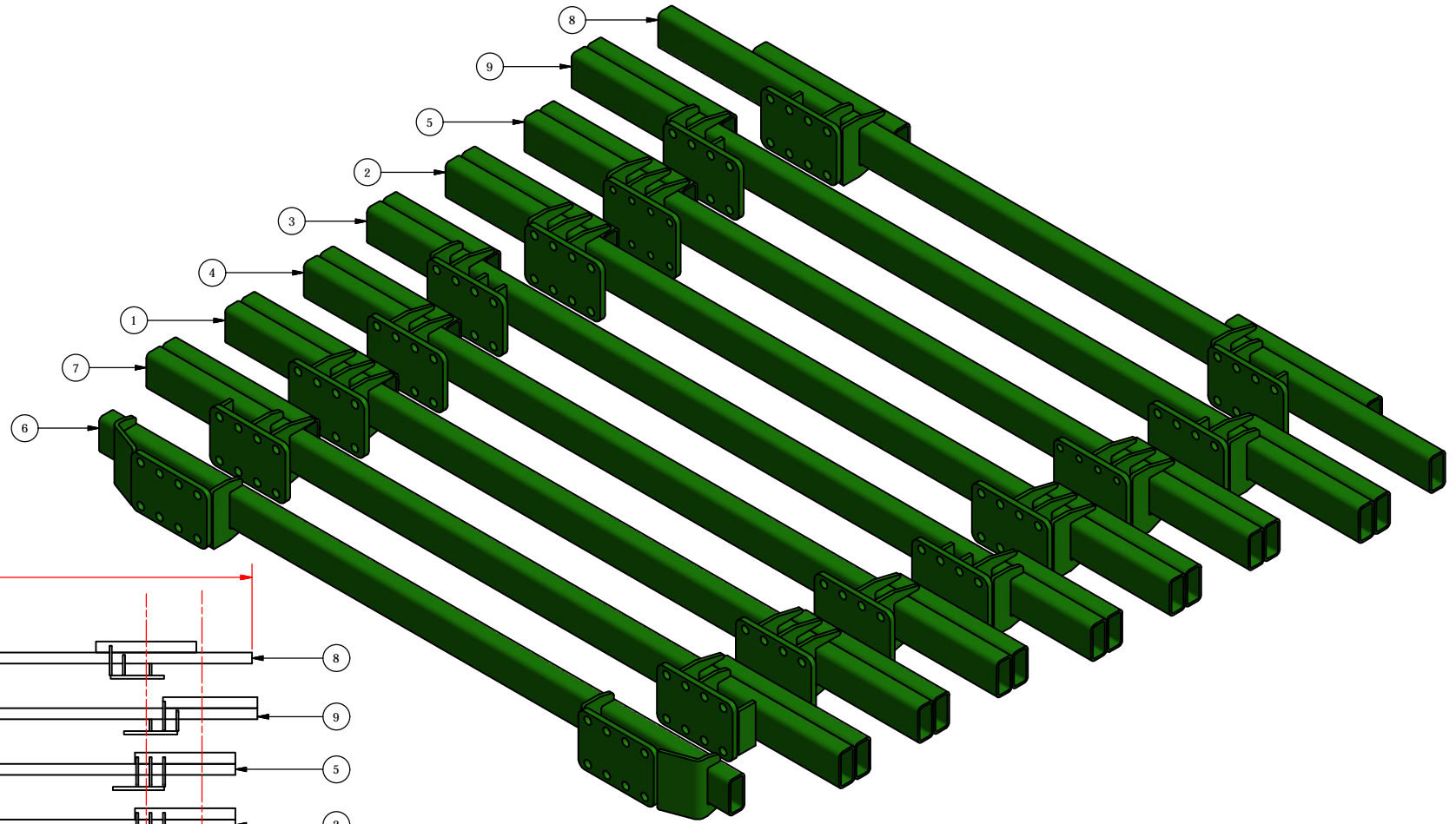

6

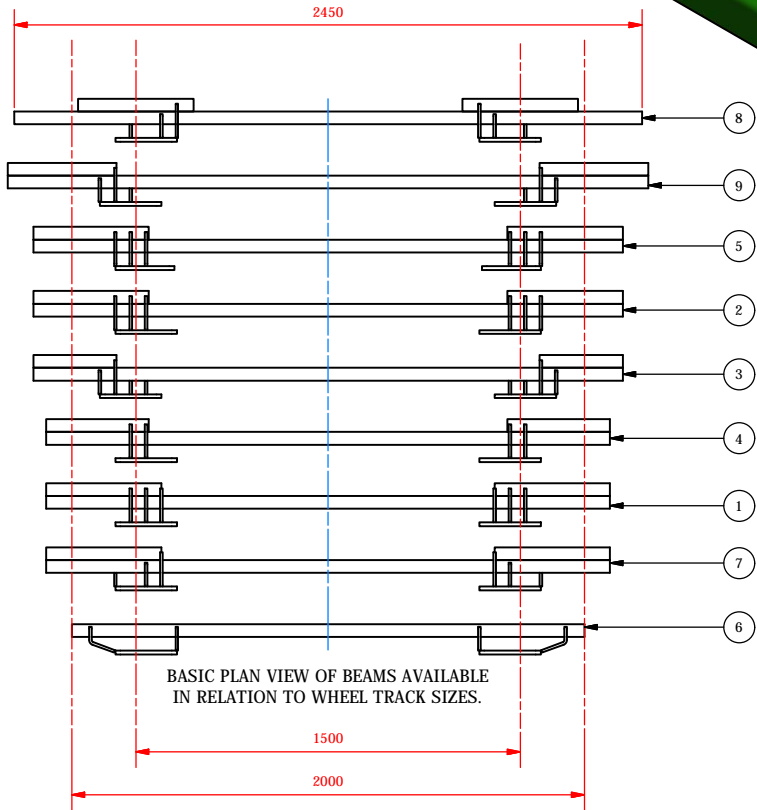

BASIC PLAN VIEW OF BEAMS AVAILABLE
IN RELATION TO WHEEL TRACK SIZES.

DRAWING FOR GUIDENCE, BEAMS ARE SPECIFIC
TO MACHINES. ALWAYS REFUR TO SERIAL NUMBER
FOR IDENTIFICATION PURPOSES.

ROBOCROP DISK STEER FRAME BEAMS

ITEM No.	DESCRIPTION	PART No.	QUANTITY
1	2200 LONG FRAME	9340.00	
2	2300 LONG FRAME	9341.00	
3	2300 LONG FRAME	9346.00	
4	2200 LONG FRAME	9366.00	
5	2300 LONG FRAME	9328.00	
6	2000 LONG FRAME	9542.00	
7	2200 LONG FRAME	9712.00	
8	2450 LONG FRAME	9829.00	
9	2500 LONG FRAME	10348.00	

CONTROL SYSTEM PARTS SECTION

CONTENTS

	PAGE
ROBOCROP ROTOR DRIVE ASSEMBLY	1-2
ROBOCROP CAMERA BRACKET ASSEMBLY	3-4
ROBOCROP CAMERA BRACKET ASSEMBLY – ADDITIONAL ITEMS THT CAMERA – NIGHT OPERATING LIGHTS	5-6
ROBOCROP CONSOLE MOUNT ASSEMBLY	7-8
ROBOCROP STEERING, LEVELLING, CENTRALISING VALVES & GUARDS	9-10
ROBOCROP IN ROW CONTROL SYSTEM	11-18
SCHEMATIC LAYOUT OF CONTROL SYSTEM	11
JUNCTION BOX CONTROL LOOMS	12
RIGHT HAND LEVELLING / STEERING / ROTOR SCHEMATIC	13
LEFT HAND LEVELLING / CENTRALISING / DISK STEER SCHEMATIC	14
LEVELING SYSTEM SCHEMATIC	15
ENCODER WHEEL / SENSORS SCHEMATIC	16
ROTOR BOARD WIRING SCHEMATIC	17
ROBOCROP SIDE SHIFT WING ASSEMBLY	19-20
ROBOCROP IN ROW POWER PACK ASSEMBLY	21-22
ROBOCROP IN ROW POWER PACK HYDRAULIC ITEMS	23-24
ROBOCROP IN ROW REAR COOLER ASSEMBLY	25-26

<CLICK> TO RETURN TO MAIN SUB SECTION CONTENTS PAGE

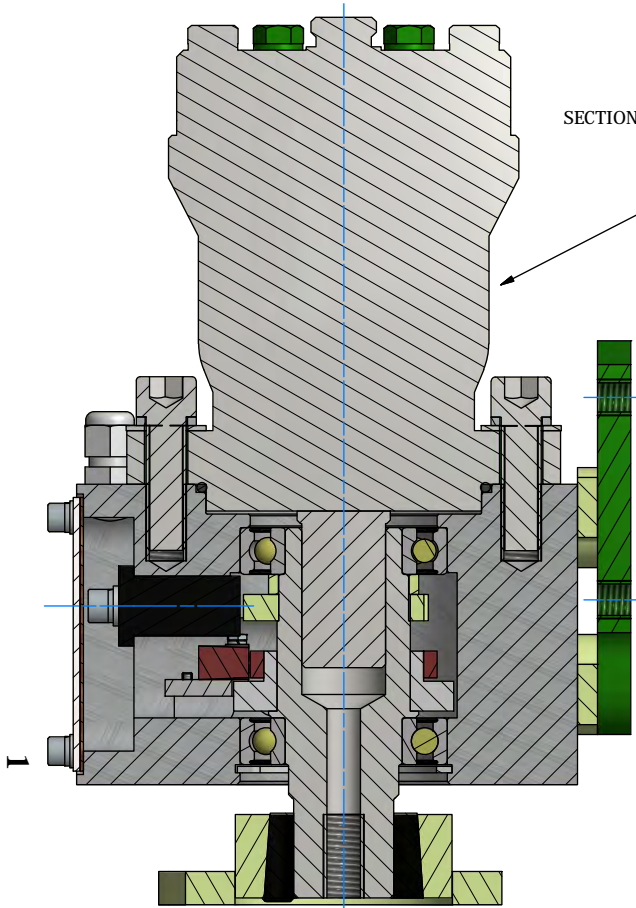

SECTION VIEW SHOWING ASSEMBLY OF ROTOR SHAFT.

ADDITIONAL ITEM :-
9148.00 ROTOR SPACER, TYPICALLY USED FOR FOLDING FRAME MACHINES WHERE ROTOR BLOCK REQUIRES MOVING FORWARD DUE TO MOUNTING BEAMS.

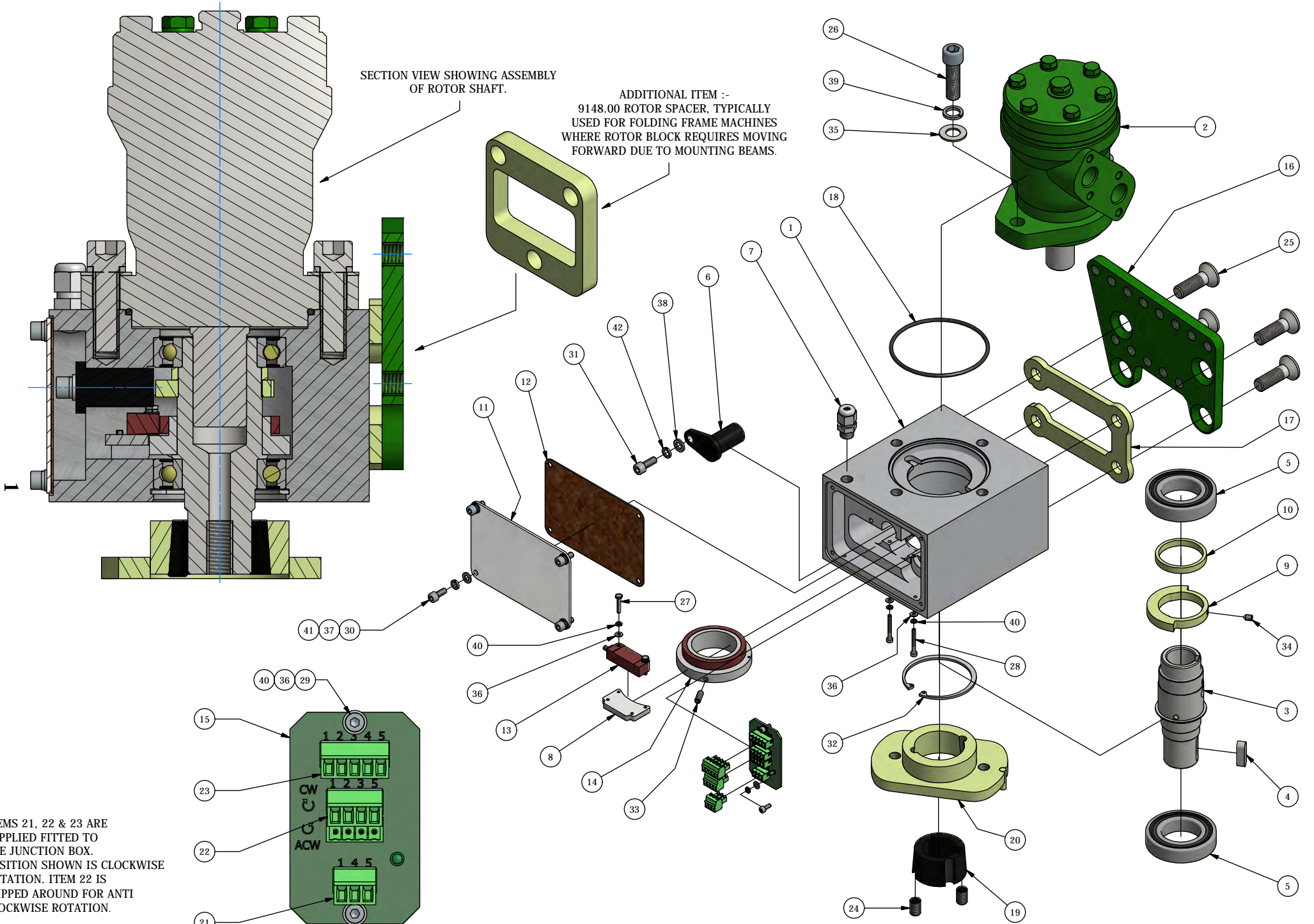
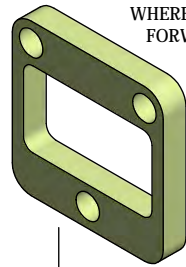

ITEMS 21, 22 & 23 ARE SUPPLIED FITTED TO THE JUNCTION BOX. POSITION SHOWN IS CLOCKWISE ROTATION. ITEM 22 IS FLIPPED AROUND FOR ANTI CLOCKWISE ROTATION.

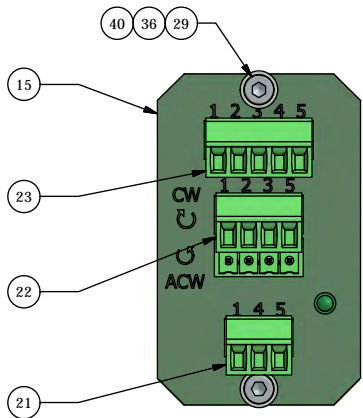

ENLARGED VIEW OF JUNCTION ROTATION BOARD.

ROBOCROP ROTOR DRIVE ASSEMBLY

ITEM No.	DESCRIPTION	PART No.	QUANTITY
1	ROTOR BLOCK	9800.01	1
2	HYDRAULIC MOTOR	8418.00	1
3	ROTOR SHAFT	9801.01	1
4	KEY (8x7x20 LONG)	8821.00	1
5	SEALED BEARING 6007-2RS1		2
6	GEAR TOOTH SENSOR	8311.00	1
7	CABLE GLAND	8631.00	1
8	MAGNET RING SENSOR MOUNT	9802.00	1
9	GEAR TOOTH	9803.00	1
10	ASSEMBLY SPACER	9804.00	1
11	ROTOR BLOCK COVER	9805.00	1
12	CORK SEAL	9806.00	1
13	MAGNET RING SENSOR	9807.00	1
14	MAGNET RING	9808.00	1
15	CAN ROTOR JUNCTION BOARD	9809.00	1
16	ROTOR MOUNTING PLATE	9810.00	1
17	SPACER	9811.00	1
18	O-RING	9812.00	1
19	TAPER LOCK BUSH	5337.00	1
20	ROTOR DRIVE COUPLING	8494.00	1
21	3 PIN PLUG (FITTED TO BOARD)		1
22	4 PIN PLUG (FITTED TO BOARD)		1
23	5 PIN PLUG (FITTED TO BOARD)		1
24	SOCKET SET SCREW, OVAL POINT 3/8"-16 x 5/8" (SUPPLIED WITH TAPER LOCK BUSH)		2
25	C'SUNK ALLEN HEAD SCREW M12x40 BZP		4
26	M12x40 SOCKET CAP SCREW BZP		2
27	M3x16 BOLT BZP		2
28	M3x25 SOCKET CAP SCREW BZP		2
29	M3x8 SOCKET CAP SCREW BZP		2
30	M5x12 SOCKET CAP SCREW BZP		4
31	M6x16 SOCKET CP SCREW BZP		1
32	62MM INTERNAL CIRCLIP		1
33	M5x16 SOCKET SET SCREW BZP		1
34	M5x8 SOCKET SET SCREW BZP		1
35	M12 THIN WASHER BZP		2
36	M3 FLAT WASHER BZP		6
37	M5 FLAT WASHER BZP		4
38	M6 FLAT WASHER BZP		1
39	M12 SPRING WASHER BZP		2
40	M3 SPRING WASHER BZP		6
41	M5 SPRING WASHER BZP		4
42	M6 SPRING WASHER BZP		1

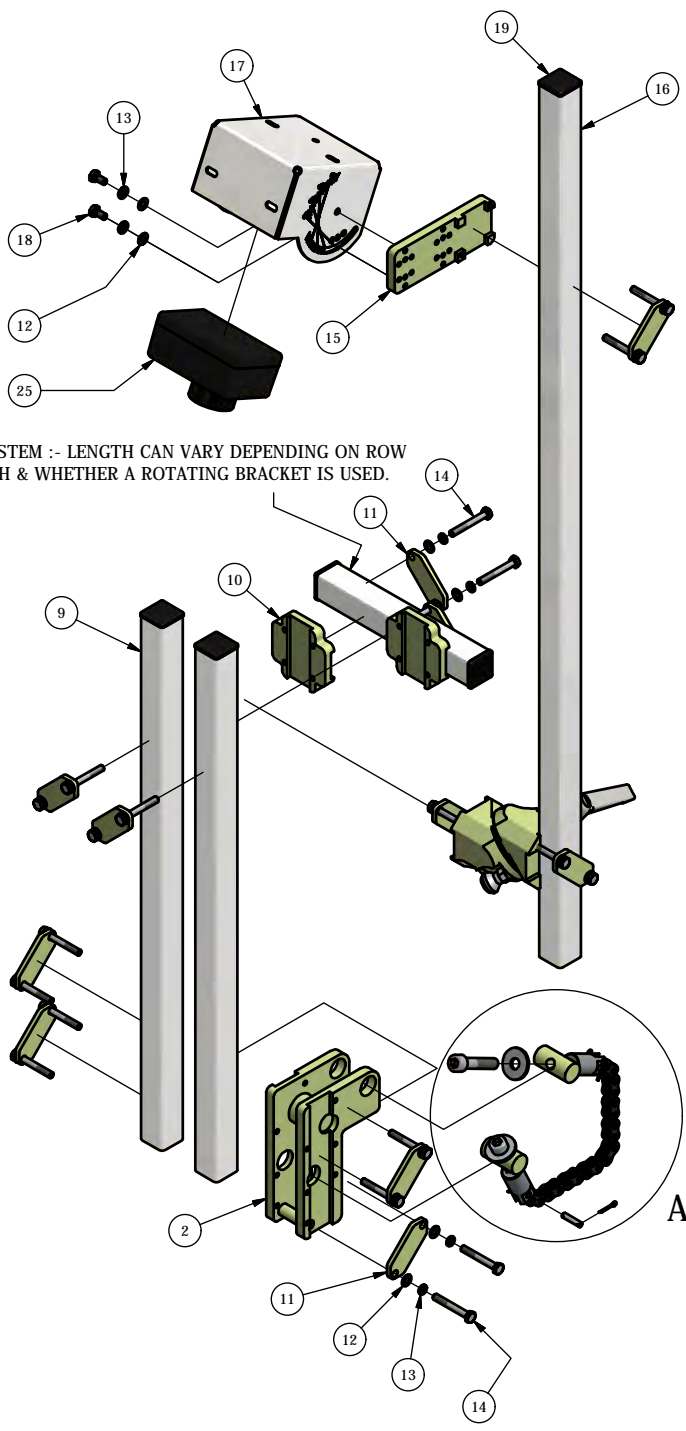

CROSS STEM :- LENGTH CAN VARY DEPENDING ON ROW WIDTH & WHETHER A ROTATING BRACKET IS USED.

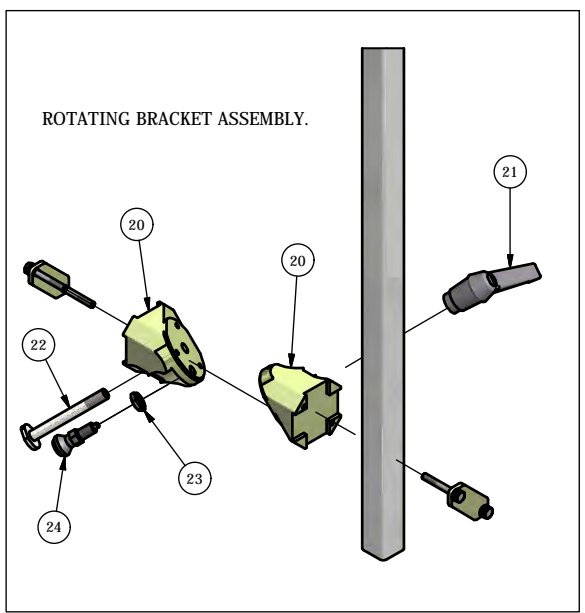

ROTATING BRACKET ASSEMBLY.

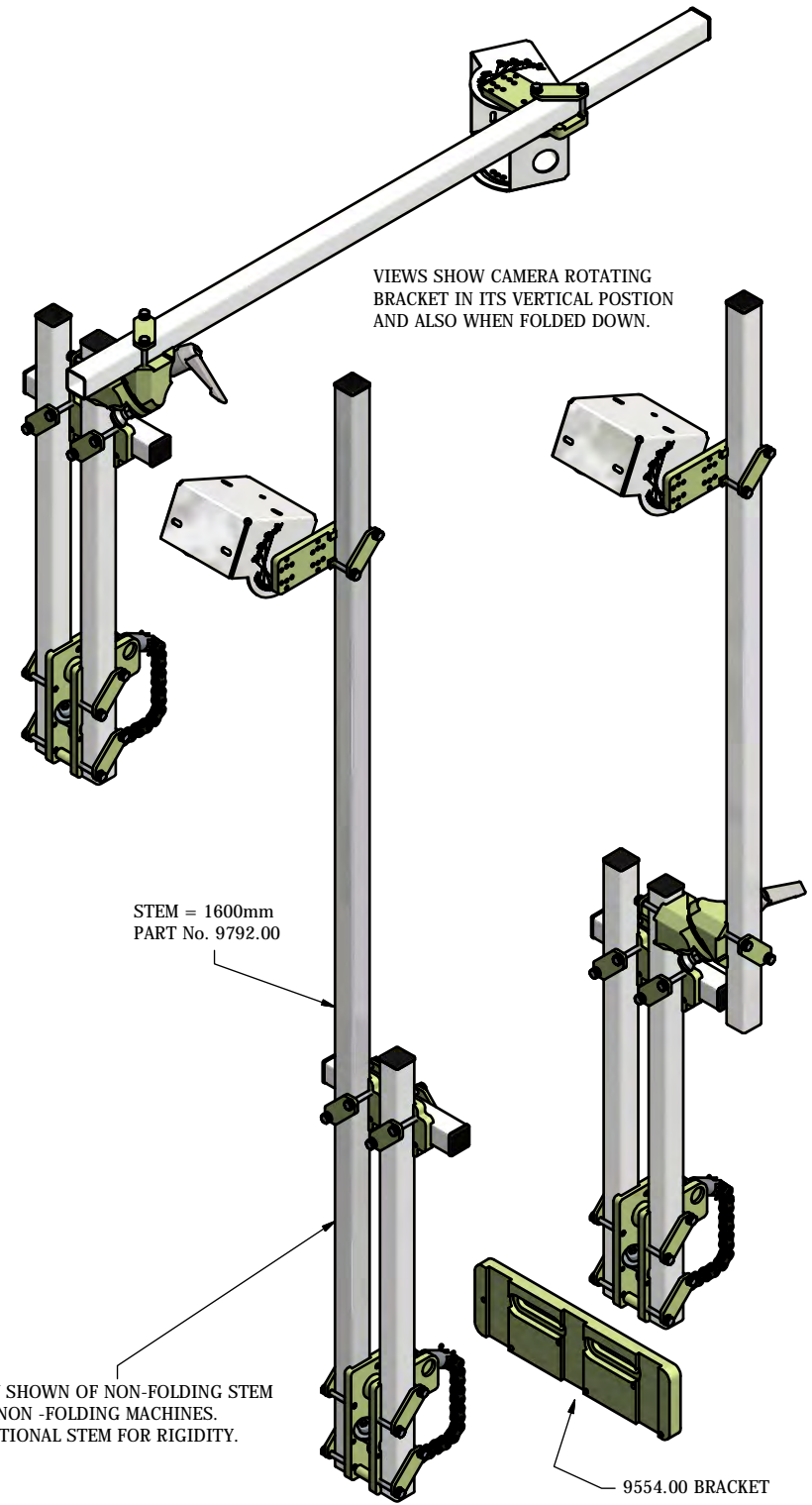

VIEWS SHOW CAMERA ROTATING BRACKET IN ITS VERTICAL POSITION AND ALSO WHEN FOLDED DOWN.

STEM = 1600mm
PART No. 9792.00

VIEW SHOWN OF NON-FOLDING STEM FOR NON-FOLDING MACHINES. ADDITIONAL STEM FOR RIGIDITY.

9554.00 BRACKET

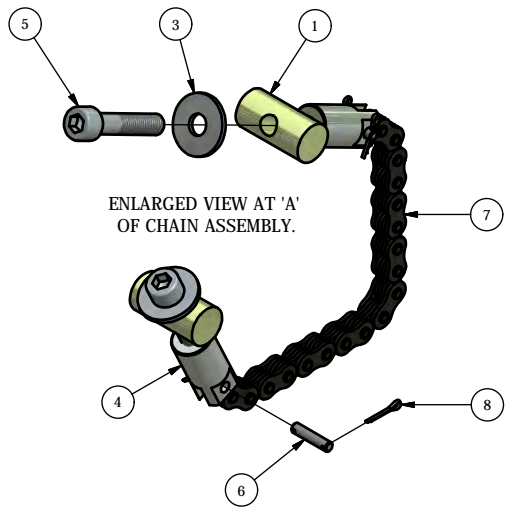

ENLARGED VIEW AT 'A' OF CHAIN ASSEMBLY.

ROBOCROP CAMERA BRACKET ASSEMBLY

ITEM No.	DESCRIPTION	PART No.	QUANTITY
1	CHAIN BOLT PIVOT	9351.00	1
2	CLAMP BRACKET	9400.00	1
3	LARGE DIA WASHER, 10x30x2.5 BZP		2
4	CHAIN ANCHOR	9435.01	2
5	SOCKET CAP SCREW, M10x50 BZP		2
6	CHAIN PIN	9437.00	2
7	CHAIN (AVAILABLE IN VARIOUS LENGTHS)	9436.00	1
8	SPLIT PIN		4
9	CAMERA HIGHT STEM 600mm	9404.00	1
10	CAMERA FRAME BRACKET	9401.00	2
11	CAMERA FRAME CLAMP	9402.00	11
12	M6 FLAT THIN WASHER BZP	5978	24
13	M6 SPRING WASHER BZP	5979	24
14	M6x45 BOLT BZP	5664	22
15	CAMERA FRAME BRACKET	10011.00	1
16	CAMERA HIGHT STEM 1000mm	9434.00	1
17	CAMERA BOX	8570.03	1
18	BOLT M6x12 BZP		2
19	END CAP	8839	5
20	ROTATING CAMERA BRACKET	9355.04	2
21	HANDLE	9438.00	1
22	ROTATING BRACKET PIN	9419.00	1
23	M10 HALF NUT BZP		1
24	LOCKING PIN	9439.00	1
25	ROBO VIS SYS CAMERA, NARROW ANGLE (FIREWIRE)	8983.00	1

**QUANTITY SHOWN IS PER CAMERA BRACKET ASSEMBLY.
TOTAL QUANTITY IS DEPENDENT ON MACHINE
SPECIFICATION.**

ADDITIONAL CAMERA ITEMS.

FOR THT CAMERA.

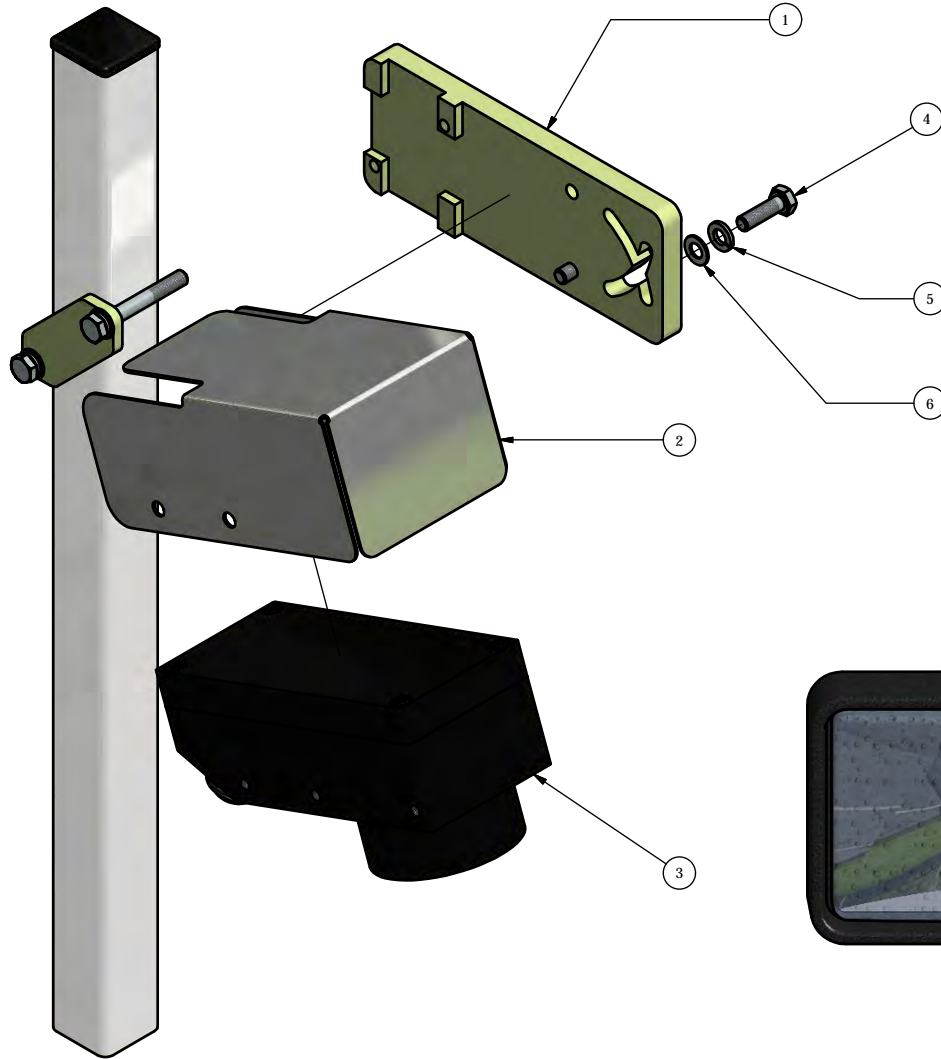

NIGHT OPERATING LIGHTS.

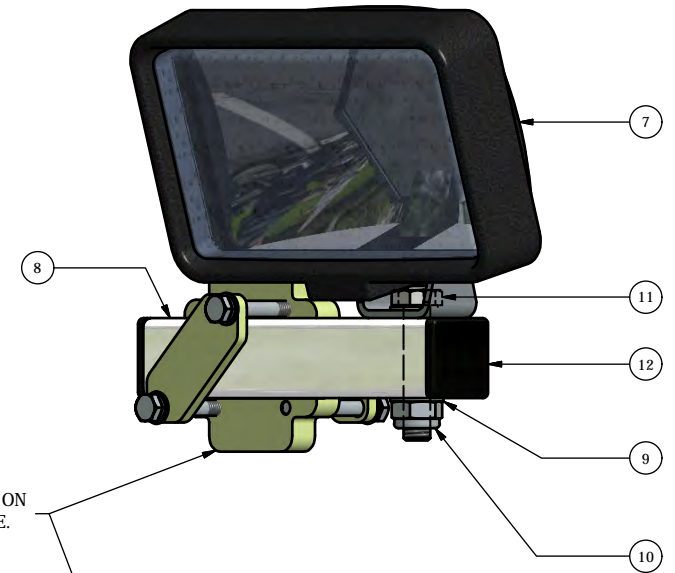

BRACKET PARTS SHOWN ON
CAMERA BRACKET PAGE.

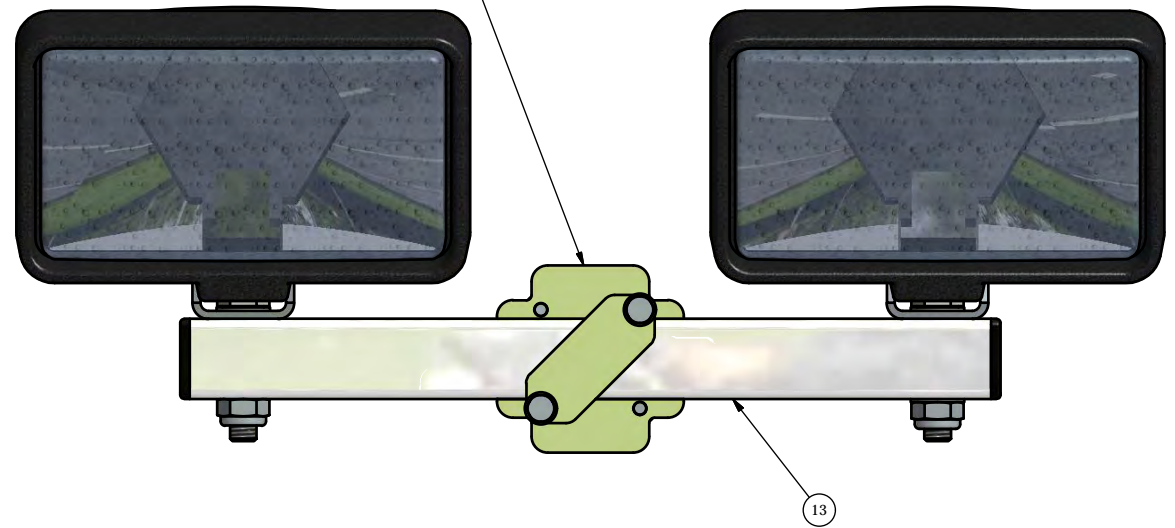

ROBOCROP CAMERA BRACKET ASSEMBLY – ADDITIONAL ITEMS
THT CAMERA – NIGHT OPERATING LIGHTS

ITEM No.	DESCRIPTION	PART No.	QUANTITY
1	CAMERA FRAME BRACKET	10349.00	1
2	CAMERA SHADE	10350.00	1
3	ROBO VIS SYS CAMERA - THT	10160.00	1
4	M6x20 BOLT BZP		2
5	M6 SPRING WASHER BZP	5979	2
6	M6 FLAT THIN WASHER BZP	5978	2
7	LIGHT	10708.00	1
	TWO USED IF USING ITEM 13		
8	MAST	10709.00	1
9	M10 THIN WASHER BZP		2
10	M10 NYLOC NUT BZP		1
11	M10x50 BOLT BZP		1
12	END CAP	8839.00	2
13	MAST	10710.00	1

**QUANTITY SHOWN IS PER CAMERA BRACKET ASSEMBLY.
TOTAL QUANTITY IS DEPENDENT ON MACHINE
SPECIFICATION.**

7

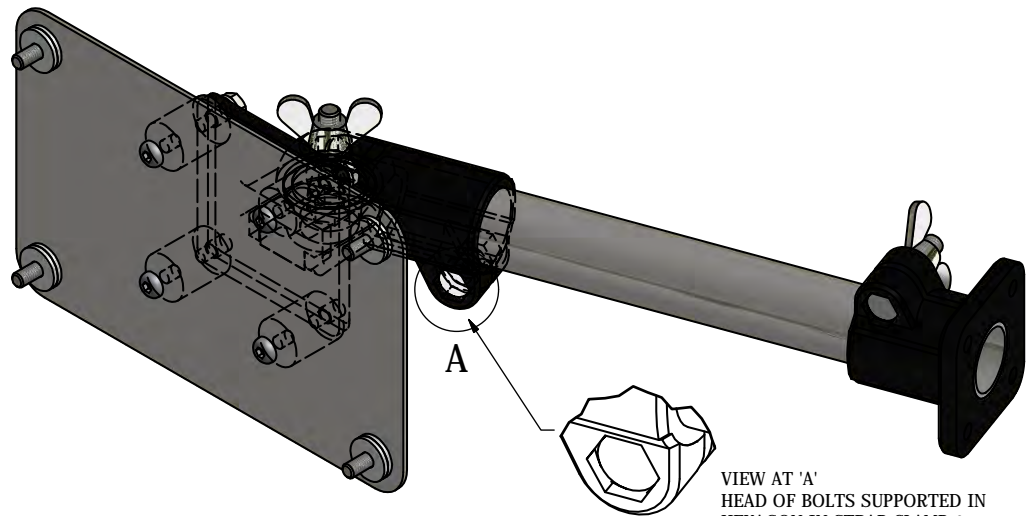
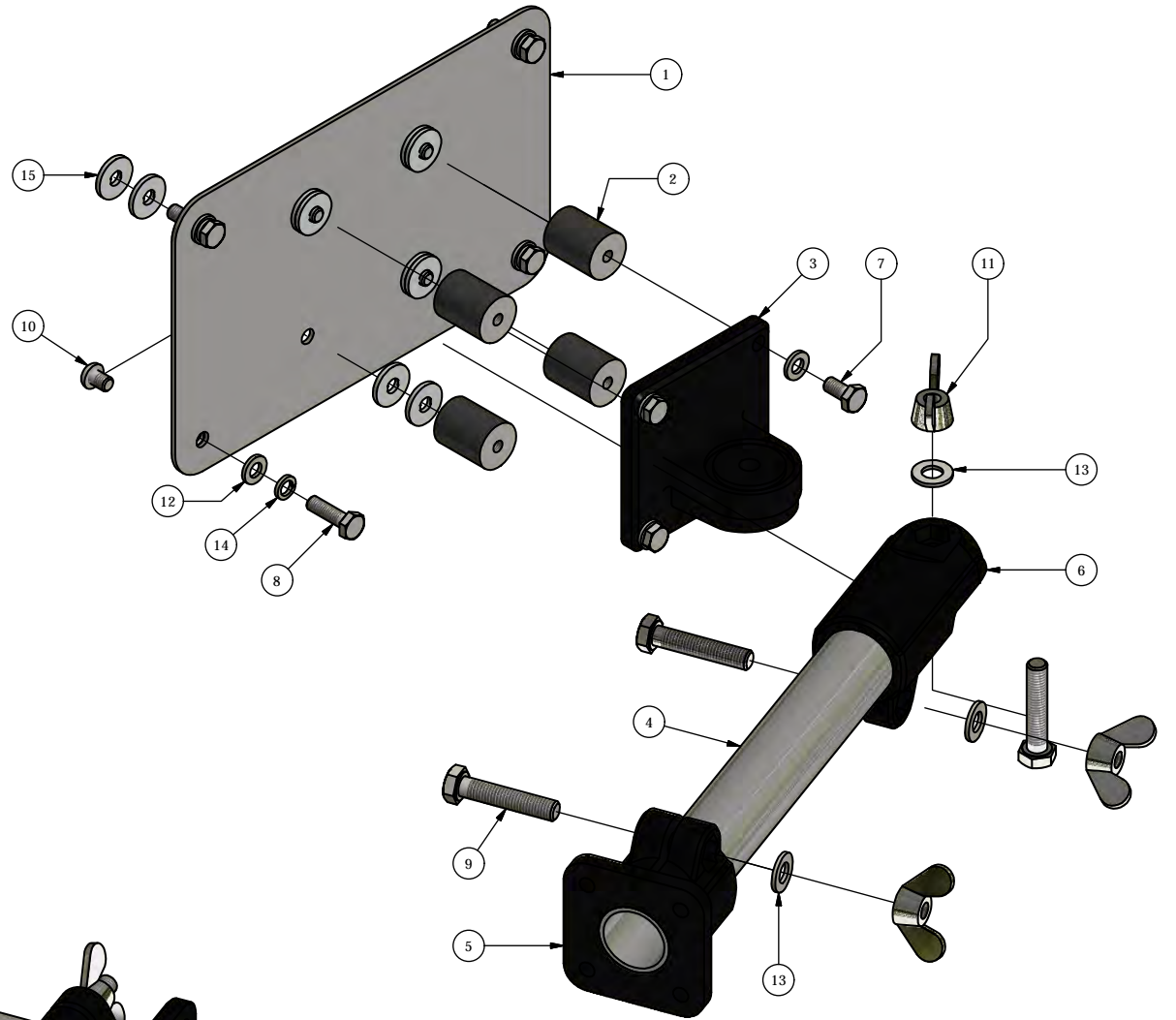
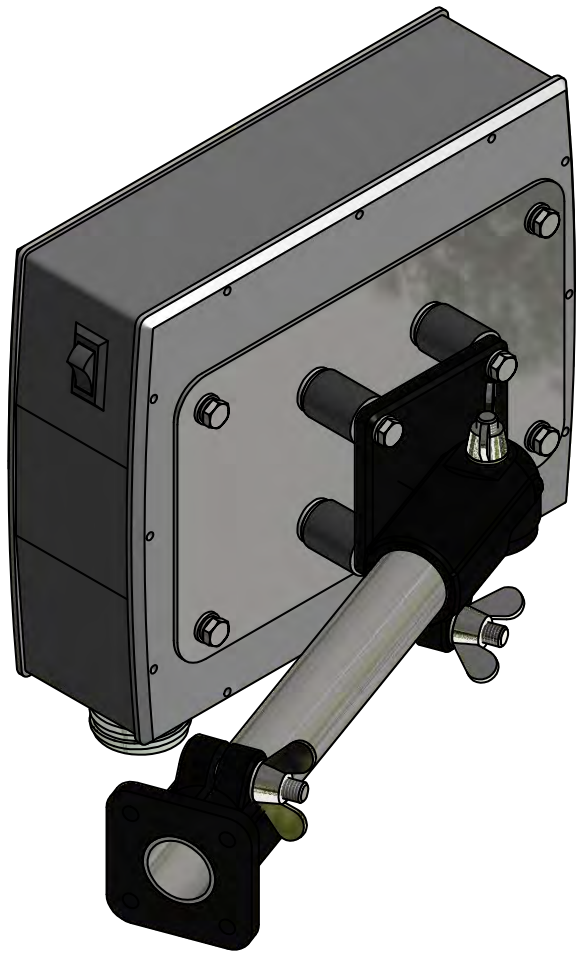

VIEW AT 'A'
HEAD OF BOLTS SUPPORTED IN
HEXAGON IN STRAP CLAMP &
BASE CLAMPS.

ROBOCROP CONSOLE MOUNT ASSEMBLY

ITEM No.	DESCRIPTION	PART No.	QUANTITY
1	CONSOLE MOUNTING PLATE	10571.00	1
2	ANTI-VIBRATION BUFFER	10572.00	4
3	STRAP CLAMP	10573.00	1
4	STAINLESS TUBE	10576.00	1
5	BASE CLAMP	10577.00	1
6	STRAP CLAMP	10607.00	1
7	M6x12 BOLT BZP		4
8	M6x16 BOLT BZP		4
9	M8x40 BOLT BZP		3
10	M6x8 BUTTON HEAD SCREW BZP		4
11	M8 WING NUT BZP		3
12	M6 FLAT WASHER BZP		8
13	M8 FLAT WASHER BZP		3
14	M6 SPRING WASHER BZP		4
15	ANTI - LOSS WASHER	10580.00	16

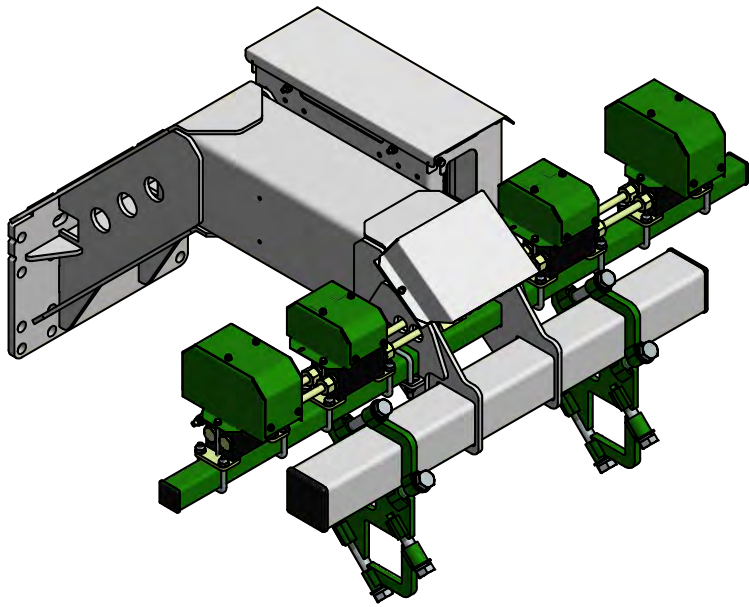

ENLARGED VIEW AT 'A'
DETAIL ON BOLTS FOR ALL GUARDS,
BOLT HEAD INSIDE GUARD.

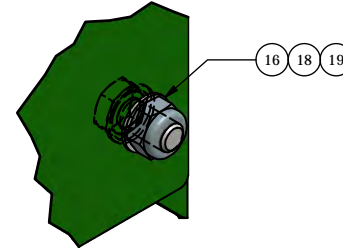

ITEM 11
ROTOR VALVE GUARDS :-
9467.00 GUARD AS 2
9467.00 GUARD AS 3
9467.00 GUARD AS 4
9467.00 GUARD AS 5
9467.00 GUARD AS 6

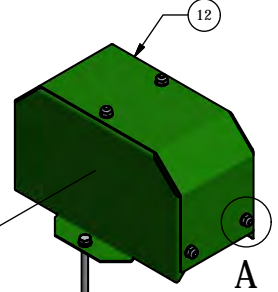

6

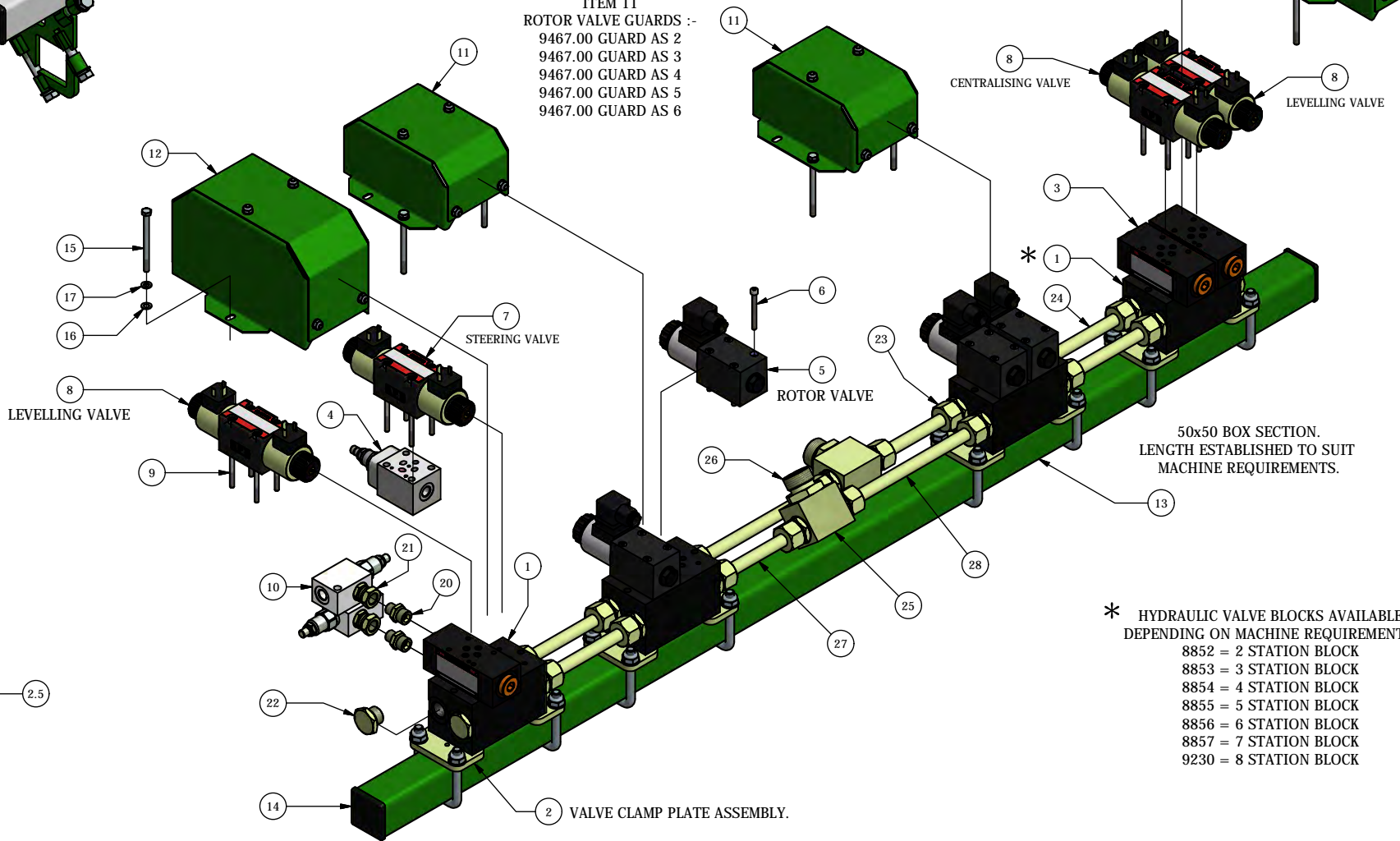

ITEM 2
VALVE CLAMP PLATE ASSEMBLY.

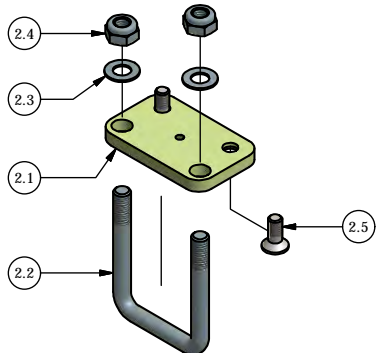

* HYDRAULIC VALVE BLOCKS AVAILABLE
DEPENDING ON MACHINE REQUIREMENTS.
8852 = 2 STATION BLOCK
8853 = 3 STATION BLOCK
8854 = 4 STATION BLOCK
8855 = 5 STATION BLOCK
8856 = 6 STATION BLOCK
8857 = 7 STATION BLOCK
9230 = 8 STATION BLOCK

ROBOCROP STEERING, LEVELLING, CENTRALISING VALVES & GUARDS

ITEM No.	DESCRIPTION	PART No.	QUANTITY
1	HYDRAULIC VALVE BLOCKS (SEE DRAWING) (QUANTITY DEPENDENT ON MACHINE)		
2	CLAMP ASSEMBLY (QUANTITY DEPENDENT ON MACHINE)		
	2.1 CLAMP PLATE	9033.01	
	2.2 U-BOLT, M10 FOR 50x50 BOX, BZP	8672.00	
	2.3 M10 THIN WASHER BZP		
	2.4 M10 NYLOC NUT BZP		
	2.5 M8x20 C'SUNK ALLEN HEAD SCREW BZP		
3	HYDRAULIC CHECK VALVE	8863.00	3
4	PRESSURE REDUCING VALVE	9727.00	1
5	ROTOR VALVE (QUANTITY DEPENDENT ON MACHINE)	8587.00	
6	M5x50 SOCKET CAP SCREW BZP		16
7	HYDRAULIC VALVE	8858.01	1
8	HYDRAULIC VALVE	8860.01	3
9	M5x90 SOCKET HEAD CAP SCREW BZP		16
10	HYDRAULIC FLOW VALVE	8959.00	2
11	VALVE GUARD (SEE DRAWING)		
12	VALVE GUARD	9056.00.guard as 2	2
13	VALVE BEAM, 50x50 BOX (SEE DRAWING)		
14	END CAP	7501.00	2
15	M6x80 BOLT BZP		8
16	M6 THIN WASHER BZP		56
17	M6 SPRING WASHER BZP		8
18	M6x12 BOLT BZP		24
19	M6 NYLOC NUT BZP		24
20	HYDRAULIC ADAPTOR, 3/8 – 1/4 M/M	5619.00	2
21	HYDRAULIC ADAPTOR, 1/4 – 1/4 M/F	7617.00	2
22	HYDRAULIC PLUG	7936.00	4
23	HYDRAULIC ADAPTOR	9343.00	16
24	HYDRAULIC PIPE (CUT TO SIZE)		4
25	HYDRAULIC TEE BLOCK	10352.00	2
26	HYDRAULIC ADAPTOR, 1 – 3/4 M/M	5523.00	2
27	HYDRAULIC PIPE (CUT TO SIZE)		2
28	HYDRAULIC PIPE (CUT TO SIZE)		2

QUANTITIES ABOVE ARE A GUIDE, AS NUMBER OF ROWS, MACHINE SPECIFICATION WILL DICTATE OVERALL QUANTITY REQUIRED.

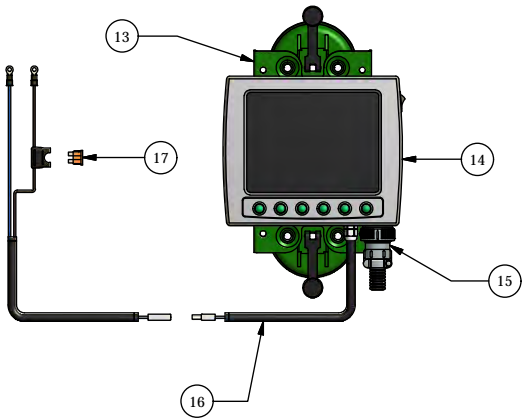
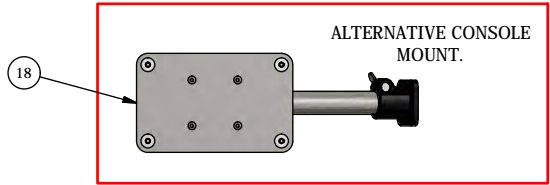

SIDE SHIFT GUARDS SHOWN REMOVED.

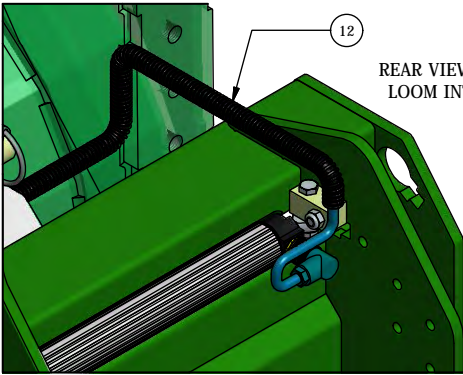
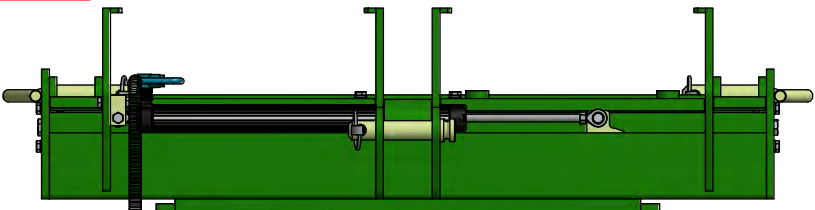

19 CONTROL SYSTEM POWER CABLE.

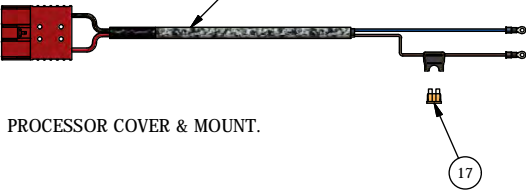

1 3 PROCESSOR COVER & MOUNT.



11

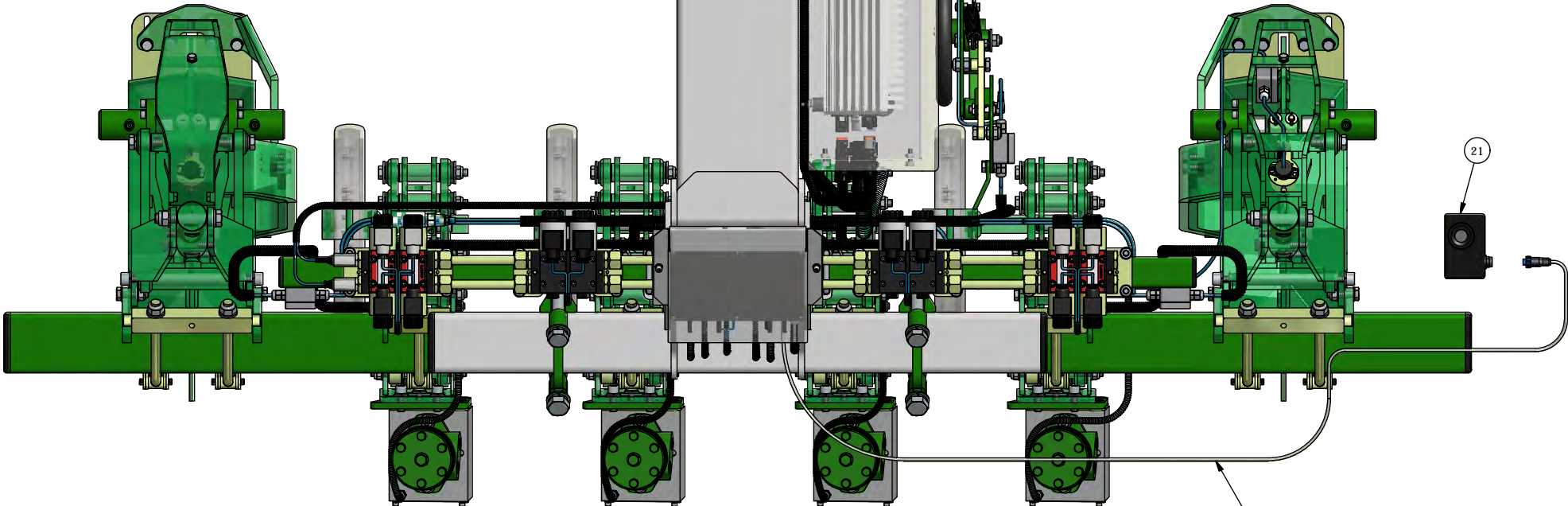

20 CAMERA LOOM.

21



FRONT VIEW OF CAN JUNCTION BOX SYSTEM.

10596.00 - 12 WAY VALVE LOOM.
(TO RIGHT HAND VALVE BLOCKS)

8

7 10595.00 - CAN & POWER 4 WAY LOOM.
WIRED INTO CAN ROTOR JUNCTION BOX.

9 10597.00 - 8 WAY VALVE LOOM.
(TO LEFT HAND VALVE BLOCKS)

22 10594.00 - 31 WAY SENSOR LOOM.

REAR VIEW OF CAN JUNCTION BOX SYSTEM.

CONTROL SYSTEM POWER CABLE. 19

12

10581.00 - CAMERA LOOM. 20

15

9384.00 - CONSOLE TO CAN JUNCTION BOX LOOM.

12

CAN JUNCTION BOX SYSTEM. 2

HOSES / CABLES ARE ROUTED THROUGH THE FRONT BRIDGE (WHITE ARM). THE 31 WAY LOOM ALSO HAS A SPLITTER JUNCTION.

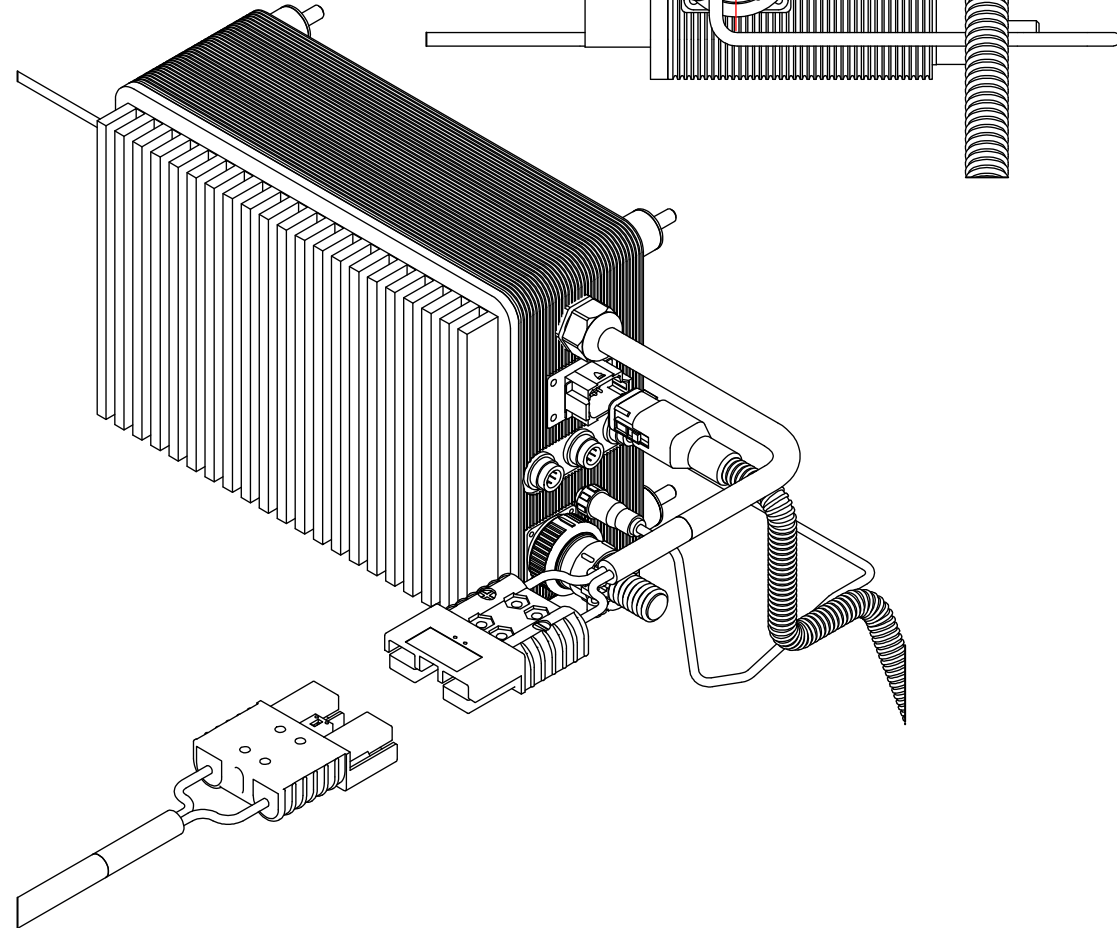

RIGHT HAND SIDE OF MACHINE.
LEVELLING / STEERING VALVES
& ROTOR VALVES.

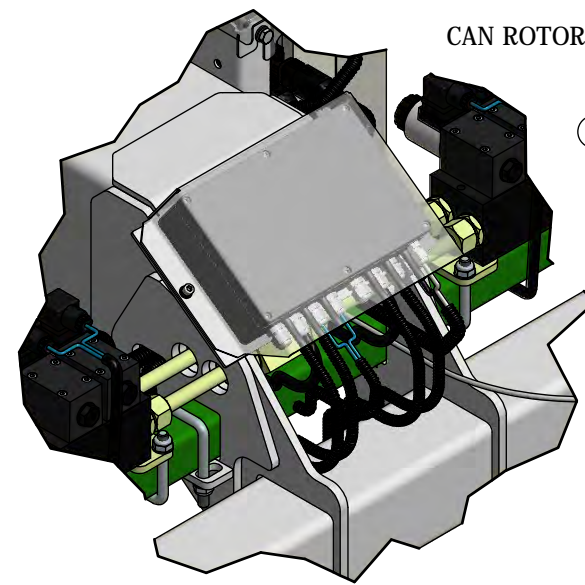
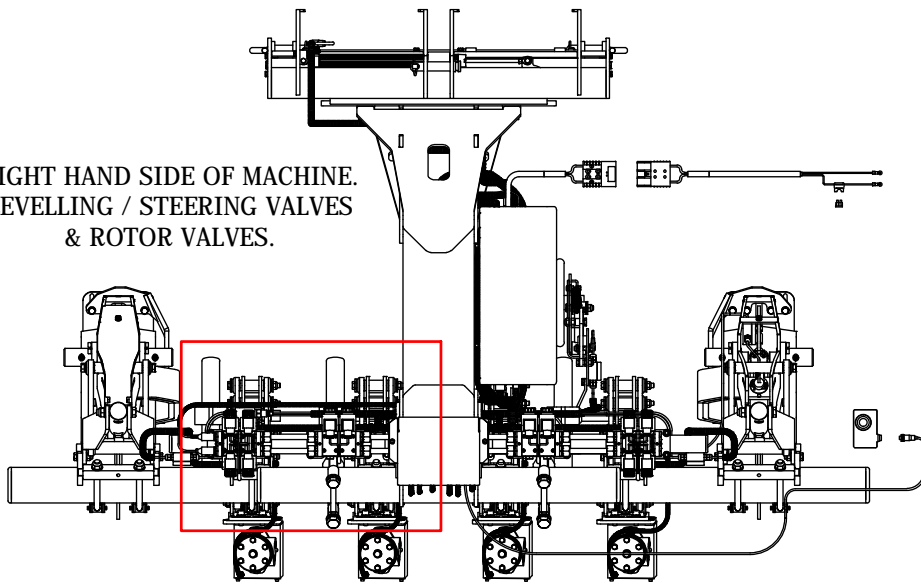

CAN ROTOR JUNCTION BOX.

CABLE GLANDS.

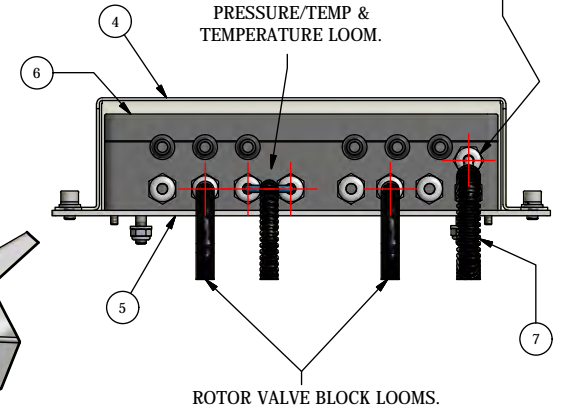

13

WIRING LOOM FOR PRESSURE & TEMP,
& TEMPERATURE SENSORS.
(INTO CAN ROTOR JUNCTION BOX)

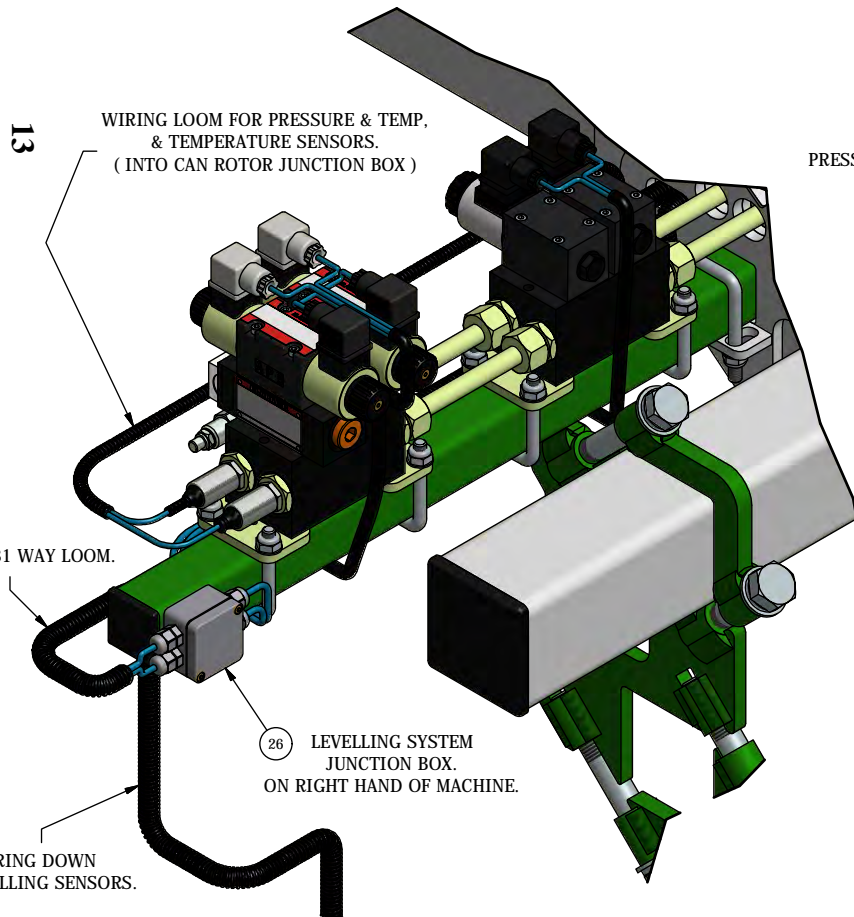

LEVELLING VALVE.

STEERING VALVE. 8

PRESSURE & TEMPERATURE. 28

PRESSURE. 27

WIRING FROM 12 WAY LOOM
INTO LEVELLING / STEERING VALVES. 8

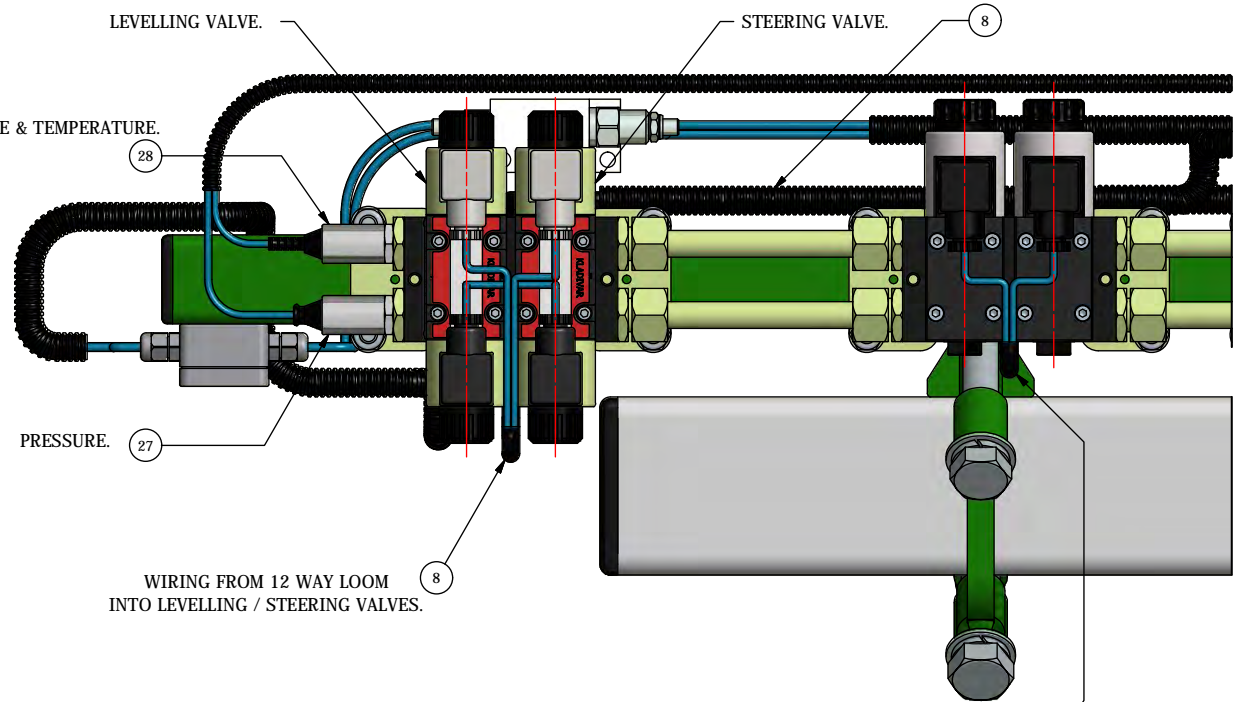

RIGHT HAND ROTOR VALVE BLOCK LOOM
WIRED INTO CAN JUNCTION BOX AS SHOWN ABOVE. 10

10

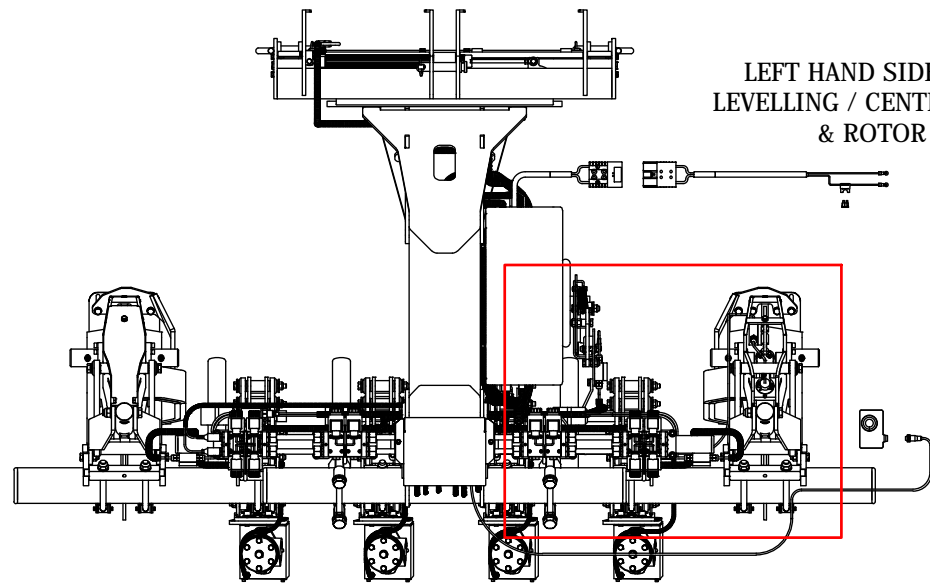

LEFT HAND SIDE OF MACHINE.
LEVELLING / CENTRALISING VALVES
& ROTOR VALVES.

14

31 WAY SENSOR LOOM. (22)
LEVELLING SYSTEM & DISK STEER
LOOMS, WIRED INTO 31 WAY SENSOR LOOM.
(WHICH HAS A SPLITTER JUNCTION INSIDE FRONT BRIDGE.)

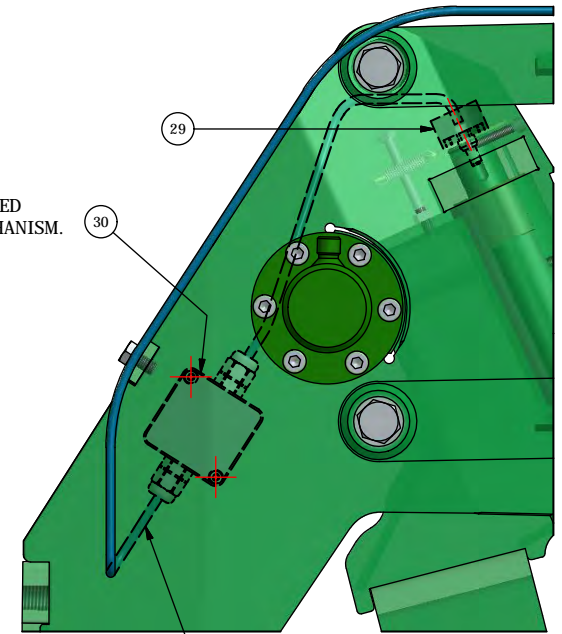

JUNCTION BOX FITTED
INSIDE DISK STEER MECHANISM.

DISK STEER STEERING POTENTIOMETER LOOM.

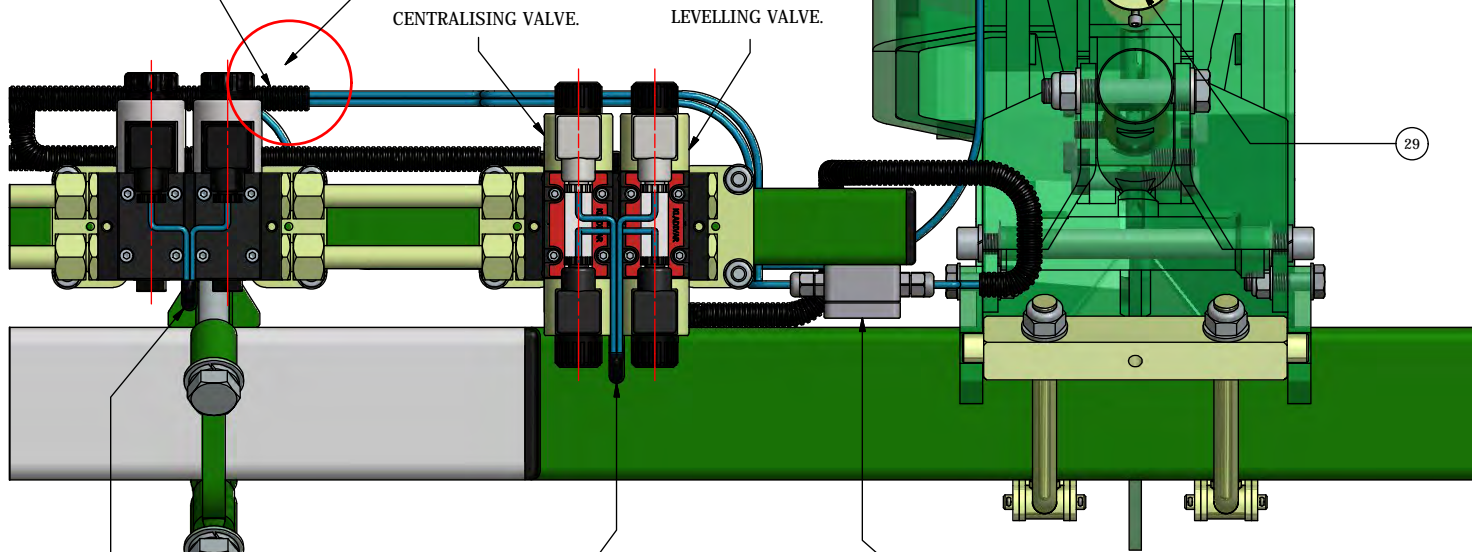

CENTRALISING VALVE. LEVELLING VALVE.

WIRING FROM 8 WAY LOOM INTO
LEVELLING & CENTRALISING VALVES.

LEVELLING SYSTEM
JUNCTION BOX.
ON LEFT HAND OF MACHINE.

LEFT HAND ROTOR VALVE BLOCK LOOM.
WIRED INTO CAN JUNCTION BOX.

LEVELLING SYSTEM.

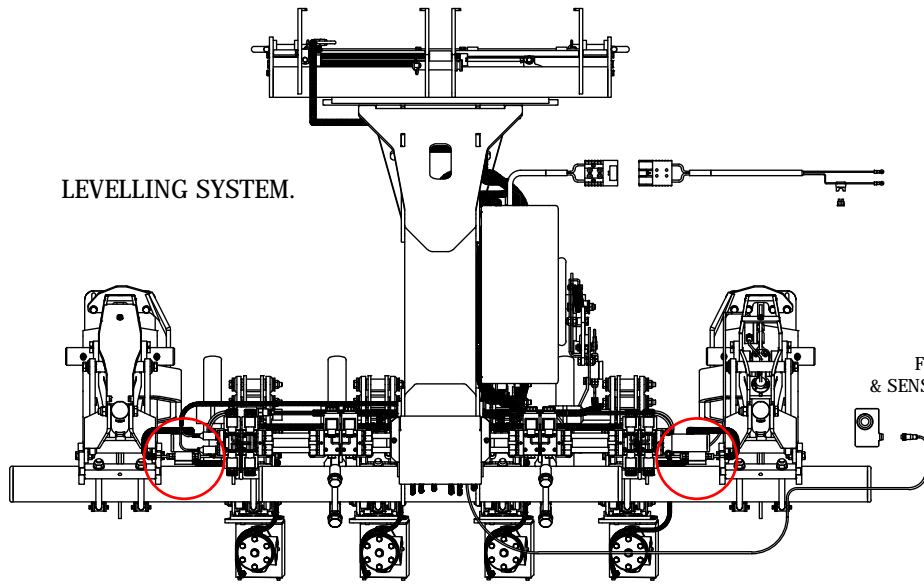

LEVELLING SYSTEM JUNCTION BOXES
FITTED TO EACH SIDE OF VALVE TOOL BAR,
& SENSORS ARE FITTED TO THE OUTER WHEEL UNITS.

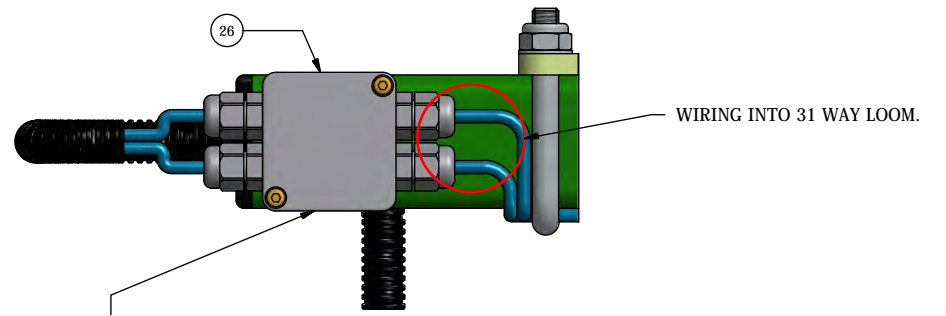

WIRING INTO 31 WAY LOOM.

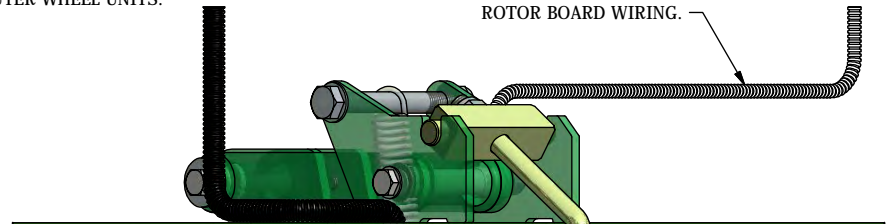

ROTOR BOARD WIRING.

15

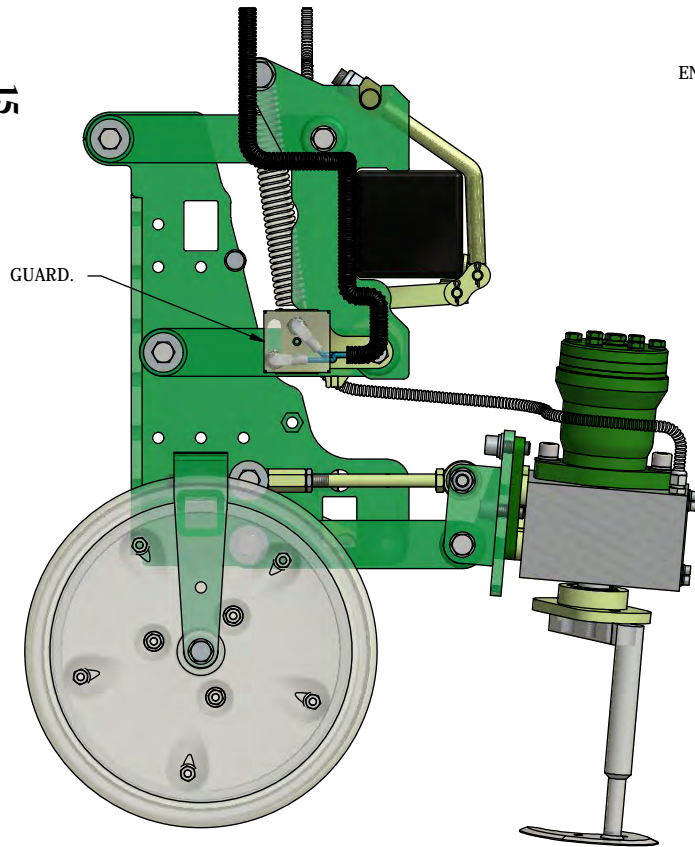

GUARD.

ENLARGED VIEW AT 'A'

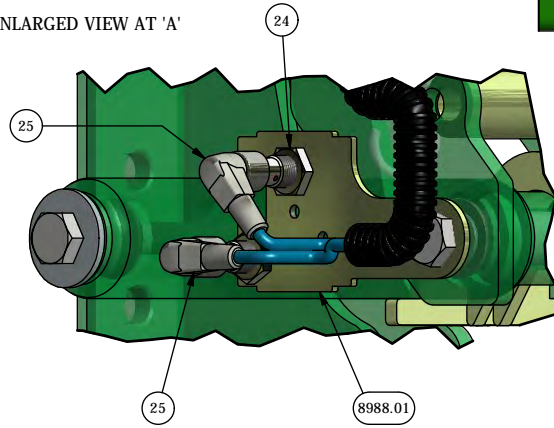

LEVEL SENSOR BRACKET.

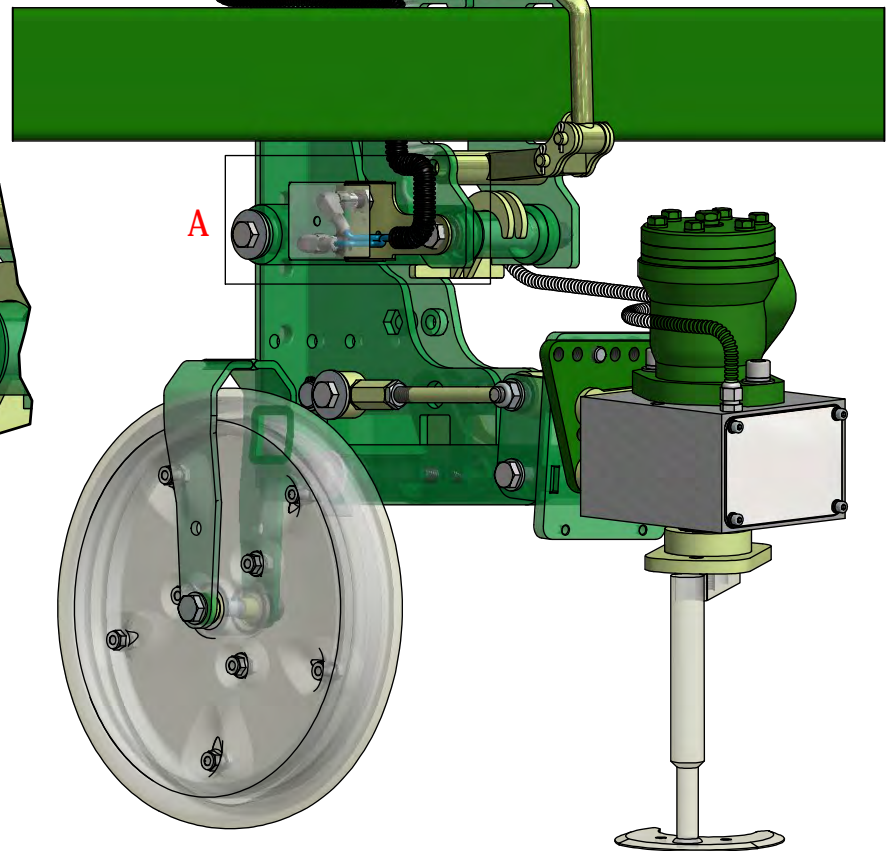

A

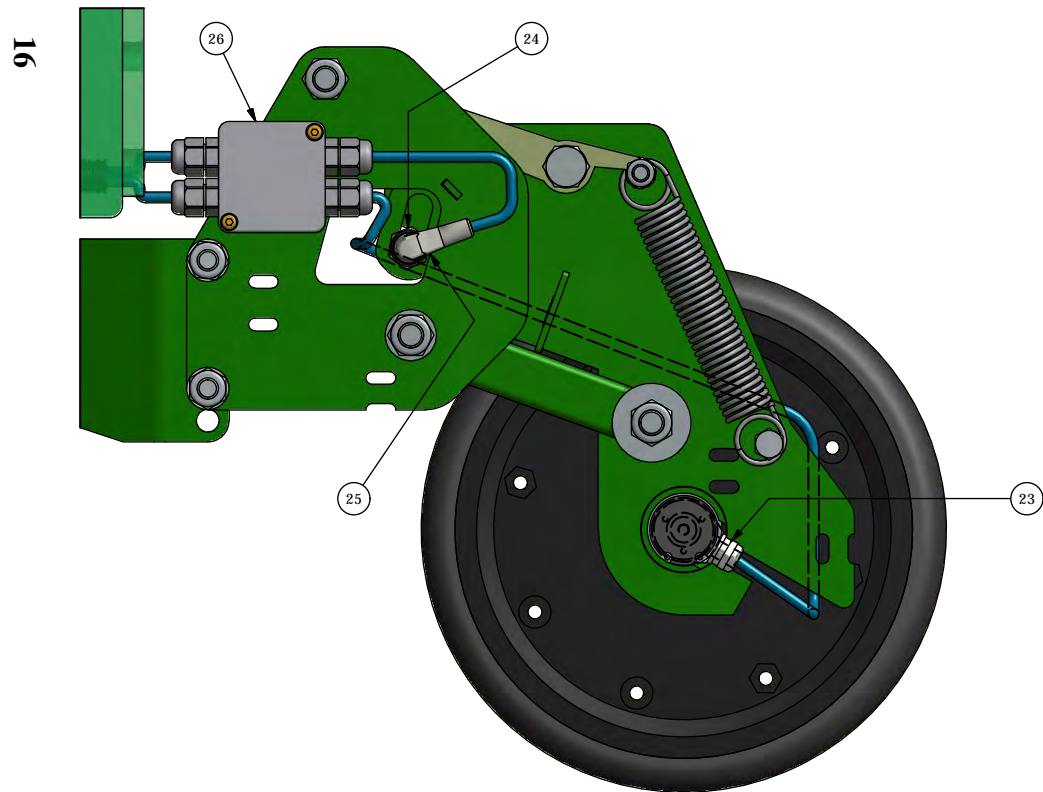
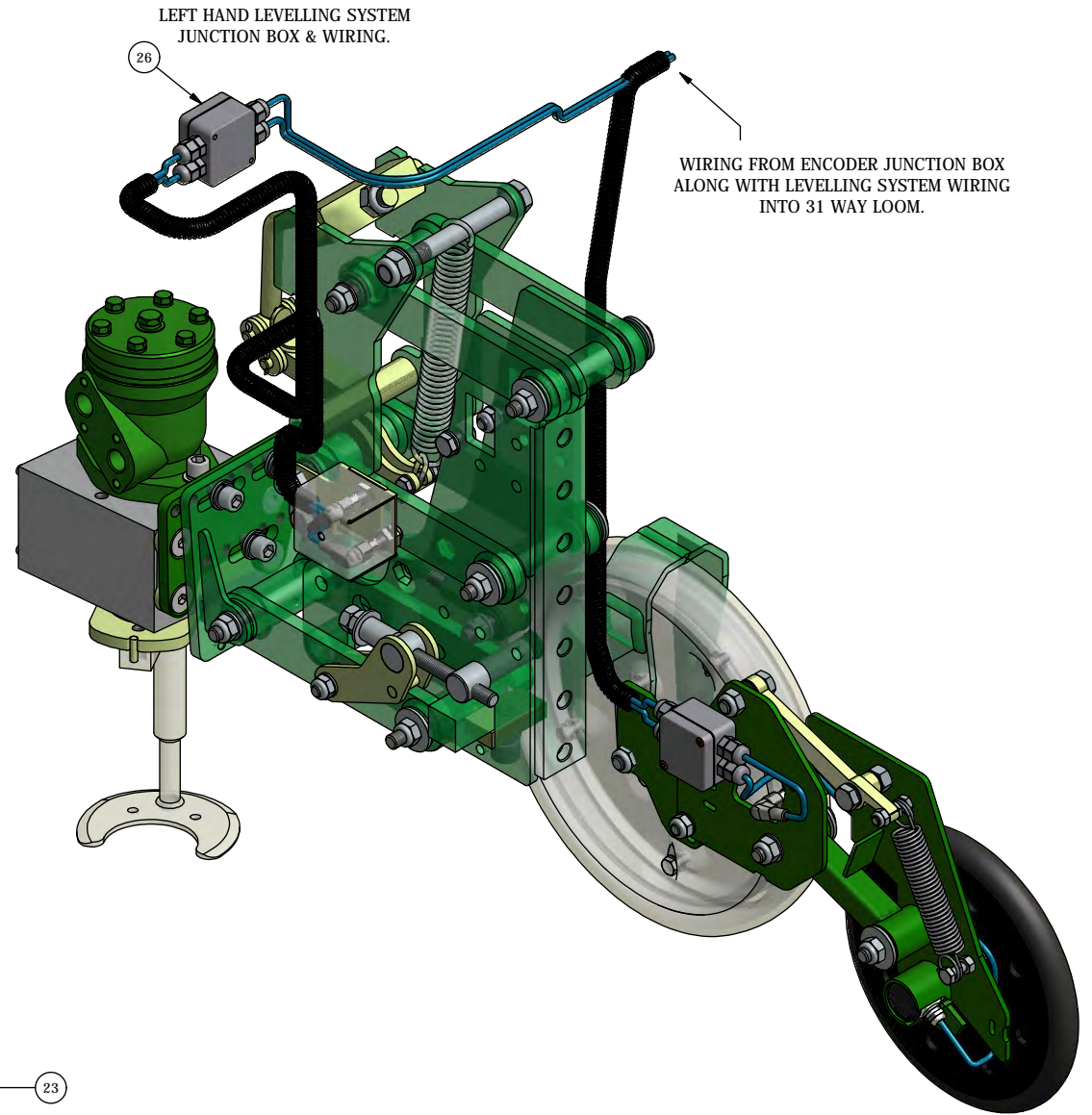
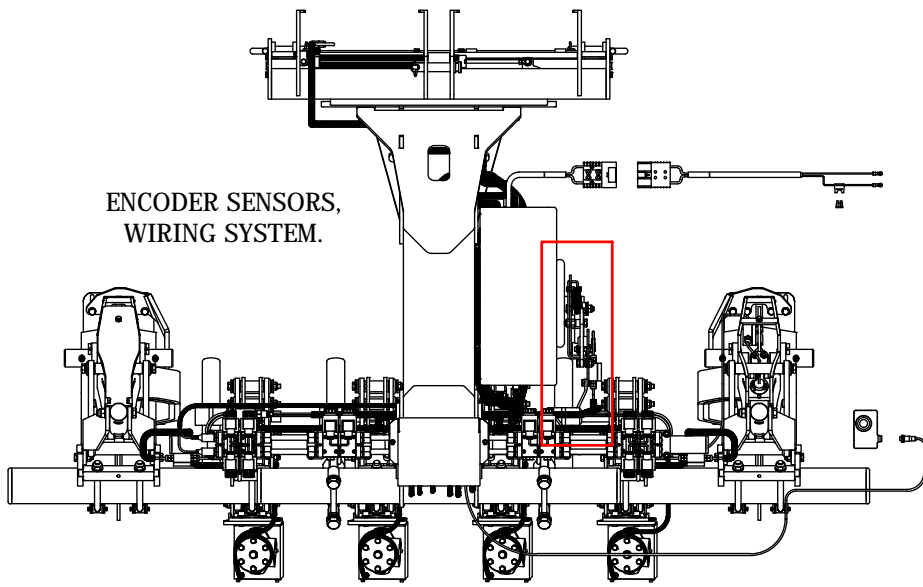

ROTOR BOARD WIRING & LOOM.

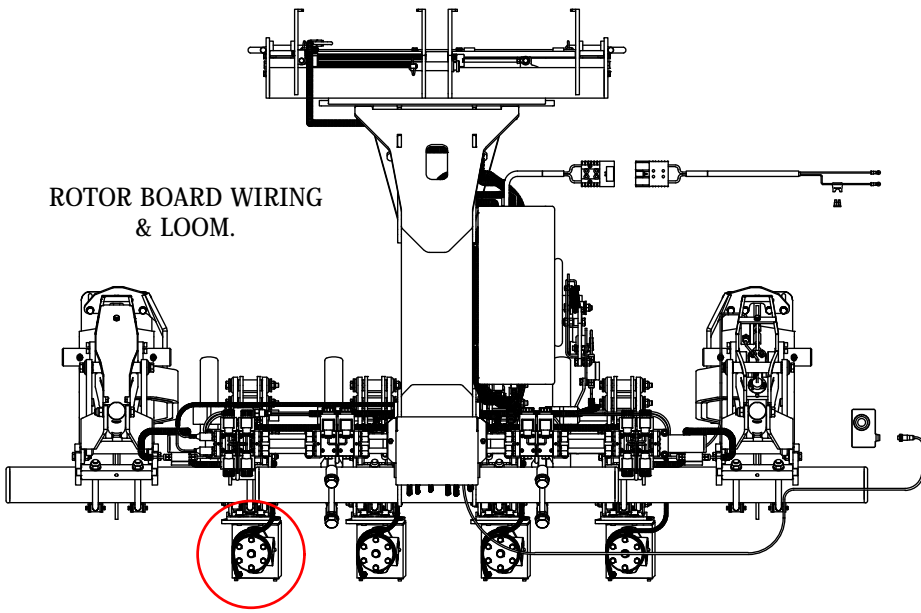

ROTOR BOARD WIRING LOOMS DIRECTLY INTO REMOVABLE GLANDS ON CAN ROTOR BOX.

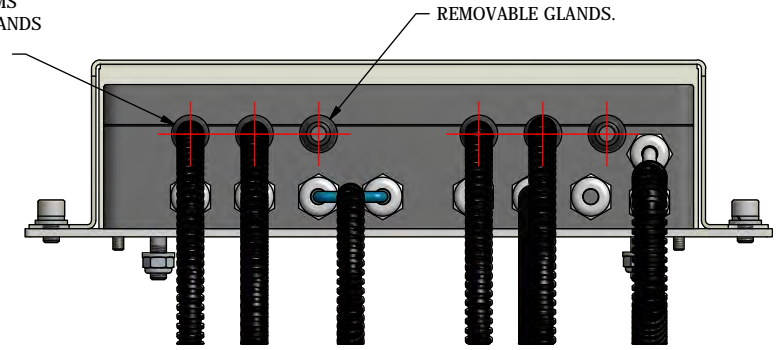

17

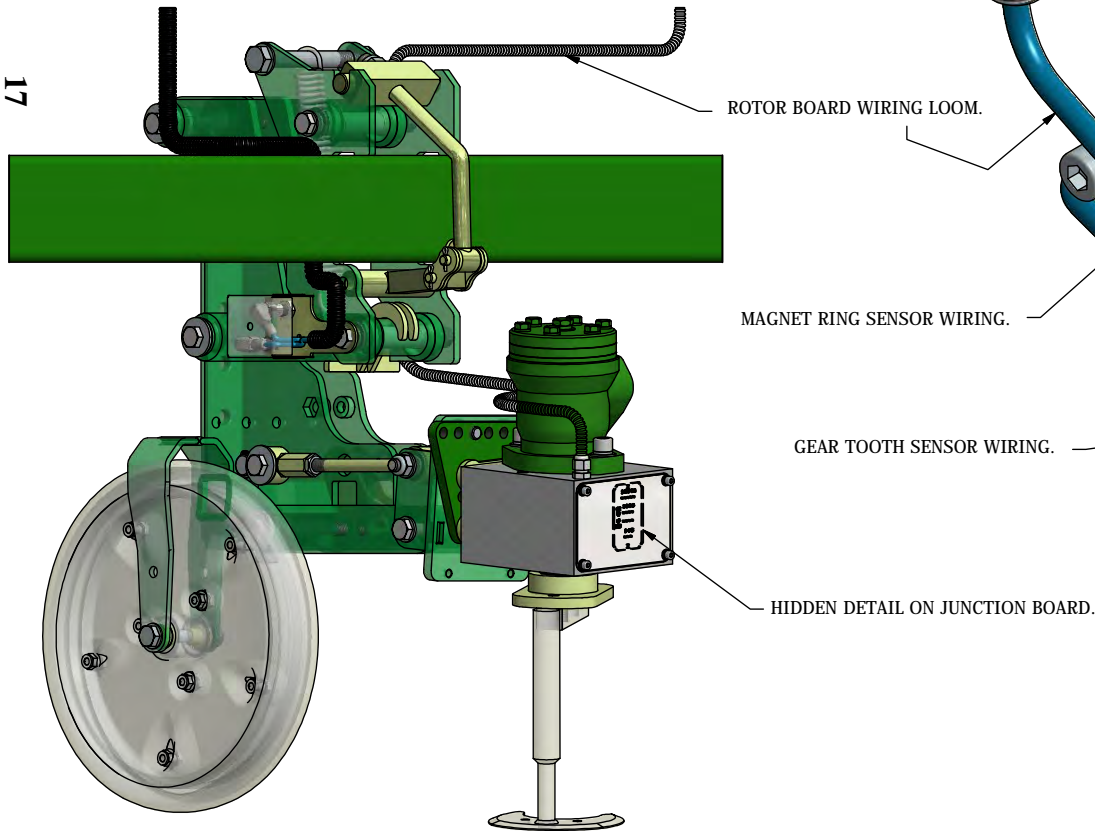

GEAR TOOTH.

ROTOR BOARD WIRING LOOM.

MAGNET RING SENSOR WIRING.

GEAR TOOTH SENSOR WIRING.

HIDDEN DETAIL ON JUNCTION BOARD.

VIEWS OF WIRING INSIDE ROTOR BLOCK. PART NUMBERS ON ITEMS ARE FOUND IN THE ROTOR BLOCK SECTION OF PARTS BOOK.

MAGNET RING.

JUNCTION BOARD.

GEAR TOOTH SENSOR.

MAGNET RING SENSOR.

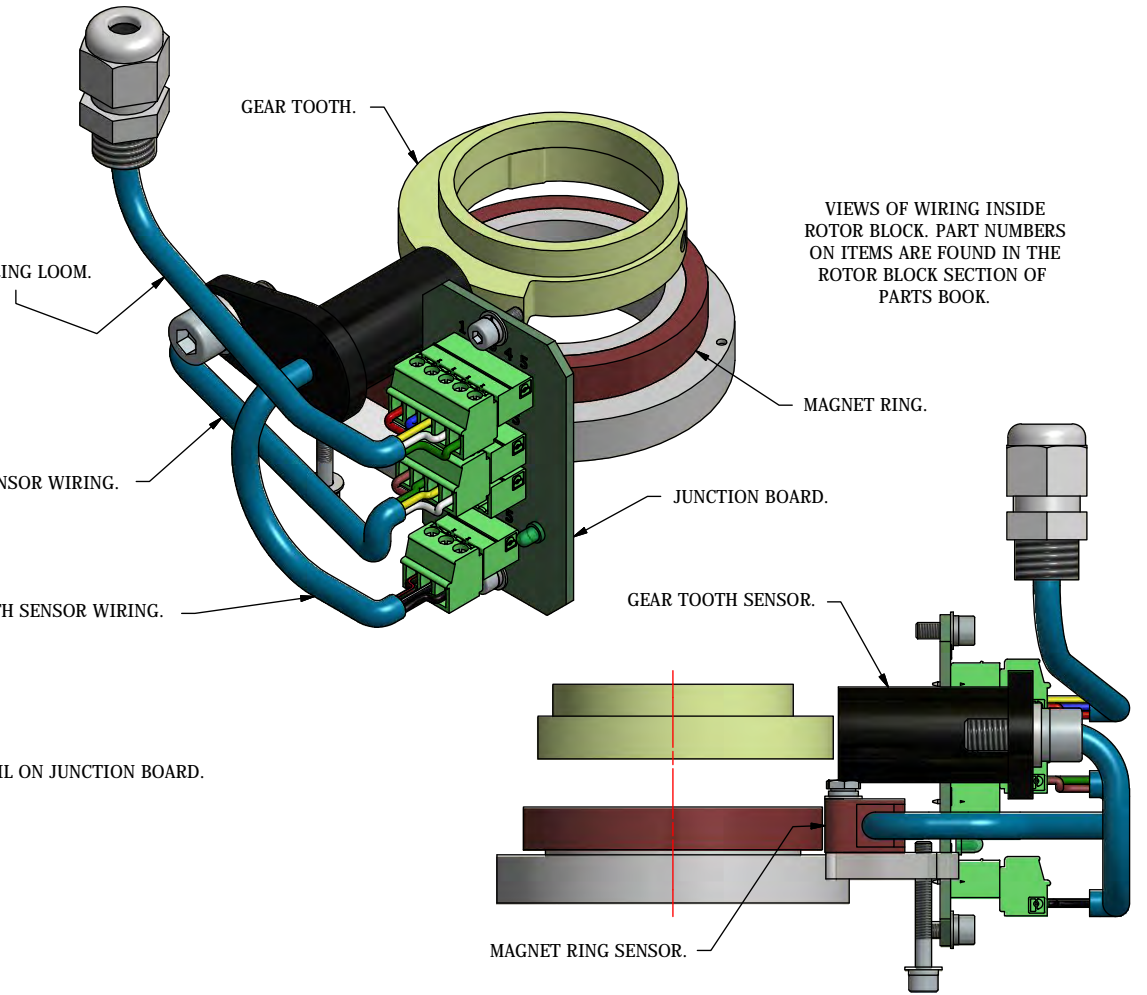

ROBOCROP IN ROW CONTROL SYSTEM

ITEM No.	DESCRIPTION	PART No.	QUANTITY
1	INROW CENTRAL PROCESSOR (CANBUS) MOUNT	10034.00	1
2	ROBO VIS SYS INROW CENTRAL PROCESSOR UNIT CAMBUS	10033.00	1
3	INROW CENTRAL PROCESSOR (CANBUS) MOUNT COVER	10035.00	1
4	INROW PROCESSOR JUNCTION BOX COVER	10128.01	1
5	INROW PROCESSOR JUNCTION BOX MOUNT	10127.01	1
6	ROBO VIS SYS CAN JUNCTION BOX	10126.00	1
7	ROBO VIS SYS INROW mk2, 4 WAY CAN & POWER LOOM	10595.00	1
8	ROBO VIS SYS INROW mk2, 12 WAY VALVE LOOM	10596.00	1
9	ROBO VIS SYS INROW mk2, 8 WAY VALVE LOOM	10597.00	1
10	RH ROTOR VALVE LOOM		1
11	LH ROTOR VALVE LOOM		1
12	ROBO VIS SYS INROW MK2 AUX POT LOOM	10598.00	1
13	CONTROL VACUUM BRACKET 2 PAD GREEN	7447.00	1
14	ROBO VIS SYS CONSOLE FIREWIRE	8500.00	1
15	ROBO VIS SYS INROW CONSOLE CABLE	9384.00	1
16	ROBO VIS SYS POWER LEAD	7797.00	1
17	FUSE SPADE TYPE 20A	7798.00	2
18	ROBO VIS SYS CONSOLE MOUNT PLATE	10571.00	1
19	CONTROL SYSTEM POWER CABLE		1
20	ROBO VIS SYS INROW mk2 CAMERA CABLE PLUG TO PLUG	10581.00	
21	ROBO VIS SYS CAMERA INROW WIDE ANGLE LENS	9709.00	
22	ROBO VIS SYS INROW mk2 31 WAY PLUG SENSOR LOOM	10594.00	1
23	INROW ENCODER (FITTED TO ENCODER WHEEL)	9347.00	
24	PROXIMITY SENSOR NPN PLUGGED (FITTED INTO LEVELLING SYSTEM & ENCODER WHEELS)	10121.00	
25	PROXIMITY CABLE WITH 90° PLUG 5M (FITTED INTO LEVELLING SYSTEM & ENCODER WHEELS)	10122.00	
26	JUNCTION BOXES		
27	ROBO VIS SYS INROW PRESSURE SENSOR	10587.00	1
28	ROBO VIS SYS INROW PRESSURE & TEMPERATURE SENSOR	10586.00	1
29	POTENTIOMETER ROTARY FOR DISK STEER	8674.00	
30	JUNCTION BOX (INSIDE DISK STEER MECHANISM)		1

NUMBER OF CAMERAS AND CAMERA LOOMS ARE MACHINE SPECIFIC

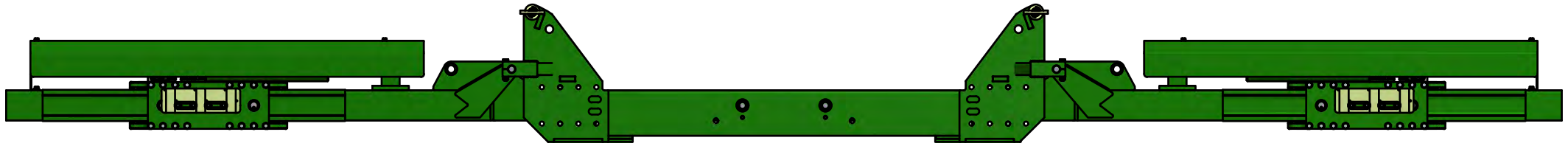

EXPLODED VIEW OF RIGHT HAND WING SHOWN BELOW.
 THE SAME PARTS ARE APPLICABLE TO THE LEFT HAND WING,
 THE ONLY DIFFERENCE IS THE WING PART NUMBER. SEE PARTS LIST.

NOTE : SYSTEMS MAY ALSO BE MACHINE SPECIFIC. ALWAYS REFER TO
 MACHINE SERIAL NUMBER

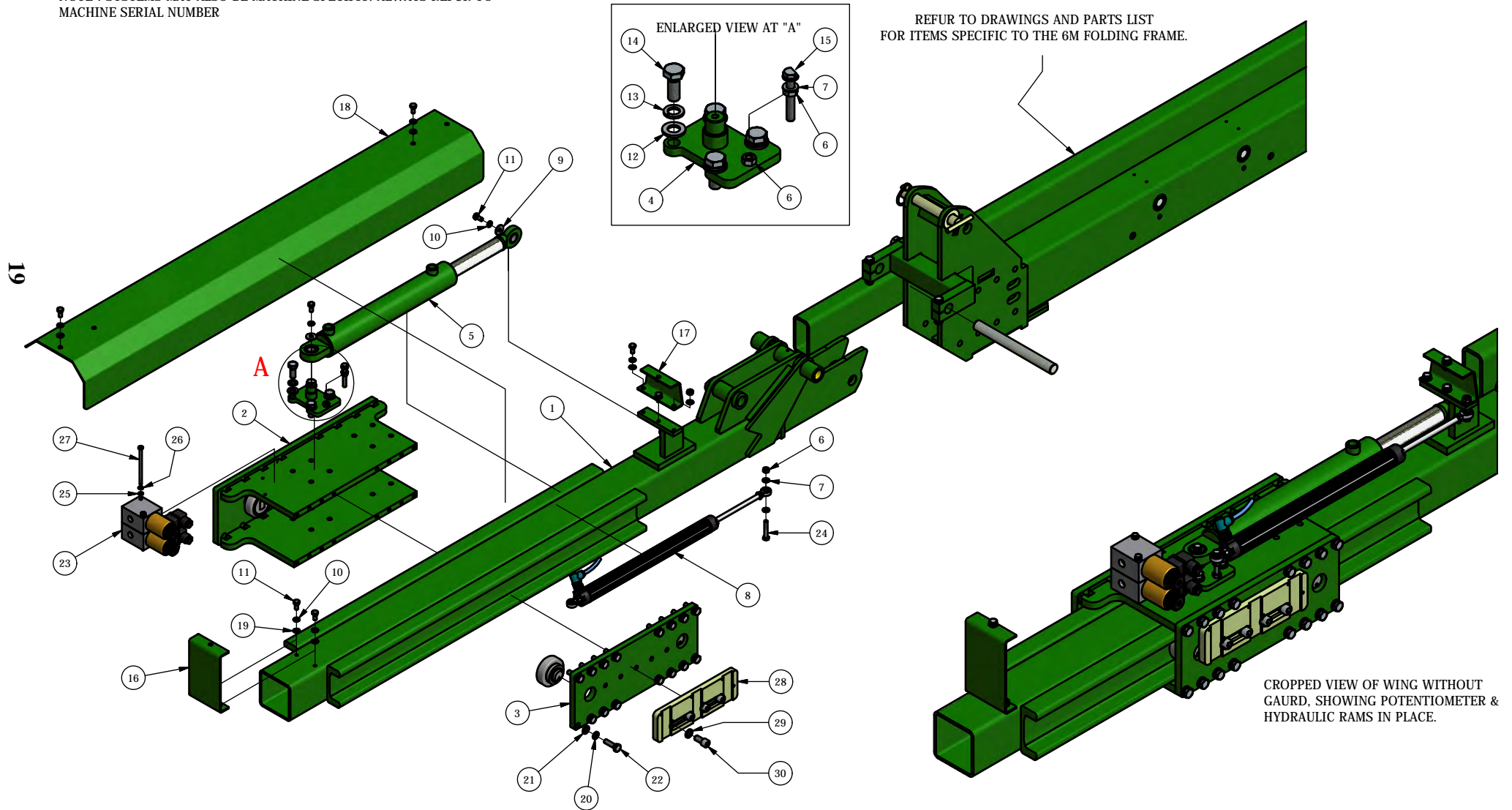

CROPPED VIEW OF WING WITHOUT
 GAURD, SHOWING POTENTIOMETER &
 HYDRAULIC RAMS IN PLACE.

ROBOCROP SIDESHIFT WING ASSEMBLY

ITEM No.	DESCRIPTION	PART No.	QUANTITY
1	RH FOLDING FRAME WING	9053.00	1
	LH FOLDING FRAME WING (NOT SHOWN)	9054.00	1
2	SIDE SHIFT SADDLE (WITH ROLLERS)	8469.00	2
3	SADDLE PLATE (WITH ROLLERS)	8470.00	2
4	SADDLE RAM MOUNT	8471.02	2
5	HYDRAULIC RAM	8235.00	2
6	M8 NUT BZP	1185	8
7	M8 FLAT WASHER BZP	1157	10
8	POTENTIOMETER RAM	7732.00	2
9	LARGE OD FLAT WASHER 8x24x2 BZP		4
10	M8 SPRING WASHER BZP	1154	16
11	M8x16 BOLT BZP	1156	16
12	M12 FLAT WASHER BZP	1114	8
13	M12 SPRING WASHER BZP	1115	8
14	M12x30 BOLT BZP	1161	8
15	M8x55 BOLT BZP	5832	2
16	GUARD SUPPORT	9228.00	2
17	GUARD SUPPORT	9229.00	2
18	WING GUARD	9227.00	2
19	M8 FLAT THIN WASHER BZP		12
20	M10 SPRING WASHER BZP	1170	32
21	M10 FLAT WASHER BZP	1186	32
22	M10x35 BOLT BZP	7466	32
23	2 WAY HYDRAULIC POPPET VALVE	8993.00	4
24	M8x45 BOLT BZP	8825	2
25	M6 FLAT THIN WASHER BZP	5978	4
26	M6 SPRING WASHER BZP	5979	4
27	M6x60 BOLT BZP	8822	4
28	CAMERA STEM BRACKET	9554.00	2
29	M12 SPRING WASHER BZP		8
30	M12x25 SOCKET HEAD CAP SCREW BZP		8

SECTION THRU TANK SHOWING FILTER, LID & BREATHER.

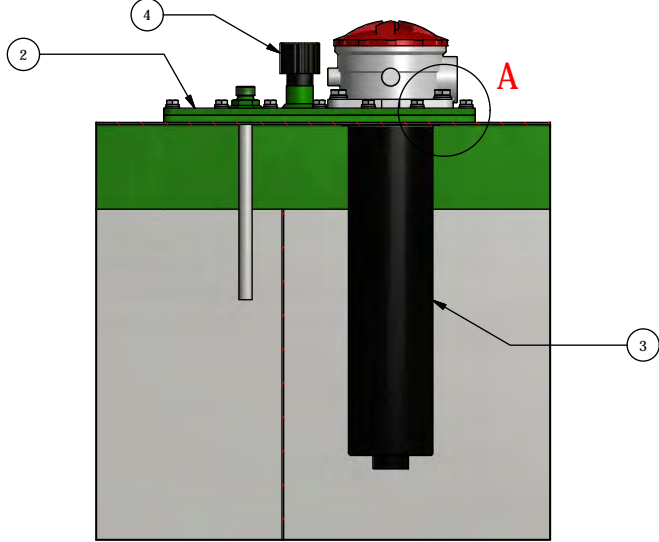

ENLARGED VIEW AT 'A'

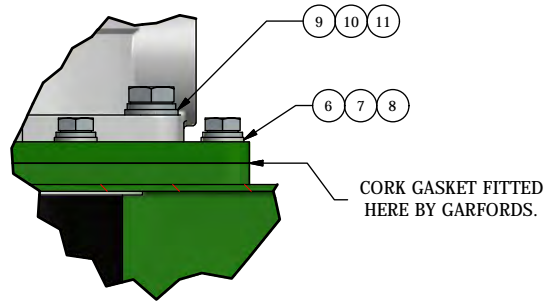

CROPPED SIDE VIEW AT TANK SHOWING FIXING BOLTS.

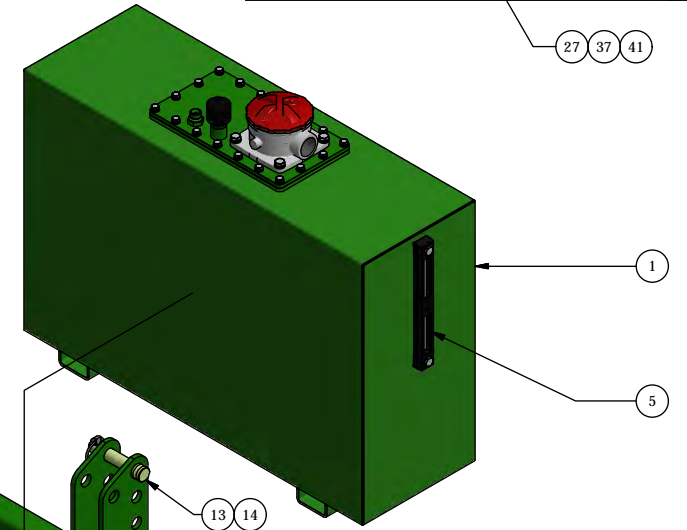
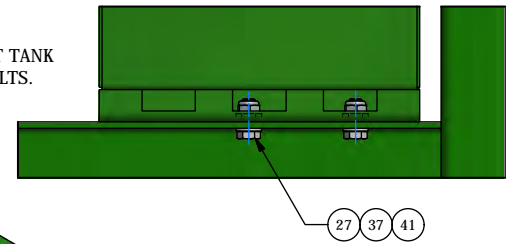

21

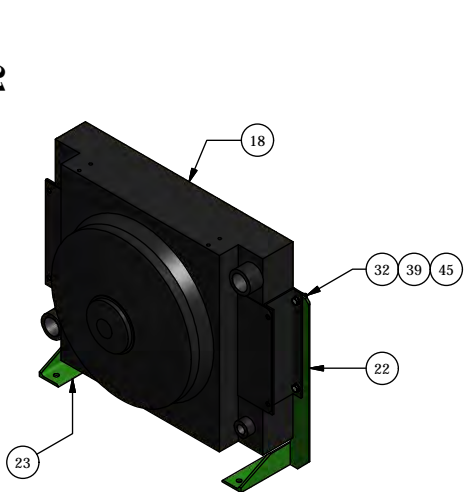

ALTERNATIVE OIL COOLER FITTED TO LEGS.

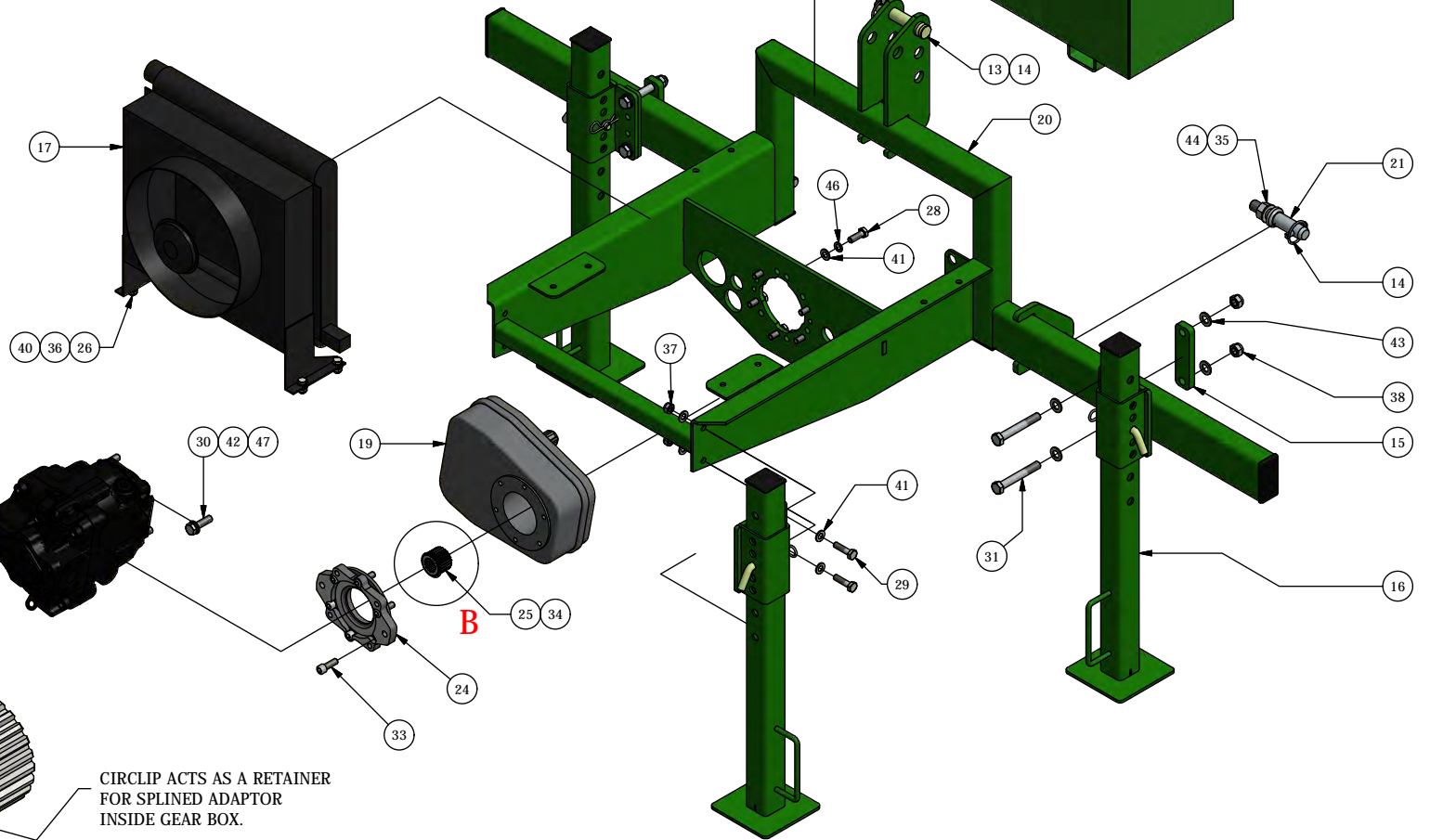

B

ENLARGED VIEW AT 'B'

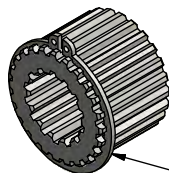

CIRCLIP ACTS AS A RETAINER FOR SPLINED ADAPTOR INSIDE GEAR BOX.

ROBOCROP IN ROW POWER PACK ASSEMBLY

ITEM No.	DESCRIPTION	PART No.	QUANTITY
1	OIL TANK	10372.00	1
2	OIL TANK LID	10373.00	1
3	FILTER	10012.00	1
4	BREATHER	10015.00	1
5	OIL SIGHT & TEMPERATURE LEVEL	10014.00	1
6	M8 WASHER BZP		18
7	M8 SPRING WASHER BZP		18
8	M8x20 BOLT BZP		18
9	M10 WASHER BZP		4
10	M10 SPRING WASHER BZP		4
11	M10x25 BOLT BZP		4
12	PUMP	10375.00	1
13	TOP LINK PIN	5442.00	1
14	LINCH PIN	5604.00	3
15	CLAMP PLATE	7405.00	2
16	STAND ASSEMBLY (IN PREVIOUS SECTION OF BOOK)		3
17	OIL COOLER	9295.00	1
18	OIL COOLER	9295.01	1
19	GEAR BOX	9448.00	1
20	POWER PACK FRAME	9528.01	1
21	CAT2 MOUNTING PIN	9529.00	2
22	OIL COOLER BRACKET	9568.00	1
23	OIL COOLER BRACKET	9569.00	1
24	ADAPTOR PLATE	9748.00	1
25	SPLINED ADAPTOR	9750.00	1
26	M10x25 BOLT BZP		4
27	M12x30 BOLT BZP		4
28	M12x35 BOLT BZP		6
29	M12x45 BOLT BZP		2
30	M14x50 BOLT BZP		4
31	M16x110 BOLT BZP		4
32	M8x25 BOLT BZP		4
33	M12x35 SOCKET HEAD CAP SCREW BZP		6
34	50mm EXTERNAL CIRCLIP		1
35	M22 NUT BZP		2
36	M10 NYLOC NUT BZP		4
37	M12 NYLOC NUT BZP		6
38	M16 NYLOC NUT BZP		4
39	M8 NYLOC NUT BZP		4
40	M10 WASHER BZP		8
41	M12 WASHER BZP		18
42	M14 WASHER BZP		4
43	M16 WASHER BZP		8
44	M22 WASHER BZP		2
45	M8 WASHER BZP		8
46	M12 SPRING WASHER BZP		6
47	M14 SPRING WASHER BZP		4

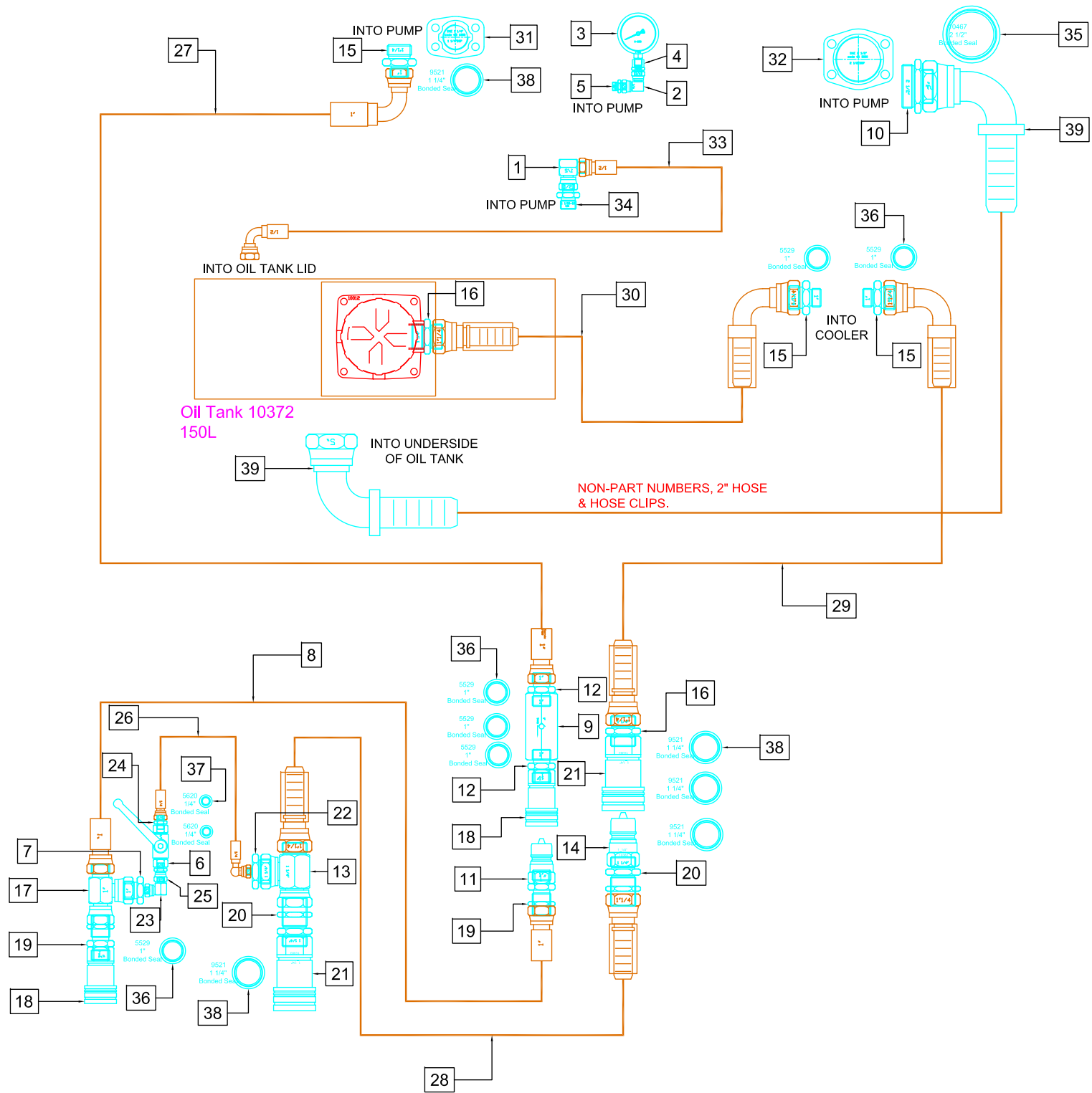

ROBOCROP IN ROW POWER PACK HYDRAULIC ITEMS

ITEM No.	DESCRIPTION	PART No.	QUANTITY
1	HYDRAULIC FITTING	8518.00	1
2	HYDRAULIC FITTING	7939.00	1
3	PRESSURE GAUGE	7735.00	1
4	PRESSURE GAUGE ADAPTOR	7618.00	1
5	HYDRAULIC FITTING	8913.00	1
6	2 WAY BALL VALVE	7424.00	1
7	HYDRAULIC FITTING	9444.00	1
8	HISE ASSEMBLY	9363.00	1
9	INLINE CHECK VALVE	9446.00	1
10	HYDRAULIC FITTING	10381.00	1
11	QUICK RELEASE	7947.00	1
12	HYDRAULIC FITTING	5400.00	2
13	HYDRAULIC FITTING – TEE	10024.00	1
14	QUICK RELEASE	10382.00	1
15	HYDRAULIC FITTING	6770.00	3
16	HYDRAULIC FITTING	7925.00	2
17	HYDRAULIC FITTING – TEE	7944.00	1
18	QUICK RELEASE	7945.00	2
19	BULKHEAD	9443.00	2
20	BULKHEAD	10385.00	2
21	QUICK RELEASE	10383.00	2
22	HYDRAULIC FITTING	10384.00	1
23	HYDRAULIC FITTING	6720.00	1
24	HYDRAULIC FITTING	7422.00	1
25	HYDRAULIC FITTING – SWIVEL	7617.00	1
26	HOSE ASSEMBLY	10043.00	1
27	HOSE ASSEMBLY	10386.00	1
28	HOSE ASSEMBLY	10388.00	1
29	HOSE ASSEMBLY	10387.00	1
30	HOSE ASSEMBLY	10081.00	1
31	FLANGE	10391.00	1
32	FLANGE	10392.00	1
33	HOSE ASSEMBLY	6739.00	1
34	HYDRAULIC FITTING	10402.00	1
35	BONDED SEAL	10467.00	1
36	BONDED SEAL	5529.00	6
37	BONDED SEAL	5620.00	2
38	BONDED SEAL	9521.00	5
39	HYDRAULIC FITTING	9440.00	2

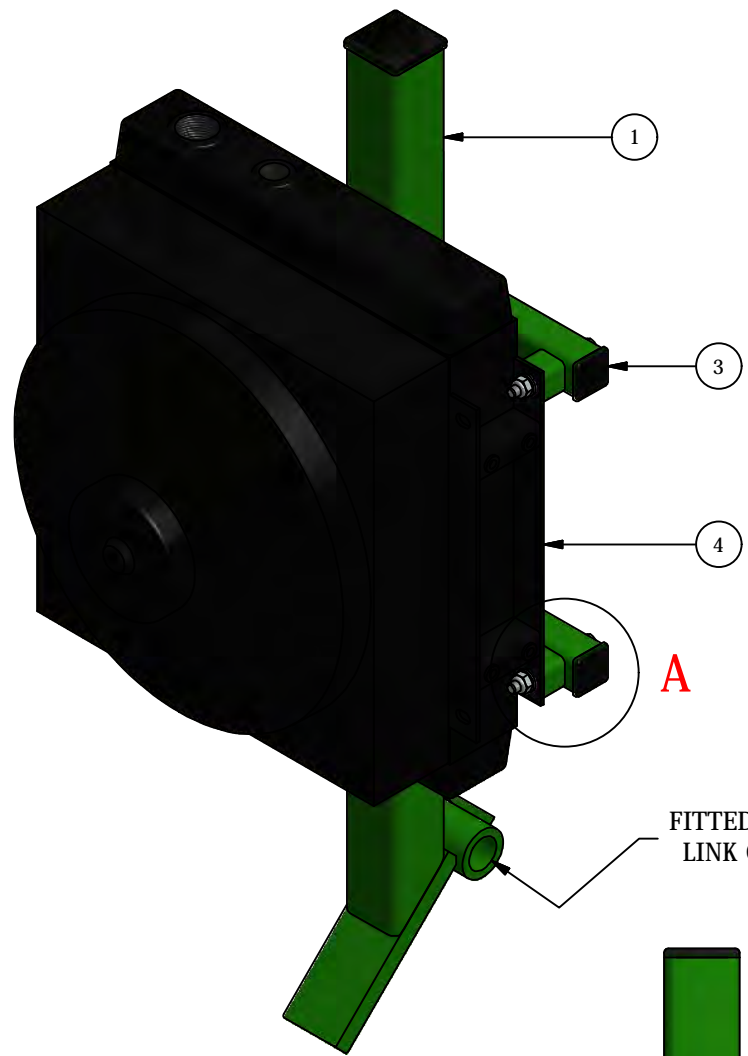

FITTED TO REAR TOP LINK ON TRACTOR.

25

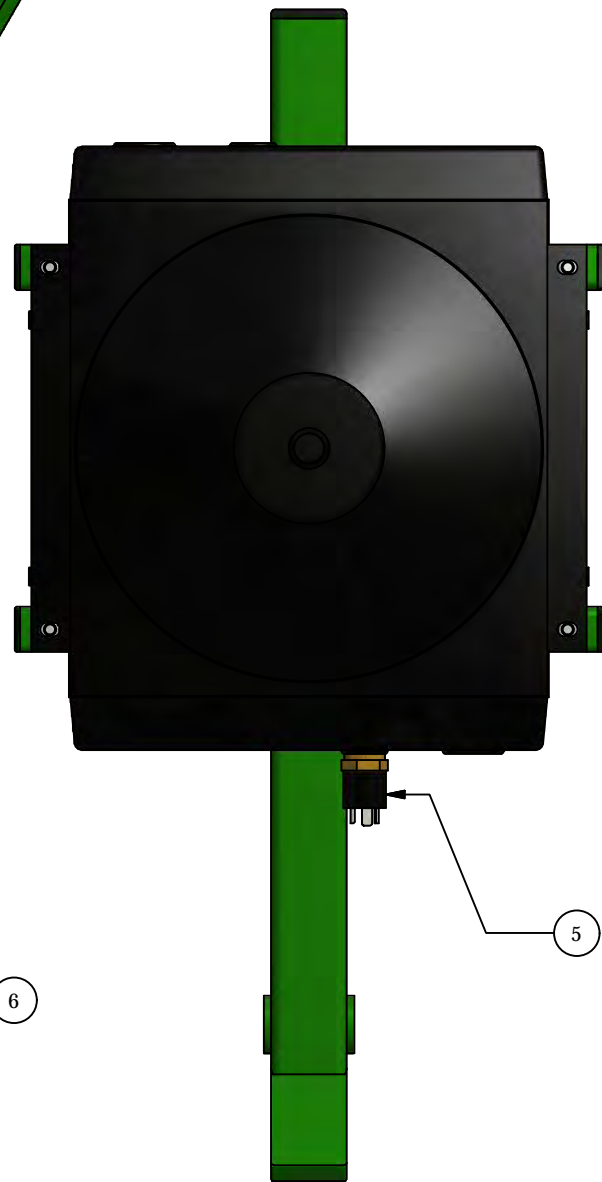

ENLARGED VIEW AT 'A'

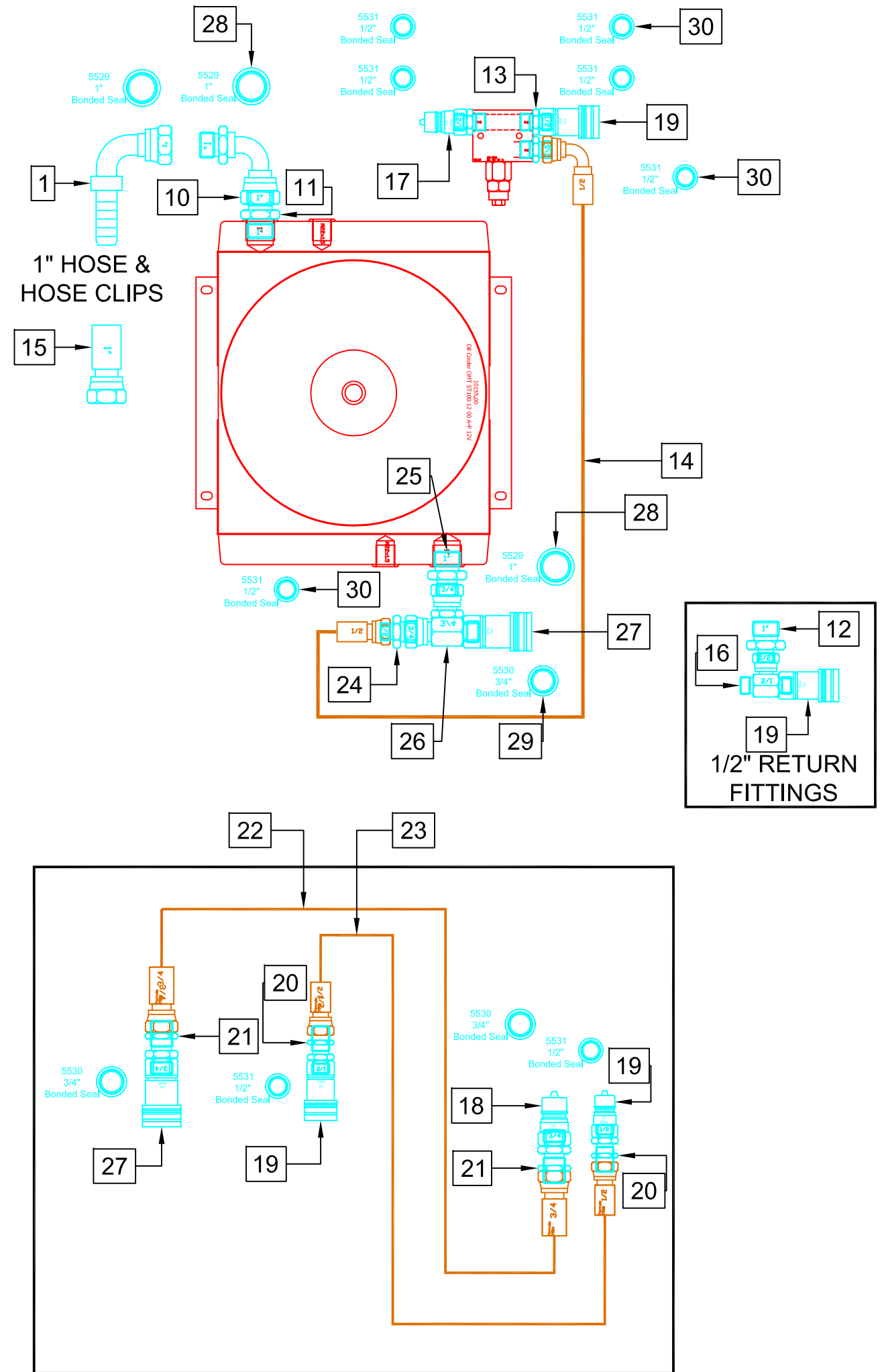
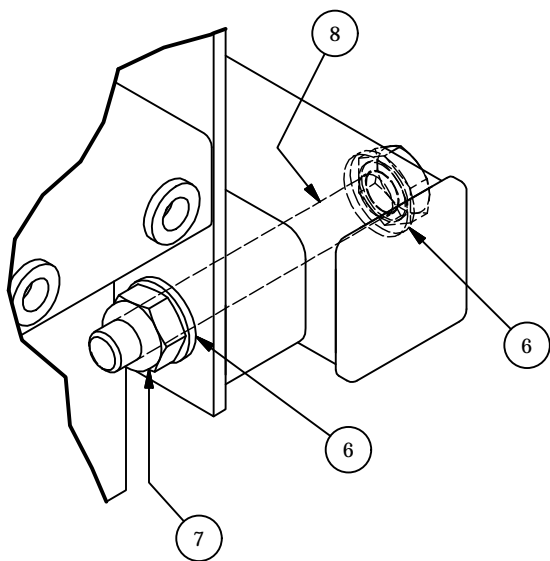

ROBOCROP IN ROW REAR COOLER ASSEMBLY

ITEM No.	DESCRIPTION	PART No.	QUANTITY
1	COOLER MOUNT	10154.00	1
2	END CAP	7501.00	1
3	END CAP	8839.00	4
4	OIL COOLER	10155.00	1
5	THERMO SWITCH	10156.00	1
6	M8 WASHER BZP		8
7	M8 NYLOC NUT BZP		4
8	M8x70 BOLT BZP		4
9	HYDRAULIC FITTING	6733.00	1
10	HYDRAULIC FITTING	5401.00	1
11	HYDRAULIC FITTING	5400.00	1
12	HYDRAULIC FITTING	5405.00	1
13	HYDRAULIC FITTING	5412.00	3
14	HOSE ASSEMBLY	10063.00	1
15	HYDRAULIC FITTING	5388.00	1
16	HYDRAULIC FITTING – TEE	8571.00	1
17	QUICK RELEASE	5534.00	2
18	QUICK RELEASE	5421.00	1
19	QUICK RELEASE	7053.00	3
20	HYDRAULIC FITTING – BULKHEAD	7492.00	2
21	HYDRAULIC FITTING - BULKHEAD	5411.00	2
22	HOSE ASSEMBLY	8916.00	1
23	HOSE ASSEMBLY	8915.00	1
24	HYDRAULIC FITTING	5413.00	1
25	HYDRAULIC FITTING	5523.00	1
26	HYDRAULIC FITTING – TEE	7871.00	1
27	QUICK RELEASE	5420.00	2
28	BONDED SEAL	5529.00	3
29	BONDED SEAL	5530.00	3
30	BONDED SEAL	5531.00	8

ADJUSTABLE WHEEL UNIT PARTS SECTION

CONTENTS

	PAGE
ROBOCROP IN ROW SUPPORT WHEEL ASSEMBLY	1-2
ROBOCROP IN ROW WHEEL LEGS 50MM & 100MM	3-4
ROBOCROP IN ROW BALANCE SUPPORT ARM	5-6
ROBOCROP DISK STEER UNIT – EXPLODED DRAWINGS	7-8
ROBOCROP DISK STEER ASSEMBLY	9-10
ROBOCROP DISK STEER WHEEL ASSEMBLY	11-12
ROBOCROP DISK STEER MECHANISM	13-14
ROBOCROP ADJSUTABLE DEPTH IN ROW WHEEL LEG	15-16
ROBOCROP ADJSUATBLE WHEEL LEGS 50MM & 100MM	17-18
ROBOCROP HEAVY DUTY ADJSUATBLE WHEEL LEG	19-20
ROBOCROP HEAVY DUTY ADJUSTABLE WHEEL LEG WITH RETRACTING RAM	21-22
ROBOCROP ENCODER WHEEL ASEMBLY	23-24
ROBOCROP LARGE ENCODER WHEEL ASSEMBLY	25-26
ROBOCROP DISK STEER FRAME MOUNT BRACKET	27-28
ROBOCROP WHEEL ASSEMBLY FRAME CLAMPS	29-30

<CLICK> TO RETURN TO MAIN SUB SECTION CONTENTS PAGE

LONG REACH SUPPORT WHEEL
FOR FOLDING FRAME MACHINES.

SPRING LIFT BRACKET

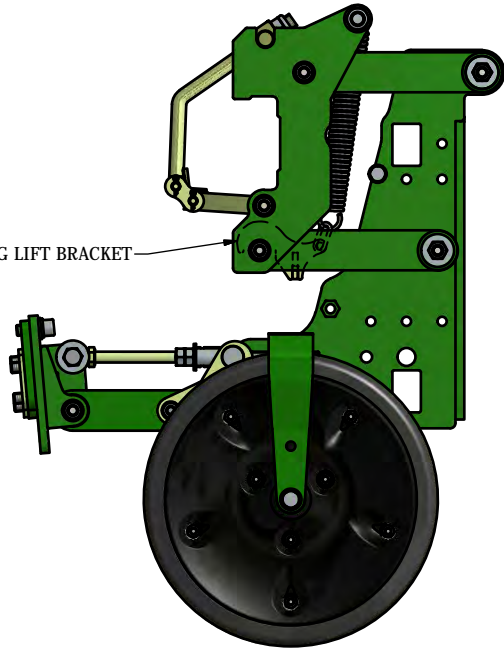

FRAME CLAMP AVAILABLE
FOR 100x50 FRAME BOX SECTION.

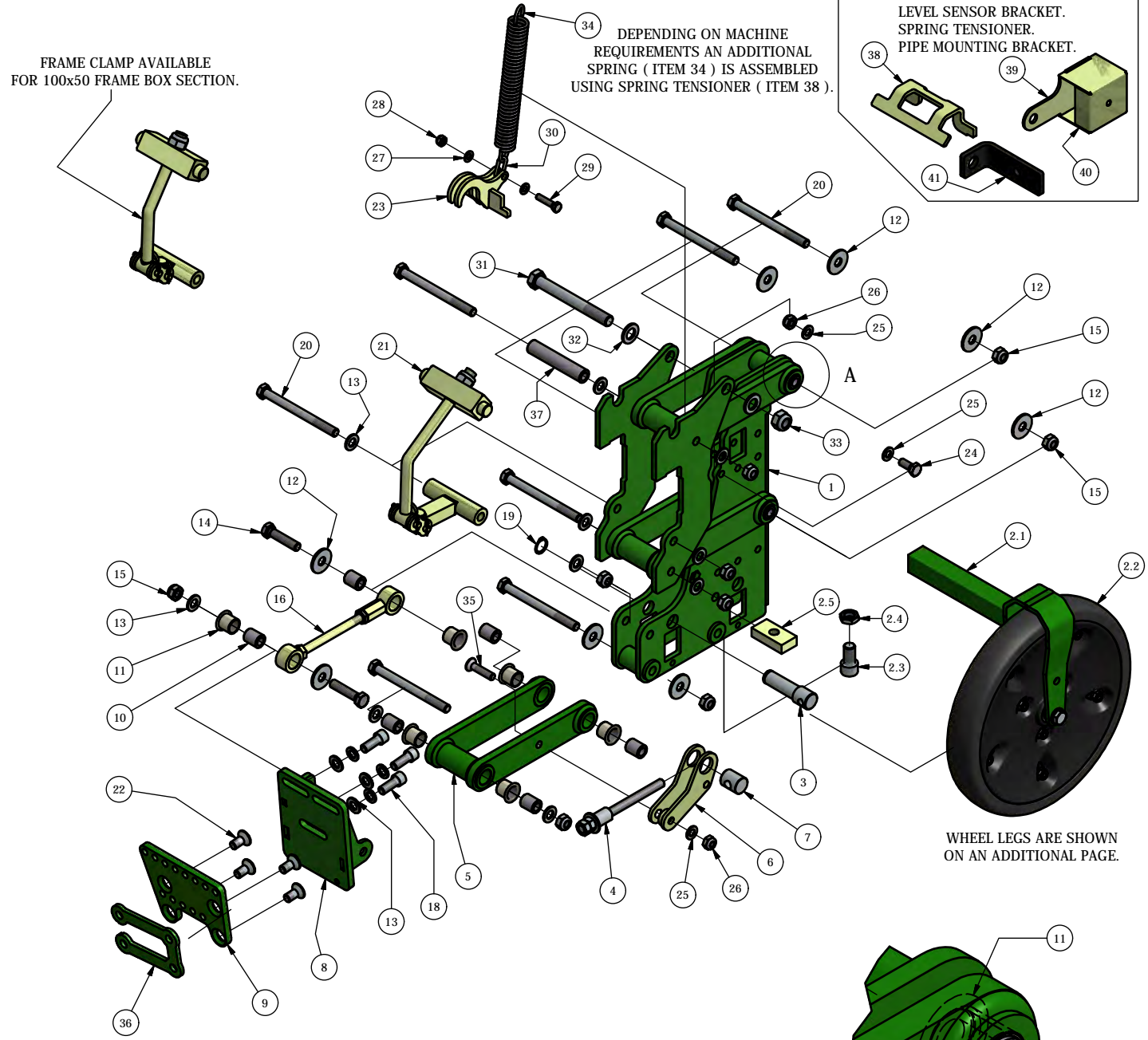
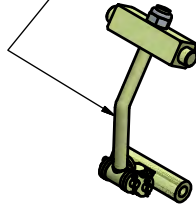

DEPENDENT ON MACHINE
REQUIREMENTS AN ADDITIONAL
SPRING (ITEM 34) IS ASSEMBLED
USING SPRING TENSIONER (ITEM 38).

ADDITIONAL ITEMS :-
LEVEL SENSOR BRACKET.
SPRING TENSIONER.
PIPE MOUNTING BRACKET.

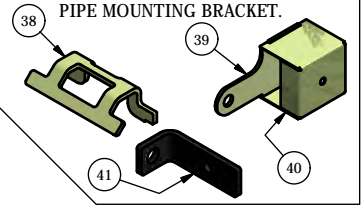

1

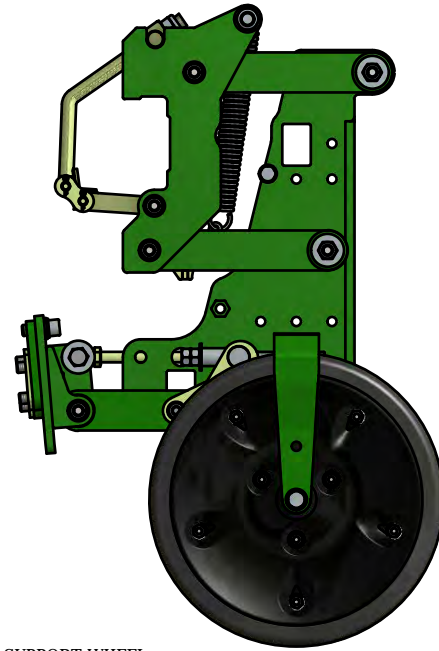

SHORT REACH SUPPORT WHEEL
FOR NON-FOLDING FRAME MACHINES.

WHEEL LEGS ARE SHOWN
ON AN ADDITIONAL PAGE.

ENLARGED VIEW AT 'A'
LINK BUSHES

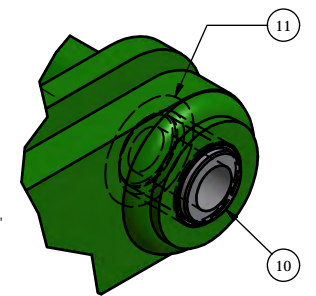

ROBOCROP IN ROW SUPPORT WHEEL ASSEMBLY

ITEM No.	DESCRIPTION	PART No.	QUANTITY
1	SUPPORT WHEEL UNIT	8614.02	1
ITEMS 2.1 TO 2.5 AS FOLLOWS:-			
2.1	WHEEL LEG	8623.00	1
2.2	65MM WHEEL	7599.00	1
2.3	SOCKET CAP SCREW M16x30 BZP		1
2.4	M16 HEX. HALF NUT BZP		1
2.5	SUPPORT WHEEL CLAMP PLATE	8622.00	1
3	ADJUSTMENT RETAINING PIN	8616.00	1
4	DEPTH ADJUSTMENT BOLT	8618.00	1
5	PARALLEL LINK	9147.00	1
6	DEPTH CONTROL LINK	8615.00	1
7	DEPTH ADJUSTMENT BUSH	8617.00	1
8	LINKAGE MOUNTING PLATE	8619.00	1
9	ROTOR MOUNTING PLATE	9810.00	1
10	PARALLEL LINK BUSH	8184.00	6
11	BUSH	8185.02	6
12	LARGE OD WASHER 12x37x3 BZP		8
13	M12 FLAT WASHER BZP		13
14	M12x55 BOLT BZP		2
15	M12 NYLOC NUT BZP		9
16	ADJUSTABLE PARALLEL LINK	8725.00	1
17	M12 SPRING WASHER BZP		3
18	SOCKET CAP SCREW M12x30 BZP		3
19	20MM EXTERNAL CIRCLIP		1
20	M12x40 BOLT BZP		7
21	FRAME CLAMP	7537.00	1
22	C'SUNK ALLEN HEAD SCREW M12x25 BZP		4
23	SPRING LIFT BRACKET	8544.00	1
24	M10x25 BOLT BZP		2
25	M10 FLAT WASHER BZP		5
26	M10 NYLOC NUT BZP		3
27	M8 FLAT WASHER BZP		2
28	M8 NYLOC NUT BZP		1
29	M8x35 BOLT BZP		1
30	CHAIN LINK		1
31	M16x140 BOLT BZP		1
32	M16 FLAT WASHER BZP		2
33	M16 NYLOC NUT BZP		1
34	TENSION SPRING	5536.00	1
35	C'SUNK ALLEN HEAD SCREW M10x45 BZP		1
36	SPACER	9811.00	1
37	BUSH SHAFT	8183.00	2
38	SPRING TENSIONER	9716.00	1
39	LEVEL SENSOR BRACKET	8988.00	2
40	LEVEL SENSOR GUARD	8989.00	2
41	PIPE MOUNTING BRACKET	9331.00 OR 10711.00	1
(107711.00 IS USED WITH BALANCE SUPPORT ARM – APPLICATION SPECIFIC)			
ITEMS 39 & 40 QTY IS PER MACHINE			

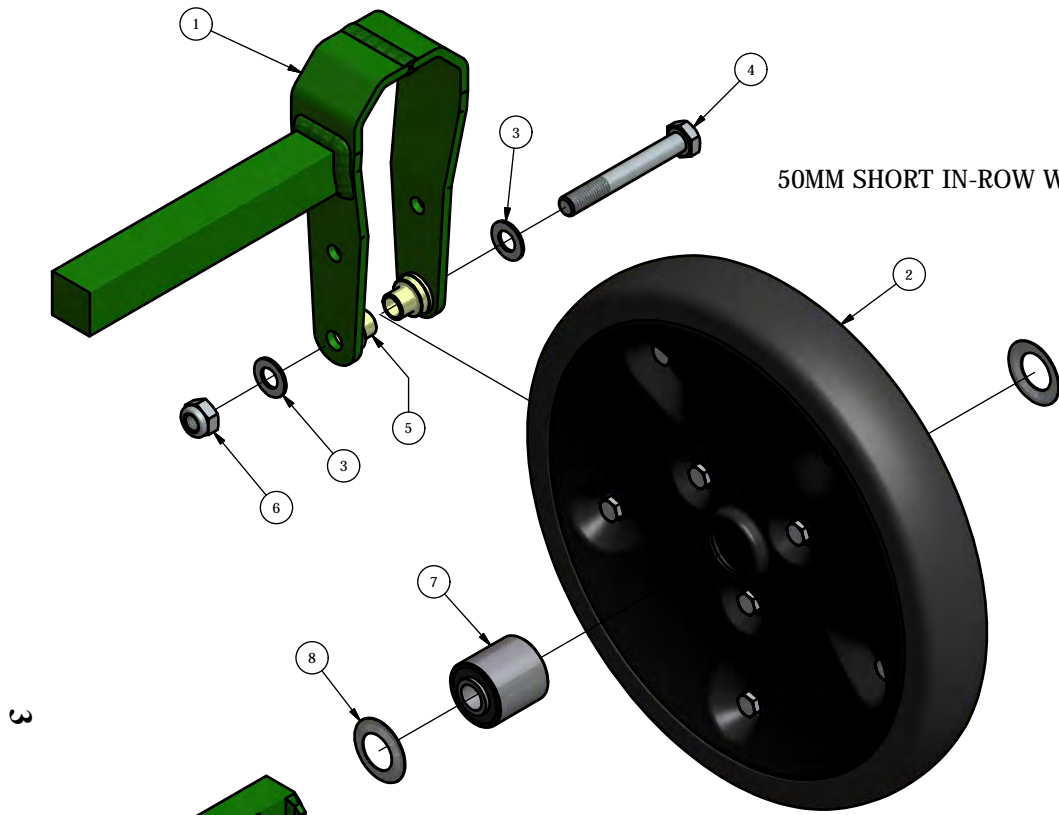

50MM SHORT IN-ROW WHEEL LEG ASSEMBLY

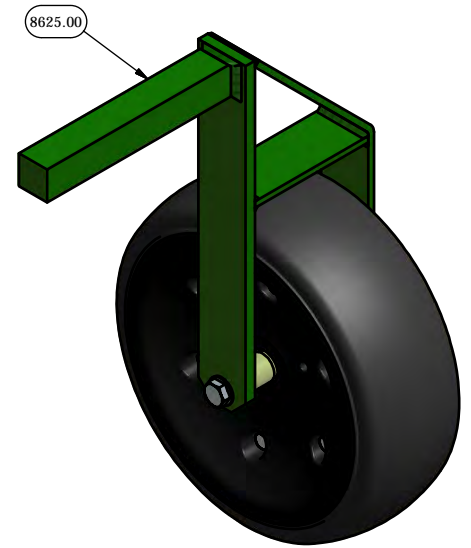

100MM LONG IN-ROW WHEEL LEG ASSEMBLY

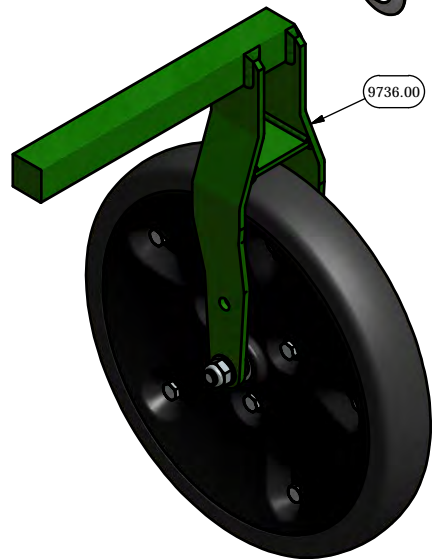

50MM LONG IN-ROW WHEEL LEG ASSEMBLY

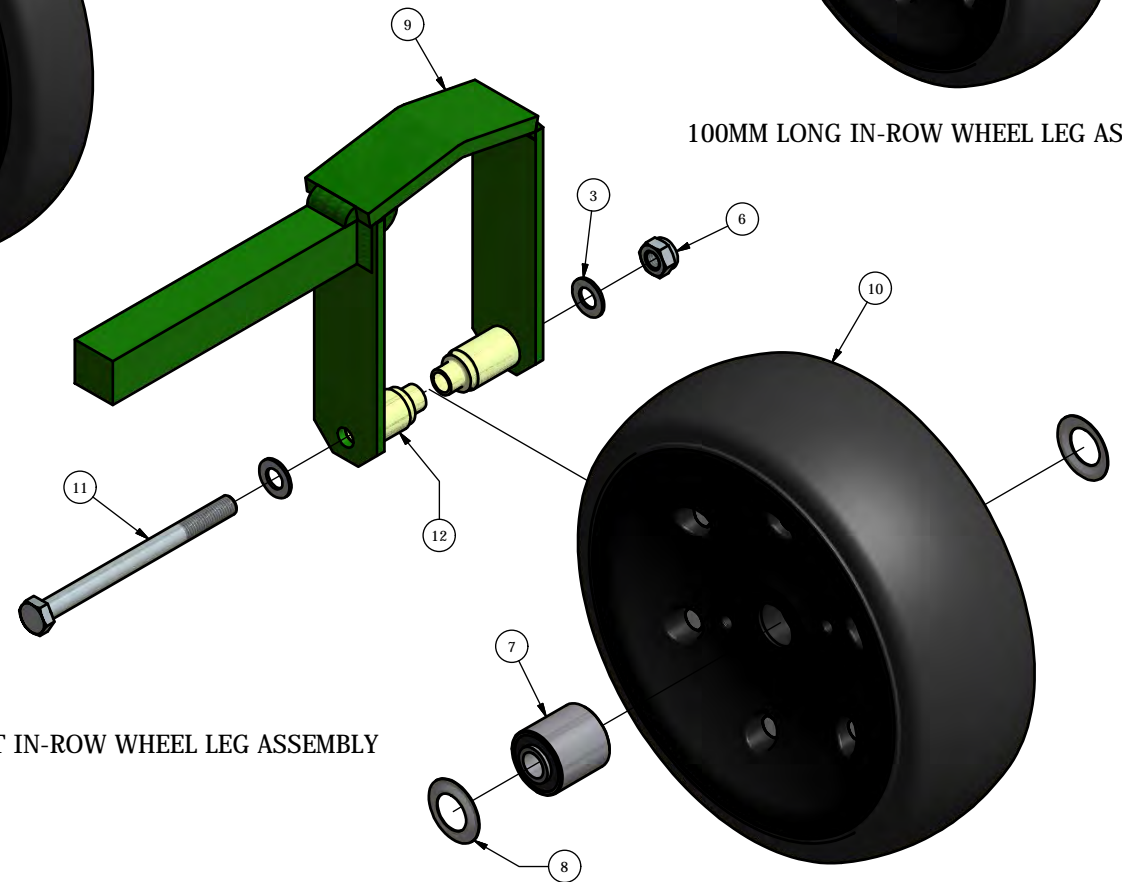

100MM SHORT IN-ROW WHEEL LEG ASSEMBLY

ROBOCROP IN ROW WHEEL LEGS 50MM & 100MM

ITEM No.	DESCRIPTION	PART No.	QUANTITY
1	50MM SHORT LEG ASS'Y	9735.00	1
2	50MM WHEEL	9708.00	1
3	M12 THIN WASHER BZP	7877	2
4	M12x90 BOLT BZP	1178	1
5	WHEEL SPACER	9733.00	2
6	M12 NYLOC NUT	1017	1
7	WHEEL BEARING	9511.00	1
8	BEARING SHIELDS	9733.00	2
9	100MM SHORT LEG ASS'Y	8699.00	1
10	100MM WHEEL	9731.00	1
11	M12x150 BOLT BZP	6395	1
12	WHEEL SPACER	9749.00	2

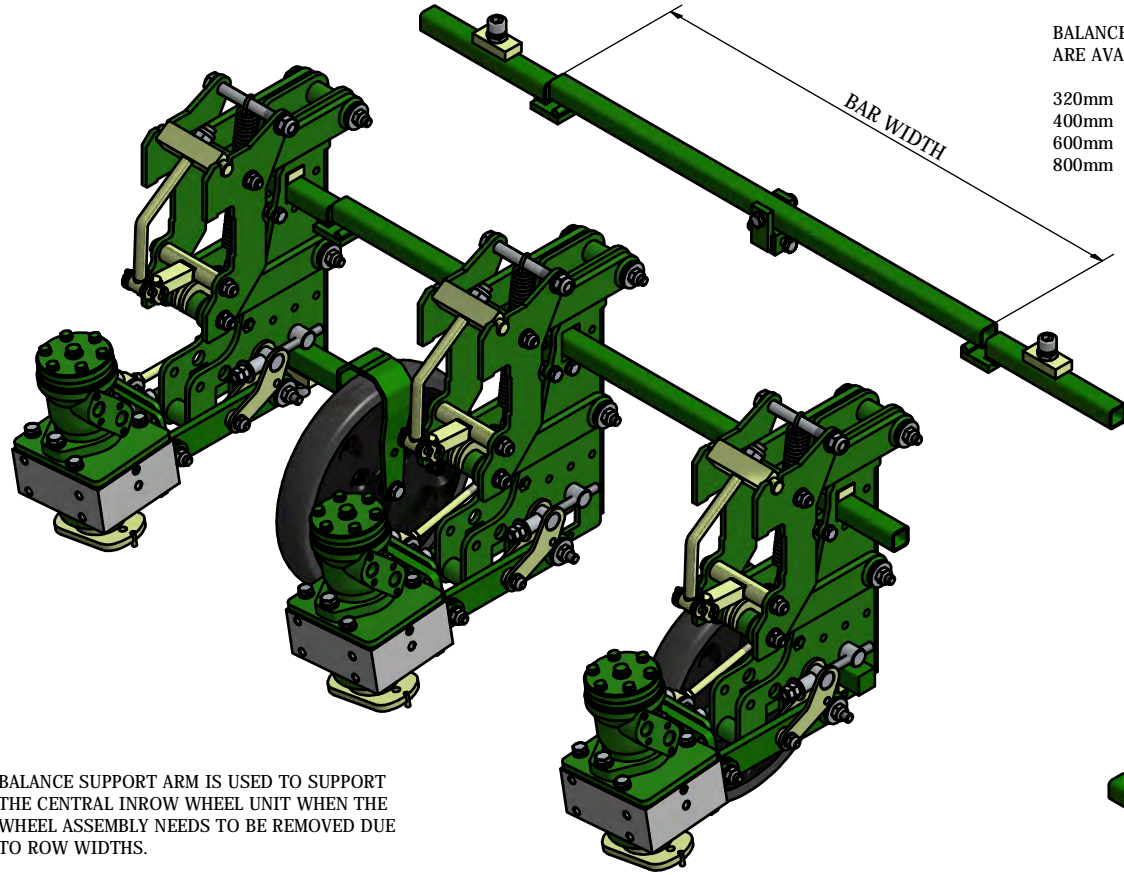

BALANCE SUPPORT ARM BAR WIDTHS
ARE AVAILABLE IN THE FOLLOWING LENGTHS :-

- 320mm
- 400mm
- 600mm
- 800mm

BALANCE SUPPORT ARM IS USED TO SUPPORT THE CENTRAL INROW WHEEL UNIT WHEN THE WHEEL ASSEMBLY NEEDS TO BE REMOVED DUE TO ROW WIDTHS.

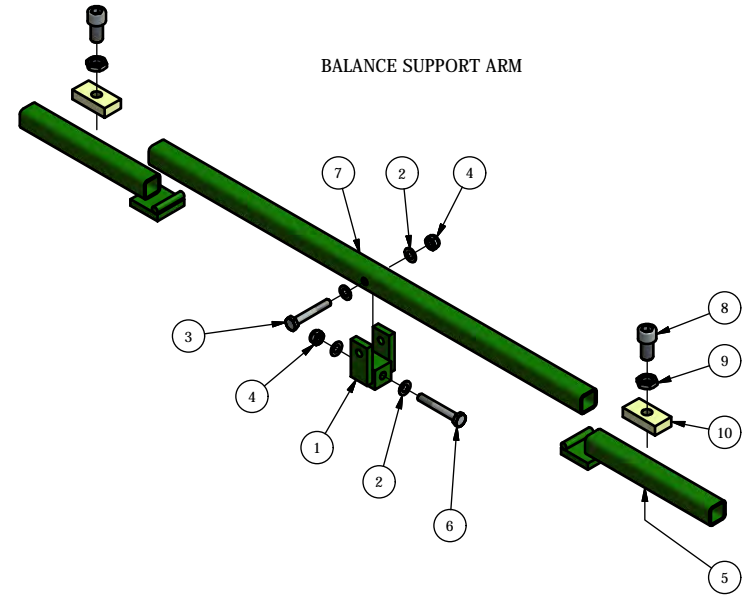
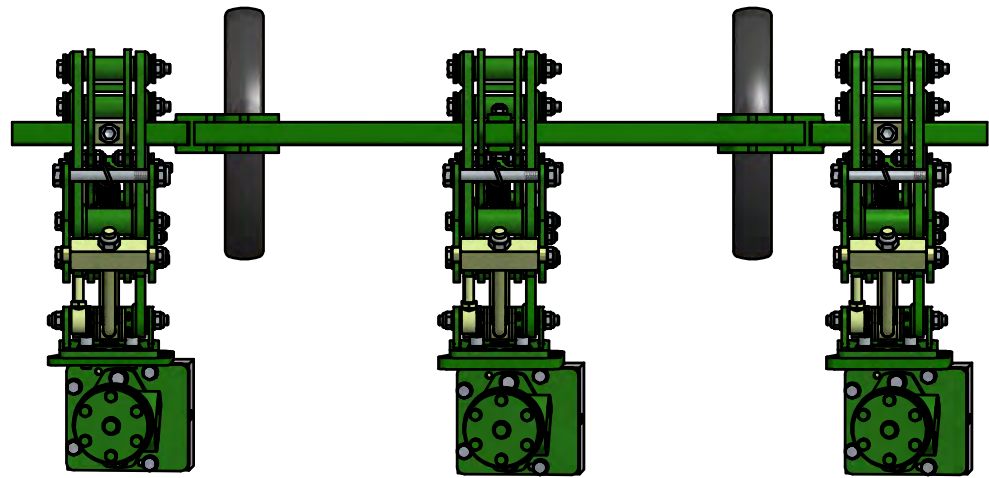

BALANCE SUPPORT ARM

ROBOCROP IN ROW BALANCE SUPPORT ARM

ITEM No.	DESCRIPTION	PART No.	QUANTITY
1	BALANCE SUPPORT PIVOT	8666.00	1
2	M10 THIN WASHER BZP	7876	4
3	M10x70 BOLT BZP	7459	1
4	M10 NYLOC NUT BZP	1024	2
5	BALANCE BAR SUPPORT	8665.00	2
6	M10x70 BOLT BZP	7459	1
7	BALANCE SUPPORT ARM (SPECIFY LENGTH)	8664.00	1
8	SOCKET CAP SCREW M16x30 BZP	8886	2
9	M16 HEX. HALF NUT BZP	6865	2
10	SUPPORT WHEEL CLAMP PLATE	8622.00	2

INROW DISK STEER UNIT :-
THE 3 MAIN SUB-ASSEMBLIES ARE
SHOWN PARTIALLY EXPLODED FOR
IDENTIFICATION PURPOSES.

DISK STEER UNITS AVAILABLE IN
RIGHT & LEFT HAND VERSIONS.

DISK STEER MECHANISM

DISK STEER ASSEMBLY

DISK STEER WHEEL ASSEMBLY

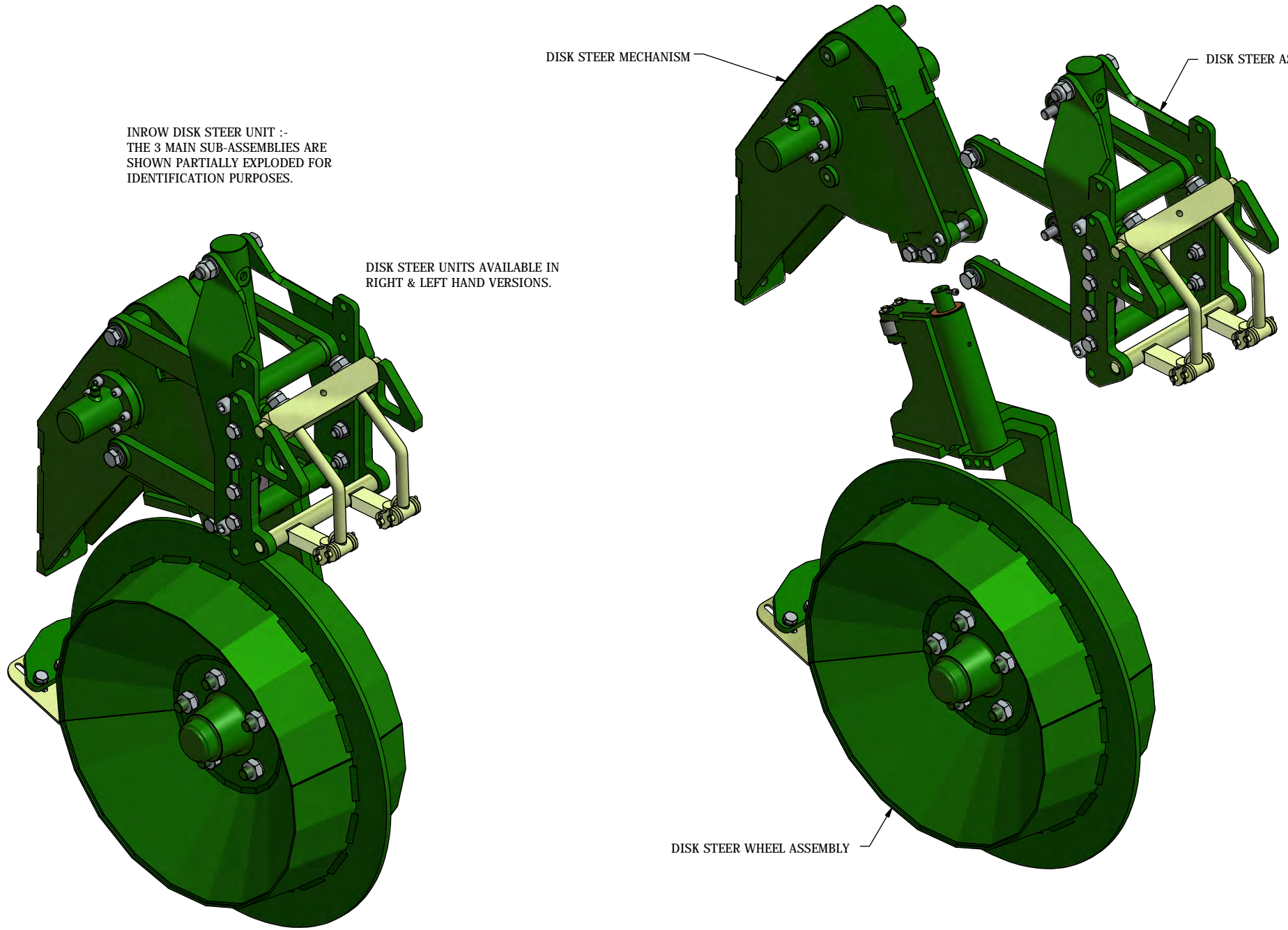

DISK STEER MECHANISM, EXPLODED VIEW.

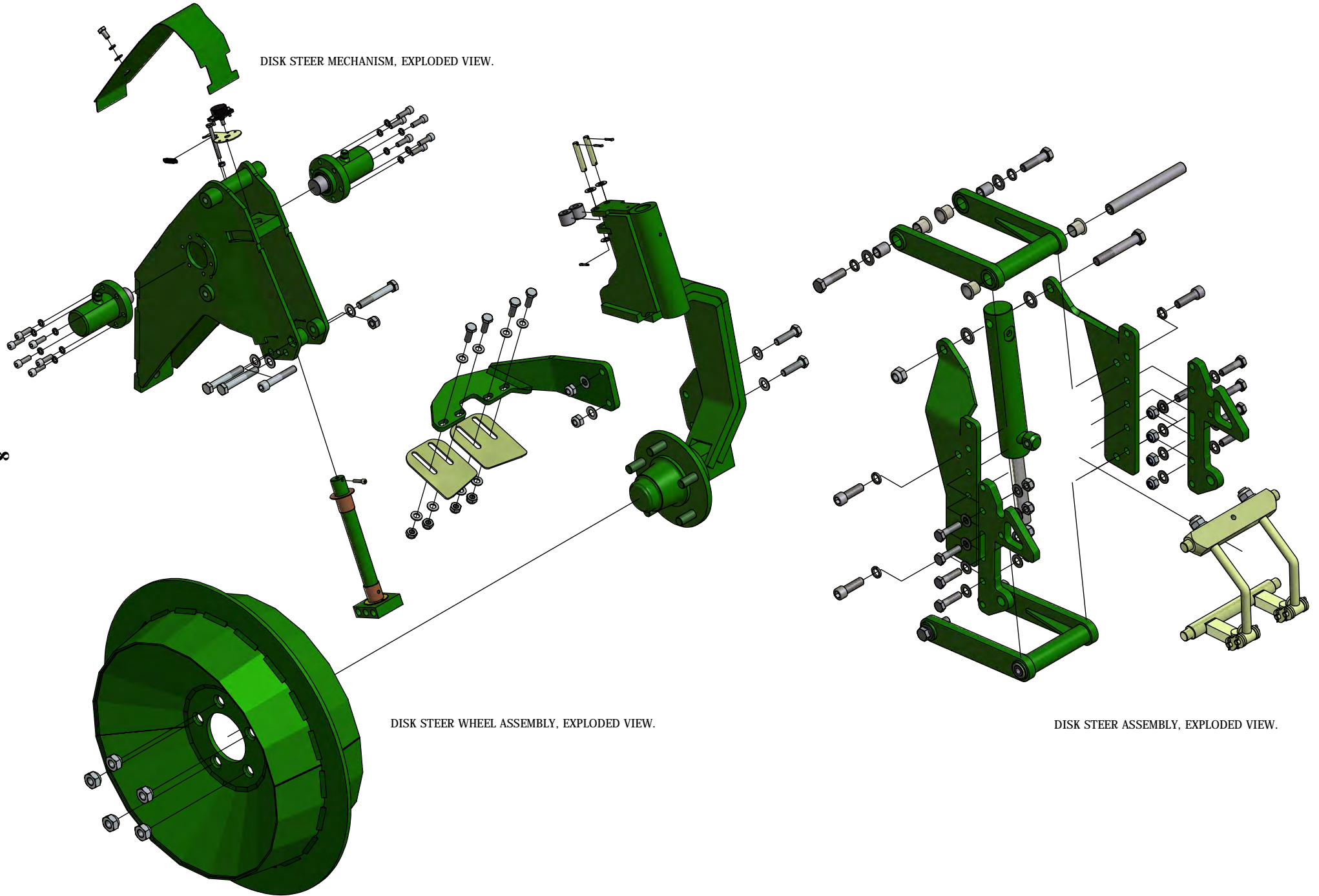

DISK STEER WHEEL ASSEMBLY, EXPLODED VIEW.

DISK STEER ASSEMBLY, EXPLODED VIEW.

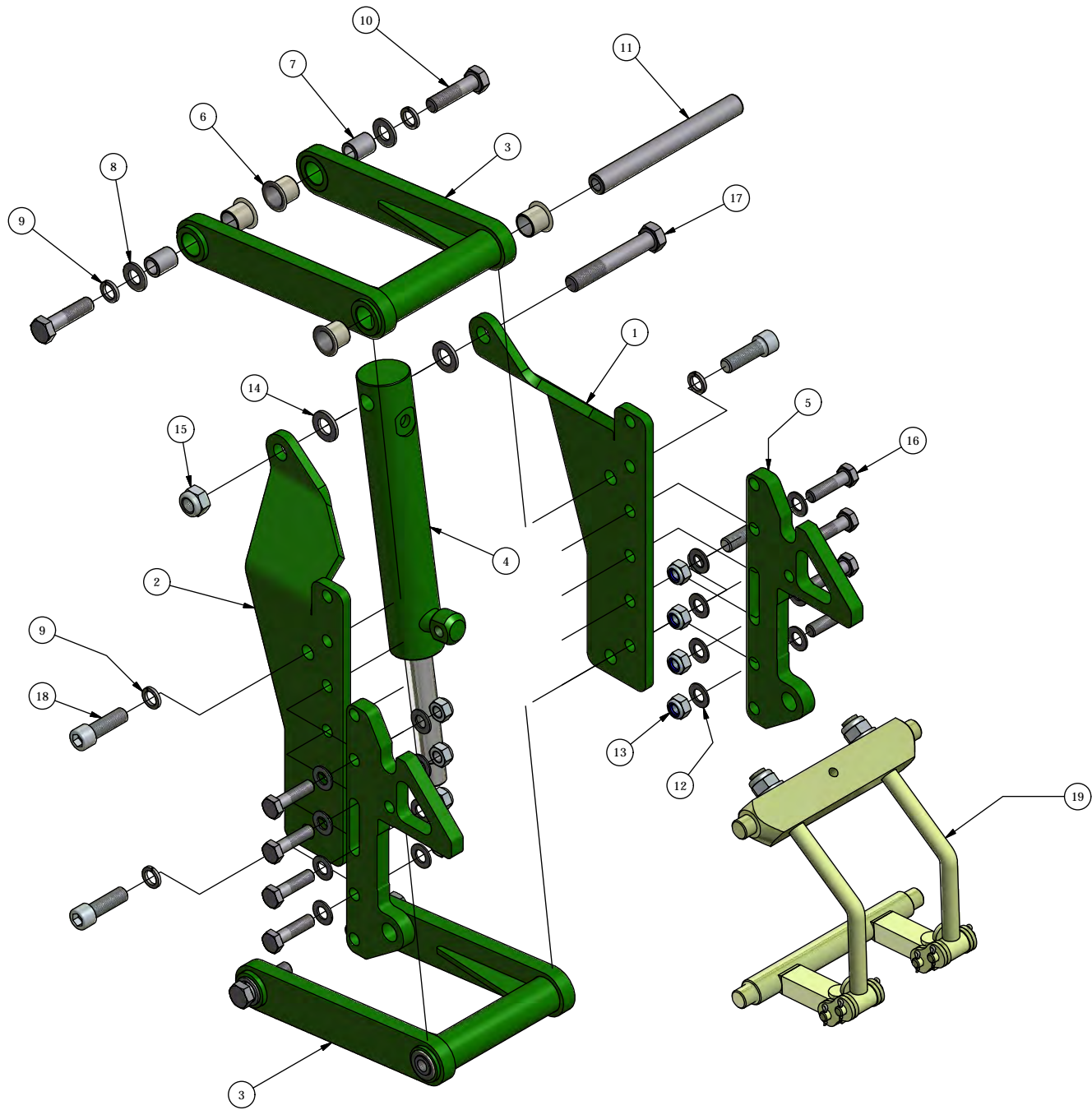

ROBOCROP DISK STEER ASSEMBLY

ITEM No.	DESCRIPTION	PART No.	QUANTITY
1	LH STEER BRACKET	8589.00	1
2	RH STEER BRACKET	8590.00	1
3	PARALLEL STEER LINK	8591.00	2
4	HYDRAULIC ACTUATOR	8596.00	1
5	STEER MOUNT BRACKET	10808.01	2
6	BUSH	8185.02	8
7	STEER BUSH	8598.00	4
8	M14 FLAT WASHER BZP	8994	4
9	M14 SPRING WASHER BZP	8604	8
10	M14x55 BOLT BZP	8603	4
11	STEER BUSH SHAFT	8597.00	2
12	M12 THIN WASHER BZP	7877	16
13	M12 NYLOC NUT BZP	1017	8
14	M16 FLAT WASHER BZP	7878	2
15	M16 NYLOC NUT BZP	1030	1
16	M12x45 BOLT BZP	1016	8
17	M16x100 BOLT BZP	5667	1
18	SOCKET CAP SCREW M14x45 BZP		4
19	FRAME MOUNT BRACKET		1

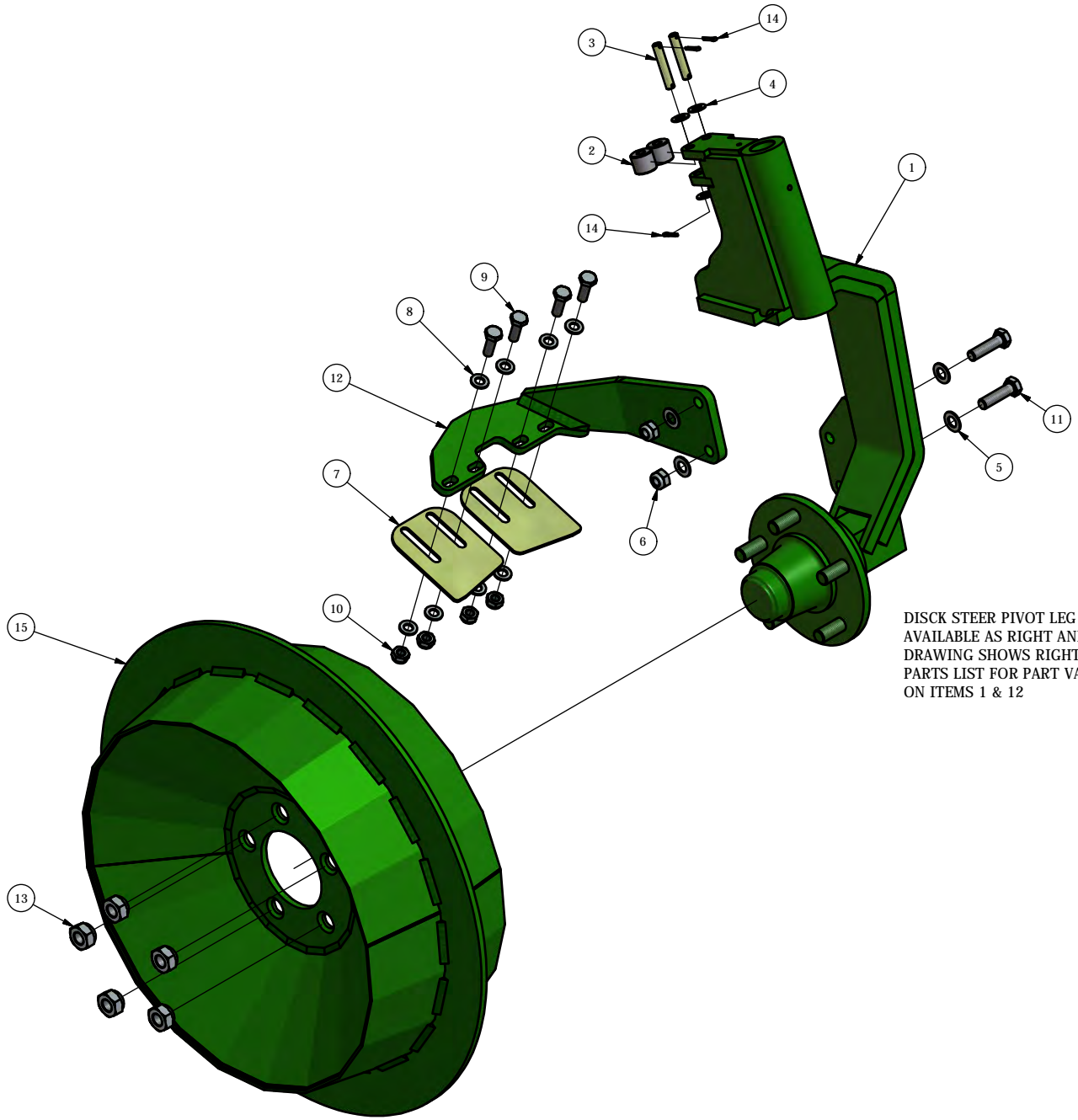

DISCK STEER PIVOT LEG ASSEMBLY
AVAILABLE AS RIGHT AND LEFT HAND.
DRAWING SHOWS RIGHT HAND, SEE
PARTS LIST FOR PART VARIATIONS
ON ITEMS 1 & 12

ROBOCROP DISK STEER WHEEL ASSEMBLY

ITEM No.	DESCRIPTION	PART No.	QUANTITY
1	PIVOT LEG ASSEMBLY RIGHT HAND	9417.00	1
	PIVOT LEG ASSEMBLY LEFT HAND	9416.00	1
2	RAM ROLLER	8688.00	2
3	RAM ROLLER PINS	7726.00	2
4	M10 THIN WASHER BZP	7876	4
5	M12 THIN WASHER BZP	7877	4
6	M12 NYLOC NUT BZP	1017	2
7	WHEEL SCRAPER	9377.00	2
8	M10 FLAT WASHER BZP	1186	8
9	M10x30 BOLT BZP	5668	4
10	M10 NYLOC NUT BZP	1024	4
11	M12x45 BOLT BZP	1016	2
12	SCRAPER ARM RIGHT HAND	9420.00	1
	SCRAPER ARM LEFT HAND	9421.00	1
13	M16 CAPTIVE WHEEL NUT	9422.00	5
14	SPILT PIN	7727.00	4
15	DISK STEER WHEEL	9415.00	1

ENLARGED VIEW AT 'A'

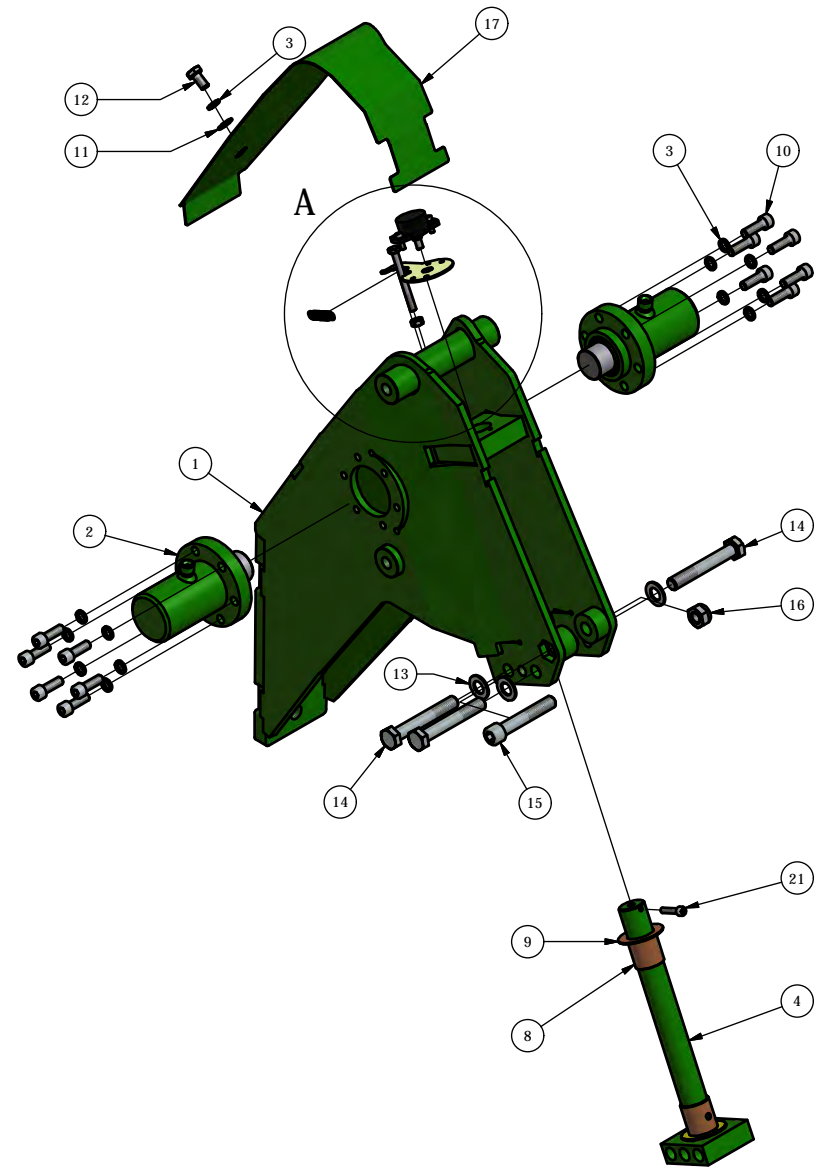
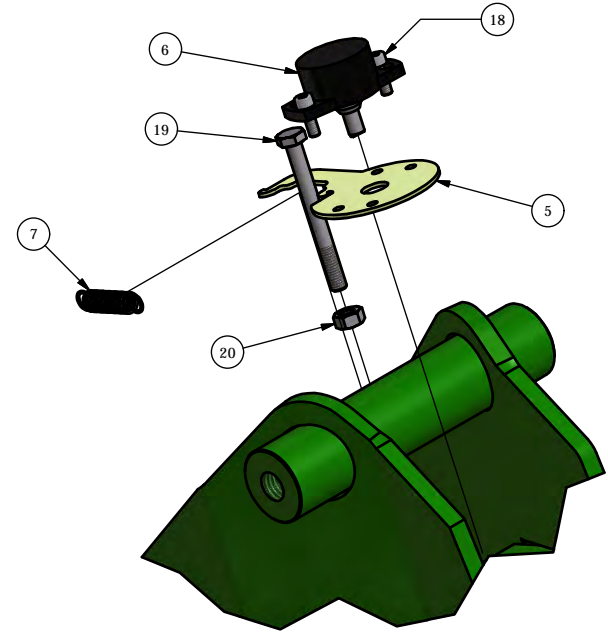

ROBOCROP DISK STEER MECHANISM

ITEM No.	DESCRIPTION	PART No.	QUANTITY
1	DISK STEER WHEEL FRAME	9722.00	1
2	HYDRAULIC STEERING RAM	8668.00	2
3	M8 SPRING WASHER BZP	1154	13
4	PIVOT PIN	8594.00	1
5	POTENTIOMETER MOUNTING PLATE	8675.00	1
6	ROTARY POTENTIOMETER	8674.00	1
7	TENSION SPRING	8676.00	1
8	BUSH	7446.00	2
9	THRUST WASER	8626.00	2
10	SOCKET CAP SCREW M8x25 BZP	6707	12
11	M8 THIN WASHER BZP	1157	1
12	M8x15 BOLT BZP	1156	1
13	M12 THIN WASHER	7877	3
14	M12x80 BOLT BZP	6371	3
15	SOCKET CAP SCREW M12x70 BZP	8827	1
16	M12 NYLOC NUT BZP	1017	1
17	STEERING GUARD	9723.01	1
18	M4x12 SOCKET CAP SCREW BZP		2
19	M6x60 BOLT BZP	8822	1
20	M6 NUT BZP	7712	1
21	SOCKET CAP SCREW M5x25 BZP	5705	1

ENLARGED VIEW AT 'A'

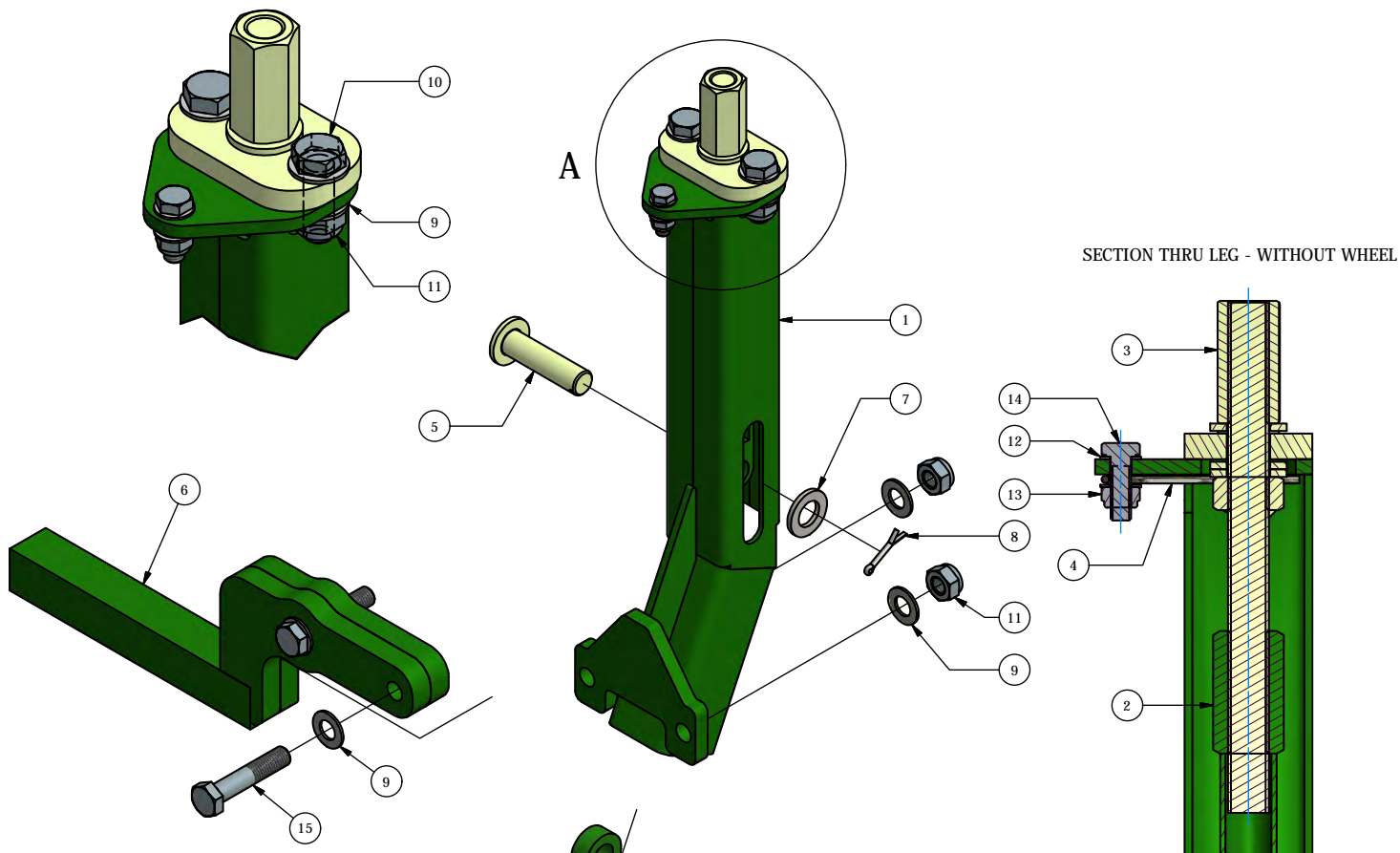

SEE PAGE ON ADJUSTABLE WHEEL LEGS FOR DETAILS OF WHEEL LEG & WHEELS.

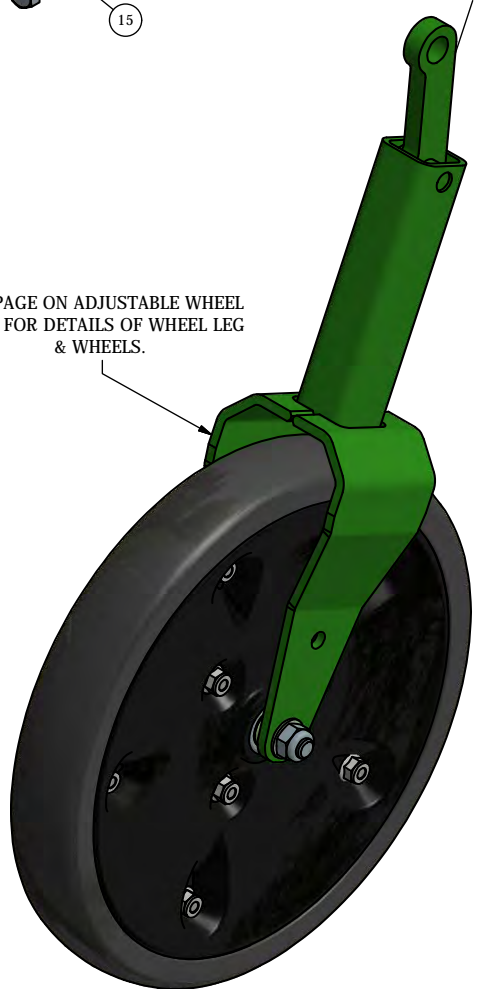

ROBOCROP ADJUSTABLE DEPTH INROW WHEEL LEG

ITEM No.	DESCRIPTION	PART No.	QUANTITY
1	WHEEL LEG	9543.01	1
2	WHEEL ADJSUTER NUT	9024.00	1
3	WHEEL ADJUSTER SCREW	9023.00	1
4	ANTIROTATION SPRING	9029.00	1
5	PIN	9545.00	1
6	WHEEL LEG BRACKET	9544.00	1
7	M16 FLAT WASHER BZP		1
8	SPLIT PIN		1
9	M12 THIN FLAT WASHER BZP	7877	8
10	M12x35 BOLT BZP		2
11	M12 NYLOC NUT BZP	1017	4
12	M8 FLAT THIN WASHER BZP		2
13	M8 NYLOC NUT BZP		1
14	M8x25 BOLT BZP		1
15	M12x60 BOLT BZP		2

50MM ADJUSTABLE WHEEL LEG ASSEMBLY

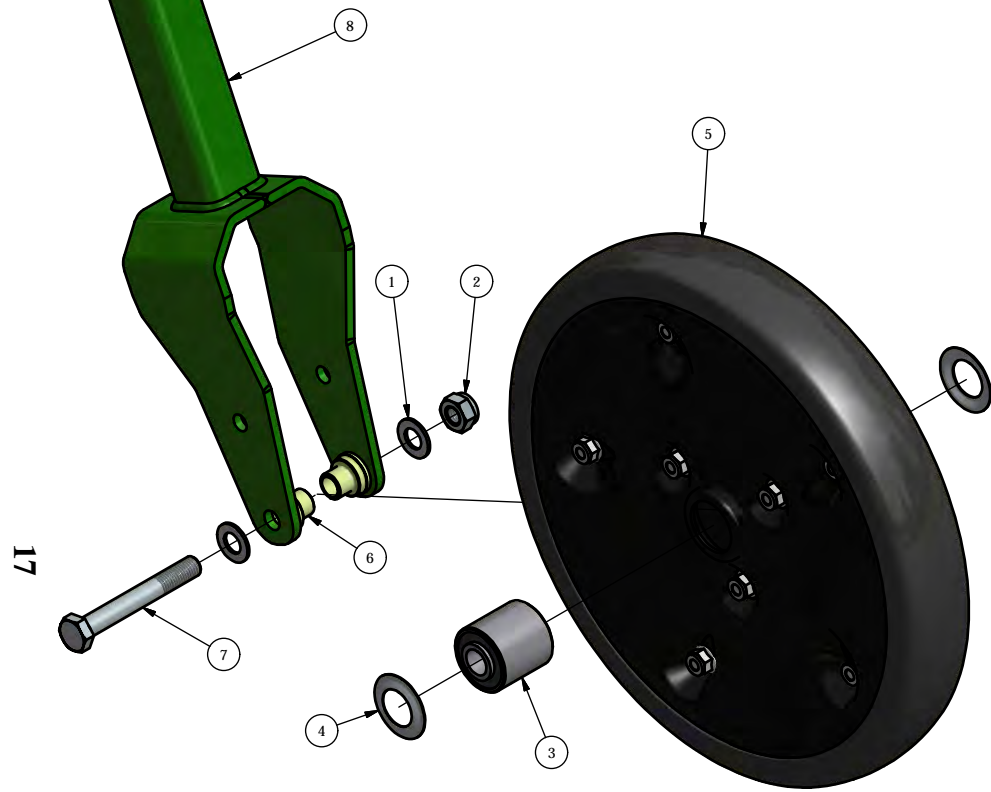

100MM ADJUSTABLE WHEEL LEG ASSEMBLY

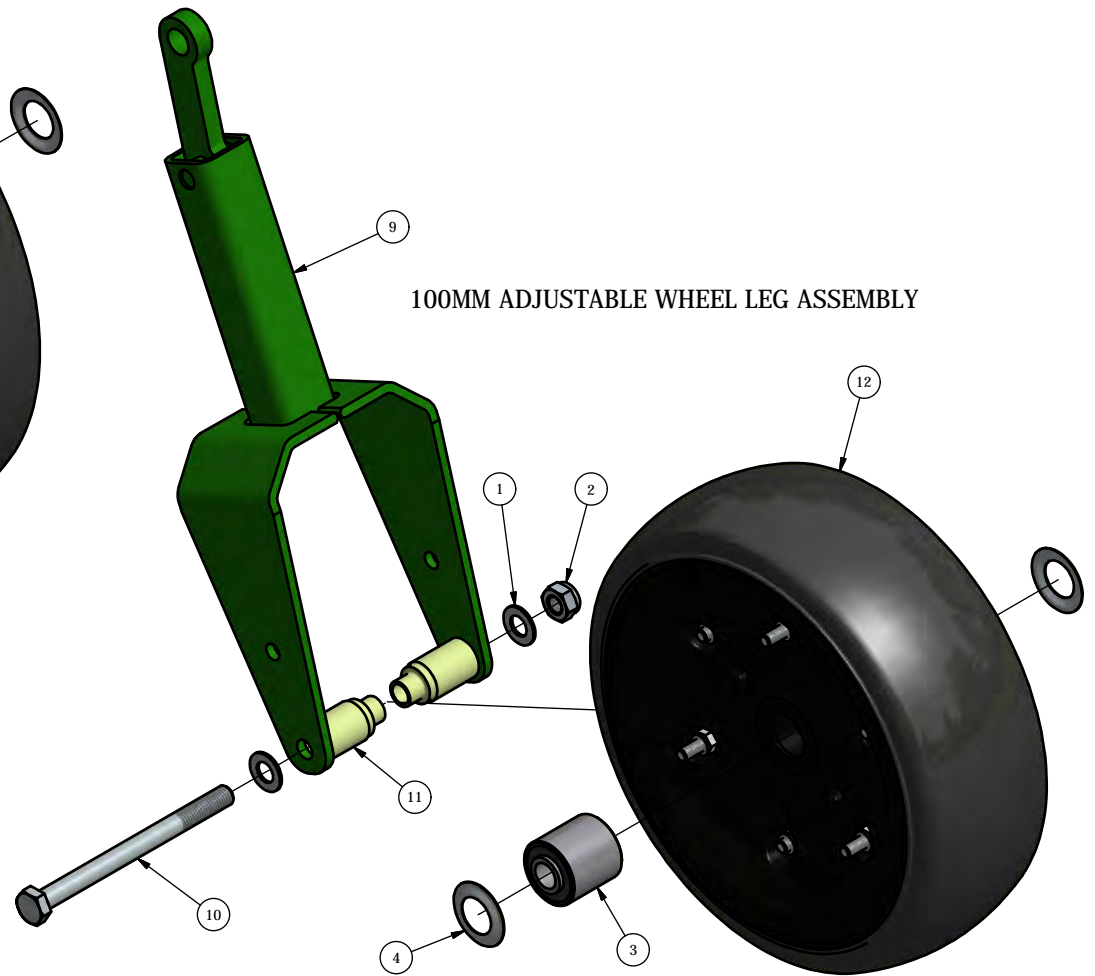

ROBOCROP ADJUSTABLE WHEEL LEGS 50MM & 100MM

ITEM No.	DESCRIPTION	PART No.	QUANTITY
1	M12 THIN WASHER BZP	7877	2
2	M12 NYLOC NUT	1017	1
3	WHEEL BEARING	9511.00	1
4	BEARING SHIELDS	9733.00	2
5	50MM WHEEL	9708.00	1
6	WHEEL SPACER	9733.00	2
7	M12x90 BOLT BZP	1178.00	1
8	50MM WHEEL LEG ASS'Y	9732.00	1
9	100MM WHEEL LEG ASS'Y	9734.00	1
10	M12x150 BOLT BZP	6395	1
11	WHEEL SPACER	9749.00	2
12	100MM WHEEL	9731.00	1

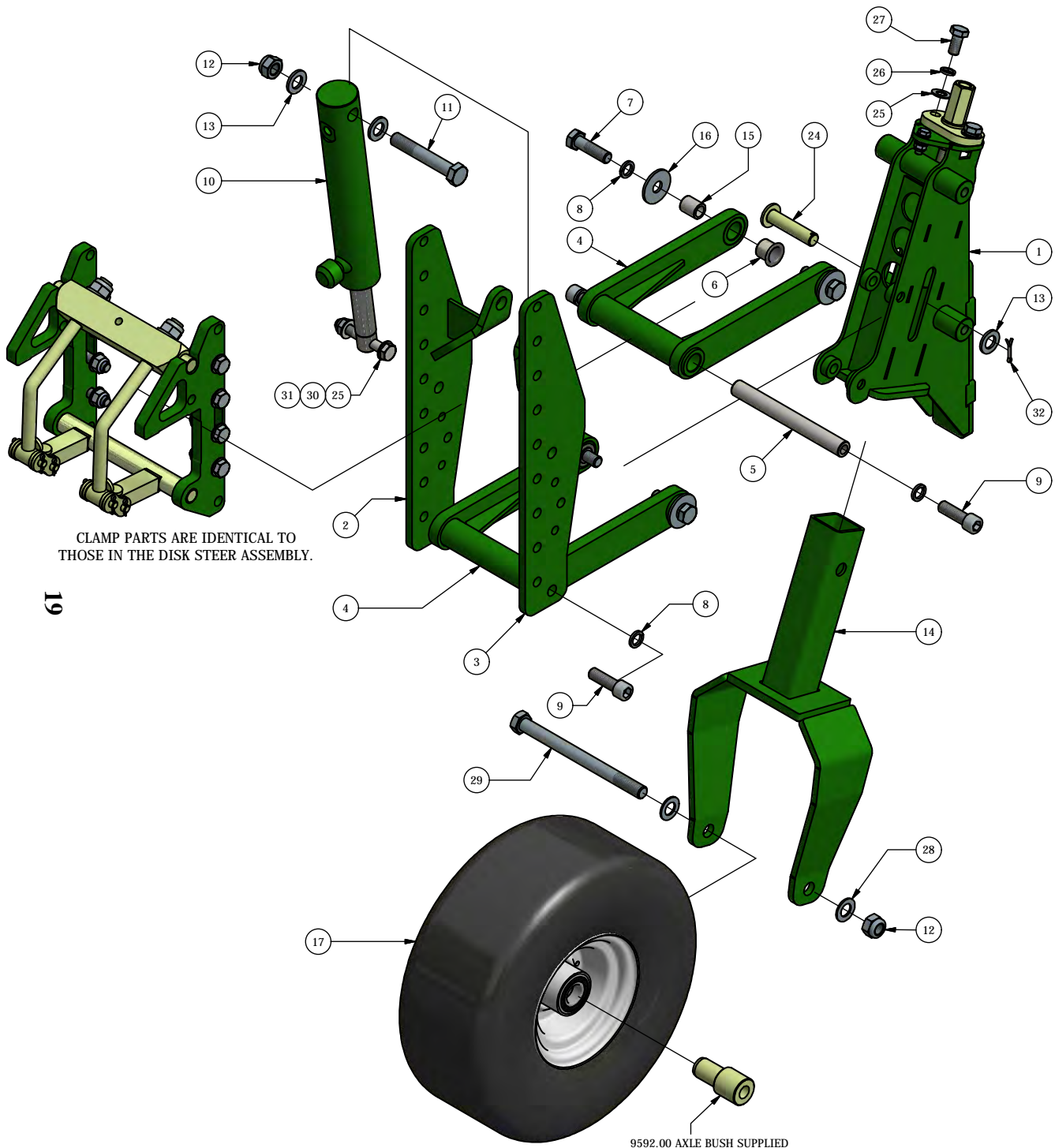

CLAMP PARTS ARE IDENTICAL TO THOSE IN THE DISK STEER ASSEMBLY.

19

9592.00 AXLE BUSH SUPPLIED AS PART OF THE WHEEL ASSEMBLY.

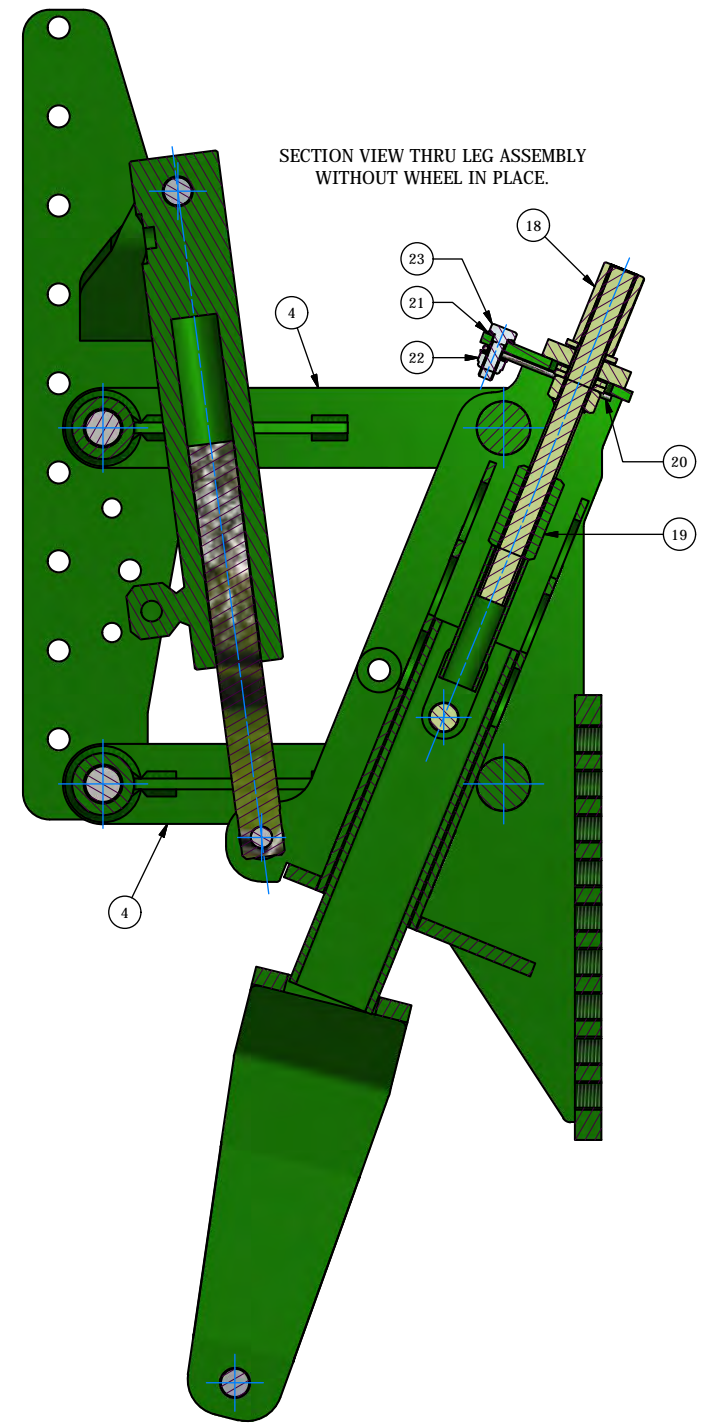

SECTION VIEW THRU LEG ASSEMBLY WITHOUT WHEEL IN PLACE.

ROBOCROP HEAVY DUTY ADJUSTABLE WHEEL LEG

ITEM No.	DESCRIPTION	PART No.	QUANTITY
1	HEAVY DUTY WHEEL FRAME	9570.01	1
2	L/H ADJUSTABLE MOUNTING BRACKET	9710.00	1
3	R/H ADJUSTABLE MOUNTING BRACKET	9711.00	1
4	PARALLEL STEER LINK	8591.00	2
5	STEER BUSH SHAFT	8597.00	2
6	BUSH	8185.02	8
7	M14x55 BOLT BZP	8603	4
8	M14 SPRING WASHER BZP	8604	8
9	M14x45 SOCKET CAP SCREW BZP		4
10	HYDRAULIC RAM	8596.00	1
11	M16x100 BOLT BZP	5667	1
12	M16 NYLOC NUT BZP	1030	2
13	M1 FLAT WASHER BZP	7878	3
14	WHEEL LEG	9571.00	1
15	STEER BUSH	8598.00	4
16	M14 LARGE OD WASHER BZP		4
17	WHEEL ASSEMBLY	9591.00 – 9592.00 as	1
18	WHEEL ADJSUTER SCREW	9023.00	1
19	WHEEL ADJUSTER NUT	9024.00	1
20	ANTIROTATION SPRING	9029.00	1
21	M8 THIN WASHER BZP		2
22	M8 NYLOC NUT BZP		1
23	M8x25 BOLT BZP		1
24	PIN	9572.00	1
25	M12 THIN WASHER BZP	7877	4
26	M12 SPRING WASHER BZP		2
27	M12x25 BOLT BZP		2
28	M16 THIN WASHER BZP		2
29	M16x200 BOLT BZP		1
30	M12 NYLOC NUT BZP	1017	1
31	M12x80 BOLT BZP		1
32	SPLIT PIN		1

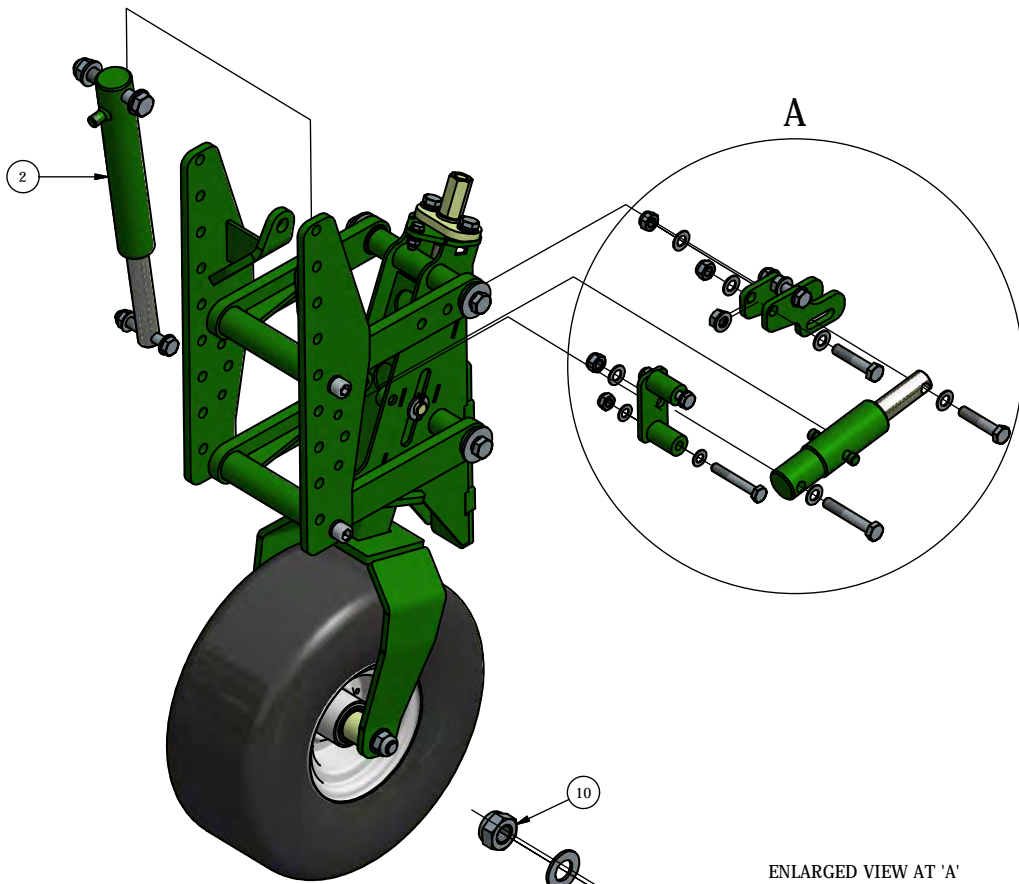
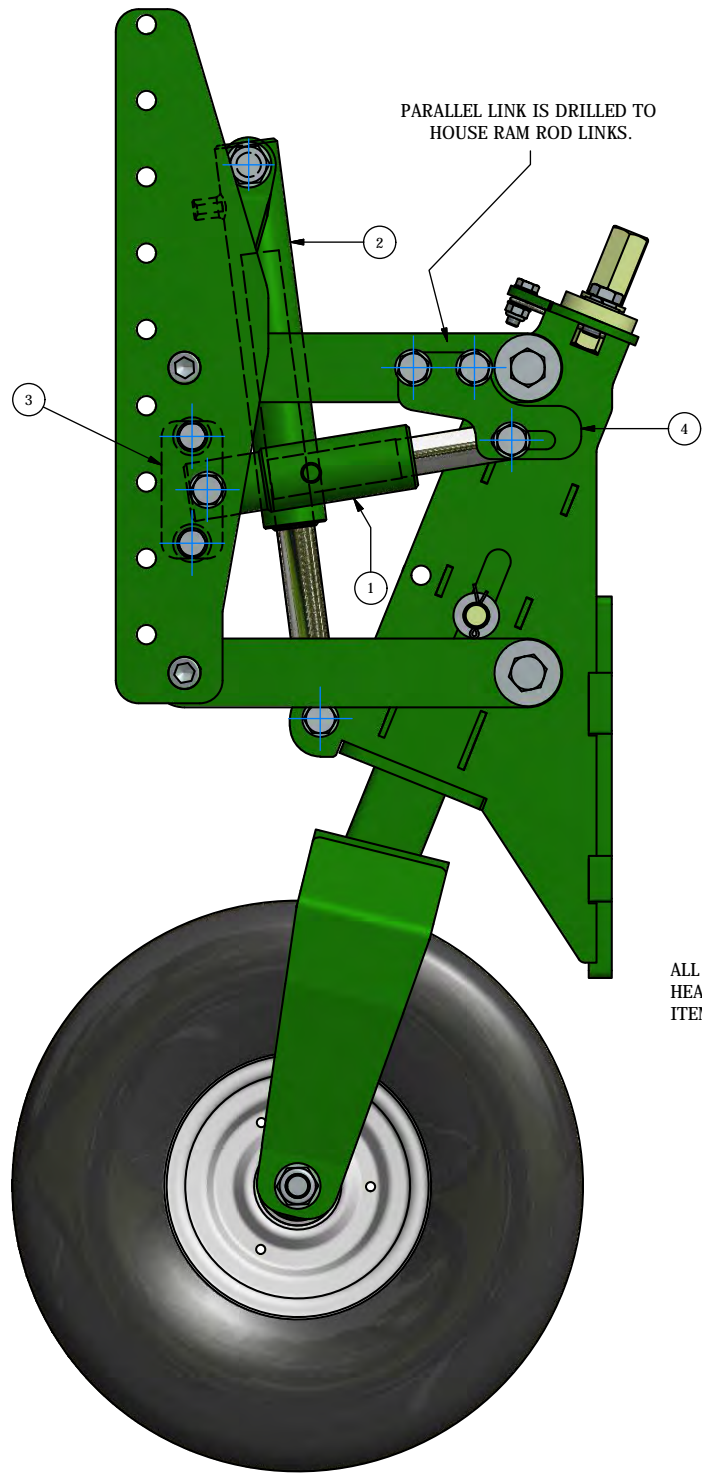

ALL PARTS ARE IDENTICAL TO THAT OF THE HEAVY DUTY WHEEL LEG, WITH THE FOLLOWING ITEMS SHOWN.

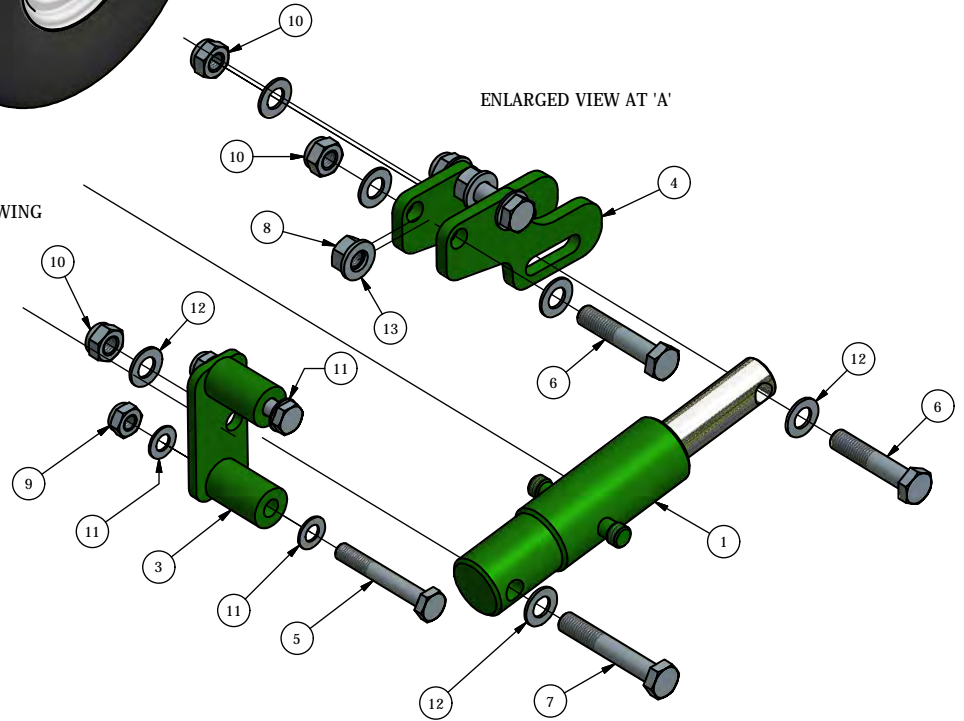

ROBOCROP HEAVY DUTY ADJUSTABLE WHEEL LEG
WITH RETRACTING RAM

ITEM No.	DESCRIPTION	PART No.	QUANTITY
1	HYDRAULIC RAM	7330.00	1
2	HYDRAULIC RAM	9596.00	1
3	RAM BRACKET	9713.00	1
4	RAM – ROD LINK	9714.00	1
5	M10x70 BOLT BZP		2
6	M12x60 BOLT BZP		3
7	M12x75 BOLT BZP		1
8	M12 NUT BZP		2
9	M10 NYLOC NUT BZP		2
10	M12 NYLOC NUT BZP	1017	4
11	M10 THIN WASHER BZP		4
12	M12 THIN WASHER BZP	7877	7
13	M12 FLAT WASHER BZP		2

SECTIONAL VIEW THRU ENCODER.

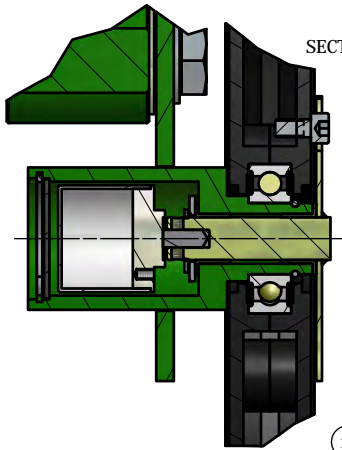

23

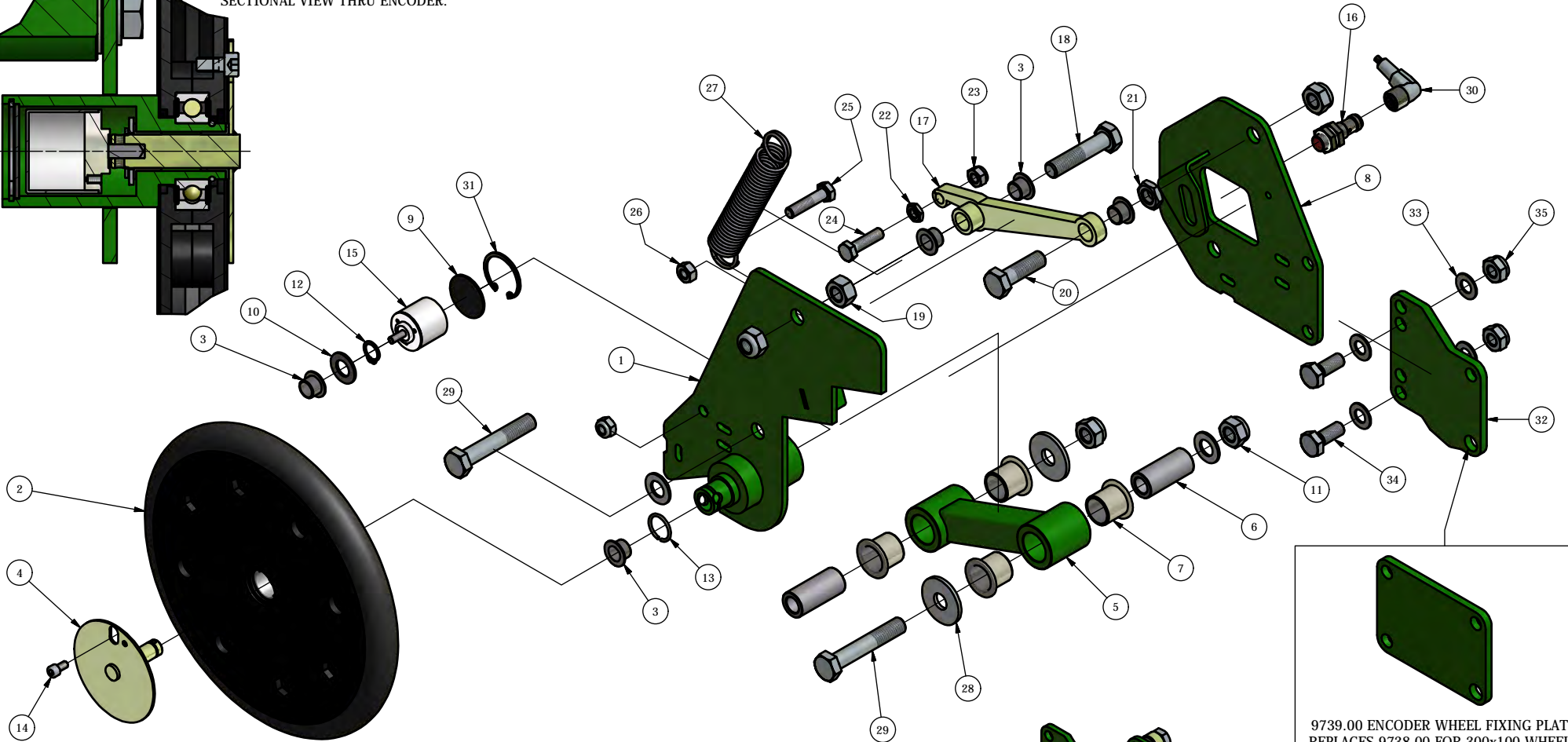

9739.00 ENCODER WHEEL FIXING PLATE,
REPLACES 9738.00 FOR 300x100 WHEELS.

ASSEMBLED VIEWS FROM FRONT & REAR.



ROBOCROP ENCODER WHEEL ASSEMBLY

ITEM No.	DESCRIPTION	PART No.	QUANTITY
1	ENCODER WHEEL MOUNT / AXEL BRACKET	9385.00	1
2	ENCODER WHEEL WITH BEARING	9034.00	1
3	BUSH	9036.00	5
4	ENCODER WHEEL DRIVE	9039.00	1
5	PARALLEL LINK	8645.00	1
6	PARALLEL LINK AXEL	8646.00	2
7	BUSH	8185.02	4
8	PARALLEL LINK MOUNT	9737.00	1
9	ENCODER WHEEL CAP	9043.00	1
10	M12 THIN WASHER BZP	7877	3
11	M12 NYLOC NUT BZP	1017	4
12	13MM EXTERNAL CIRCLIP		1
13	SNAP RING		1
14	M5x10 SOCKET CAP SCREW BZP	8682	1
15	ENCODER	9347.00	1
16	NPN PROXIMITY SENSOR	10121.00	1
17	PARALLEL LINK	9397.00	1
18	M12x55 BOLT BZP	6696	1
19	M12 NUT BZP	1019	1
20	M12x40 BOLT BZP	1159	1
21	M12 HALF NUT BZP	5833	1
22	M8 HALF NUT BZP		1
23	M8 NYLOC NUT BZP	1042	2
24	M8x30 BOLT BZP	1153	1
25	M8x35 BOLT BZP	7463	1
26	M8 NUT BZP	1185	1
27	DOUBLE LOOP TENSION SPRING	6595.00	1
28	LARGE OD FLAT WASHER 12x37x3 BZP		2
29	M12x70 BOLT BZP	5666	2
30	PROXIMITY CABLE WITH 90° PLUG 5M	10122.00	1
31	34MM INTERNAL CIRCLIP	9097	1
32	ENCODER WHEEL FIXING PLATE	9738.00	1
33	M10 THIN WASHER BZP	7876	4
34	M10x25 BOLT BZP	1120	2
35	M10 NYLOC NUT BZP	1024	2

SECTION THRU WHEEL SHAFT.

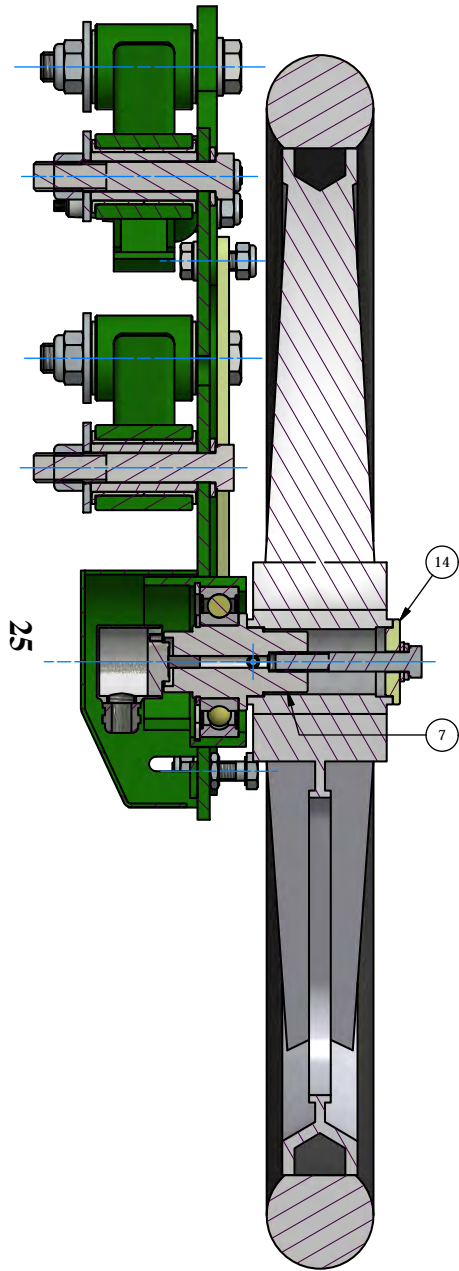

REAR VIEW SHOWING LOCK UP CATCH IN PLACE - LOCKED POSITION

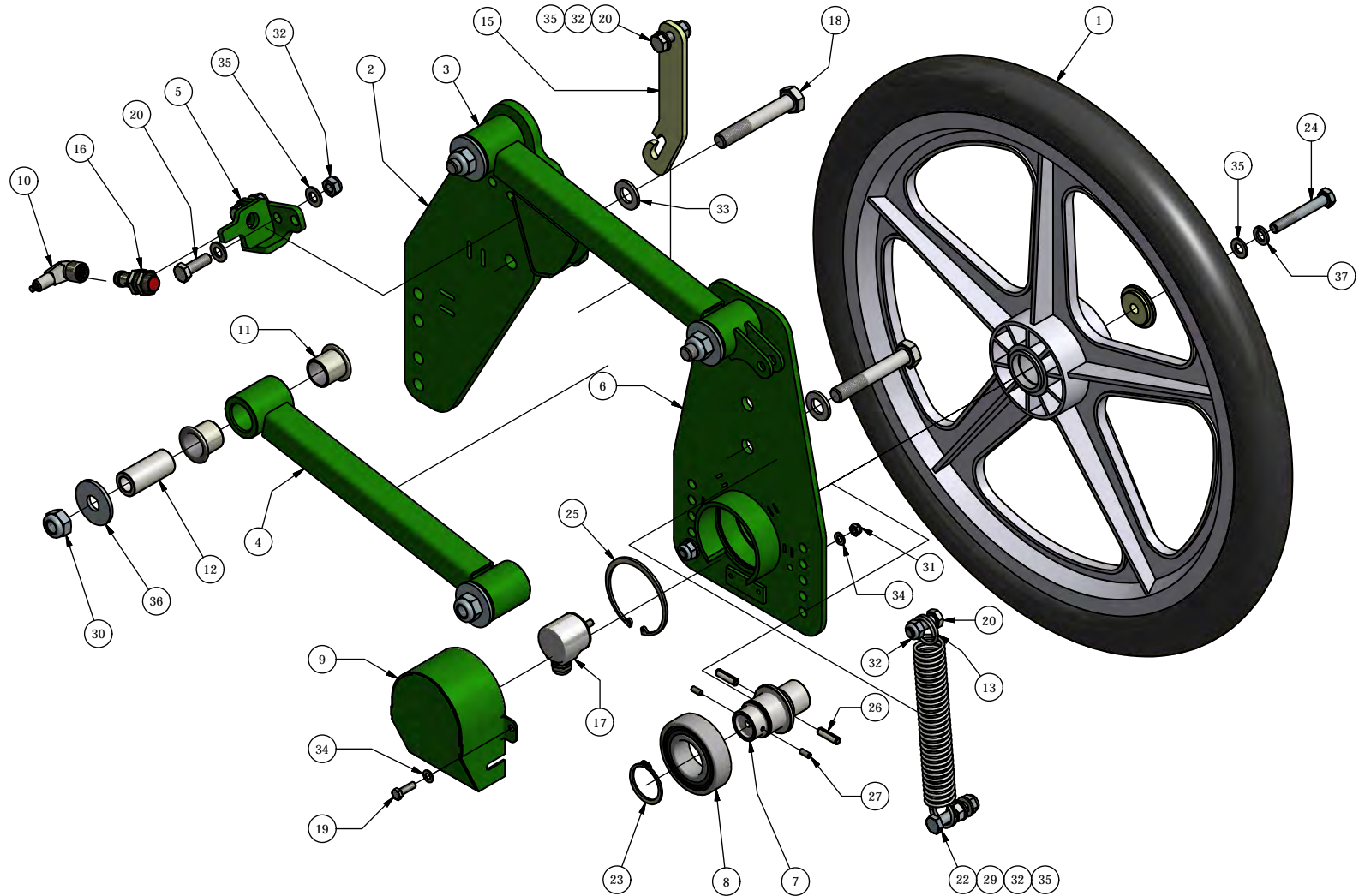
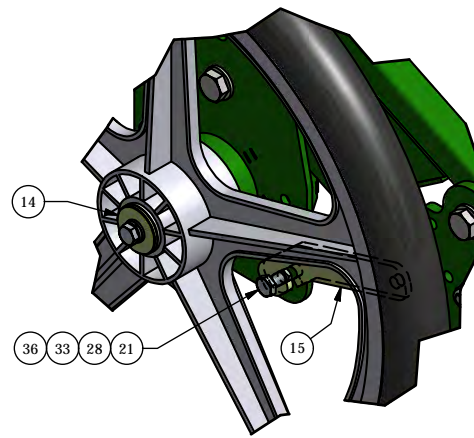

ROBOCROP LARGE ENCODER WHEEL ASSEMBLY

ITEM No.	DESCRIPTION	PART No.	QUANTITY
1	ENCODER WHEEL	8647.01	1
2	MOUNT BRACKET FOR ENCODER WHEEL	9991.00	1
3	UPPER PARALLEL LINK	9857.00	1
4	LOWER PARALLEL LINK	9858.00	1
5	LIFT SENSOR BRACKET	9856.01	1
6	BEARING HOUSING	9859.00	1
7	ENCODER WHEEL SHAFT	9860.01	1
8	SEALED BEARING 6206-2RS1		1
9	ENCODER WHEEL GUARD	9862.00	1
10	PROXIMITY CABLE WITH 90° PLUG 5M	10122.00	1
11	BUSH	8185.02	8
12	AXLE FOR PARALLEL LINKS	8646.00	4
13	SPRING	6595.00	1
14	ENCODER WHEEL CAP	9861.01	1
15	LOCK UP CATCH	9864.00	1
16	NPN PROXIMITY SENSOR	10121.00	1
17	ENCODER	9347.00	1
18	M12x75 BOLT BZP		4
19	M5x16 BOLT BZP		2
20	M8x25 BOLT BZP		4
21	M8x30 BOLT BZP		1
22	M8x40 BOLT BZP		1
23	30MM EXTERNAL CIRCLIP		1
24	M8x55 BOLT		1
25	62MM INTERNAL CIRCLIP		1
26	5MM SPRING PIN		2
27	M4x10 SET SCREW BZP		2
28	M8 HALF NUT BZP		1
29	M8 NUT BZP		1
30	M12 NYLOC NUT BZP		4
31	M5 NYLOC NUT BZP		2
32	M8 NYLOC NUT BZP		6
33	M12 WASHER BZP		4
34	M5 WASHER BZP		4
35	M8 WASHER BZP		9
36	M12x37ODx3 LARGE OD WASHER BZP		4
37	M8 SPRING WASHER BZP		1

DISK STEER FRAME MOUNT
BRACKET 100mm x 50mm BOX SECTION.

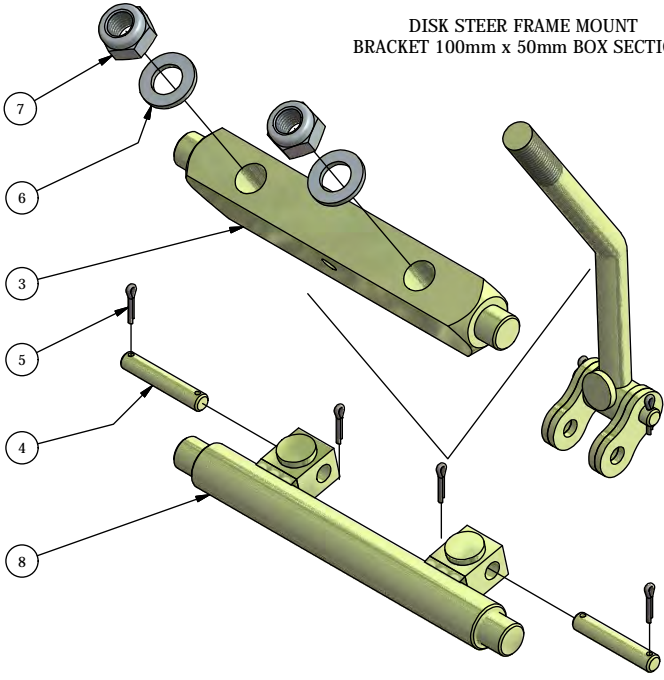

DISK STEER FRAME MOUNT
BRACKET, ASSEMBLED VIEW.

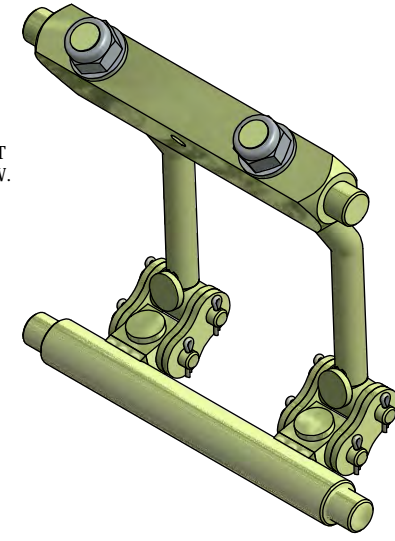

27

DISK STEER FRAME MOUNT
BRACKET 100mm x 100mm BOX SECTION.

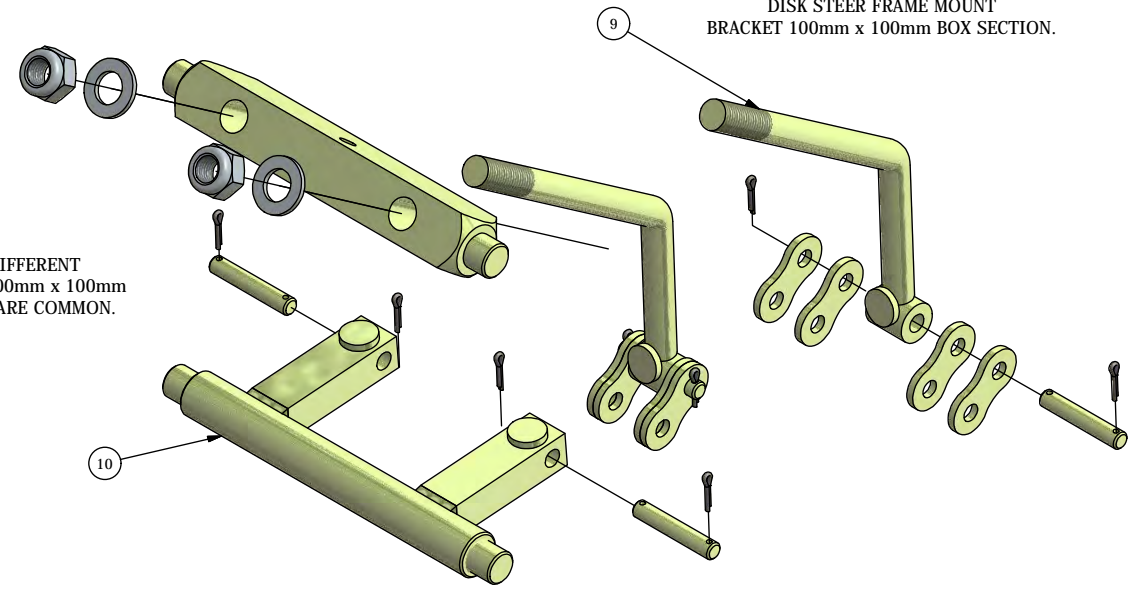

ITEMS 9 & 10 ARE THE DIFFERENT
PARTS REQUIRED FOR 100mm x 100mm
BOX. ALL OTHER PARTS ARE COMMON.

DISK STEER FRAME MOUNT
BRACKET, ASSEMBLED VIEW.

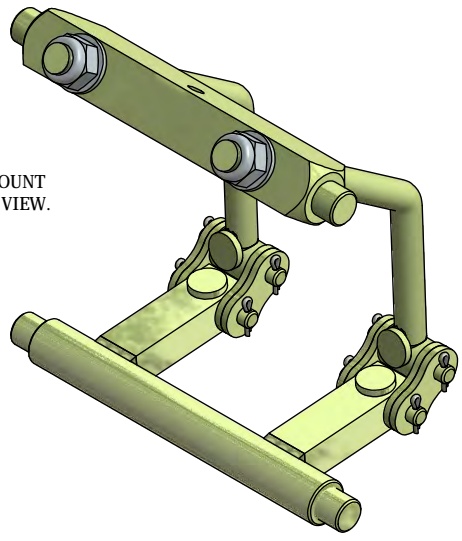

ROBOCROP DISK STEER FRAME MOUNT BRACKET

ITEM No.	DESCRIPTION	PART No.	QUANTITY
1	CHAIN LINK PLATE	7725.00	8
2	CLAMP BOLT (100x50 BOX)	7538.00	2
3	BOLT SWIVEL	10834.00	1
4	LINK PIN	7726.00	4
5	LINK SPLIT PIN	7727.00	8
6	M16 THIN WASHER BZP	1035	2
7	M16 NYLOC NUT BZP	1030	2
8	CLAMP LINK (100x50 BOX)	8600.01	1
9	CLAMP BOLT (100x100 BOX)	7536.00	2
10	CLAMP LINK (100x100 BOX)	8601.01	1

FRAME CLAMP ASSEMBLY
TO SUIT 100mm x 50mm BOX SECTION.

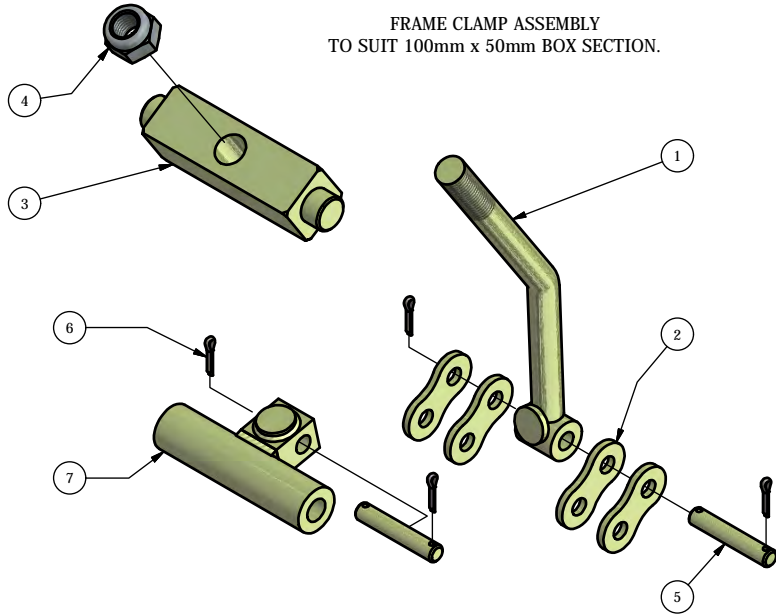

FRAME CLAMP ASSEMBLY
ASSEMBLED VIEW.

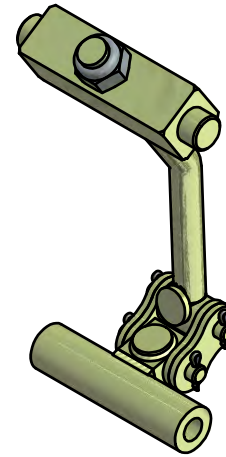

FRAME CLAMP ASSEMBLY
ASSEMBLED VIEW.

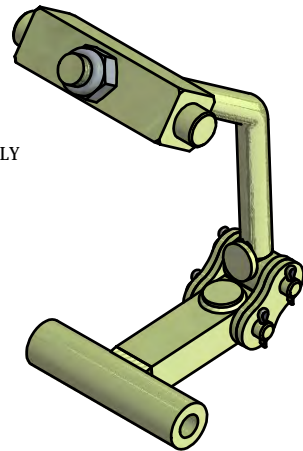

FRAME CLAMP ASSEMBLY
TO SUIT 100mm x 100mm BOX SECTION.

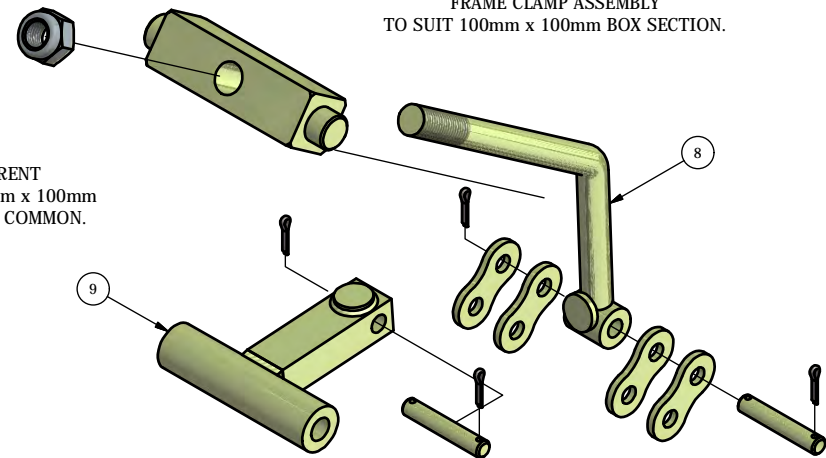

ITEMS 8 & 9 ARE THE DIFFERENT
PARTS REQUIRED FOR 100mm x 100mm
BOX. ALL OTHER PARTS ARE COMMON.

ROBOCROP WHEEL ASSEMBLY FRAME CLAMPS

ITEM No.	DESCRIPTION	PART No.	QUANTITY
1	CLAMP BOLT (100x50 BOX)	7538.00	1
2	CHAIN LINK PLATE	7725.00	4
3	BOLT SWIVEL	7540.00	1
4	M16 NYLOC NUT BZP	1030	1
5	LINK PIN	7726.00	2
6	LINK SPLIT PIN	7727.00	4
7	CLAMP LINK (100x50 BOX)	7539.00	1
8	CLAMP BOLT (100x100 BOX)	7536.00	1
9	CLAMP LINK (100x100 BOX)	7537.00	1

CULTIVATING PARTS SECTION

CONTENTS

	PAGE
ROBOCROP SPRING TINES, 'A' BLADES, SLASH BLADES & WELD ON BLADES	1-2
ROBOCROP COMPACT SPRING TINE ASSEMBLY	3-4
ROBOCROP RIDGING UNIT OPTIONS	5-6
ROBOCROP SPRING TINE 'A' SHARES & RIDGING UNIT	7-8
ROBOCROP IN ROW TINE FRAME ASSEMBLY	9-10
ROBOCROP CROP PROTECTION SHIELDS	11-12
ROBOCROP IN ROW DISC SIZES & DISC LEGS	13-14

<CLICK> TO RETURN TO MAIN SUB SECTION CONTENTS PAGE

SLASH BLADES

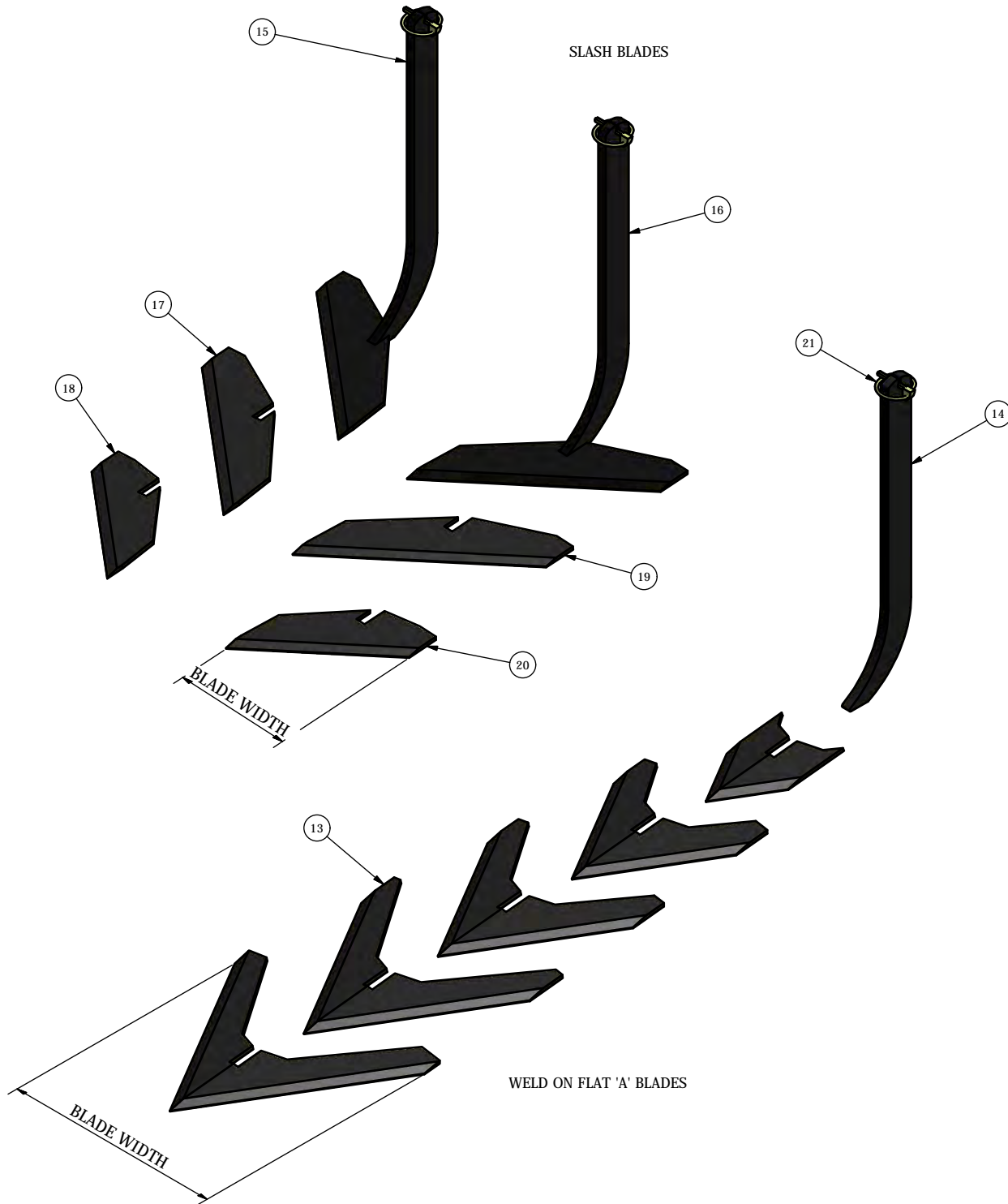

ADJUSTABLE SPRING TINE ASSEMBLY



SPRING TINE & 'A' SHARE ASSEMBLY

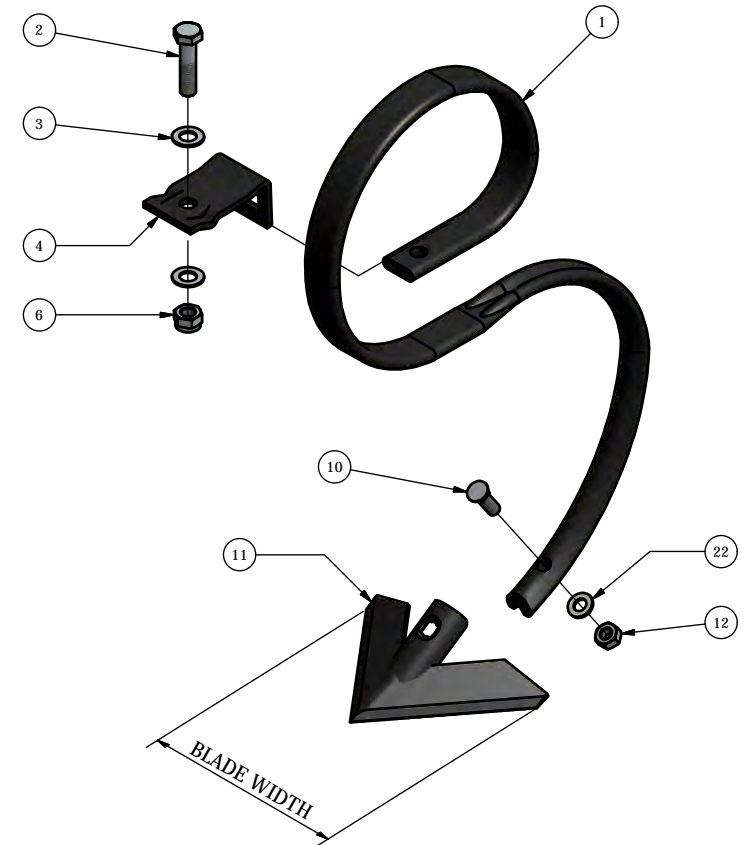

WELD ON FLAT 'A' BLADES

**ROBOCROP SPRING TINES, 'A' BLADES, SLASH BLADES
& WELD ON BLADES**

QUANTITY NOT SHOWN AS LIST IS FOR REFERENCE PURPOSES ONLY

ITEM No.	DESCRIPTION	PART No.	QUANTITY
1	SPRING TINE	5989.00	
2	M12x50 FINE THREAD BOLT BZP	7709	
3	M12 THIN WASHER BZP	7877	
4	SPRING TINE CLAMP	5992.00	
5	ADJUSTABLE SPRING TINE CLAMP	7515.00	
6	M12 FINE THREAD NYLOC NUT BZP	7487	
7	ADJUSTABLE SPRING TINE	7412.00	
8	M12x40 FINE THREAD BOLT BZP	8368	
9	ADJUSTABLE SPRING TINE NUT BLOCK	8365.00	
10	M10 SHARE BOLT	7812	
11	BOLT ON 'A' SHARES		
	100MM WIDE BLADE	6094.00	
	125MM WIDE BLADE	6871.00	
	150MM WIDE BLADE	7831.00	
	180MM WIDE BLADE	5990.00	
	200MM WIDE BLADE	7814.00	
	250MM WIDE BLADE	7815.00	
12	M10 HEX. NUT BZP	1150	
13	WELD ON FLAT 'A' SHARES		
	100MM WIDE BLADE	7648.00	
	120MM WIDE BLADE	7905.00	
	160MM WIDE BLADE	7619.00	
	180MM WIDE BLADE	7768.00	
	200MM WIDE BLADE	7741.00	
	220MM WIDE BLADE	7767.00	
	250MM WIDE BLADE	7551.00	
14	BLADE LEG	7552.00	
15	COMPLETE R/H SLASH BLADE LEG 180MM	7750.00	
	COMPLETE R/H SLASH BLADE LEG 130MM	8093.00	
16	COMPLETE L/H SLASH BLADE LEG 180MM	7749.00	
	COMPLETE L/H SLASH BLADE LEG 130MM	8094.00	
17	WELD ON 180MM R/H SLASH BLADE	7745.00	
18	WELD ON 130MM R/H SLASH BLADE	8091.00	
19	WELD ON 180MM L/H SLASH BLADE	7744.00	
20	WELD ON 130MM L/H SLASH BLADE	8092.00	
21	RETAINING PIN	10557.00	
22	M10 FLAT WASHER BZP		

3

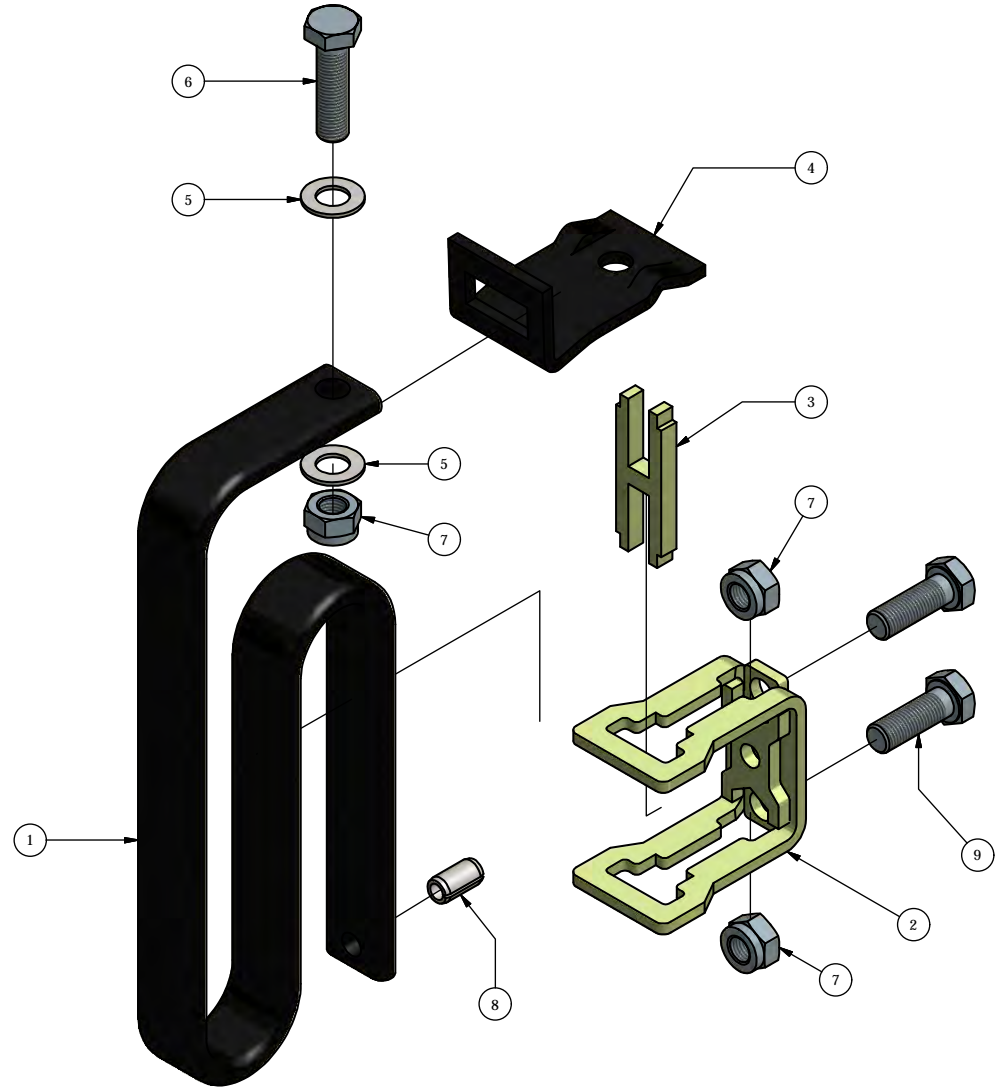
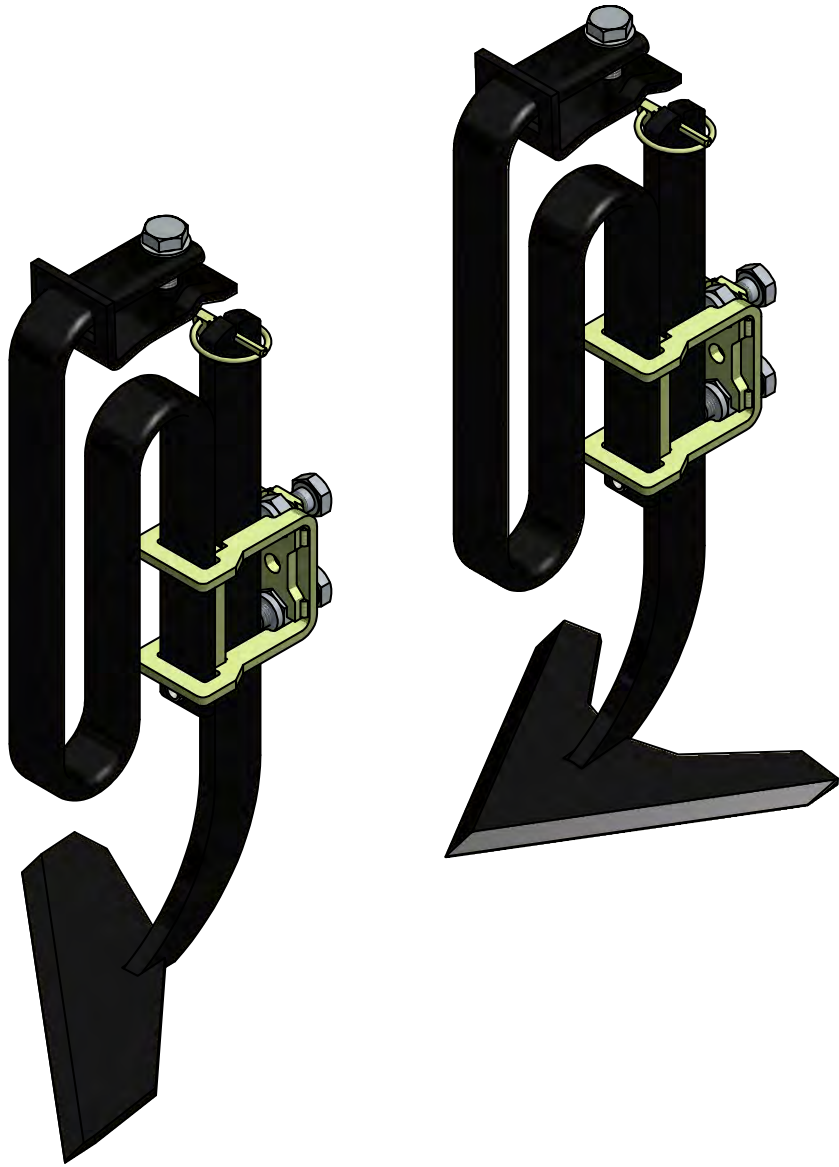

ROBOCROP COMPACT SPRING TINE ASSEMBLY

ITEM No.	DESCRIPTION	PART No.	QUANTITY
1	COMPACT SPRING TINE	9777.01	1
2	TINE CLAMP	10094.00	1
3	TINE CLAMP ROCKER BASE	10095.00	1
4	S-TINE CLAMP	5992	1
5	M12 THIN WASHER BZP		2
6	M12x45 FINE THREAD BOLT BZP		1
7	M12x1.5 NYLOC NUT BZP		3
8	SPRING PIN		1
9	M12x35 FINE THREAD BOLT BZP		2

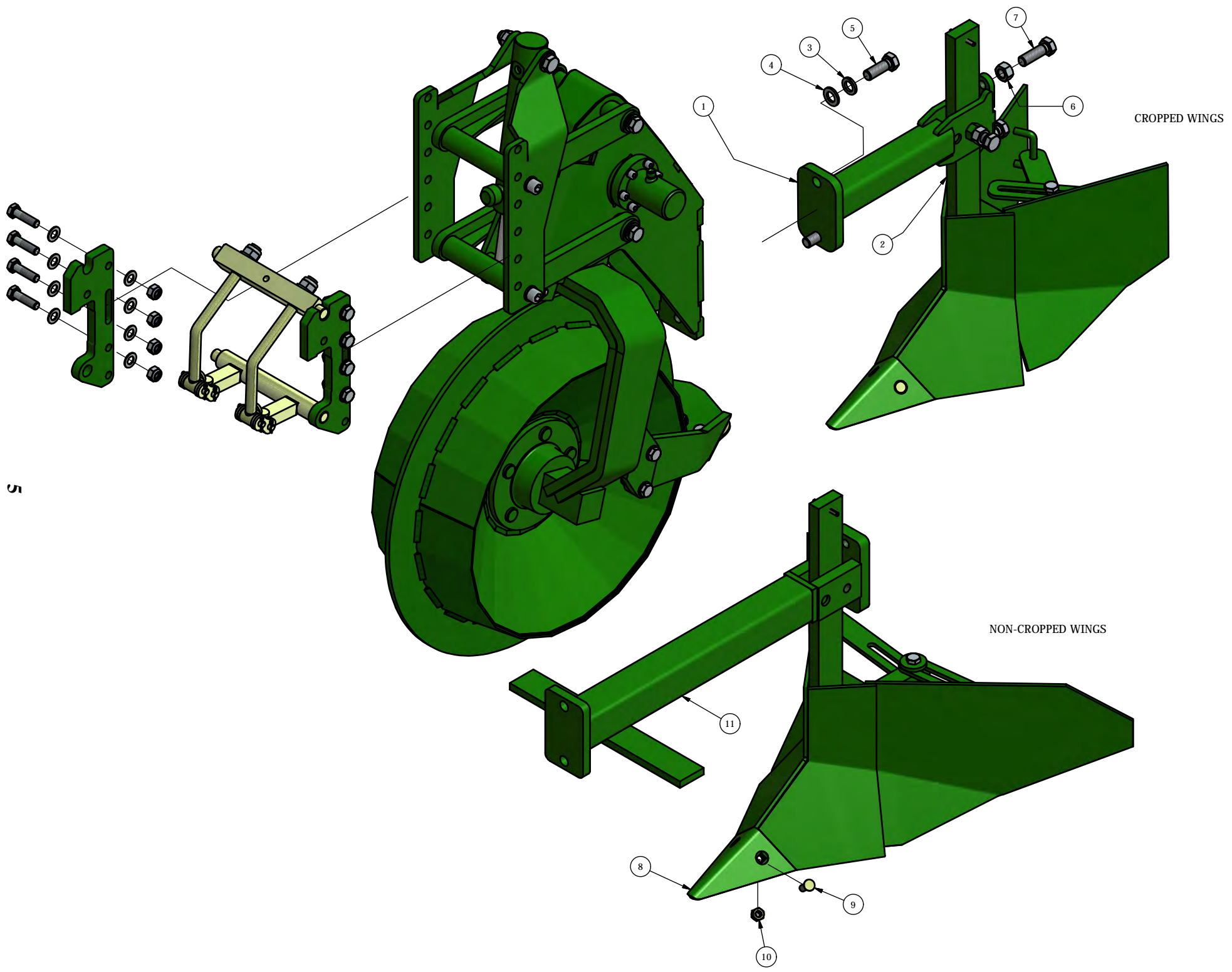

CROPPED WINGS

NON-CROPPED WINGS

5

ROBOCROP RIDGING UNIT OPTIONS

ITEM No.	DESCRIPTION	PART No.	QUANTITY
1	RIDGING BODY FRAME	9373.00	1
2	RIDGING BODY (CROPPED WINGS)	9374.00	1
	RIDGING BODY (NON-CROPPED WINGS)	7467.00	
3	M16 SPRING WASHER BZP	1119	2
4	M16 FLAT WASHER BZP	7878	2
5	M16x45 BOLT BZP	5664	2
6	M16 NUT BZP	1015	3
7	M16x50 BOLT BZP	9126	3
8	RIDGING BODY POINT	7670.00	1
9	M10x25 SHARE BOLT	7812	2
10	M10 HEX NUT	1150	2
11	RIDGING BODY FRAME	7351.00	1

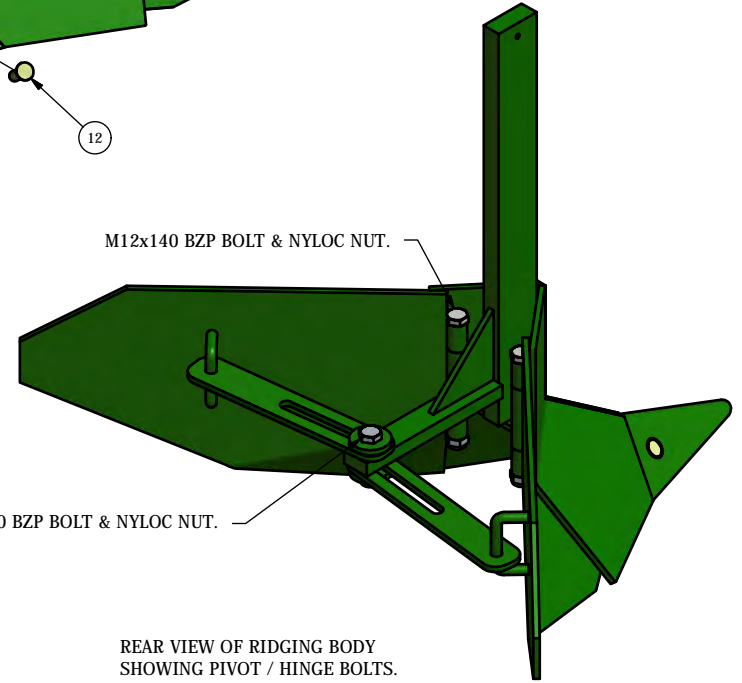
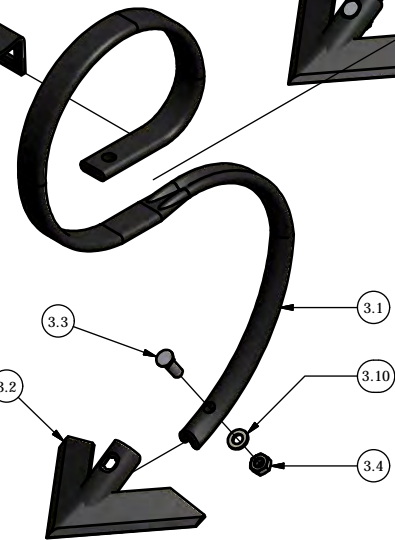
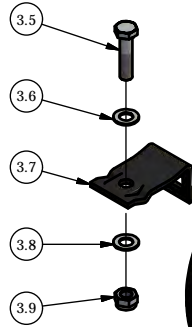
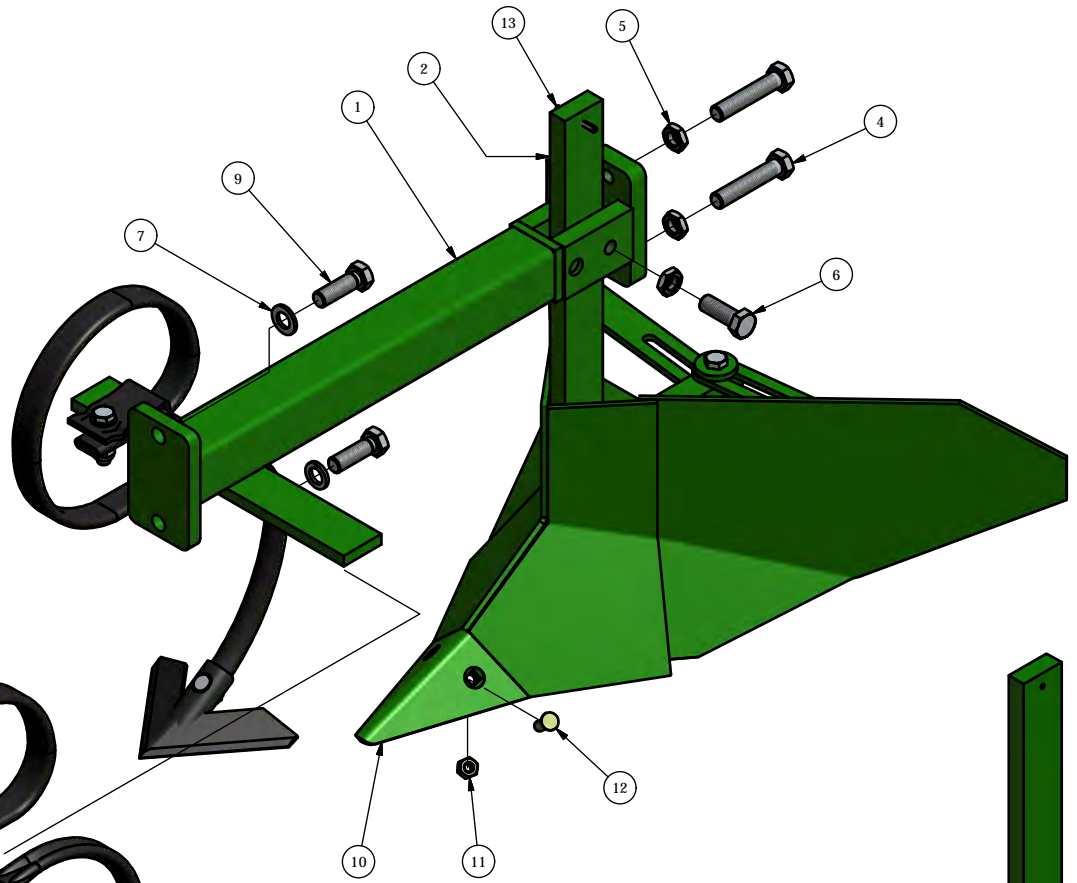
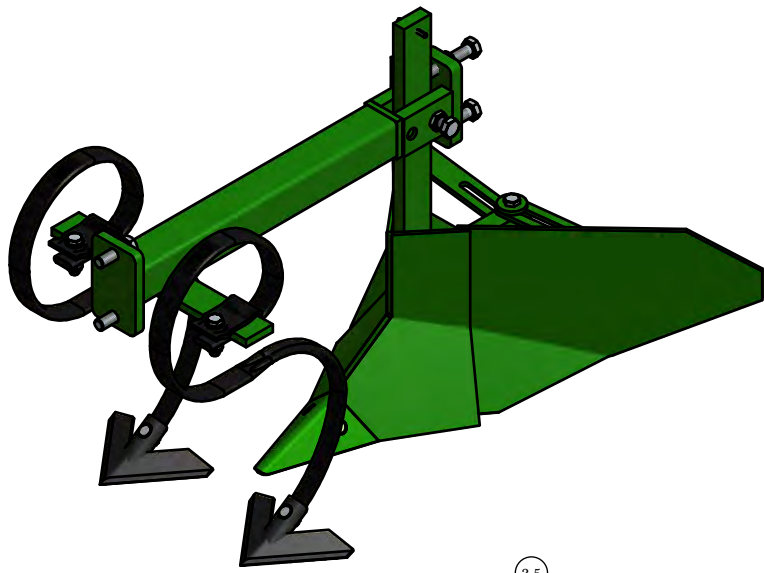

7

SPRING TINE AND A-SHARE ASSEMBLY

A-SHARES ARE AVAILABLE
IN VARIOUS BLADE WIDTHS :-

6094.00	100mm
6871.00	125mm
7813.00	150mm
5990.00	180mm
7814.00	200mm
7815.00	250mm

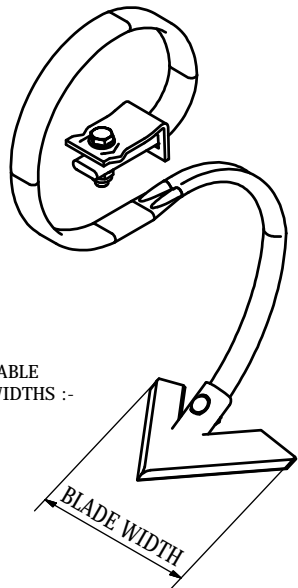

M12x140 BZP BOLT & NYLOC NUT.

M12x50 BZP BOLT & NYLOC NUT.

REAR VIEW OF RIDGING BODY
SHOWING PIVOT / HINGE BOLTS.

ROBOCROP SPRING TINE “A” SHARES
& RIDGING UNIT

ITEM No.	DESCRIPTION	PART No.	QUANTITY
1	RI DGING BODY FRAME	7351.00	1
2	RIDGING BODY	7467.00	1
ITEMS 3.1 TO 3.9 AS FOLLOWS :-			
QUANTITIES ARE APPLICABLE TO ONE SPRING TINE ASSEMBLY			
3.1	SPRING TINE	5989.00	1
3.2	A-SHARE (SEE DRAWING FOR PART NUMBERS)		1
3.3	M10 SHARE BOLT	7812	1
3.4	M10 HEX . NUT BZP	1150	1
3.5	M12x50 FINE THREAD BOLT BZP	7709	1
3.6	M12 THIN WASHER BZP	7877	1
3.7	SPRING TINE CLAMP	5992.00	1
3.8	M12 THIN WASHER BZP	7877	1
3.9	M12 FINE THREAD NYLOC NUT BZP	7487	1
3.19	M10 FLAT WASHER		1
4	M16x80 BOLT BZP	8995	2
5	M16 HEX. HALF NUT BZP	6865	3
6	M16x45 BOLT BZP	5664	1
7	M16 FLAT WASHER BZP	7878	2
8	M16 SPRING WASHER BZP	1119	2
9	M16x50 BOLT BZP	9126	2
10	RIDGING BODY POINT	7670.00	1
11	M10 HEX. NUT	1150	2
12	M10x25 SHARE BOLT	7812	2
13	5MM ROLL PIN		1

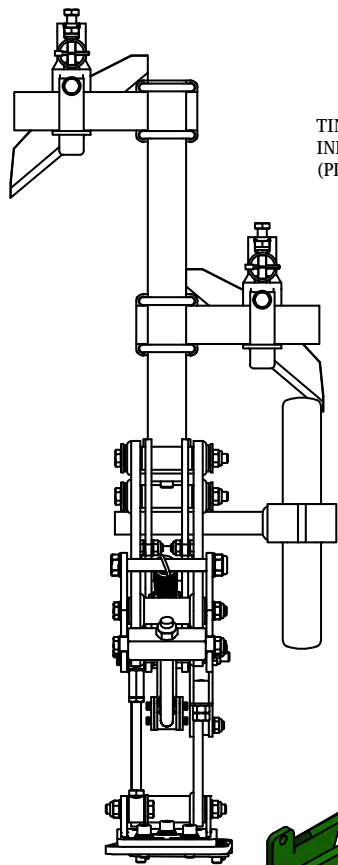

TINE FRAME SHOWN FITTED TO INROW SUPPORT WHEEL ASSEMBLY. (PLAN VIEW ALSO SHOWN).

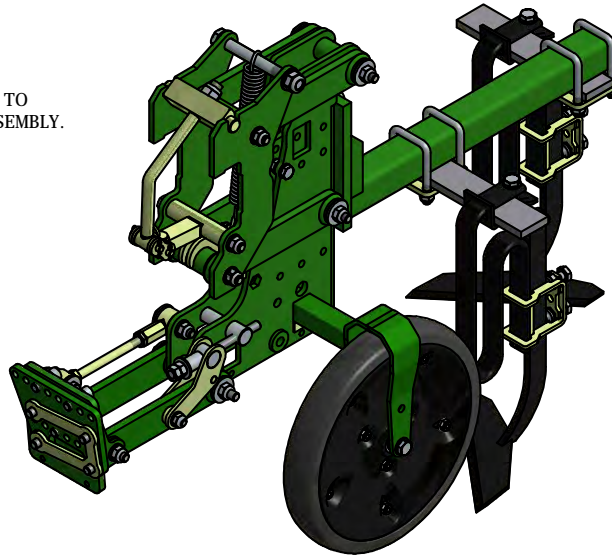

TINE WINGS ARE MANUFACTURED FOR SPECIFIC ROW WIDTHS. REFER TO GARFORD FARM MACHINERY LTD WITH MACHINE SERIAL NUMBER.

ITEMS 2, 3 & 4 AVAILABLE AS 8673.00 TINE FRAME CLAMP.

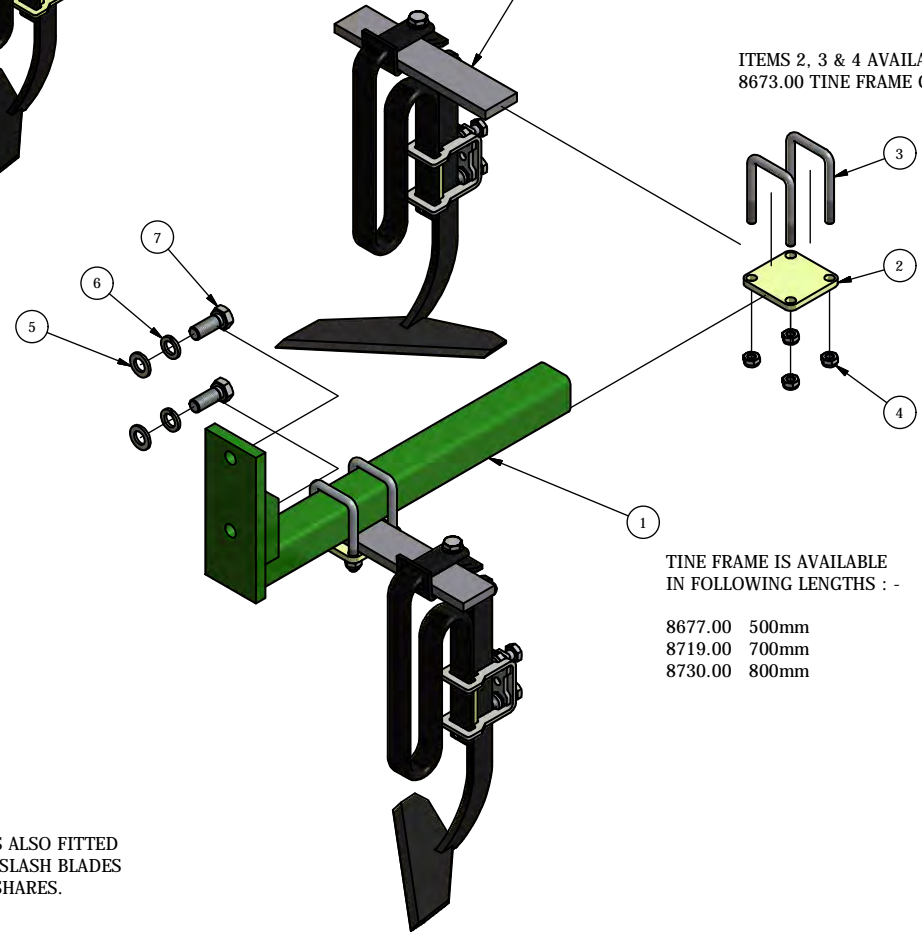

TINE FRAME IS AVAILABLE IN FOLLOWING LENGTHS : -

8677.00	500mm
8719.00	700mm
8730.00	800mm

INROW TINE FRAME IS ALSO FITTED TO DISK STEER UNIT. SLASH BLADES ARE REPLACED BY A-SHARES.

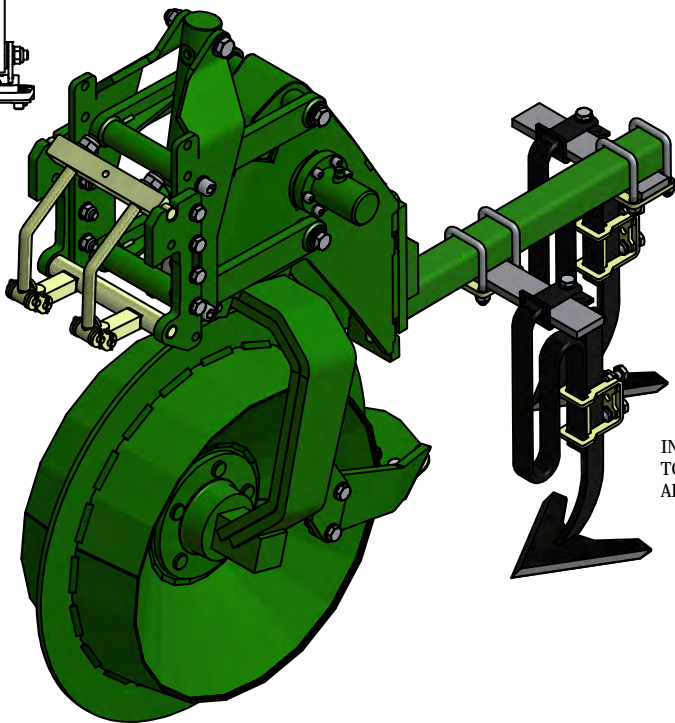

ROBOCROP IN ROW TINE FRAME ASSEMBLY

ITEM No.	DESCRIPTION	PART No.	QUANTITY
1	TINE FRAME (SEE DRAWING FOR PART NUMBERS)		1
2	FRAME CLAMP PLATE	8673.00	2
3	U-BOLT 50x50xM10	8672.00	4
4	M10 NYLOC NUT BZP	1024	8
5	M16 FLAT WASHER BZP	7878	2
6	M16 SPRING WASHER BZP	1119	2
7	M16x40 BOLT BZP	5837	2

11

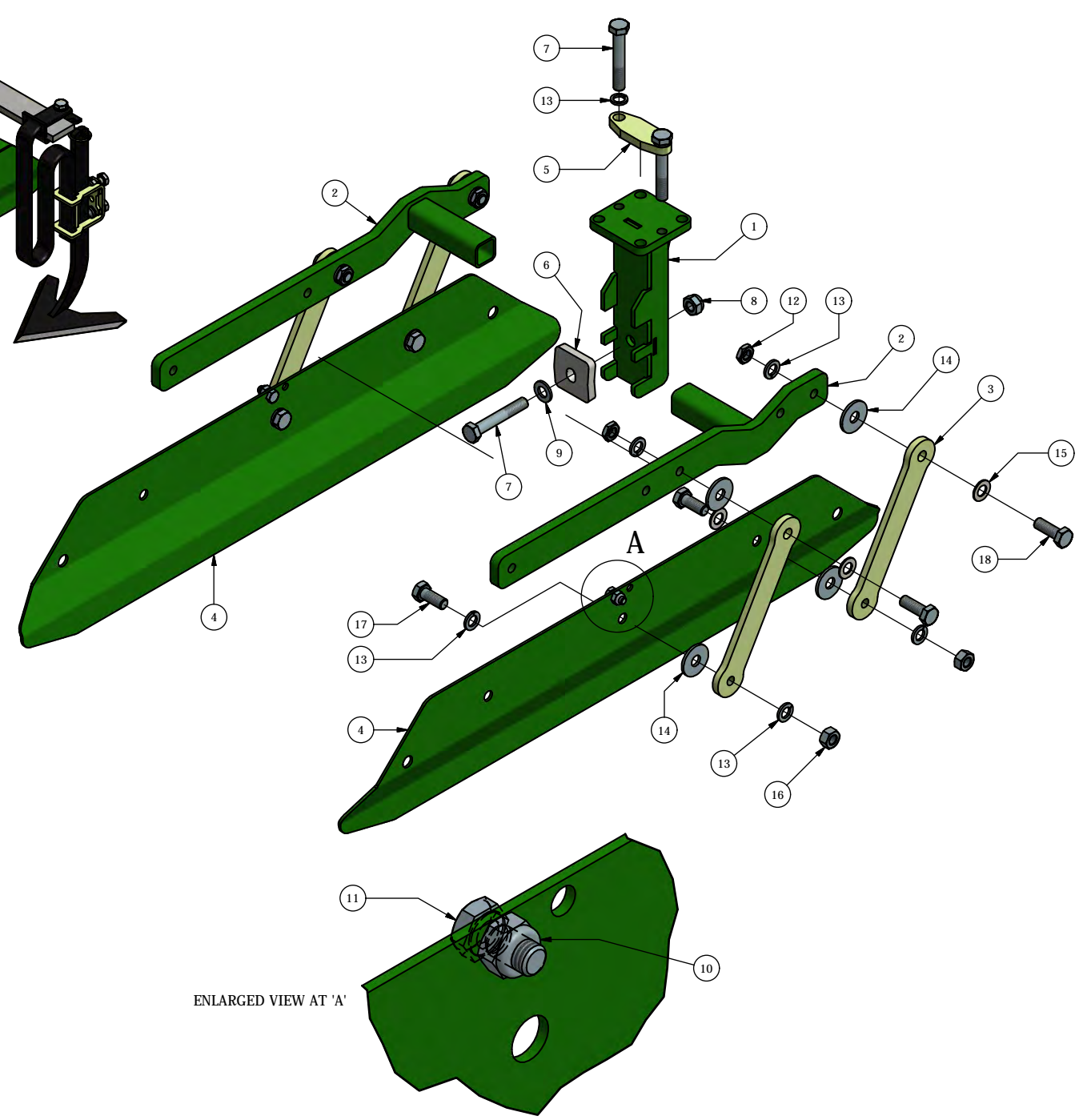
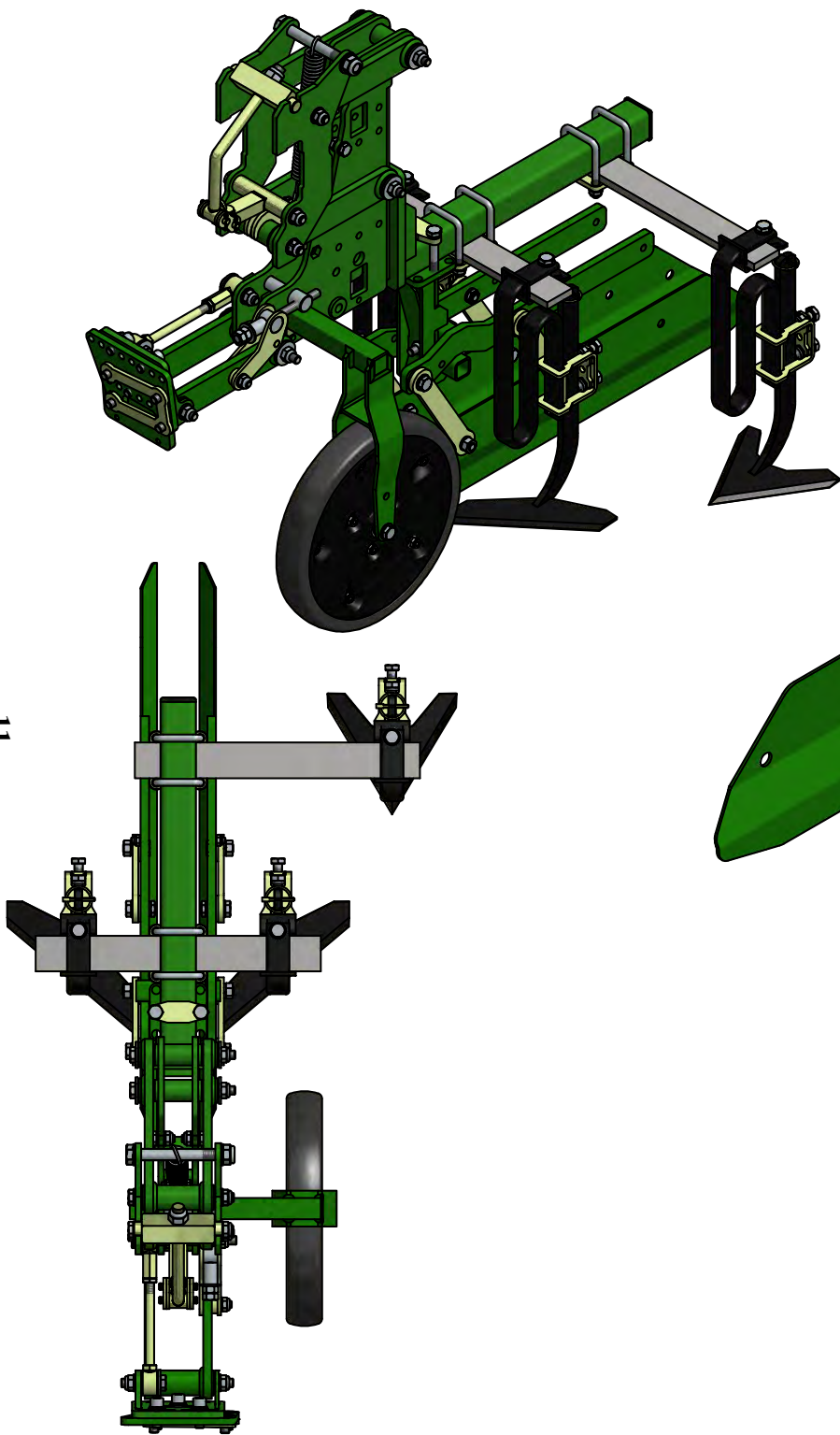

ENLARGED VIEW AT 'A'

ROBOCROP CROP PROTECTION SHIELDS

ITEM No.	DESCRIPTION	PART No.	QUANTITY
1	IN ROW SIDE SHIELD MOUNTING BRACKET	10229.00	1
2	SIDE SHIELD MOUNTING ARM	10228.00	2
3	PARALLEL LINK	5930.01	4
4	SIDE SHIELD	9721.00	2
5	SIDE SHIELD MOUNTING CLAMP PLATE	10231.00	1
6	SIDE SHIELD ARM CLAMP PLATE	10230.00	1
7	M12x75 BOLT BZP		3
8	M12 NYLOC NUT BZP		1
9	M12 FLAT WASHER BZP		1
10	M8 NYLOC NUT BZP	1042	2
11	M8x16 BOLT BZP	1156	2
12	M12 HALF NUT BZP	5833	4
13	M12 SPRING WASHER BZP	1115	12
14	LARGE OD FLAT WASHER 12x37x3 BZP	9068	8
15	M12 THIN WASHER BZP	7877	6
16	M12 HEX NUT BZP		4
17	M12x30 BOLT BZP	1161	4
18	M12x35 BOLT BZP	1014	4

Plant Zone 6cm

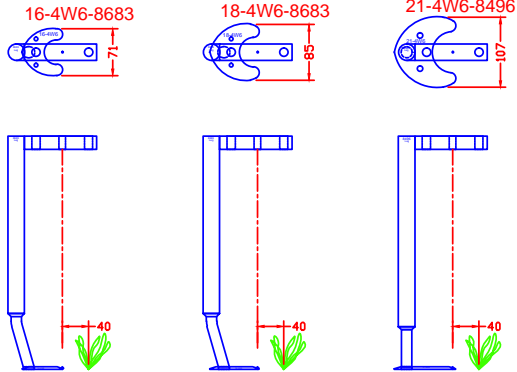

Plant Zone 7cm

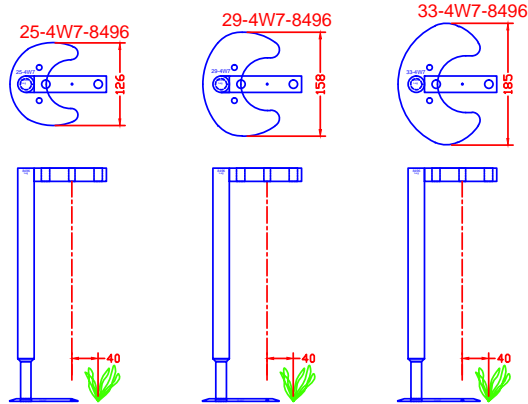

Plant Zone 10cm

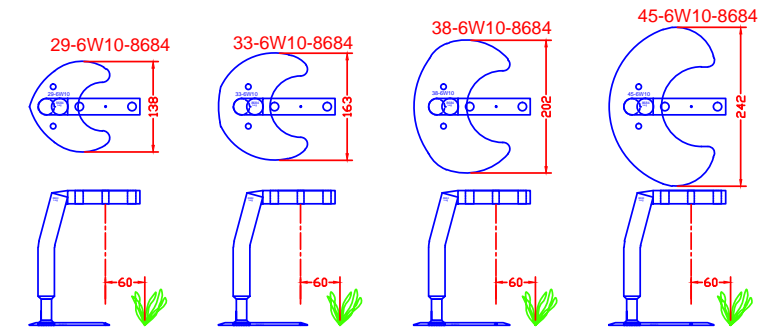
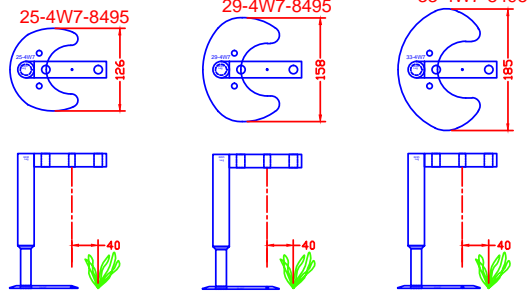
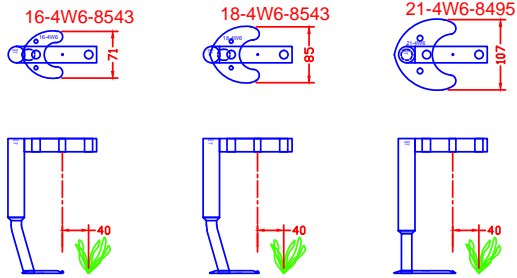
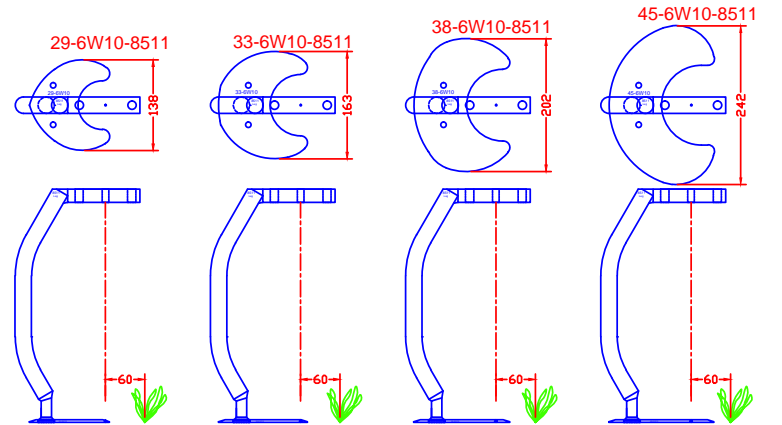

ROBOCROP IN ROW DISC SIZES & DISC LEGS

THE CHART ON OPPOSITE PAGE SHOWS AVAILABLE RANGE FOR GIVEN PLANT ZONES.

