

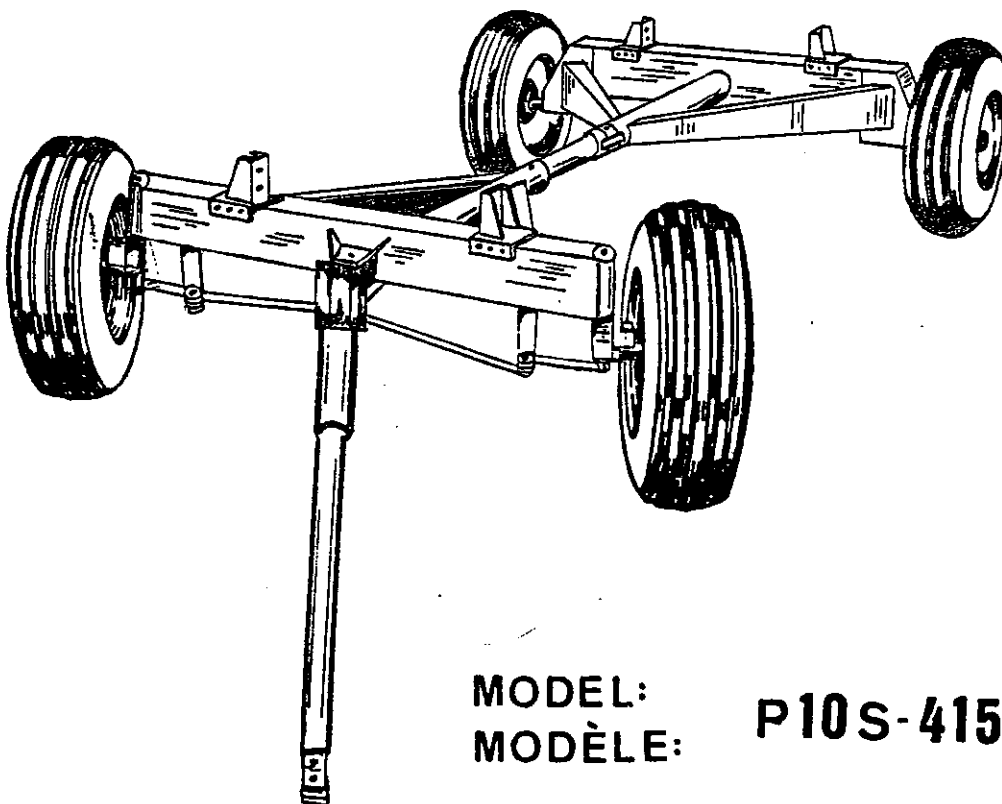

WAGONS

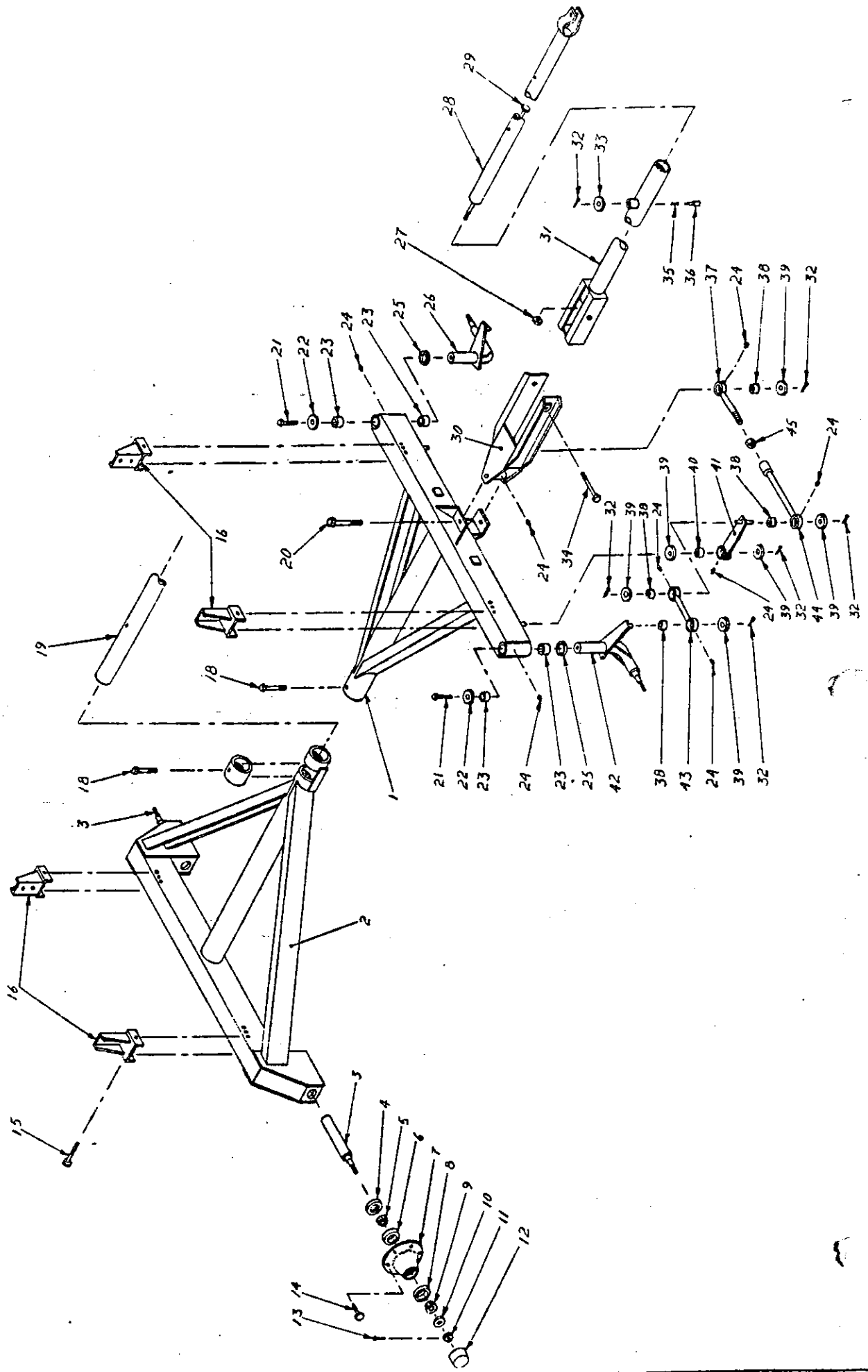

MODEL: P10S-415/416
MODÈLE:



NO.	NO. PIECE PART NO.	DESCRIPTION	QTE. QTY.
1	10101	Train-avant, assemblée soudée	1
1	10101	Fore carriage, welded assembly	1
2	10102	Train arrière, assemblée soudée	1
2	10102	Hind carriage, welded assembly	1
3	10103	Essieux	2
3	10103	Spindle	2
4	10104	Bague étanche # 20148	4
4	10104	Oil seal # 20148	4
5	10105	Cône, coussinet à rouleaux intérieur Timken # 603049	4
5	10105	Cone, inner roller bearing Timken # 603049	4
6	10106	Bague, coussinet à rouleaux intérieur Timken # 603011	4
6	10106	Cup, inner roller bearing Timken # 603011	4
7	10107	Moyeux 5000 lbs. "Martin"	4
7	10107	Hub 5000 lbs. "Martin"	4
8	10108	Bague, coussinet à rouleaux extérieur Timken # 48548	4
8	10108	Cup, outer roller bearing Timken # 48548	4
9	10109	Cône, coussinet à rouleaux extérieur Timken # 48510	4
9	10109	Cone, outer roller bearing Timken # 48510	4
10	STANDARD	Rondelle plate 7/8" DI.	4
10	STANDARD	Flat washer 7/8" ID.	4
11	STANDARD	Ecrou crenelé 7/8"-14 NF	4
11	STANDARD	Slotted nut 7/8"-14 NF	4
12	10110	Capuchon	4
12	10110	Cap	4
13	STANDARD	Goupille sur écrou crenelé 5/32" x 1 1/2"	4
13	STANDARD	Cutter pin on slotted nut 5/32" x 1 1/2"	4
14	10111	Vis de jante 9/16"-18 NF	24
14	10111	Rim screw 9/16"-18 NF	24
15	STANDARD	Boulon 1/2"-13 NC x 5", rondelle d'arrêt, écrou	4
15	STANDARD	Bolt 1/2"-13 NC x 5", lock washer, nut	4
16	10112	Epée ajustable	4
16	10112	Ajustable stake	4
17	10113	Bague de perche	1
17	10113	Tubular reach ring	1
18	STANDARD	Boulon 3/4"-10 NC x 5", rondelle d'arrêt, écrou	2
18	STANDARD	Bolt 3/4"-10 NC x 5", lock washer, nut	2
19	10114	Perche tubulaire 3 1/2" dia. x 96"	1
19	10114	Tubular reach 3 1/2" dia. x 96"	1
20	STANDARD	Boulon 1"-12 NF x 7", écrou à blocage de nylon	1
20	STANDARD	Bolt 1"-12 NF x 7", nylon lock nut	1
21	STANDARD	Boulon 3/8"-16 NC x 1", rondelle d'arrêt	2
21	STANDARD	Bolt 3/8"-16 NC x 1", lock washer	2
22	10115	Rondelle capuchon	2
22	10115	Washer cover	2
23	10116	Coussinet de brasse 2 1/4" DE. x 11G MUR x 1 1/2"	4
23	10116	Brass bushing 2 1/4" OD. x 11G MUR x 1 1/2"	4
24	STANDARD	Zerck de graissage, alemitte 1/4"-28 NF, droit	13
24	STANDARD	Lube fitting, alemitte 1/4"-28 NF, straight	13
25	10117	Rondelle machinée	2
25	10117	Machinery washer	2
26	10118	Essieu gauche avant	1
26	10118	Front left spindle	1
27	STANDARD	Ecrou à blocage de nylon 3/4"-16 NF	1
27	STANDARD	Nylon lock nut 3/4"-16 NF	1

NO.	NO. PIECE PART NO.	DESCRIPTION	QTE. QTY.
28	10119	Pôle de traction au tracteur	1
28	10119	Tractor stub pole	1
29	10120	Boulon de sécurité 3/4"-16 NF	1
29	10120	Safety rod 3/4"-16 NF	1
30	10121	Prise pivot de pôle	1
30	10121	Pole hitch	1
31	10122	Pôle télescopique au wagon	1
31	10122	Wagon telescopic pole	1
32	STANDARD	Goupille fendue 1/4" dia. x 1 1/2"	11
32	STANDARD	Cutter pin 1/4" dia. x 1 1/2"	11
33	10123	Rondelle pour barrure	1
33	10123	Handle washer	1
34	STANDARD	Boulon 3/4"-16 NF x 8", écrou à blocage de nylon	1
34	STANDARD	Bolt 3/4"-16 NF x 8", nylon lock nut	1
35	10124	Ressort	1
35	10124	Spring	1
36	10125	Cheville d'ajustement	1
36	10125	Hitch pin	1
37	10126	Barre de conduite filetée	2
37	10126	Threaded tie rod	2
38	10127	Coussinet de brasse 1 1/4" DE. x 11G MUR x 1"	8
38	10127	Brass bushing 1 1/4" OD. x 11G MUR x 1"	8
39	10128	Rondelle d'appui	12
39	10128	Flat washer	12
40	10129	Coussinet de brasse 1 1/4" DE. x 11G MUR x 1 1/2"	2
40	10129	Brass bushing 1 1/4" OD. x 11G MUR x 1 1/2"	2
41	10130	Barre de transfert	2
41	10130	Transfer bar	2
42	10131	Essieux droit avant	1
42	10131	Front right spindle	1
43	10132	Barre de conduite courte	2
43	10132	Short tie rod	2
44	10133	Barre de conduite longue	2
44	10133	Long tie rod	2
45	STANDARD	Ecrou 1"-12 NF	2
45	STANDARD	Nut 1"-12NF	2