



# *Matador 7900*

*Operator's Manual*

*June 2009*



**AgLand**  
INDUSTRIES INC.

## Replacement Parts

To obtain prompt, efficient service, give your dealer the following information.

1. Correct stock number of part.
2. Model number of the machine.
3. Serial number of the machine.

The serial number is important in identifying your machine. It contains information for ordering replacement parts and options which may vary depending on the serial number identification.

Measurements are given in U.S. units followed by the equivalent in metric units. Hardware sizes are given in inches for the U.S. hardware and millimeters for the metric hardware.

<b>AgLand</b>	
Box 479 Arborg MB, R0C 0A0	
<b>Model #:</b>	Matador 7900
<b>Serial #:</b>	
Made in Canada	

Serial # on plate inside hitch.

<b>Warranty Registration Form .....</b>	<b>3</b>
<b>Introduction.....</b>	<b>5</b>
<b>Safety.....</b>	<b>6-7</b>
Transport Safety .....	6
Operating Safety.....	7
Hydraulic Safety.....	7
<b>Safety Decals .....</b>	<b>8</b>
<b>Specifications .....</b>	<b>9</b>
<b>Assembly .....</b>	<b>10-12</b>
Wheel Assembly .....	10
Moldboard Attachment .....	11
Hydraulic Lift Kit.....	12
<b>Operation.....</b>	<b>13-14</b>
Level Inverter .....	13
Uneven Fields - Flotation Spring Adjustment .....	13
Pickup Finger Height - Gauge Wheel Adjustment .....	13
Setting Pickup Speed.....	14
Direction of Travel.....	14
<b>Maintenance .....</b>	<b>15-18</b>
Setting Drive Chain Tension.....	15
Roller Drive Chain Replacement .....	16
Bearing Replacement .....	16
Replacing or Repacking Wheel Bearings.....	16
Pickup Teeth, Bands, Wear Strips .....	17
Flotation Spring Adjustment.....	17
Torque Charts for Bolts and Nuts.....	18
<b>Lubrication .....</b>	<b>19</b>
<b>Hydraulics Assembly Instructions .....</b>	<b>20-21</b>
<b>Troubleshooting .....</b>	<b>22-23</b>
<b>Warranty .....</b>	<b>Back Cover</b>





# AgLand Matador 7900™ Windrow Inverter

## LIMITED WARRANTY REGISTRATION FORM

AgLand Industries Inc. warrants to the original owner of the Matador 7900 Windrow Inverter to be free of defects in workmanship and material for a period of one (1) year from the date of purchase for farm use (**three (3) months from date of purchase for commercial use**). AgLand does not warrant any damage caused by negligence, modifications, and/or lack of maintenance (see Maintenance Schedule in Operator's Manual).

AgLand will not be liable for the cost of shipping or any other cost incurred for replacement or repair of any parts. AgLand is not liable for any accidents which may occur from or during the operation of the Matador 7900 Windrow Inverter, or damage incurred due to Matador failure. The purchaser assumes all responsibility for the care, maintenance and safety.

**See back of the Operator's Manual for complete warranty details.**

Failure to return completed registration to AgLand within thirty (30) days of delivery will VOID the warranty.

This form must be filled out by the dealer and signed by both dealer and customer.

Mail to:

AgLand Industries Inc.  
Box 479, Arborg, MB  
ROC 0A0

<b>Customer Name:</b> _____	<b>Dealer:</b> _____
Address: _____	Address: _____
City: _____	City: _____
Prov/State: _____ Postal/Zip: _____	Prov/State: _____ Postal/Zip: _____
Phone No: _____	Phone No: _____
Model No: _____	Date Purchased: _____
Serial No: _____	Check One: <input type="checkbox"/> Farm Use <input type="checkbox"/> Commercial Use

### DEALER CHECKLIST

- |   |  |
|---|--|
| <input type="checkbox"/> Chain tension, checked and adjusted                                    | <input type="checkbox"/> Tire air pressure (32 PSI maximum (221 kPa))  |
| <input type="checkbox"/> Pickup, including finger height, adjusted and set                      | <input type="checkbox"/> All grease fittings greased   |
| <input type="checkbox"/> Flotation spring, checked and adjusted                                 | <input type="checkbox"/> All safety procedures have been reviewed with customer  |
| <input type="checkbox"/> Hydraulic line and fittings checked for leaks and rubbing moving parts | <input type="checkbox"/> All warning decals are in place, clean, and legible   |
| <input type="checkbox"/> All reflectors in place  | <input type="checkbox"/> Customer has been instructed to review safety and operating procedures with all operators annually. |
| <input type="checkbox"/> Wheel bolts tight  |  |

*I have thoroughly inspected the machine and made adjustments and corrections as needed.*

_____	_____	_____
<i>Inspected By</i>	<i>Signature</i>	<i>Date</i>

*I have instructed the buyer on the above described equipment and included a review of the Operator's Manual, assembly, maintenance, safety, and applicable warranty policy.*

_____	_____
<i>Dealer's Signature</i>	<i>Date</i>

*The above Equipment and Operator's Manual have been received by me and I have been instructed as to the care, adjustments, safe operation, and applicable warranty policy.*

_____	_____
<i>Purchaser's Signature</i>	<i>Date</i>



**Congratulations, you have just purchased the Matador 7900 Windrow Inverter, the only true inverter on the market today. To get the maximum benefit from your Matador we suggest that you read this manual carefully.**



The Matador 7900 Windrow Inverter is designed to turn and move hay swaths for a faster dry down. The Matador utilizes a low profile, heavy duty pickup with extra width to allow rapid operation with minimal leaf loss.

The moldboard of the Matador 7900 Windrow Inverter is a patented design giving a 180° turn to the swath when the machine is operated correctly.

These operating and maintenance instructions have been compiled from extensive field experience and engineering data. Some information is general in nature due to unknown and varying conditions. However, through experience and these instructions, you will be able to develop operating procedures suitable to your particular situation.

Please study this manual from beginning to end BEFORE operating your new Matador 7900. Pay special attention to the Safety section in this manual and the safety cautions on your equipment. Should anyone else operate this equipment be sure that they understand ALL safety, operating and maintenance information presented in this manual.

The terms 'right' and 'left' as used throughout this manual are determined by facing the direction the machine will travel when in use.

The photographs, illustrations, and data used in this manual were current at the time of printing, but due to possible in-line production changes, your machine may vary slightly in detail. The Manufacturer reserves the right to redesign and change the machine as necessary without notification.

## **WARNING**

Some pictures in this manual show the machine with shields removed to allow for a better view of the subject. The machine must never be operated with any of the shields removed.

**AgLand Industries Inc.** is a Canadian owned and operated company located in central Canada, in the province of Manitoba. AgLand was founded in 2001 by a group of innovative young men that transformed their ideas and expertise into a leading manufacturing company of agricultural crop equipment.

Box 479, Arborg, MB, Canada ROC OAO

**1.888.933.4440**

Tel: 204.364.2211

Fax: 204.364.2472

Email: [sales@aglandindustries.com](mailto:sales@aglandindustries.com)

Web: [www.aglandindustries.com](http://www.aglandindustries.com)



# Safety

**Read this manual completely and understand all operating instructions and precautions BEFORE attempting to operate or service your machine.**

The safety information given in this manual does not replace safety codes, insurance needs, or state/province and local laws. Make sure your machine meets all standards required by the local laws and regulations.

Understand that your safety, and the safety of others, is measured by how you service and operate this machine.

**IMPORTANT!** Review and understand the positions and functions of all machine controls before operating this machine.

**WARNING!** Do NOT attempt any adjustments, maintenance, troubleshooting, or repairs while machine components are moving or activated with pressure.

- Lower machine to ground or onto appropriate blocks.
- Stop tractor engine and remove ignition key.
- Set tractor parking brake prior to leaving operator station.

## Safety Alert Symbol

The Safety Alert symbol identifies important safety messages in the manual and on the machine. When you see this symbol, be alert to the possibility of personal injury or death. Follow all instructions in the safety message given. This symbol means attention, be alert, and your safety is involved.



Three Reasons To Follow Safety Instructions:

1. Accidents disable and kill.
2. Accidents cost.
3. Accidents can be avoided.

## Slow Moving Vehicle Emblem

The Slow Moving Vehicle (SMV) emblem must be placed on the rear of the machine and be visible to traffic approaching the machine from the rear while traveling on public roads. Keep the SMV emblem clean and replace when damaged or when emblem materials have faded. The SMV should only be displayed on the machine at road speeds less than 25 MPH (40 km/h).



## Signal Words

# DANGER

**DANGER:** Indicates an imminently hazardous situation that, if not avoided, WILL result in death or serious injury if proper precautions are not taken.

# WARNING

**WARNING:** Indicates a potentially hazardous situation that, if not avoided, COULD result in death or serious injury if proper precautions are not taken.

# CAUTION

**CAUTION:** Indicates a potentially hazardous situation that, if not avoided, MAY result in minor or moderate injury if proper practices are not taken, or serves as a reminder to follow appropriate safety practices.

## Transport Safety

- The operator is responsible for complying with all local regulations regarding transporting agricultural equipment on public roads and highways.
- Ensure all lights and reflectors, as required by local law, are in place, intact, and clean before transporting machine on public roads and highways.
- Ensure SMV emblem is clean and properly displayed, where required by law, before transporting machine on public roads and highways.
- Do NOT allow riders on machine at any time including transport of machine on public roads and highways.
- Maximum transport speed is 20 MPH (32 km/h). Reduce speed on rough roads and surfaces.
- Use proper retainer on drawbar hitch pin and attach safety tow chain to tractor prior to transporting machine on public roads and highways.
- When using a ball and socket, make sure the locking jaws are pinned securely in position.
- Do not rely on the pickup lift hydraulic cylinder to keep the pickup raised. Be sure pickup reel is in raised position and lever is secured with the pickup travel lock pin provided.





Hitch and safety chain.



Pickup lift with travel lock pin.

## Operating Safety

- REVIEW ALL SAFETY INSTRUCTIONS with all operators before allowing them to operate the equipment. Review instructions at least once each year.
- All shields and guards must be intact and in position and securely fastened before operating the Windrow Inverter.
- Only use a tractor equipped with ROPS cab and seat belt. Be careful when operating close to a road or building, the machine can throw stones and other objects during operation.
- Emphasize the importance of safety when working around and operating the machine.
- Do NOT allow riders on any part of the equipment at any time.
- Always keep hands, feet, and clothing away from moving parts.
- Always lower the pickup to the ground when parking.
- Use a retainer or draw pin to secure the lifting lever of the pickup before transporting equipment.
- Use safety tow chain at all times.
- NEVER attempt to unplug the machine when the tractor is running and hydraulic system is pressurized.
- Keep hands, feet, and clothing away from the pickup area when in operation to avoid entanglement hazards. Do not open or remove shields or guards while machine is running.
- Relieve all pressure from hydraulic lines before disconnecting them. Before applying pressure to the system, make sure all connections are tight and that hoses and lines have not been damaged.

## Hydraulic Safety

- Ensure that all components in the hydraulic system are kept in good condition.
- Replace any worn, cut, abraded, flattened, or crimped hoses and/or metal lines.
- Do not attempt any poorly executed repairs to hydraulic lines, fittings, or hoses by using tape, clamps, or cements. The hydraulic system operates under extremely high pressure: 1600 to 2300 PSI (11,033 to 15,859 kPa). Such repair will fail suddenly and create unsafe conditions.
- Wear proper hand and face protection (e.g. face shield) when searching for a high pressure hydraulic leak. Use a piece of wood or cardboard as a backdrop instead of hands. A high pressure concentrated stream of hydraulic fluid can pierce the skin. If this should happen, seek immediate medical attention as infection and toxic reaction could develop.
- Before applying hydraulic pressure to the system, ensure all connections are tight and that lines, hoses, and couplings are not damaged.

**Think Safety,  
Work Safely!**



# Safety Decals

## Moving Parts Hazard

**! DANGER!**



**MOVING PARTS HAZARD**

To prevent serious injury or death from moving parts:

- KEEP AWAY, Moving Parts can crush and dismember.
- Do not operate without guards and shields in place.
- Close and secure guards and shields before starting.
- Keep hands, feet, hair, and clothing away from moving parts.
- Disconnect and lockout power source before adjusting or servicing.
- Do not stand or climb on machine when operating.

DC0063

## High Pressure Fluid Hazard

**! WARNING!**



**HIGH PRESSURE FLUID HAZARD**

To prevent serious injury or death:

- Relieve pressure on system before repairing, adjusting or disconnecting.
- Wear proper hand and eye protection when searching for leaks. Use wood or cardboard instead of hands.
- Keep all components in good repair.

DC0068

## Keep Shields and Guards in Place

**! DANGER!**



**KEEP SHIELDS AND GUARDS IN PLACE**

DC0064

## AgLand Matador Model 7900

### Dimensions

Overall Width	102" to 104" (259 cm to 264 cm)
Length	with rear hitch extended 187" (475 cm) with rear hitch removed 175" (444 cm)
Height	with pickup lowered 46" (117 cm) with pickup raised 48" (122 cm)
Weight	1,350 lbs. (613 kg)

### Tires (4)

Main Tire Size	5.90 x 15
Pressure	30 PSI (207 kPa)
Wheel Hub	4 bolt
Wheel Torque	85 ft-lbs. (115.2 Nm)
Gauge Wheel Tire Size	4.8 x 8.50
Pressure	50 PSI (345 kPa)

### Pickup

Width	77" (196 cm)
Clearance*	15" to 17" (38 cm to 43 cm)
Tooth Clearance**	13.5" to 15" (34 cm to 38 cm)
Pickup Tooth Spacing	2.75" (7 cm)
RPM of Pickup Shaft	10 to 400 RPM
Drive System	Hydraulic motor, Roller chain driving two full width roller drums.
Height When Working	19" (48 cm)

\* under pickup when raised

\*\* when raised

### Operating Speed

Approximate range\* 5 to 10 MPH (8 to 16 km/hr)

\* depending on crop conditions

### Swath Size

Width up to 36" to 42" (91 cm to 107 cm)

### Tractor Requirements

Suggested min. tractor size\* 50 HP (37 KW)

Hydraulic Outlets Required two double acting outlets  
1,500 to 2,000 PSI range (10,343 kPa to 13,790 kPa)

Suggested minimum hydraulic flow rate  
10 US GPM (38 L/min)

Suggested minimum underframe clearance\*\*  
15" (38 cm)

Suggested minimum front and rear wheel tread\*\*\*  
66" (168 cm)

\* tractor should be of sufficient size to maintain operator control in all situations.

\*\* to allow swath to flow freely under tractor

\*\*\* adjusted to avoid contact with inverter during sharp corners

Some weights and measurements are approximate.

All specifications, statements and information shown in this manual are believed to be accurate at the time of printing. Specifications are subject to change without notice.

# Assembly

Depending on shipment destination, the Matador 7900 may be shipped assembled and ready for use; or some peripherals may be shipped separately as follows:

1. Wheel Kit
2. Moldboard Attachment
3. Lift Kit (Optional)

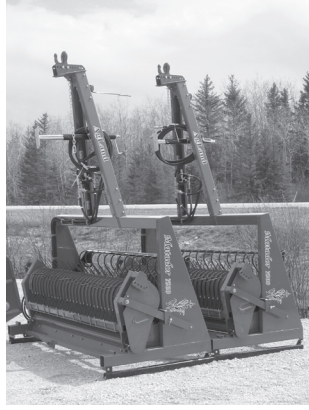

## Wheel Assembly

If the main frame is standing in a vertical position with the hitch pointing upward, lower machine to a horizontal position and secure with blocks. If you have a block and tackle, you may wish to lift the entire unit off the ground to assemble and install the wheels.



## Rear Wheel Installation

Install left and right hand brackets with slotted holes to the bottom (with pipe extended outward as shown). Move bracket in from back of frame and attach with  $5/8" \times 5"$  bolt and spring washers (A). Flat washers for slotted holes only (B).

Install rear wheel hub/axle assemblies in axle tubes, leaving a gap sufficient to clear guards, hoses, etc. Tighten  $1/2" \times 1-1/2"$  set screw and lock nut (C).

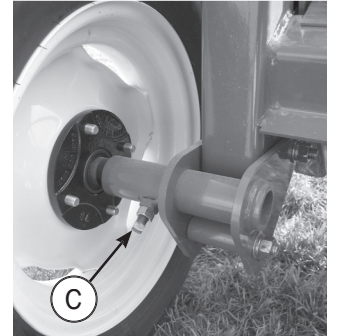
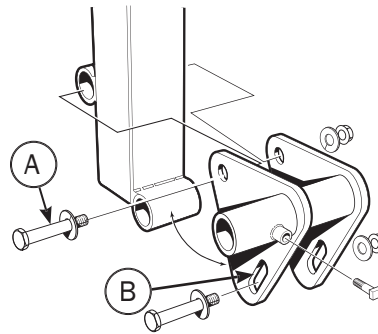
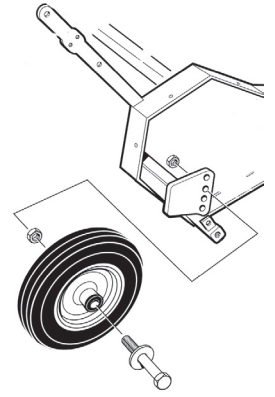

## Gauge Wheel Installation (Small Wheels)

Install gauge wheels with  $3/4" \times 7"$  grade 8 bolts in second hole from top of adjustment plate. Tighten nuts securely ensuring the wheel turns freely. Install with a nut on either side of mount bracket. Grease gauge wheels before use.

## Moldboard Attachment

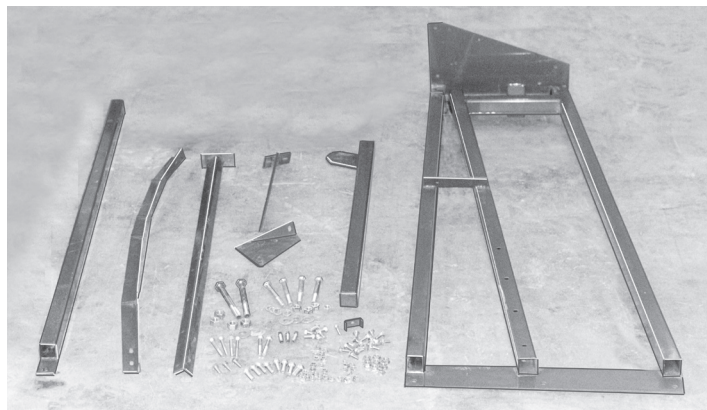

Moldboard kit (moldboard sheet not shown)

## Moldboard Frame Assembly

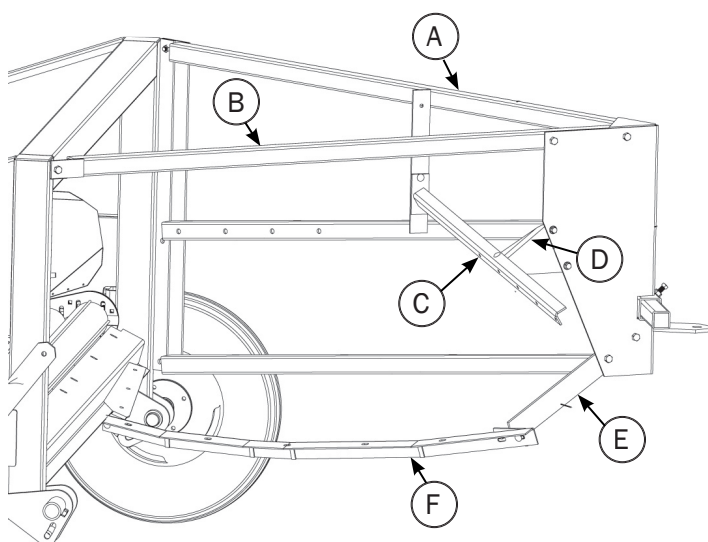

1. Install right hand moldboard frame assembly (A) with 1/2" x 1" bolts, lock washers and nuts; do not tighten.
2. Install top left long square tube (front tab to outside of front main frame tab). Use 1/2" x 3-1/2" bolts from outside of plate at rear (B).
3. Loosely install angles and brackets (C, D & E), DO NOT tighten at this time.
4. Install lower curved angle (F) on centre, single tab on main frame (behind pickup), with the tab under the angle iron. Tighten in the fully forward position.
5. All bolts in the moldboard frame can now be fully tightened in the following sequence:
  - a. 1/2" x 1" bolt to the main frame
  - b. Lower curved angle bolts.
  - c. All remaining bolts.
6. Install hold down clamp on hoses at lower right.

## Moldboard Sheet Installation

1. Install sheet inside moldboard frame shown. Starting with the top right hand front (A), use 3/8" x 3" carriage bolts, then the top rear (B), use 3/8" x 1" bolts and nuts.
2. Install the bolts in the lower, curved angle (C) and tighten all bolts. DO NOT OVER TIGHTEN. Three bolts are required at the front edge of the moldboard (D). Some sheets are not predrilled. If this is the case, drill these holes from the bottom to 3/8" and install remaining bolts.

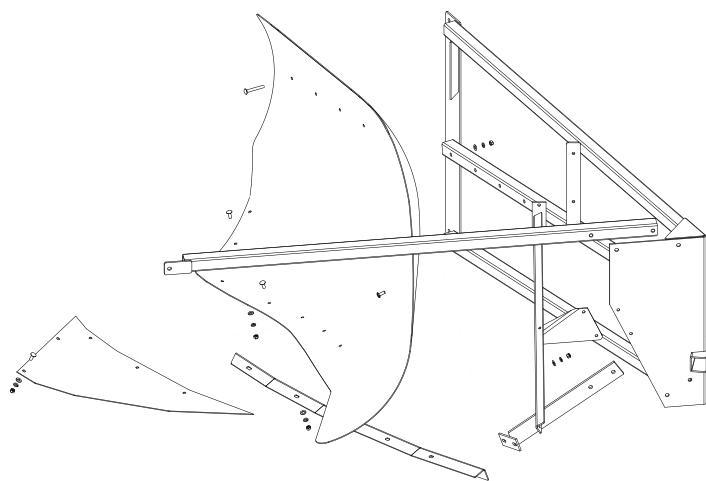
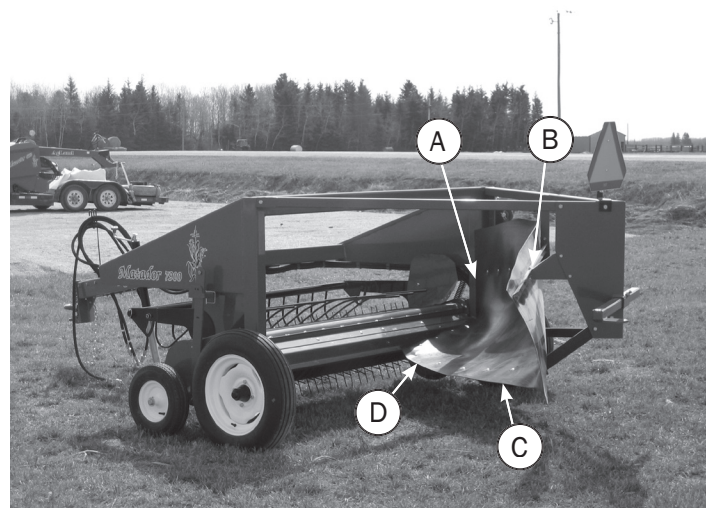



# Assembly

## Hydraulic Lift Kit

The pickup lift kit is an optional attachment available for all Matador Windrow Inverter models.

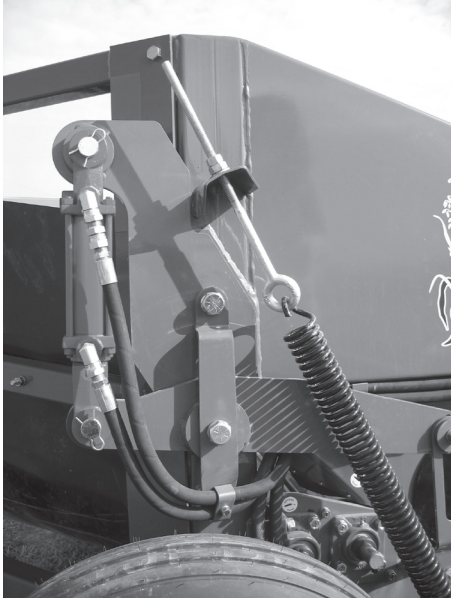

### Installation

1. Attach brackets (A) and (B) to main frame using 3/4" x 2" bolt (C), do not tighten.
2. Insert bushing (D) into 3/4" hole on horizontal arm (E). Slide arm (E) between brackets (A) and (B) so that holes line up. The flat washer (J) goes in between (A) and (E). Tighten to main frame using 3/4" x 3" bolt.

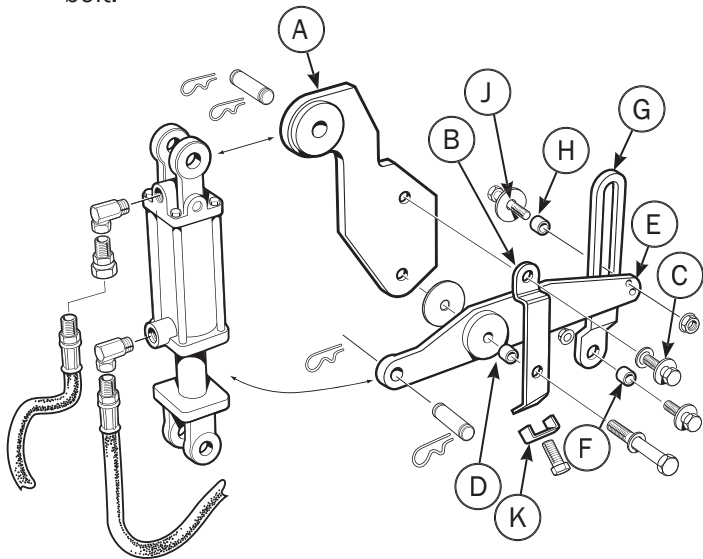

3. Insert bushing (F) into bottom hole on guide arm (G) and tighten guide arm to pickup using 1/2" x 1-1/2" bolt, nut and spring washer.
4. Insert bushing (H) into oval hole on guide arm (G).

From back of arm insert 1/2" x 1-3/4" bolt, using large flat washer (J) to hold bushing in horizontal arm (E) and tighten with nut and spring washer.

5. Attach hydraulic cylinder to lift kit using pin provided.
6. Install hose connectors (K).

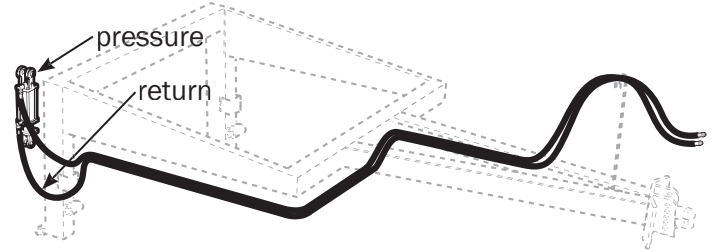

7. If hoses are not already installed, install as shown above.
8. Tighten all bolts and check to make sure hydraulic hoses are not rubbing.
9. Attach hoses to cylinder, pressure from tractor to bottom of cylinder, return hose to the top of the cylinder.



Use with a tractor having a minimum of 50 HP (37 KW). Tractor should have sufficient ground clearance for swath to pass cleanly under it.

## Level Inverter

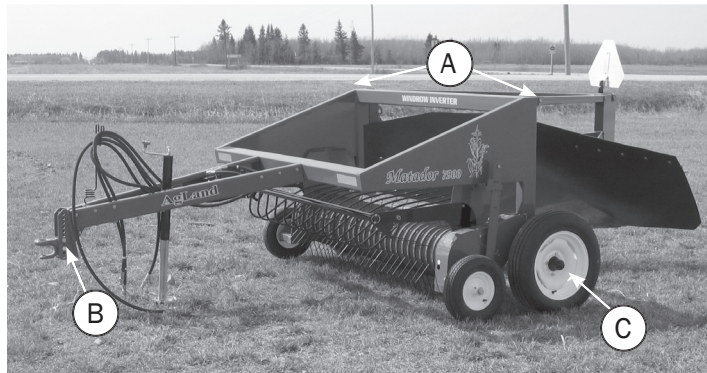

When hooked up to the tractor the windrow inverter rear frame should be parallel to the ground when measured across upper cross tube and rear corner of moldboard frame (A). If necessary level by changing the hitch tongue mounting bolt locations in the main frame and/or by inverting the tongue in the main frame brackets (B).

The axles can also be pivoted up or down on the main frame, in their slotted mounting holes (C).

Adjust tractor hitch if further adjustment is required.

## Uneven Fields

### Flotation Spring Adjustment

If pickup bounces too much due to uneven fields, release the spring tension. First loosen off top nut (A), then turn bottom nut (B) counter clockwise. This will put more weight on the pickup and should help minimize the bouncing action.

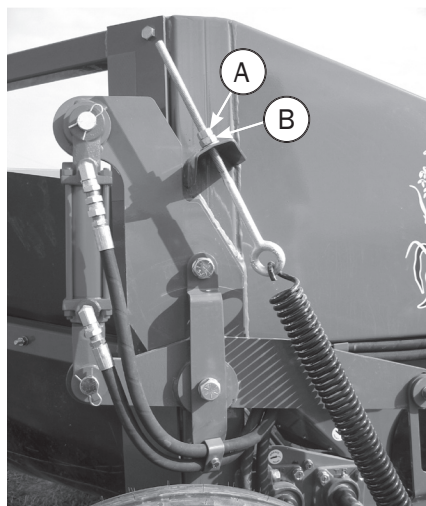

## Pickup Finger Height Gauge Wheel Adjustment (Small Wheels)

Check pickup height when in field position, crop should be picked up cleanly without gouging the soil. Should adjustment be required:

- a. Raise or lower pickup, Figure 1.
- b. Remove the nut on the bolt which holds the gauge wheel on the pickup and place bolt in the desired location, Figure 1. Tighten all nuts securely, ensuring that the wheel turns freely.

Ensure both left and right hand wheels are set at the same height.

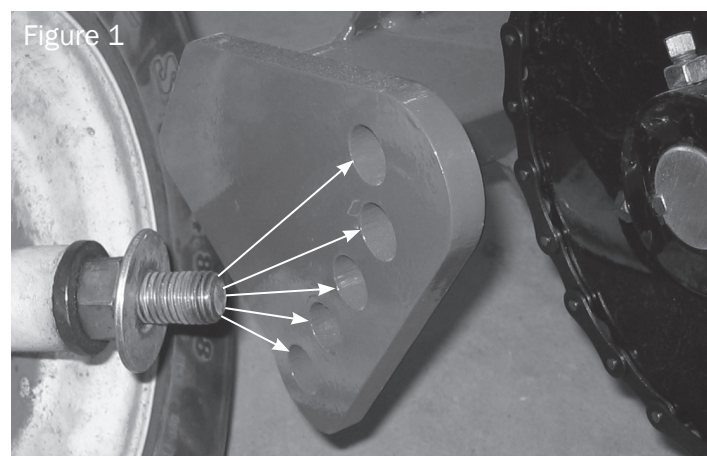

Figure 1

# Operation

## Setting Pickup Speed (Hydraulic Motor)

Lower the pickup to the ground. Engage the hydraulic lever on the tractor, which controls the hydraulic motor on the windrow inverter. The windrow inverter has a valve that prevents accidentally turning the pickup backward.

The hydraulic system for operating the windrow inverter consists of two basic components:

1. The hydraulic motor.
2. The adjustable flow control valve.

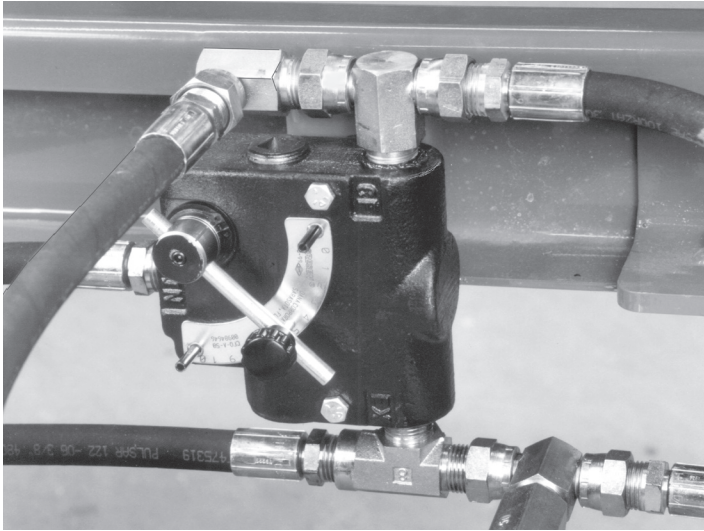

**Adjustable Flow Control Valve**

## If your tractor has a: CLOSED CENTRE TRACTOR HYDRAULIC SYSTEM WITH ADJUSTABLE VALVE:

1. Set the windrow inverter flow control at maximum setting of 10.
2. Engage the tractor hydraulic system lever.
3. Adjust the tractor flow control valve. If the oil surges through the system, close the windrow inverter flow control valve slowly until the surging stops.
4. Further windrow inverter valve adjustments may be necessary to ensure smooth and complete pickup at speed travelled.

## If your tractor has an: OPEN CENTRE HYDRAULIC SYSTEM WITHOUT AN AD- JUSTABLE VALVE:

1. Set the windrow inverter flow control valve in the 0 position.
2. Engage the tractor hydraulic system lever.
3. Set the pickup speed with the windrow inverter flow control valve to approximately 4 or 5.
4. Further adjustments may be necessary once you are inverting to ensure smooth and complete pickup at speed travelled.

## Direction of Travel

Start inverting at the same location and direction as mowing started, although the Matador Windrow Inverter will generally pickup “against the grain” as well. Centre the tractor and windrow inverter on the swath. Start gradually, and gear up smoothly, until you are operating at the desired field speed.

Adjust the hydraulic flow control on the tractor and/or the windrow inverter to change the pickup speed as required. Pickup speed should be sufficient to pickup crop cleanly. Excessive leaf loss will occur if pickup speed is too fast.

In cereal crops or crops with an “in line” orientation, it will be necessary to pick up the swath “head first.”

The hydraulic pickup lift kit makes it easy to raise the pickup over obstacles in the field or to skip a swath which does not need inverting.

With infinite variety of crop and field conditions, only operator experience will indicate best driving, cornering and adjustment techniques for maximizing the use of your Matador Windrow Inverter.

## Checklist

### CAUTION

#### Use Good Safety Practices When Working On This Machine

Before doing any maintenance or service on the machine you must:

- Park machine on a solid level surface.
- Disengage all power.
- Put the tractor transmission in PARK or apply the tractor parking brake.
- Stop the tractor engine and remove key from the ignition.
- Look and listen. Make sure all moving parts have stopped.
- Install the cylinder safety stops, if applicable.
- Block the inverter securely before working.

#### Daily

- Lubricate all items as required.
- Remove all dirt and crop deposits from machine.

#### After Every 8 Hours Of Use

- Grease gauge wheel bushings.

#### After The First 25 Hours Of Use

- Check sprockets for set screw tightness.

#### After Every 100 Hours Of Use

- Grease the sealed bearings on the pickup shaft (two locations, front roll (two places) and rear roll (four places)).

#### At The Beginning Of Each Season

- Review all safety instructions.
- Carefully inspect all components for excessive wear or hazardous conditions.
- Lubricate the machine at all lubrication points to force out any collected moisture.
- Check drive chain for correct tension, replace if worn or damaged.
- Clean and repack or replace the wheel bearings, if required.
- Check tires for correct inflation pressure.
- Tighten bolts.

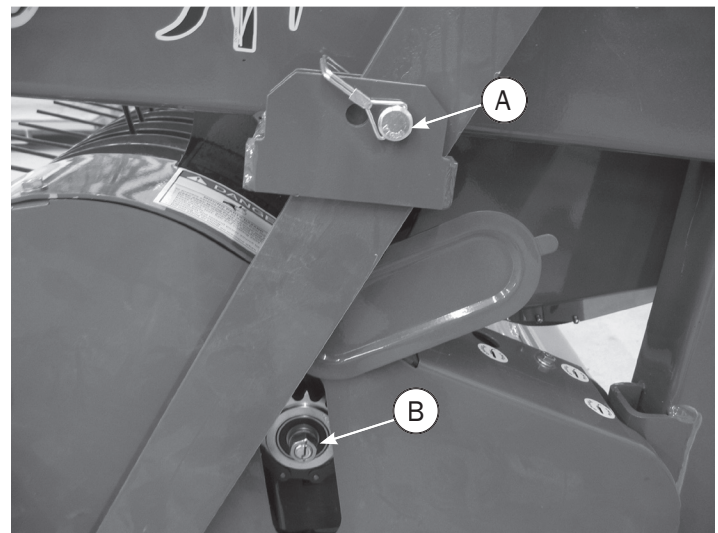

#### Setting Drive Chain Tension

1. Adjust tension with pickup pinned in raised position (A).
2. Inspect and adjust through the access hole provided in chain cover (B). The correct tension of the chain should allow for approximately 1/2" (1.3 cm) of deflection when slight pressure is applied to the longest span of chain (C). If required move sprocket (D) to increase or decrease tension on chain.
3. Check that the chain is not riding up on the sprocket teeth (especially the large sprocket) as this would indicate a worn out chain which requires replacement. Regular lubrication with chain lubricant, proper adjustment, and replacement of worn chains will ensure proper function of the Matador and prolong the life of the sprockets.



# Maintenance

## Roller Drive Chain Replacement

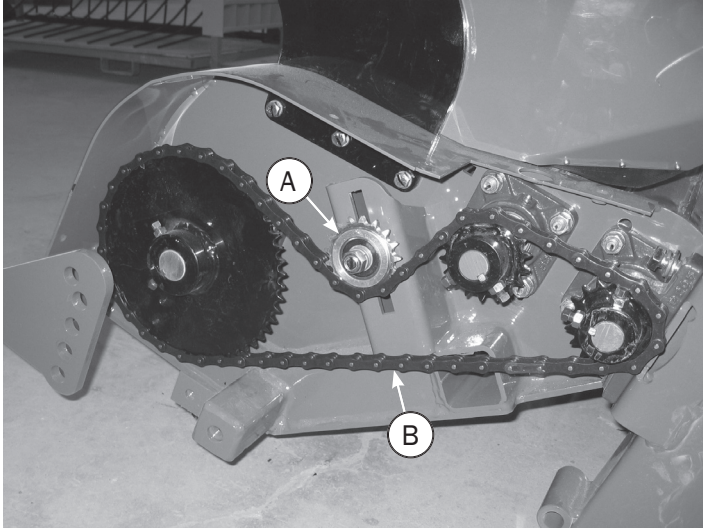

Replace worn or damaged chains as follows:

1. Lower pickup completely.
2. Remove chain cover.
3. Raise pickup and secure with pin.
4. Remove the connector link from the chain and remove chain from the sprockets.
5. Replace worn sprockets and bearings. (Ensure all sprockets are securely tightened.)
6. Install new chain.
7. Move sprocket (A) to allow for approximately 1/2" (13 mm) deflection when slight pressure is applied to the longest span of the chain (B).
8. Reinstall chain cover.

## Bearing Replacement

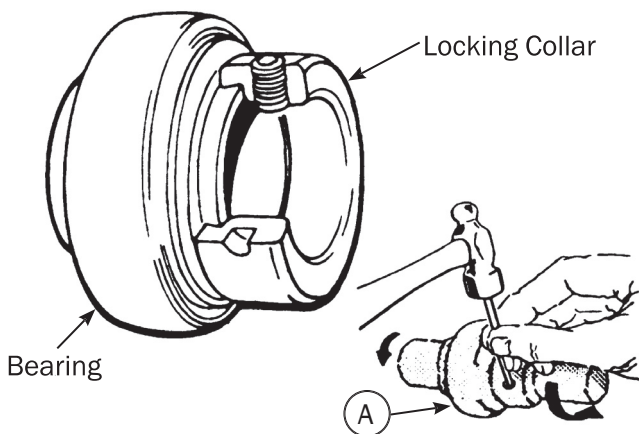

Sealed ball bearings are held in position on the shaft by a locking collar which is rotated to lock the assembly on the

shaft and secured by a set screw. To remove bearing:

1. Loosen set screw.
2. Use a drift punch inserted in the drift pin hole to rotate and loosen the locking collar (A). Rotate the locking collar counter clockwise.
3. Remove the locking collar.
4. Support the shaft, for easier assembly later.
5. Remove the bolts for the bearing flanges.
6. Slide the bearing and the flanges from the shaft. Note: Cleaning paint and corrosion from the shaft will make removal easier.
7. Put on the new bearings and flanges ensuring the bearing inner race is turned in a counter clockwise direction.
8. Install bolts ensuring the bearing is straight.
9. Replace locking collar on the shaft. Rotate the locking collar in direction of shaft rotation until lightly engaged. Tighten the collar by tapping it with a drift pin punch inserted in the drift pin hole rotating it further clockwise.
10. Tighten set screw.

## Replacing or Repacking Wheel Bearings

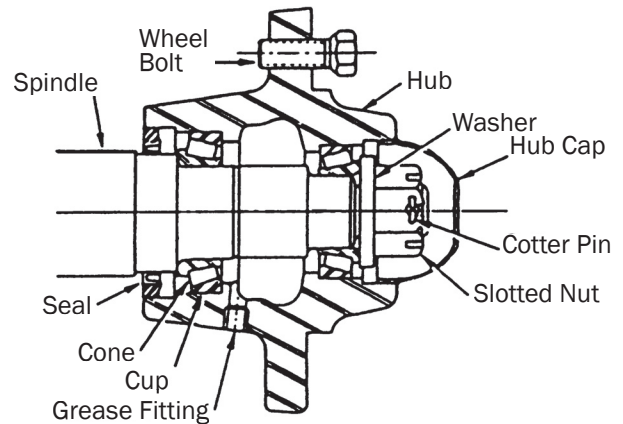

1. Remove wheel hub and disassemble.
2. Clean bearings, seals, caps, washers, nuts and hubs with kerosene or other solvent.
3. Replace bearings or seals if worn or damaged.
4. Pack bearing cones and seals with No. 2 multipurpose lithium grease or equivalent.
5. Reassemble hub and bearings.
  - a. Press oil seal very lightly against the shoulder on

the spindle.

- b. Press cups against the shoulder in the hub.
- c. Press sleeve to the shoulder in the hub.
- d. Place hub on shaft taking care not to damage the seal.
- e. Adjust the wheel bearing nut until there is a noticeable drag while turning the wheel. Do not back the nut off.
- f. Secure nut with a cotter pin.

## Pickup Teeth, Bands and Wear Strips

Check for bent, broken, or loose parts. If it is necessary to replace teeth or related parts, proceed as follows:

1. Ensure that pickup is blocked securely. Loosen the bolts, holding the band(s) on pickup. Slide band forward and remove the band from the bolts.
2. Should the plastic wear strips require removal and replacement, drill out or carefully grind off the “pop” rivets. Replace strip with new rivets.
3. Install new teeth or band(s). Use only the hardened washers supplied as original equipment from the manufacturer.

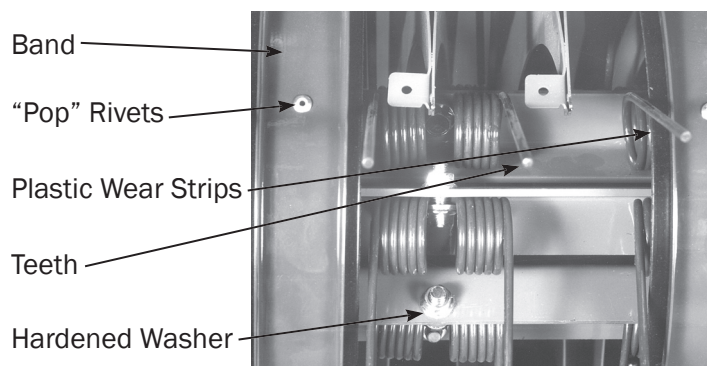
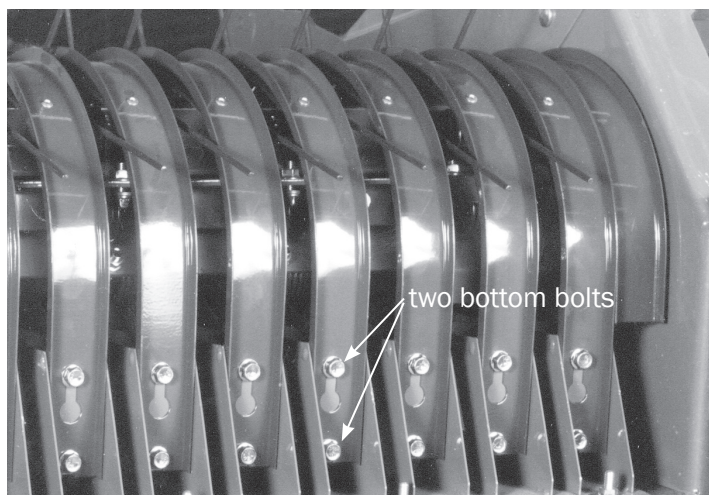

## Flotation Spring Adjustment

Set spring tension as follows:

Lower pickup to ground, attach a pull scale with a capacity of up to 100 lbs. (45 kg) to the wind guard crosstube. Correct tension on the scale should be approximately 50 lbs. (23 kg) in order to just begin to raise pickup. To lighten tension, loosen top nut (A) then turn bottom nut (B) counter clockwise until desired tension is reached. Turn nut (B) clockwise if more tension is needed.

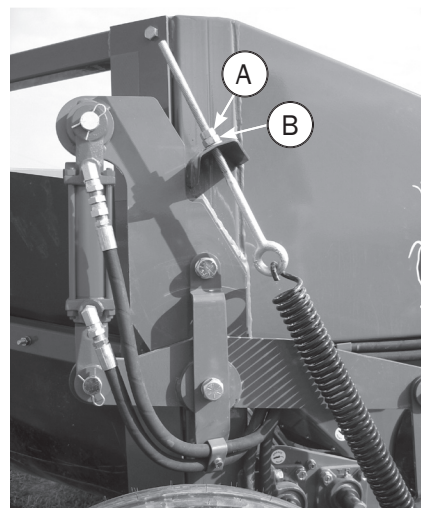



# Maintenance

## Inch Torque Chart for Bolts and Nuts

Standard Torque Requirements Foot-Pounds  
Use this chart as a guide when tightening bolts/nuts which do not have special torque requirements.

Bolt Diameter (inches)	Bolts		Locknuts	
	SAE Grade 5 Plated W/ZnCr	SAE Grade 8 Plated W/ZnCr	Grade B with GR5 Bolt	Grade C with GR8 Bolt
1/4	112*	157*	61*	86*
5/16	229*	324*	125*	176*
3/8	34	48	19	26
7/16	54	77	30	42
1/2	83	117	45	64
9/16	120	169	65	92
5/8	165	233	90	127
3/4	293	413	160	226
7/8	473	667	258	364
1	708	1000	386	545



**SAE Grade 5**

**SAE Grade 8**

\*Torque values are inch-pounds.

**Note:** For inch and metric bolts and nuts:

- These values are based on clean, dry threads. Reduce the value by 10% when a lubricant is used. Reduce the value by 20% if new plated bolts are used.
- Bolts threaded into aluminum must have two diameters of thread engagement and may require 30% more reduction in the torque.

## Metric Torque Chart for Bolts and Nuts

Standard Torque Requirements Foot-Pounds  
Use this chart as a guide when tightening bolts/nuts which do not have special torque requirements.

## Metric Bolt Markings & Torque Values

Metric bolts are identified by the grade number stamped on the head of the bolt or on the surface of metric nuts. The higher the number, the greater the strength of the bolt.

Bolt Diameter	Grade 8.8	Grade 10.9
6mm	60*	108*
7mm	108*	168*
8mm	18	23
10mm	30	45
12mm	55	75
14mm	85	120
16mm	130	175
18mm	170	240



\*Torque values are inch-pounds.

## General Information

A NLGI No. 2 multi-purpose high temperature lithium base grease is recommended.

Use a manual grease gun for all greasing. Air powered grease guns may damage the seal on the bearings.

Wipe all grease fittings with a clean cloth before greasing to avoid injecting dirt or grit in the bearings.

## Every 8 Hours of Use

Coat hydraulic motor coupler and chain with chain lubricant to prevent rust and seizing, Figure 1.

Grease bushing of gauge wheels, Figure 5.

## Every 100 Hours of Use or At The Beginning of The Season

Grease the sealed bearings on the pickup shaft, Figure 2 (two locations), front roller (two locations), and rear roller (four locations), Figure 4.

Clean, repack, and adjust wheel bearings. Grease gauge wheel bushings, just enough to force out moisture, Figure 5.

Figure 1

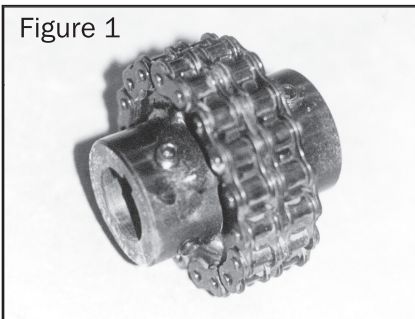

Figure 2

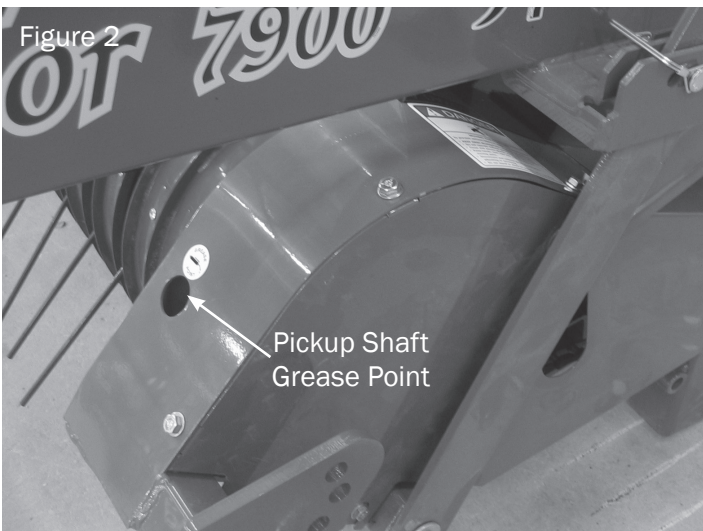

Figure 3

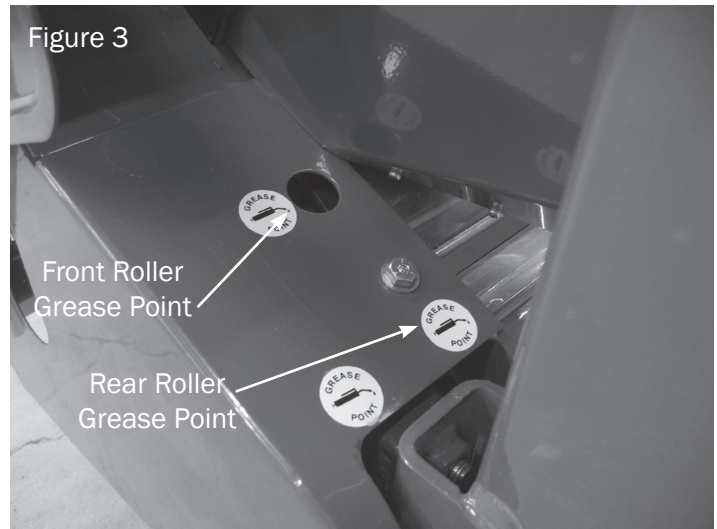

Figure 4

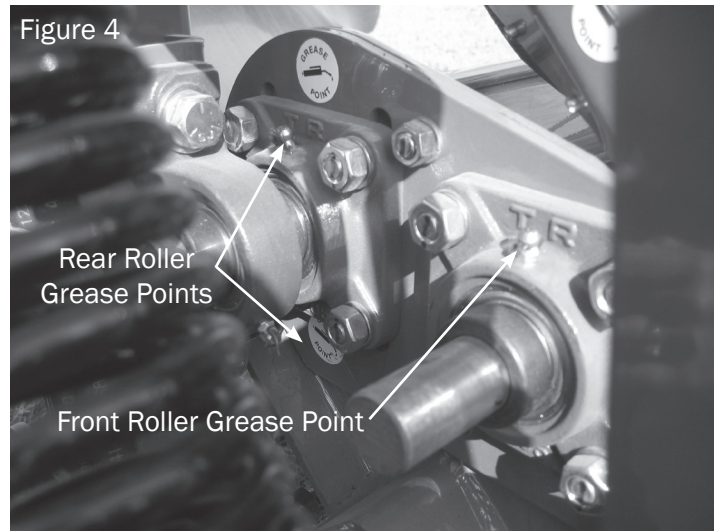
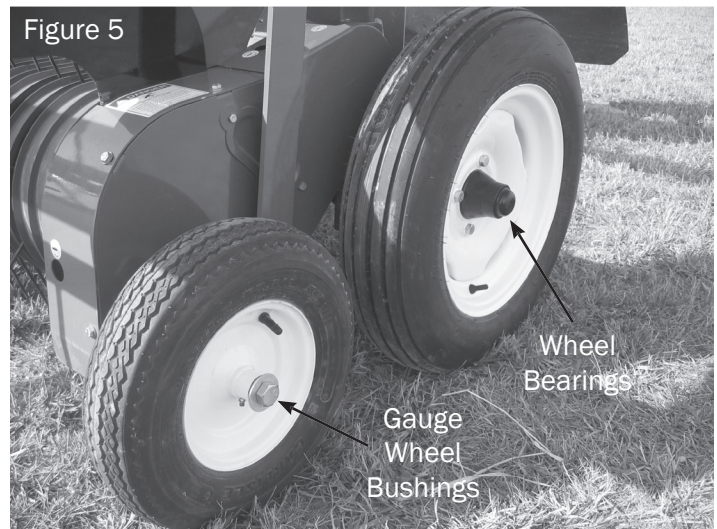
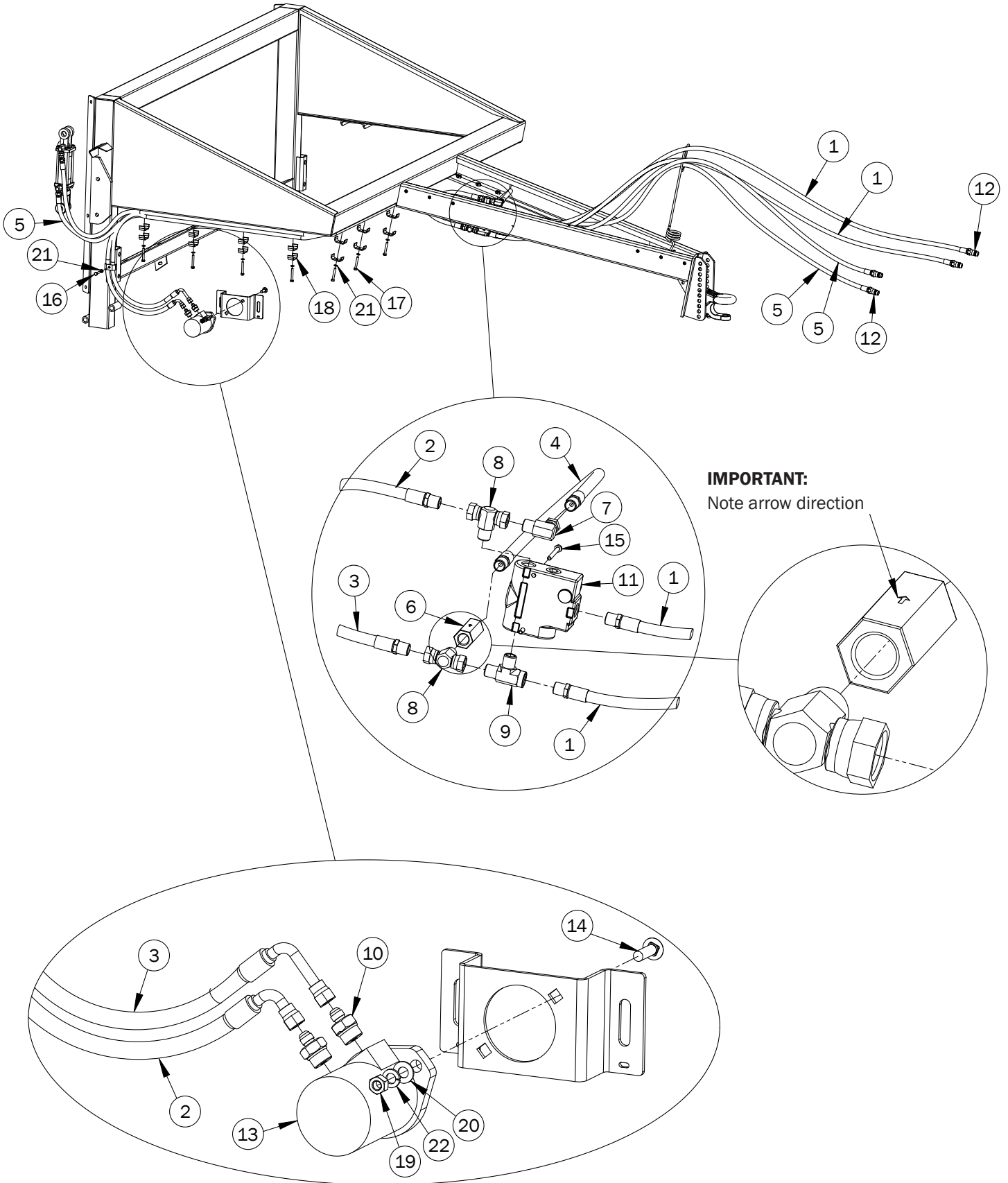

Figure 5



# Hydraulics Assembly Instructions



# Hydraulics Assembly Instructions

Item No.	Stock No.	Description	Qty.
1	802475	Hydraulic Hose, 94"	2
2	802476	Hydraulic Hose, 123"	1
3	802477	Hydraulic Hose, 117"	1
4	802478	Hydraulic Hose, 24"	1
5	802479	Hydraulic Hose, 198"	2
6	802474	Valve, Check	1
7	802482	Elbow, Hydraulic	1
8	802484	Tee, Hydraulic	2
9	802485	Tee, Hydraulic	1
10	802486	Adapter, Hydraulic	2
11	802836	Valve Body	1
12	804099	Quick Coupler	4
13	808787	Motor, Hydraulic, 2005 DH 160	1
14	800072	7/16" x 1-1/2" Bolt, Carriage	2
15	800183	1/4" x 2-1/2" Bolt, Standard	2
16	800205	5/16" x 1-1/2" Bolt, Standard	1
17	800208	5/16" x 2-1/4" Bolt, Standard	7
18	803829	Hydraulic Hose Clamp	15
19	800240	7/16" Nut, Standard	2
20	807799	7/16" SAE Washer, Flat	2
21	807528	5/16" Washer, Lock	8
22	806556	7/16" Washer, Lock	2

## Troubleshooting

Problem	Possible Cause	Solution
Hydraulic motor surging.	<ul style="list-style-type: none"> <li>▪ Flow controls improperly adjusted.</li> </ul>	<ul style="list-style-type: none"> <li>▪ Refer to Hydraulic Motor Speed Setting in Field Setup section.</li> </ul>
Pickup speed too slow.	<ul style="list-style-type: none"> <li>▪ Insufficient oil supply from tractor.</li> </ul>	<ul style="list-style-type: none"> <li>▪ Ensure tractor supplies oil as per tractor specifications.</li> </ul>
Leaking hydraulic motor.	<ul style="list-style-type: none"> <li>▪ Seal worn or damaged.</li> <li>▪ Seal ruptured by over pressure.</li> <li>▪ Contaminant damage to motor.</li> </ul>	<ul style="list-style-type: none"> <li>▪ Replace seal.</li> <li>▪ Replace seal.</li> <li>▪ Repair, ensure oil supply is clean.</li> </ul>
Pickup plugging or not allowing material to flow freely.	<ul style="list-style-type: none"> <li>▪ Feeding large windrow too rapidly.</li> <li>▪ Crop hold down fingers set too tightly.</li> <li>▪ Plastic tube over fingers worn or missing.</li> </ul>	<ul style="list-style-type: none"> <li>▪ Reduce ground speed.</li> <li>▪ Adjust.</li> <li>▪ Replace tube(s).</li> </ul>
Excessive noise from chain and sprockets.	<ul style="list-style-type: none"> <li>▪ Chain or sprockets worn.</li> <li>▪ Incorrect tension on chain.</li> <li>▪ Chain dry or rusted.</li> </ul>	<ul style="list-style-type: none"> <li>▪ Replace parts as needed.</li> <li>▪ Adjust as per Maintenance section.</li> <li>▪ Use proper lubrication on chain.</li> </ul>
Pickup is skipping swath or not picking cleanly.	<ul style="list-style-type: none"> <li>▪ Missing or broken pickup teeth.</li> <li>▪ Flotation spring adjusted too light.</li> <li>▪ Driving too fast.</li> <li>▪ Pickup tooth height too high.</li> </ul>	<ul style="list-style-type: none"> <li>▪ Replace teeth.</li> <li>▪ Adjust flotation.</li> <li>▪ Reduce ground speed.</li> <li>▪ Adjust gauge wheels to lower.</li> </ul>
Breakage or bending of pickup teeth.	<ul style="list-style-type: none"> <li>▪ Running pickup too low.</li> <li>▪ Pickup flotation set too heavy.</li> <li>▪ Excessive pickup rotation speed in rough or rocky conditions.</li> </ul>	<ul style="list-style-type: none"> <li>▪ Adjust gauge wheel height.</li> <li>▪ Adjust flotation.</li> <li>▪ Reduce pickup speed and/or ground speed.</li> </ul>
Material wrapping in pickup.	<ul style="list-style-type: none"> <li>▪ Nylon wear plate inserts missing or worn.</li> <li>▪ Hay too wet or tough.</li> <li>▪ Crop hold down set too tight.</li> <li>▪ Plastic tube over fingers worn or missing.</li> <li>▪ Pickup and/or travel speed not matched to crop conditions.</li> <li>▪ Flotation of pickup too light for rough field and excessive speed.</li> </ul>	<ul style="list-style-type: none"> <li>▪ Replace wear plates.</li> <li>▪ Allow to dry down sufficiently for proper operation.</li> <li>▪ Adjust.</li> <li>▪ Replace tubes.</li> <li>▪ Adjust speed to suit conditions.</li> <li>▪ Slow the travel speed to prevent pickup bouncing on swath.</li> </ul>
Material wrapping on rollers.	<ul style="list-style-type: none"> <li>▪ Pickup and/or travel speed not matched to crop conditions.</li> <li>▪ Crop hold down set too tight.</li> <li>▪ Worn or missing plastic tubes.</li> <li>▪ Hay too wet or tough.</li> </ul>	<ul style="list-style-type: none"> <li>▪ Adjust speed to suit conditions.</li> <li>▪ Adjust.</li> <li>▪ Replace tubes.</li> <li>▪ Allow to dry down sufficiently for proper operation.</li> </ul>



Problem	Possible Cause	Solution
Swath not being inverted completely.	<ul style="list-style-type: none"> <li>▪ Swath too wide.</li>   <li>▪ Rear of moldboard too high.</li>   <li>▪ Material being inverted is very fine.</li>   <li>▪ Windy conditions causing swath to be blown back to original position.</li> </ul>	<ul style="list-style-type: none"> <li>▪ Narrow the width of swath laid down by cutting unit to between 3' to 4' (.9 m to 1.2 m) maximum.</li> <li>▪ Increase the field and travel speed, where possible, to ensure maximum swath travel.</li> <li>▪ Level moldboard frame so it is parallel to ground.</li> <li>▪ Lower rear of moldboard to slightly lower than level by raising the hitch.</li> <li>▪ Crowd material more to right side of pickup.</li> <li>▪ Ensure that swath to be inverted is no more than 9' (3 m) wide.</li> <li>▪ Invert swath only in conditions allowing proper results.</li> </ul>
Excessive leaf loss while inverting.	<ul style="list-style-type: none"> <li>▪ Swath excessively dried or bleached.</li> <li>▪ Pickup and/or travel speed too high.</li> </ul>	<ul style="list-style-type: none"> <li>▪ If speeds are adjusted correctly, minimal leaf loss is to be expected.</li> <li>▪ Adjust speed to suit condition.</li> </ul>

# LIMITED WARRANTY

## AGLAND INDUSTRIES INC. WARRANTY

AgLand Industries Inc. (hereinafter called "AgLand"), as the Manufacturer, warrants to the original owner of the AgLand Matador (hereinafter called the "Matador") the following:

A one (1) year\* warranty that the purchased Matador will be free of defects in material or workmanship and workmanship on all parts manufactured by AgLand, including AgLand manufactured owner-serviceable parts (provided such parts are serviced in accordance with the Operator's Manual), from the date of delivery to the original retail purchaser under normal farm use and service, excluding normal wear items such as (but not limited to) chains, pickup tines, tires, and exterior finish.

\*Three (3) months after delivery when purchased by a commercial operator.

The sole obligation of the Manufacturer is limited to repairing or replacing, as the Manufacturer may elect, any part or parts that prove, in the Manufacturer's judgement, to be defective in material or workmanship.

Warranty service may only be performed by an authorized AgLand Dealer or an authorized AgLand Service Centre or as determined by AgLand.

Defective parts must be returned to the Manufacturer or the AgLand Dealer who sold the Matador at the expense of the retail purchaser and are to be inspected by the Manufacturer prior to any warranty work being approved. The AgLand Dealer will forward, at the retail purchaser's expense, any defective parts to AgLand with a written request of warranty work required.

Note: All parts NOT manufactured by AgLand carry their own manufacturer's warranty. The customer is responsible for all costs necessary to replace those parts unless covered by the applicable manufacturer.

The above warranty is based on the following factors:

AgLand reserves the right to repair or replace, at its discretion, any defective part in whole or in part.

All instructions in the AgLand Matador Operator's Manual must be followed.

The Warranty Registration must be forwarded to AgLand within thirty (30) days of the date of delivery of the Matador to the Retail Purchaser to validate the warranty.

All warranties are subject to legislation of the state or province in which the Matador is sold.

AgLand will not be responsible or liable for any of the following:

a) The return of any part or parts, or the Matador as a whole, to the selling AgLand Dealer or to the Manufacturer, neither AgLand or its authorized AgLand Dealer are responsible for the cost of shipping, transport, freight, labour, or any cost other than the warranted replacement part itself; b) The care, maintenance and safe operation of the Matador, which is the responsibility of the owner of the Matador; c) Any accidents, injury, damage or loss incurred due to use by any operator of the Matador; d) Any accidents, injury, damage or loss incurred due to faulty use, repair, operation or maintenance of the Matador; e) Any cost incurred for replacing or repairing of parts not manufactured by AgLand which carry their own manufacturer's warranty; f) Any out-of-pocket expenses or loss of revenue as a result of any defect in material or workmanship of any part or parts, or the Matador as a whole; g) Damages, malfunctions or failures resulting from the use of any attachment not authorized by AgLand; h) Any accidents, injury, damages, or loss incurred due to any safety shields, lights, reflectors, decals, emblems, etc., being removed or covered; i) Any accidents, injury, damage or loss due to the

improper, or lack of, use of the safety tow chain or transport lock pin during transport; j) Any accidents, injury, damage or loss due to the lack of safety precautions when performing routine maintenance; k) Damages, malfunctions or failures caused by force majeure, abuse, accident, fire, or acts of God; l) All customers outside of North America are responsible for compliance with local laws, codes and regulations regarding operating requirements and certification, as well as all costs associated with such requirements and certification.

Any available warranty will be void if: a) Annual maintenance procedures are not followed as per the Operator's Manual; b) Any altering or modification is performed on the Matador which is not approved by the Manufacturer; c) Any additional equipment is installed on the Matador which has not been approved by the Manufacturer; d) Any instruction given in the Operator's Manual which has not been followed including during set up or assembly of attachments, or regular maintenance; or e) Any claim made under this warranty by, or for, a person other than the original owner.

There are no other warranties, expressed or implied, by AgLand or its Authorized AgLand Matador Dealers regarding the AgLand Matador except the warranty expressed herein. ANY IMPLIED WARRANTIES, INCLUDING MERCHANTABILITY, OR FITNESS FOR A PARTICULAR PURPOSE, SHALL NOT EXTEND BEYOND THE APPLICABLE WARRANTY PERIODS SPECIFIED ABOVE. AGLAND'S SOLE LIABILITY, WITH RESPECT TO ANY DEFECT, SHALL BE AS SET FORTH IN THIS LIMITED WARRANTY, AND ANY CLAIMS FOR INCIDENTAL OR CONSEQUENTIAL DAMAGES ARE EXCLUDED.

No person is authorized to bind AgLand to any other warranty whatsoever.

AgLand reserves the right at any time to make changes or improvements to the design, materials, or specifications of the Matador or parts without thereby becoming liable to make similar changes to the Matador or any of its parts previously manufactured.

Manufactured by:

AgLand Industries Inc.

