



Operator's Manual
March 2008



AgLand
INDUSTRIES INC.

Replacement Parts

To obtain prompt, efficient service, give the dealer the following information.

1. Correct stock number.
2. Model number of the machine.
3. Serial number of the machine.

The serial number is important in identifying your machine. It contains information for ordering replacement parts and options which may vary depending on the serial number identification.

Measurements are given in U.S. units followed by the equivalent in metric units. Hardware sizes are given in inches for the U.S. hardware and millimeters for the metric hardware.

All nuts and bolts are specified in Grade 5 unless otherwise specified.

AgLand	
Box 479 Arborg MB, R0C 0A0	
Model #:	Macerator 6610
Serial #:	
Made in Canada	

Serial # on plate inside right side cover.

Warranty Registration Form	3
Introduction.....	5
Safety.....	6-7
Transport Safety	6
Operating Safety.....	7
Hydraulic Safety.....	7
Air Safety.....	7
Safety Decals	8
Specifications	9
Assembly	10
Assembly (Attachments)	11-13
Moldboard Merger.....	11
Spreader	12
Windrower	13
Tedder	14-15
Tedder Hydraulics.....	16-17
Field Setup	18-19
PTO Speed	18
Pickup Height and Adjustment	18
Steel Roll Adjustment.....	18
Preparation (Air System)	19
Rubber Roll Pressure Adjustment	19
Steel Roll Pressure Adjustment.....	19
Maintenance	20-23
Checklist	20
Roll Drive Belt Replacement.....	21
Bearing Replacement	22
Replacing or Repacking Wheel Bearings.....	22
Pickup Teeth, Wrappers, and Wear Strips	22
Inch Torque Chart for Bolts and Nuts.....	23
Metric Torque Chart for Bolts and Nuts	23
Lubrication	24
Belts.....	25
Optional Kits.....	26
Troubleshooting	27
Warranty	Back Cover

Congratulations, you have just purchased the new and improved AgLand Macerator 6610. To get the maximum benefit from your Macerator we suggest that you read this manual carefully.



The Macerator is designed to condition the hay for a super fast dry down while maintaining the maximum amount of nutrients and color. The Macerator utilizes special steel rolls, each running at a different speed allowing for a measured nicking of the stem for greater air exposure. The low profile, heavy duty pickup allows for rapid operation with minimal leaf loss.

The roll system of the Macerator is designed to allow for the right amount of maceration without cutting up the hay.

These operating and maintenance instructions have been compiled from extensive field experience and engineering data. Some information is general in nature due to unknown and varying conditions. However, through experience and these instructions, you will be able to develop operating procedures suitable to your particular situation.

Please study this manual from the beginning to end BEFORE operating your new Macerator 6610. Pay special attention to the Safety section in this manual and the safety cautions on your equipment. Should anyone else operate this equipment be sure that they understand ALL safety, operating, and maintenance information presented in this manual.

The terms 'right' and 'left', as used throughout this manual, are determined by facing the direction the machine will travel when in use.

The photographs, illustrations, and data used in this manual were current at the time of printing, but due to possible inline production changes, your machine can vary slightly in detail. The Manufacturer reserves the right to redesign and change the machine as necessary without notification.

WARNING

Some pictures in this manual show the machine with shields removed to allow for a better view of the subject. The machine must never be operated with any of the shields removed.

AgLand Industries Inc. is a Canadian owned and operated company located in central Canada, in the province of Manitoba. AgLand was founded in 2001 by a group of innovative entrepreneurs that transformed their ideas and expertise into a leading manufacturing company of agricultural crop equipment.

Box 479 Arborg MB, Canada ROC OAO

Tel: 204.364.2211

Fax: 204.364.2472

Email: sales@aglandindustries.com

Web: www.aglandindustries.com



Safety

Read this manual completely and understand all operating instructions and precautions BEFORE attempting to operate or service your machine.

The safety information given in this manual does not replace safety codes, insurance needs, or state/province and local laws. Make sure your machine has the correct equipment needed as specified by the local laws and regulations.

Understand that your safety and the safety of other persons is measured by how you service and operate this machine.

IMPORTANT! Review and understand the positions and functions of all machine controls before operating this machine.

WARNING! Do NOT attempt any adjustments, maintenance, trouble shooting, or repairs while machine components are moving or activated with pressure.

- Lower machine to ground or onto appropriate blocks.
- Stop tractor engine and remove ignition key.
- Set tractor parking brake prior to leaving operator station.

Safety Alert Symbol



The Safety Alert symbol identifies important safety messages in the manual and on the machine. When you see this symbol, be alert to the possibility of personal injury or death. Follow all the instructions in the safety message given. This symbol means attention, be alert, and your safety is involved.

Three Reasons To Follow Safety Instructions:

1. Accidents disable and kill.
2. Accidents cost.
3. Accidents can be avoided.

Slow Moving Vehicle Emblem



The Slow Moving Vehicle (SMV) emblem must be placed on the rear of the machine and be visible to traffic approaching the machine from the rear while traveling on public roads. Keep the SMV emblem clean and replace when damaged or emblem materials have faded. The SMV should only be displayed on the machine at road speeds less than 40 km/hr (25 MPH).

Signal Words

DANGER

DANGER: Indicates an imminently hazardous situation that, if not avoided, WILL result in death or serious injury if proper precautions are not taken.

WARNING

WARNING: Indicates a potentially hazardous situation that, if not avoided, COULD result in death or serious injury if proper precautions are not taken.

CAUTION

CAUTION: Indicates a potentially hazardous situation that, if not avoided, MAY result in minor or moderate injury if proper practices are not taken, or serves as a reminder to follow appropriate safety practices.

Transport Safety

- The operator is responsible for complying with all local regulations regarding transporting agricultural equipment on public roads.
- Ensure all lights and reflectors, as required by local law, are in place, intact, and clean before transporting machine on public roads.
- Connect electrical socket on machine wiring harness to tractor receptacle.
- Ensure SMV emblem is clean and properly displayed, where required by law, before transporting machine on public roads.
- Do NOT allow riders on machine at any time including transport of machine on public roads.
- Maximum transport speed is 32 km/hr (20 MPH). Reduce speed on rough roads and surfaces.
- Use proper retainer on drawbar hitch pin and attach safety tow chain to tractor prior to transporting machine on public roads.
- Ensure that transport lock pin is installed and secured in the hole provided for transport.
- Tractor light switches should be set for road transport. Refer to tractor operator's manual for information.



Hitch and safety chain.

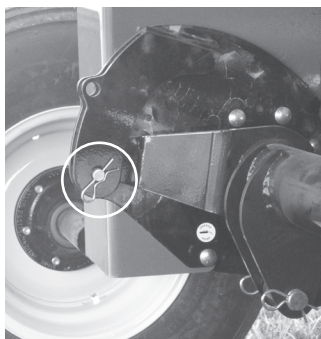

Lock travel pin in place.

Operating Safety

- REVIEW ALL SAFETY INSTRUCTIONS with all operators before allowing them to operate the equipment. Review instructions at least once each year.
- All shields and guards must be intact and in position and securely fastened before operating the Macerator.
- Only use a tractor equipped with ROPS cab and seat belt. Be careful when operating close to a road or building, the machine can throw stones and other objects during operation.
- Emphasize the importance of safety when working around and operating the machine.
- Do NOT allow riders on any part of the equipment at any time.
- Always keep hands, feet, and clothing away from moving parts.
- Always lower the Macerator to the ground when parking.
- Use transport lock pin and retainer to secure the lift linkage of the Macerator before transporting equipment.
- Use safety tow chain at all times.
- NEVER attempt to unplug the machine when the tractor is running and hydraulic system is pressurized.
- Keep hands, feet, and clothing away from the pickup area when in operation to avoid entanglement hazards. Do not open or remove shields or guards while machine is running.
- Relieve all pressure from hydraulic lines before disconnecting them. Before applying pressure to the system, make sure all connections are tight and that hoses and lines have not been damaged.

Hydraulic Safety

- Ensure that all components in the hydraulic system are kept in good condition.
- Replace any worn, cut, abraded, flattened, or crimped hoses and/or metal lines.
- Do not attempt any poorly executed repairs to hydraulic lines, fittings, or hoses by using tape, clamps, or cements. The hydraulic system operates under extremely high pressure: 11,033 to 15,859 kPa (1600 to 2300 PSI). Such repair will fail suddenly and create unsafe conditions.
- Wear proper hand and face protection (e.g. face shield) when searching for a high pressure hydraulic leak. Use a piece of wood or cardboard as a backdrop instead of hands. A high pressure concentrated stream of hydraulic fluid can pierce the skin. If such happens, seek immediate medical attention as infection and toxic reaction could develop.
- Before applying hydraulic pressure to the system, make sure all connections are tight and that lines, hoses, and couplings are not damaged.

Air Safety

- Make sure all hoses and bellows are kept in good condition and are clean.
- Replace any damaged lines or bellows.
- Do not exceed 827 kPa (120 PSI) air pressure in tank and 689 kPa (100 PSI) in air bags.

**Think Safety,
Work Safely!**

Manual Storage Container

Keep the Operator's Manual in the storage container provided on the Macerator. The Operator's Manual must be available for use by all operators.



Safety Decals

Moving Parts Hazard

! DANGER!



MOVING PARTS HAZARD

To prevent serious injury or death from moving parts:

- KEEP AWAY, Moving Parts can crush and dismember.
- Do not operate without guards and shields in place.
- Close and secure guards and shields before starting.
- Keep hands, feet, hair, and clothing away from moving parts.
- Disconnect and lockout power source before adjusting or servicing.
- Do not stand or climb on machine when operating.

DC0063

High Pressure Fluid Hazard

! WARNING!



HIGH PRESSURE FLUID HAZARD

To prevent serious injury or death:

- Relieve pressure on system before repairing, adjusting or disconnecting.
- Wear proper hand and eye protection when searching for leaks. Use wood or cardboard instead of hands.
- Keep all components in good repair.

DC0068

Keep Shields and Guards in Place

! DANGER!



KEEP SHIELDS AND GUARDS IN PLACE

DC0064

AgLand Macerator Model 6610

Dimensions

Overall Width	10'6" (315 cm)
Length	11'4" (345 cm)
Height	operation 3'6" (105 cm) transport 5'6" (165 cm)
Weight (with windrower)	4,334 lbs. (1,970 kg)

Tires (4)

Tire Size	11 L - 15 SL
Pressure	20 PSI (138 kPa)
Wheel Hub	6 bolt
Wheel Bolt Torque	85 ft. lbs. (115.2 NM)

Pickup

Width	5'6" (165 cm)
Clearance*	14" to 16" (35.5 cm to 40.5 cm)
Tooth Clearance**	10" to 12" (25 cm to 30 cm)
Pickup Tooth Spacing	2.75" (7 cm)

*Under pickup when raised.

**When raised.

Rolls

Width of rubber feed rolls	5'6" (165 cm)
RPM of rubber feed rolls	645 RPM
Min. space between rubber rolls	1/32" (0.8 mm)
Width of steel rolls	5'6" (165 cm)
RPM of top steel roll	1372 RPM
RPM of bottom steel roll	1514 RPM
Min. space between steel rolls	1/32" (.8 mm)

Tractor Requirements

Suggested tractor size*	Min. 80 HP - Max. 120 HP
Suggested min. under frame clearance**	15" (38 cm)

*Tractor should be of sufficient size to maintain operator control in all situations.

**To allow swath to flow freely under tractor.

Air System

Size of air pressure tank	12 Gallon (46 L)
Max. air pressure in tank	120 PSI

Hydraulic outlets required **1**

Operating Speed

Approximate range* 8 to 16 km/hr (5 to 10 MPH)

*Depending on crop conditions.

Swath Size

Width up to 5' (150 cm)

Cut Width

Recommended Width 14' to 16' (480 cm)

Capacity

Up to 5.0 ton/acre

Lubrication

NGLI No. 2 multi-purpose high temperature lithium base grease

Gear Box

SAE15W40 (Diesel) 2.5 L

Some weights and measurements are approximate.

All specifications, statements, and information shown in this manual are believed to be accurate at the time of printing. Specifications are subject to change without notice.

Assembly

Attaching Hitch

Sometimes the hitch will be shipped detached from the unit to allow for a more compact shipping package.

1. Bolt hitch to main frame, Figure 1, using fourteen 5/8" x 1 1/2" carriage bolts. Be sure bolts are securely tightened all around.
2. Remove bearing on front of hitch (C), slide drive shaft (B) onto override clutch (A) through front bearing hole and reinstall bearing and tighten shaft bolts on override clutch (A).
3. Install the long hydraulic hose (G) securely with the clamps (F) provided, as shown in Figure 2.
4. Torque required on 5/8" bolt for overriding clutch (A) is 65 ft.-lbs.

- A. Override Clutch
- B. Drive Shaft
- C. Front Hitch Bearing
- D. A Frame Cover (Back)
- E. A Frame Cover (Front)
- F. Hose Clamp
- G. Long Hydraulic Hose

Figure 1

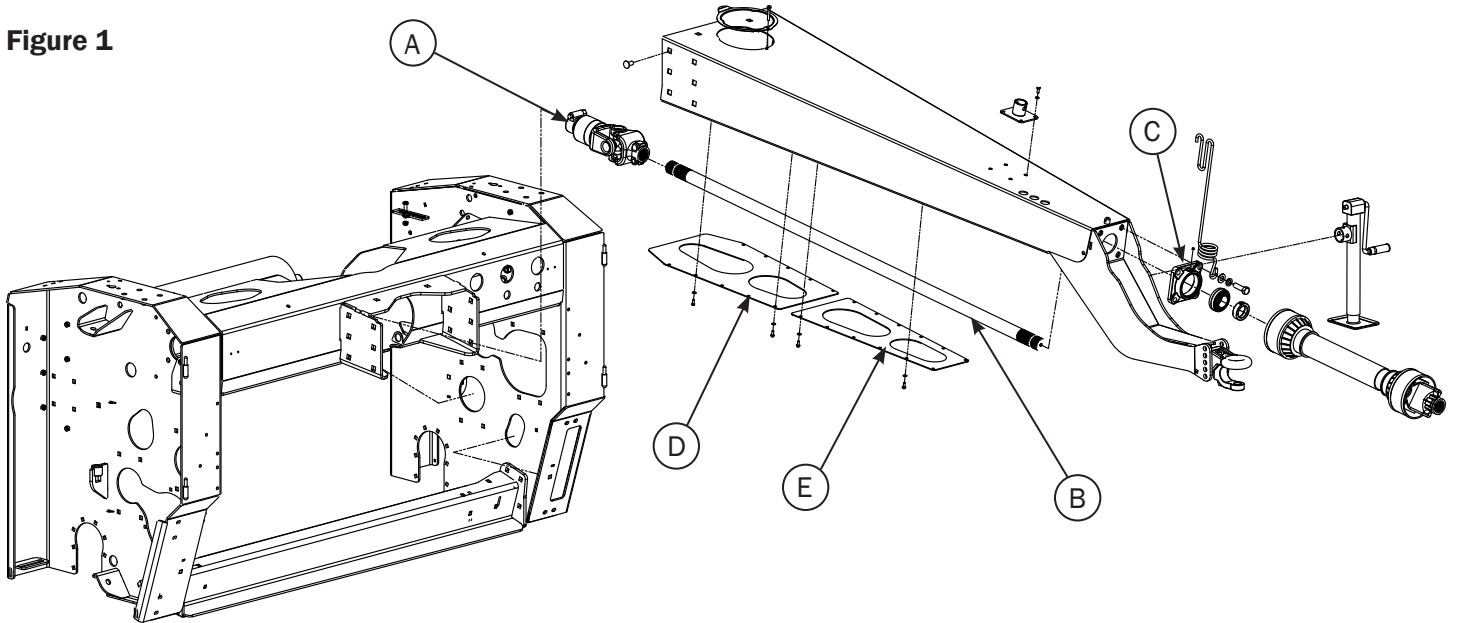
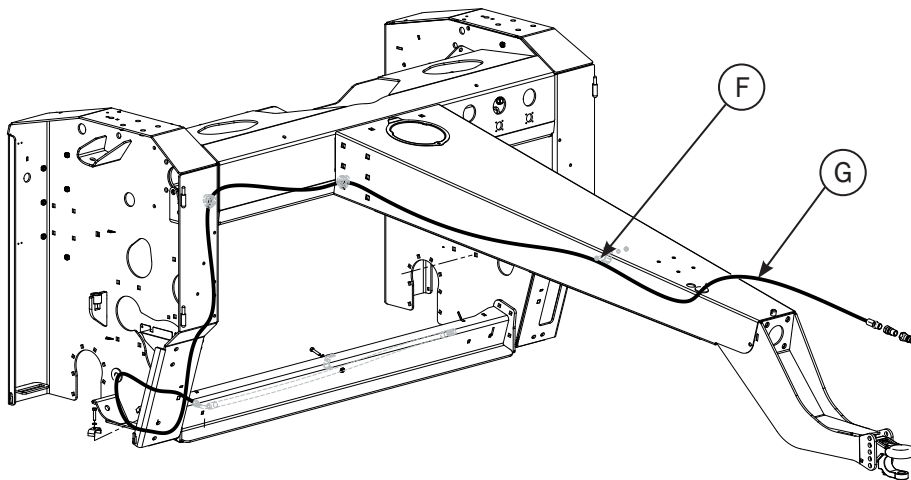

Figure 2



Moldboard Merger

1. Attach moldboard attachment bracket L/H (A) to the moldboard main frame (B) and attach main frame to quick attach bracket (C - already installed) and insert lynch pin (N).
2. Attach moldboard attachment bracket R/H (E) to the adjustment bar (D) and attach bar to bracket (F - already installed) and insert lynch pin (N).
3. Attach small frame (G) to the main frame (B), using $1/2" \times 1 1/2"$ hex bolts with bushing, washer, lock washer, and hex nut.
4. Attach extension adjustment bar (H) to small frame (G) using $1/2" \times 1 1/2"$ standard bolt, bushing, washer, lock washer and standard nut and insert adjuster pin (J).
5. Slide main frame adjustment bracket (D) through the adjustment bar (E) and insert $1/2" \times 3"$ pin (K).

Moldboard Sheet Installation

6. Install short moldboard (L) to outside portion of small frame (G) using $5/16" \times 3/4"$ carriage bolts and hex nuts.
7. Install longer moldboard sheet (M) on to the main frame (B) using $5/16" \times 3/4"$ carriage bolts, overlapping the short moldboard sheet.
8. All bolts holding the moldboard sheets can now be fully tightened.
9. Adjust angle of moldboard by moving adjustment bracket (E) in or out of adjustment bar (D) to preferred moldboard angle and insert $1/2" \times 3-1/2"$ pin. The tighter angle will result in less inversion. The wider angle will give you a greater inversion.

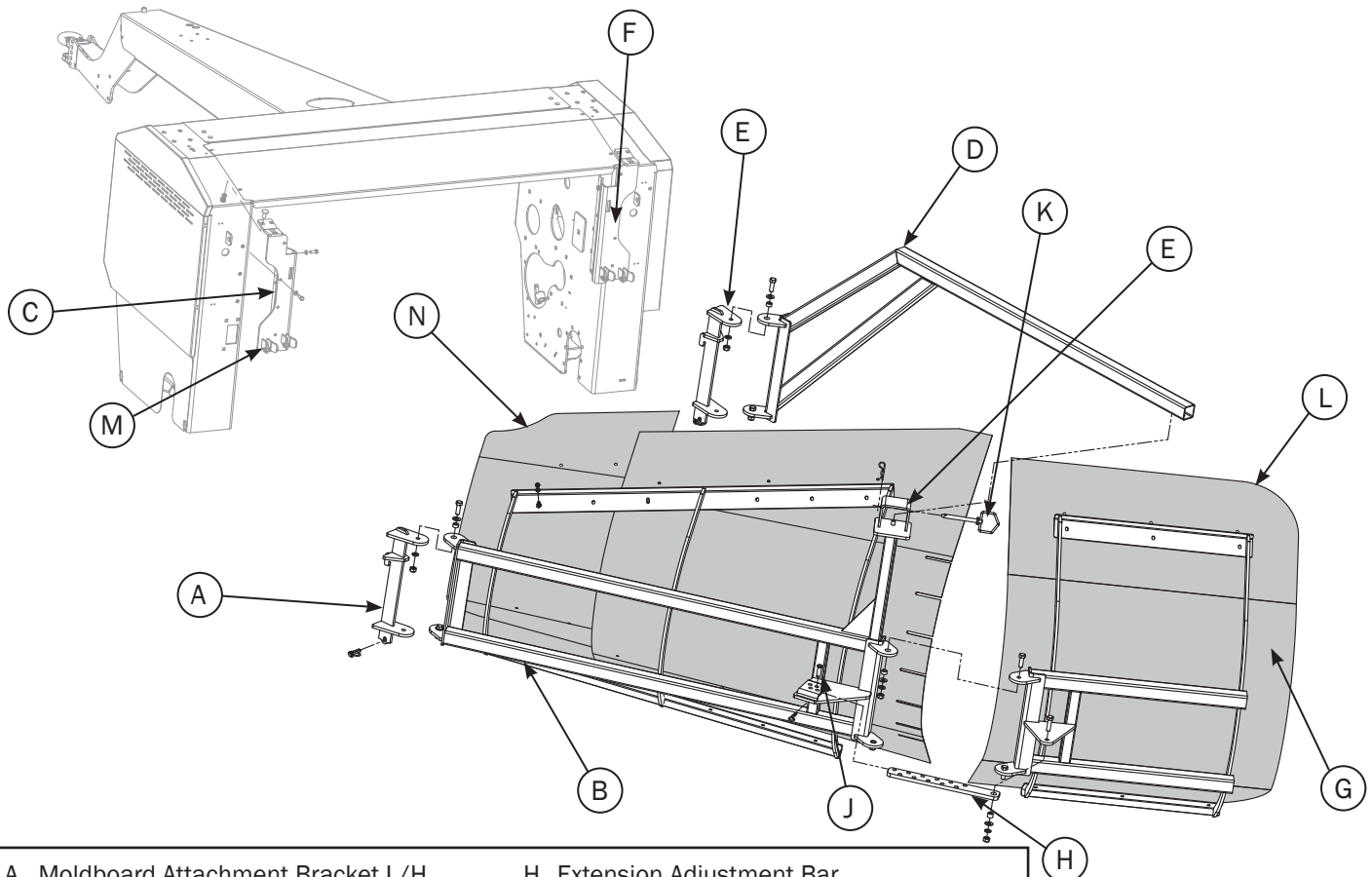

- | | |
|-------------------------------------|-----------------------------|
| A. Moldboard Attachment Bracket L/H | H. Extension Adjustment Bar |
| B. Moldboard Main Frame | J. Adjustment Pin |
| C. Quick Attach Bracket L/H | K. Pin |
| D. Adjustment Bar. | L. Short Moldboard Sheet |
| E. Moldboard Attachment Bracket R/H | M. Long Moldboard Sheet |
| F. Quick Attach Bracket R/H | N. Small Moldboard Sheet |
| G. Small Frame | O. Lynch Pin |

Moldboard Attachment

Assembly (Attachments)

Spreader Attachment

The spreader attachment allows the Macerator to spread a wider swath and leave a thinner layer on the field for greater sun and wind exposure.

The spreader attachment attaches onto the rear of the main frame.

1. Attach bracket (A) to the side panels (C and D) using $3/8"$ x $1\ 1/4"$ bolts with washer, lock washer, and nut.
2. Mount side panels (C and D) to top plate (B) with $5/16"$ x $3/4"$ bolts, washer, and lock washer.
3. Mount deflector fins (F) to top plate (B) using $3/8"$ x $3/4"$ bolts (G) and $3/8"$ x $3/4"$ bolts, washers, lock washers, and nuts (H).
4. Hook spreader attachment to the quick mounting brackets (E - on main frame) and insert lynch pin.

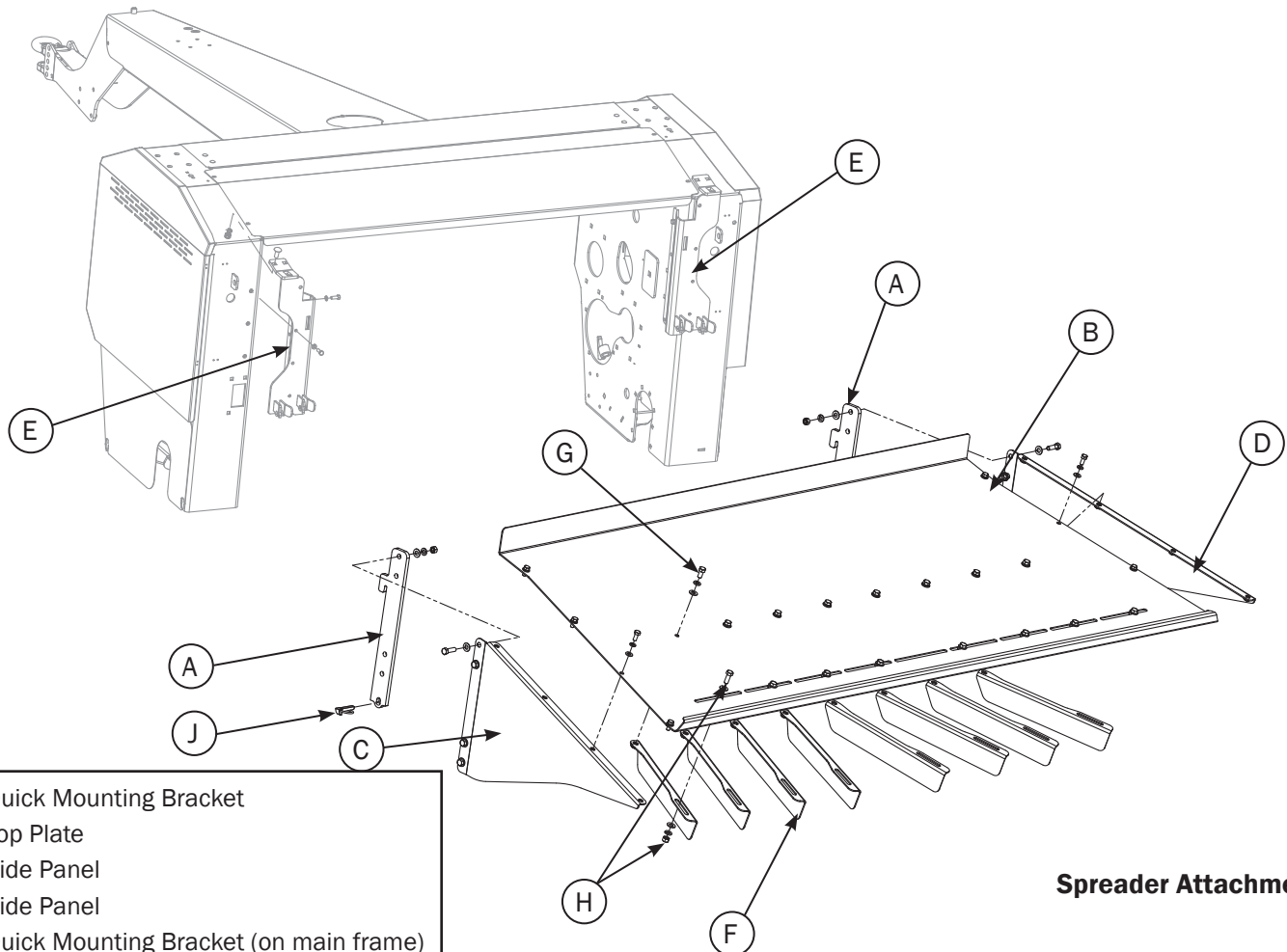

- A. Quick Mounting Bracket
- B. Top Plate
- C. Side Panel
- D. Side Panel
- E. Quick Mounting Bracket (on main frame)
- F. Deflector Fin
- G. Bolt
- H. Nuts and Washers
- J. Lynch Pins

Spreader Attachment

Windrower Attachment

The windrower attachment allows you to direct the cut hay down to keep a tighter windrow, or out for a wider swath width.

1. Insert 3/8" x 1 1/4" bolts through side panel (A) and attach quick mounting bracket (B).
2. Mount side panels (A and K) to top plate (G) with 5/16" x 3/4" bolts. Do not tighten bolts.
3. Mount side bracket (C) to panel (A) with 3/8" x 3/4" bolts. Only two bolts.
4. Insert windrow baffle (E) into hole of side bracket (C).
5. Mount the other side bracket (F) to side panel (K) with 3/8" x 3/4" bolts.
6. Mount adjustment bracket (H) using 5/16" x 1 1/2" socket head cap screws and wing bolts (D).
7. Install left and right side width adjusters (J and M) using 3/8" x 1" bolt and bushing (L) through top plate (G).
8. Insert wing bolt with washer (D) through slot into width adjusters (J and M).
9. Tighten all bolts evenly.
10. Hook spreader attachment to the quick mounting bracket on main frame and insert lynch pin (N).

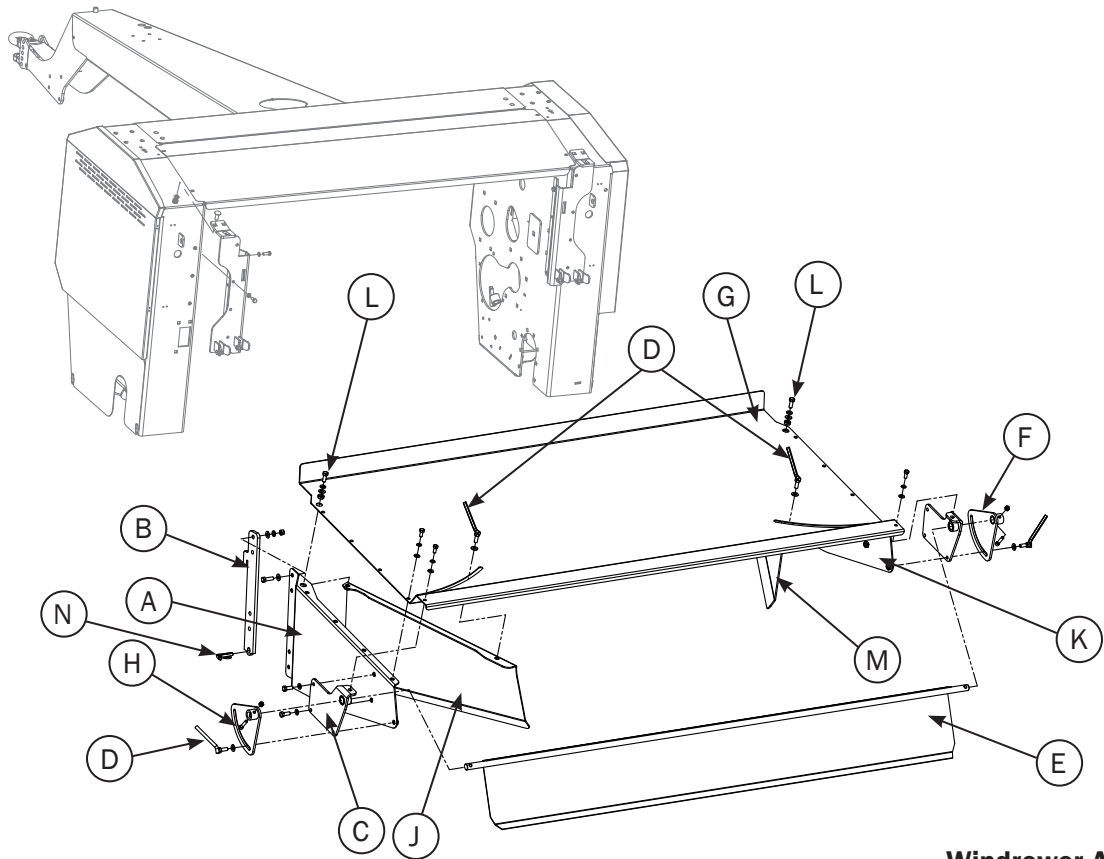

Windrower Attachment

- | | |
|---------------------------|-----------------------|
| A. Side Panel | H. Adjustment Bracket |
| B. Quick Mounting Bracket | J. Width Adjuster |
| C. Left Side Bracket | K. Side Panel |
| D. Wing Bolt | L. Bushing |
| E. Windrow Baffle | M. Width Adjuster |
| F. Right Side Bracket | N. Lynch Pin |
| G. Top Plate | |

Note:
Use supplied washers and nuts with described bolts above.

Assembly (Attachments)

Tedder Attachment

Item No.	Stock No.	Description	Qty.
1	800321	Coupler, 1-3/8"	1
2	801682	Tedder, Daros (Rossi)	1
3	801818	Pin, Lynch, 7/16"	2
4	801820	Pin, R, 1/8"	1

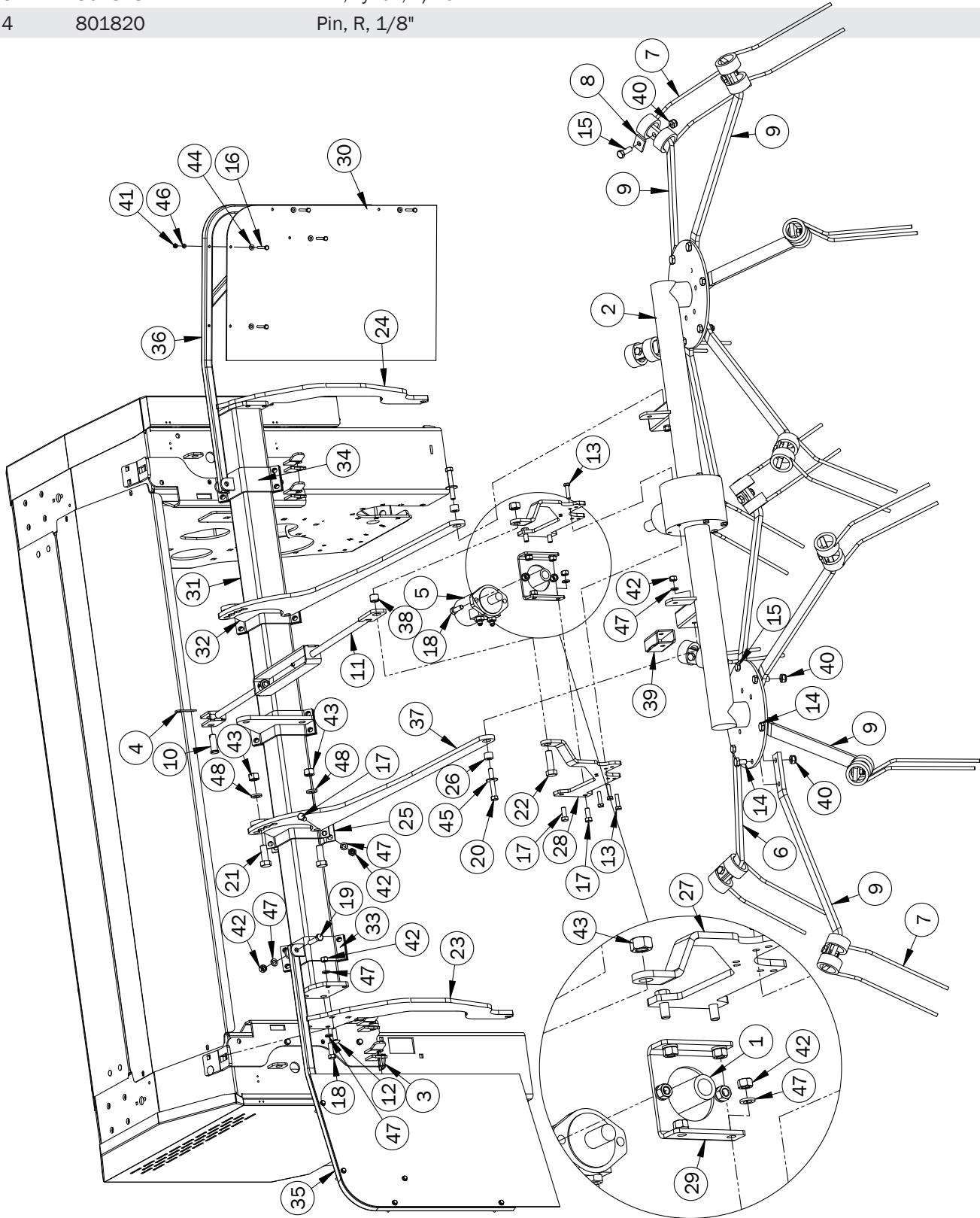

Tedder Attachment

Item No.	Stock No.	Description	Qty.
5	808545	Motor, Hydraulic, 2006 DH 50 (See pages 144-145, Item 11)	-
6	809090	Tooth Arm, Fixed, Tedder	8
7	809091	Tooth, Tedder	12
8	809092	Plate, Tooth Clamp, Tedder	12
9	809096	Tooth Arm, Adjustable, Tedder	4
10	809586	Pin, Clevis, 3/4" x 2"	1
11	810158	Turnbuckle Assembly, Tedder (See pages 146-147)	1
12	800054	1/2" x 1-1/2" Bolt, Carr.	4
13	809040	10mm x 40mm Bolt, Metric	6
14	809098	14mm x 25mm Bolt, Metric	4
15	809094	14mm x 40mm Bolt, Metric	20
16	800182	1/4" x 2" Bolt, Standard	10
17	800166	1/2" x 1-1/4" Bolt, Standard	24
18	800165	1/2" x 1-1/2" Bolt, Standard	6
19	808784	1/2" x 2-1/4" Bolt, Standard, Gr. 8	2
20	800174	1/2" x 3-1/2" Bolt, Standard	2
21	800190	3/4" x 2" Bolt, Standard	4
22	800191	3/4" x 2-1/2" Bolt, Standard	1
23	810553	Tedder Attachment Hook, L/H	1
24	810555	Tedder Attachment Hook, R/H	1
25	808174	Tedder Clamp	5
26	808172	Tedder Attachment Arm Spacer	2
27	807861	Arm, Motor Mounting, R/H	1
28	807864	Arm, Motor Mounting, L/H	1
29	807859	Motor Mounting Plate	1
30	807882	Tedder Flap	2
31	807876	Tedder Main Beam	1
32	807844	Tedder Attachment Bracket	3
33	807854	Tedder Flap Attachment Bracket, L/H	1
34	807857	Tedder Flap Attachment Bracket, R/H	1
35	810559	Tedder Flap Frame, L/H	1
36	810562	Tedder Flap Frame, R/H	1
37	810557	Tedder Attachment Arm	2
38	810157	Bushing, Turnbuckle, Tedder	1
39	810566	Tube, Tedder Arm	2
40	809095	14mm Nut, Nylon Lock	24
41	800233	1/4" Nut, Standard	10
42	804196	1/2" Nut, Standard	34
43	804199	3/4" Nut, Standard	5
44	808781	1/4" SAE Washer, Flat	10
45	804364	1/2" Washer, Flat	2
46	808353	1/4" Washer, Lock	10
47	804367	1/2" Washer, Lock	38
48	804369	3/4" Washer, Lock	4

Assembly (Attachments)

Tedder Attachment Hydraulics

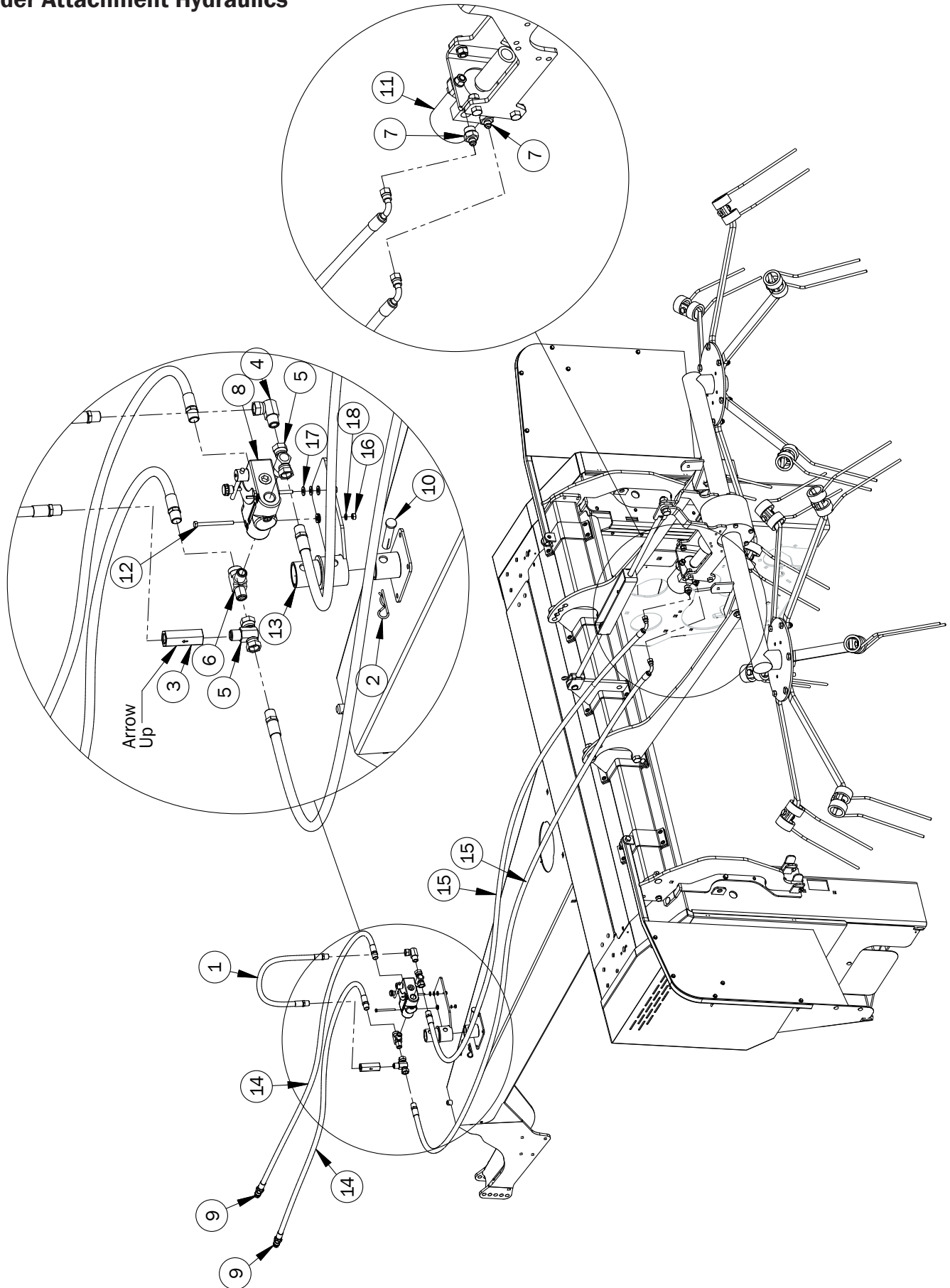

Tedder Attachment Hydraulics

Item No.	Stock No.	Description	Qty.
1	802478	Hydraulic Hose, 24"	1
2	801820	Pin, R, 1/8"	1
3	802474	Valve, Check	1
4	802482	Elbow, Hydraulic	1
5	802484	Tee, Hydraulic	2
6	802485	Tee, Hydraulic	1
7	802486	Adapter, Hydraulic	2
8	802836	Valve Body	1
9	804099	Quick Coupler	2
10	807055	Pin, Clevis	1
11	808545	Motor, Hydraulic, 2001 DH 50	1
12	808783	1/4" x 3" Bolt, Standard	2
13	807879	Valve Body Holder	1
14	808721	Hydraulic Hose	2
15	808722	Hydraulic Hose	2
16	800233	1/4" Nut, Standard	2
17	807522	5/16" SAE Washer, Flat	6

Field Setup

Use with a tractor having a minimum of 80 HP (60 KW). Tractor should have sufficient ground clearance for swath to pass cleanly under it.

PTO Speed

Unless otherwise specified, units are shipped with 1000 PTO speed. Units with 540 RPM PTO are also available, contact dealer.

The PTO should be run at approximately 1000 RPM. The front rubber rolls run at 645 RPM and the bottom steel roll runs at 1514 RPM at a tractor PTO speed of 1000. The upper steel roll runs at 1372 RPM at 1000 tractor PTO speed.

Pickup Height & Adjustment

The Macerator 6610 pickup should be adjusted so that it will cleanly pick up all material off of the field without gouging the soil. You may have to reset the height a few times to arrive at the best working height.

1. If your pickup is too low to the ground use your tractor hydraulic cylinder control to raise the pickup.
2. Remove pin (A) and slide adjuster bar (B) to desired height. Pushing bar in raises machine and pulling the bar out lowers the machine.
3. Reinsert pin and lock in place.

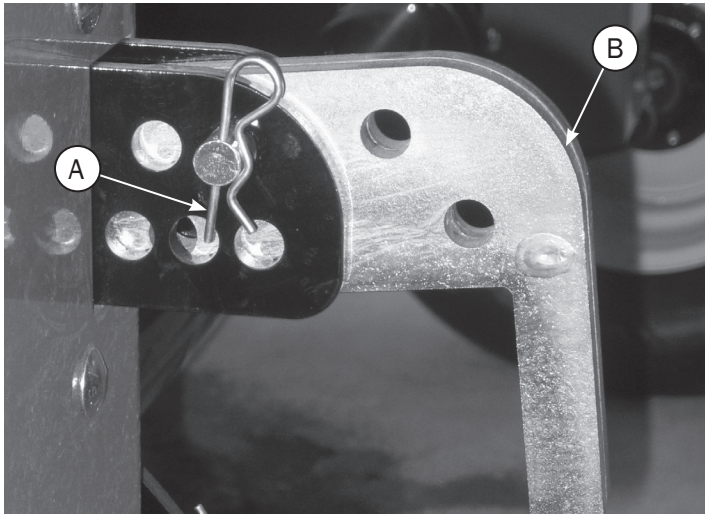

Steel Roll Adjustment

For best results adjust the Macerator 6610 for your specific field conditions. The smaller the gap between the steel serrated rolls the more aggressive will be the maceration of the hay. Both the space between the rolls and the air pressure need to be adjusted for maximum efficiency.

1. Raise the Macerator using the hydraulics.
2. Turn crank (A) clockwise to widen the gap or counter-clockwise to narrow the gap. 1/2 turn = .02" (0.5 mm). For a better fine tune, adjust bolt (D).
3. Be sure to set the gap exactly the same on both sides, use gauge.



4. Put crank lock (B) in place and secure with pin (C).
5. To assure that the rolls do not touch, the safety stop is set by the factory at 1/32" or .8 mm.
6. If safety stop (E) needs adjusting put travel pin (F) in place while unit is raised.
7. Adjust the safety stop bolt (E) as needed. Be sure the rolls don't touch during operation.
8. Repeat steps 1-7 to fine tune if necessary.

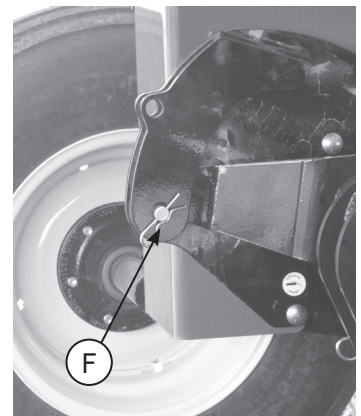
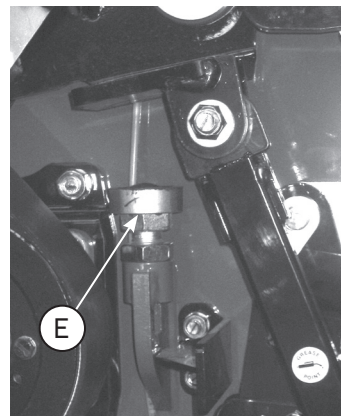
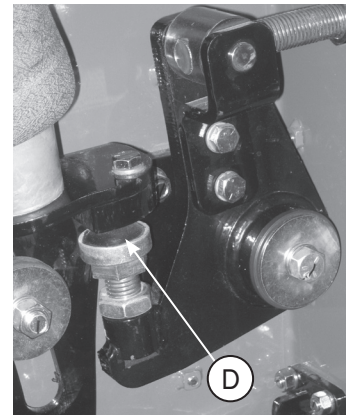
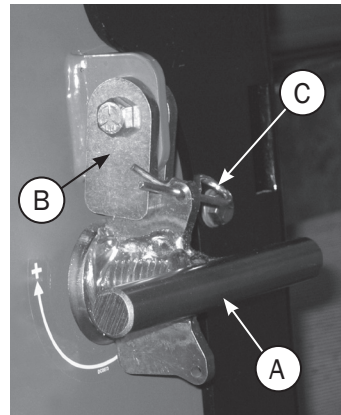

Preparation (Air System)

The purpose of the air system on the Macerator 6610 is to keep continuous pressure on the rolls.

The pressure can make a difference on how well the machine performs on the field. While the pressure on the rubber rolls may not be as crucial, too much pressure on the steel rolls will result in considerable leaf loss and some plugging may result in short wet hay.

Before heading out to the field, make sure the air pressure tank has a minimum of 100 PSI pressure. Not to exceed 120 PSI. This should give the operator sufficient air supply for the day.



3. If you experience too much leaf loss or the plants are crushed too intensely, lower the air pressure.
4. If there is not enough maceration, increase pressure to the rolls by increasing the air pressure. Make sure the gap is adjusted as per attached table.

Note: Steel Roll Pressure should not be set higher than 65 PSI at any time during field operation.

Rubber Roll Pressure Adjustment

The rubber rolls are designed to take the material from the pickup and feed it into the steel rolls. The rubber rolls do not crush or crimp the hay.

As a standard setting, we recommend 20–30 PSI pressure on the rubber rolls. Regulate the pressure by pulling out the knob on the regulator marked ‘rubber rolls’ and turning it clockwise or counter-clockwise. When turning the knob counter-clockwise you should hear the air escaping from the regulator.

In extreme conditions, increase or decrease the pressure. For example, very heavy swaths may require more pressure.



Figure 1

Steel Roll Pressure Adjustment

The steel serrated rolls (rear) take the material from the rubber rolls and crack the stems. To achieve the right setting, some field testing may be necessary. (Trial and error.)

1. Pull out the knob on the air regulator marked ‘steel rolls’ and turn the knob clockwise or counter-clockwise to set the pressure to the steel rolls as per attached table.
2. On 2008 Macerators, lower the Steel Roll Air Pressure by pulling the Relief Valve Ring at top of Left Side Air Bag (Fig. 1) to relieve pressurized air. (Make sure the Pressure Valve Knob is pulled out and turned all-the-way counter-clockwise before relieving air from bag.) Then repeat pressure setting as in step 1 above to set a new air pressure.



Initial Field Settings

Initial Recommended Roll Settings (Starting Point)

Crop Types	Steel Roll Gap	Steel Roll PSI	Rubber Roll Gap	Rubber Roll PSI
Timothy/Grasses	1/32" (0.8mm)	60	1/32" (0.8mm)	50
Bermuda/Brougham Grasses	1/32" (0.8mm)	60	1/32" (0.8mm)	50
Cereals, Oat Hay/Wheat	1/32" (0.8mm)	50	1/32" (0.8mm)	50
1st Cut Alfalfa	1/8" (3.1mm)	5	1/32" (0.8mm)	20
2nd, 3rd, 4th Cut Alfalfa	3/16" (4.8mm) - 1/4" (6.4mm)	5-7	1/32" (0.8mm)	15-20
Broad Leaf and Heavy Stemmed Plants	1/4" (6.4mm)	60	1/32" (0.8mm)	50

Checklist

CAUTION

Use Good Safety Practices When Working On This Machine

Before doing any maintenance or service on the machine you must:

- Park machine on a solid level surface.
- Lower the machine fully to the ground or onto blocks.
- Disengage all power.
- Put the tractor transmission in PARK or apply the tractor parking brake.
- Stop the tractor engine and remove key from the ignition.
- Look and listen. Make sure all moving parts have stopped.

First Time Use

- Tighten hub bolts A-E* after the first 1 hour of operation and repeat procedure after 10 hours and 50 hours.

***Important**

Hubs A - tighten to 60 ft. lbs.
Hubs B - tighten to 30 ft. lbs.
Hubs C - tighten to 9 ft. lbs.
Hubs D - tighten to 6 ft. lbs.
Hub E - tighten to 15 ft. lbs.

Daily

- Check and tighten all hub bolts.
- Remove all dirt and crop deposits from machine.

After The First 25 Hours Of Use

- Check bearing and set screw tightness.

At The Beginning Of Each Season

- Review all safety instructions.
- Carefully inspect all components for excessive wear or hazardous conditions.
- Lubricate the machine at all lubrication points.*
- Check tires for correct inflation pressure.
- Tighten bolts.

**See lubrication schedule and procedures on page 24.*

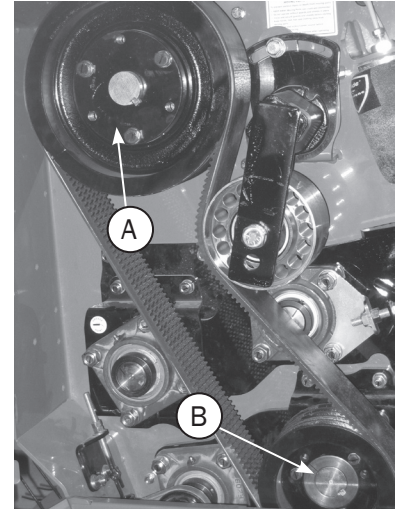
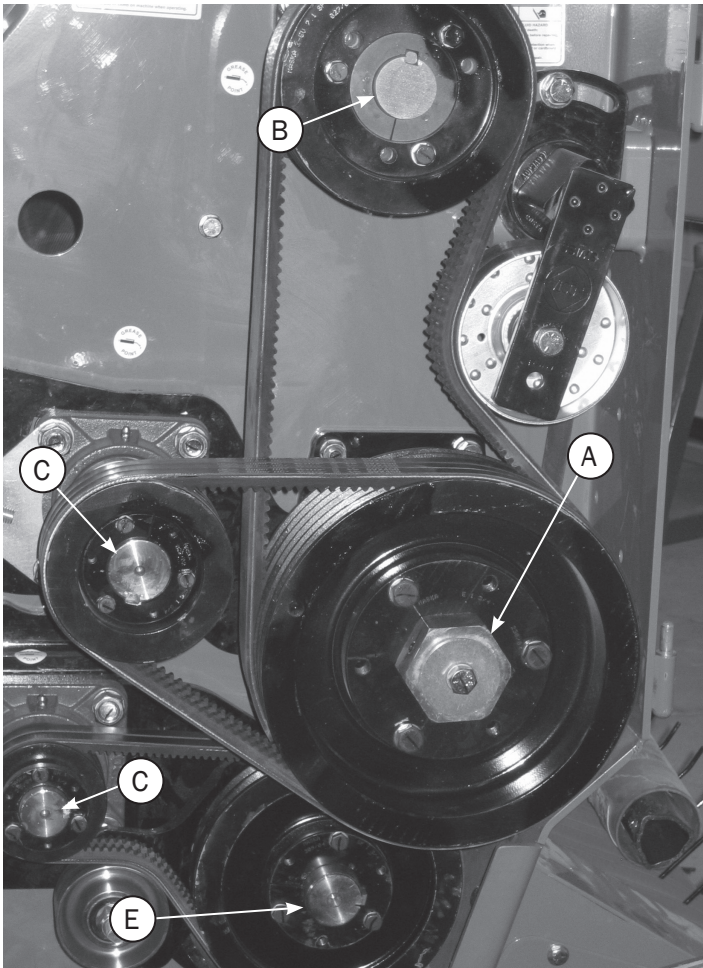

Roll Drive Belt Replacement

Replace worn or damaged belts as follows:

1. Raise Macerator and secure travel safety pin, see page 6.
2. To remove belts (A) loosen and turn flattened bolt (B) counter-clockwise.
3. To remove belts (C) loosen 4 bolts (D) then loosen bolt (E) and slide roll forward.*
4. To remove belt (F) loosen bolt (G) behind tightener, then loosen bolt (H) and slide tightener forward.
5. To remove belt (M) loosen bolt (N) on the other side of the panel behind tightener. Take tightening wrench (O) (use a pipe for leverage) and hold spring loaded tightener (P) firmly in place while loosening bolt (Q), then release tension slowly with wrench.
6. Replace all belts and tighten bolts (reverse sequence of steps 2-5).
7. To remove belt (J) loosen spring tension by turning off nut (K) counter-clockwise. To tighten the belt, tighten nuts (K) until you measure approximately 1-1/2 inches (L) or proper tension on the belt, see drawing below.
8. Reinstall all covers.

* To maintain proper roll alignment be sure to adjust the opposite tightener on the other side of the machine.

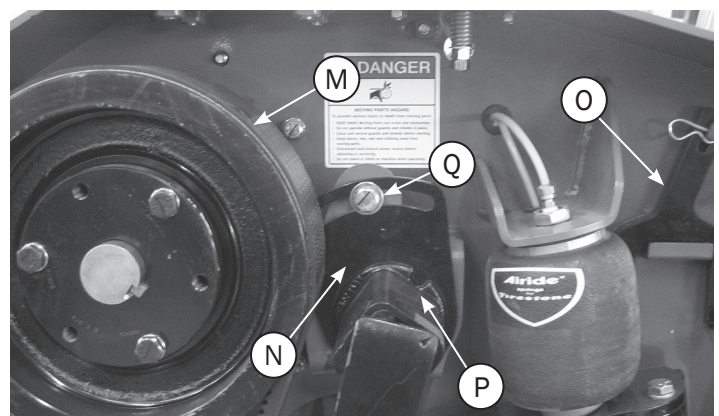
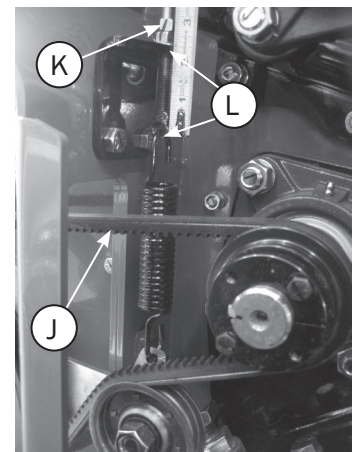
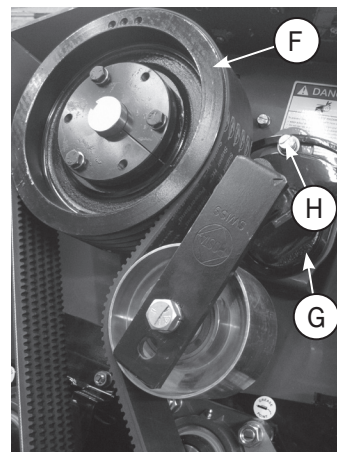
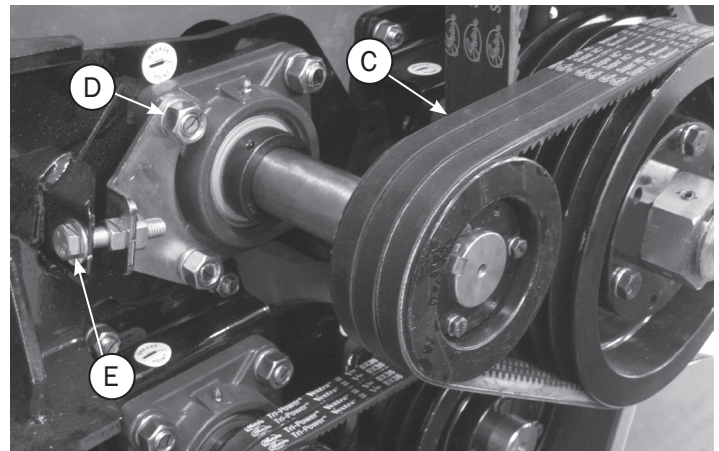
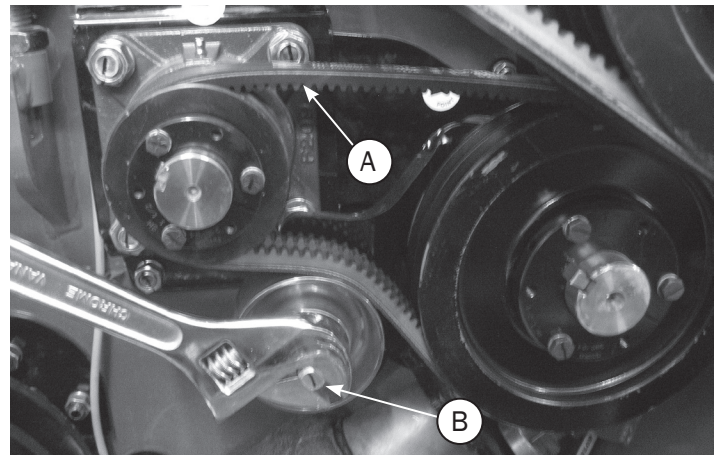
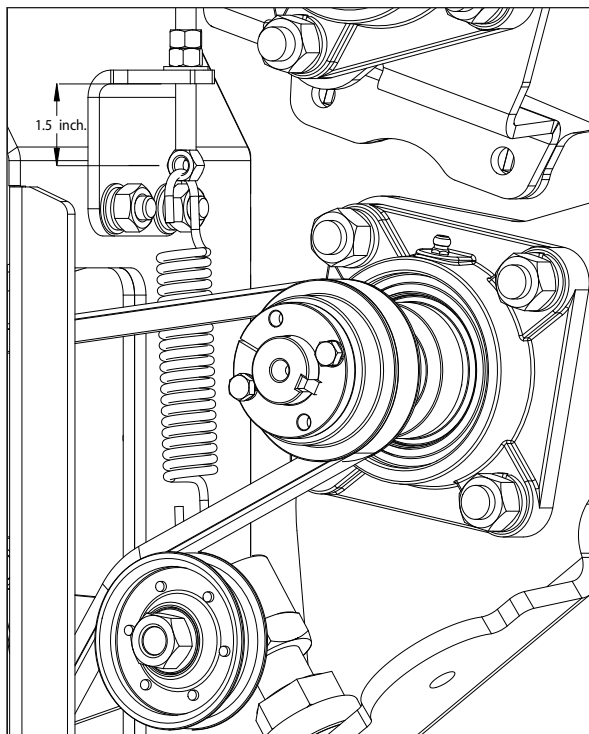

Maintenance

Bearing Replacement

Sealed ball bearings are held in position on the shaft by a locking collar, Figure 1, which is rotated to lock the assembly on the shaft and secured by a set screw. To remove bearing:

1. Loosen set screw.
2. Use a drift punch inserted in the drift pin hole to rotate and loosen the locking collar (A). Rotate the locking collar counter-shaft rotation.
3. Remove the locking collar.
4. Support the shaft, for easier assembly later.
5. Remove the bolts for the bearing flanges.
6. Slide the bearing and the flanges from the shaft. Note: Cleaning paint and corrosion from the shaft will make removal easier.
7. Put on the new bearing and flanges.
8. Replace locking collar on the shaft. Rotate the locking collar in the direction of the shaft rotation until lightly engaged. Tighten the collar by hitting it with a drift pin punch inserted in the drift pin hole rotating it further until fully tightened.
9. Tighten set screw.

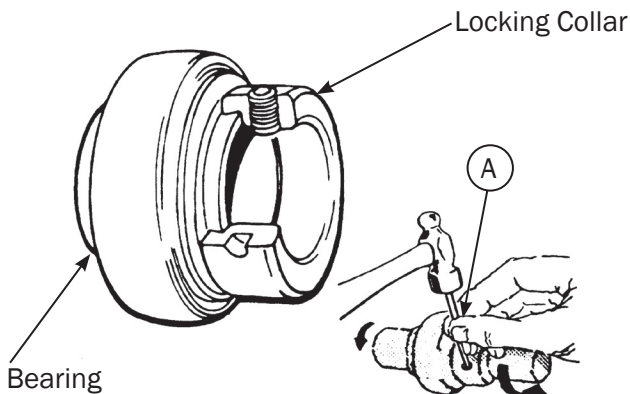

Figure 1

Replacing or Repacking Wheel Bearings

1. Remove wheel hubs and disassemble.
2. Clean bearings, seals, caps, washers, nuts, and hubs with kerosene or other solvent.
3. Replace bearings or seals if worn or damaged.
4. Pack bearing cones and seals with No. 2 multipurpose lithium grease or equivalent.
5. Reassemble hub and bearings, Figure 2.
6. Press cups against the shoulder in the hub.

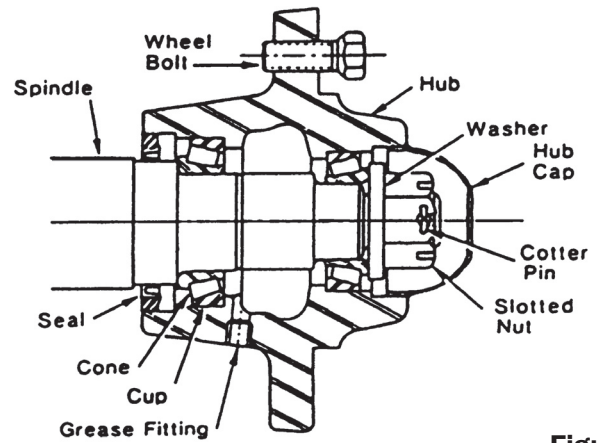

Figure 2

1. Press seal flush into hub after bearing.
2. Place hub on shaft taking care not to damage the seal.
3. Tighten the wheel bearing nut. Do not overtighten.
4. Secure nut with a cotter pin.
5. Be sure to replace hub cap.

Pickup Teeth, Wrappers, and Wear Strips

Check for bent, broken or loose parts. If it is necessary to replace teeth or related parts, proceed as follows.

1. Ensure that your Macerator is blocked securely. Loosen the bolt holding the wrapper(s) on pickup, Figure 3. Lift the wrapper on top, tilt and slide forward to remove, Figure 4.
2. Should the plastic wear strip require removal and replacement, drill out or carefully grind off the 'pop' rivets. Replace strip with new rivets, Figure 5.
3. Install new teeth or wrapper(s).

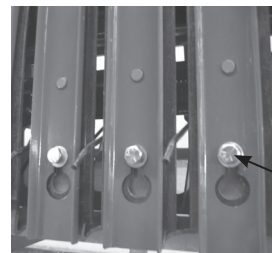

Figure 3



Figure 4

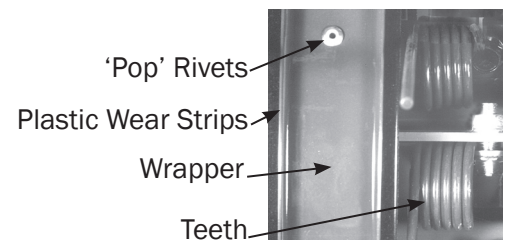

Figure 5

Inch Torque Chart for Bolts and Nuts

Standard Torque Requirements Foot-Pounds
Use this chart as a guide when tightening bolts/nuts which do not have special torque requirements.

Bolt Diameter	Bolts		Locknuts	
	SAE Grade 5 Plated W/ZnCr	SAE Grade 8 Plated W/ZnCr	Grade B with GR5 Bolt	Grade C with GR8 Bolt
1/4	112*	157*	61*	86*
5/16	229*	324*	125*	176*
3/8	34	48	19	26
7/16	54	77	30	42
1/2	83	117	45	64
9/16	120	169	65	92
5/8	165	233	90	127
3/4	293	413	160	226
7/8	473	667	258	364
1	708	1000	386	545



SAE Grade 5

SAE Grade 8

*Torque values are inch-pounds.

Note: For inch and metric bolts and nuts:

- These values are based on clean, dry threads. Reduce the value by 10% when a lubricant is used. Reduce the value by 20% if new plated bolts are used.
- Bolts threaded into aluminum must have two diameters of thread engagement and may require 30% more reduction in the torque.

Metric Torque Chart for Bolts and Nuts

Standard Torque Requirements Foot-Pounds
Use this chart as a guide when tightening bolts/nuts which do not have special torque requirements.

Metric Bolt Markings & Torque Values

Metric bolts are identified by the grade number stamped on the head of the bolt or on the surface of metric nuts. The higher the number, the greater the strength of the bolt.

Bolt Diameter	Grade 8.8	Grade 10.9
6mm	60*	108*
7mm	108*	168*
8mm	18	23
10mm	30	45
12mm	55	75
14mm	85	120
16mm	130	175
18mm	170	240



*Torque values are inch-pounds.

Lubrication

General Information

A NLGI No. 2 multi-purpose high temperature lithium base grease is recommended.

Use a manual grease gun for all greasing. Air powered grease guns may damage the seal on the bearings.

Wipe all grease fittings with a clean cloth before greasing to avoid injecting dirt or grit in the bearings.

At The Beginning Of The Season

Grease all the sealed bearings, front rolls (two places), rear rolls (two places) and drive shaft (one place) every 50 hours, I-shot, Figures 1 and 2.

And thereafter grease all sealed bearings and universal joints weekly or every 50 hrs. Bushings and axle bushings daily or every 10 hrs.

It is recommended that the steel roll bearings be changed every 3000 acres or yearly.

It is also recommended that the pickup cam follower bearings be changed on a yearly basis.

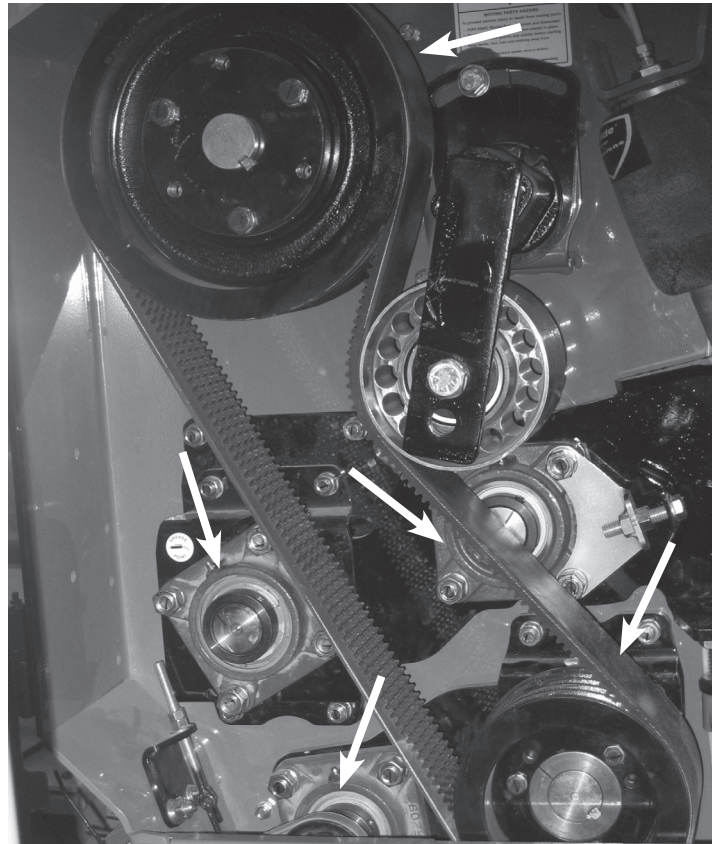

Figure 1

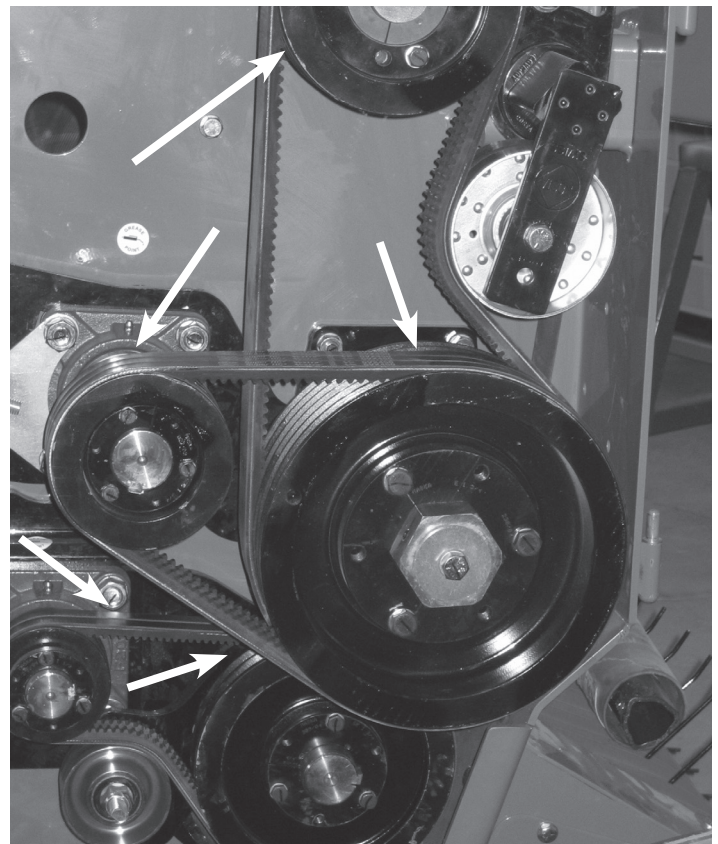
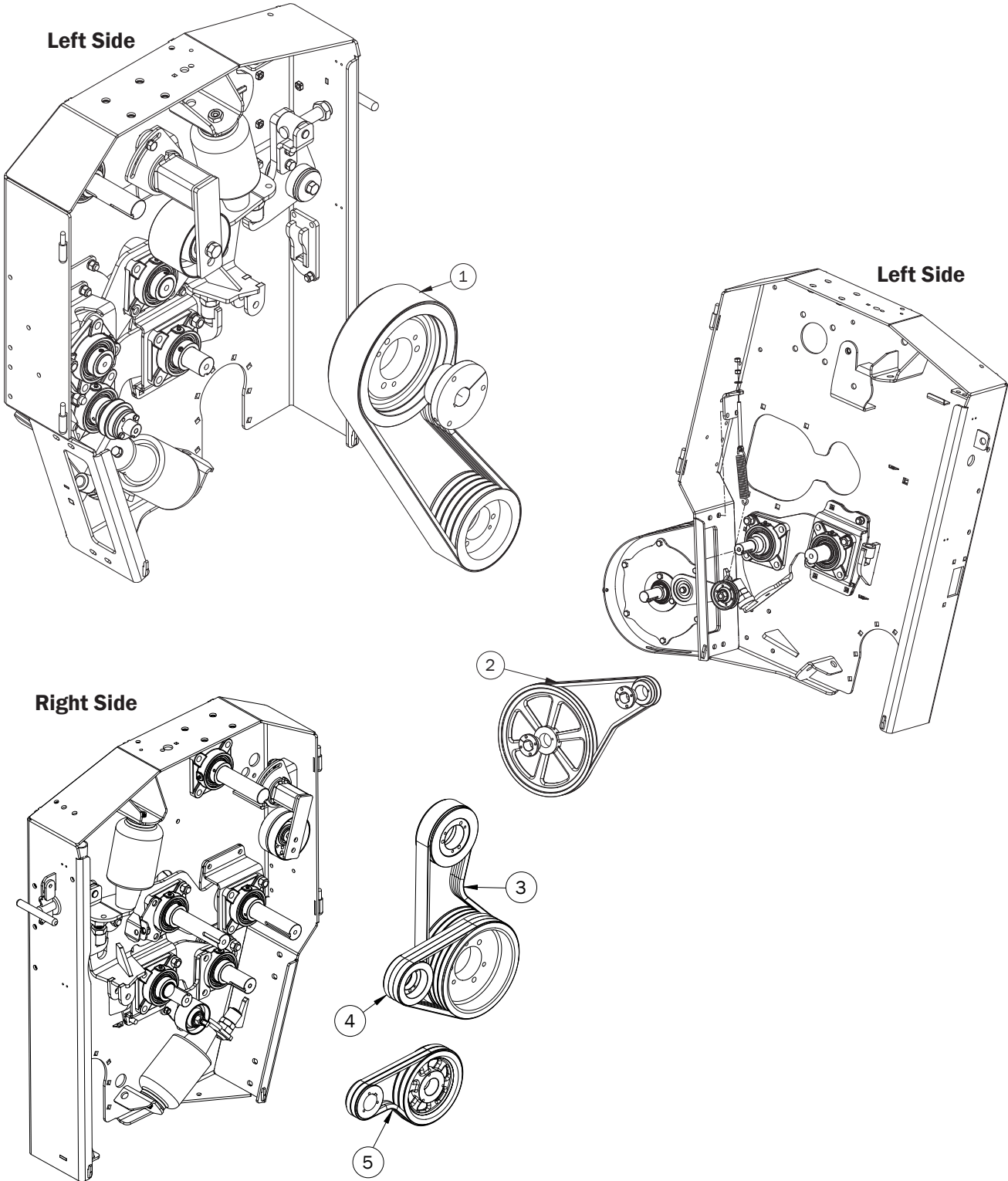

Figure 2

Reference	Part Number	Description	Drive	Qty.
1	806943	5-5VX800	Bottom Steel Roll	1
2	802922	BX-54	Pickup	1
3	806942	3-5VX630	Top Rubber Roll	1
4	802911	5VX450	Top Steel Roll	3
5	802917	BX-36	Bottom Rubber Roll	2



Optional Kits

The following is a list of the Optional Kits for the Macerator, please contact your Dealer for availability and pricing.

Kit Number	Description
K107	Gathering Wheels Kit
K6005	Tooth Clamp Kit
K6008	Alfalfa Roll Speed Kit
K6009	Air Regulator Kit
K6010	Hitch Clevis Kit
K6012	Windrower Reinforcement Kit
K6016	Bottom Rubber Roll Adjustment Bracket Revision, L/H and R/H

Problem	Possible Cause	Solution
Pickup is skipping swath or not picking cleanly.	<ul style="list-style-type: none"> ▪ Missing or broken pickup teeth. ▪ Pickup too high. ▪ Driving too fast for pickup speed. ▪ Not following the same direction as swath was cut. 	<ul style="list-style-type: none"> ▪ Replace missing teeth. ▪ Adjust pickup height. ▪ Use lower tractor gear with higher RPM. ▪ Follow same direction as swath cut.
Material wrapping in pickup.	<ul style="list-style-type: none"> ▪ Pickup running too low. ▪ Pickup and travel speeds are not matched. 	<ul style="list-style-type: none"> ▪ Set pickup teeth 1" to 2" above ground. ▪ Match pickup and ground speed as close as possible.
Breakage or bending of pickup teeth.	<ul style="list-style-type: none"> ▪ Running pickup too low. ▪ Excessive pickup rotation speed in rough or rocky conditions. 	<ul style="list-style-type: none"> ▪ Adjust pickup height. ▪ Reduce pickup or ground speed.
Excessive noise or heat from gear box.	<ul style="list-style-type: none"> ▪ Insufficient oil in gear box. ▪ Worn or broken parts inside gear box. 	<ul style="list-style-type: none"> ▪ Top up gear oil as needed. ▪ Replace parts as needed.
Air pressure does not hold in air tank and air bags.	<ul style="list-style-type: none"> ▪ Broken air line. ▪ Torn or punctured air bag. ▪ Air regulator not working. 	<ul style="list-style-type: none"> ▪ Repair or replace line as needed. ▪ Replace air bag as needed. ▪ Clean or replace regulator.
Pickup does not rise or lower.	<ul style="list-style-type: none"> ▪ Worn or punctured hydraulic cylinder or hydraulic oil line. ▪ Bushings too tight. 	<ul style="list-style-type: none"> ▪ Replace hydraulic lines and cylinders as needed. ▪ Replace or clean bushings.
Pickup height adjustment does not hold.	<ul style="list-style-type: none"> ▪ Broken or worn parts on adjuster. 	<ul style="list-style-type: none"> ▪ Replace worn parts as needed.
Rubber rolls not feeding properly.	<ul style="list-style-type: none"> ▪ Air pressure too high or low. ▪ Gap between rolls too tight or too wide. 	<ul style="list-style-type: none"> ▪ Adjust air pressure using regulator. ▪ Adjust gap width.
Wax build up on steel rolls.	<ul style="list-style-type: none"> ▪ Temperature and hay conditions cause the wax to come off of the plant and stick to the rolls. 	<ul style="list-style-type: none"> ▪ The wax will come off after the rolls cool down. A thin layer of wax/leaves will build up on the rolls.
Excessive leaf loss.	<ul style="list-style-type: none"> ▪ Too much air pressure on steel rolls. ▪ Hay conditions too dry. ▪ The gap between steel rolls is too narrow or the rolls are going too fast. 	<ul style="list-style-type: none"> ▪ Release air pressure. ▪ Condition hay early in the morning. ▪ Adjust gap between steel rolls.
Hay is not being macerated.	<ul style="list-style-type: none"> ▪ Not enough air pressure on steel rolls. ▪ Gap between rolls is too wide. ▪ Windrow is too thick. ▪ Steel rolls not running fast enough. 	<ul style="list-style-type: none"> ▪ Adjust air pressure as required. ▪ Narrow the gap between steel rolls. ▪ Cut wider or thinner windrows. ▪ Increase tractor RPM.
Swath not being inverted completely.	<ul style="list-style-type: none"> ▪ Mold board is not adjusted properly. 	<ul style="list-style-type: none"> ▪ Adjust mold board angle. The tighter angle will result in less inversion. The wider angle will result in a greater inversion.

LIMITED WARRANTY

Warranty service will be performed by AgLand Dealer authorized to sell the Macerator.

AGLAND WARRANTY

AgLand Industries Inc. manufactures the AgLand Macerator. AgLand Industries Inc. (Manufacturer) warrants each Macerator sold by it to be free of defects in material or workmanship under normal use and service. The sole obligation of the Manufacturer is limited to repairing or replacing, as the Manufacturer may elect, any part or parts that prove, in the Manufacturer's judgement, to be defective in material or workmanship within one year* after delivery to the original Retail Purchaser under normal farm use. The defective part or parts will be replaced or repaired only to the original Retail Purchaser. Warranty repair or replacement will be done at the location of the AgLand dealer who sold the Macerator. Defective parts must be returned to the Manufacturer or Dealer who sold the Macerator at the expense of the Retail Purchaser to be inspected by the Manufacturer. Purchaser must give written notice to the Dealer from whom the Macerator was purchased of any claimed defect and the Dealer will repair or replace the part or parts found to be defective.

***3 months after delivery when purchased by a commercial operator.**

Note: The sole remedy of the Purchaser for claim under this warranty is the repair or replacement of defective parts.

This warranty does not extend to the drive components or tires, which are made by other manufacturers and carry warranties from said manufacturers. There are no representations, warranties, or conditions, express or implied, statutory or otherwise, except those herein contained and no agreement collateral otherwise except those herein contained, and no agreement collateral hereto shall be binding upon either party unless in writing hereon or attached hereto, signed by the Purchaser and accepted by the Manufacturer at its head office.

SERVICE AND WARRANTY INFORMATION

The Manufacturer's liability under this warranty is limited to the repairing or replacing of parts only, and the Manufacturer shall in no event be liable to the Retail Purchaser for consequential damage or loss of profits sustained by it as a result of any defect in material or workmanship on any of the equipment covered by this warranty.

The Macerator is warranted for agricultural use only. This warranty does not cover claims resulting from any use for other than agricultural applications.

Altering, modifying or adding additional equipment which is not approved for installation on the Macerator by the Manufacturer will void this warranty.

All warranties are subject to legislation of the state or province in which the Macerator is sold.

Note: There are no warranties, express or implied, by the Manufacturer or its Dealer regarding the Macerator except the warranty against defects in the material or workmanship expressed herein. No person is authorized to bind the Manufacturer to any other warranty whatsoever.

The Manufacturer reserves the right at any time to make changes in the design, material, parts, or specifications of the Macerator without thereby becoming liable to make similar changes in equipment, machinery or parts previously manufactured.



AgLand Industries Inc.