



OPERATOR'S / PARTS MANUAL



SilaTube Model P-6500

No. C1852

Up to serial # 2087

04/02

VISIT OUR WEBSITE



www.pronovost.qc.ca

Copyright © Les Machineries Pronovost Inc., 2002

All rights reserved.
Printed in Canada.

TABLE OF CONTENTS

Section	Item	Page
1	Introduction	5
2	Safety	6
	General Safety	6
	Safety in Operation	6
	Safety with Maintenance	7
	Safety in Transport	7
	Safety in Storage	7
3	Decals	8
	Safety Decals	8
	Maintenance Decals	10
4	Operation	11
	Basic Start-up Procedures	11
	Adjustment of Silatube	14
	Position of the mobile top part of the arch	16
	Ground preparation	20
	Operation of Silatube	21
5	Maintenance	25
6	Storage	26
7	Specifications	27
8	Parts List	28
	SilaTube P-6500	28
	Motorized moving kit	32
	Detail of Arch Model P-6500	33
	Cylinder 25TR04 & 25TR08	34
	Cylinder 40TR04	35
	Arch Cylinder 40Z30	36
	Pusher Cylinder 30I60	37
	Cylinder 30HL17	38
	Valve SD5	39
	Double hydraulic pump MHP-22067/048K2RS	40
	Engine Assembly with Pump	41
	Hub H2500	42
	Hydraulic System	43
	Electric System	46
	Electric Circuit	48
	Hydraulic motor for motorized moving kit DH315	49
9	Torque Chart	50
10	Warranty	51

INTRODUCTION

CONGRATULATIONS!

Thank you for choosing PRONOVOST. We are confident this equipment will meet your requirements in terms of quality, performance and reliability.

This manual was prepared to assist you in the safe operation of your new SilaTube. It contains important information which will help you achieve excellent returns with your tubing-machine for years to come.

Please read this manual completely before operating your SilaTube and keep it for future reference.

Before starting the machine, you or any other person who will be operating the SilaTube must familiarize yourself with the safety recommendations and the operating instructions. Please read carefully and be sure to understand and follow all recommendations and procedures.

In this manual, the right and left sides of the SilaTube are identified while standing at the discharge end of the machine and facing it.

If you require additional information on your SilaTube, please contact your PRONOVOST Dealer.

NOW take a moment to enter the model, serial number and the date of purchase of your SilaTube in the space provided.

When ordering parts from your Dealer, please refer to these numbers for a fast and efficient service. Use PRONOVOST parts for replacement.

The model and serial numbers are on the nameplate shown on Fig. 1.



Figure 1

MODEL: _____ ✍

SERIAL NO.: _____ ✍

DATE OF PURCHASE: _____ ✍

SAFETY

GENERAL SAFETY

2

WHEN YOU SEE THIS SYMBOL



ATTENTION!

**BE ALERT
YOUR SAFETY IS INVOLVED**

This symbol «**SAFETY ALERT**» is used in this manual and on the safety decals on the SilaTube. It warns you of the possibility of danger. Carefully read, understand and follow all safety recommendations before operating the SilaTube.

- 1) Careful operation is the best assurance against accidents. Carefully read this manual and the motor manual and follow all recommendations before operating your SilaTube. It is the owner's responsibility to make sure that anyone who will operate the SilaTube will read these manuals before operating the equipment.
- 2) Never let a child operate the SilaTube.
- 3) Do not modify the SilaTube. Any non authorized modification may affect the efficiency and/or safety of the equipment.
- 4) Never operate the SilaTube with defective parts or if damaged in any way. Have it repaired before operating.
- 5) Make sure all fasteners are in place and properly secured or tightened. Refer to torque chart on page 50.
- 6) Avoid wearing loose fitting clothing when working with the SilaTube. These could get entangled in moving parts of the equipment and

cause accidents.

- 7) Keep motor clean and exempt of dust and debris.
- 8) Before using the SilaTube, inspect the area where it is to be used and remove any object which could hamper normal operation or damage the plastic tube.
- 9) Hydraulic fluids under pressure can damage your skin. Do not use your hands to locate a leak.
- 10) Plastic bags are impervious to air. Keep them away from children to avoid suffocation.
- 11) When using a tractor equipped with a spear, be extremely careful. Always lower the spear to the ground before leaving your tractor.
- 12) Do not store, spill or use fuel near a flame, a hot engine or stove.

SAFETY IN OPERATION

- 1) Be sure there are no obstructions around the equipment and that no one stands near the SilaTube when in operation.
- 2) Always refuel equipment when outside and away from flames or sparks.
- 3) Never run the engine inside. Do not operate the engine in a confined or non ventilated area. Carbon monoxide is a colorless, odorless and deadly gas.
- 4) Be careful when adjusting equipment with engine running.
- 5) Keep hands, feet, hair and clothing away from moving parts.
- 6) Should you need to step onto the SilaTube for whatever reasons, **ALWAYS** stop the motor since there is **RISK OF SERIOUS INJURY** if not stopped.

SAFETY (cont'd)

- 7) Do not refill fuel tank with engine running. Always let the engine cool off for a couple of minutes before refilling. Always use approved fuel containers.
- 8) Do not operate the engine if fuel is spilled. Move equipment away from the spill and avoid any spark until the complete evaporation of the fuel.
- 9) Do not smoke while refueling.
- 10) Do not operate engine with any accumulation of hay, leaves, dirt or any other combustible material near the exhaust muffler.
- 11) Avoid touching the hot muffler and cooling fins since they could cause burns to your skin.

SAFETY WITH MAINTENANCE

- 1) Perform the SilaTube maintenance according to the recommendations contained in this manual.
- 2) Stop engine and relieve all hydraulic pressures before doing inspection, maintenance or repairs.
- 3) Do not check spark with spark plug or wire removed. Use the appropriate testing equipment.
- 4) Regularly check fuel lines and fittings for leaks. Replace if necessary.

SAFETY IN TRANSPORT

- 1) Place wheels and pole in transport (towing) position to obtain a width of 118" (Fig. 2).
- 2) Check local regulations for the transport of your SilaTube on the road.
- 3) Be alert when pulling the SilaTube on the road. Do not allow anyone to stand on it while in motion.
- 4) Never exceed the speed that permits full steering and braking control at all times.

- 5) Be careful while backing up.

SAFETY IN STORAGE

- 1) Let engine cool and drain fuel from tank.
- 2) Do not let children play in the area where the SilaTube is stored.
- 3) Do not leave a Tube installed on the SilaTube.
- 4) Do not let the SilaTube stand on the tires. Lower it to the ground or on wooden blocks. **THIS WILL AVOID ANY ACCIDENTAL CRUSHING OF ANIMALS OR ANYONE WHO COULD CRAWL UNDER THE EQUIPMENT.**

2



Figure 2

DECALS

SAFETY DECALS

The safety decals are affixed wherever special safety precautions are indicated. Locate them on the machine and read them carefully. If a decal is damaged, lost or illegible, install a new one. Each decal is identified with a letter and part number. The following photos indicate where each one must be installed.

3

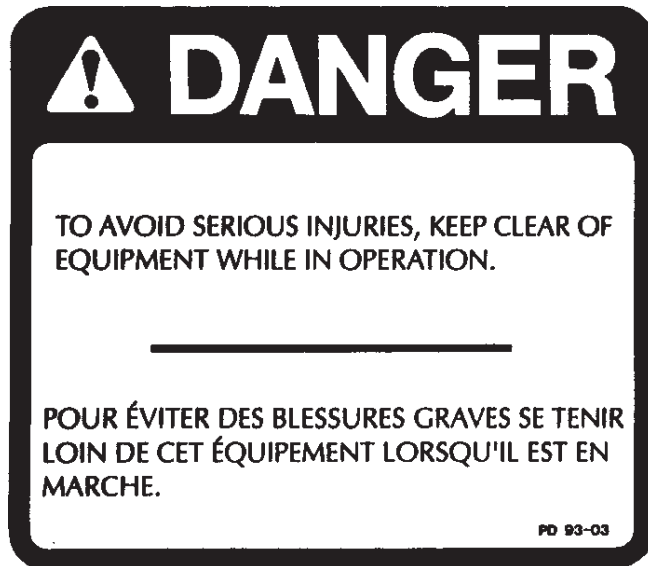

Figure 3
Decal A

Part no.: A101

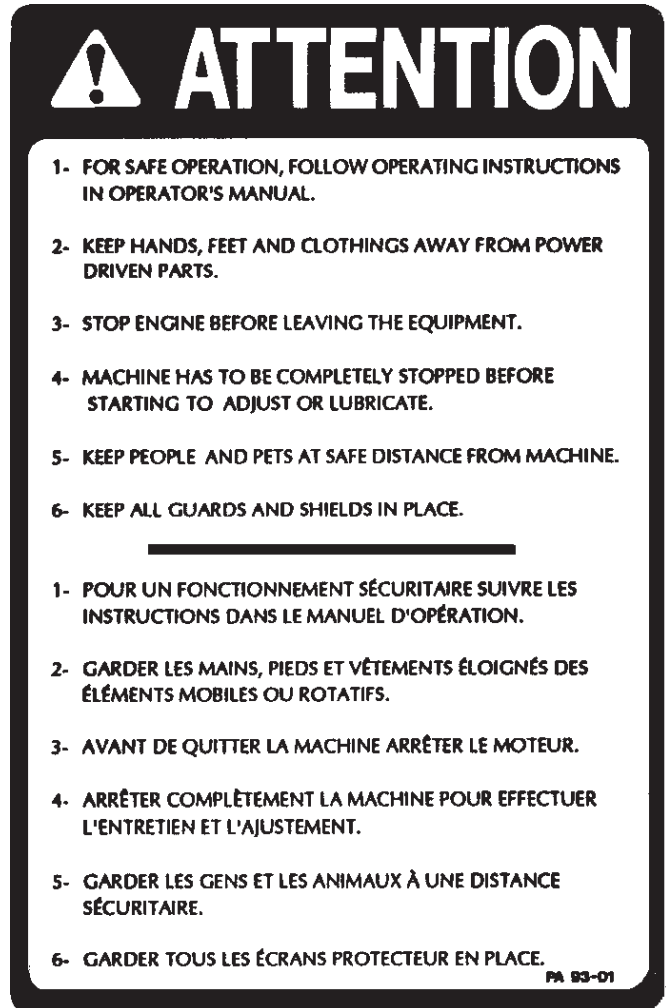

Figure 5
Decal B

Part no.: A102

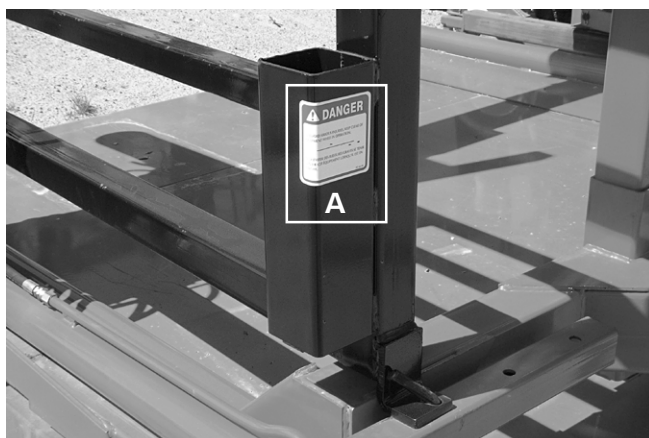

Figure 4



Figure 6

DECALS (cont'd)



Figure 7
Decal C

Part no.: A103



Figure 8

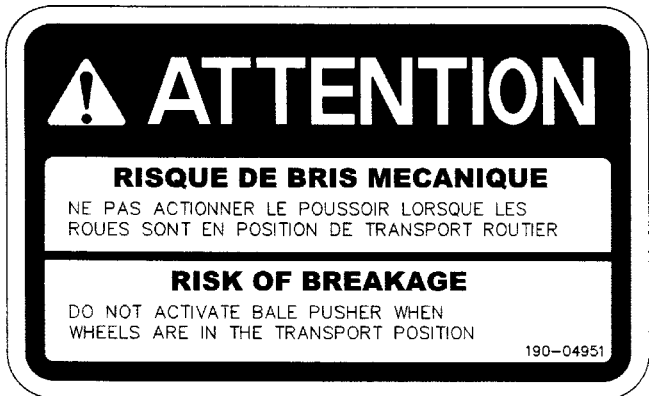

Figure 9
Decal D

Part no.: 190-04951



Figure 10

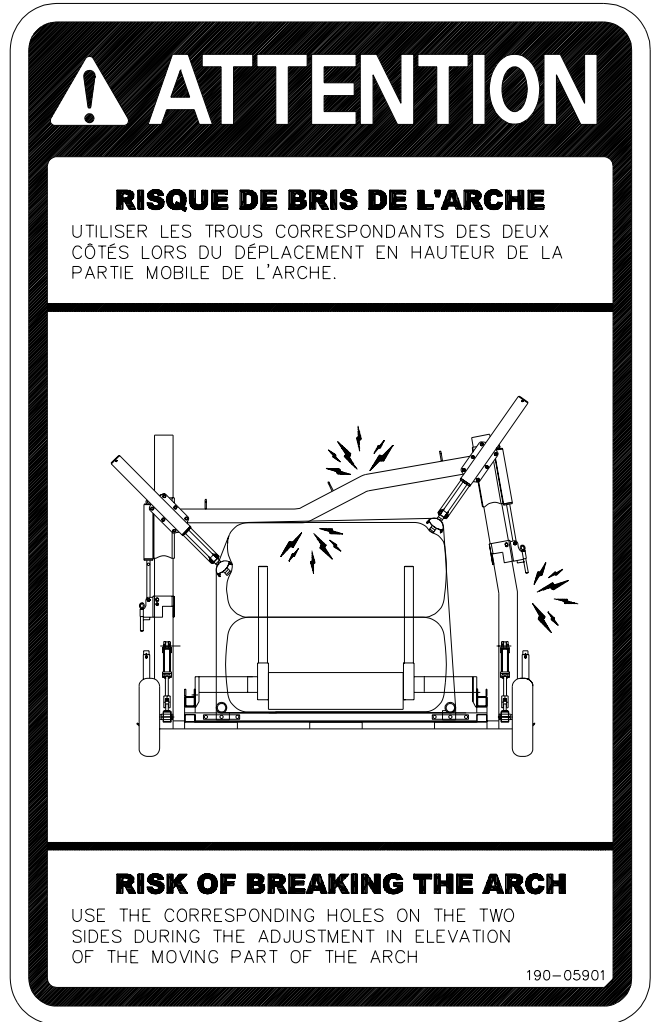

Figure 11
Decal E

Part no.: 190-05901



Figure 12

3

DECALS (cont'd)

MAINTENANCE DECALS

The maintenance decals indicate the points requiring lubrication. Refer to the maintenance section for more details.

3



Figure 13
Decal F

Part no.: A104



Figure 14



Figure 15

Part no.: A 106

OPERATION



Figure 16

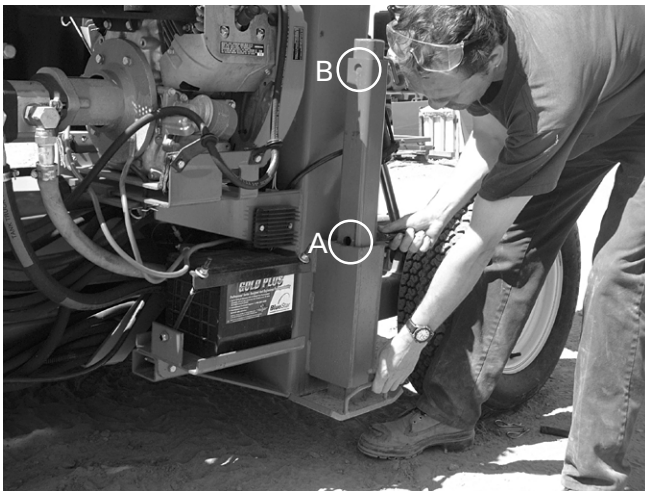

Figure 17



Figure 18

BASIC START-UP PROCEDURES

- 1) Verify for adequate tightness of all fastening devices. Refer to torque chart on page 50.
- 2) Lubricate all points and guide mechanisms requiring grease, with a high quality lithium base grease containing molybdenum disulfide (MoS₂) such as «Esso Unirex EP1 Moly», «DARINA XL-Multi Season Moly, Grade #1» from Shell or equivalent.
- 3) Check oil level in hydraulic reservoir. Use good quality tractor transmission and hydraulic system oil such as «Trans Hydraulic Duratran» from Petro Canada, «DONAX TD» from Shell or equivalent.
- 4) Check tire pressure and adjust according to recommendation indicated on the tires.
- 5) Check engine oil level.
- 6) A raising stand is set to each side of the SilaTube to ease coupling to towing vehicle (figure 2 p.7) and change of wheel position. Use the left hand stand to couple to towing vehicle and, use both simultaneously to change wheel position.
- 7) Proceed as follows to use the stands. Lock mobile top part of the arch where indicated (figure 16) with locking pin. The lower part of the cylinder being free, this part will push on the stand to raise the SilaTube.
- 8) Free the stand by removing locking pin from position A (A figure 17). Lower telescopic part and insert locking pin at position B (figure 18).

4

OPERATION (cont'd)

4



Figure 19



Figure 20



Figure 21

- 9) Now slowly stretch cylinder to raise the SilaTube to desired height (figure 19).
- 10) Place wheels in working position before proceeding with the start up procedure (figure 20).
- 11) Check the operation of all hydraulic cylinders.
- 12) Check the operation of the bale pusher mechanism. It must operate freely and return to its starting position automatically.
- 13) Your SilaTube has hydraulic manual controls (1 Fig. 21), electrohydraulic controls for some functions (2 Fig. 21), and a remote control (Fig. 22) from which you can control the main functions. The **grey** button **makes the pusher move forward**. The **red** button **stops the pusher and returns it to its starting position**. The **yellow** button makes the SilaTube **turn to the left side** and the **green** button to the **right side**.



Figure 22

OPERATION (cont'd)

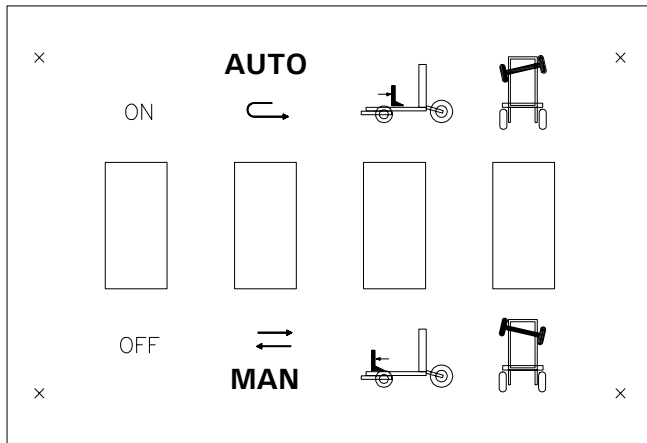

Figure 23

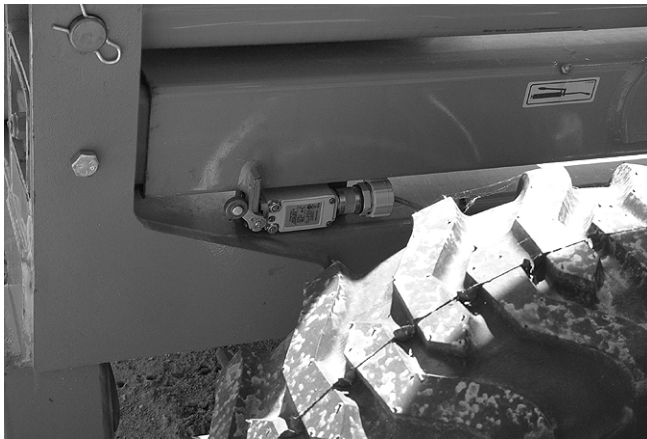
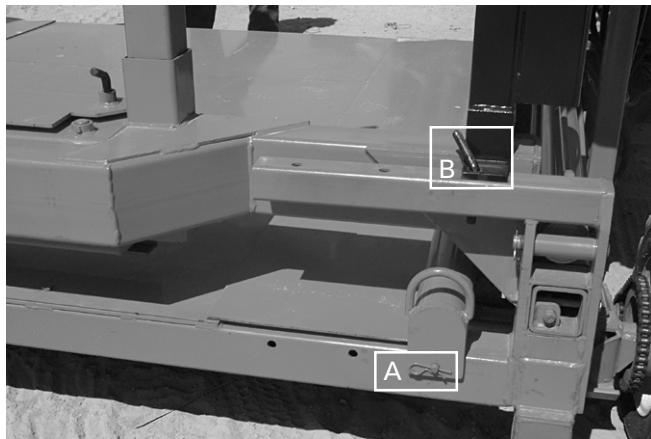

Figure 24

- 14) The control box on the SilaTube (Fig. 23) controls the following functions. From left to right, the **first button turns on the hydraulic system**. The **second button selects the pusher operation mode manual or automatic** (when the pusher moves forward and returns to its starting position automatically). The **third button moves the pusher forward or backward**. The **fourth button turns the SilaTube to the left or to the right**.
- 15) There are two limit switches (Fig. 24), they are used to adjust the length of travel of the pusher in automatic mode.
- 16) Check the surface of the stretcher arms for smoothness. Any mark or protrusion could cause the tube to tear.

4

OPERATION (cont'd)



4 Figure 25

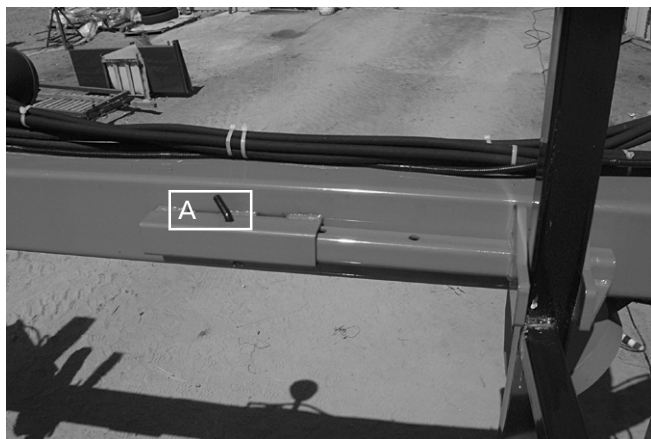

Figure 26

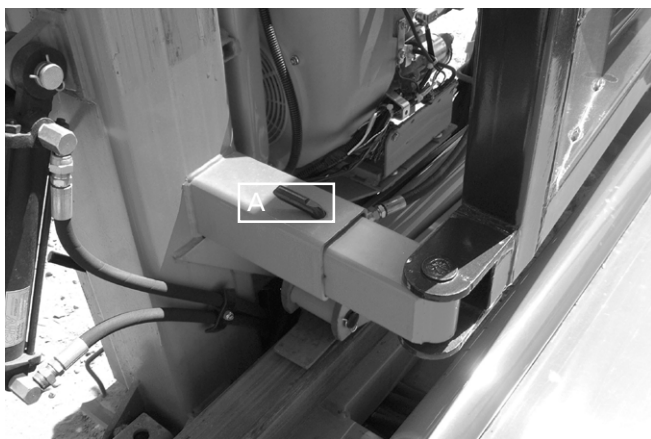

Figure 27

ADJUSTMENT OF SILATUBE

Note.: When making adjustments to the SilaTube, it is very important to work both sides simultaneously and in a symmetrical fashion. Use corresponding holes on both sides.

- 1) Your SilaTube is designed to bag square bales. The SilaTube can be adjusted for bales of 72", 84" or 96" long which will be transversely set on the machine. One or more bales can be set on top of another without exceeding 72" high.
- 2) Adjust the bale guide to desired dimension. Remove locking pin (A figure 25), raise front part of the bale guide and slide it back a few inches to remove it from its rear hook. Then place the guide in the desired position and pull to the front to re hook it in its new position. Lower the front part and put back the locking pin. Adjust the other side symmetrically by repeating the preceding steps.
- 3) Adjust the lateral guides to required dimension. Remove the two pins at rear of guide, on top (A figure 26) at bottom (A figure 27). Adjust rear part of guide to desired position and install the two pins. To adjust the front end, remove pin (B figure 25), slide the guide to desired position and install pin. Adjust the other side symmetrically by repeating the preceding steps.

OPERATION (cont'd)



Figure 28

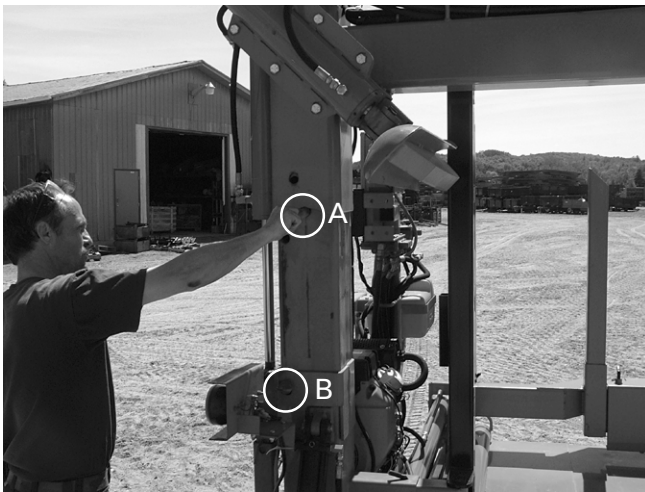

Figure 29



Figure 30

- 4) The height adjustment of the mobile arch is done step by step, one level at a time. Proceed as follows:
ADJUST SIMULTANEOUSLY AND SYMMÉTRICALLY BOTH SIDES

- 5) **RAISING THE ARCH:**

- A) Insert a pin in the setting ring at the base of the cylinder (figure 28).
- B) Open the cylinders at the maximum and place a pin at the bottom of the mobile arch (A figure 29) to keep it from lowering.
- C) Remove pressure on the pin at the setting ring situated at the base of the cylinder (B figure 29) and remove the pin.
- D) Close the cylinder completely and put the pin back in the setting ring at the base of the cylinder as shown in (A figure 30).
To raise to the next level, repeat steps B, C and D.

- 6) **LOWERING THE ARCH:**

- A) Insert a pin at the bottom of the mobile arch (B figure 30) remove the pin from the setting ring situated at the bottom of the cylinder (A figure 30).
- B) Extend the cylinder at the maximum and insert a pin in the setting ring situated at the bottom of the cylinder (B figure 29).
- C) Remove pressure from the pin at the bottom of the mobile arch (A figure 29) by slightly extending the cylinder and remove the pin.
- D) Close the cylinder to the minimum and insert pin where shown (B figure 30).
To lower to the next level, repeat steps B, C and D.

- 7) When tubing the bales, only the pin in the setting ring situated at the bottom of the cylinder is used. The height of the mobile arch is controlled by the cylinders.

- 8) The following drawings (page 16 to 20) show how to set the mobile arch as per bales to be tubed. Adjust to the required position.

OPERATION (cont'd)

HEIGHT ADJUSTMENT OF THE MOBILE ARCH

4

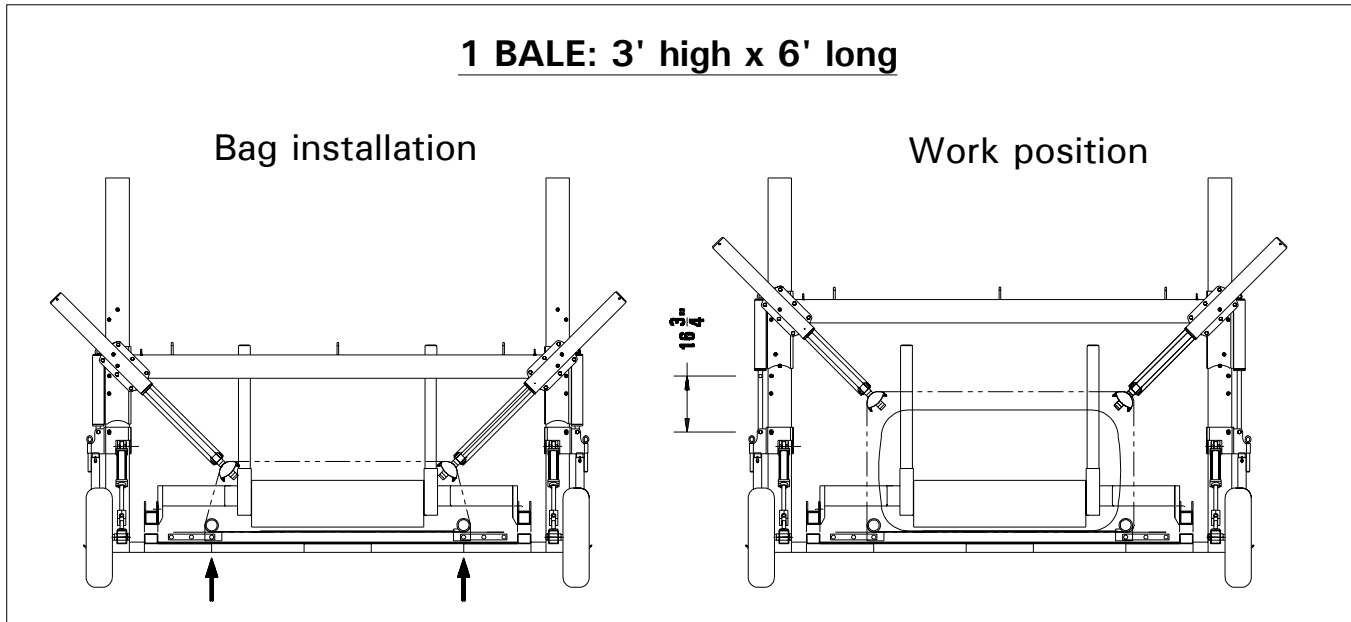

Figure 31

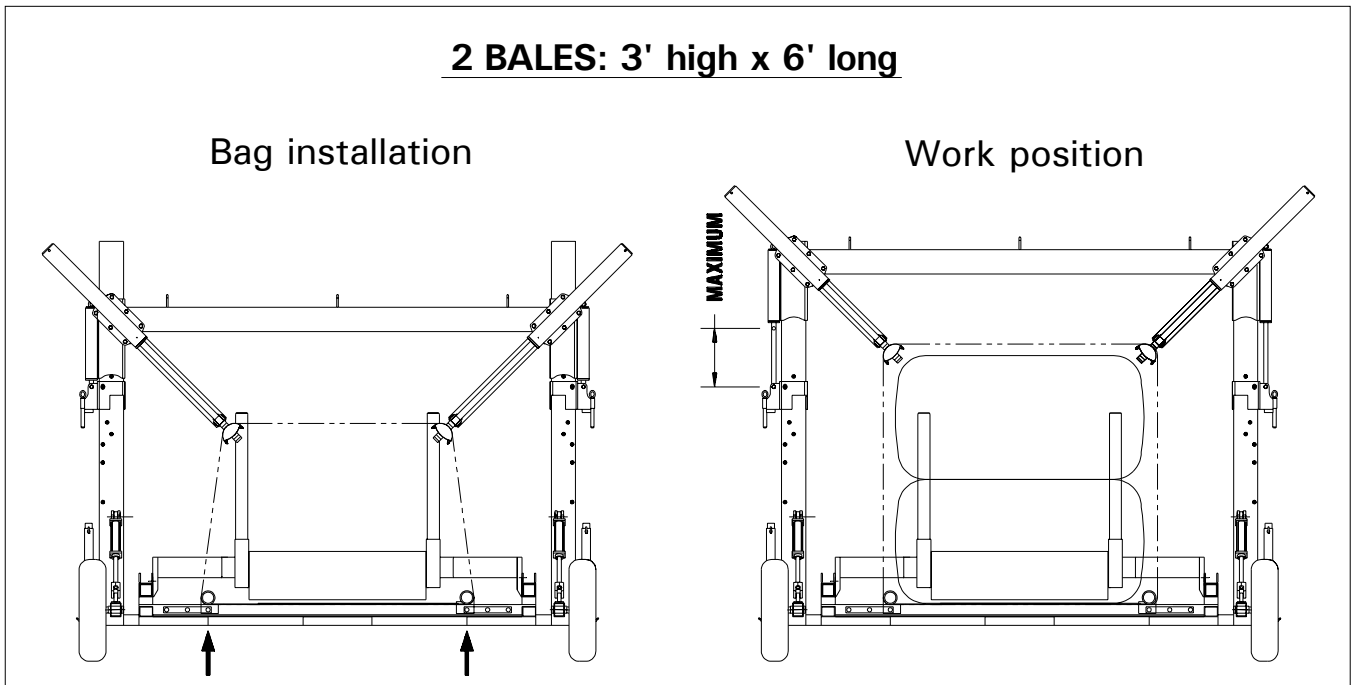

Figure 32

OPERATION (cont'd)

HEIGHT ADJUSTMENT OF THE MOBILE ARCH

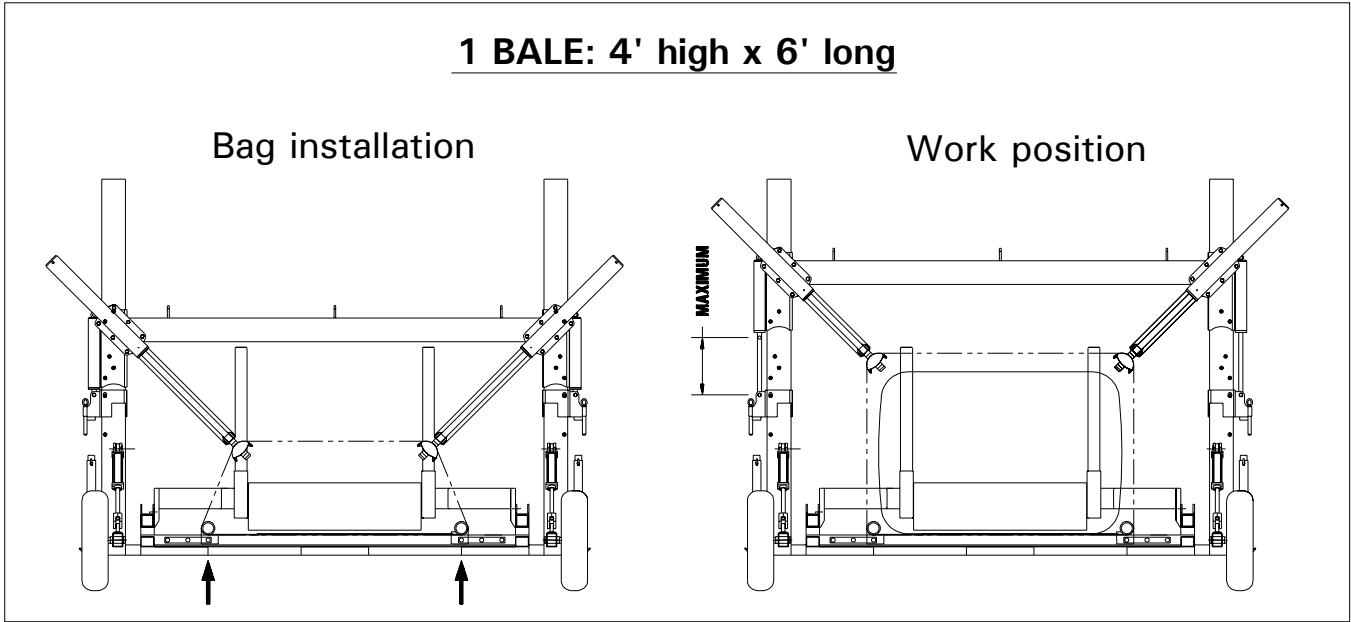

Figure 33

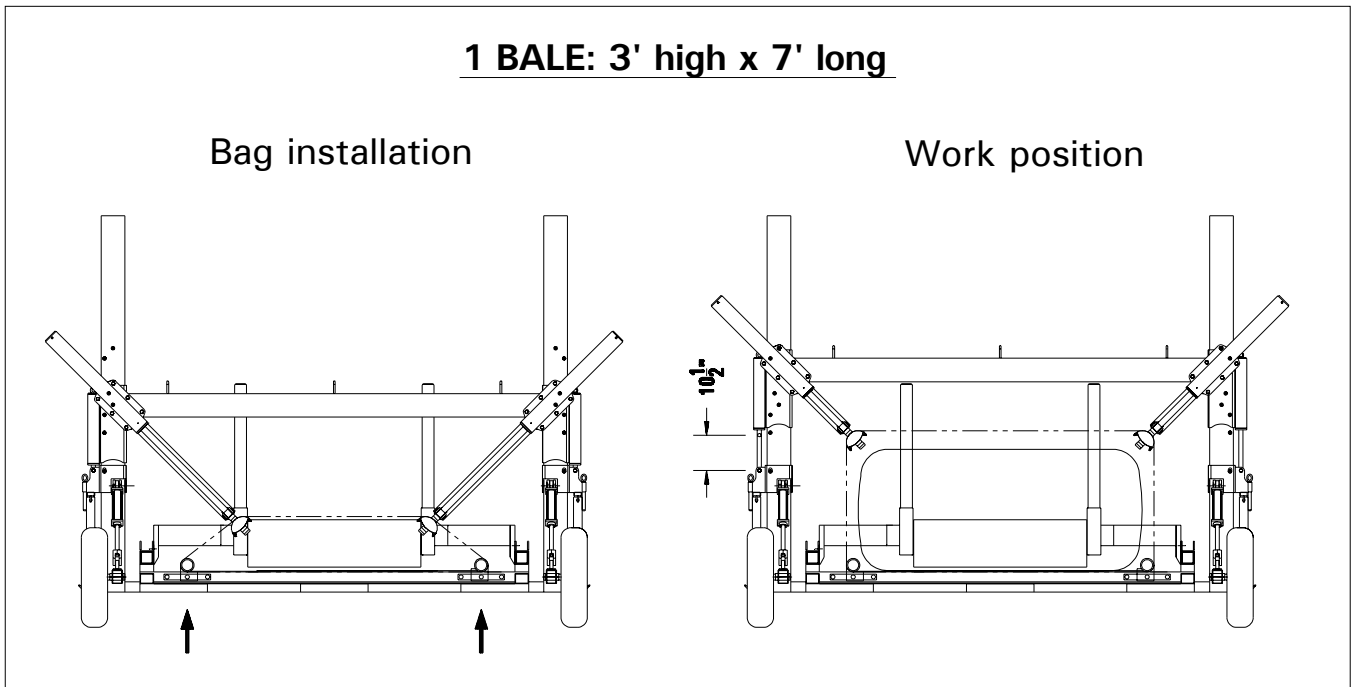

Figure 34

OPERATION (cont'd)

HEIGHT ADJUSTMENT OF THE MOBILE ARCH

4

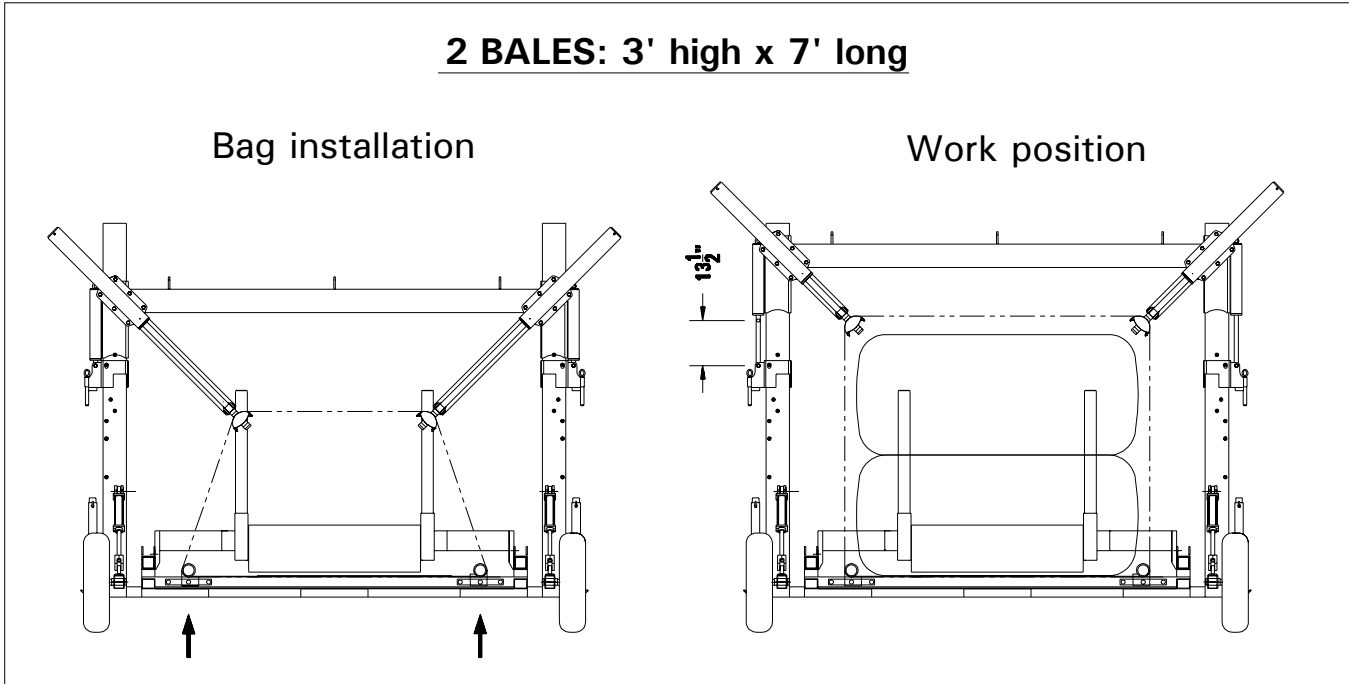

Figure 35

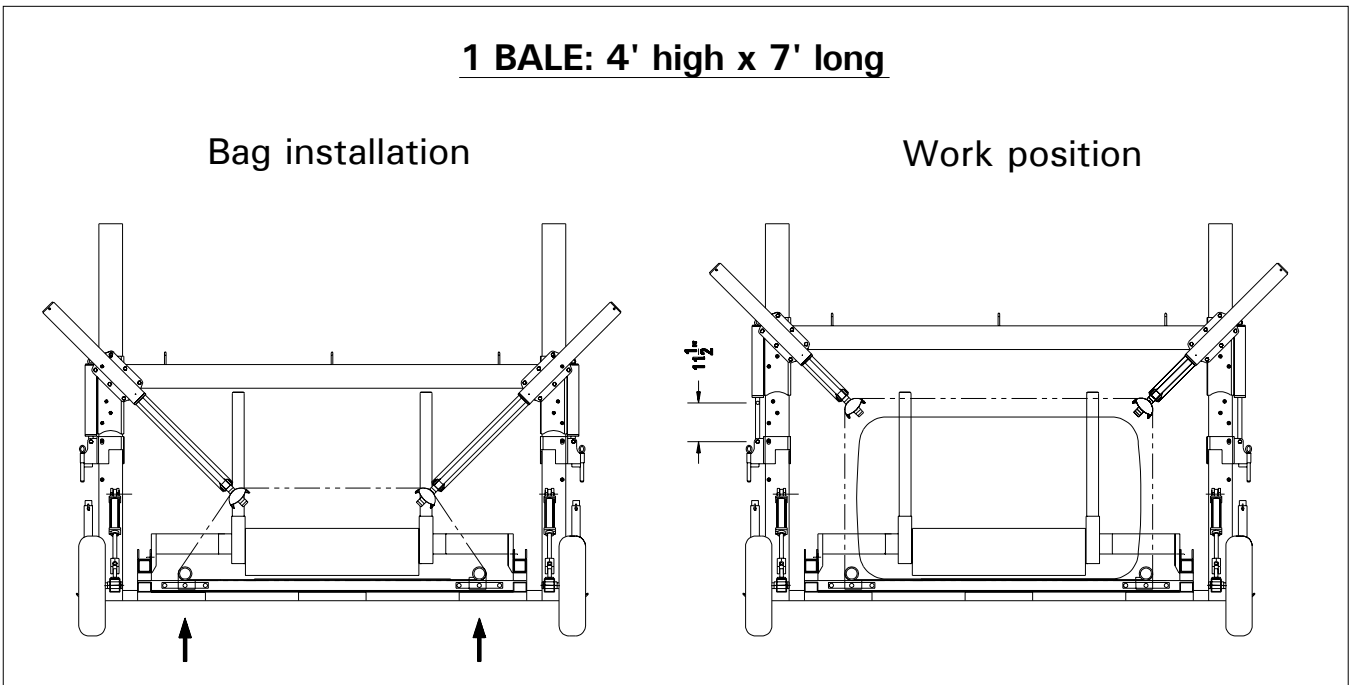

Figure 36

OPERATION (cont'd)

HEIGHT ADJUSTMENT OF THE MOBILE ARCH

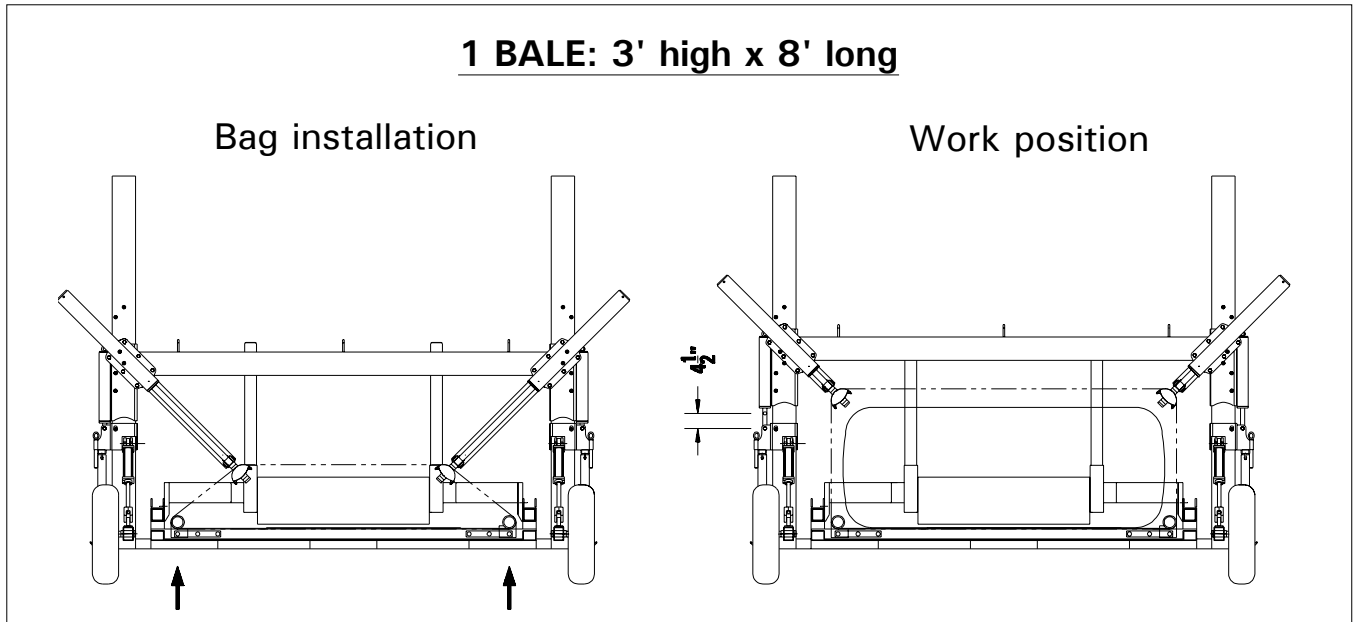

Figure 37

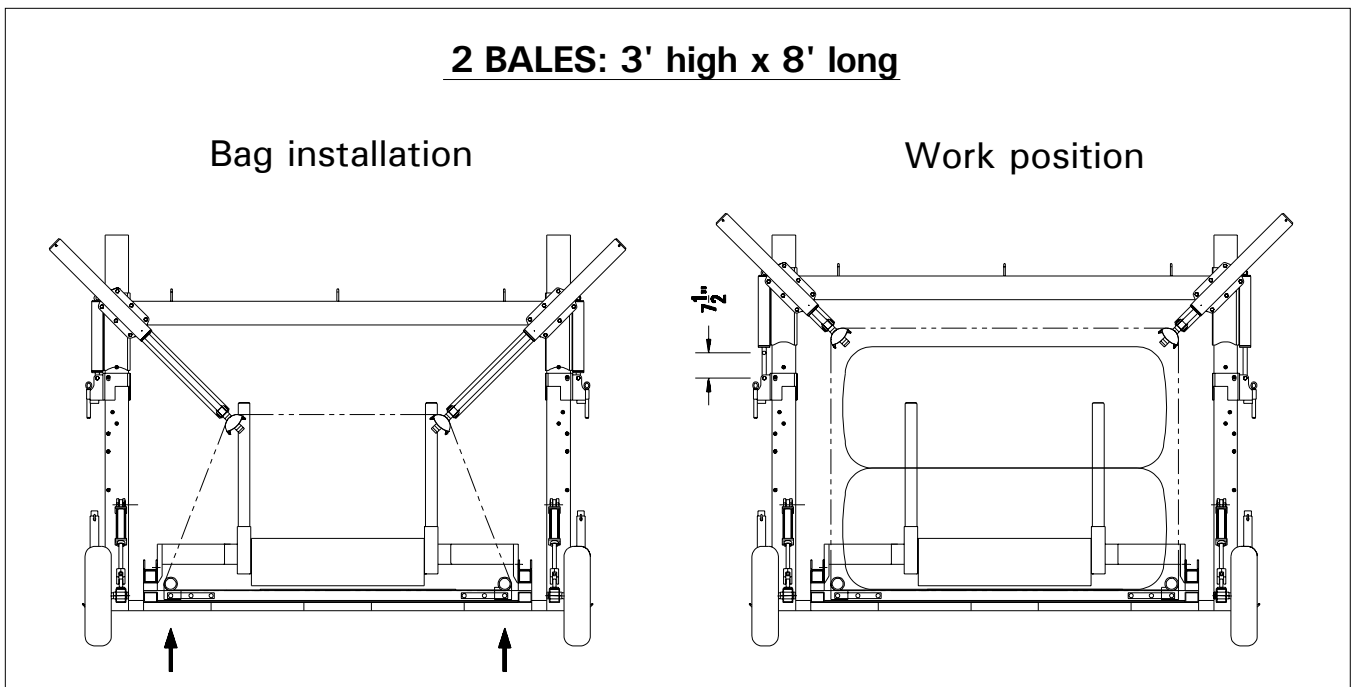

Figure 38

OPERATION (cont'd)

HEIGHT ADJUSTMENT OF THE MOBILE ARCH

4

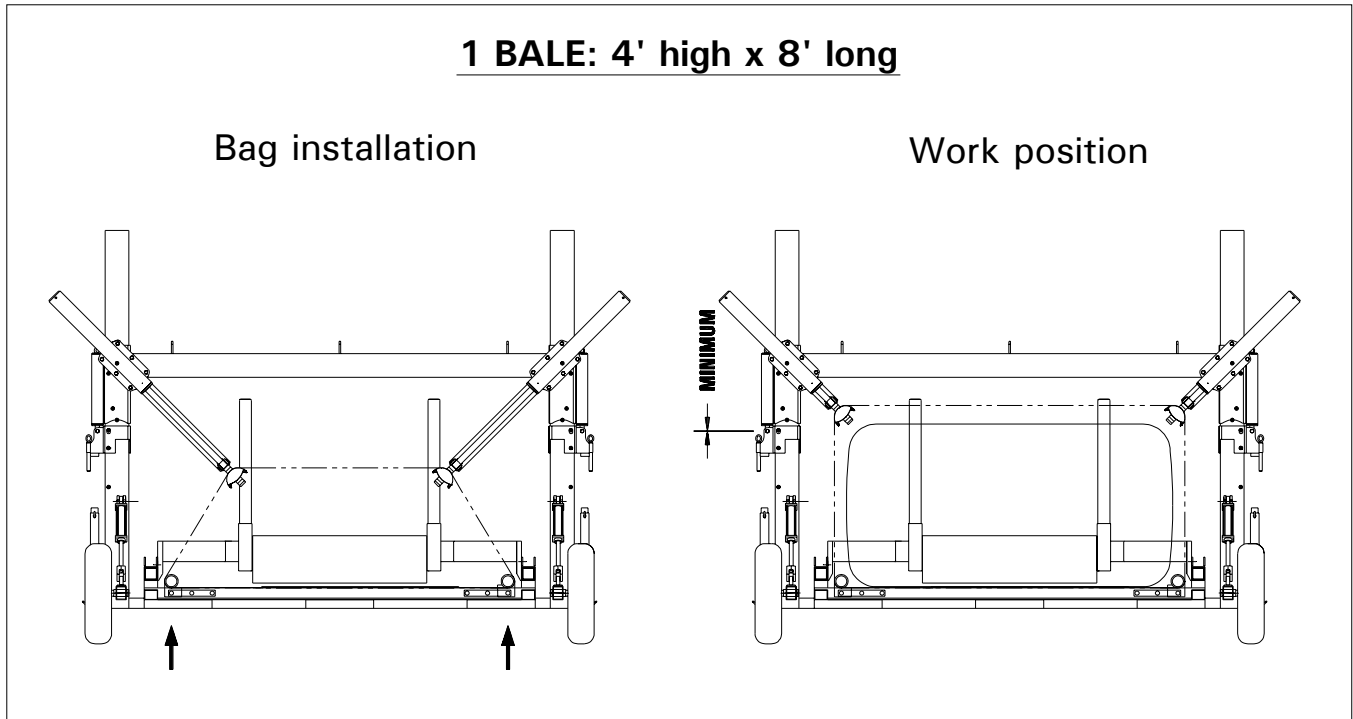

Figure 39



Figure 40

GROUND PREPARATION

- 1) Choose a dry and well drained area.
- 2) Level and clean up site where the tubes will be used.
- 3) If possible, provide a sand bed of 2" to 3" (5-8 cm) thick (Fig. 40). This will help reduce damage from rodents.

OPERATION (cont'd)



Fig. 41



Figure 42



Figure 43

- 1) Locate the rear end of the SilaTube approximately 5' (152 cm) away from the point where you want to position the end of the tube. This will compensate if there is some slippage of the first couple of bales until there is enough ground friction to push the SilaTube forward.
- 2) Start engine.
- 3) For maximum operating speed, you may set the engine to full throttle, although it is preferable to run it a speed closer to your rate of bale supply to machine. This will result in a more economical operation.
- 4) Pull out the tube support plate (Fig. 41).
- 5) Remove the tube from its box, lay it flat on the ground and roll up the two ends towards center. Place the tube at the center of the support plate and unroll each side. Place it so that the tube name is facing outside when it unfolds (Fig. 42).
- 6) Adjust the lateral stretcher arms according to the bale dimensions and install tube on the stretcher arms.
- 7) Slide it carefully **to the bottom** of the stretcher arms and under the U-shaped bale guide.
- 8) Be careful to remove all wrinkles, since they could cause some tearing of the tube.
- 9) Open the two lateral stretchers in order to apply a **slight amount of tension** to the tube (Fig. 43).
- 10) Return the tube support plate to its closed position. **ATTENTION:** It is very important that you proceed to step 8 before this one because you can cause some tearing of the tube by closing the tube support plate.
- 11) Again check the tube position and eliminate any wrinkles. Next, cut off all ties as shown.

OPERATION (cont'd)

4



Figure 44



Figure 45

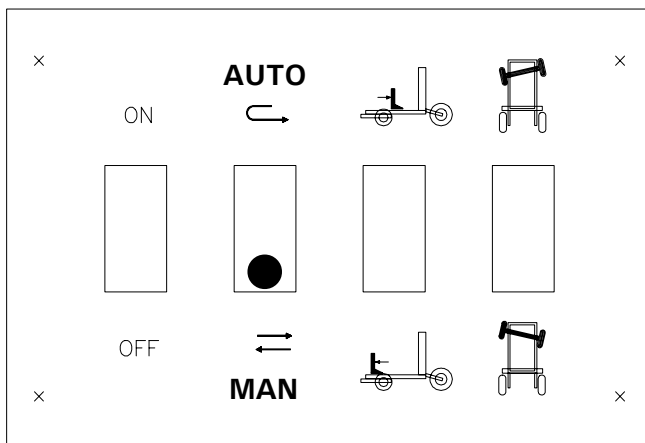

Figure 46

- 12) Apply a light tension to the tube, pull out the outer ply of plastic for approximately 18" (45 cm) (Fig. 44) and replace it on the tip of stretchers (Fig. 45). In this way, it will be easier to pull out when it will be time to close the end of the tube.
- 13) You will finish to stretching the tube after the introduction of the first bales in the SilaTube.
- 14) Before introducing the first bales, place the switch for the pusher on manual mode (Fig. 46).
- 15) Operate the control valve manually until the first stack of bales goes beyond the stretchers ends by about 6" (15 cm).
- 16) **CLOSING OF THE END OF TUBE:** Let the two stretchers going inward until they touch lightly the bales. In this way, the plastic will be easier to slide. Pull out enough plastic to close, and tie the tube properly as shown (Fig. 47). **Do not forget:** stretch the tube again to introduce freely the bales in the tube.



Figure 47

OPERATION (cont'd)



Figure 48



Figure 49



Figure 50

- 17) **STRETCH THE TUBE ONLY WHEN READY TO OPERATE.** It may lose some of its capacity to retract if kept stretched for a too long period of time. If you must stop loading bales for a while, **BRING THE TUBE DOWN TO A MODERATE TENSION.**
- 18) Adjust rear wheels in order to have a minimum amount of ground friction with the rear end of the SilaTube while keeping it in contact with the ground (Fig. 48).
- 19) Push the switch for pusher mode to automatic mode.
- 20) It is recommended to use a double spear on your loader to place the bales onto the SilaTube.
- 21) Place the required number of bale in each row before operate the pusher mechanism.
- 22) The pusher control and the steering control can be controlled from the remote control or from the control box.
- 23) After the first 8 or 10 bales, lift up lightly the rear wheels of the SilaTube to increase ground friction. This will ensure that the bales will be real tight against each other in the tube (Fig. 49).
- 24) Towards the end of the tube, keep at least 70" (178 cm) of plastic, in order to allow for proper closure of the tube.
- 25) To push the last bale into the tube, use the pusher folding extension in the pusher. Place it as shown (Fig. 50).

OPERATION (cont'd)



4 Figure 51



Figure 52

- 26) Push the bale with the pusher in manual mode in order to eject the last bale from SilaTube.
- 27) Fold the pusher extension.
- 28) Close up end of tube as previously described (Fig. 51).
- 29) Regularly inspect the tubes. If torn or punctured, repair openings with proper means.
- 30) It's possible to insert drawbar at the front of the SilaTube (Fig. 52) and travel off-road when wheels are in work position. An hydraulic jack permits raising the front of the machine.

MAINTENANCE

- 1) Refer to the manufacturer's instructions for the engine.
- 2) Use a high quality lithium base grease containing molybdenum disulfide (MoS_2) such as «Esso Unirex EP1 Moly», «DARINA XL-Multi Season Moly, Grade #1» from Shell or equivalent.
- 3) Wipe off all grease fittings with a clean cloth before adding grease in order to avoid injecting dirt or sand.
- 4) Repair or replace damaged grease fittings.
- 5) Lubricate stretcher arms guides every 20 hours of operation.
- 6) Lubricate all grease fittings every 20 hours of operation.
- 7) Open, clean and lubricate wheel bearings once a year.
- 8) Check oil level in hydraulic reservoir every 20 hours of operation. If necessary add good quality trans hydraulic oil such as «Trans Hydraulic Duratran» from Petro-Canada, «DONAX TD» from Shell or equivalent.
- 9) Change oil filter after the first 50 hours of operation and then every 250 hours. Use replacement filter no. K-22001, PRONOVOST part No. 32007.
- 10) Check all nuts and bolts once a year. If necessary use torque chart on page 50.
- 11) Check all bolts on wheels after first 5 hours of operation and then every 50 hours.
- 12) Check tire pressure every 50 hours. Adjust according to manufacturer's recommendation indicated on the tires.

STORAGE

- 1) Store the SilaTube in a cool, dry place.
- 2) Lower the SilaTube frame on wooden blocks.
- 3) Keep tires off the ground and cover them if left exposed to the sun.
- 4) Keep all piston rods in the retracted position. This will assure better protection against the elements.
- 5) Clean your SilaTube.
- 6) Touch-up or repaint if necessary.
- 7) Lubricate all points before storage.
- 8) Drain all fuel from tank and follow engine manufacturer's storage recommendations.

SPECIFICATIONS

SPECIFICATIONS SILATUBE P-6500

Overall length at work: 102½" without tongue
Overall length in transport: 138 3/8" without tongue
Overall width at work: 147 7/8"
Overall width in transport: 118"
Overall height in transport: 122"
Stack height: 36" to 72"
Square bale lengths: 72", 84" or 96"
Engine: HONDA 20 HP
Electric starting: Standard
Double hyd. pump: 18 gal at 2800 psi
Front hub (cap. - bolts): 2500 lbs (1136 kg) - 5
Rear hub (cap. - bolts): 4000 lbs (1814 kg) - 6

Front rim (dim. - bolts): 12" x 7" - 5
Rear rim (dim. - bolts): 16" x 6" - 6
Front tires (with tube): 23.5"x8.5"x12"-10 plys
Rear tires (with tube): 235/85R16
Oil tank capacity: 13 gal US (10.83 gal imp)
Hyd. steering adjustment: Standard
Working lights: Option (P-6545)
Road lights: Option (P-6540)
Motorized moving kit: Standard
Hitch weight (app.): 2500 lbs
Total weight (app.): 7100 lbs

Design and specifications subject to change without notice.

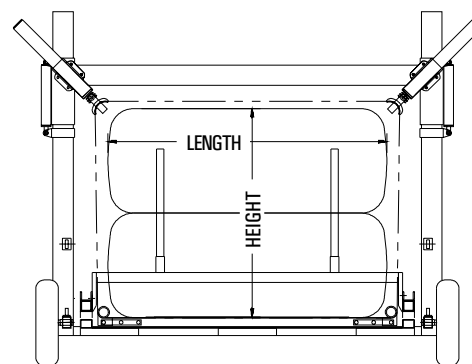

7

Stack height + Bale lengths – 8" (round corners) = **HALF-PERIMETER**

Silatube	HALF-PERIMETER	Tube dimension	Tube thickness
P-6500	For half-perimeter 102" to 120" (2.59 to 3.05 m)	100" (2.54 m) lay flat	0.004 mil.
P-6500	For half-perimeter 115" to 136" (2.92 to 3.54 m)	113" (2.87 m) lay flat ❶	0.004 mil.
P-6500	For half-perimeter 136" to 158" (3.51 to 4.01 m)	132" (3.35 m) lay flat ❷	0.005 mil.
P-6500	For half-perimeter 150" to 160" (3.81 to 4.06 m)	144" (3.66 m) lay flat ❸	0.005 mil.

- ❶ For bales 72" high x 60" long.
- ❷ For bales 72" high x 84" long.
- ❸ For bales 72" high x 96" long.

SILATUBE P-6500 ASSEMBLY

170-02891

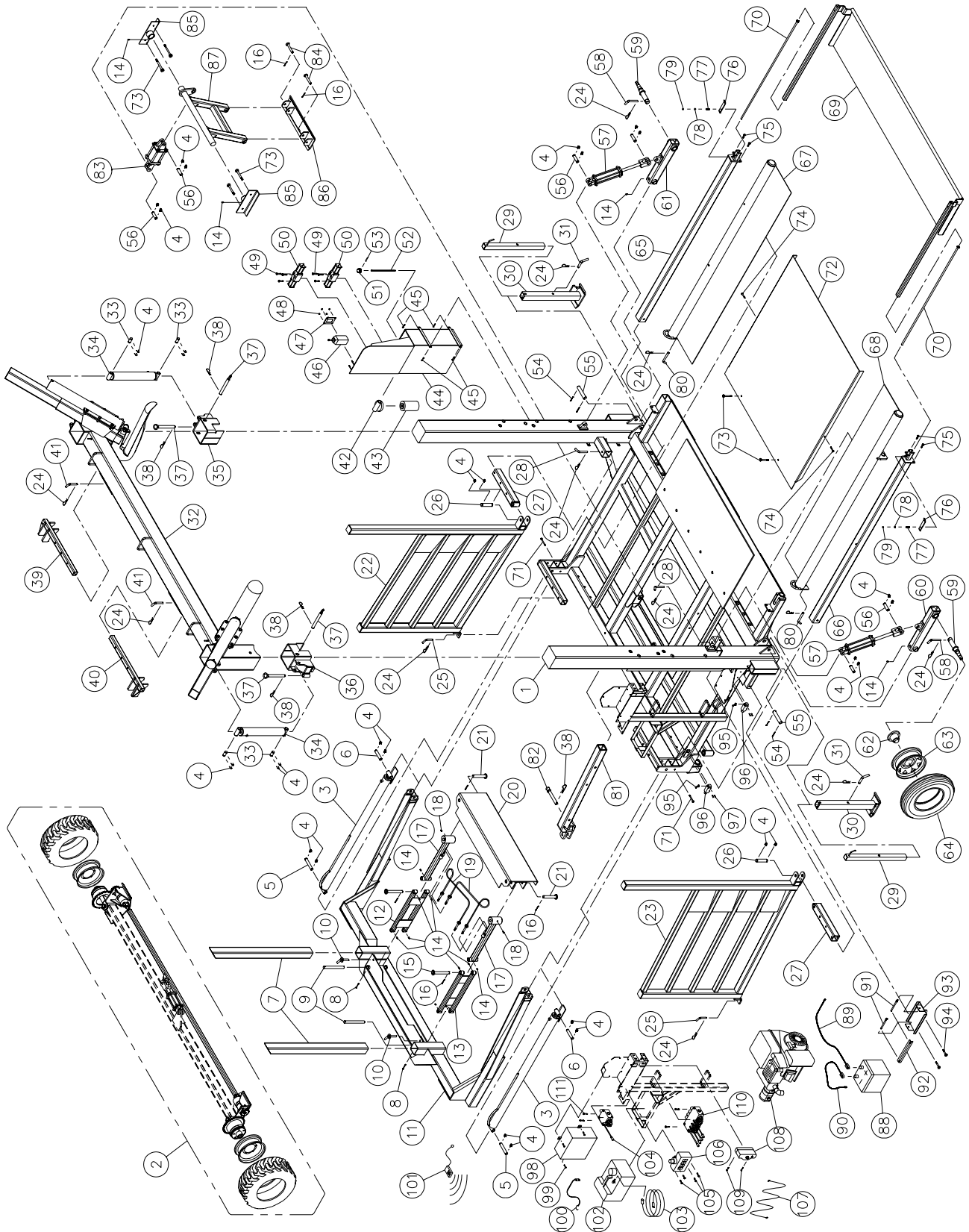

SILATUBE P-6500 ASSEMBLY (cont'd)

REF.	PART #	DESCRIPTION	QTY
1	120-04061	Frame	1
2	170-03201	Traction mechanism assembly (ref p. 32)	1
3	30I60	Cylinder 3"dia x 60" stroke (ref p. 37)	2
4	Std.	Hairpin cotter 7/8"	32
5	150-04011	Pin 1" x 6 3/16" lg.	2
6	150-04001	Pin 1" x 5 3/16" lg.	2
7	110-18411	Pusher post	2
8	300-32340	Bolt 1/4" NC x 2" lg. + nylon locknut	2
9	150-03901	Pin	2
10	110-20411	Extractor lock	2
11	120-04051	Pusher	1
12	110-18161	Right front extractor arm	1
13	110-18162	Left front extractor arm	1
14	Std.	Grease fitting 1/4"-28 straight	14
15	110-18651	Pin	2
16	Std.	Cotter pin 5/32" x 1 3/4" lg.	6
17	110-18151	Rear extractor arm	2
18	Std.	Grease fitting 1/4"-28 90 deg.	2
19	110-19601	Extractor stabilizer + 2 nylon locknut 5/8" NC	2
20	110-18631	Extractor	1
21	110-18641	Pin	2
22	120-03991	Righ lateral guide	1
23	120-03992	Left lateral guide	1
24	Std.	Hitch pin clip 5/32" x 2 3/4" lg.	12
25	150-03961	Front pin	2
26	150-04191	Rear pin	2
27	110-18181	Lower guide bracket	2
28	150-03971	Pin	2
29	110-18421	Stand inner tube	2
30	110-18391	Stand outer tube	2
31	150-04081	Pin	2
32	170-03181	Moving part of the arch (ref. p. 33)	1
33	32160	Pin 1" x 5 1/4"	4
34	30HL17	Cylinder 3" dia. x 17" stroke (ref. p. 38)	2
35	110-17721	Right mounting bracket	1
36	110-17722	Left mounting bracket	1
37	110-18171	Pin	4
38	Std.	Hitch pin clip 3/16" x 3 1/4" lg.	5
39	110-18111	Right upper guide bracket	1
40	110-18112	Left upper guide bracket	1
41	150-03981	Pin	2
42	32031	Hydraulic oil filter adaptor	1
43	32007	Paper filter K-22001	1
44	110-18541	Oil reservoir	1

SILATUBE P-6500 ASSEMBLY (cont'd)

REF.	PART #	DESCRIPTION	QTY
45	300-36250	Bolt 3/8" NC x 1" lg. + nylon locknut	4
46	32263	Relief valve	1
47	130-07881	Relief valve retaining plate	1
48	346-32000	Nylon locknut 1/4" NC	4
49	300-36430	Bolt 3/8" x 3 1/2" lg + nylon locknut	6
50	18019	Solenoid valve	2
51	32029	Oil reservoir cap	1
52	32030	Dip stick	1
53	Std.	Spring pin 5/32" dia. x 1 3/4" lg.	1
54	Std.	Cotter pin 5/32" x 2" lg.	4
55	150-03731	Pin for rear axle	2
56	D-60051	Pin 1" dia x 3" lg.	6
57	190-04711	Cylinder 2 1/2" dia x 8" stroke (see p. 40)	2
58	150-03721	Rear axle pin	2
59	110-17681	Removable rear axle	2
60	110-17672	Left rear axle	1
61	110-17671	Right rear axle	1
62	32218	Hub H-2500	2
63	R-1575RT	Rim	2
64PN-22575D15		Tire ST225/75D15	2
65	110-18091	Right pusher slide	1
66	110-18092	Left pusher slide	1
67	110-18121	Right hand bale guide	1
68	110-18122	Left hand bale guide	1
69	110-18451	Tube support plate	1
70	110-18601	Travel limiter rod + nut 1/2" NC	2
71	300-40580	Bolt 1/2" NC x 6" lg. + nylon locknut	2
72	130-22571	Bale support pan	1
73	300-40520	Bolt 1/2" NC x 5" lg. + nylon locknut	6
74	300-40400	Bolt 1/2" NC x 3" lg. + nylon locknut	2
75	300-40310	Bolt 1/2" NC x 1 1/2" lg. + nylon locknut	4
76	110-17831	Tube support plate lock	2
77	32130	Compression spring 13/32" x 3/4" lg.	2
78	376-32000	Flat washer 1/4"	2
79	346-20000	Nylon locknut 1/4" NC	2
80	150-03991	Pin	2
81	110-18671	Drawbar	1
82	150-04871	Pin	1
83	40TRO4	Cylinder 4" dia.x 4" stroke (see p. 35)	1
84	110-18551	Pin	2
85	110-18561	Jack bracket	2
86	110-18571	Jack plate	1
87	110-18581	Jack frame	1
88	32283	Battery 12V - 540 AMP	1
89	51606	Battery cable 4G x 30" lg	1
90	32291	Battery cable 4G x 15" lg	1

SILATUBE P-6500 ASSEMBLY (cont'd)

REF.	PART #	DESCRIPTION	QTY
91	110-11511	Hold down rod + nylon locknut 3/8" NC & 7/16" NC	2
92	130-05751	Battery hold down	1
93	110-18531	Battery support	1
94	300-36460	Bolt 3/8" NC x 4" lg + nylon locknut	2
95	32271	Limit switch lever	2
96	32254	Limit switch	2
97	327-20310	Hexagonal socket head set screw 10-24 x 1 1/2" lg + nylon locknut	4
98	32253	Master sealed box	1
99	300-32250	Bolt 1/4" NC x 1" lg. + nylon locknut	3
100	825-150	Rubber band 15"	1
101	32255	Transmitter 4 channel	1
102	32267	Gaz tank + quick coupler	1
103	190-05611	Gaz line 5/16" i.d. + quick coupler	1
104	32289	1 spool control valve	1
105	300-32220	Bolt 1/4" NC x 3/4" lg + nylon locknut	4
106	32245	Manual control sealed box	1
107	32265	Switch cable	1
108	32266	Motor HONDA 20HP + switch control box	1
109	Std.	Bolt 10-24 x 3/4" lg + nylon locknut	2
110	32288	4 spool control valve (adjusted at 2800 psi)	1
111	300-34370	Bolt 5/16" NC x 2 1/2" lg + nylon locknut	4

MOTORIZED MOVING KIT

170-03201

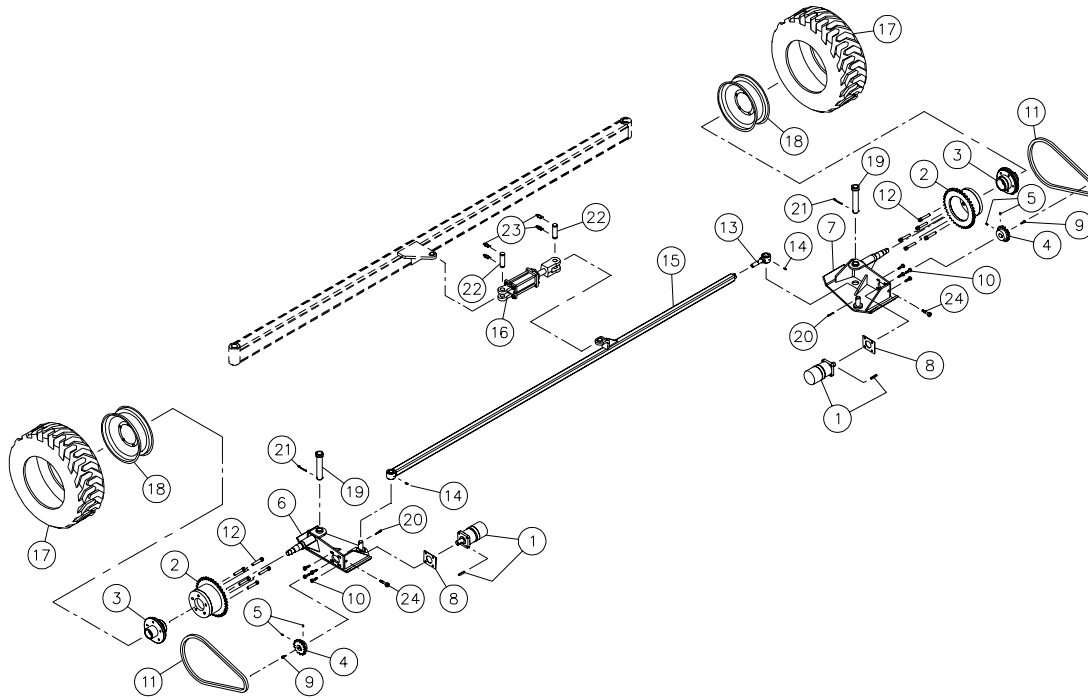

REF.	PART #	DESCRIPTION	QTY
1	DH315	Hydraulic motor DH315 + key	2
2	110-08841	Sprocket 60A38	2
3	190-01281	Hub H2500 modified	2
4	110-10981	Sprocket 60B14	2
5	323-34190	Hexagonal socket set screw 5/16" NC x 1/2" lg.	4
6	110-18072	Left wheel mounting plate	1
7	110-18071	Right wheel mounting plate	1
8	130-14511	Motor plate	2
9	300-32220	Bolt 1/4" NC x 3/4" lg. + spring washer	2
10	300-36280	Bolt 3/8" NC x 1 1/4" lg. + flat washer & spring washer	8
11	190-02881	Chain #60 x 36" lg.	2
12	110-10991	Bolt 1/2" NF x 2 3/4" lg. + nut	10
13	110-18021	Steering adjustment + nut 3/4" NC	1
14	Std.	Grease fitting 1/4"-28 straight	2
15	110-18011	Steering rod	1
16	25TR04	Cylinder 2 1/2" x 4" stroke	1
17	PNA238512	Traction tire	2
18	110-20401	Rim 12 x 7 - 5 bolts	2
19	110-18491	Pin	2
20	Std.	Cotter pin 3/16" x 1 3/4" lg.	2
21	Std.	Cotter pin 5/32" x 2" lg.	2
22	D-60051	Pin 1" x 3" lg.	2
23	Std.	Hair pin 7/8"	2
24	300-40250	Bolt 7/16" NC x 1 3/4" lg + nylon locknut	2

8

DETAIL OF ARCH P-6500

170-03181

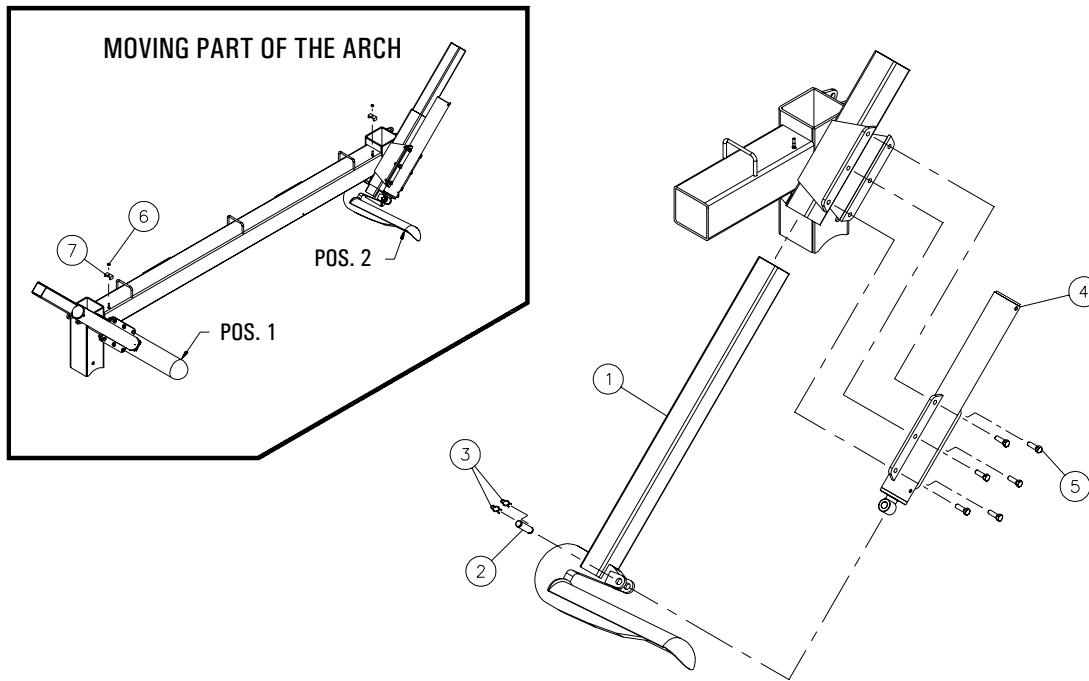

REF.	PART #	DESCRIPTION	QTY	POS. #	Arch
			1	2	
1	110-17551	Stretcher arm	1	1	-
2	150-03641	Pin 1" x 3 5/8" lg	1	1	-
3	Std.	Hair pin 7/8"	2	2	-
4	40Z30	Cylinder	1	1	-
5	300-44340	Bolt 5/8" NC x 2" lg + nylon locknut	6	6	-
6	346-34000	Nylon locknut 5/16" NC	-	-	2
7	8295	Hoses retaining plate	-	-	2

CYLINDER 25TR04 & 25TR08

170-01811

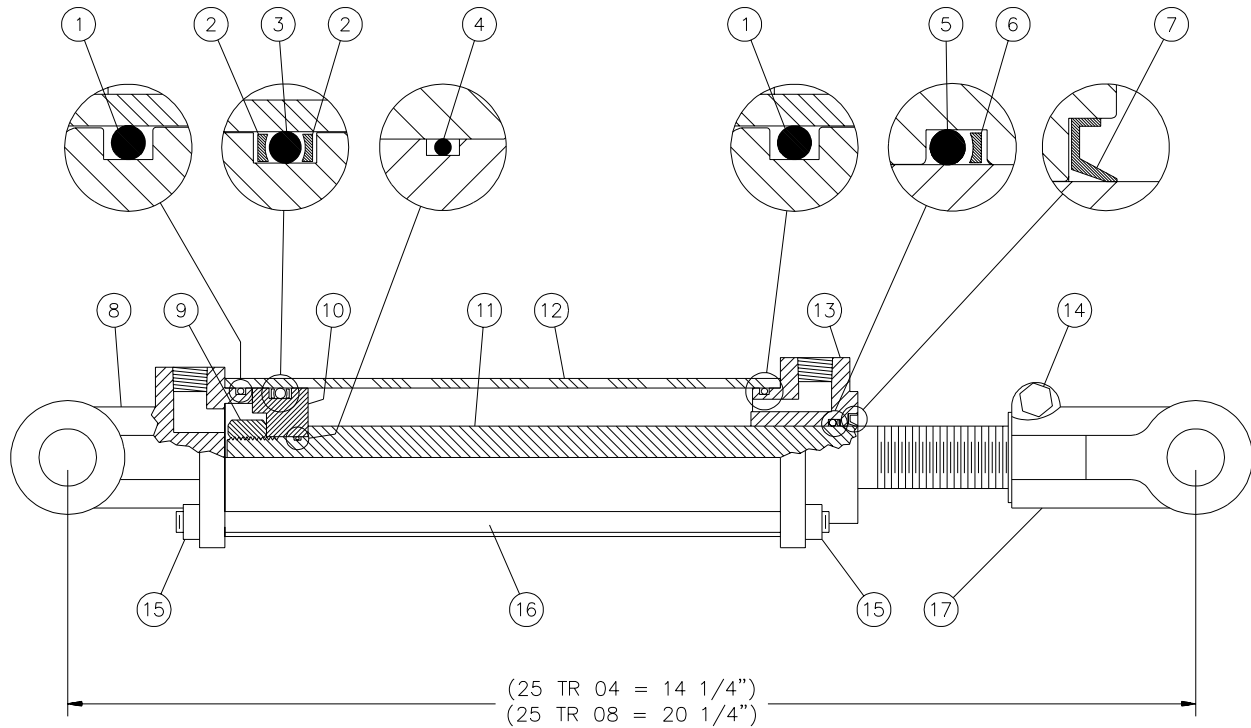

REF.	PART #	DESCRIPTION	QTY	
			25TR04	25TR08
1	Voir RK25TR	O-ring 1/8" x 2 1/4" x 2 1/2"	2	2
2	Voir RK25TR	Back-up 2 1/2" o.d. x 1/8" ø	2	2
3	Voir RK25TR	O-ring 3/16" x 2 1/8" x 2 1/2"	1	1
4	Voir RK25TR	O-ring 1/16" x 5/8" x 3/4"	1	1
5	Voir RK25TR	O-ring 1/8" x 1 1/8" x 1 3/8"	1	1
6	Voir RK25TR	Back-up 1 3/8" o.d. x 1/8" ø	1	1
7	Voir RK25TR	Wiper 1 1/8" i.d. x 1 5/8" o.d.	1	1
8	492401	Yoke (for 2 1/2" tube)	1	1
9	Std.	Nut 3/4" NF	1	1
10	4924-31	Piston 2 1/2" ø	1	1
11	491980-04	Piston rod 1 1/8"	1	-
11	492028	Piston rod 1 1/8"	-	1
12	491668-04	Cylinder body 2 1/2" ø	1	-
12	491668	Cylinder body 2 1/2" ø	-	1
13	492421	Head (for 2 1/2" tube)	1	1
14	Std.	Bolt 3/8" NC x 2 1/4" + nut	1	1
15	Std.	Nut 3/8" NC	8	8
16	Std.	Threaded rod 3/8" NC 8 3/8" lg	4	-
16	Std.	Threaded rod 3/8" NC 12 3/8" lg	-	4
17	458599	Yoke (for 1 1/8" rod)	1	1
NI*	8183	Pin 1" ø + cotter pin	2	2
NI*	RK25TR	Repair kit for cylinder 2 1/2" (includes # 1, 2, 3, 4, 5, 6, & 7)	1	1

*NI = NON ILLUSTRÉ

8

CYLINDER 40TR04

170-03141

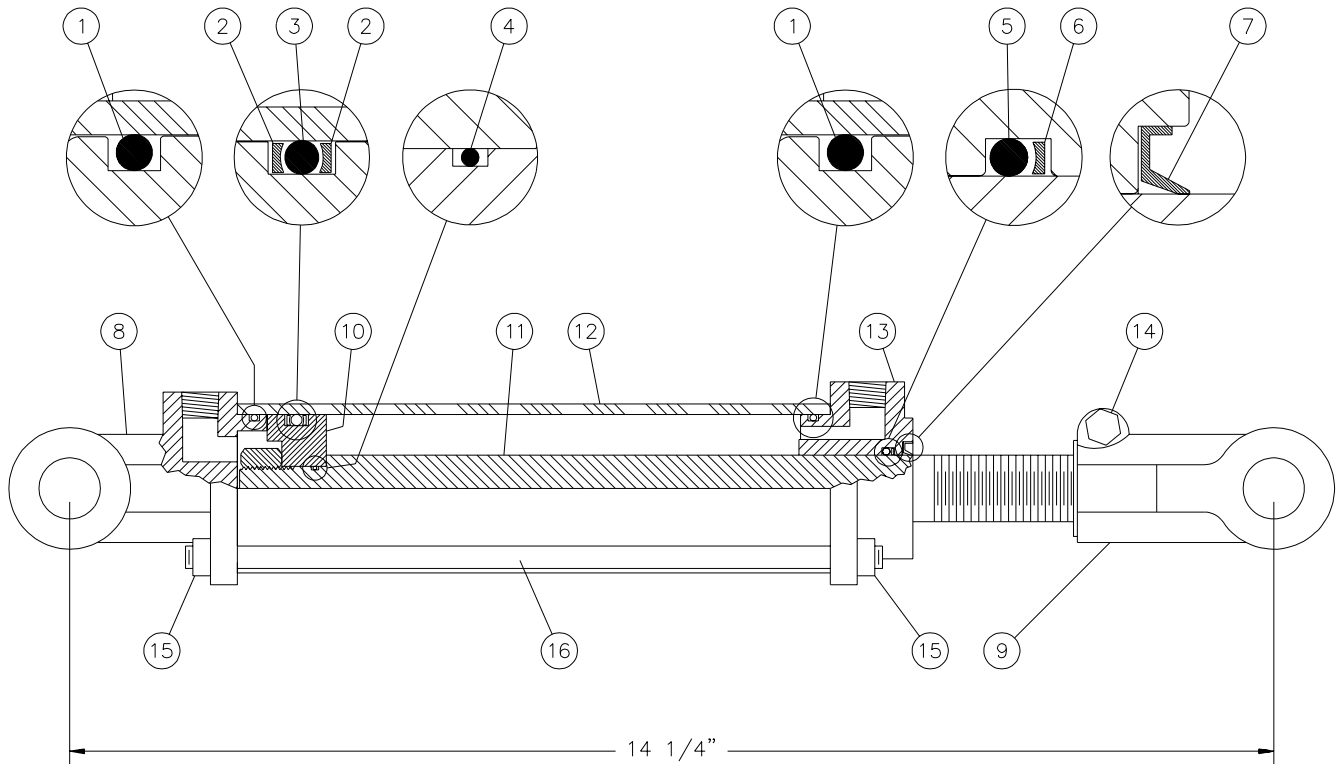

REF.	PART #	DESCRIPTION	QTY
1	See RK40TR	O-ring	2
2	See RK40TR	Back-up	2
3	See RK40TR	O-ring	1
4	See RK40TR	O-ring	1
5	See RK40TR	O-ring	1
6	See RK40TR	Back-up	1
7	See RK40TR	Wiper	1
8	492404	Yoke (for 4" tube)	1
9	- - -	Yoke (for 1 1/4" rod)	1
10	4924-34	Piston 4" ø	1
11	- - -	Piston rod 1 1/4"	1
12	- - -	Cylinder body 4" ø	1
13	492424	Head (for 2 1/2" tube)	1
14	Std.	Bolt 3/8" NC x 2 1/4" + nut	1
15	Std.	Nut 3/8" NC	8
16	Std.	Threaded rod 3/8" NC 8 3/8" lg	4
NI*	8183	Pin 1" ø + cotter pin	2
NI*	RK40TR	Repair kit for cylinder 4" (includes # 1, 2, 3, 4, 5, 6, & 7)	1

*NI = NOT ILLUSTRATED

8

ARCH CYLINDER 40Z30

170-03151

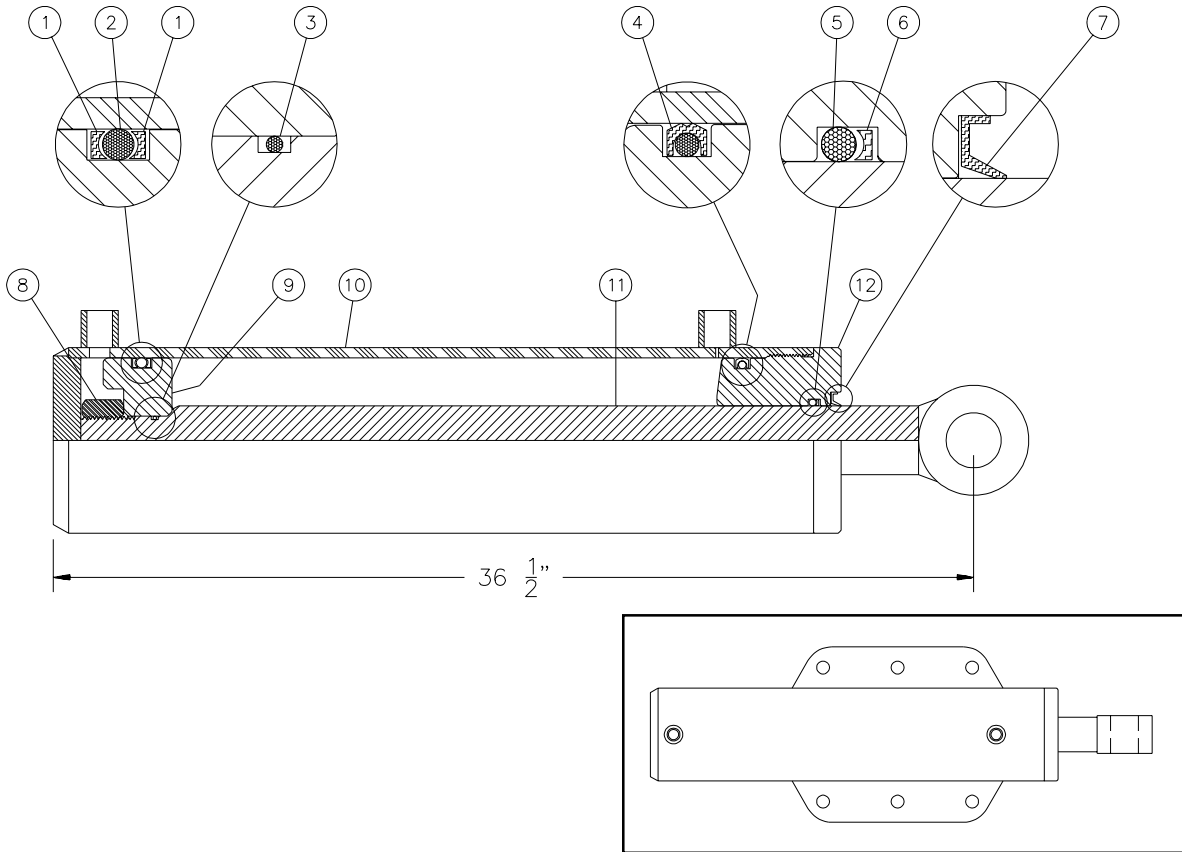

REF.	PART #	DESCRIPTION	QTY
1	BU-342	Back-up ring 3/16" x 3 5/8" x 4"	2
2	OR-342	O-ring 3/16" x 3 5/8" x 4"	2
3	OR-024	O-ring 1/16" x 1 1/8" x 1 1/4"	1
4	PSP-342	O-ring "heavy duty" 3/16" x 3 5/8" x 4"	1
5	OR-224	O-ring 1/8" x 1 3/4" x 2"	1
6	BU-224	Back-up ring 1/8" x 1 3/4" x 2"	1
7	CR17240	Wiper 5/16" x 1 3/4" x 2 1/4"	1
8	Std.	Nut 1 1/4" NF	1
9	D-6053	Piston 4" dia.	1
10	110-17521	Cylinder body 4"	1
11	110-17511	Piston rod 1 3/4"	1
12	6052	Head 4" dia.	1
NI	32284	Repair kit for cylinder (includes # 1 to 7)	1

NI = Not illustrated

8

PUSHER CYLINDER # 30I60

170-03161

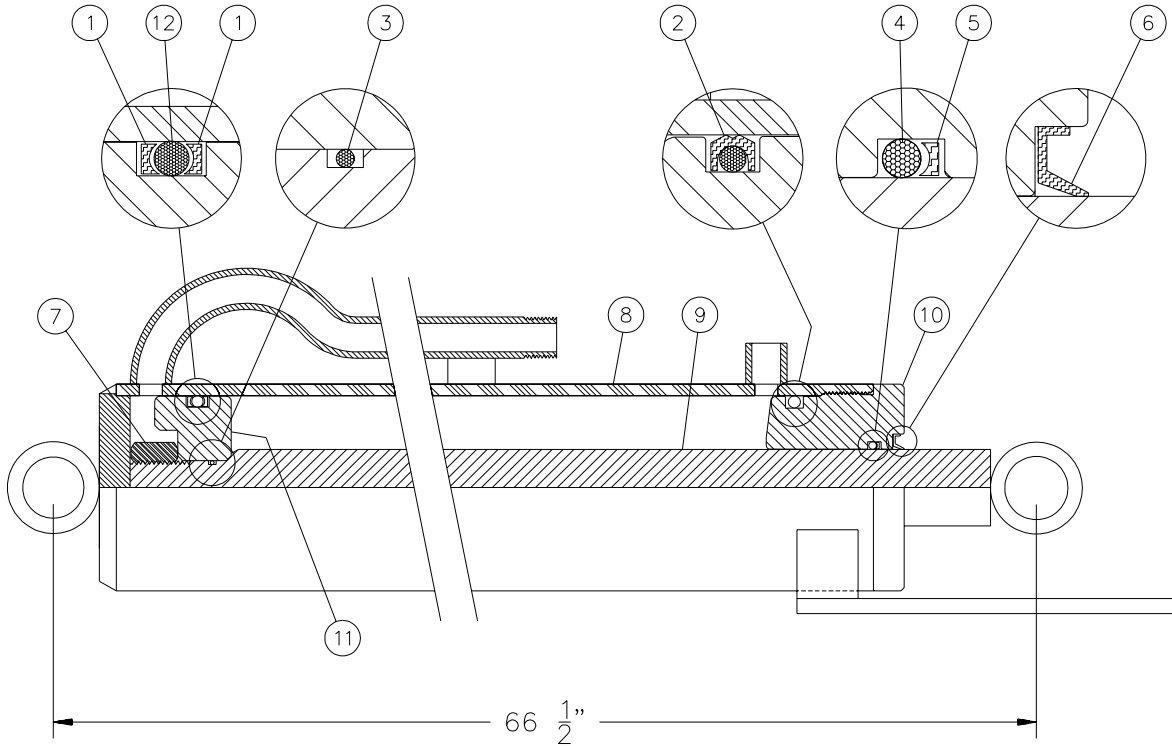

REF.	PART #	DESCRIPTION	QTY
1	BU-334	Back-up ring 3/16" x 2 5/8" x 3"	2
2	PSP-334	O-ring "heavy duty" 3/16" x 2 5/8" x 3"	1
3	OR-018	O-ring 1/16" x 3/4" x 7/8"	1
4	OR-224	O-ring 1/8" x 1 3/4" x 2"	1
5	BU-224	Back-up ring 1/8" x 1 3/4" x 2"	1
6	CR17240	Wiper 5/16" x 1 3/4" x 2 1/4"	1
7	Std.	Nut 7/8" NF	1
8	110-18131	Cylinder body 3" dia.	1
9	110-17571	Piston rod 1 3/4" dia.	1
10	150-04111	Head 3" dia.	1
11	D-6000	Piston 3" dia.	1
12	OR-334	O-ring 3/16" x 2 5/8" x 3"	1
NI*	32285	Repair kit for cylinder (includes # 1 to 6 & 12)	1

*NI = Not illustrated

8

CYLINDER 30HL17

170-03171

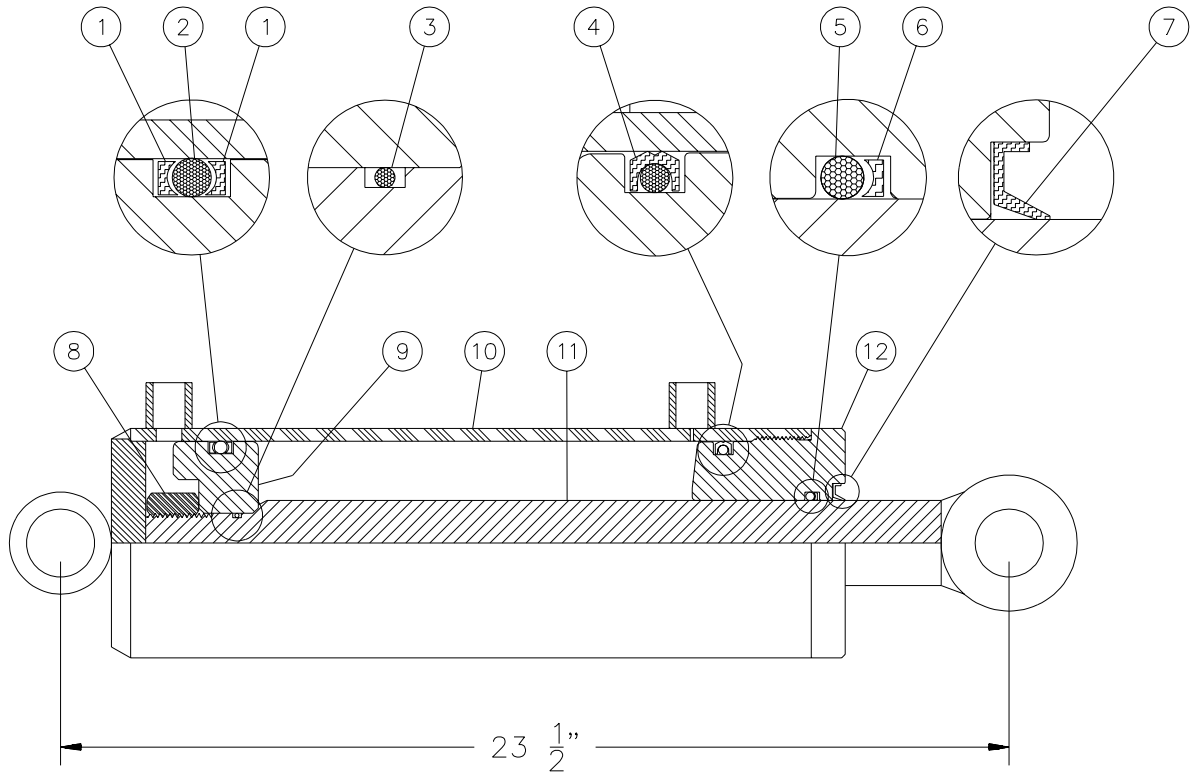

REF.	PART #	DESCRIPTION	QTY
1	BU-334	Back-up 3/16" x 2 5/8" x 3"	2
2	OR-334	O-ring 3/16" x 2 5/8" x 3"	2
3	OR-018	O-ring 1/16" x 3/4" x 7/8"	1
4	PSP-334	O-ring "heavy duty" 3/16" x 2 5/8" x 3"	1
5	OR-218	O-ring 1/8" x 1 1/4" x 1 1/2"	1
6	BU-218	Back-up 1/8" x 1 1/4" x 1 1/2"	1
7	CR12330	Wiper 1/8" x 1 1/4" x 1 1/2"	1
8	Std.	Nut 7/8" NF	1
9	D-6000	Piston 3" dia.	1
10	110-19501	Cylinder body 3"	1
11	110-17591	Piston rod 1 1/4"	1
12	D-6093	Head 3" dia.	1
NI	32204	Repair kit for cylinder (includes # 1 to 7)	1

NI = Not illustrated

8

CONTROL VALVE SD5

170-01841

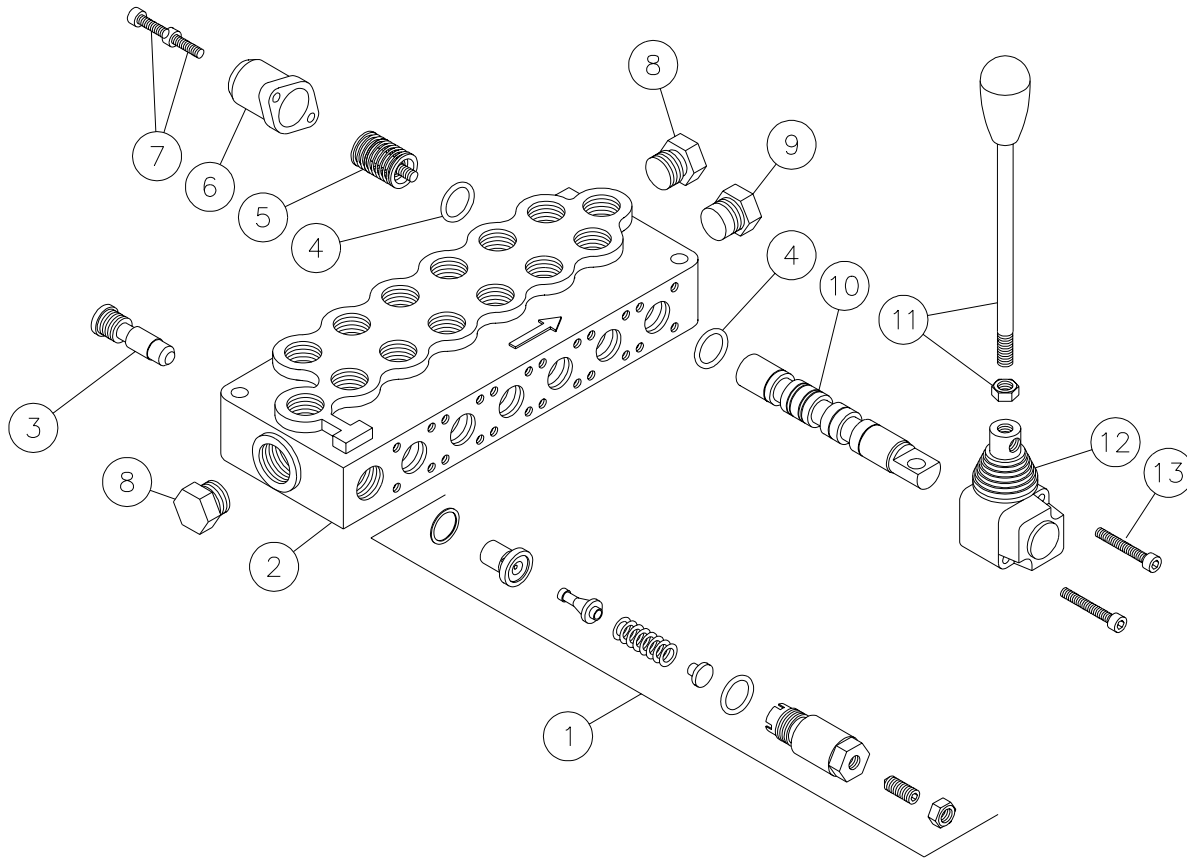

REF.	PART #	CODE #	DESCRIPTION	QTY
				32288
				32289
			Number of spool	4 1
1	32275	5KIT105413	Relief valve	1 1
2	32286	-----	Valve housing 4 spool	1 -
2	32287	-----	Valve housing 1 spool	- 1
3	32076	XKIT005000	Kit VR5	1 1
4	32077	4GUA115926	O-ring	8 2
5	32078	XV08105000	Spring	4 1
6	32079	3CAP210370	End cap	4 1
7	32080	4VIT605014	Screw M5 x 14	8 2
8	32081	3XTAP822150	Plug SAE8	2 2
9	32082	3XTAP623170	Plug (open center)	1 1
10	32085	3CU1210130	Valve spool (closed center)	4 -
10	32279	-----	Valve spool (open center)	- 1
11	32274	-----	Lever	4 1
12	32086	3XLEV105000	Lever endcap	4 1
13	32087	4VIT605035	Screw M5 x 35	8 2

8

HYDRAULIC DOUBLE PUMP #MHP22067/048K2SR

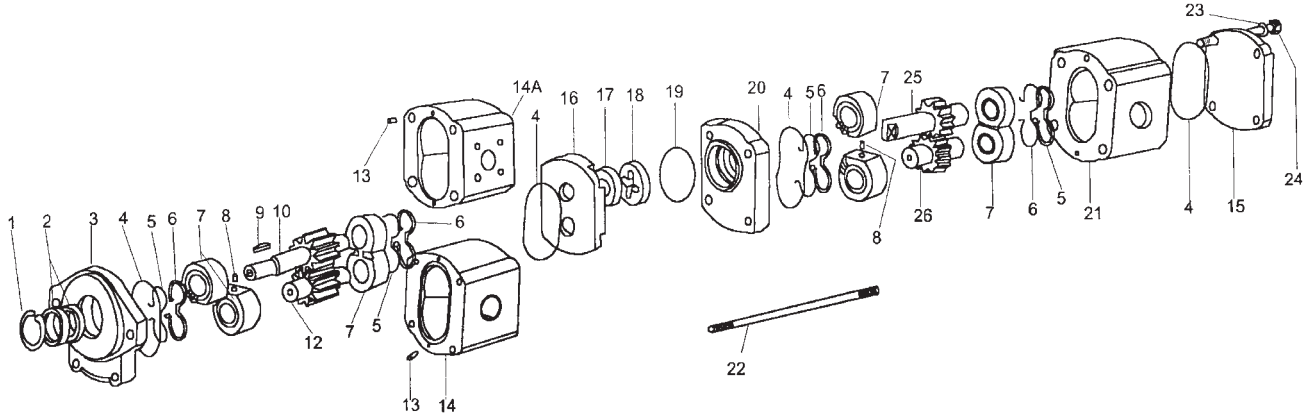

REF.	CODE #	DESCRIPTION	QTY
1	SN-2	Circlip	1
2	SS-2	Shaft seal	2
3	F2-2	Mounting flange	1
4	BO-2	Body o-ring	4
5	BS-2	Bush lobe seal	4
6	BR-2	Backing ring	4
7	BV-2	Bush (matching pair)	4
8	PB-2	Pin (bush)	4
9	KE-2	Square key	1
10	DSXX-048F	Drive shaft parallel (front)	1
11	WK-2	Woodruff key	1
12	DG2-048	Driven gear	1
13	PH-2	Pin (body)	1
14	H2-048	Body (sae port)	1
14a	H2-0485	Body (split flange)	0
15	C-2	End cover	1
16	MC-2	Middle cover	1
17	SC-2	Seal (middle cover)	1
18	DC-2	Coupling	1
19	FO-2	O-ring (middle flange)	1
20	MF-2	Middle flange	1
21	H2-067	Body	1
22	ST-067	Stud	2
23	LW-2	Washer	2
24	N-2	Nut	2
25	DS2-067R	Drive shaft (rear)	1
26	DG2-067	Driven gear (rear)	1

8

ENGINE ASSEMBLY WITH PUMP

170-03191

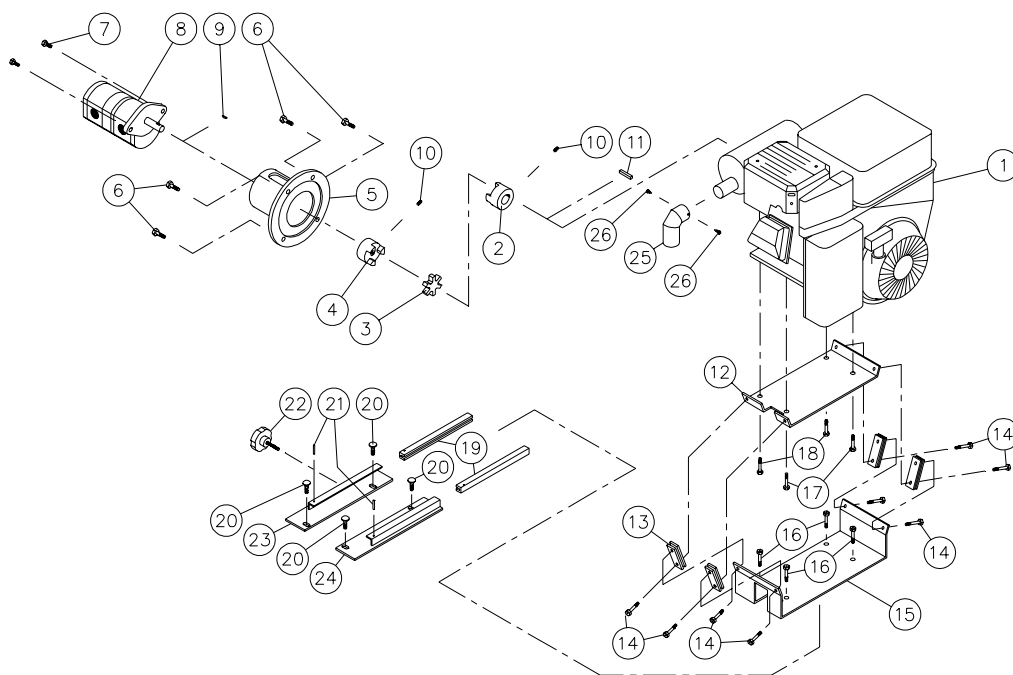

REF.	PART #	DESCRIPTION	QTY
1	32258	Engine HONDA 20HP with electric starter	1
2	32133	Flexible coupling 1" ø	1
3	32134	Flexible coupling	1
4	32259	Flexible coupling 5/8" ø	1
5	32260	Mounting flange	1
6	Std.	Bolt 3/8" NC x 1" lg + lock washer	4
7	Std.	Bolt 3/8" NC x 1 1/2" lg + lock washer	2
8	32290	Double pump (see reference p. 40)	1
9	Std.	Woodruff key 1/8"	1
10	Std.	Socket set screw 5/16" NC x 1/2"	2
11	Std.	Square key 1/4" x 1 1/2" lg	1
12	32194	Upper motor mounting plate	1
13	32195	Anti-vibration supports	8
14	Std.	Bolt 5/16" NC x 1" lg + nylon locknut & flat washer	8
15	32196	Lower motor mounting plate	1
16	Std.	Bolt 3/8" NC x 1" lg + nylon locknut	4
17	Std.	Bolt 3/8" NC x 1 3/4" lg + nylon locknut	2
18	Std.	Bolt 3/8" NC x 1 3/4" lg + nylon locknut & flat washer	2
19	190-00202	Sliding engine mount	2
20	Std.	Carriage bolt 3/8" NC x 1" lg + nylon locknut	4
21	Std.	Roll pin 1/8" x 1" lg	2
22	110-00591	Slide handle	1
23	110-18661	Left fixation for slide	1
24	110-18681	Right fixation for slide	1
25	110-06451	Exhaust deflector	1
26	Std.	Teck screw # 1--16 1/2" lg	2

8

HUB H2500

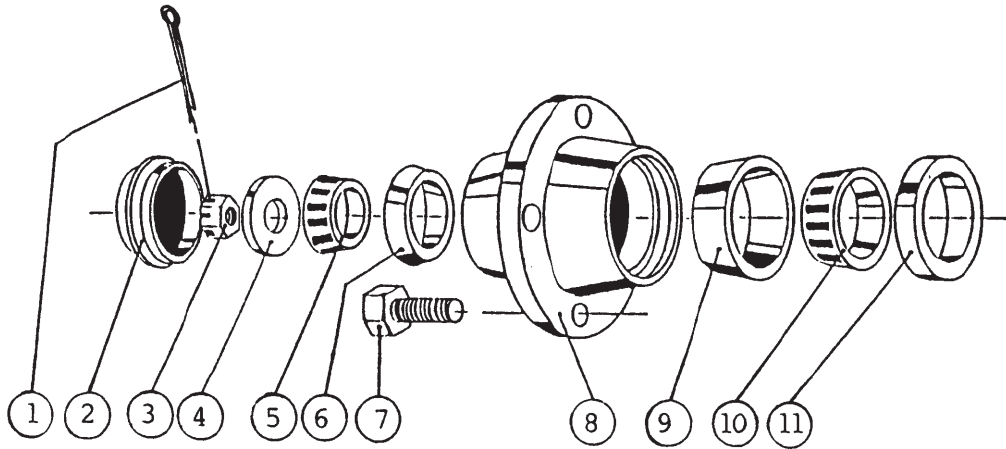

REF.	PART #	DESCRIPTION	QTY
1	Std.	Cotter pin 5/32" x 1 1/2"	1
2	53019	Dust cap D-1000 1.973" ø	1
3	51529	Castle nut 1" NF x 9/16" thick	1
4	Std.	Flat washer 1"	1
5	53058	Roller bearing Timken: cone no. L44649	1
6	53023	Roller bearing Timken: cup no. L44610	1
7	53024	Rim screw 1/2"	5
8	53059	Hub only H2500	1
9	51415	Roller bearing Timken: cup no. LM48510	1
10	51416	Roller bearing Timken: cone no. LM48548	1
11	51535	Oil seal no. CR17415	1

8

HYDRAULIC SYSTEM

170-02911

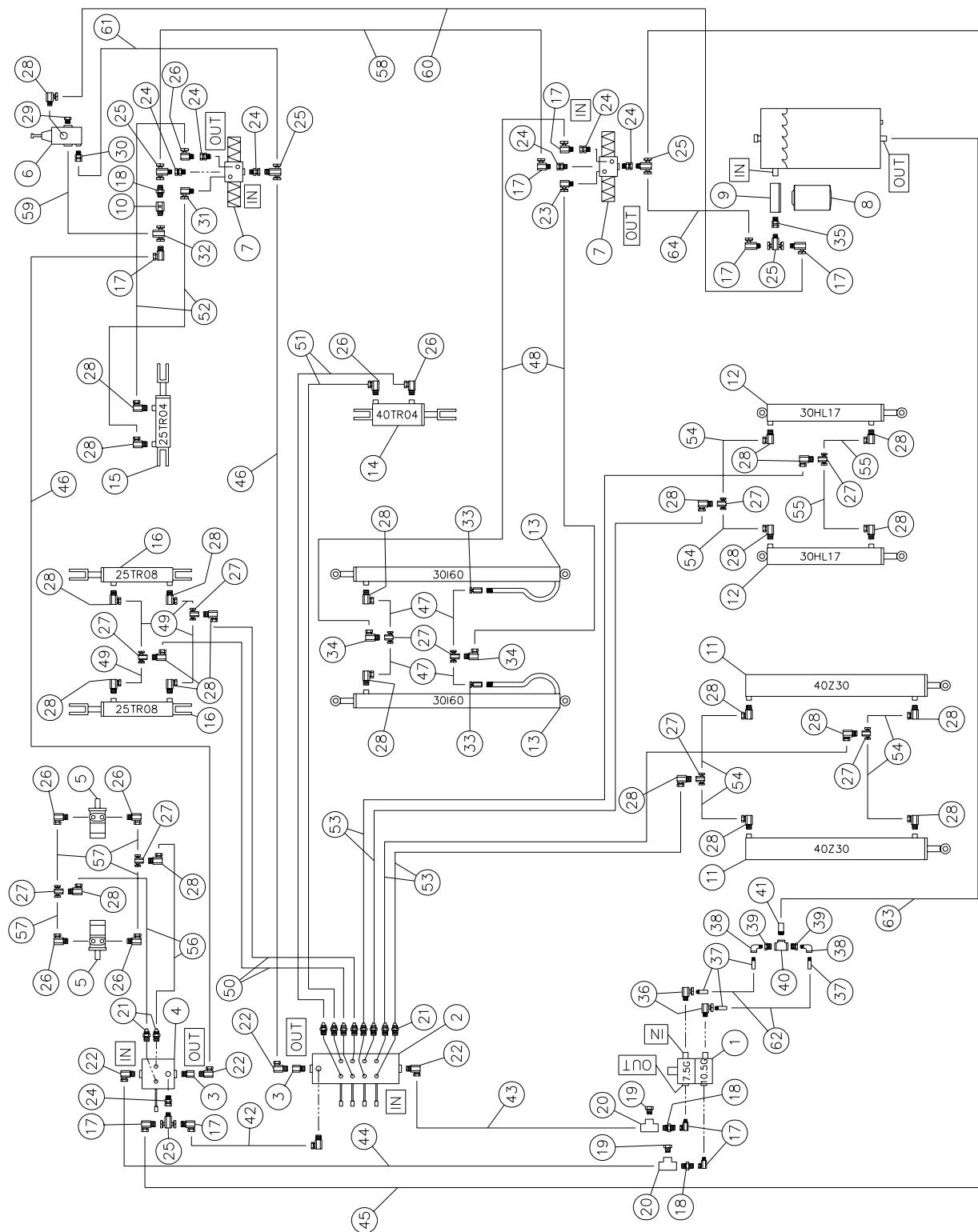

HYDRAULIC SYSTEM

REF.	PART #	DESCRIPTION	QTY
1	MHP-22067	Double hydraulic pump	1
2	048K2RS	4 spool control valve	1
3	Std.	Straight fitting (power beyond)	2
4	32239	1 spool control valve	1
5	DH315	Hydraulic motor DH315 + key (see p. 49)	2
6	32263	Unloading valve	1
7	18019	Solenoid valve	2
8	32007	Paper filter	1
9	32031	Hydraulic oil filter adapter	1
10	32262	Check valve 1/2" LT50-OW	1
11	40Z30	Cylinder 4" x 30" stroke	2
12	30HL17	Arch cylinder 3" x 17" stroke	2
13	30I60	Pusher cylinder 3" x 60" stroke	2
14	40TR04	Jack cylinder 4" x 4" stroke	1
15	25TR04	Steering cylinder 2 1/2" x 4" stroke	1
16	190-04711	Cylinder 2 1/2" x 8" stroke (rear wheel)	2
17	9405x8x8	Fitting 90 deg. swivel	9
18	C3069x8	Fitting straight	3
19	C3159x8	End cap	2
20	C3709x8	Fitting «T»	2
21	5315x8x8	Fitting straight	10
22	9515x10x8	Fitting 90 deg. swivel	4
23	9515x8x8	Fitting 90 deg. swivel	2
24	9315x8x8	Fitting straight	7
25	5855x8x8x8	Fitting «T»	5
26	9405x6x8	Fitting 90 deg. swivel	7
27	5856x6	Fitting «T»	10
28	9405x6x6	Fitting 90 deg. swivel	25
29	C3169x6	End cap	1
30	9205x6x4	Fitting straight	1
31	9515x8x6	Fitting 90 deg. swivel	1
32	5856x8x8x8	Fitting «T»	1
33	9255x6x6	Fitting straight	2
34	9405x8x6	Fitting 90 deg. swivel	2
35	C3109x12x8	Close nipple 3/4"-1/2"	1
36	9515x12x12	Fitting 90 deg. swivel	2
37	Std.	Hose fitting 3/4" 1 S225	4
38	C3409x12x12	Fitting 90 deg	2
39	C3109x16x12	Close nipple 1"-3/4"	2
40	C3709x16	Fitting «T»	1
41	Std.	Hose fitting 1" 1 S215	1
42	190-04761	Hose 1/2" x 9 1/4" lg + 2 fittings 8U108	1
43	190-04751	Hose 1/2" x 22" lg + 2 fittings 8U108	1
44	190-04791	Hose 1/2" x 29" lg + 2 fittings 8U108	1
45	190-04781	Hose 1/2" x 256" lg + 2 fittings 8U108	1
46	190-04911	Hose 1/2" x 264" lg + 2 fittings 8U108	2
47	190-04811	Hose 3/8" x 106" lg + 2 fittings 6U106	4
48	190-04801	Hose 1/2" x 116" lg + 2 fittings 8U108	2
49	190-04881	Hose 3/8" x 90" lg + 2 fittings 6U106	4
50	190-04871	Hose 3/8" x 134" lg + 1 fitting 6U106 + 1 fitting 22541x06x08	2

HYDRAULIC SYSTEM (cont'd)

REF.	PART #	DESCRIPTION	QTY
51	190-04891	Hose 3/8" x 172" lg + 1 fitting 6U106 + 1 fitting 22541x06x08	2
52	190-04921	Hose 3/8" x 204" lg + 2 fittings 6U106	2
53	190-04861	Hose 3/8" x 236" lg + 1 fittingr 6U106 + 1 fitting 22541x06x08	4
54	190-04841	Hose 3/8" x 86" lg + 2 fittings 6U106	6
55	190-04851	Hose 3/8" x 96" lg + 2 fittings 6U106	2
56	190-04821	Hose 3/8" x 180" lg + 1 fitting 6U106 + 1 fitting 22541x06x08	2
57	190-04831	Hose 3/8" x 59 1/2" lg + 2 fittings 6U106	2
58	190-04741	Hose 1/2" x 27" lg + 2 fittings 8U108	1
59	190-04901	Hose 3/8" x 9 1/4" lg + 1 fitting 6U106 + 1 fitting 6U108	1
60	190-04771	Hose 3/8" x 24" lg + 1 fitting 6U106 + 1 fitting 6U108	1
61	190-04961	Hose 3/8" x 18" lg + 1 fitting 6U106 + 1 fitting 6U108	1
62	190-04941	Low pressure hose 3/4" x 50"	2
63	190-04931	Low pressure hose 1" x 109"	1
64	190-05531	Hose 1/2" x 35" lg. + 2 fittings 8U108	1

ELECTRIC SYSTEM

170-00441

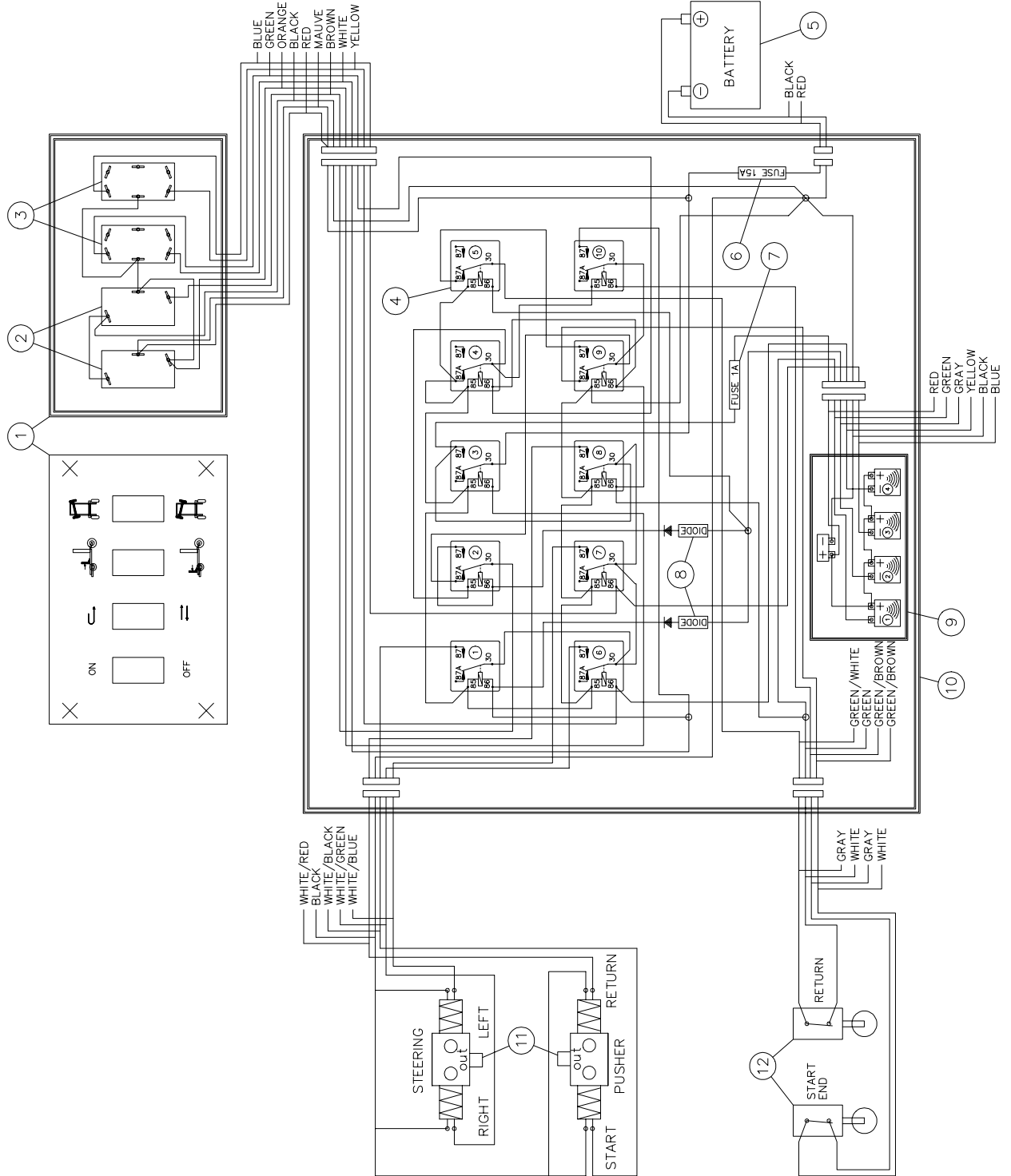

ELECTRIC SYSTEM (cont'd)

REF.	PART #	DESCRIPTION	QTY
1	32245	Manual control sealed box	1
2	32246	Switch on - off	2
3	32247	Switch (on) - off - (on)	2
4	18015	Relay	10
5	Std.	Battery 12V - 540A	1
6	32249	Fuse 15A	1
6	32248	Fuse holder	1
7	32250	Fuse 1A	1
7	32248	Fuse holder	1
8	32251	Diode	2
9	32252	Receiver 4 channel	1
10	32253	Sealed box	1
11	18019	Solenoid valve	2
12	32254	Limit switch	2
*NI	32255	Transmitter 4 channel	1
*NI	Std.	Battery for transmitter (Alkaline 12V no. A23)	1

ELECTRIC CIRCUIT

WORKING LIGHTS

170-03221

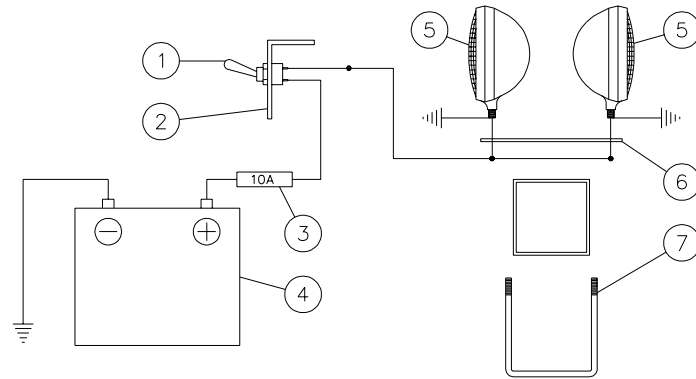

REF.	PART #	DESCRIPTION	QTY
1	32237	Switch ON-OFF	1
2	130-04481	Switch support	1
3	Std.	Fuse 10A	1
4	Std.	Battery 12V-540A	1
5	110-04771	Working lights	2
6	140-12131	Working lights retaining plate	1
7	150-04291	"U" bolt 3/8" NC x 7 1/16" x 8" + 2 nylon locknut	1

ROAD LIGHTS

170-03221

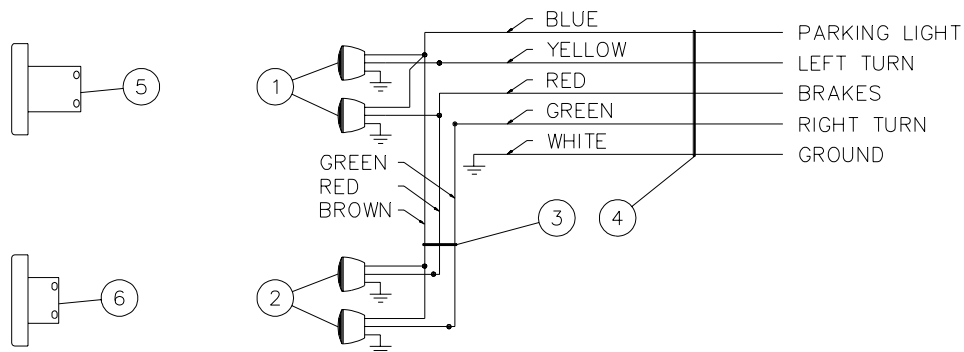

REF.	PART #	DESCRIPTION	QTY
1	32228	Left red flashers with license light	2
2	32229	Right red flashers	2
3	110-20471	3 conductors cable with terminal	1
4	110-20461	5 conductors cable with terminal	1
5	110-20451	Left support for flasher and license light	1
6	110-20441	Right support for flasher	1

8

HYDRAULIC MOTOR #DH 315

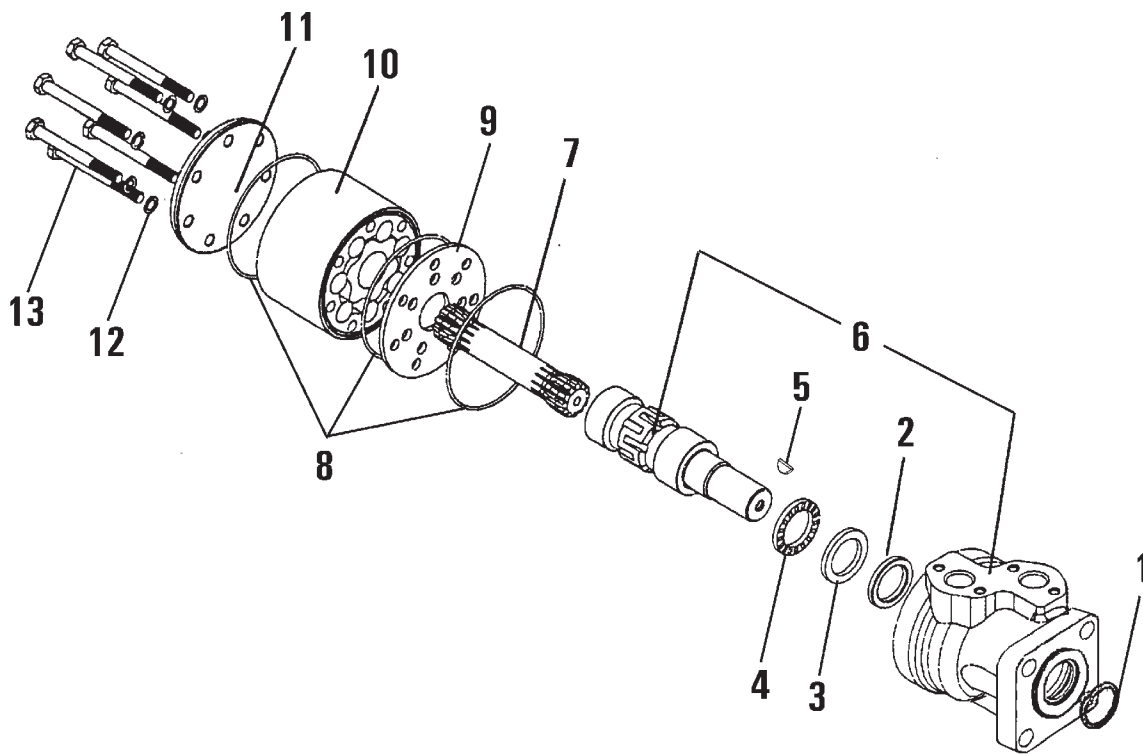







REF.	CODE #	DESCRIPTION	QTY
			DH 315
1	633B0370	Dust seal ring	1
2	633B0414	Shaft seal BAKDH ring	1
3	151-5708	Bearing race	1
4	151-5709	Axial needle bearing	1
5	682L9054	Woodruff key	1
6	-----	Housing and output shaft	not sold
7	151-2650	Cardan shaft	1
8	633B1173	O-ring	3
9	151-1713	Distributor plate	1
10	151-1186	Gear wheel set	1
11	151-2673	End cover	1
12	684X0076	Washer	6
13	681X0186	Screw M8 x 1.25mm Din 931 x 70mm lg	6
NI*	151-1286	Set of seals	1

*NI = NOT ILLUSTRATED





8

TORQUE CHART

TORQUE SPECIFICATION TABLE

Thread UNC and UNF		Grade 2 				Grade 5   				Grade 8*   			
Bolt size		Torque				Torque				Torque			
Inches	mm	Pound feet		Newton meters		Pound feet		Newton meters		Pound feet		Newton meters	
		min.	max.	min.	max.	min.	max.	min.	max.	min.	max.	min.	max.
1/4	6.35	5	6	6.8	8.13	9	11	12.2	14.9	12	15	16.3	30.3
5/16	7.94	10	12	13.6	16.3	17	20.5	23.1	27.8	24	29	32.5	39.3
3/8	9.53	20	23	27.1	31.2	35	42	47.5	57.0	45	54	61.0	73.2
7/16	11.11	30	35	40.7	47.4	54	64	73.2	86.8	70	84	94.9	113.9
1/2	12.70	45	52	61.0	70.5	80	96	108.5	130.2	110	132	149.2	179.0
9/16	14.29	65	75	88.1	101.6	110	132	149.2	179.0	160	192	217.0	260.4
5/8	15.88	95	105	128.7	142.3	150	180	203.4	244.1	220	264	298.3	358.0
3/4	19.05	150	185	203.3	250.7	270	324	366.1	439.3	380	456	515.3	618.3
7/8	22.23	160	200	216.8	271.0	400	480	542.4	650.9	600	720	813.6	976.3
1	25.40	250	300	338.8	406.5	580	696	786.5	943.8	900	1080	1220.4	1464.5
1 1/8	25.58	-	-	-	-	800	880	1084.8	1193.3	1280	1440	1735.7	1952.6
1 1/4	31.75	-	-	-	-	1120	1240	1518.7	1681.4	1820	2000	2467.9	2712.0
1 3/8	34.93	-	-	-	-	1460	1680	1979.8	2278.1	2380	2720	3227.3	3688.3
1 1/2	38.10	-	-	-	-	1940	2200	2630.6	2983.2	3160	3560	4285.0	4827.4

* Thick nuts must be used with grade 8 bolts.

Size of screw	Thread	Pitch (mm)	Grade 4T  				Grade 7T 				Grade 8T  			
			Torque				Torque				Torque			
			Pound feet		Newton meters		Pound feet		Newton meters		Pound feet		Newton meters	
		min.	max.	min.	max.	min.	max.	min.	max.	min.	max.	min.	max.	
M6	UNC	1.00	3.6	5.8	4.9	7.9	5.8	9.4	7.9	12.7	7.2	10	9.8	13.6
M8	UNC	1.25	7.2	14	9.8	19	17	22	23	29.8	20	26	27.1	35.2
M10	UNC	1.5	20	25	27.1	33.9	34	40	46.1	54.2	38	46	51.5	62.3
M12	UNC	1.75	28	34	37.9	46.1	51	59	69.1	79.9	57	66	77.2	89.4
M14	UNC	2.0	49	56	66.4	75.9	81	93	109.8	126	96	109	130.1	147.7
M16	UNC	2.0	67	77	90.8	104.3	116	130	157.2	176.2	129	145	174.8	196.5
M18	UNC	2.0	88	100	119.2	136	150	168	203.3	227.6	175	194	237.1	262.9
M20	UNC	2.5	108	130	146.3	176.2	186	205	252	277.8	213	249	288.6	337.4
M8	UNF	1.0	12	17	16.3	23	19	27	25.7	36.6	22	31	29.8	42
M10	UNF	1.25	20	29	27.1	39.3	35	47	47.4	63.7	40	52	54.2	70.5
M12	UNF	1.25	31	41	42	55.6	56	68	75.9	92.1	62	75	84	101.6
M14	UNF	1.5	52	64	70.5	86.7	90	106	122	143.6	107	124	145	168
M16	UNF	1.5	69	83	93.5	112.5	120	138	162.6	187	140	158	189.7	214.1
M18	UNF	1.5	100	117	136	158.5	177	199	239.8	269.6	202	231	273.7	313
M20	UNF	1.5	132	150	178.9	203.3	206	242	279.1	327.9	246	289	333.3	391.6

Use the above torques when special torque is not given.

NOTE: These values apply to fasteners as received from supplier, dry, or when lubricated with normal engine oil. They do not apply if extreme pressure lubricants are used.

WARRANTY

PRONOVOST warrants this product to the initial purchaser for the period of one year from the date of purchase against defects in materials and workmanship.

We will replace or repair defective parts free of charge if they are returned to our plant in St-Tite, Quebec, Canada.

Transportation charges are the responsibility of the customer. This warranty is not transferable.

Tires and gasoline engine are covered by the manufacturers of these items.

All PRONOVOST spare parts purchased are covered by a three (3) month warranty.

This warranty becomes void and nul if the equipment is modified, breaks down as result of an accident, if not operated according to manufacturer's recommendations, damaged by negligence or if maintenance has not been carried out as specified.

Our obligation is limited to the replacement or repair of the defective part. PRONOVOST accepts no responsibility for direct or indirect consequential damages of any kind.

Ce manuel est aussi disponible en français.
Veuillez téléphoner.



LES MACHINERIES PRONOVOST INC.
260, route 159,
Saint-Tite, Quebec, Canada, G0X 3H0
Tel.: (418) 365-7551, Fax: (418) 365-7954
www.pronovost.qc.ca