



**OPERATOR'S / PARTS
MANUAL**

SILATUBE

P-6200

**Models
P-6300**

P-6302



Copyright © Les Machineries Pronovost Inc., 2001

All rights reserved.
Printed in Canada.

TABLE OF CONTENTS

Section	Item	Page
1	Introduction	5
2	Safety	6
	General Safety	6
	Safety in Operation	6
	Safety with Maintenance	7
	Safety in Transport	7
	Safety in Storage	7
3	Decals	8
	Safety Decals	8
	Maintenance Decals	9
4	Start-up	10
	Basic Start-up Procedures	10
	Ground Preparation	11
	Adjustments of SilaTube	11
	Installation of Tube	13
	Operation	15
5	Maintenance	17
6	Storage	18
7	Plastic tubes to use	18
	Specifications	19
8	Parts List	20
	SilaTube P-6200 Assembly	20
	SilaTube P-6300 Assembly	23
	SilaTube P-6302 Assembly	26
	Detail of Arch Model P-6200	29
	Detail of Arch Model P-6300	30
	Detail of Arch Model P-6302	31
	Automatic System Detail	32
	Arch Cylinder P-6200	33
	Arch cylinder P-6300 & P-6302	34
	Pusher Cylinder # 20I72	35
	Cylinder 25TR04 & 25TR08	36
	6 Spool Control Valve # 32111	37
	1 Spool Control Valve # 32232	38
	Engine Assembly with Pump	39
	Hub H1000	40
	Hub H2500	41
	Hydraulic System	42
	Electric circuit	45
	Traction mechanism option	46
	1 Spool Control Valve # 640-10004 (SD4 open center)	47
	Hydraulic Motor # DH 315	48
9	Torque Chart	49
10	Warranty	50

INTRODUCTION

1

CONGRATULATIONS!

Thank you for choosing PRONOVOST. We are confident this equipment will meet your requirements in terms of quality, performance and reliability.

This manual was prepared to assist you in the safe operation of your new SilaTube. It contains important information which will help you achieve excellent returns with your tubing-machine for years to come.

Please read this manual completely before operating your SilaTube and keep it for future reference.

Before starting the machine, you or any other person who will be operating the SilaTube must familiarize yourself with the safety recommendations and the operating instructions. Please read carefully and be sure to understand and follow all recommendations and procedures.

In this manual, the right and left sides of the SilaTube are identified while standing at the discharge end of the machine and facing it.

If you require additional information on your SilaTube, please contact your PRONOVOST Dealer.

NOW take a moment to enter the model, serial number and the date of purchase of your SilaTube in the space provided.

When ordering parts from your Dealer, please refer to these numbers for a fast and efficient service. Use PRONOVOST parts for replacement.

The model and serial numbers are on the nameplate shown on Fig. 1.

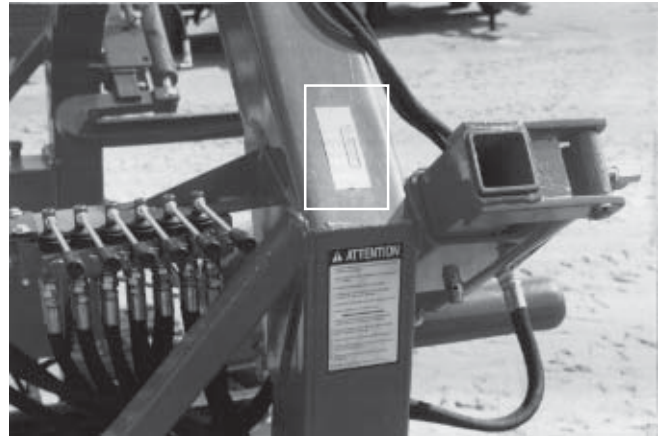

Figure 1

MODEL: _____ ✍

SERIAL NO.: _____ ✍

DATE OF PURCHASE: _____ ✍

SAFETY

GENERAL SAFETY

2

WHEN YOU SEE THIS SYMBOL



ATTENTION!

**BE ALERT
YOUR SAFETY IS INVOLVED**

This symbol «**SAFETY ALERT**» is used in this manual and on the safety decals on the SilaTube. It warns you of the possibility of danger. Carefully read, understand and follow all safety recommendations before operating the SilaTube.

- 1) Careful operation is the best assurance against accidents. Carefully read this manual and the motor manual and follow all recommendations before operating your SilaTube. It is the owner's responsibility to make sure that anyone who will operate the SilaTube will read these manuals before operating the equipment.
- 2) Never let a child operate the SilaTube.
- 3) Do not modify the SilaTube. Any non authorized modification may affect the efficiency and/or safety of the equipment.
- 4) Never operate the SilaTube with defective parts or if damaged in any way. Have it repaired before operating.
- 5) Make sure all fasteners are in place and properly secured or tightened. Refer to torque chart on page 49.
- 6) Avoid wearing loose fitting clothing when working with the SilaTube. These could get entangled in moving parts of the equipment and cause accidents.
- 7) Keep motor clean and exempt of dust and debris.
- 8) Before using the SilaTube, inspect the area where it is to be used and remove any object which could hamper normal operation or damage the plastic tube.
- 9) Hydraulic fluids under pressure can damage your skin. Do not use your hands to locate a leak.
- 10) Plastic bags are impervious to air. Keep them away from children to avoid suffocation.
- 11) When using a tractor equipped with a spear, be extremely careful. Always lower the spear to the ground before leaving your tractor.
- 12) Do not store, spill or use fuel near a flame, a hot engine or stove.

SAFETY IN OPERATION

STEP 1 APPLIES TO P-6300 AND P-6302

- 1) Position the engine outward before you start working with the SilaTube.
- 2) Be sure there are no obstructions around the equipment and that no one stands near the SilaTube when in operation.
- 3) Always refuel equipment when outside and away from flames or sparks.
- 4) Never run the engine inside. Do not operate the engine in a confined or non ventilated area. Carbon monoxide is a colorless, odorless and deadly gas.
- 5) Be careful when adjusting equipment with engine running.

SAFETY (cont'd)

- 6) Keep hands, feet, hair and clothing away from moving parts.
- 7) Should you need to step onto the SilaTube for whatever reasons, **ALWAYS** stop the motor since there is **RISK OF SERIOUS INJURY** if not stopped.
- 8) Do not refill fuel tank with engine running. Always let the engine cool off for a couple of minutes before refilling. Always use approved fuel containers.
- 9) Do not operate the engine if fuel is spilled. Move equipment away from the spill and avoid any spark until the complete evaporation of the fuel.
- 10) Do not smoke while refueling.
- 11) Do not operate engine with any accumulation of hay, leaves, dirt or any other combustible material near the exhaust muffler.
- 12) Avoid touching the hot muffler and cooling fins since they could cause burns to your skin.

SAFETY WITH MAINTENANCE

- 1) Perform the SilaTube maintenance according to the recommendations contained in this manual.
- 2) Stop engine and relieve all hydraulic pressures before doing inspection, maintenance or repairs.
- 3) Do not check spark with spark plug or wire removed. Use the appropriate testing equipment.
- 4) Regularly check fuel lines and fittings for leaks. Replace if necessary.

SAFETY IN TRANSPORT

- 1) Be sure to engage the two safety locks (A Figure 2) provided for the rear wheels hydraulic cylinders (B Figure 2).

STEP 2 APPLIES TO P-6300 AND P-6302

- 2) Slide the engine to the inward position (transport position) in order not to exceed the legal width on the road.
- 3) Check local regulations for the transport of your SilaTube on the road.
- 4) Be alert when pulling the SilaTube on the road. Do not allow anyone to stand on it while in motion.
- 5) The road speed should be such as to maintain full control over steering and braking.
- 6) Be careful while backing up.

2

SAFETY IN STORAGE

- 1) Let engine cool and drain fuel from tank.
- 2) Do not let children play in the area where the SilaTube is stored.
- 3) Do not leave a tube installed on the SilaTube.
- 4) Do not let the SilaTube stand on the tires. Lower it to the ground or on wooden blocks. **THIS WILL AVOID ANY ACCIDENTAL CRUSHING OF ANIMALS OR ANYONE WHO COULD CRAWL UNDER THE EQUIPMENT.**

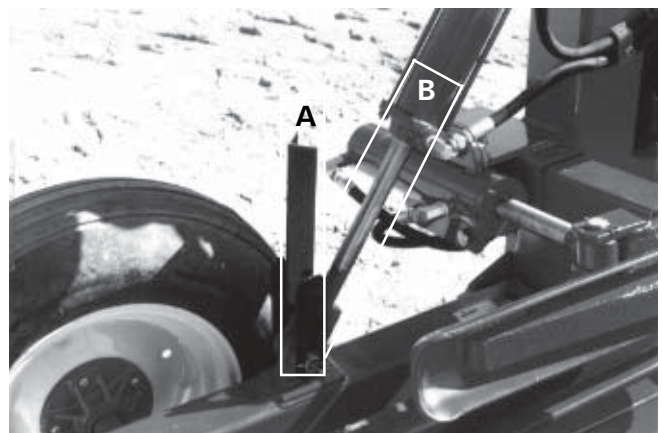

Figure 2

DECALS

SAFETY DECALS

The safety decals are affixed wherever special safety precautions are indicated. Locate them on the machine and read them carefully. If a decal is damaged, lost or illegible, install a new one. Each decal is identified with a letter and part number. The following photos indicate where each one must be installed.

3

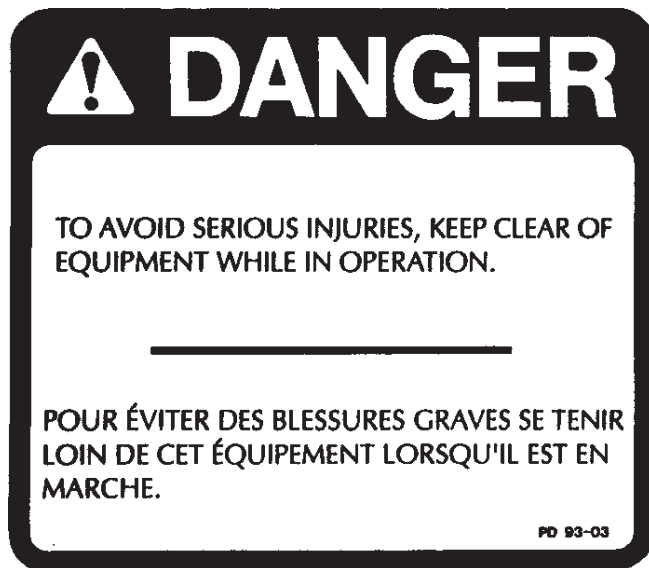

Figure 3
Decal A

Part no.: A101

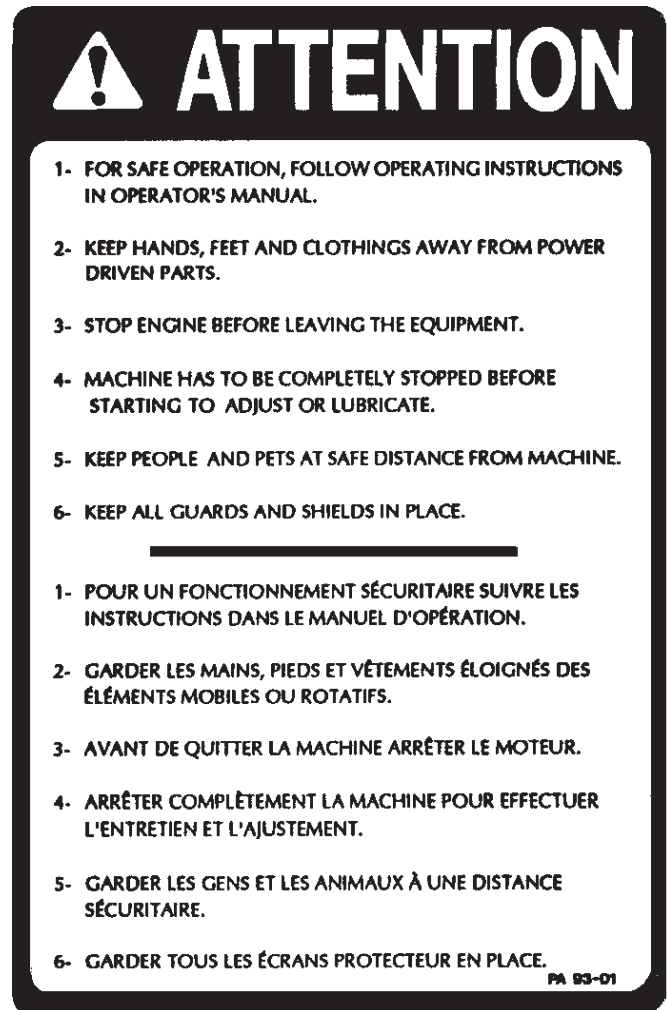

Figure 5
Decal B

Part no.: A102



Figure 4



Figure 6

DECALS (cont'd)



Figure 7
Decal C

Part no.: A103



Figure 8

MAINTENANCE DECALS

The maintenance decals indicate the points requiring lubrication. Refer to the maintenance section for more details.



Figure 9

Part no.: A104

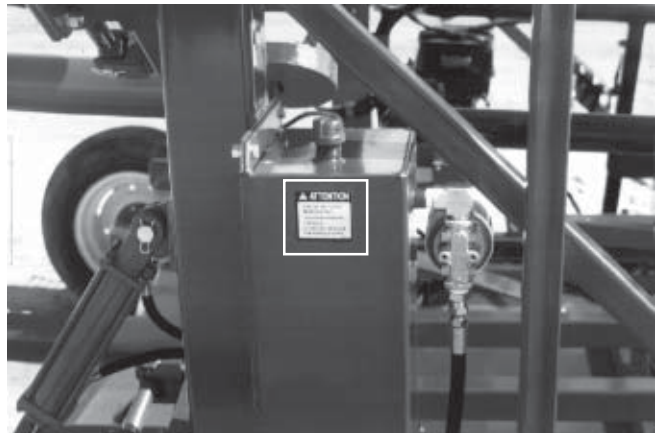

Figure 10



Figure 11

Part no.: A 106

STARTING-UP

4

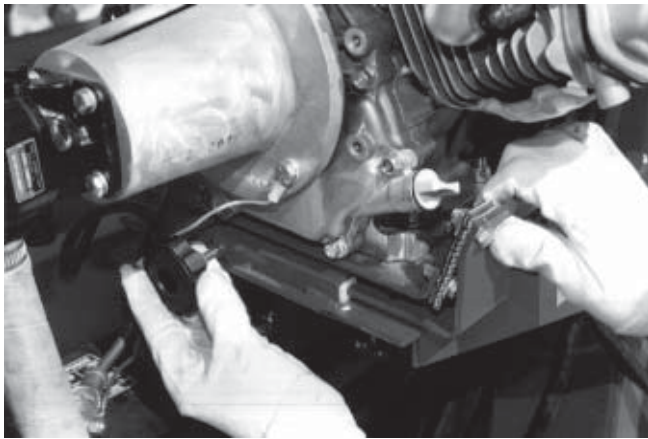

Figure 12

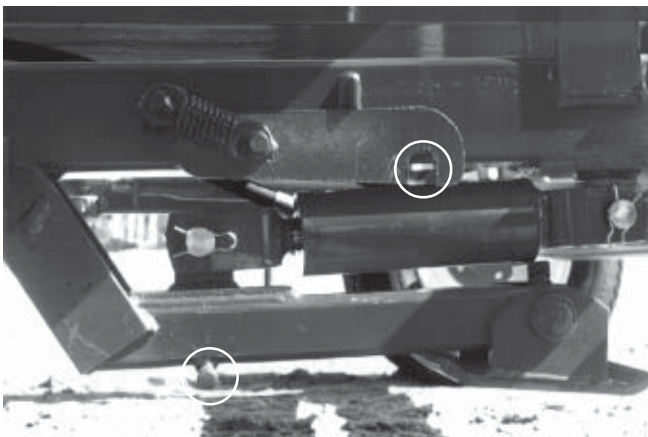

Figure 13

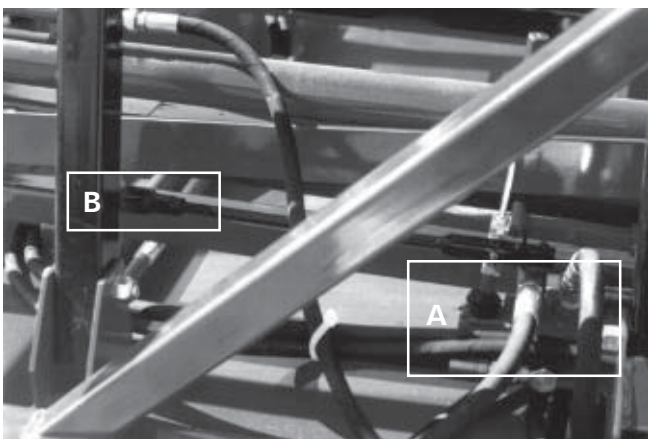

Figure 14

BASIC START-UP PROCEDURES

STEP 1 APPLIES TO P-6300 AND P-6302

- 1) The SilaTube engine is mounted on a sliding base so it can be easily placed in transport position in order not to exceed the legal width on the road. Do not forget to re-position the engine outward before starting. (Fig. 12)
- 2) Do not forget to unlock the hydraulic jack before lowering and always lock it when in the retracted position. (Fig. 13)
- 3) Verify for adequate tightness of all fastening devices. Refer to torque chart on page 49.
- 4) Lubricate all points and guide mechanisms requiring grease, with a high quality lithium base grease containing molybdenum disulfide (MoS_2) such as «Esso Unirex EP1 Moly», «DARINA XL-Multi Season Moly, Grade #1» from Shell or equivalent.
- 5) Check oil level in hydraulic reservoir. Use good quality tractor transmission and hydraulic system oil such as «Trans Hydraulic Duratran» from Petro Canada, «DONAX TD» from Shell or equivalent.
- 6) Check tire pressure and adjust according to recommendation indicated on the tires.
- 7) Check engine oil level.
- 8) Check the operation of all hydraulic cylinders.
- 9) Check the operation of the bale pusher mechanism. It must operate freely and return to its starting position automatically. Should the valve (A Fig. 14) not engage positively, adjust the rod end clevis (B Fig. 14).

STARTING-UP (cont'd)

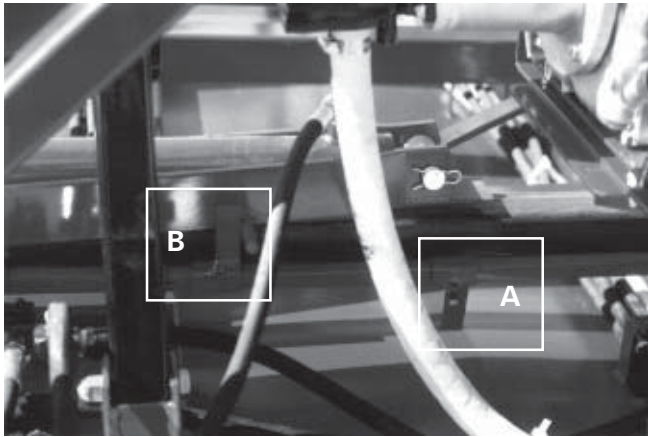

Figure 15



Figure 16



Figure 17

- 10) Check and if necessary, adjust the length of travel of the pusher by changing the position of lug "A" figure 15. To prevent bottoming of the piston, always keep $\frac{1}{2}$ " to $\frac{3}{4}$ " of travel at either end of the cylinders. The retracted position is adjusted in the same manner with lug "B" figure 15.
- 11) Check the surface of the stretcher arms for smoothness. Any mark or protrusion could cause tears to the tube.

GROUND PREPARATION

- 1) Choose a dry and well drained area.
- 2) Level and clean up site where the tubes will be used.
- 3) If possible, provide a sand bed of 2" to 3" (5-8 cm.) thick. This will help reduce damage from rodents.

ADJUSTMENT OF SILATUBE

STEP 1 APPLIES TO P-6300 AND P-6302

- 1) Position the six (6) stretcher hydraulic cylinder assemblies according to the size of tube used. Use the inside holes for 4 ft. tubes, 48" to 56" (1.22 to 1.42 m) (Fig.16). Use the outside holes for 5 ft. tubes, 56" to 66" (1.42 to 1.68 m) (Fig.17).
- 2) Locate the rear end of the SilaTube approximately 5' (1.5m) away from the point where you want to position the end of the tube. This will compensate if there is some slippage of the first couple of bales until there is enough ground friction to push the SilaTube forward.

4

STARTING-UP (cont'd)

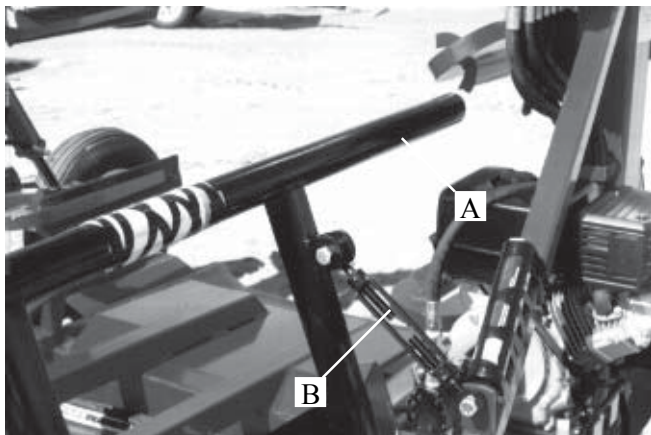

4 Figure 18



Figure 19



Figure 20

- 3) Adjust guides (A Fig.18) according to the width of the bales. Use turnbuckles provided (B Fig.18).
- 4) Adjust tongue to its most inward position. If there is a risk of interference with the front of the tractor or with uneven ground, it is recommended to remove it. (Fig. 19)
- 5) Adjust rear wheels in order to have a minimum amount of ground friction with the rear end of the SilaTube (Fig. 20) while keeping it in contact with the ground.
- 6) For maximum operating speed, you may set the engine to full throttle, although it is preferable to run it a speed closer to your rate of bale supply to machine. This will result in a more economical operation.

STARTING-UP (cont'd)

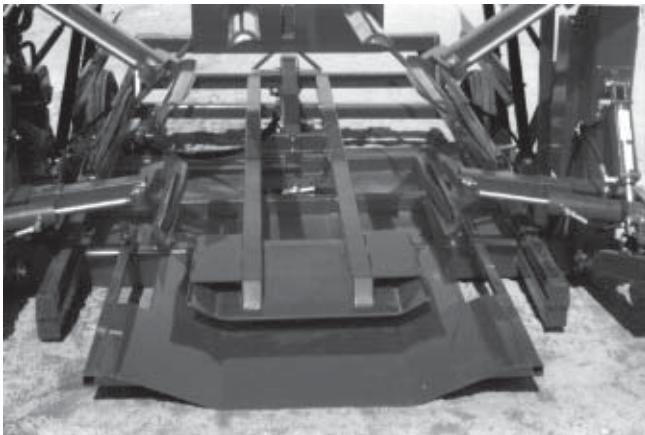

Figure 21



Figure 22



Figure 23

INSTALLATION OF THE TUBE

To facilitate this procedure, adhere to the following sequence:

- 1) Start engine.
- 2) Close the stretcher arms to the most inward position and pull out the tube support plate. (Fig. 21)
- 3) Install tube on the stretcher arms. Place it so that the tube name is facing outside when it unfolds. Slide it carefully **to the bottom** of the stretcher arms and between the two bottom plates, being careful to remove all wrinkles, since they could cause some tearing of the tube. (Fig. 22)
- 4) At this stage, apply a **SLIGHT AMOUNT OF TENSION** to the tube.
P-6200: Open each pair of stretcher arms until the end of the internal square tubing reaches the pilot hole of the outer tube. (Fig. 23)
P-6300 & P-6302: Open each pair of stretcher arms until the pilot hole in the square tubing reaches the lower end of the guide tube. (Fig. 24)
- 5) Do not forget to fully retract the tube support plate until it is locked in place. (Fig. 25)

4



Figure 24

STARTING-UP (cont'd)

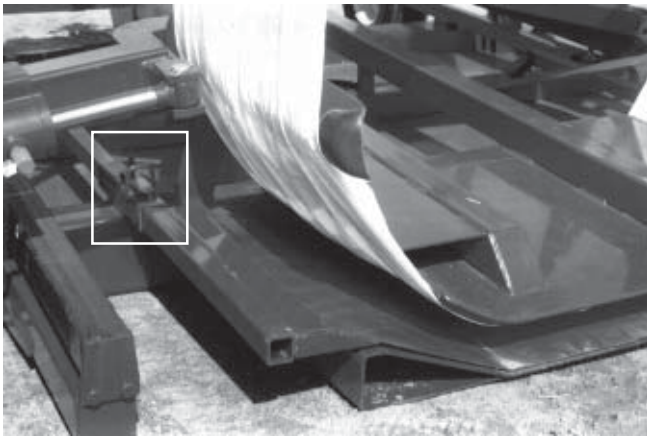

4 Figure 25

- 6) Again check the tube position (Fig. 26) and eliminate any wrinkles. Next, cut off all ties (Fig. 27).
- 7) Now it's time to close the end of the tube. Pull out the outer ply for approximately 36" (91 cm) and tie properly. (Fig. 28 and Fig. 29)
- 8) **STRETCH THE TUBE ONLY WHEN READY TO OPERATE.** It may lose some of its memory if kept stretched for a too long period of time. If you must stop loading bales for a while, **BRING THE TUBE DOWN TO A MODERATE TENSION.**



Figure 26



Figure 28



Figure 27



Figure 29

STARTING-UP (cont'd)



Figure 30

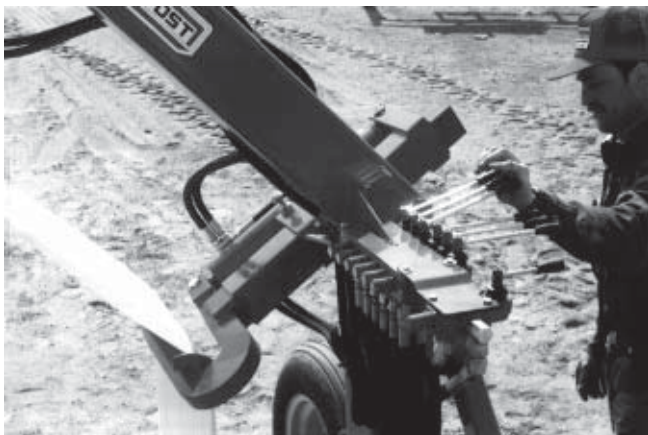

Figure 31



Figure 32

OPERATION

- 1) Before loading the first bale, disengage the pusher control valve by flipping the safety lock outward. (Fig. 30) Load the first bale on the machine, operate the control valve manually until the bale approaches the arms and stop it there.
- 2) Stretch the tube by operating the three valves **SIMULTANEOUSLY** (Fig. 31) to obtain a **CLEARANCE OF APPROXIMATELY 2" to 3"** between the bale and the tube (Fig. 32). Readjust stretcher arms individually if necessary.
- 3) At this point, check again the rear wheels adjustment for **minimum** ground friction (step 5, page 12) before engaging the bale pusher valve.
- 4) Reset the safety lock by pushing it fully inward. Engage the valve manually to complete the cycle automatically.
- 5) It is recommended to use a spear (single or double) on your loader to drop the bales onto the SilaTube.
- 6) Once the bale is dropped, back up immediately to make room for the SilaTube's forward movement.
- 7) After the first 3 or 4 bales, lower the rear of the SilaTube to increase ground friction. This will ensure that the bales will be real tight against each other in the tube.
- 8) You can steer SilaTube with a lever on the control valve in order to make a straight row.
- 9) Towards the end of the tube, keep at least 36" (91 cm) of plastic, in order to allow for proper closure of the tube.

4

STARTING-UP (cont'd)

4



Figure 33



Figure 34



Figure 35

- 10) To push the last bale into the tube, install the pusher extension supplied with the SilaTube. (Fig. 33)
- 11) Manually engage the pusher valve to initiate the last bale cycle. (Fig. 34)
- 12) Remove the pusher extension and store it in it's receptacle on the right hand side of the SilaTube. (Fig. 35)
- 13) Close up end of tube as previously described. (Fig. 28 & Fig. 29)
- 14) Regularly inspect the tubes. If torn or punctured, repair openings with proper means.

MAINTENANCE

- 1) Refer to the manufacturer's instructions for the engine.
- 2) Use a high quality lithium base grease containing molybdenum disulfide (MoS_2) such as «Esso Unirex EP1 Moly», «DARINA XL-Multi Season Moly, Grade #1» from Shell or equivalent.
- 3) Wipe off all grease fittings with a clean cloth before adding grease in order to avoid injecting dirt or sand.
- 4) Repair or replace damaged grease fittings.
- 5) Lubricate long pusher guides every 8 hours of operation.
- 6) Lubricate stretcher arms guides every 20 hours of operation.
- 7) Lubricate all grease fittings every 20 hours of operation.
- 8) Open, clean and lubricate wheel bearings once a year.
- 9) Check oil level in hydraulic reservoir every 20 hours of operation. If necessary add good quality trans hydraulic oil such as «Trans Hydraulic Duratran» from Petro-Canada, «DONAX TD» from Shell or equivalent.
- 10) Change oil filter after the first 50 hours of operation and then every 250 hours. Use replacement filter no. K-22001, PRONOVOST part No. 32007.
- 11) Check all nuts and bolts once a year. If necessary use torque chart on page 49.
- 12) Check all bolts on wheels after first 5 hours of operation and then every 50 hours.
- 13) Check tire pressure every 50 hours. Adjust according to manufacturer's recommendation indicated on the tires.

STORAGE

- 1) Store the SilaTube in a cool, dry place.
- 2) Lower the SilaTube frame on wooden blocks.
- 3) Keep tires off the ground and cover them if left exposed to the sun.
- 4) Keep all piston rods in the retracted position. This will assure better protection against the elements.
- 5) Clean your SilaTube.
- 6) Touch-up or repaint if necessary.
- 7) Lubricate all points before storage.
- 8) Drain all fuel from tank and follow engine manufacturer's storage recommendations.

6

7

PLASTIC TUBES TO USE

PLASTIC TUBES TO USE ACCORDING TO BALES DIMENSIONS

Use stretchable and recyclable plastic tube. Thickness 0.004 mil..

150' (45.7 m) long (35 four foot (1.2 m) bales) or 220' (67.1 m) long (53 four foot (1.2 m) bales).

P-6200, P-6300 & P-6302	Round bales	For bales 44" to 52" (1.12 to 1.32m) diameter	69" (1.75 m) lay flat <small>(Use with adaptor)</small>
P-6200, P-6300 & P-6302	Round bales	For bales 48" to 56" (1.22 to 1.42 m) diameter	73½" (1.87 m) lay flat
P-6300, P-6302	Round bales	For bales 52" to 61" (1.32 to 1.55 m) diameter	82" (2.08 m) lay flat
P-6300, P-6302	Round bales	For bales 56" to 66" (1.42 to 1.68 m) diameter	86" (2.18 m) lay flat
Square bales	Bales height + Bales width = Half-perimeter		
P-6302	Square bales	For half-perimeter 84" to 100" (2.13 to 2.54 m)	82" (2.08 m) lay flat

SPECIFICATIONS

SilaTube model	P-6200	P-6300	P-6302
Overall length at work	153" (3.89 m)	153" (3.89 m)	153" (3.89 m)
Overall length in transport	176" (4.47 m)	176" (4.47 m)	176" (4.47 m)
Overall width at work	102" (2.59 m)	112" (2.85 m)	112" (2.85 m)
Overall width in transport	102" (2.59 m)	100" (254 m)	100" (254 m)
Overall height in transport	92" (2.34 m)	93" (2.36 m)	93" (2.36 m)
Bales diameter	48" to 56" (1.22 à 1.42 m)	48" to 66" (1.22 à 1.68 m)	48" to 66" (1.22 à 1.68 m)
Adaptor for stretchers for bales of smaller diameter	44" to 52" (1.12 à 1.32 m) Option (P-6210)	44" to 52" (1.12 à 1.32 m) Option (P-6310)	44" to 52" (1.12 à 1.32 m) Option (P-6310)
Square bales height	-----	-----	36" (914 mm)
Square bale width	-----	-----	60" (1524 mm)
Engine	HONDA 9 HP	HONDA 9 HP	HONDA 9 HP
Manual starting	Standard	Standard	Standard
Electric starting	Option	Option	Option
Two stages hydraulic pump	3 gal at 2800 psi 11 gal at 1400 psi	3 gal at 2800 psi 11 gal at 1400 psi	3 gal at 2800 psi 11 gal at 1400 psi
6 spool control valve	Adjusted at 2800 psi	Adjusted at 2800 psi	Adjusted at 2800 psi
1 spool control valve	Adjusted at 1800 psi	Adjusted at 1800 psi	Adjusted at 1800 psi
Front hub (cap. - bolts)	1000 lbs (450 kg) - 4	2500 lbs (1136 kg) - 5	2500 lbs (1136 kg) - 5
Rear hub (cap. - bolts)	2500 lbs (1136 kg) - 5	2500 lbs (1136 kg) - 5	2500 lbs (1136 kg) - 5
Front rim (dim. - bolts)	10" x 6" - 4	10" x 6" - 5	10" x 6" - 5
Rear rim (dim. - bolts)	15" x 5" - 5	15" x 6" - 5	15" x 5" - 5
Front tires (with tube)	20.5" x 8" x 10" - 4 plys	20.5" x 8" x 10" - 4 plys	20.5" x 8" x 10" - 4 plys
Rear tires (with tube)	6.7" x 15" - 6 plys	7.6" x 15" - 8 plys	7.6" x 15" - 8 plys
Performance	70 to 100 bales per hour	70 to 100 bales per hour	70 to 100 bales per hour
Oil tank capacity	5.75 gal US (4.75 gal imp) (21.75 liters)	5.75 gal US (4.75 gal imp) (21.75 liters)	5.75 gal US (4.75 gal imp) (21.75 liters)
Hyd. steering adjustment	Standard	Standard	Standard
Working lights	Option (P-6245)	Option (P-6245)	Option (P-6245)
Road lights	Option (P-6240)	Option (P-6240)	Option (P-6240)
Motorized moving kit	Option (P-6225)	Option (P-6325)	Option (P-6325)
Hitch weight (app.)	1360 lbs (612 kg)	1410 lbs (635 kg)	1524 lbs (693 kg)
Total weight (app.)	3675 lbs (1655 kg)	3900 lbs (1756 kg)	4215 lbs (1916 kg)

Design and specifications subject to change without notice.

SILATUBE P-6200 ASSEMBLY

170-02171

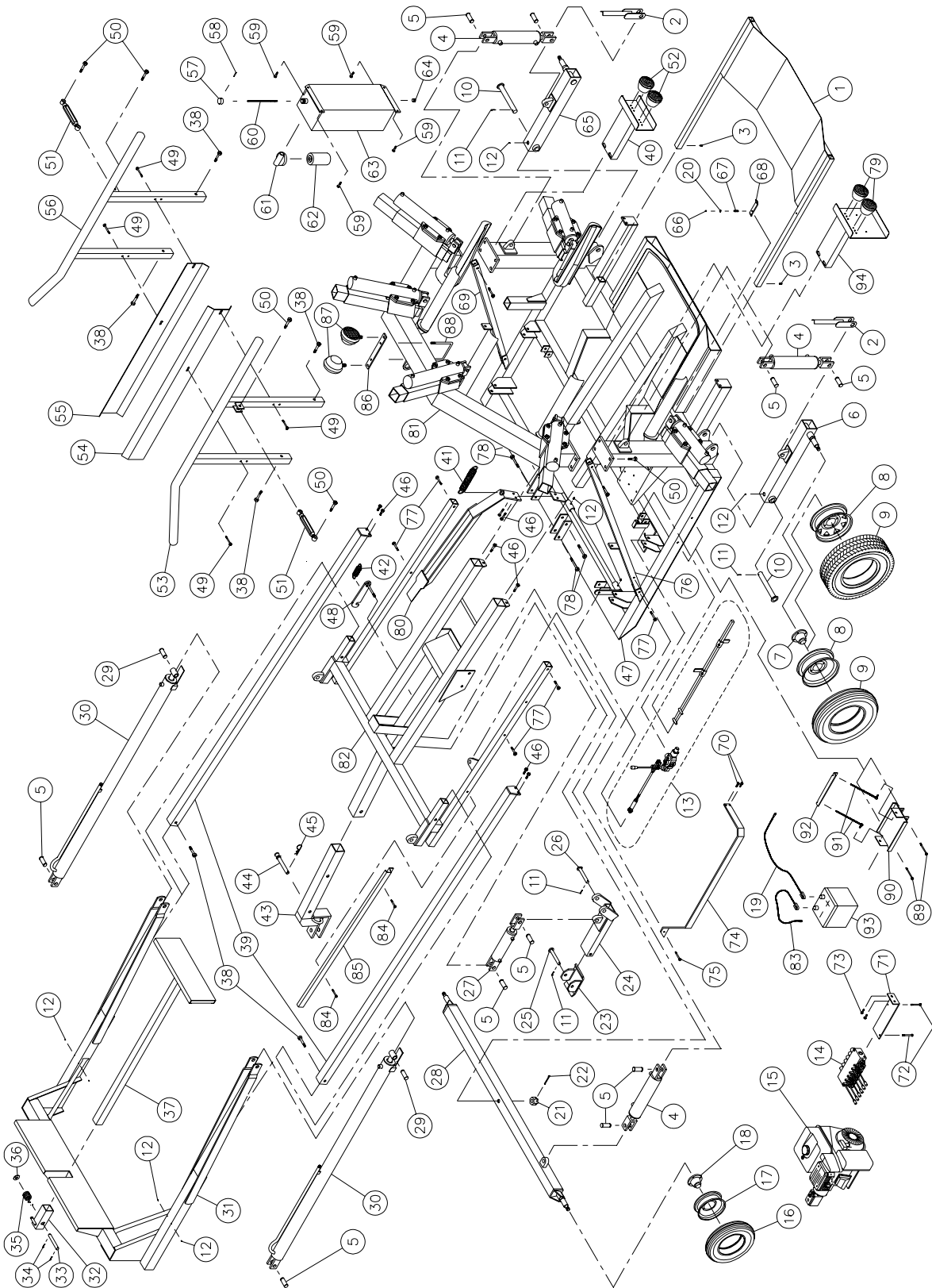

SILATUBE P-6200 ASSEMBLY (cont'd)

REF.	PART #	DESCRIPTION	QTY
1	32107	Tube support plate	1
2	32108	Safety locking mechanism for rear wheels	2
3	Std.	Bolt 1/4" NC x 3/4" lg + nylon locknut	2
4	25TR08	Cylinder 2.5" x 8" standard (see details p. 36)	3
5	D-60051	Pin 1" x 3" lg	10
6	110-03441	Left rear axle	1
7	32218	Hub H-2500 (see details p. 41)	2
8	R-1555	Rim 15 x 5 x 5	2
8	R-1575RT	Rim 15 x 7 x 5 (2)	opt.
9	PN-6.7015	Tire 6.7 x 15 - 6 ply + tube 6.70 x 15 TR-15	2
9	PN-7.0015RT	Tire 7.00 x 15 (2)	opt.
10	32034	Pin for rear axle (P-6200)	2
11	Std.	Cotter pin 5/32" x 1 3/4" lg	4
12	Std.	Grease fitting 1/4"-28 straight	8
13	- - -	Automatic system detail (see details p. 32)	1
14	32111	6 spool control valve (see details p. 37)	1
15	- - -	HONDA 9 HP engine assembled with pump (see details p. 39)	1
15	- - -	HONDA 9 HP engine with electric starter assembled with pump (see details p. 39)	opt.
16	PN-20.58	Tire 20.5 x 8 x 10 - 4 ply	2
17	R-1064	Rim 10 x 6 x 4	2
18	53015	Hub H-1000 (see details p. 40)	2
19	51606	Battery cable 4G x 30" lg	opt.
20	Std.	Flat washer 1/4" d.i. x 9/16" d.e.	1
21	32114	Castle nut 1" - 8	1
22	Std.	Cotter pin 5/32" x 2"	1
23	32115	Base, hydraulic jack	1
24	32116	Body, hydraulic jack	1
25	32117	Pin for hydraulic jack base	1
26	32118	Pin for hydraulic jack body	1
27	25TR04	Cylinder 2.5 x 4" standard (see details p. 36)	1
28	32119	Front axle assembly (P-6200)	1
29	32019	Pin 1"	2
30	20172	Cylinder 2" x 72" lg (see details p. 35)	2
31	32205	P-6200 bale ram frame	1
32	32121	Ram extension support	1
33	32122	Pin	1
34	Std.	Cotter pin 3/16" x 1 3/4" lg	2
35	32123	Ram extension support spring	1
36	Std.	Washer 1"	1
37	32124	Ram extension	1
38	Std.	Bolt 5/8" NC x 3 1/2" lg + nylon locknut	6
39	32022	Ram guide	2
40	110-03501	Right support for flasher	opt.
41	1201	Tension spring 1/4" x 1 13/16" x 10 1/2" lg	1
42	32008	Tension spring 1 1/4" x 3 1/2" lg	1
43	32199	Drawbar	1
44	32024	Drawbar pin	1
45	Std.	Hitch pin clip 5/32"	1
46	Std.	Bolt 1/2" NC x 1 1/2" lg + nylon locknut	8
47	120-00641	P-6200 main frame	1
48	32128	Locking mechanism for jack	1
49	Std.	Bolt 7/16" NC x 3" lg + nylon locknut + flat washer	4
50	Std.	Bolt 5/8" NC x 2 1/2" lg + nylon locknut	12
51	32014	Turnbuckle 10"	2
52	32229	2 Right flashers	opt.
53	32025	Left bale guide (P-6200)	1

SILATUBE P-6200 ASSEMBLY (cont'd)

REF.	PART #	DESCRIPTION	QTY
54	130-04281	Left protector	1
55	130-04271	Right protector	1
56	32028	Right bale guide (P-6200)	1
57	32029	Oil reservoir cap	1
58	Std.	Roll pin 5/32" x 1 3/4"	1
59	Std.	Bolt 7/16" NC x 1" + nylon locknut	4
60	32030	Dip stick	1
61	32031	Hydraulic oil filter adaptor FSP107-1E DNN	1
62	32007	Paper filter K-22001	1
63	32033	Oil reservoir	1
64	32032	Drain plug 1/2"	1
65	110-03451	Right rear axle	1
66	Std.	Nylon locknut 1/4" NC	1
67	32130	Compression spring 13/32" x 1 1/2" lg	1
68	32131	Locking device for support plate	1
69	160-02081	Arch brace (right side)	1
70	Std.	Bolt 3/8" NC x 1 1/4" lg + nylon locknut	2
71	110-11651	Valve support	1
72	Std.	Bolt 5/16" NC x 2 1/2" lg + nylon locknut	2
73	Std.	Bolt 7/16" NC x 3/4" lg + lockwasher & flat washer	2
74	32208	Guard	1
75	Std.	Bolt 3/8" NC x 3" lg + nylon locknut	1
76	160-02221	Arch brace (left side)	1
77	Std.	Bolt 1/2" NC x 3 1/2" lg + nylon locknut	8
78	Std.	Bolt 5/8" NC x 4 1/2" lg + nylon locknut	4
79	32228	2 Left flashers with license light	opt.
80	32213	Trigger	1
81	120-00611	Arch frame	1
82	120-00631	Support structure for ram guide	1
83	51607	Battery cable 4G x 10" lg	opt.
84	Std.	Bolt 3/8" NC x 2 3/4" lg + nylon locknut & flat washer	2
85	32207	Guard	1
86	140-02901	Working lights retaining plate	opt.
87	110-04771	2 Working lights	opt.
88	150-00971	"U" bolt 3/8" NC + 2 nylon locknut	opt.
89	Std.	2 Bolts 5/16" NC x 4" lg + nylon locknut	opt.
90	110-04831	Battery support	opt.
91	110-11511	2 Threaded rods for battery hold down + nylon locknut 3/8" NC and 7/16" NC	opt.
92	130-05751	Battery hold down	opt.
93	32283	Battery 12V-540A	opt.
94	110-03511	Left support for flasher	opt.

SILATUBE P-6300 ASSEMBLY

170-02181

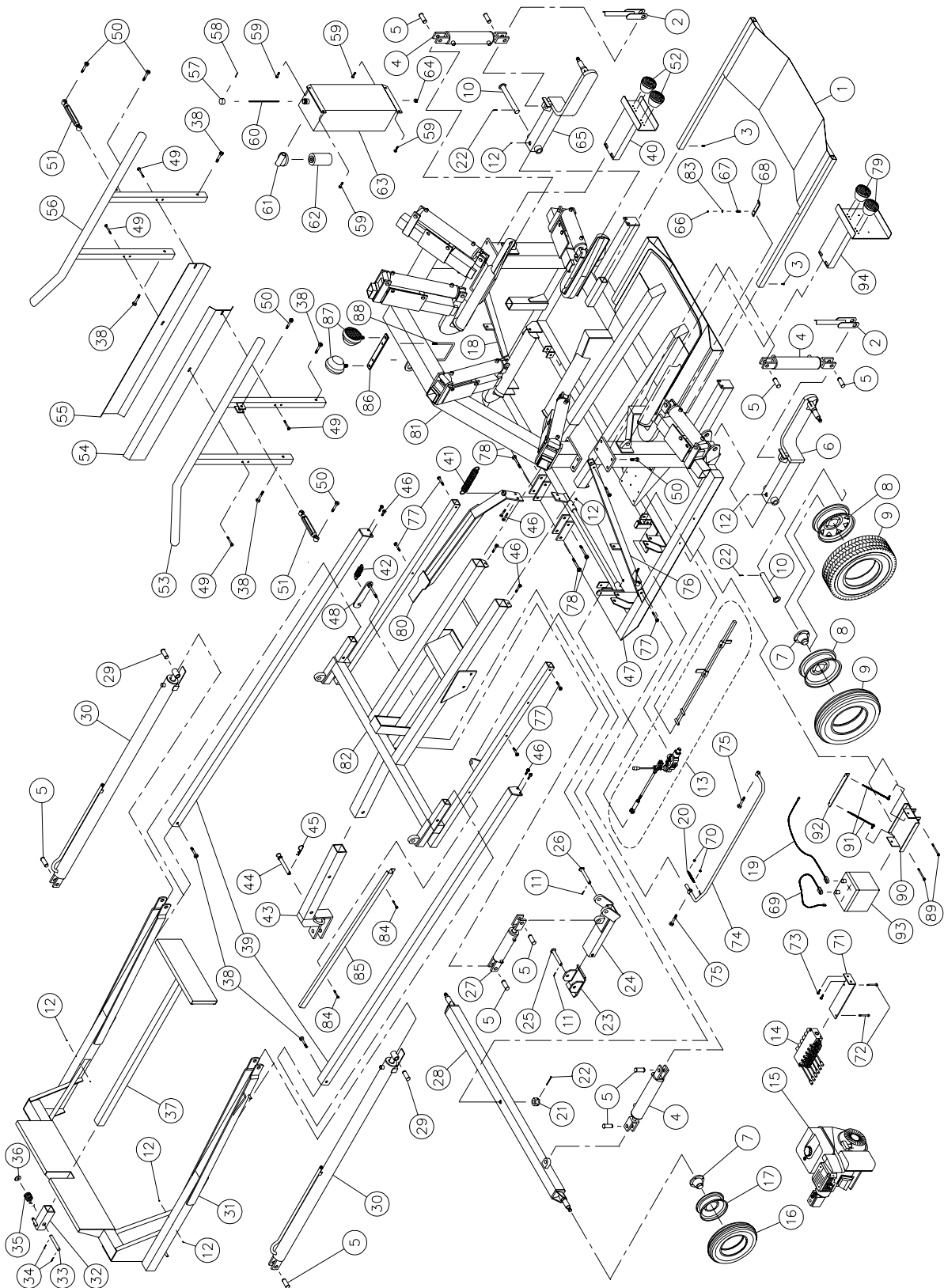

SILATUBE P-6300 ASSEMBLY (cont'd)

REF.	PART #	DESCRIPTION	QTY
1	32107	Tube support plate	1
2	32108	Safety locking mechanism for rear wheels	2
3	Std.	Bolt 1/4" NC x 3/4" lg + nylon locknut	2
4	25TR08	Cylinder 2.5" x 8" standard (see details p. 36)	3
5	D-60051	Pin 1" x 3" lg	10
6	110-11961	Left rear axle	1
7	32218	Hub H-2500 (see details p. 41)	4
8	R-1565	Rim 15 x 6 x 5	2
8	R-1575RT	Rim 15 x 7 x 5 (2)	opt.
9	PN-7.6015	Tire 6.7 x 15 - 8 ply + tube 7.6 x 15 TR-15	2
9	PN-7.0015RT	Tire 7.00 x 15 (2)	opt.
10	32093	Pin for rear axle	2
11	Std.	Cotter pin 5/32" x 1 3/4" lg	2
12	Std.	Grease 1/4"-28 fitting	8
13	---	Automatic system detail (see details p. 32)	1
14	32111	6 spool control valve (see details p. 37)	1
15	---	HONDA 9 HP engine assembled with pump (see details p. 39)	1
15	---	HONDA 9 HP engine with electric starter assembled with pump (see details p. 39)	opt.
16	PN-20.58	Tire 20.5 x 8 x 10 - 4 ply	2
17	R-1065	Rim 10 x 6 x 5	2
18	160-02081	Arch brace (right side)	1
19	51606	Battery cable 4G x 30" lg	opt.
20	16107	Extension spring	1
21	32114	Castle nut 1" - 8	1
22	Std.	Cotter pin 5/32" x 2"	3
23	32115	Base, hydraulic jack	1
24	32116	Body, hydraulic jack	1
25	32117	Pin for hydraulic jack base	1
26	32118	Pin for hydraulic jack body	1
27	25TR04	Cylinder 2.5 x 4" standard (see details p. 36)	1
28	110-03461	Front axle assembly	1
29	32019	Pin 1"	2
30	20172	Cylinder 2" x 72" lg (see details p. 35)	2
31	32216	Bale ram frame	1
32	32121	Ram extension support	1
33	32122	Pin	1
34	Std.	Cotter pin 3/16" x 1 3/4" lg	2
35	32123	Ram extension support spring	1
36	Std.	Washer 1"	1
37	32124	Ram extension	1
38	Std.	Bolt 5/8" NC x 3 1/2" lg + nylon locknut	6
39	32022	Ram guide	2
40	110-03501	Right support for flasher	opt.
41	1201	Tension spring 1/4" x 1 13/16" x 10 1/2" lg	1
42	32008	Tension spring 1 1/4" x 3 1/2" lg	1
43	32199	Drawbar	1
44	32024	Drawbar pin	1
45	Std.	Hitch pin clip 5/32"	1
46	Std.	Bolt 1/2" NC x 1 1/2" lg + nylon locknut	8
47	32217	P-6300 main frame	1
48	32128	Locking mechanism for jack	1
49	Std.	Bolt 7/16" NC x 3" lg + nylon locknut + flat washer	4
50	Std.	Bolt 5/8" NC x 2 1/2" lg + nylon locknut	12
51	32014	Turnbuckle 10"	2
52	32229	2 Right flashers	opt.
53	32165	Left bale guide	1

SILATUBE P-6300 ASSEMBLY (cont'd)

REF.	PART #	DESCRIPTION	QTY
54	130-04281	Left protector	1
55	130-04271	Right protector	1
56	32166	Right bale guide	1
57	32029	Oil reservoir cap	1
58	Std.	Roll pin 5/32" x 1 3/4"	1
59	Std.	Bolt 7/16" NC x 1" + nylon locknut	4
60	32030	Dip stick	1
61	32031	Hydraulic oil filter adaptor FSP107-1E DNN	1
62	32007	Paper filter K-22001	1
63	110-06241	Oil reservoir	1
64	32032	Drain plug 1/2"	1
65	110-11971	Right rear axle	1
66	Std.	Nylon locknut 1/4" NC	1
67	32130	Compression spring 13/32" x 1 1/2" lg	1
68	32131	Locking device for support plate	1
69	51607	Battery cable 4G x 10" lg	opt.
70	Std.	Nylon locknut 5/16" NC	2
71	110-11651	Valve support	1
72	Std.	Bolt 5/16" NC x 2 1/2" lg + nylon locknut	2
73	Std.	Bolt 7/16" NC x 3/4" lg + lock washer & flat washer	2
74	110-06302	Guard	1
75	Std.	Bolt 5/8" NC x 3" lg + nylon locknut	2
76	160-00271	Arch brace (left side)	1
77	Std.	Bolt 1/2" NC x 3 1/2" lg + nylon locknut	8
78	Std.	Bolt 5/8" NC x 4 1/2" lg + nylon locknut	4
79	32228	2 Left flashers with license light	opt.
80	32213	Trigger	1
81	120-00031	Arch frame	1
82	32215	Support structure for ram guide	1
83	Std.	Flat washer 1/4" i.d. x 9/16" o.d.	1
84	Std.	Bolt 3/8" NC x 2 3/4" lg + nylon locknut & flat washer	2
85	32207	Guard	1
86	140-02901	Working lights retaining plate	opt.
87	110-04771	2 Working lights	opt.
88	150-00971	"U" bolt 3/8" NC + 2 nylon locknut	opt.
89	Std.	2 Bolts 5/16" NC x 4" lg + nylon locknut	opt.
90	110-04831	Battery support	opt.
91	110-11511	2 Threaded rods for battery hold down + nylon locknut 3/8" NC and 7/16" NC	opt.
92	130-05751	Battery hold down	opt.
93	32283	Battery 12V-540A	opt.
94	110-03511	Left support for flasher	opt.

SILATUBE P-6302 ASSEMBLY

170-02721

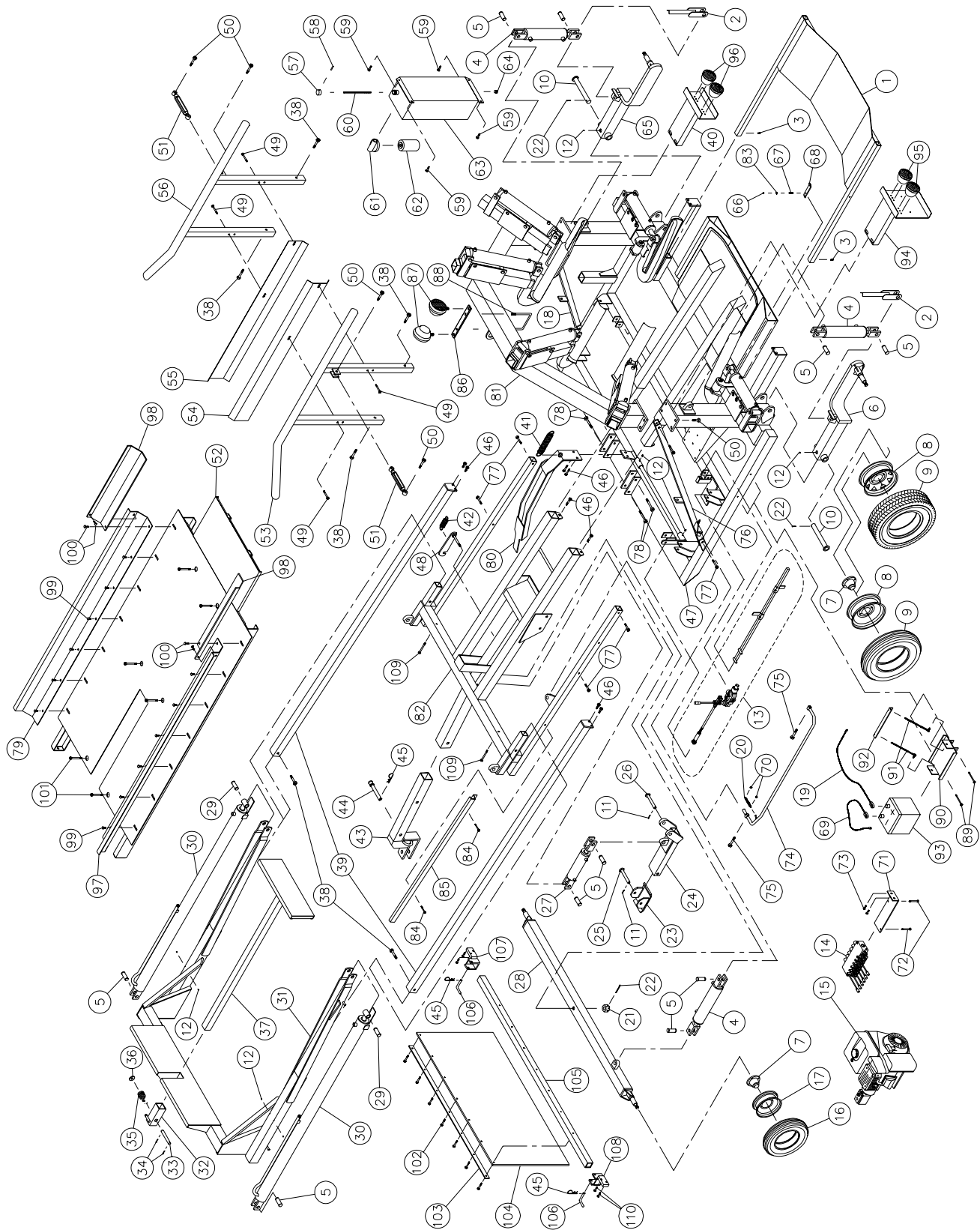

SILATUBE P-6302 ASSEMBLY (cont'd)

REF.	PART #	DESCRIPTION	QTY
1	110-17241	Tube support plate	1
2	32108	Safety locking mechanism for rear wheels	2
3	Std.	Bolt 1/4" NC x 3/4" lg + nylon locknut	2
4	25TR08	Cylinder 2.5" x 8" standard (see details p. 36)	3
5	D-60051	Pin 1" x 3" lg	10
6	110-11961	Left rear axle	1
7	32218	Hub H-2500 (see details p. 41)	4
8	R-1565	Rim 15 x 6 x 5	2
8	R-1575RT	Rim 15 x 7 x 5 (2)	opt.
9	PN-7.6015	Tire 6.7 x 15 - 8 ply + tube 7.6 x 15 TR-15	2
9	PN7.0015RT	Tire 7.00 x 15 (2)	opt.
10	32093	Pin for rear axle	2
11	Std.	Cotter pin 5/32" x 1 3/4" lg	2
12	Std.	Grease 1/4"-28 fitting	8
13	---	Automatic system detail (see details p. 32)	1
14	32111	6 spool control valve (see details p. 37)	1
15	---	HONDA 9 HP engine assembled with pump (see details p. 39)	1
15	---	HONDA 9 HP engine with electric starter assembled with pump (see details p. 39)	opt.
16	PN-20.58	Tire 20.5 x 8 x 10 - 4 ply	2
17	R-1065	Rim 10 x 6 x 5	2
18	160-02081	Arch brace (right side)	1
19	51606	Battery cable 4G x 30" lg	opt.
20	16107	Extension spring	1
21	32114	Castle nut 1" - 8	1
22	Std.	Cotter pin 5/32" x 2"	3
23	32115	Base, hydraulic jack	1
24	32116	Body, hydraulic jack	1
25	32117	Pin for hydraulic jack base	1
26	32118	Pin for hydraulic jack body	1
27	25TR04	Cylinder 2.5 x 4" standard (see details p. 36)	1
28	110-03461	Front axle assembly	1
29	32019	Pin 1"	2
30	20172	Cylinder 2" x 72" lg (see details p. 35)	2
31	120-03691	Bale ram frame	1
32	32121	Ram extension support	1
33	32122	Pin	1
34	Std.	Cotter pin 3/16" x 1 3/4" lg	2
35	32123	Ram extension support spring	1
36	Std.	Washer 1"	1
37	32124	Ram extension	1
38	Std.	Bolt 5/8" NC x 3 1/2" lg + nylon locknut	6
39	32022	Ram guide	2
40	110-03501	Right support for flasher	opt.
41	1201	Tension spring 1/4" x 1 13/16" x 10 1/2" lg	1
42	32008	Tension spring 1 1/4" x 3 1/2" lg	1
43	32199	Drawbar	1
44	32024	Drawbar pin	1
45	Std.	Hitch pin clip 5/32"	3
46	Std.	Bolt 1/2" NC x 1 1/2" lg + nylon locknut	8
47	120-03741	P-6302 main frame	1
48	32128	Locking mechanism for jack	1
49	Std.	Bolt 7/16" NC x 3" lg + nylon locknut + flat washer	4
50	Std.	Bolt 5/8" NC x 2 1/2" lg + nylon locknut	12
51	32014	Turnbuckle 10"	2
52	120-03751	Platform	1
53	32165	Left bale guide	1
54	130-04281	Left protector	1

SILATUBE P-6302 ASSEMBLY (cont'd)

REF.	PART #	DESCRIPTION	QTY
55	130-04271	Right protector	1
56	32166	Right bale guide	1
57	32029	Oil reservoir cap	1
58	Std.	Roll pin 5/32" x 1 3/4"	1
59	Std.	Bolt 7/16" NC x 1" + nylon locknut	4
60	32030	Dip stick	1
61	32031	Hydraulic oil filter adaptor FSP107-1E DNN	1
62	32007	Paper filter K-22001	1
63	110-06241	Oil reservoir	1
64	32032	Drain plug 1/2"	1
65	110-11971	Right rear axle	1
66	Std.	Nylon locknut 1/4" NC	1
67	32130	Compression spring 13/32" x 1 1/2" lg	1
68	32131	Locking device for support plate	1
69	51607	Battery cable 4G x 10" lg	opt.
70	Std.	Nylon locknut 5/16" NC	2
71	110-11651	Valve support	1
72	Std.	Bolt 5/16" NC x 2 1/2" lg + nylon locknut	2
73	Std.	Bolt 7/16" NC x 3/4" lg + lock washer & flat washer	2
74	110-06302	Guard	1
75	Std.	Bolt 5/8" NC x 3" lg + nylon locknut	2
76	160-00271	Arch brace (left side)	1
77	Std.	Bolt 1/2" NC x 3 1/2" lg + nylon locknut	8
78	Std.	Bolt 5/8" NC x 4 1/2" lg + nylon locknut	4
79	130-14472	Right bale guide	1
80	110-16981	Trigger	1
81	120-03781	Arch frame	1
82	32215	Support structure for ram guide	1
83	Std.	Flat washer 1/4" i.d. x 9/16" o.d.	1
84	Std.	Bolt 3/8" NC x 2 3/4" lg + nylon locknut & flat washer	2
85	32207	Guard	1
86	140-02901	Working lights retaining plate	opt.
87	110-04771	2 Working lights	opt.
88	150-00971	"U" bolt 3/8" NC + 2 nylon locknut	opt.
89	Std.	2 Bolts 5/16" NC x 4" lg + nylon locknut	opt.
90	110-04831	Battery support	opt.
91	110-11511	2 Threaded rods for battery hold down + nylon locknut 3/8" NC and 7/16" NC	opt.
92	130-05751	Battery hold down	opt.
93	Std.	Battery 12V-540A	opt.
94	110-03511	Left support for flasher	opt.
95	32228	2 Left flashers with license light	opt.
96	32229	2 Right flashers	opt.
97	130-14473	Left bale guide	1
98	190-04271	Bale guide extension	2
99	Std.	Carriage bolt 7/16" NC x 1" lg + nylon locknut + flat washer	12
100	Std.	Carriage bolt 7/16" NC x 1 1/4" lg + nylon locknut + flat washer	4
101	Std.	Bolt 1/2" NC x 4" lg + nylon locknut	6
102	Std.	Bolt 1/4" NC x 3" lg + nylon locknut	7
103	140-11621	Front flap support	1
104	190-04281	Rubber flap	1
105	160-08001	Rear flap support	1
106	150-03501	Pin for flap support	2
107	110-17031	Right mounting bracket for flap support	1
108	110-17032	Left mounting bracket for flap support	1
109	Std.	Bolt 7/16" NC x 4" lg + nylon locknut	2
110	Std.	Bolt 3/8" NC x 1 1/2" lg + nylon locknut	4

DETAIL OF ARCH MODEL P-6200

170-00751

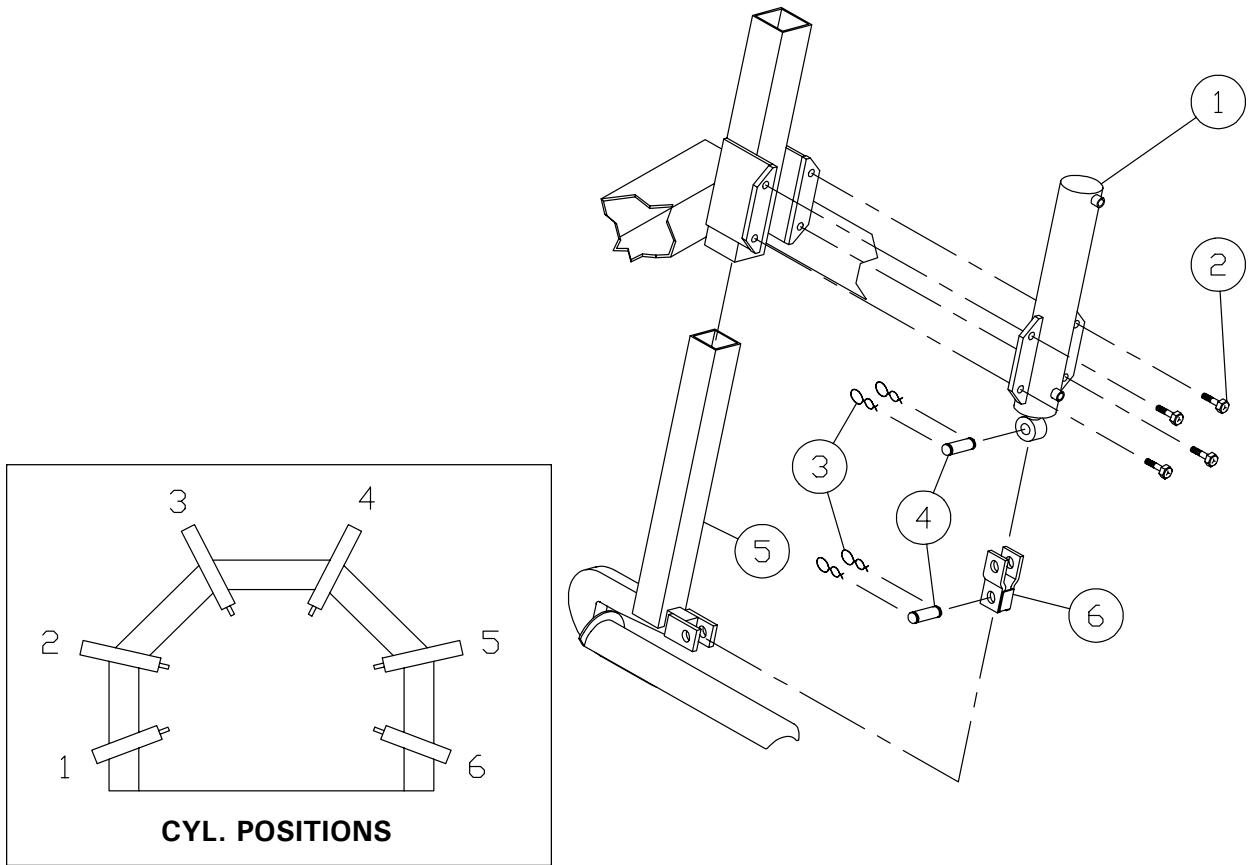

REF.	PART #	DESCRIPTION	QTY CYL. POSITION #					
			1	2	3	4	5	6
1	30Z10	Cylinder	1	-	-	-	-	1
1	30Z15	Cylinder	-	1	-	-	1	-
1	30Z17	Cylinder	-	-	1	1	-	-
2	Std.	Bolt 5/8" NC x 2" lg + nylon locknut	4	4	4	4	4	4
3	Std.	Hair pin 1/8"	2	2	2	2	2	2
4	Std.	Pin 1"	1	1	1	1	1	1
5	110-12171	Stretcher arm (from serial # 1766 and up)	1	-	-	-	-	1
5	110-12181	Stretcher arm (from serial # 1766 and up)	-	1	1	1	1	-
6	110-06171	Adaptor for 44" to 50" bales (optional)	-	-	1	1	-	-
		(includes 2 no. 3 & 1 no. 4)						

8

DETAIL OF ARCH MODEL P-6300

170-00761

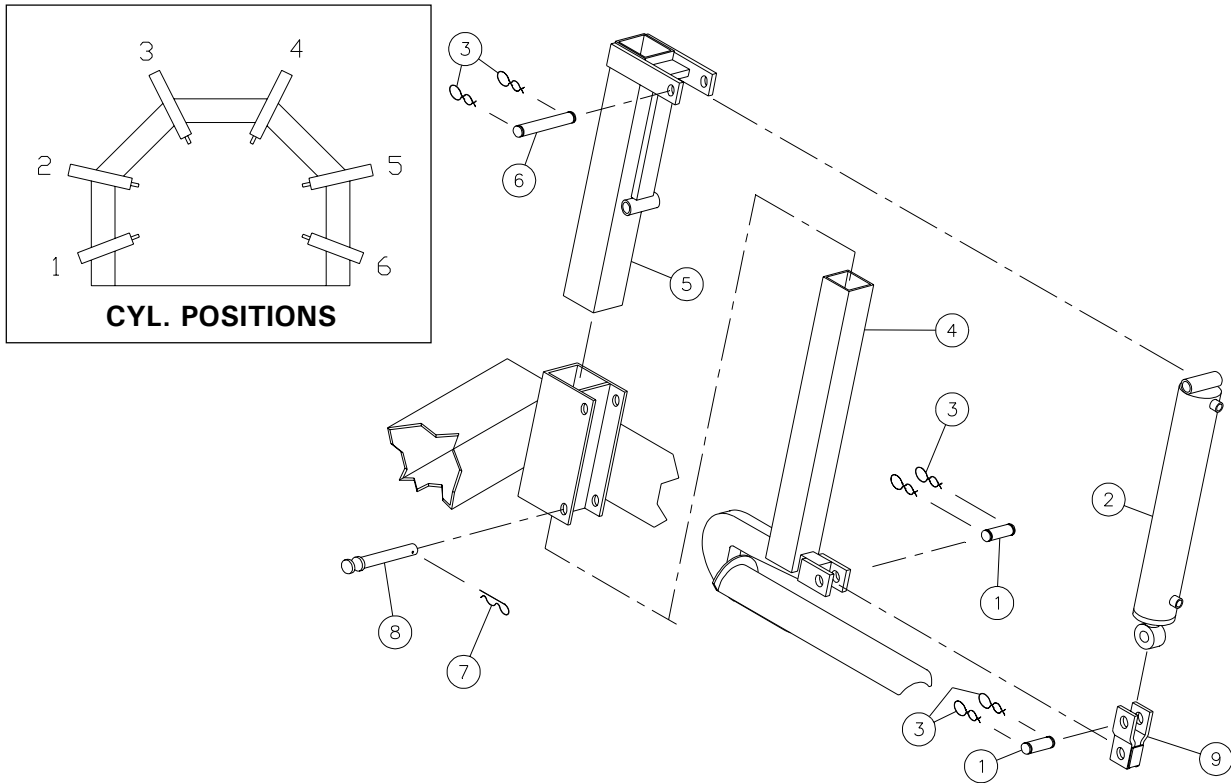

REF.	PART #	DESCRIPTION	QTY CYL POSITION #					
			1	2	3	4	5	6
1	Std.	Pin 1" x 3" lg	1	1	1	1	1	1
2	30H10	Cylinder	1	-	-	-	-	1
2	30H17	Cylinder	-	1	1	1	1	-
3	Std.	Hair pin 1/8"	4	4	4	4	4	4
4	110-12191	Stretcher arm (from serial # 1766 and up)	1	-	-	-	-	1
4	110-12201	Stretcher arm (from serial # 1766 and up)	-	1	-	-	1	-
4	110-12211	Stretcher arm (from serial # 1766 and up)	-	-	1	1	-	-
5	110-06131	Stretcher arm guide	1	-	-	-	-	1
5	110-06141	Stretcher arm guide	-	1	-	-	1	-
5	32159	Stretcher arm guide	-	-	1	1	-	-
6	32160	Pin 1" x 5" lg	1	1	1	1	1	1
7	Std.	Hitch pin clip 3/16"	1	1	1	1	1	1
8	32161	Pin 1" x 5 1/4" lg	1	1	1	1	1	1
9	110-06181	Adaptor for 44" to 50" bales (optional)	-	-	1	1	-	-
(includes 1 no. 1 & 2 no. 3)								

8

DETAIL OF ARCH MODEL P-6302

170-02781

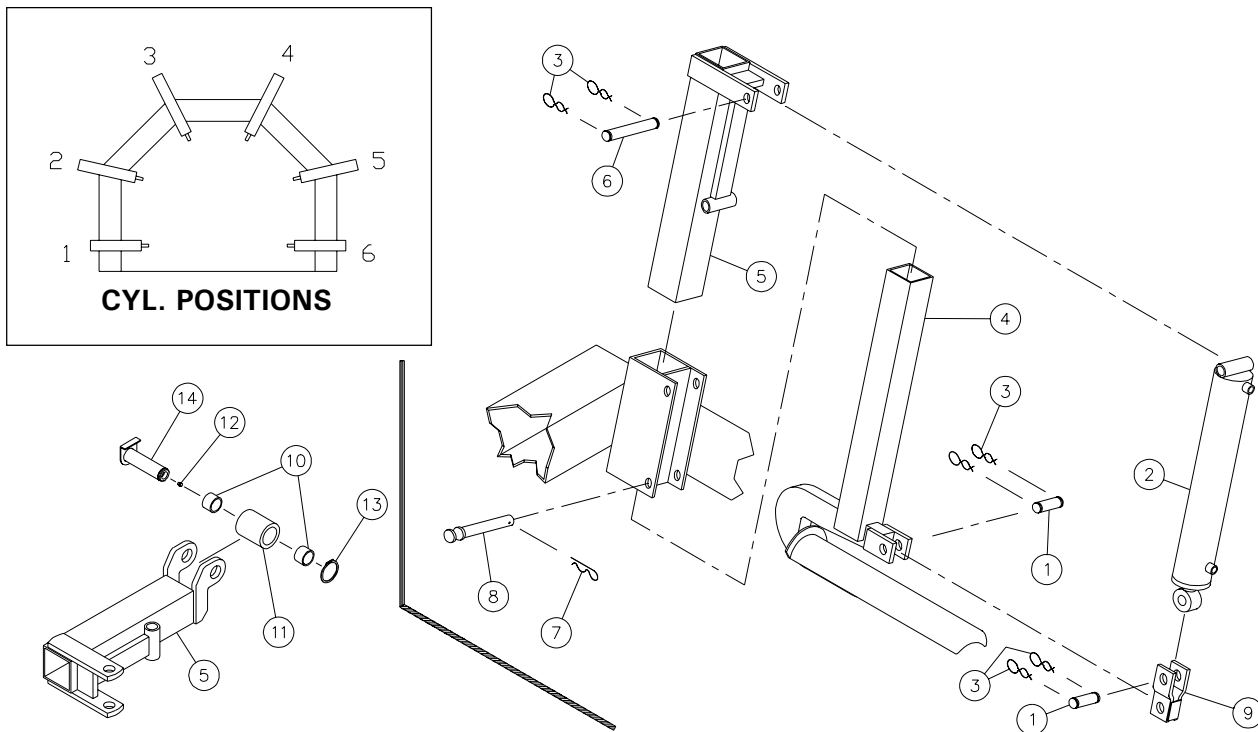

REF.	PART #	DESCRIPTION	QTY POSTE #					
			1	2	3	4	5	6
1	Std.	Pin 1" x 3" lg	1	1	1	1	1	1
2	30H10	Cylinder	1	-	-	-	-	1
2	30H17	Cylinder	-	1	1	1	1	-
3	Std.	Hair pin 1/8"	4	4	4	4	4	4
4	110-16861	Stretcher arm	1	-	-	-	-	1
4	110-16871	Stretcher arm	-	1	-	-	1	-
4	110-12211	Stretcher arm	-	-	1	1	-	-
5*	110-17161	Left stretcher arm guide	1	-	-	-	-	-
5*	110-17162	Right stretcher arm guide	-	-	-	-	-	1
5	110-06141	Stretcher arm guide	-	1	-	-	1	-
5	32159	Stretcher arm guide	-	-	1	1	-	-
6	32160	Pin 1" x 5" lg	1	1	1	1	1	1
7	Std.	Hitch pin clip 3/16"	1	1	1	1	1	1
8	32161	Pin 1" x 5 1/4" lg	1	1	1	1	1	1
9	110-06181	Adaptor for 44" to 50" bales (optional)	-	-	1	1	-	-
		(including 1 no. 1 and 2 no. 3)						
10	160-08011	Bushing aluminium bronze 1 1/4" i.d. x 1 1/2" o.d. x 1" lg	2	-	-	-	-	2
11	150-03521	Roller 2 1/2" o.d. x 3 1/16" lg	1	-	-	-	-	1
12	Std.	Grease fitting 1/4" - 28 straight	1	-	-	-	-	1
13	Std.	External C-clip 1 1/4"	1	-	-	-	-	1
14	110-17151	Pin 1 1/4" x 4 3/4" lg	1	-	-	-	-	1

* must be cut in the event of a replacement and replacement guide must be welded

AUTOMATIC SYSTEM DETAIL

170-00351

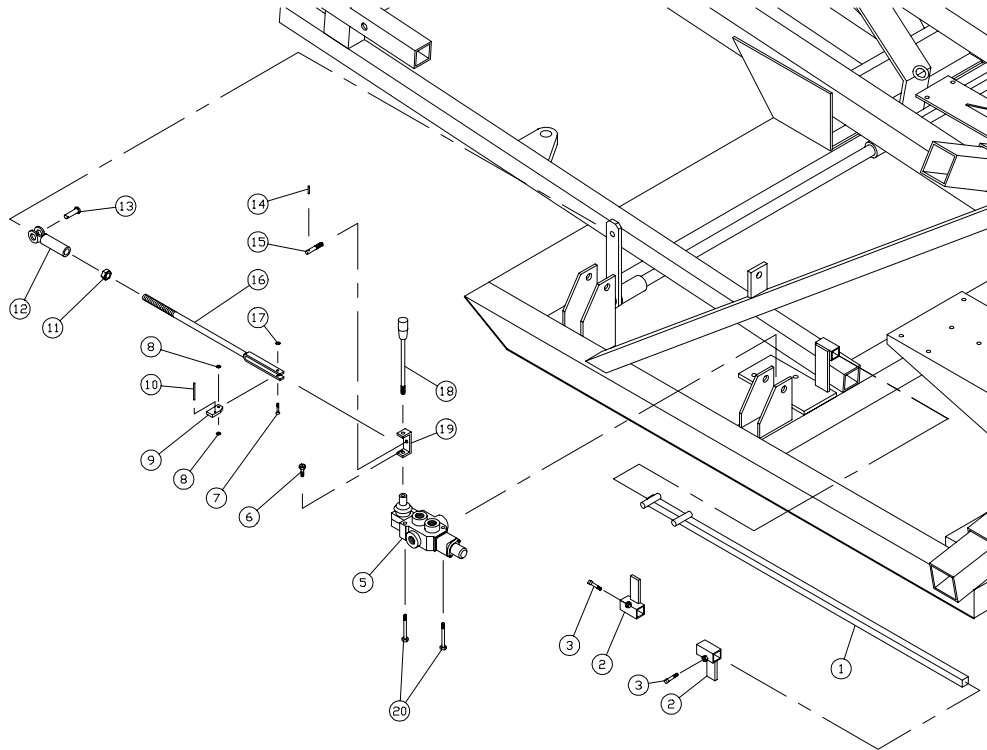

REF.	PART #	DESCRIPTION	QTY		
			P-6200	P-6300	P-6302
1	110-06321	Rod (P-6200)	1	-	-
1	110-06311	Rod (P-6300)	-	1	1
2	32141	Stopper	2	2	2
3	Std.	Square head set screw 5/16" NC x 3/4" lg	2	2	2
5	32232	1 spool control valve (see details p. 34)	1	1	1
6	Std.	Bolt M8 x 1.25 x 16mm lg + lock washer	1	1	1
7	Std.	Flat head screw 10-24 UNC x 1" lg + nylon locknut	1	1	1
8	32144	Flat washer 3/16 (brass)	2	2	2
9	32145	Lever	1	1	1
10	Std.	Roll pin 5/32" X 1 1/4" lg	1	1	1
11	Std.	Nut 1/2" NF	1	1	1
12	51435	Clevis 1/2" NF	1	1	1
13	51436	Pin 1/2" ø x 1 3/4" lg + cotter pin 1/8" x 3/4" lg	1	1	1
14	Std.	Roll pin 5/32" x 3/4" lg	1	1	1
15	32146	Valve actuator pin + 2 nut 5/16" NC + lock washer	1	1	1
16	32147	Rod (P-6200)	1	-	-
16	32148	Rod (P-6300)	-	1	1
17	32149	Lock washer 3/16"	1	1	1
18	649-00009	Spool handle + 2 nut M8 x 1.25	1	1	1
19	190-01651	Spool handle support	1	1	1
20	Std.	Bolt 5/16"NC x 2 1/2" lg + nylon locknut & flat washer	2	2	2

8

ARCH CYLINDER P-6200

15022

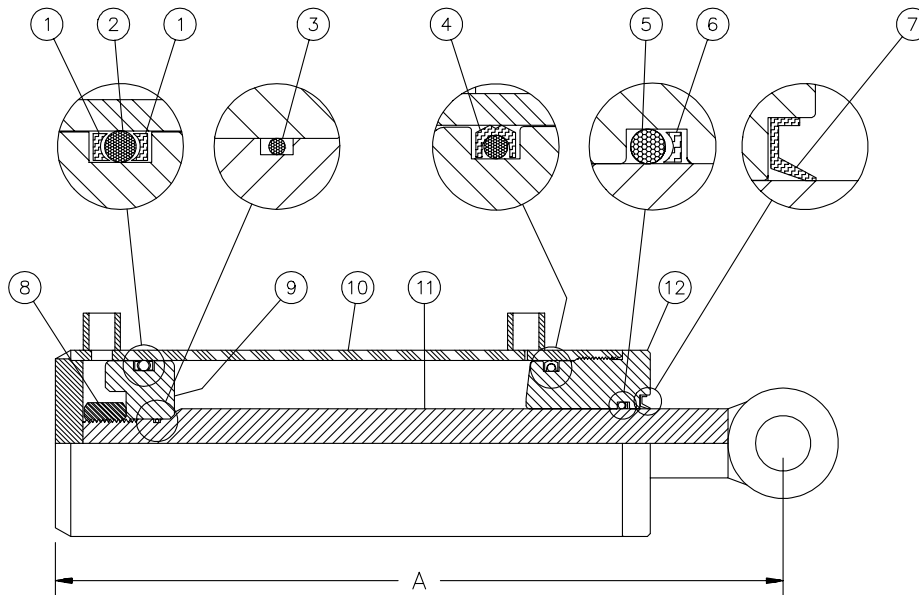

<u>MODEL</u>	<u>LENGTH A</u>
30Z10	16"
30Z15	21"
30Z17	23"

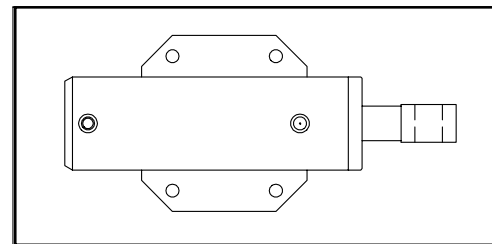

REF.	PART #	DESCRIPTION	QTY CYLINDER #		
			30Z10	30Z15	30Z17
1	BU-334	Back-up ring 3/16" x 2 5/8" x 3"	2	2	2
2	OR-334	O-ring 3/16" x 2 5/8" x 3"	2	2	2
3	OR-018	O-ring 1/16" x 3/4" x 7/8"	1	1	1
4	PSP-334	O-ring "heavy duty" 3/16" x 2 5/8" x 3"	1	1	1
5	OR-218	O-ring 1/8" x 1 1/4" x 1 1/2"	1	1	1
6	BU-218	Back-up ring 1/8" x 1 1/4" x 1 1/2"	1	1	1
7	CR12330	Wiper 1/8" x 1 1/4" x 1 1/2"	1	1	1
8	Std.	Nut 7/8" NF	1	1	1
9	D-6000	Piston 3" dia.	1	1	1
10	D-6096	Cylinder body 3" for 30Z10	1	-	-
10	D-6097	Cylinder body 3" for 30Z15	-	1	-
10	D-6098	Cylinder body 3" for 30Z17	-	-	1
11	D-6099	Piston rod 1 1/4" for 30Z10 and 30H10	1	-	-
11	D-6100	Piston rod 1 1/4" for 30Z15 and 30H15	-	1	-
11	D-6101	Piston rod 1 1/4" for 30Z17 and 30H17	-	-	1
12	D-6093	Head 3" dia.	1	1	1
NI*	32204	Repair kit for cylinder 3" (includes # 1, 2, 3, 4, 5, 6, & 7) ...	1	1	1

NI = Not illustrated

ARCH CYLINDER P-6300 & P-6302

15102

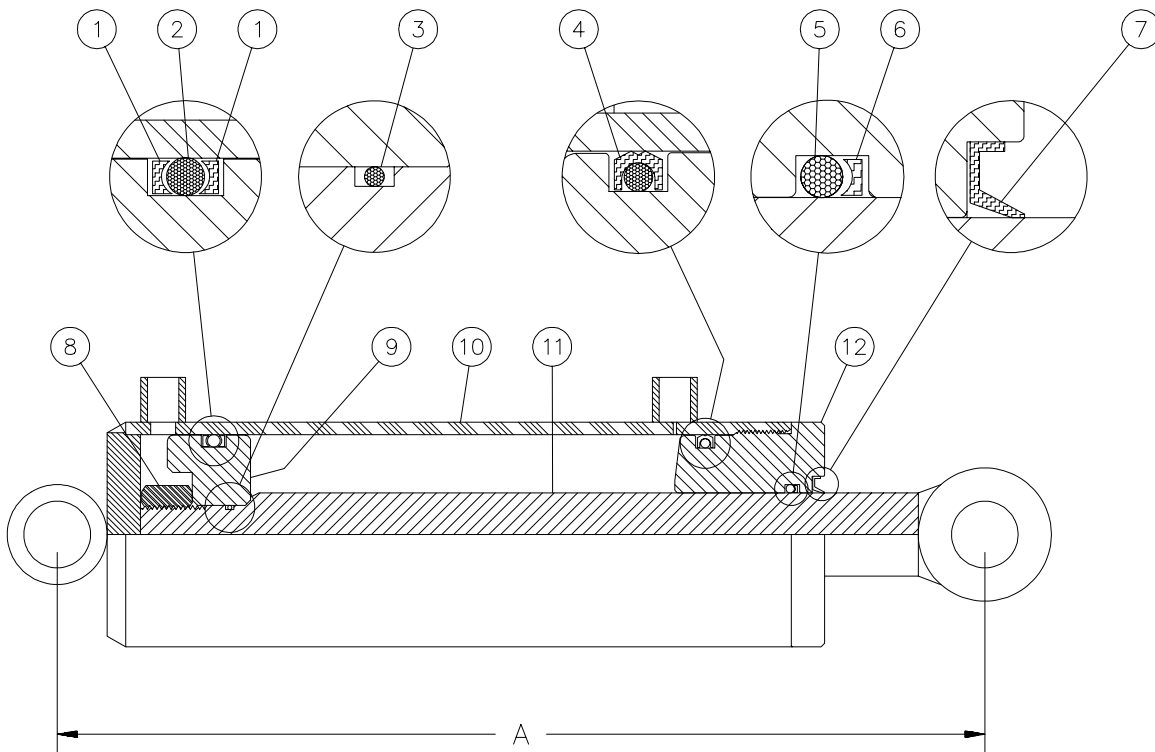

MODEL	LENGTH A
30H10	16 3/4"
30H17	23 3/4"

REF.	PART #	DESCRIPTION	QTY CYLINDER #	
			30H10	30H17
1	BU-334	Back-up ring 3/16" x 2 5/8" x 3"	2	2
2	OR-334	O-ring 3/16" x 2 5/8" x 3"	2	2
3	OR-018	O-ring 1/16" x 3/4" x 7/8"	1	1
4	PSP-334	O-ring "heavy duty" 3/16" x 2 5/8" x 3"	1	1
5	OR-218	O-ring 1/8" x 1 1/4" x 1 1/2"	1	1
6	BU-218	Back-up ring 1/8" x 1 1/4" x 1 1/2"	1	1
7	CR12330	Wiper 1/8" x 1 1/4" x 1 1/2"	1	1
8	Std.	Nut 7/8" NF	1	1
9	D-6000	Piston 3" dia.	1	1
10	D-6168	Cylinder body 3" for 30H10	1	-
10	D-6170	Cylinder body 3" for 30H17	-	1
11	D-6099	Piston rod 1 1/4" for 30Z10 and 30H10	1	-
11	D-6101	Piston rod 1 1/4" for 30Z17 and 30H17	-	1
12	D-6093	Head 3" dia.	1	1
NI*	32204	Repair kit for cylinder 3" (includes # 1, 2, 3, 4, 5, 6, & 7)	1	1

NI = Not illustrated

8

PUSHER CYLINDER # 20I72

15094

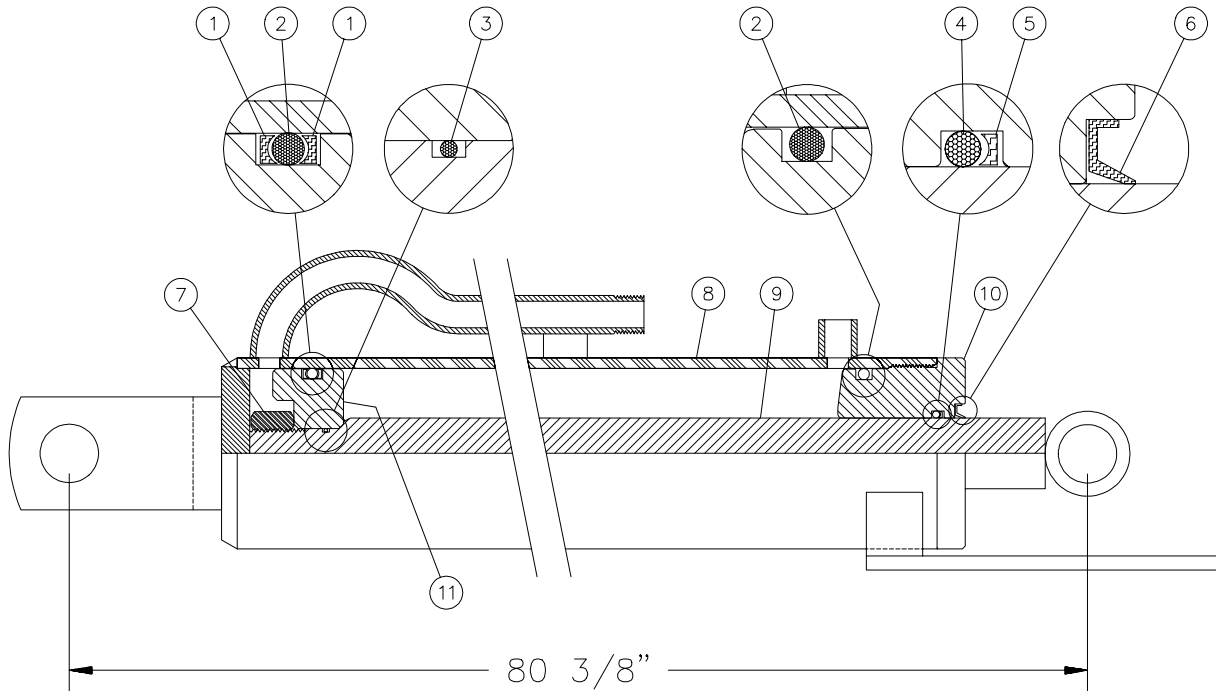

REF.	PART #	DESCRIPTION	QTY
			20172
1	BU-326	Back-up ring 3/16" x 1 5/8" x 2"	2
2	OR-326	O-ring 3/16" x 1 5/8" x 2"	2
3	OR-016	O-ring 1/16" x 5/8" x 3/4"	1
4	OR-218	O-ring 1/8" x 1 1/4" x 1 1/2"	1
5	BU-218	Back-up ring 1/8" x 1 1/4" x 1 1/2"	1
6	CR12330	Wiper 1/8" x 1 1/4" x 1 1/2"	1
7	Std.	Nut 3/4" NF	1
8	D-6179	Cylinder body 2" ø	1
9	D-6172	Piston rod 1 1/4" ø for 20G72 & 20I72	1
10	D-6032	Head 2" ø	1
11	D-6020	Piston 2" ø	1
NI*	32203	Repair kit for cylinder 2" (includes # 1, 2, 3, 4, 5, & 6)	1

NI = Not illustrated

8

CYLINDER 25TR04 & 25TR08

170-01811

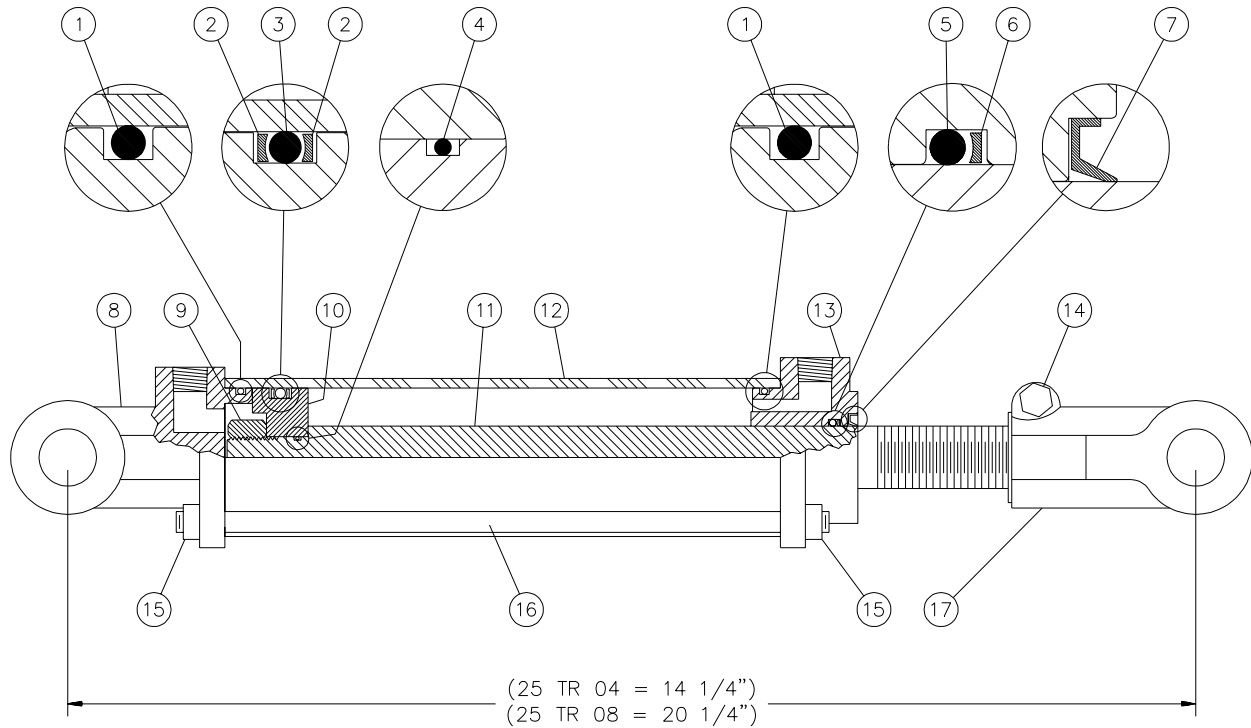

REF.	PART #	DESCRIPTION	QTY	
			25TR04	25TR08
1	Voir RK25TR	O-ring 1/8" x 2 1/4" x 2 1/2"	2	2
2	Voir RK25TR	Back-up 2 1/2" o.d. x 1/8" ø	2	2
3	Voir RK25TR	O-ring 3/16" x 2 1/8" x 2 1/2"	1	1
4	Voir RK25TR	O-ring 1/16" x 5/8" x 3/4"	1	1
5	Voir RK25TR	O-ring 1/8" x 1 1/8" x 1 3/8"	1	1
6	Voir RK25TR	Back-up 1 3/8" o.d. x 1/8" ø	1	1
7	Voir RK25TR	Wiper 1 1/8" i.d. x 1 5/8" o.d.	1	1
8	492401	Yoke (for 2 1/2" tube)	1	1
9	Std.	Nut 3/4" NF	1	1
10	4924-31	Piston 2 1/2" ø	1	1
11	491980-04	Piston rod 1 1/8"	1	-
11	492028	Piston rod 1 1/8"	-	1
12	491668-04	Cylinder body 2 1/2" ø	1	-
12	491668	Cylinder body 2 1/2" ø	-	1
13	492421	Head (for 2 1/2" tube)	1	1
14	Std.	Bolt 3/8" NC x 2 1/4" + nut	1	1
15	Std.	Nut 3/8" NC	8	8
16	Std.	Threaded rod 3/8" NC 8 3/8" lg	4	-
16	Std.	Threaded rod 3/8" NC 12 3/8" lg	-	4
17	458599	Yoke (for 1 1/8" rod)	1	1
NI*	8183	Pin 1" ø + cotter pin	2	2
NI*	RK25TR	Repair kit for cylinder 2 1/2" (includes # 1, 2, 3, 4, 5, 6, & 7)	1	1

*NI = NON ILLUSTRÉ



6 SPOOL CONTROL VALVE # 32111

170-01841

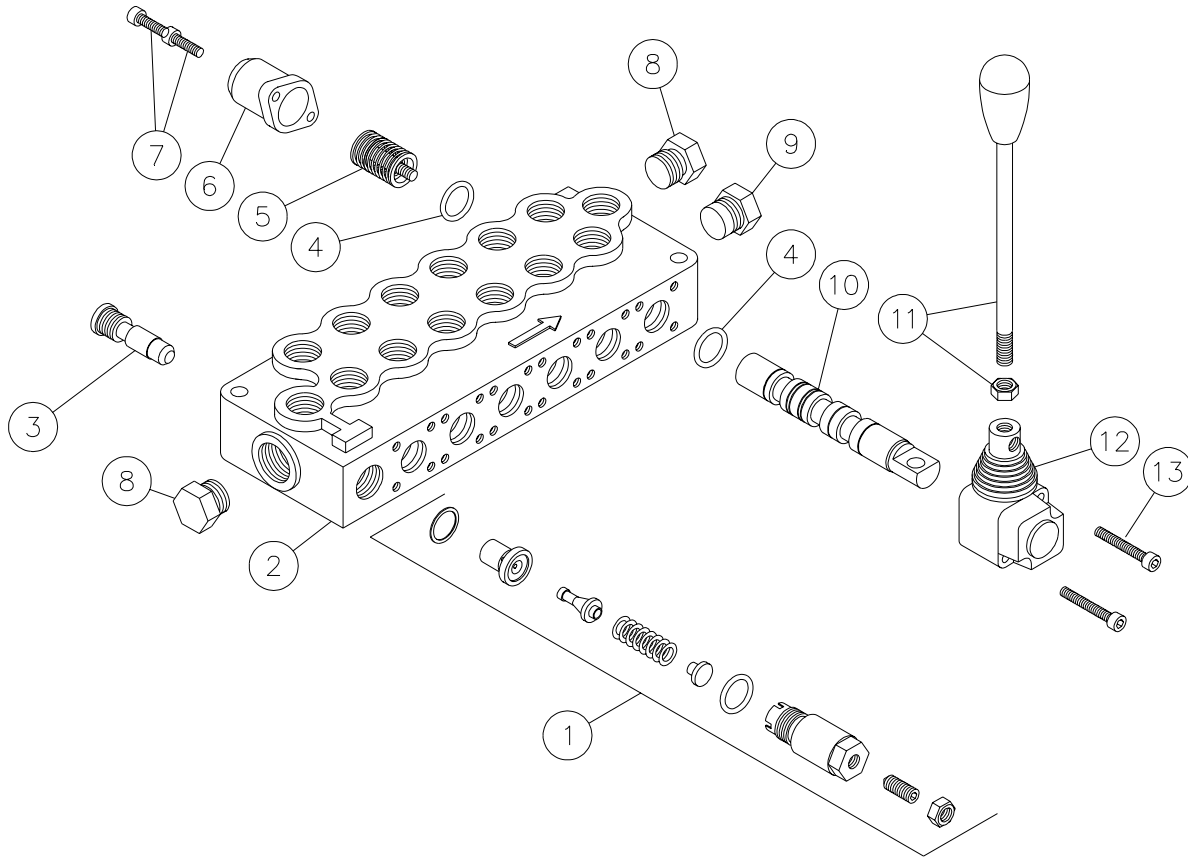

REF.	PART #	CODE #	DESCRIPTION	QTY
1	32275	5KIT105413	Relief valve	1
2	32168	3CO1357000	Valve housing	1
3	32076	XKIT005000	Kit VR5	1
4	32077	4GUA115926	O-ring	12
5	32078	XV08105000	Spring	6
6	32079	3CAP210370	Endcap	6
7	32080	4VIT605014	Screw M5 x 14	12
8	32081	3XTAP822150	Plug SAE8	2
9	32082	3XTAP623170	Plug (open center)	1
10	32085	3CU1210130	Valve spool	6
11	32274	- - - - -	Lever	6
12	32086	3XLEV105000	Lever endcap	6
13	32087	4VIT605035	Screw M5 x 35	12

8

1 SPOOL CONTROL VALVE # 32232 (SD4 modified)

170-01851

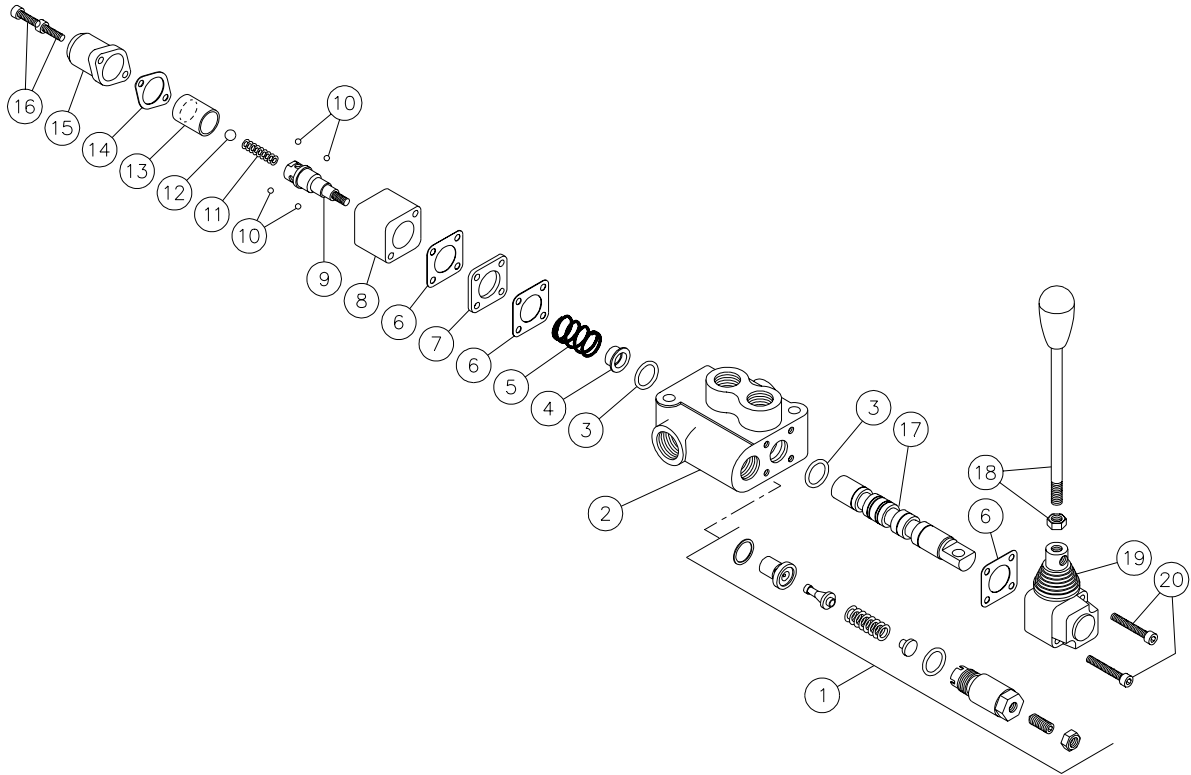

REF.	PART #	CODE #	DESCRIPTION	QTY
1	32275	5KIT105413	Relief valve	1
2	32233	-----	Valve housing	1
3	32077	4GUA115926	O-ring	2
4	32191	3BOC119130	Ring	1
5	32234	-----	Spring	1
6	32276	3GUA136031	Square gasket	3
7	32192	3DIS121035	Aluminium spacer	1
8	32187	3CAP220331	Cap	1
9	32189	3PER115571	Pin	1
10	32182	4SFE204762	Ball 4.762	4
11	32188	3MOL208280	Spring	1
12	32183	4SFE209525	Ball 9.525	1
13	32186	3BUS221271	Ring	1
14	32277	3GUA136032	Oval gasket	1
15	32079	3CAP210370	Endcap	1
16	32184	4VIT605050	Bolt M5 x 50	2
17	32193	3CU1110120	Spool	1
18	32274	-----	Lever	1
19	32086	3XLEV105000	Lever endcap	1
20	32087	4VIT605035	Bolt M5 x 35	2
NI*	21CSD4		Repair kit (includes # 3 to 16)	1

Some parts might not be available separately

*NI = Not illustrated

8

ENGINE ASSEMBLY WITH PUMP

170-00321

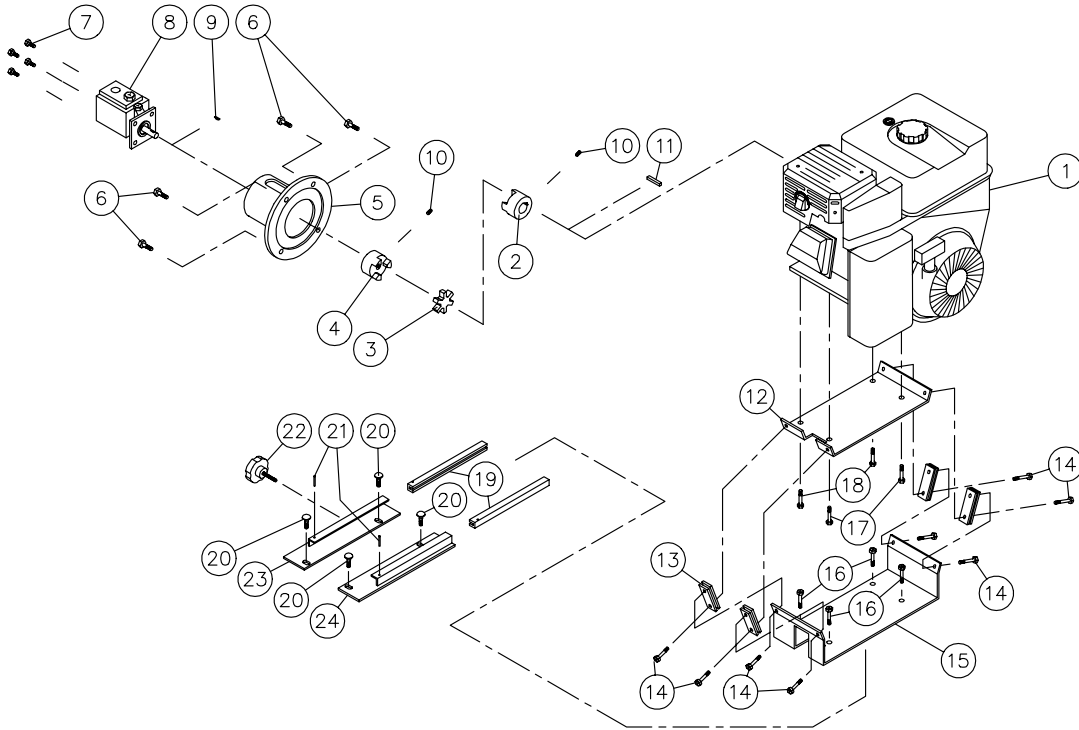

REF.	PART #	DESCRIPTION	QTY SILATUBES		
			P-6200	P-6300	P-6302
1	32230	Engine HONDA 9HP	1	1	1
1	32257	Engine HONDA 9HP with electric starter	opt.	opt.	opt.
2	32133	Flexible coupling 1" ø	1	1	1
3	32134	Flexible coupling	1	1	1
4	32135	Flexible coupling ½" ø	1	1	1
5	32136	Mounting flange	1	1	1
6	Std.	Bolt 3/8" NC x 1" lg + lock washer	4	4	4
7	Std.	Bolt 5/16" NC x 3/4" lg + lock washer	4	4	4
8	32002	Pump	1	1	1
9	Std.	Woodruff key 1/8"	1	1	1
10	Std.	Socket set screw 5/16" NC x 1/2"	2	2	2
11	Std.	Square key 1/4" x 1 1/2" lg	1	1	1
12	32194	Upper motor mounting plate	1	1	1
13	190-03311	Anti-vibration supports	4	4	4
14	Std.	Bolt 5/16" NC x 1" lg + nylon locknut & flat washer	8	8	8
15	32196	Lower motor mounting plate	1	1	1
16	Std.	Bolt 3/8" NC x 1" lg + nylon locknut	4	0	0
17	Std.	Bolt 3/8" NC x 1 ¾" lg + nut & lock washer	2	2	2
18	Std.	Bolt 3/8" NC x 1 ¾" lg + nut & lock washer & flat washer	2	2	2
19	190-00202	Slide engine mount	0	2	2
20	Std.	Carriage bolt 3/8" NC x 1" lg + nylon locknut	0	4	4
21	Std.	Roll pin 1/8" x 1" lg	0	2	2
22	110-00591	Slide handle	0	1	1
23	110-00582	Left mount for slide	0	1	1
24	110-00572	Right mount for slide	0	1	1

HUB H1000

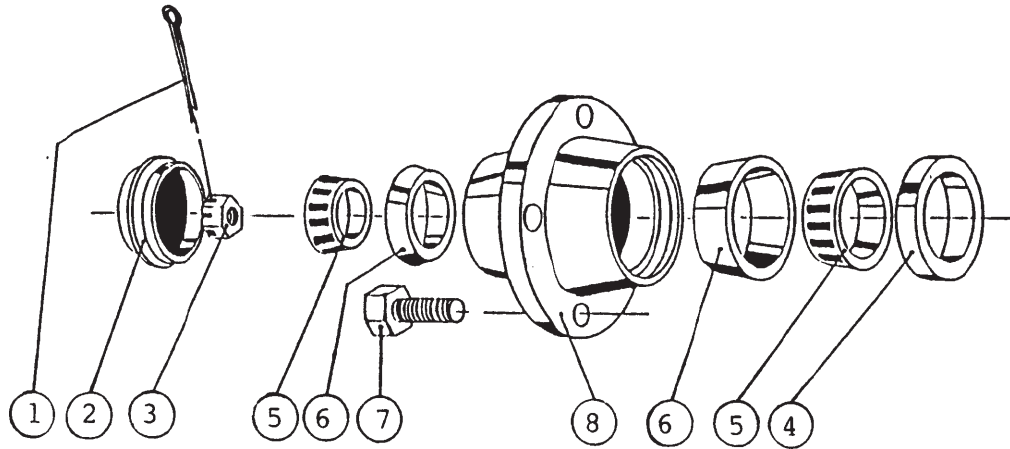

FRONT HUB FOR P-6200

REF.	PART #	DESCRIPTION	QTY
1	Std.	Cotter pin 5/32" x 1 3/4"	1
2	53019	Dust cap 1.973 ø.	1
3	53020	Castle nut 1" NF	1
4	53021	Oil seal no. CR523696	1
5	53022	Roller bearing Timken: cone no. L44643	2
6	53023	Roller bearing Timken: cup no. L44610	2
7	53024	Rim screw 1/2"	4
8	53025	Hub only H1000	1

8

HUB H2500

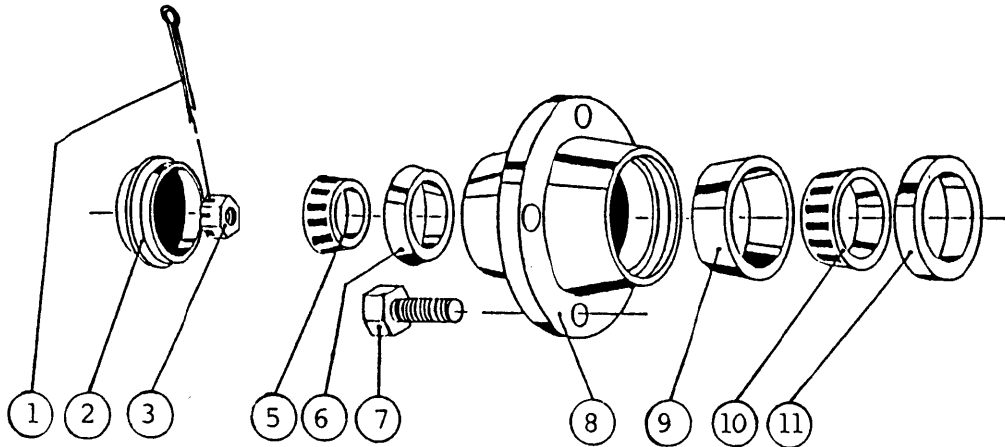

REAR HUB FOR P-6200 & FRONT AND REAR HUB FOR P-6300 AND P-6302

REF.	PART #	DESCRIPTION	QTY
1	Std.	Cotter pin 5/32" x 1 3/4"	1
2	53019	Dust cap D-1000 1.973" ø	1
3	51529	Castle nut 1" NF x 9/16" thick	1
5	53058	Roller bearing Timken: cone no. L44649	1
6	53023	Roller bearing Timken: cup no. L44610	1
7	53024	Rim screw 1/2"	5
8	53059	Hub only H2500	1
9	51415	Roller bearing Timken: cup no. LM48510	1
10	51416	Roller bearing Timken: cone no. LM48548	1
11	51535	Oil seal no. CR17415	1

HYDRAULIC SYSTEM

170-01793

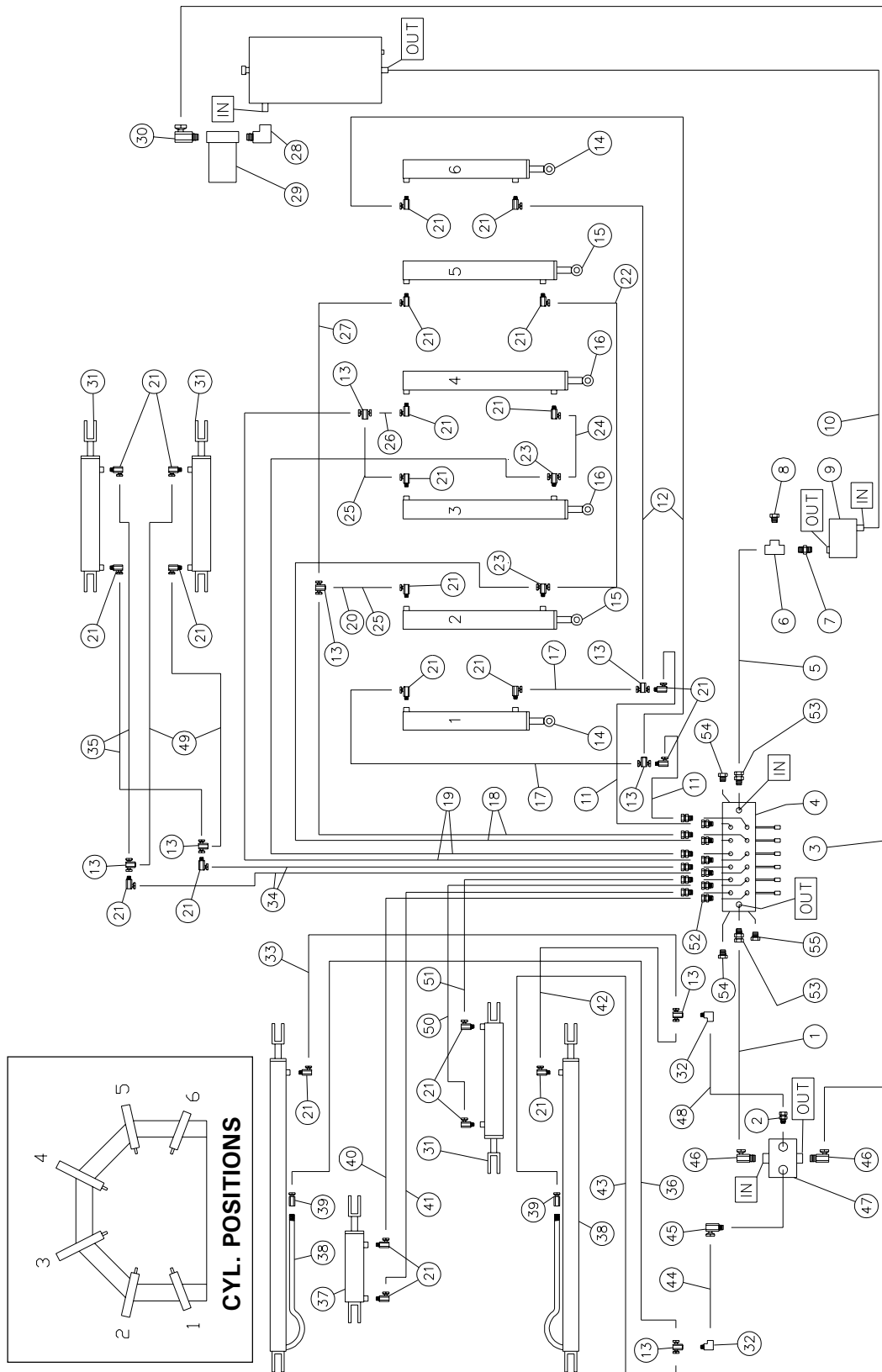

HYDRAULIC SYSTEM (cont'd)

REF.	PART #	DESCRIPTION	QTY		
			P-6200	P-6300	P-6302
1	190-01621	Hose ½" x 90" lg + 2 fittings 8U108	1	1	1
2	Std.	Fitting 9315 8 x 6	15	15	15
3	D-18089	Hose ½" x 140" lg + 2 fittings 8U108	1	1	1
4	32111	6 spool control valve (see details page 33)	1	1	1
5	D-8668	Hose ½" x 38" lg + 2 fittings 8U108	1	1	1
6	Std.	"T" ½" C3709 x 8	1	1	1
7	Std.	Straight female pipe to male pipe ½" C3069 x 8	1	1	1
8	Std.	Plug ½" C3159 x 8	1	1	1
9	32002	Two stages 4/11 hydraulic pump	1	1	1
10	D-8727	Low pressure hose 1" x 116½" lg	1	-	-
10	D-18090	Low pressure hose 1" x 123" lg	-	1	1
11	D-18092	Hose 3/8" x 48" lg + 2 fittings 6U106	2	2	2
12	D-18093	Hose 3/8" x 112" lg + 2 fittings 6U106	2	2	2
13	Std.	"T" swivel 3/8" 15856 x 6	8	8	8
14	30Z10	Cylinder 3" x 10" stroke (see details page 33)	2	-	-
14	30H10	Cylinder 3" x 10" stroke (see details page 34)	-	2	2
15	30Z15	Cylinder 3" x 15" stroke (see details page 33)	2	-	-
15	30H17	Cylinder 3" x 17" stroke (see details page 34)	-	2	2
16	30Z17	Cylinder 3" x 17" stroke (see details page 33)	2	-	-
16	30H17	Cylinder 3" x 17" stroke (see details page 34)	-	2	2
17	D-18097	Hose 3/8" x 29" lg + 2 fittings 6U106	2	2	2
18	D-8675	Hose 3/8" x 31" lg + 2 fittings 6U106	2	-	-
18	190-00001	Hose 3/8" x 48" lg + 2 fittings 6U106	-	2	2
19	D-8676	Hose 3/8" x 58" lg + 2 fittings 6U106	2	-	-
19	D-8760	Hose 3/8" x 64" lg + 2 fittings 6U106	-	2	2
20	D-18096	Hose 3/8" x 11" lg + 2 fittings 6U106	1	-	-
21	Std.	Fitting 9405 6x6	24	24	24
22	190-03131	Hose 3/8" x 154" lg + 2 fittings 6U106	-	1	1
23	Std.	"T" swivel 3/8" 15855 x 6	2	2	2
24	D-8673	Hose 3/8" x 43 ½" lg + 2 fittings 6U106	1	-	-
24	D-18098	Hose 3/8" x 49" lg + 2 fittings 6U106	-	1	1
25	D-18099	Hose 3/8" x 12 ¾" lg + 2 fittings 6U106	1	2	2
26	D-18100	Hose 3/8" x 52" lg + 2 fittings 6U106	1	1	1
27	D-8674	Hose 3/8" x 122 ¾" lg + 2 fittings 6U106	2	-	-
27	D-18101	Hose 3/8" x 148" lg + 2 fittings 6U106	-	1	1
28	Std.	Street elbow 3/4" 90° C3409 x 12	1	1	1
29		Paper filter 32007 + hydraulic oil filter adaptor 32031	1	1	1
30	Std.	Fitting 9205 8x12	1	1	1
31	25TR08	Cylinder 2 ½" x 8" (see details page 36)	3	3	3
32	Std.	Street elbow 3/8" 90° C3409 x 6	2	2	2
33	190-00611	Hose 3/8" x 52" lg + 2 fittings 6U106	1	1	1
34	190-03061	Hose 3/8" x 54" lg + 2 fittings 6U106	2	2	2
35	190-03081	Hose 3/8" x 107" lg + 2 fittings 6U106	2	-	-
35	190-03091	Hose 3/8" x 115" lg + 2 fittings 6U106	-	2	2
36	D-18103	Hose 3/8" x 60" lg + 2 fittings 6U106	1	-	-
36	D-18104	Hose 3/8" x 66" lg + 2 fittings 6U106	-	1	1
37	25TR04	Cylinder 2 ½" x 4" (see details page 36)	1	1	1
38	20172	Cylinder 2" x 72" stroke (see details page 35)	2	2	2

HYDRAULIC SYSTEM (cont'd)

REF.	PART #	DESCRIPTION	QTY		
			P-6200	P-6300	P-6302
39	Std.	Fitting 9255 6x6	2	2	2
40	D-8964	Hose 3/8" x 158" lg + 2 fittings 6U106	1	-	-
40	D-18105	Hose 3/8" x 168" lg + 2 fittings 6U106	-	1	1
41	D-8965	Hose 3/8" x 164" lg + 2 fittings 6U106	1	-	-
41	D-18106	Hose 3/8" x 170" lg + 2 fittings 6U106	-	1	1
42	D-18107	Hose 3/8" x 63" lg + 2 fittings 6U106	1	1	1
43	D-18108	Hose 3/8" x 68" lg + 2 fittings 6U106	1	1	1
44	D-8986	Hose 1/2" x 53" lg + 2 fittings 8U106	1	1	1
45	Std.	Fitting 9515 8x6	1	1	1
46	Std.	Fitting 9515 8x8	2	2	2
47	32232	1 spool valve (see details page 38)	1	1	1
48	190-02021	Hose 1/2" x 53" lg + 1 fittings 8U106 + 1 fitting 22591-8-8	1	-	-
48	190-02011	Hose 1/2" x 57" lg + 1 fittings 8U106 + 1 fitting 22591-8-8	-	1	1
49	190-03071	Hose 3/8" x 34" lg + 2 fittings 6U106	2	2	2
50	D-8985	Hose 3/8" x 138" lg + 2 fittings 6U106	1	1	1
51	D-18085	Hose 3/8" x 122" lg + 2 fittings 6U106	1	1	1
52	Std.	Fitting 9315 6x6	12	12	12
53	Std.	Fitting 9315 8x8	2	2	2
54	Std.	Plug 7238x8	2	2	2
55	Std.	Plug M20x1.5 + o-ring (TN185G-20M)	1	1	1

ELECTRIC CIRCUIT

WORKING LIGHTS

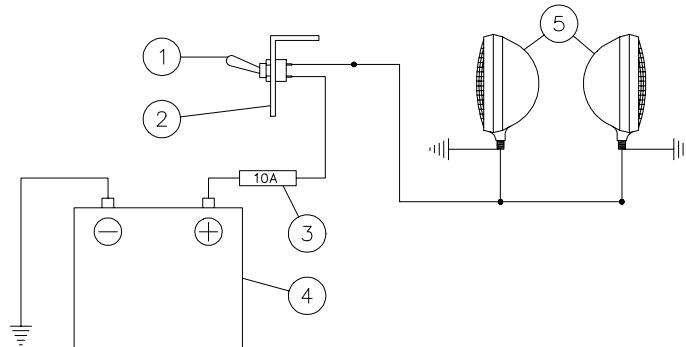

170-00381

REF.	PART #	DESCRIPTION	QTY
1	32237	Switch ON-OFF	1
2	130-04481	Switch support	1
3	Std.	Fuse 10A	1
4	32283	Battery 12V-540A	1
5	110-04771	Working lights	2

ROAD LIGHTS

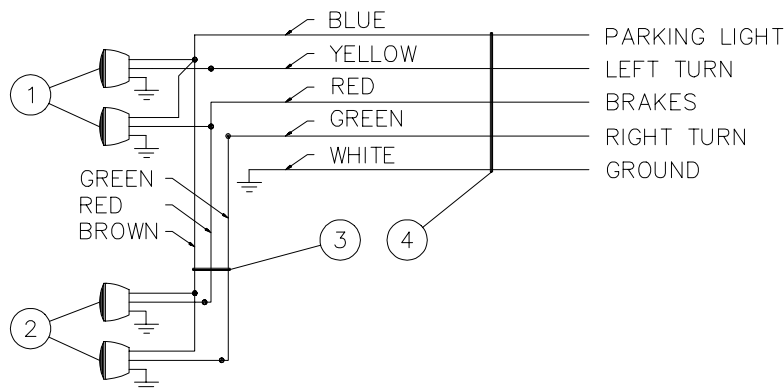

170-00381

REF.	PART #	DESCRIPTION	QTY
1	32228	Left red flashers with license light	2
2	32229	Right red flashers	2
3	110-03601	3 conductors cable with terminal 204" lg	1
4	110-03591	5 conductors cable with terminal 288" lg	1



TRACTION MECHANISM

170-01861

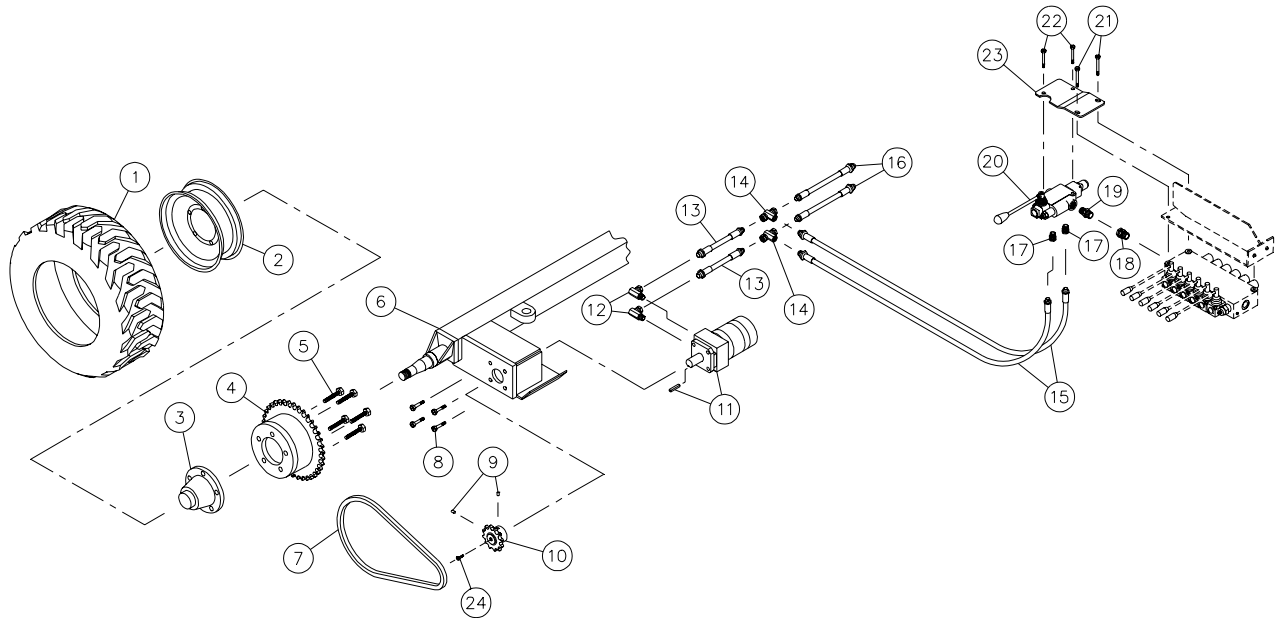

REF.	PART #	DESCRIPTION	QTY		
			P-6200	P-6300	P-6302
1	PNA238512	Traction tire	2	2	2
2	R-1275	Rim 12 x 7 - 5 bolts	2	2	2
3	190-01281	Hub H-2500 modified	2	2	2
4	110-08841	Sprocket 60A38	2	2	2
5	110-10991	Bolt 1/2" NF x 2 3/4" lg + nut	10	10	10
6	110-11791	Front axle for P-6200	1	-	-
6	110-11801	Front axle for P-6300	-	1	1
7	190-02881	Chain #60 x 36" lg	2	2	2
8	Std.	Bolt 3/8" NC x 1" lg + lockwasher	8	8	8
9	Std.	Hexagonal socket set screw 5/16" NC x 1/2" lg	4	4	4
10	110-10981	Sprocket 60B14	1	1	1
11	DH315	Hydraulic motor DH315 + key (see details p. 48)	2	2	2
12	9405x6x8	Fitting 90 deg. (swivel)	2	2	2
13	Std.	Hose 3/8" + 2 fittings 6U-106	2	2	2
14	5856x6x6x6	"T" (swivel)	2	2	2
15	Std.	Hose 3/8" + 2 fittings 6U-106	2	2	2
16	Std.	Hose 3/8" + 2 fittings 6U-106	2	2	2
17	9315x8x6	Straight fitting (swivel)	2	2	2
18	9315x8x8	Straight fitting (swivel)	1	1	1
19	6401x8x8	Straight fitting	1	1	1
20	640-10004	1 spool valve SD-4 (open center) (see details p. 47)	1	1	1
21	Std.	Bolt 5/16" NC x 2 3/4" lg + nylon locknut	2	2	2
22	Std.	Bolt 5/16" NC x 2 1/2" lg + nylon locknut	2	2	2
23	130-13201	Mounting plate	1	1	1
24	Std.	Bolt 1/4" NC x 3/4" lg + stopper	1	1	1

8

1 SPOOL CONTROL VALVE # 640-10004 (SD4 open center)

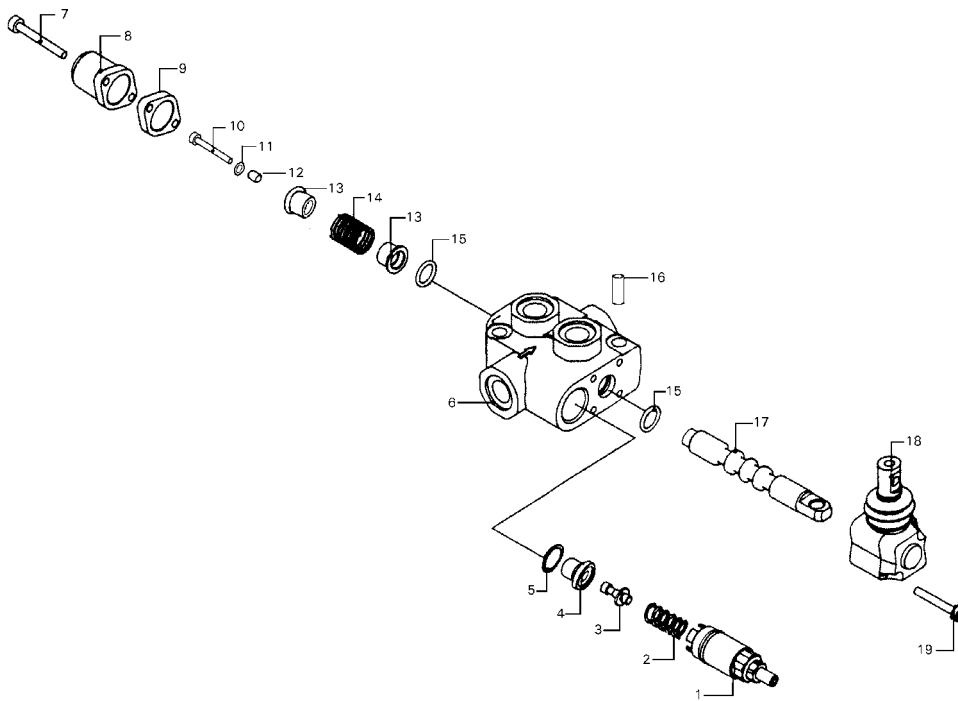

REF.	PART #	CODE #	DESCRIPTION	QTY
1	32167	XKIT105211	Relief valve	1
2	32169	3MOL314341	Spring	1
3	32072	3OTT213260	Spring seat pusher	1
4	32073	3ANE220210	Ring	1
5	32074	3ANE120010	Seal	1
6	32236		Valve housing	1
7	32171	4VIT605018	Bolt M5 x 18	2
8	32079	3CAP210370	Endcap	1
9	32172	3DIS12104N	Spacer	1
10	32173	4VIT508035	Bolt M8 x 35	1
11	32174	3ANE112010	Ring	1
12	32175	3ANE109091	Ring	1
13	32176	3BOC119120	Spring retainer	2
14	32177	3MOL419430	Spring	1
15	32007	4GUA115926	O-ring (121)	1
16	32179	4SPI510022	Roll pin	1
17	32282	3CU1110100	Valve spool	1
18	32086	3XLEV105000	Lever	1

8

HYDRAULIC MOTOR #DH 315

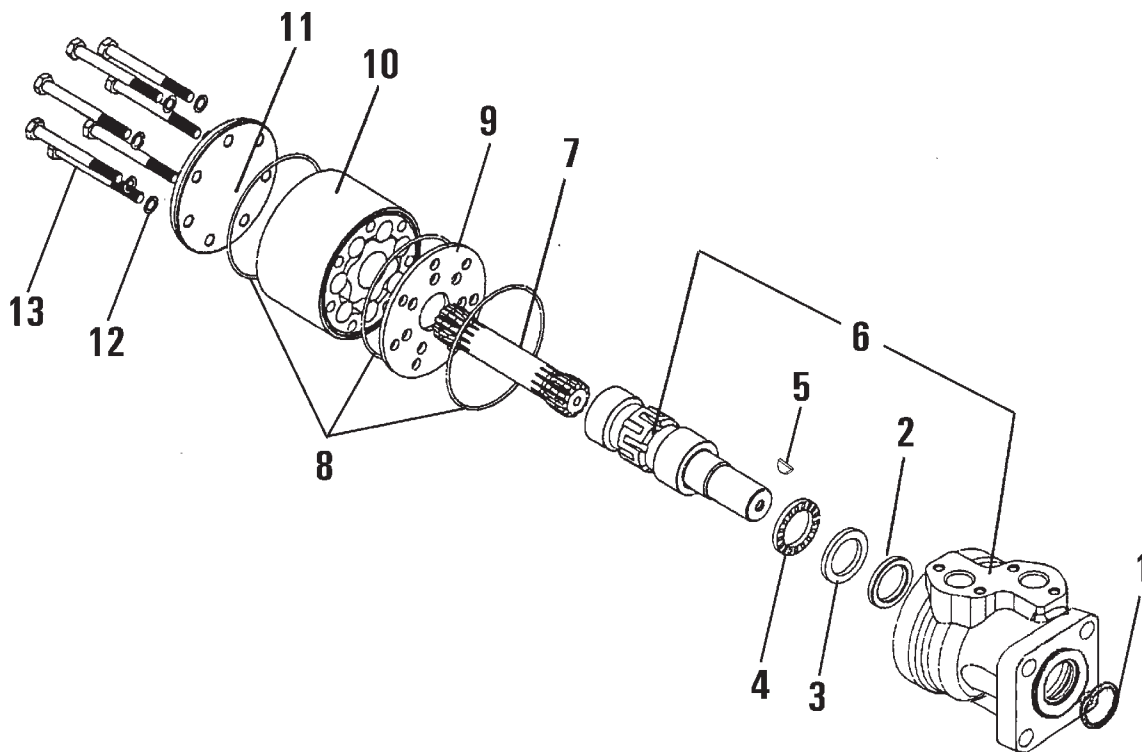







REF.	CODE #	DESCRIPTION	QTY
			DH 315
1	633B0370	Dust seal ring	1
2	633B0414	Shaft seal BAKDH ring	1
3	151-5708	Bearing race	1
4	151-5709	Axial needle bearing	1
5	682L9054	Woodruff key	1
6	-----	Housing and output shaft.....	not sold
7	151-2650	Cardan shaft	1
8	633B1173	O-ring.....	3
9	151-1713	Distributor plate	1
10	151-1186	Gear wheel set	1
11	151-2673	End cover	1
12	684X0076	Washer	6
13	681X0186	Screw M8 x 1.25mm Din 931 x 70mm lg	6
NI*	151-1286	Set of seals.....	1

*NI = NOT ILLUSTRATED





8

TORQUE CHART

TORQUE SPECIFICATION TABLE

Thread UNC and UNF		Grade 2 				Grade 5   				Grade 8*   			
Bolt size		Torque				Torque				Torque			
Inches	mm	Pound feet		Newton meters		Pound feet		Newton meters		Pound feet		Newton meters	
		min.	max.	min.	max.	min.	max.	min.	max.	min.	max.	min.	max.
1/4	6.35	5	6	6.8	8.13	9	11	12.2	14.9	12	15	16.3	30.3
5/16	7.94	10	12	13.6	16.3	17	20.5	23.1	27.8	24	29	32.5	39.3
3/8	9.53	20	23	27.1	31.2	35	42	47.5	57.0	45	54	61.0	73.2
7/16	11.11	30	35	40.7	47.4	54	64	73.2	86.8	70	84	94.9	113.9
1/2	12.70	45	52	61.0	70.5	80	96	108.5	130.2	110	132	149.2	179.0
9/16	14.29	65	75	88.1	101.6	110	132	149.2	179.0	160	192	217.0	260.4
5/8	15.88	95	105	128.7	142.3	150	180	203.4	244.1	220	264	298.3	358.0
3/4	19.05	150	185	203.3	250.7	270	324	366.1	439.3	380	456	515.3	618.3
7/8	22.23	160	200	216.8	271.0	400	480	542.4	650.9	600	720	813.6	976.3
1	25.40	250	300	338.8	406.5	580	696	786.5	943.8	900	1080	1220.4	1464.5
1 1/8	25.58	-	-	-	-	800	880	1084.8	1193.3	1280	1440	1735.7	1952.6
1 1/4	31.75	-	-	-	-	1120	1240	1518.7	1681.4	1820	2000	2467.9	2712.0
1 3/8	34.93	-	-	-	-	1460	1680	1979.8	2278.1	2380	2720	3227.3	3688.3
1 1/2	38.10	-	-	-	-	1940	2200	2630.6	2983.2	3160	3560	4285.0	4827.4

* Thick nuts must be used with grade 8 bolts.

Size of screw	Thread	Pitch (mm)	Grade 4T  				Grade 7T 				Grade 8T  			
			Torque				Torque				Torque			
			Pound feet		Newton meters		Pound feet		Newton meters		Pound feet		Newton meters	
min. max.		min. max.		min. max.		min. max.		min. max.		min. max.				
M6	UNC	1.00	3.6	5.8	4.9	7.9	5.8	9.4	7.9	12.7	7.2	10	9.8	13.6
M8	UNC	1.25	7.2	14	9.8	19	17	22	23	29.8	20	26	27.1	35.2
M10	UNC	1.5	20	25	27.1	33.9	34	40	46.1	54.2	38	46	51.5	62.3
M12	UNC	1.75	28	34	37.9	46.1	51	59	69.1	79.9	57	66	77.2	89.4
M14	UNC	2.0	49	56	66.4	75.9	81	93	109.8	126	96	109	130.1	147.7
M16	UNC	2.0	67	77	90.8	104.3	116	130	157.2	176.2	129	145	174.8	196.5
M18	UNC	2.0	88	100	119.2	136	150	168	203.3	227.6	175	194	237.1	262.9
M20	UNC	2.5	108	130	146.3	176.2	186	205	252	277.8	213	249	288.6	337.4
M8	UNF	1.0	12	17	16.3	23	19	27	25.7	36.6	22	31	29.8	42
M10	UNF	1.25	20	29	27.1	39.3	35	47	47.4	63.7	40	52	54.2	70.5
M12	UNF	1.25	31	41	42	55.6	56	68	75.9	92.1	62	75	84	101.6
M14	UNF	1.5	52	64	70.5	86.7	90	106	122	143.6	107	124	145	168
M16	UNF	1.5	69	83	93.5	112.5	120	138	162.6	187	140	158	189.7	214.1
M18	UNF	1.5	100	117	136	158.5	177	199	239.8	269.6	202	231	273.7	313
M20	UNF	1.5	132	150	178.9	203.3	206	242	279.1	327.9	246	289	333.3	391.6

Use the above torques when special torque is not given.

NOTE: These values apply to fasteners as received from supplier, dry, or when lubricated with normal engine oil. They do not apply if extreme pressure lubricants are used.

WARRANTY

PRONOVOST warrants this product to the initial purchaser for the period of one year from the date of purchase against defects in materials and workmanship.

We will replace or repair defective parts free of charge if they are returned to our plant in St-Tite, Quebec, Canada.

Transportation charges are the responsibility of the customer. This warranty is not transferable.

Tires and gasoline engine are covered by the manufacturers of these items.

All PRONOVOST spare parts purchased are covered by a three (3) month warranty.

This warranty becomes void and nul if the equipment is modified, breaks down as result of an accident, if not operated according to manufacturer's recommendations, damaged by negligence or if maintenance has not been carried out as specified.

Our obligation is limited to the replacement or repair of the defective part. PRONOVOST accepts no responsibility for direct or indirect consequential damages of any kind.

Ce manuel est aussi disponible en français.
Veuillez téléphoner.



INNOVATION - EXCELLENCE

LES MACHINERIES PRONOVOST INC.

260, route 159,

Saint-Tite, Quebec, Canada, G0X 3H0

Tel.: (418) 365-7551, Fax: (418) 365-7954

www.pronovost.qc.ca