

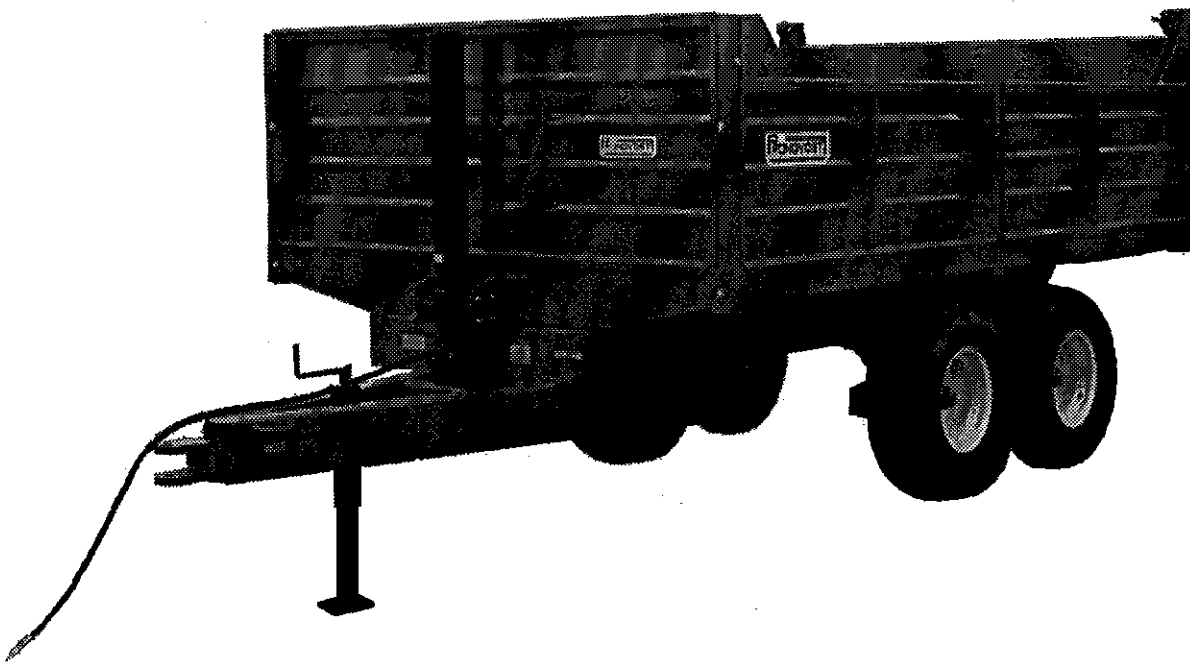

**OPERATOR'S / PARTS
MANUAL**



Dump Trailer
Model

P-524

Copyright © Les Machineries Pronovost Inc., 1998

All rights reserved.
Printed in Canada.

TABLE OF CONTENTS

Section	Item	Page
1	Introduction	5
2	Safety	6
	General Safety	6
	Safety in Operation	6
	Safety with Maintenance	7
	Safety in Transport	7
	Safety in Storage	7
3	Decals	8
	Maintenance Decals	8
4	Start-up	9
	Basic Start-up Procedures	9
5	Maintenance	10
6	Storage	11
7	Specifications	12
8	Parts List	13
	Dump Trailers P-524	13
	Hub H5500	15
	Jack # PC-3012HD	16
9	Torque Chart	17
10	Warranty	18

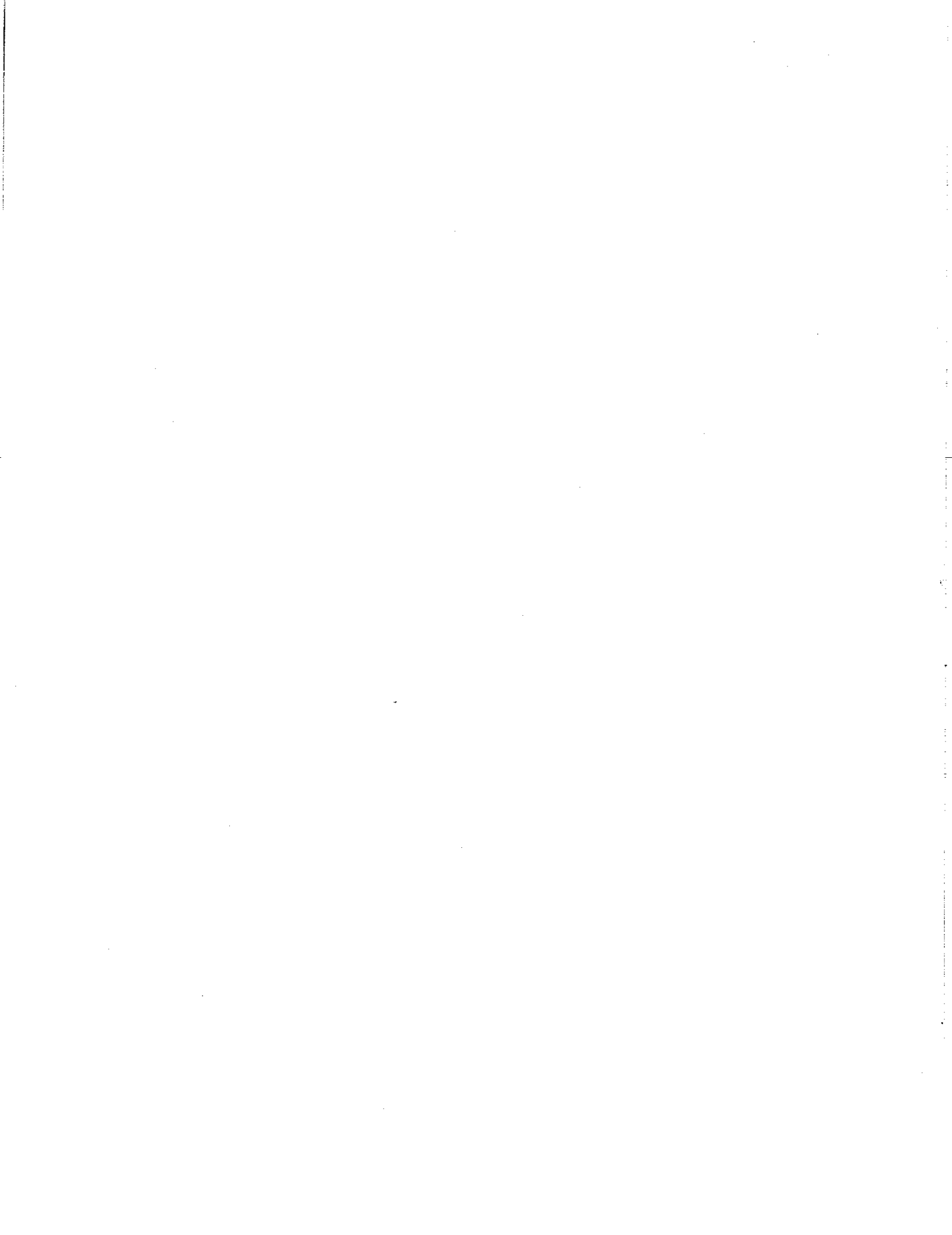

INTRODUCTION

1

CONGRATULATIONS!

Thank you for choosing PRONOVOST. We are confident this equipment will meet your requirements in terms of quality, performance and reliability.

This manual was prepared to assist you in the safe operation of your new Dump Trailer. It contains important information which will help you achieve excellent returns with your PRONOVOST Dump Trailer for years to come.

Please read this manual before operating your Trailer and keep it for future reference.

Before using this equipment, you or any other person who will be using it must familiarize yourself with the safety recommendations, the operating and safety instructions. Please read carefully and be sure to understand and follow all recommendations and procedures.

In this manual, the right and left sides are identified while standing at the rear end of the equipment and facing it.

If you require additional information on your Dump Trailer, please contact your PRONOVOST Dealer.

NOW take a moment to enter the model, serial number and the date of purchase of your Trailer in the space provided below.

When ordering parts from your Dealer, please refer to these numbers for a fast and efficient service. Use PRONOVOST parts for replacement.

The model and serial numbers are on the name plate shown on Fig. 1.

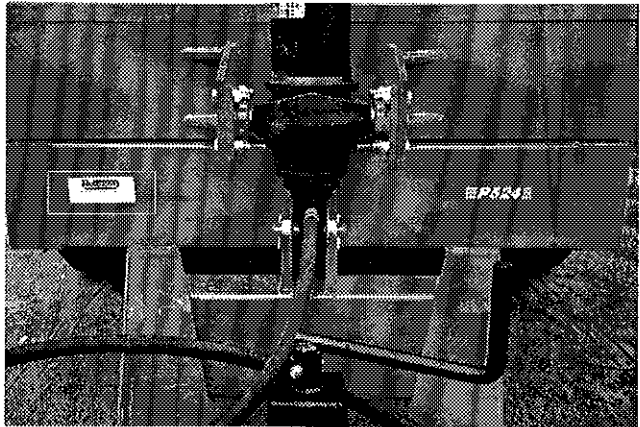

Figure 1

MODEL: _____

SERIAL NO: _____

DATE OF PURCHASE: _____

SAFETY

GENERAL SAFETY

2

WHEN YOU SEE THIS SYMBOL



ATTENTION!

**BE ALERT
YOUR SAFETY IS INVOLVED**

This symbol "SAFETY ALERT" is used in this manual and on the safety decals on the Trailer. It warns you of the possibility of danger. Carefully read, understand and follow all safety recommendations before operating the equipment.

- 1) Careful operation is the best assurance against accidents. Carefully read this manual and follow all recommendations before operating this equipment. It is the owner's responsibility to make sure that anyone who will operate the Trailer will read this manual before operating the equipment.
- 2) Do not modify the equipment. Any non authorized modification may affect the efficiency and/or safety of the equipment.
- 3) Never operate the equipment with defective parts or if damaged in any way. Have it repaired before using it.
- 4) Make sure all fasteners are in place and properly secured or tightened. Refer to torque chart on page 17.

- 5) Hydraulic fluids under pressure can damage your skin. Do not use your hands to locate a leak.

SAFETY IN OPERATION

- 1) **WARNING!** Do not overload your trailer, do not exceed the load capacity indicated in the specifications on page 12.
- 2) Be sure there are no obstructions around the equipment and that no one stands near the equipment when in use.
- 3) Do not operate an engine in a confined or non ventilated area.
- 4) Do not perform any adjustments, cleaning, maintenance or repairs with the engine running on the towing vehicle. Preferably remove the key from the ignition.
- 5) Be careful when backing-up, make sure you have good visibility.
- 6) Do not forget to unlock the proper panel before dumping.
- 7) Always travel at a safe operating speed following regulations and common sense. In the case of agricultural service tires, follow the manufacturer's specified safe speed. The road speed should be such as to maintain full control over steering and braking.

SAFETY (cont'd)

SAFETY WITH MAINTENANCE

- 1) Perform maintenance according to recommendations contained in this manual.
- 2) If the trailer is hooked up to the tractor while performing maintenance work, make sure the engine is not running and preferably remove the ignition key.

SAFETY IN TRANSPORT

- 1) On public roads, use proper safety lights and check local regulations.
- 2) Be alert while driving on the road. Never carry passengers.

SAFETY IN STORAGE

- 1) If the trailer is to be stored for a certain period of time, install wooden blocks under the axles. **THIS WILL AVOID ANY ACCIDENTAL CRUSHING OF ANIMALS OR ANYONE WHO COULD CRAWL UNDER THE EQUIPMENT.**

2

DECALS

MAINTENANCE DECALS

The maintenance decals indicate the points requiring lubrication. Refer to maintenance section for more details.

3

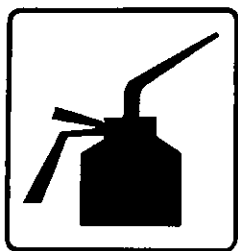

Figure 2

Part no.: A 105



Figure 3

Part no.: A 106

START-UP

BASIC START-UP PROCEDURES

- 1) Lubricate all grease fittings with a good quality multiuse grease.
- 2) Lubricate panel release mechanism, front and rear with good quality oil.
- 3) Adjust tire pressure to manufacturer's specifications.
- 4) Install wheels on hubs.
- 5) Install panels.
- 6) Install all hydraulic hoses and fittings compatible with your equipment.
- 7) Verify for adequate tightness of all fastening devices. Refer to torque chart on page 17.
- 8) Operate the hydraulic system a few times, raising and lowering the platform in order to remove any trapped air in the system. Then check the oil level in the tractor's hydraulic oil reservoir.
- 9) Do not forget to unlock the proper panel before dumping.

4

MAINTENANCE

- 1) Wipe off all grease fittings with a clean cloth before adding grease in order to avoid injecting dirt or sand.
- 2) Repair or replace damaged grease fittings.
- 3) Lubricate all grease fittings every 20 hours of operation.
- 4) Check all bolts on wheels after first 5 hours of operation and then every 50 hours of operation.
- 5) Lubricate panel release mechanism, front and rear, every 20 hours of operation.
- 6) Check tire pressure every 50 hours of operation, adjust according to manufacturer's recommendation indicated on the tires.
- 7) Open, clean and lubricate wheel bearings once a year.
- 8) Check all nuts and bolts once a year. If necessary use torque chart on page 17.

5

STORAGE

- 1) Store in a cool, dry place.
- 2) Install wooden blocks under the axles to keep the tires off the ground and cover them if left exposed to the sun.
- 3) Keep all piston rods in the retracted position. This will assure better protection against the elements.
- 4) Clean your trailer.
- 5) Thoroughly inspect all parts of the trailer. Replace or repair worn or defective parts.
- 6) Touch-up or repaint if necessary.
- 7) Lubricate all points before storage.

SPECIFICATIONS

SERVICE	AGRICULTURAL
MODEL	P-524
Capacity	24000 lbs / 10896 kg
Interior dimensions of box	84" x 138" / 2134 mm x 3505 mm
Height: Side panel 12G *	24" / 610 mm
Height: Front/back panel 12G *	32" / 813 mm
Platform height	39" / 991 mm
Overall length	198 " / 5029 mm
Overall width	90" / 2286 mm
Overall height	63" / 1600 mm
Free height / maximum lift	20" / 508 mm
Thread width	72 1/2" / 1842 mm
Dumping angle (back)	47°
Dumping angle (2 sides)	--
Grain door	Standard
Axle	Tandem
Suspension	--
Hubs	8 bolts
Hub capacity	5500 lbs / 2497 kg
Spindles	2 1/4" / 57 mm
Wheels	4
Wheel dimensions	15 x 10 x 8
Tires (standard)	12,5L15 (10 ply)
Hitch: clevis/swivel	standard
Hitch: ball coupler	opt.: 2 5/16" / 59 mm
Electric brakes	--
Light system (12 V)	--
Oil / volume required	--
Cylinder	SINGLE acting
Hitch weight (empty)	565 lbs / 257 kg
Total weight	3400 lbs / 1542 kg

* Removable panels

Design and specifications subject to change without notice.

DUMP TRAILER P-524

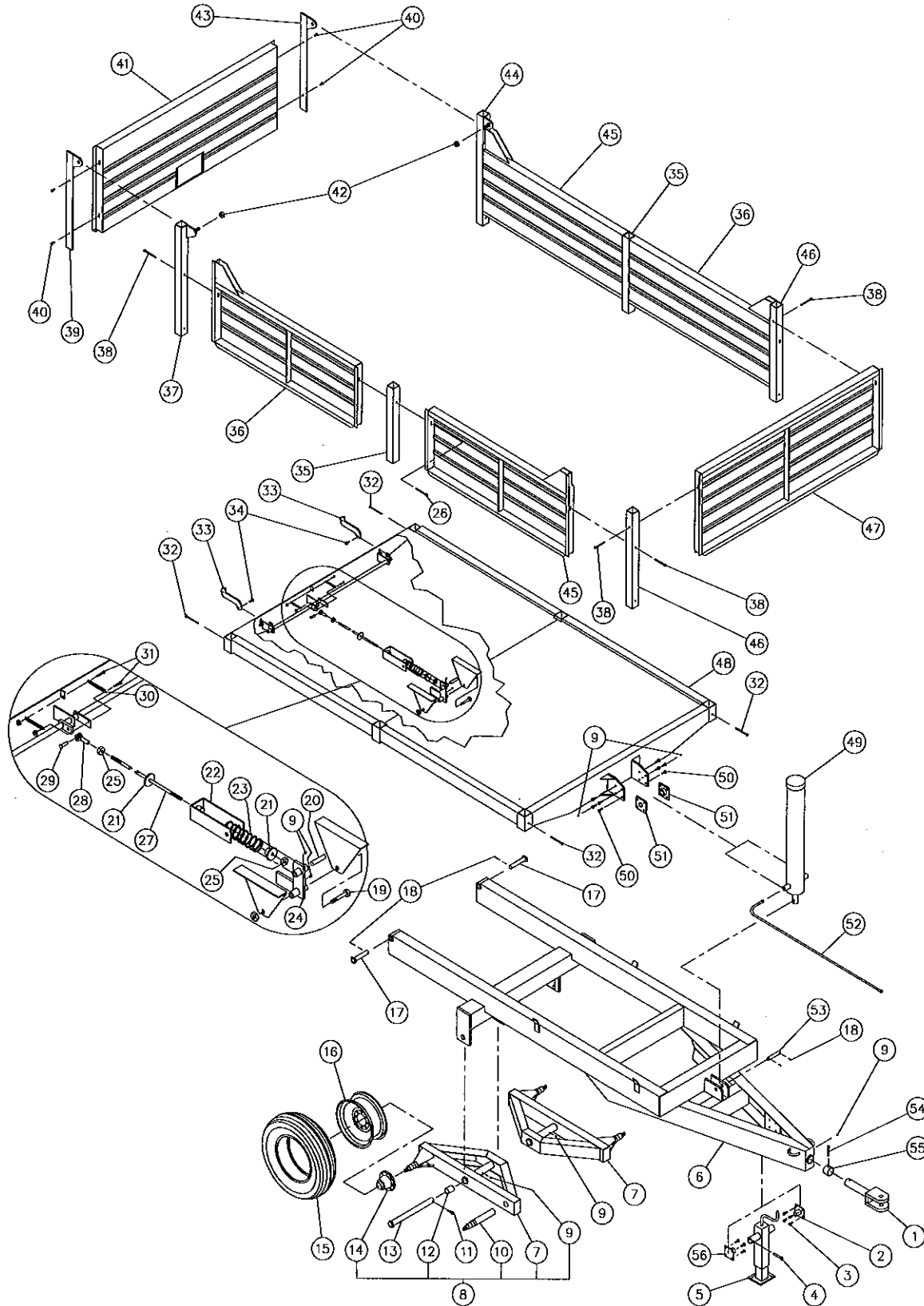

8

DUMP TRAILER P-524

REF.	PART #	DESCRIPTION	QTY
1	110-00491	Swivel hitch	1
2	110-00141	Jack fixation plate	1
3	Std.	Bolt 7/16" NC x 1 1/4" lg + nylon locknut	8
4	110-00191	Pin for jack	1
5	110-08851	Jack PC-3012 HD	1
6	120-01621	Frame	1
7	110-08861	Tandem frame	2
8	110-08871	Tandem assembly	2
9	Std.	Grease fitting 1/4"-28 straight	7
10	150-01801	Spindle 2 1/4" ø (welded)	4
11	Std.	Bolt 1/2" NC x 3" lg + nylon locknut	2
12	160-00661	Brass bushing 1 3/4" lg+ nylon locknut	4
13	110-00021	Tandem clevis pin 1 3/4" ø x 19 3/8" lg	2
14	10146	Complete hub assembly #5500 (8 bolts)	4
15	PN12.5L15	Tire 12.5L15	4
16	R-15108	Rim	4
17	110-08881	Clevis pin 1 1/4" ø x 6 3/4" lg	2
18	Std.	Cotter pin 3/16" x 2"	4
19	Std.	Bolt 3/4" NC x 5 1/2" lg + nylon locknut	1
20	150-01811	Clevis pin 3/4" ø x 3 1/4" lg	1
21	110-08891	Washer	1
22	110-08901	Spring holder	1
23	10201	Spring 7/16" x 1 3/4" i.d. x 2 5/8" o.d. x 7 1/2" lg	1
24	110-08911	Lock assembly pivot	1
25	339-40000	Nut 1/2" - 20 NF	2
26	Std.	Bolt 7/16" NC x 4 1/2" lg + nylon locknut +2 flat washers	2
27	110-08921	Rod 1/2" for rear panel lock	1
28	51435	Clevis yoke 1/2" - 20 NF	2
29	51436	Clevis pin 1/2" x 1 37/64" lg	1
30	Std.	Spring B-616	2
31	Std.	Bolt 5/16" NC x 1 1/2" lg + nylon locknut	2
32	Std.	Bolt 7/16" NC x 4 1/2" lg + nylon locknut	4
33	130-09981	Rear panel lock	2
34	Std.	Bolt 1/2" NC x 2" lg + nylon locknut	2
35	160-04701	Center stake	2
36	110-08932	Side panel	2
37	110-03821	Right rear stake	1
38	Std.	Bolt 7/16" NC x 4" lg + nylon locknut & flat washer	6
39	110-03812	Right attachment of the rear panel	1
40	Std.	Plow bolt 7/16" NC x 1 1/2" lg + nylon locknut & flat washer	4
41	120-01631	Rear panel with grain door	1
42	346-46000	Nylon locknut 3/4" NC PL	2
43	110-03811	Left attachment of the rear panel	1
44	110-03822	Left rear stake	1
45	110-08931	Side panel	2
46	160-04711	Front stake	2
47	110-08941	Front panel	1
48	120-01641	Platform	1
49	52013	Cylinder # 897	1
NI	52063	Seal kit for cylinder # 897, part 52013 above	1
50	Std.	Bolt 1/2" NC x 2" lg + nylon locknut	8
51	110-08951	Jack support plate	2
52	190-00701	Hose 1/2" x 80" lg + 2 fittings 8U-108	1
53	150-01821	Clevis pin 1" ø x 5 1/4" lg	1
54	Std.	Bolt 5/8" NC x 4" lg + nylon locknut	1
55	160-00821	Ring	1
56	110-00151	Jack fixation plate	1

8

HUB H5500 #10146

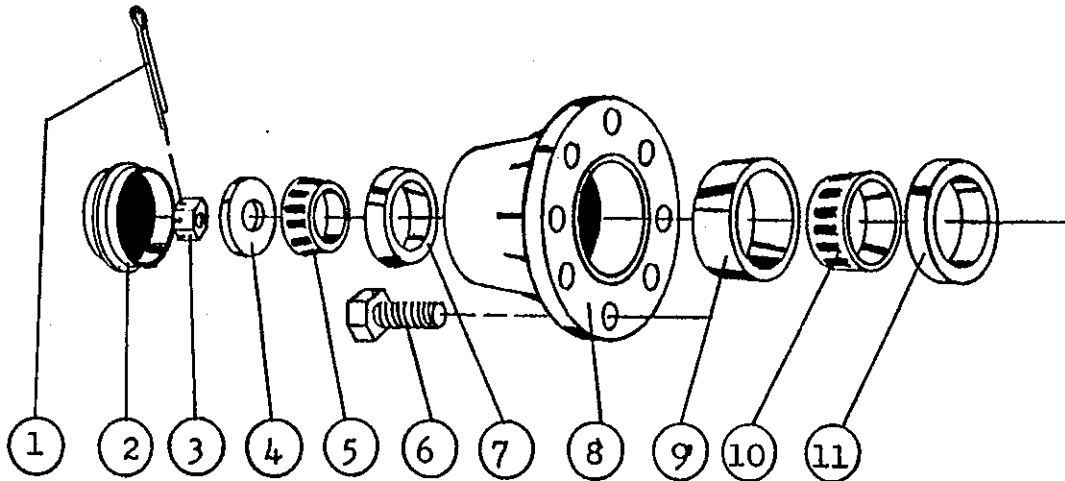

REF.	PART #	DESCRIPTION	QTY
1	Std.	Cotter pin 5/32" x 1 1/2"	1
2	51417	Dust cap 2.570" \varnothing	1
3	51442	Castle nut 7/8" NF	1
4	Std.	Flat washer 7/8" \varnothing	1
5	51416	Roller bearing: cone no. 4T-LM48548	1
6	51418	Rim screw 9/16"	8
7	51415	Roller bearing: cup no. 4T-LM48510	1
8	52062	Hub only H5500	1
9	51413	Roller bearing: cup no. 4T-LM603011	1
10	51412	Roller bearing: cone no. 4T-LM603049	1
11	51443	Oil seal no. CR20044	1

8

JACK PC-3012HD 110-01351

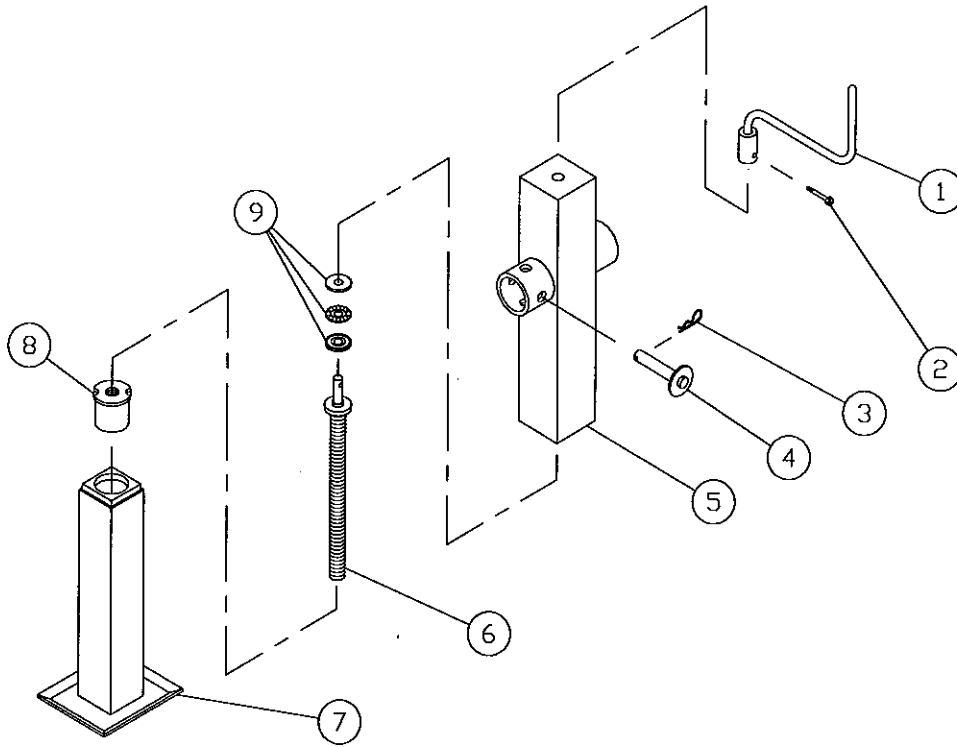







REF.	PART #	DESCRIPTION	QTY
1	110-00201	Hand crank	1
2	Std.	Bolt 1/4" NC x 1 1/2" lg + nylon locknut	1
3	Std.	Hitch pin clip 5/32"	1
4	110-00191	Pin 3/4" ø x 4" lg	1
5	110-00121	Jack external part	1
6	110-00101	Acme screw 7/8"-8 x 13 1/2" lg	1
7	110-00031	Jack support	1
8	160-00121	Acme nut 7/8"-8 x 1 7/8" lg (brass)	1
9	51475	Ball bearing	1





8

TORQUE CHART

TORQUE SPECIFICATION TABLE

Thread UNC and UNF		Grade 2 				Grade 5   				Grade 8*   			
Bolt size		Torque				Torque				Torque			
Inches	mm	Pound feet		Newton meters		Pound feet		Newton meters		Pound feet		Newton meters	
		min.	max.	min.	max.	min.	max.	min.	max.	min.	max.	min.	max.
1/4	6.35	5	6	6.8	8.13	9	11	12.2	14.9	12	15	16.3	30.3
5/16	7.94	10	12	13.6	16.3	17	20.5	23.1	27.8	24	29	32.5	39.3
3/8	9.53	20	23	27.1	31.2	35	42	47.5	57.0	45	54	61.0	73.2
7/16	11.11	30	35	40.7	47.4	54	64	73.2	86.8	70	84	94.9	113.9
1/2	12.70	45	52	61.0	70.5	80	96	108.5	130.2	110	132	149.2	179.0
9/16	14.29	65	75	88.1	101.6	110	132	149.2	179.0	160	192	217.0	260.4
5/8	15.88	95	105	128.7	142.3	150	180	203.4	244.1	220	264	298.3	358.0
3/4	19.05	150	185	203.3	250.7	270	324	366.1	439.3	380	456	515.3	618.3
7/8	22.23	160	200	216.8	271.0	400	480	542.4	650.9	600	720	813.6	976.3
1	25.40	250	300	338.8	406.5	580	696	786.5	943.8	900	1080	1220.4	1464.5
1 1/8	25.58	-	-	-	-	800	880	1084.8	1193.3	1280	1440	1735.7	1952.6
1 1/4	31.75	-	-	-	-	1120	1240	1518.7	1681.4	1820	2000	2467.9	2712.0
1 3/8	34.93	-	-	-	-	1460	1680	1979.8	2278.1	2380	2720	3227.3	3688.3
1 1/2	38.10	-	-	-	-	1940	2200	2630.6	2983.2	3160	3560	4285.0	4827.4

* Thick nuts must be used with grade 8 bolts.

Size of screw	Thread	Pitch (mm)	Grade 4T  				Grade 7T 				Grade 8T  			
			Torque				Torque				Torque			
			Pound feet		Newton meters		Pound feet		Newton meters		Pound feet		Newton meters	
		min.	max.	min.	max.	min.	max.	min.	max.	min.	max.	min.	max.	
M6	UNC	1.00	3.6	5.8	4.9	7.9	5.8	9.4	7.9	12.7	7.2	10	9.8	13.6
M8	UNC	1.25	7.2	14	9.8	19	17	22	23	29.8	20	26	27.1	35.2
M10	UNC	1.5	20	25	27.1	33.9	34	40	46.1	54.2	38	46	51.5	62.3
M12	UNC	1.75	28	34	37.9	46.1	51	59	69.1	79.9	57	66	77.2	89.4
M14	UNC	2.0	49	56	66.4	75.9	81	93	109.8	126	96	109	130.1	147.7
M16	UNC	2.0	67	77	90.8	104.3	116	130	157.2	176.2	129	145	174.8	196.5
M18	UNC	2.0	88	100	119.2	136	150	168	203.3	227.6	175	194	237.1	262.9
M20	UNC	2.5	108	130	146.3	176.2	186	205	252	277.8	213	249	288.6	337.4
M8	UNF	1.0	12	17	16.3	23	19	27	25.7	36.6	22	31	29.8	42
M10	UNF	1.25	20	29	27.1	39.3	35	47	47.4	63.7	40	52	54.2	70.5
M12	UNF	1.25	31	41	42	55.6	56	68	75.9	92.1	62	75	84	101.6
M14	UNF	1.5	52	64	70.5	86.7	90	106	122	143.6	107	124	145	168
M16	UNF	1.5	69	83	93.5	112.5	120	138	162.6	187	140	158	189.7	214.1
M18	UNF	1.5	100	117	136	158.5	177	199	239.8	269.6	202	231	273.7	313
M20	UNF	1.5	132	150	178.9	203.3	206	242	279.1	327.9	246	289	333.3	391.6

Use the above torques when special torque is not given.

NOTE: These values apply to fasteners as received from supplier, dry, or when lubricated with normal engine oil. They do not apply if extreme pressure lubricants are used.

WARRANTY

PRONOVOST warrants this product to the initial purchaser for the period of one year from the date of purchase against defects in materials and workmanship.

We will replace or repair defective parts free of charge if they are returned to our plant in St-Tite, Quebec, Canada.

Transportation charges are the responsibility of the customer. This warranty is not transferable.

Hydraulic cylinders are covered by the manufacturer of these items.

All PRONOVOST spare parts purchased are covered by a three (3) month warranty.

This warranty becomes void and nul if the equipment is modified, breaks down as the result of an accident, is not operated according to manufacturer's recommendations, damaged by negligence or if maintenance has not been carried out as specified.

Our obligation is limited to the replacement or repair of the defective part. PRONOVOST accepts no responsibility for direct or indirect consequential damages of any kind.

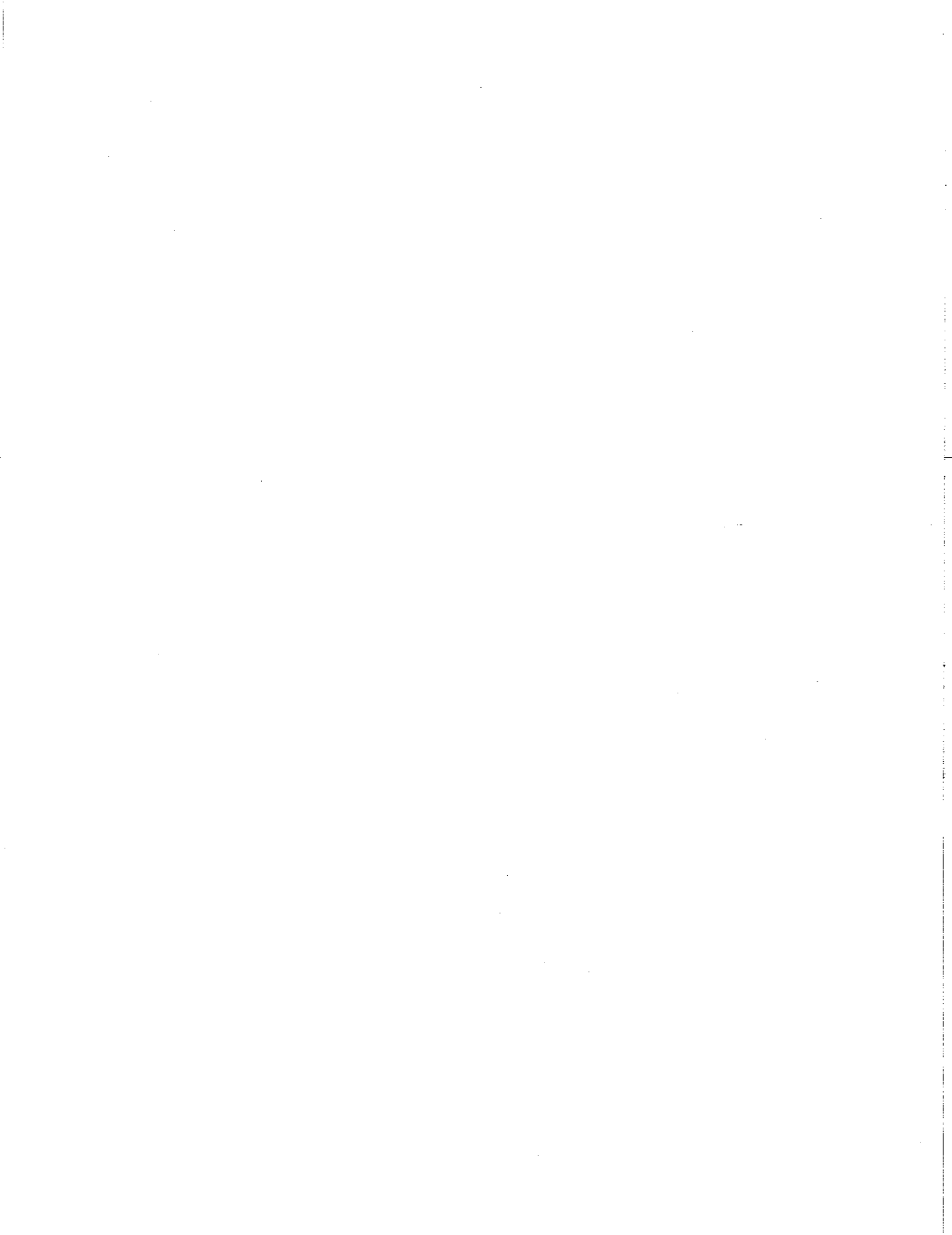

Ce manuel est aussi disponible en français.
Veuillez téléphoner.



LES MACHINERIES PRONOVOST INC.
260, route 159,
Saint-Tite, Quebec, Canada, G0X 3H0
Tel.: (418) 365-7551, Fax: (418) 365-7954