



**OPERATOR'S / PARTS
MANUAL**



Dump trailers

Models

P-508/3S

P-510/3S

P-50710/4E

VISIT OUR WEBSITE



www.pronovost.qc.ca

Copyright © Les Machineries Pronovost Inc., 2007

All rights reserved.
Printed in Canada.

TABLE OF CONTENTS

Section	Item	Page
1	Introduction	5
2	Safety	6
	General Safety	6
	Safety in Operation	6
	Safety with Maintenance	7
	Safety in Transport	7
3	Decals	8
	Safety Decals	8
	Maintenance Decals	8
4	Start-up	9
	Basic Start-up Procedures	9
5	Maintenance	11
6	Storage	12
7	Specifications	13
8	Parts List	14
	Dump Trailer P-508/3S	14
	Dump Trailers P-510/3S	17
	Dump Trailer P-50710/4E	20
	Electric Hydraulic Pump P-510-PHEP	23
	Electric circuit	24
	Hub H4000	25
	Hub H5000	26
	Hub and drum 545, electric brakes 10 x 2 ¹ / ₄ "	27
	Directional Control Valve DFC40	28
	Telescopic Cylinder # 51506	29
	Power Pack # 51624	30
9	Torque Chart	32
10	Warranty	33

INTRODUCTION

1

CONGRATULATIONS!

Thank you for choosing PRONOVOST. We are confident this equipment will meet your requirements in terms of quality, performance and reliability.

This manual was prepared to assist you in the safe operation of your new Dump Trailer. It contains important information which will help you achieve excellent returns with your PRONOVOST Dump Trailer for years to come.

Please read this manual before operating your Trailer and keep it for future reference.

Before using this equipment, you or any other person who will be using it must familiarize yourself with the safety recommendations, the operating and safety instructions. Please read carefully and be sure to understand and follow all recommendations and procedures.

In this manual, the right and left sides are identified while standing at the rear end of the equipment and facing it.

If you require additional information on your Dump Trailer, please contact your PRONOVOST Dealer.

NOW take a moment to enter the model, serial number and the date of purchase of your Trailer in the space provided below.

When ordering parts from your Dealer, please refer to these numbers for a fast and efficient service. Use PRONOVOST parts for replacement.

The model and serial numbers are on the name plate shown on Fig. 1.

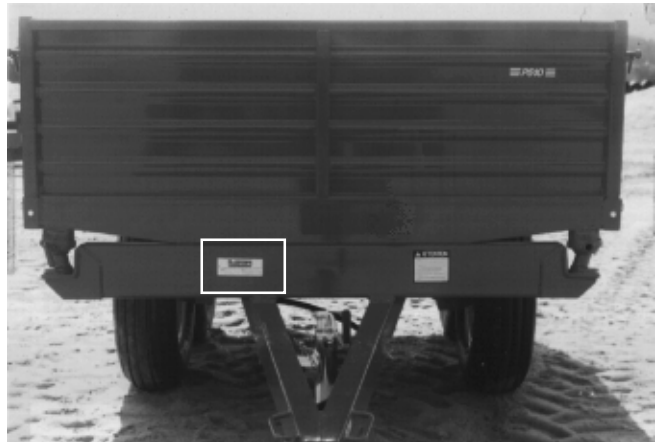

Figure 1

MODEL: _____ ✍

SERIAL NO: _____ ✍

DATE OF PURCHASE: _____ ✍

SAFETY

GENERAL SAFETY

2

WHEN YOU SEE THIS SYMBOL



ATTENTION!

**BE ALERT
YOUR SAFETY IS INVOLVED**

This symbol "**SAFETY ALERT**" is used in this manual and on the safety decals on the Trailer. It warns you of the possibility of danger. Carefully read, understand and follow all safety recommendations before operating the equipment.

- 1) Careful operation is the best assurance against accidents. Carefully read this manual and follow all recommendations before operating this equipment. It is the owner's responsibility to make sure that anyone who will operate the Trailer will read this manual before operating the equipment.
- 2) Do not modify the equipment. Any non authorized modification may affect the efficiency and/or safety of the equipment.
- 3) Never operate the equipment with defective parts or if damaged in any way. Have it repaired before using it.
- 4) Make sure all fasteners are in place and properly secured or tightened. Refer to torque chart on page 32.
- 5) Hydraulic fluids under pressure can damage your skin. Do not use your hands to locate a leak.
- 6) Battery (with 12V hydraulic system) contains

sulfuric acid. Avoid contact with skin, eyes or clothing.

SAFETY IN OPERATION

- 1) **WARNING!** Do not overload your trailer, do not exceed the load capacity indicated in the specifications on page 13.
- 2) Be sure there are no obstructions around the equipment and that no one stands near the equipment when in use.
- 3) Do not operate an engine in a confined or non ventilated area.
- 4) Do not perform any adjustments, cleaning, maintenance or repairs with the engine running on the towing vehicle. Preferably remove the key from the ignition.
- 5) Be careful when backing-up, make sure you have good visibility.
- 6) In the case of a Highway Service Trailer, make sure the suspension, brakes and lights are all functioning properly.
- 7) Do not forget to unlock the proper panel before dumping.
- 8) With the 3-way dump trailers, do not forget to install the pins in the two ball-joints on the side you wish to dump the load, and release the adjacent panel.
- 9) Always travel at a safe operating speed following regulations and common sense. In the case of agricultural service tires, follow the manufacturer's specified safe speed. The road speed should be such as to maintain full control over steering and braking.

SAFETY (cont'd)

SAFETY WITH MAINTENANCE

- 1) Perform maintenance according to recommendations contained in this manual.
 - 2) **Before performing any work under the raised platform, always install the safety support provided.**
 - 3) If the trailer is hooked up to the tractor while performing maintenance work, make sure the engine is not running and preferably remove the ignition key.
- 2) Be alert while driving on the road. Never carry passengers.

2

SAFETY IN TRANSPORT

- 1) On public roads, use proper safety lights and check local regulations.

DECALS

SAFETY DECALS

The safety decals are affixed wherever special safety precautions are indicated. Locate them on the equipment and read them carefully. If a decal is damaged, lost or illegible, install a new one. The following photos indicate where each one must be installed.

3

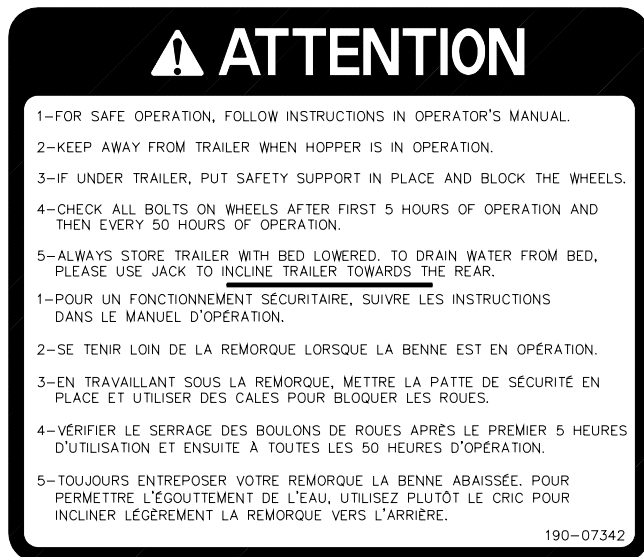

Figure 2

Decal A

Part no.: 190-07342

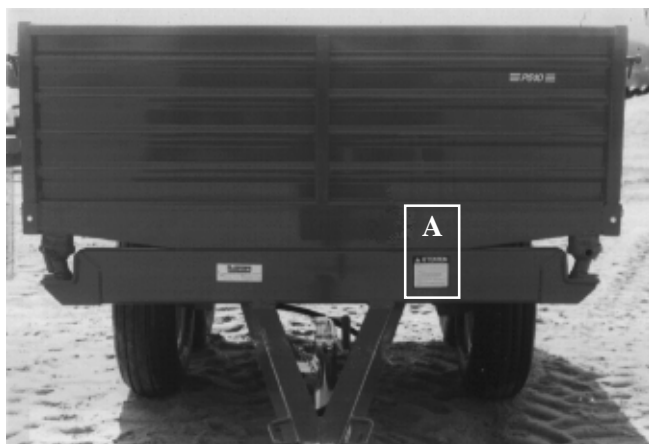

Figure 3

MAINTENANCE DECALS

The maintenance decals indicate the points requiring lubrication. Refer to maintenance section for more details.

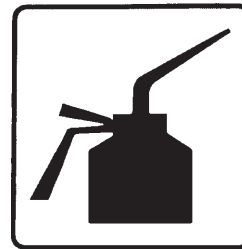

Figure 4

Part no.: A 105



Figure 5

Part no.: A 106

START-UP

BASIC START-UP PROCEDURES

- 1) Lubricate all grease fittings with a good quality multiuse grease.
- 2) Lubricate panel release mechanism, front and rear with good quality oil.
- 3) Adjust tire pressure to manufacturer's specifications.
- 4) Install wheels on hubs.

! WARNING: Wheel lug nuts must be applied and maintained at the proper torque levels to prevent loose wheels, broken studs, and possible separation of the wheel(s) from your trailer. The lug nuts on the wheels of your trailer must be maintained according to the torque values listed in the chart contained in this section. Over torquing and under torquing wheels are both dangerous.

! WARNING: Towing, especially during the break-in period, can cause wheel lug nuts to loosen. Failure to maintain proper torque of the wheel lug nuts could lead to separation of the tire and wheel while driving, possibly resulting in property damage or personal injury.

Be sure to use only lug nuts matched to the cone angle of your wheel, usually 60° or 90°.

The proper procedure and sequence for attaching the wheels and torquing lug nuts is as follows.

- a- Start all nuts by hand to avoid cross threading.
- b- Tighten the nuts slightly.
- c- Using the proper sequence shown in figure 6, tighten the lug nuts to the 1st stage torque as

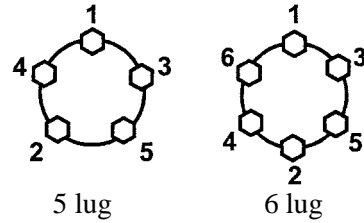

Figure 6

indicated in the chart. Using the proper sequence for the second time, tighten the lug nuts to the 2nd stage torque as indicated in the chart. Using the proper sequence for the third time, tighten the lug nuts to the 3rd stage torque as indicated in the chart.

4

Wheel Torque Requirements			
Nut Ø	1 st Stage	2 nd Stage	3 rd Stage
1/2"	20 - 25 ft-lbs	35 - 40 ft-lbs	50 - 75 ft-lbs
9/16"	20 - 25 ft-lbs	50 - 60 ft-lbs	90 - 120 ft-lbs
5/8"	20 - 25 ft-lbs	90 - 100 ft-lbs	140 - 170 ft-lbs

d- Torque the wheel lug nuts before the first road use and after each wheel removal. Check and re-torque after the first 16, 40 and 80 kilometers (10, 25 and 50 miles) and adjust if required. Check periodically thereafter without exceeding 50 hours of use between the verifications.

Check the wheel lugs after winter storage, before starting a trip or following extensive braking. Perform maintenance periodically as indicated above.

- 5) Install panels.
- 6) Install all hydraulic hoses and fittings compatible with your equipment.

START-UP

- 7) Verify for adequate tightness of all fastening devices. Refer to torque chart on page 32.
- 8) Operate the hydraulic system a few times, raising and lowering the platform in order to remove any trapped air in the system. Then check the oil level in the tractor's hydraulic oil reservoir.
- 9) With the 3-way dump trailer, the ball-joint pins are usually installed in a "X" configuration to prevent tipping during handling. They must be installed on the side you wish to dump the load. **ATTENTION: Never use the "X" configuration when using your Dump Trailer.**
- 10) Do not forget to unlock the proper panel before dumping.

4

MAINTENANCE

Before performing any work under the raised platform, always install the safety support provided.

- 1) Wipe off all grease fittings with a clean cloth before adding grease in order to avoid injecting dirt or sand.
- 2) Repair or replace damaged grease fittings.
- 3) Lubricate all grease fittings every 20 hours of operation.
- 4) Check all bolts on wheels as indicated in the start-up section.
- 5) Lubricate panel release mechanism, front and rear, every 20 hours of operation.
- 6) Check tire pressure every 50 hours of operation, adjust according to manufacturer's recommendation indicated on the tires.
- 7) Check brakes once a year and adjust or repair if necessary.

- 8) Open, clean and lubricate wheel bearings once a year.

Adjust the bearings as follows:

- a- Lubricate spindle threads.
- b- Screw the adjusting nut on the spindle thread.
- c- Set a bearing preloading by torquing the adjusting nut to 200 ft-lbs to make up for any play between parts. **N.B.: This step must be carried out while rotating the wheel.**
- d- Loosen the adjusting nut one complete turn.
- e- Now tighten it again to a 50 ft-lbs torque.
- f- Loosen the nut 1/4 turn; while doing so, determine the right position for the locking device.
- g- Install the locking device.

- 9) Check all nuts and bolts once a year. If necessary use torque chart on page 32.

5

STORAGE

- 1) Store in a cool, dry place.
- 2) Install wooden blocks under the axles to keep the tires off the ground and cover them if left exposed to the sun.
- 3) Keep all piston rods in the retracted position. This will assure better protection against the elements.
- 4) Clean your trailer.
- 5) Thoroughly inspect all parts of the trailer. Replace or repair worn or defective parts.
- 6) Touch-up or repaint if necessary.
- 7) Lubricate all points before storage.

SPECIFICATIONS

SERVICE	AGRICULTURAL	AGRICULTURAL	HIGHWAY
MODEL	P-508/3S	P-510/3S	P-50710/4E
Gross weight	4 tons	5 tons	3.5 tons
Width x length interior of box	62" x 99"	62" x 99"	62" x 99"
Thickness of floor	3/16"	3/16"	3/16"
Side panel height 12G *	14"	14"	14"
Front/back panel height 12G *	19"	19"	19"
Platform height	33"	33"	35"
Overall length	138"	138"	138"
Overall width	68"	68"	68"
Overall height	63"	63"	65"
Free height / maximum lift	20"	20"	22"
Thread width	51"	51"	52 1/2"
Dumping angle (back)	47°	47°	47°
Dumping angle (2 sides)	47°	47°	47°
Central unloading hatch	option	option	option
Axle	Single	Tandem	Tandem
Suspension	--	--	Springs
Hubs	6 bolts	6 bolts	5 bolts
Hub capacity	5000 lbs	4000 lbs	1750 lbs
Spindles	2 1/4"	2"	--
Wheels	2	4	4
Wheel dimensions	15 x 8 x 6	15 x 8 x 6	14" x 6"
Tires (standard)	11L15 (8 ply)	11L15 (8 ply)	ST205/75R14
Hitch: clevis/swivel	standard	standard	option
Hitch: ball coupler (2 5/16")	option	option	standard
Electric brakes	--	--	standard
Security chain	option	option	standard
Electric power pack	option	option	option
Battery rack	option	option	standard
Light system (12 V)	--	--	standard
Oil / volume required	5 L	5 L	5 L
Cylinder	1 single acting	1 single acting	1 single acting
Hitch weight (empty)	125 lbs	125 lbs	125 lbs
Total weight	1775 lbs	1850 lbs	1850 lbs

Design and specifications subject to change without notice.

* Removable

DUMP TRAILER P-508/3S

170-02305R1

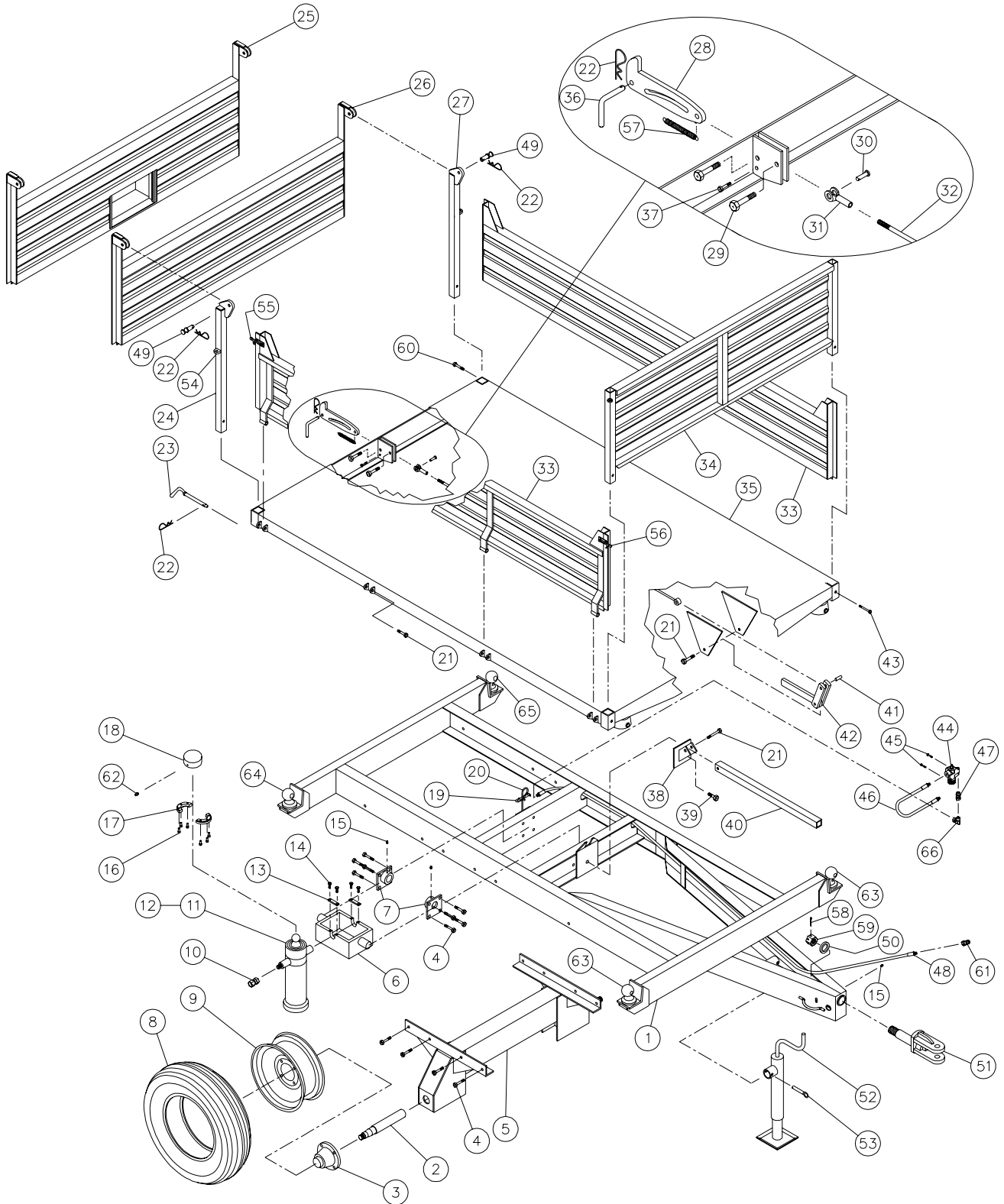

8

DUMP TRAILER P-508/3S (cont'd)

REF.	PART #	DESCRIPTION	QTY
1	120-02233	Frame	1
2	150-00312	Axle 2 1/4" ø (welded)	2
3	51441	Hub # H-5000 complete	2
4	300-40310	Bolt 1/2" NC x 1 1/2" lg + nylon locknut	16
5	110-08962	Cross-beam (including # 2)	1
6	51610	Cylinder gimbal	1
7	110-09041	Pivot plate	2
8	PN-11L15	Tire 11L15 - 8 ply with tube	2
9	R-1586	Rim 15" x 8" - 6 holes	2
10	9255-8x8	Straight fitting (swivel)	1
11	51506	Telescopic cylinder 3 sections	1
12	51527	Repair kit for cylinder no. 51506	1
13	51572	Retaining plate for cylinder gimbal	2
14	51573	Metric bolt 8 x 20 x 1.25 mm	4
15	Std.	Grease fitting 1/4" - 28 straight	3
16	51574	Retaining ring 2 5/8" int. (up to serial # 8799)	1
16	331-13220	Hex socket cap screw M8-1.25mm x 20mm (from serial # 8800 and up)	6
17	51575	Locking segments for ball-joint 2 7/8" (up to serial # 8799)	2
17	51620	Locking segments for ball-joint (from serial # 8800 and up)	2
18	51576	Ball joint seat (welded) 4 1/2" (up to serial # 8799)	1
18	51619	Ball-joint seat (welded) (from serial # 8800 and up)	1
19	Std.	Cable clamp 3/16"	2
20	190-03031	Cable 3/16" x 72"	1
21	300-40400	Bolt 1/2" NC x 3" lg + nylon locknut	10
22	Std.	Hitch pin clip 5/32"	5
23	150-00721	Pin for platform pivot	2
24	110-14391	Right rear stake	1
25	120-00522	Rear panel with grain door	opt.
26	110-02772	Standard rear panel	1
27	110-14461	Left rear stake	1
28	130-16212	Rear panel lock	1
29	300-40340	Bolt 1/2" NC x 2" lg + nylon locknut	2
30	51436	Pin 1/2" ø x 1 3/4" lg	1
31	51435	Clevis 1/2" - 20 NF + nut	1
32	110-14542	Rod 1/2" for rear panel lock	1
33	110-11541	Side panel	2
34	110-11532	Front panel	1
35	120-01654	Platform	1
36	150-02861	Pin for rear locking mechanism	1
37	300-34325	Bolt 5/16" NC x 1 3/4" lg + nylon locknut	1
38	110-11561	Safety support bracket	1
39	300-44310	Bolt 5/8" NC x 1 1/2" lg + nylon locknut	1
40	160-05971	Safety support	1
41	150-02761	Pin 1/2" x 1 1/2" lg	1
42	110-14271	Lever for automatic locking mechanism	1
43	300-36370	Bolt 3/8" NC x 2 1/2" lg + nylon locknut	2
44	644-10000	Directional control valve 3/8" NPT (cyl. travel limit)	1
44	51632	Directional control valve 3/8" NPT (ser.# 9186 and 9299 to 9323)	1
45	300-34250	Bolt 5/16" NC x 1" lg + nut & lock washer	2
46	190-03042	Hose R1 3/8" x 34" lg + 1 fitting 6U 106 & 1 fitting 6U 108	1



DUMP TRAILER P-508/3S (cont'd)

REF.	PART #	DESCRIPTION	QTY
47	9205x6x6	Straight fitting 3/8" NPT	1
48	190-03052	Hose R1 3/8" x 150" lg + 1 fitting 6U 106 & 1 fitting 6U 108	1
49	150-02851	Hinge pin for rear panel	2
50	130-20331	Flat washer 1 5/8" i.d. x 2 1/4" o.d.	1
51	110-08991	Swivel hitch	1
52	51490	Jack 3000 lbs (includes # 53)	1
53	51408	Pin for jack	1
54	51583	Ring for side panel lock (welded)	4
55	51584-G	Side panel lock (L.H.) (welded)	2
56	51584-D	Side panel lock (R.H.) (welded)	2
57	190-08211	Spring 7/8" o.d. x 6 1/8"	1
58	Std.	Cotter pin 1/4" x 3"	1
59	357-57000	Castle nut 1 1/2" NC	1
60	300-36370	Bolt 3/8" NC x 2 1/2" lg	2
61	Std.	Quick coupler 1/2" male	1
62	Std.	Grease fitting 1/4"-28, 45 deg.	1
63	51621	Front ball-joint (welded)	2
64	51622	Right hand rear ball-joint (welded)	1
65	51623	Left hand rear ball-joint (welded)	1
66	9405x6x6	Elbow 90 deg. 3/8" NPT	1

DUMP TRAILER P-510/3S

170-02317R1

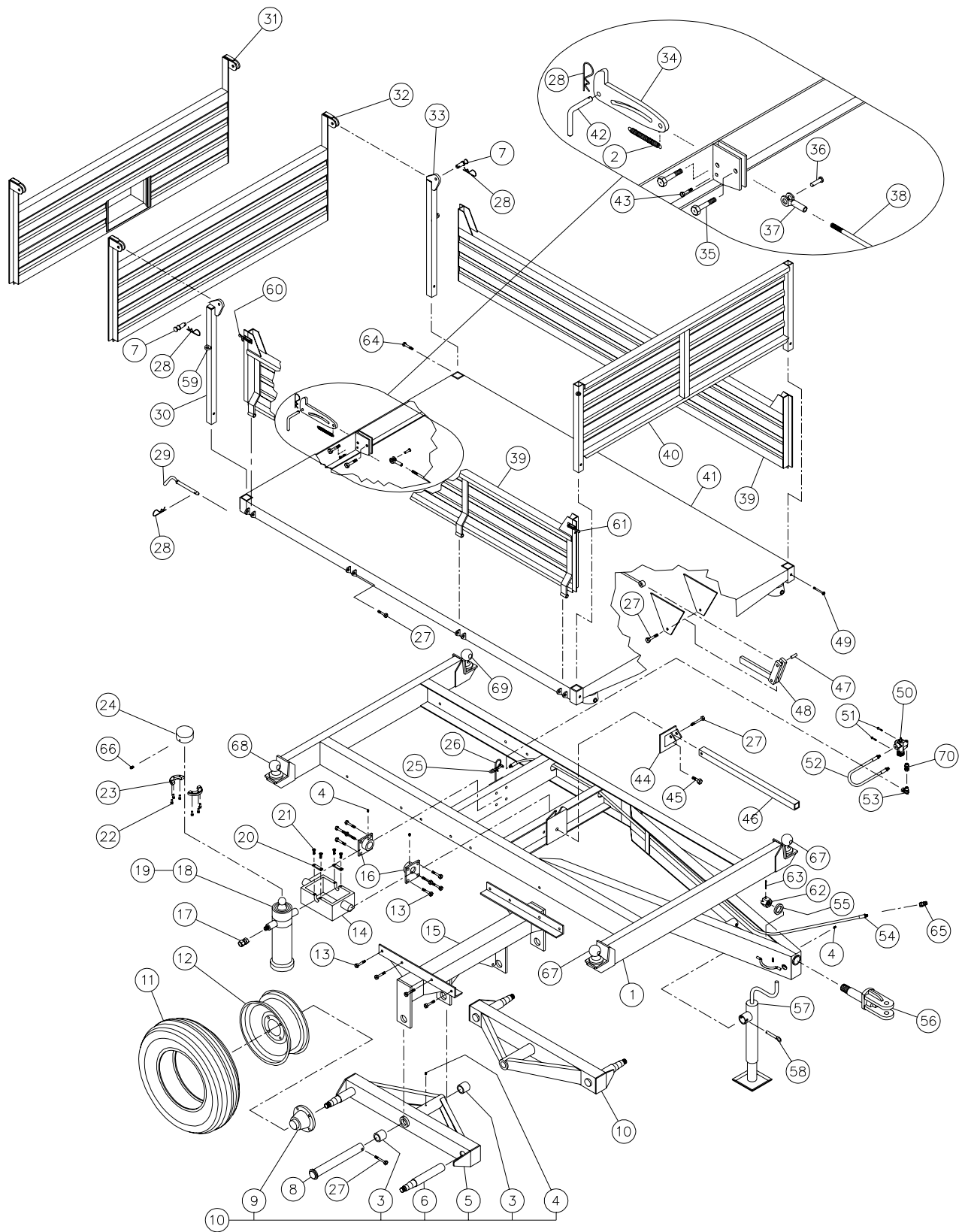

8

DUMP TRAILER P-510/3S (cont'd)

REF.	PART #	DESCRIPTION	QTY
1	120-02233	Frame	1
2	190-08211	Spring 7/8" d.e. x 6 1/8" lg	1
3	160-01091	Brass bushing 1 3/4" i.d. x 2" o.d. x 2" lg	4
4	Std.	Grease fitting 1/4"-28 straight	5
5	110-11412	Tandem frame	2
6	150-02282	Axle 2" ø (welded)	4
7	150-02851	Hinge pin for rear panel	2
8	110-00011	Pin for tandem	2
9	51503	Hub # H-4000 complete	4
10	110-11414	Tandem assembly (including 3, 4, 5, 6 & 9)	2
11	PN-11L15	Tire 11L15 - 8 ply	4
12	R-1586	Rim 15" x 8" - 6 holes	4
13	300-40310	Bolt 1/2" NC x 1 1/2" lg + nylon locknut	16
14	51610	Cylinder gimbal	1
15	110-11421	Cross-beam	1
16	110-09041	Pivot plate	2
17	9255-8x8	Straight fitting (swivel)	1
18	51506	Telescopic cylinder 3 sections	1
19	51527	Repair kit for cylinder no. 51506	1
20	51572	Retaining plate for cylinder gimbal	2
21	51573	Metric bolt 8 x 20 x 1.25 mm	4
22	51574	Retaining ring (up to serial # 8799)	1
22	331-13220	Hex socket cap screw M8-1.25mm x 20mm (from serial # 8800 and up)	6
23	51575	Locking segments for ball-joint (up to serial # 8799)	2
23	51620	Locking segments for ball-joint (from serial # 8800 and up)	2
24	51576	Ball-joint seat (welded) (up to serial # 8799)	1
24	51619	Ball-joint seat (welded) (from serial # 8800 and up)	1
25	Std.	Cable clamp 3/16"	2
26	190-03031	Cable 3/16" x 72"	1
27	300-40400	Bolt 1/2" NC x 3" lg + nylon locknut	12
28	Std.	Hitch pin clip 5/32"	5
29	150-00721	Pin for platform pivot	2
30	110-14391	Right rear stake	1
31	120-00522	Rear panel with grain door	opt.
32	110-02772	Standard rear panel	1
33	110-14461	Left rear stake	1
34	130-16212	Rear panel lock	1
35	300-40340	Bolt 1/2" NC x 2" lg + nylon locknut	2
36	51436	Pin 1/2" ø x 1 3/4" lg	1
37	51435	Clevis 1/2" - 20 NF + nut	1
38	110-14542	Rod 1/2" for rear panel lock	1
39	110-11541	Side panel	2
40	110-11532	Front panel	1
41	120-01654	Platform	1
42	150-02861	Pin for rear locking mechanism	1
43	300-34325	Bolt 5/16" NC x 1 3/4" lg + nylon locknut	1
44	110-11561	Safety support bracket	1
45	300-44310	Bolt 5/8" NC x 1 1/2" lg + nylon locknut	1
46	160-05971	Safety support	1
47	150-02761	Pin 1/2" x 1 1/2" lg	1

DUMP TRAILER P-510/3S (cont'd)

REF.	PART #	DESCRIPTION	QTY
48	110-14271	Lever for automatic locking mechanism	1
49	300-36370	Bolt 3/8" NC x 2½" lg + nylon locknut	2
50	644-10000	Directional control valve 3/8" NPT (cyl. travel limit)	1
50	51632	Directional control valve 3/8" NPT (serial # 9186 and from 9299 to 9323)	1
51	300-34250	Bolt 5/16" NC x 1" lg + nylon locknut	2
52	190-03042	Hose R1 3/8" x 34" lg + 1 fitting 6U 106 & 1 fitting 6U 108	1
53	9405-6x6	Elbow 90 deg. 3/8" NPT	1
54	190-03052	Hose R1 3/8" x 150" lg + 1 fitting 6U 106 & 1 fitting 6U 108	1
55	130-20331	Flat washer 1 5/8" i.d. x 2 1/4" o.d.	1
56	110-08991	Swivel hitch	1
57	51490	Jack 3000 lbs (includes # 58)	1
58	51408	Pin for jack	1
59	51583	Ring for side panel lock (welded)	4
60	51584-G	Side panel lock (L.H.) (welded)	2
61	51584-D	Side panel lock (R.H.) (welded)	2
62	Std.	Castle nut 1 1/2" NC	1
63	Std.	Cotter pin 1/4" x 3" lg	1
64	300-36370	Bolt 3/8" NC x 2 1/2" lg	2
65	Std.	Quick coupler 1/2" male	1
66	Std.	Grease fitting 1/4"-28, 45 deg.	1
67	51621	Front ball-joint (welded)	2
68	51622	Right hand rear ball-joint (welded)	1
69	51623	Left hand rear ball-joint (welded)	1
70	9205x6x6	Fitting straight 3/8" NPT	1

DUMP TRAILER P-50710/4E

170-02329R1

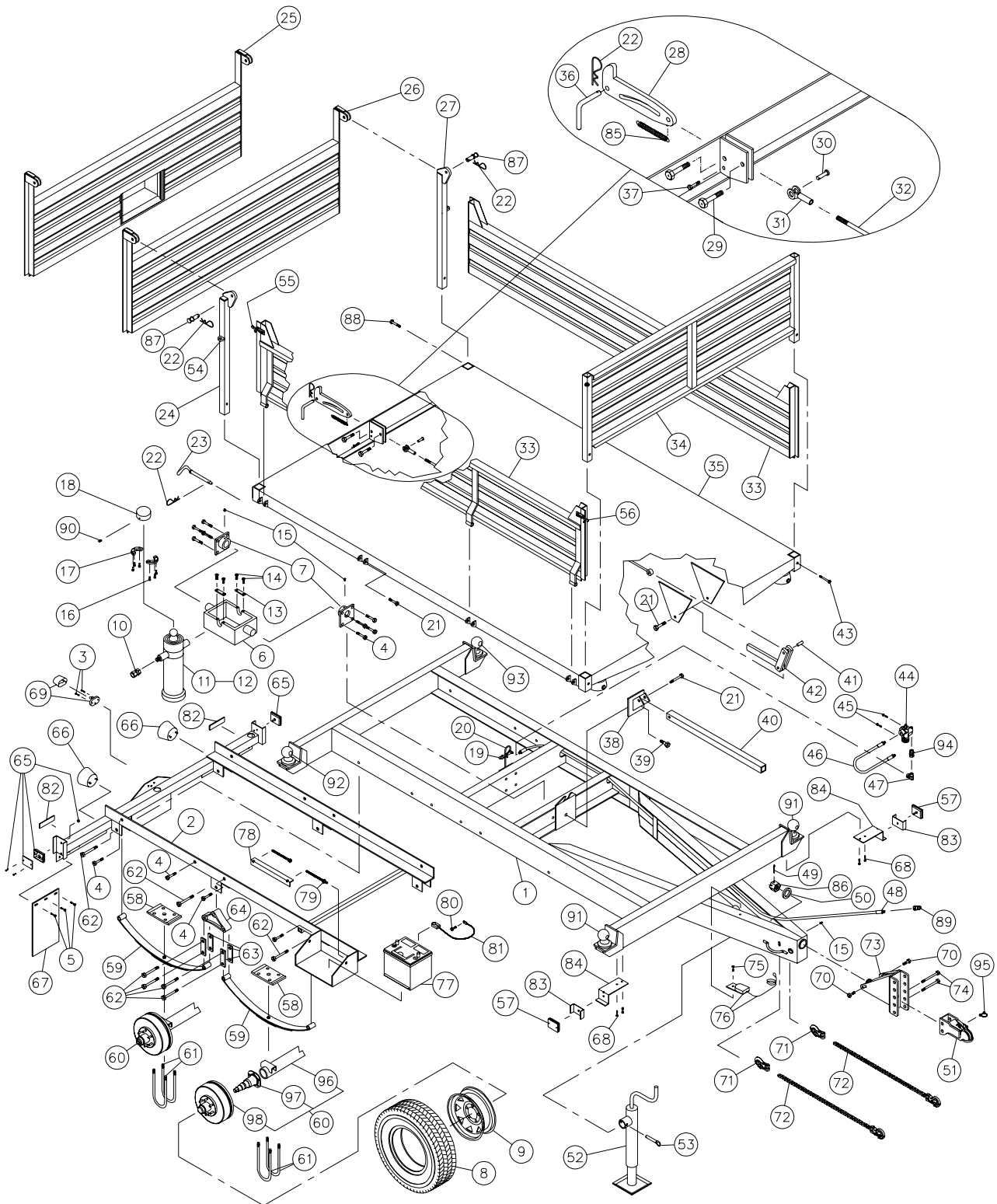

8

DUMP TRAILER P-50710/4E (cont'd)

REF.	PART #	DESCRIPTION	QTY
1	120-02233	Main frame for P-50710/4E	1
2	120-02372	Frame to fasten road axle and lights	1
3	300-20250	Bolt 10-24 x 1" lg + nylon locknut	2
4	300-40310	Bolt 1/2" NC x 1 1/2" lg + nylon locknut	16
5	300-32250	Bolt 1/4" NC x 1" lg + nylon locknut + flat washer	6
6	51610	Cylinder gimbal	1
7	110-09041	Pivot plate	2
8	PN-2057514	Road tire P205/75R14	4
9	RM1465	Rim 14 x 6 - 5 bolts	4
10	9255-8x8	Straight fitting (swivel)	1
11	51506	Telescopic cylinder 3 sections	1
12	51527	Repair kit for cylinder no. 51506	1
13	51572	Retaining plate for cylinder gimbal	2
14	51573	Metric bolt 8 x 20 x 1.25 mm	4
15	Std.	Grease fitting 1/4" - 28 straight	3
16	51574	Retaining ring 2 5/8" int. (up to serial # 8799)	1
16	331-13220	Hex socket cap screw M8-1.25mm x 20mm (from serial # 8800 and up)	6
17	51575	Locking segments for ball-joint 2 7/8" (up to serial # 8799)	2
17	51620	Locking segments for ball-joint (from serial # 8800 and up)	2
18	51576	Ball-joint seat (welded) 4 1/2" (up to serial # 8799)	1
18	51619	Ball-joint seat (welded) (from serial # 8800 and up)	1
19	Std.	Cable clamp 3/16"	2
20	190-03031	Cable 3/16" x 72"	1
21	300-40400	Bolt 1/2" NC x 3" lg + nylon locknut	10
22	Std.	Hitch pin clip 5/32"	5
23	150-00721	Pin for platform pivot	2
24	110-14391	Right rear stake	1
25	120-00522	Rear panel with grain door	opt.
26	110-02772	Standard rear panel	1
27	110-14461	Left rear stake	1
28	130-16212	Rear panel lock	1
29	300-40340	Bolt 1/2" NC x 2" lg + nylon locknut	2
30	51436	Pin 1/2" ø x 1 3/4" lg	1
31	51435	Clevis 1/2" NF + nut	1
32	110-14542	Rod 1/2" for rear panel lock	1
33	110-11541	Side panel	2
34	110-11532	Front panel	1
35	120-01654	Platform	1
36	150-02861	Pin for rear locking mechanism	1
37	300-34325	Bolt 5/16" NC x 1 3/4" lg + nylon locknut	1
38	110-11561	Safety support bracket	1
39	300-44310	Bolt 5/8" NC x 1 1/2" lg + nylon locknut	1
40	160-05971	Safety support	1
41	150-02761	Pin 1/2" x 1 1/2" lg	1
42	110-14271	Lever for automatic locking mechanism	1
43	300-36370	Bolt 3/8" NC x 2 1/2" lg + nylon locknut	2
44	644-10000	Directional control valve 3/8" NPT (cyl. travel limit)	1
44	51632	Directional control valve 3/8" NPT (serial # 9186 and from 9299 to 9323)	1
45	300-34250	Bolt 5/16" NC x 1" lg + nylon locknut	2
46	190-03042	Hose R1 3/8" x 34" lg + 1 fitting 6U 106 & 1 fitting 6U 108	1
47	9405-6x6	Elbow 90 deg. 3/8" NPT	1
48	190-03052	Hose R1 3/8" x 150" lg + 1 fitting 6U 106 & 1 fitting 6U 108	1
49	Std.	Cotter pin 1/4" x 3" lg	1

DUMP TRAILER P-50710/4E (cont'd)

RÉF.	# DE PIÈCE	DESCRIPTION	QTE
50	130-20331	Flat washer 1 5/8" i.d. x 2 1/4" o.d.	1
51	51615	Ball hitch 2 5/16"	1
51	51525	Swivel hitch	opt.
51	110-07161	Pintle hitch 3" Ø int.	opt.
52	51490	Jack 3000 lbs (includes # 53)	1
53	51408	Pin for jack	1
54	51583	Ring for side panel lock (welded)	4
55	51584-G	Side panel lock (L.H.) (welded)	2
56	51584-D	Side panel lock (R.H.) (welded)	2
57	52077	Parking light (yellow)	2
58	51599	Spring fixation plate	4
59	54010	Springs	4
60	110-20283	Road axle with hub and brakes (including # 96, 97 and 98)	2
61	Std.	U-bolt 1/2" NF x 3" x 7" round + 2 nylon locknut	8
62	300-42400	Bolt 9/16" NC x 3" lg + nylon locknut	14
63	51601	Pivot plate	8
64	54086	Pivot	2
65	52076	Parking light (red)	2
66	32229	Rear flasher light	2
67	51612	Mudguard 8" x 14"	2
68	316-32220	Teck screw 1/4-14 x 3/4" lg	4
69	52070	Light for license plate	1
70	301-38280	Bolt 7/16" NC x 1 1/4" lg + nylon locknut + 2 flat washers	2
71	54070	Hook with safety lock	2
72	54064	Chain 5/16" (10000 lbs) + hook with safety lock	2
73	110-14052	Adjustable mounting support for ball hitch	1
74	302-44490	Bolt 5/8" NF x 4 1/2" lg + nylon locknut	2
75	300-32220	Bolt 1/4" NC x 3/4" lg + nylon locknut	1
76	52069	Emergency brake switch	1
77	51614	Battery 12 V 850A	1
78	130-05751	Angle	1
79	110-04841	Tightener + 1 nylon locknut 3/8" NC + 1 nylon locknut 7/16" NC	2
80	300-36250	Bolt 3/8" NC x 1" lg + nylon locknut	1
81	51607	Battery cable 4 Ga x 10" lg	1
82	52074	Self-adhesive reflector 1 1/8" x 4 1/2" (red)	2
83	130-13371	Parking light guard	2
84	130-13441	Parking light support	2
85	190-08211	Spring 7/8" o.d. x 6 1/8" lg	1
86	357-57000	Castle nut 1 1/2" NC	1
87	150-02851	Hinge pin for rear panel	2
88	300-36370	Bolt 3/8" NC x 2 1/2" lg	2
89	Std.	Quick coupler 1/2" male	1
90	Std.	Grease fitting 1/4"-28, 45 deg.	1
91	51621	Front ball-joint (welded)	2
92	51622	Right hand rear ball-joint (welded)	1
93	51623	Left hand rear ball-joint (welded)	1
94	9205x6x6	Fitting straight 3/8" NPT	1
95	Std.	Lock pin 1/4"	1
96	110-06672	Spindle 3500 lbs	2
97	110-30771	Stub Axle 3500 lbs (welded)	4
98	54148	Hub and drum assembled with brakes	4

ASSEMBLY: HYD. ELECTRIC PUMP P-510-PHEP

170-03861

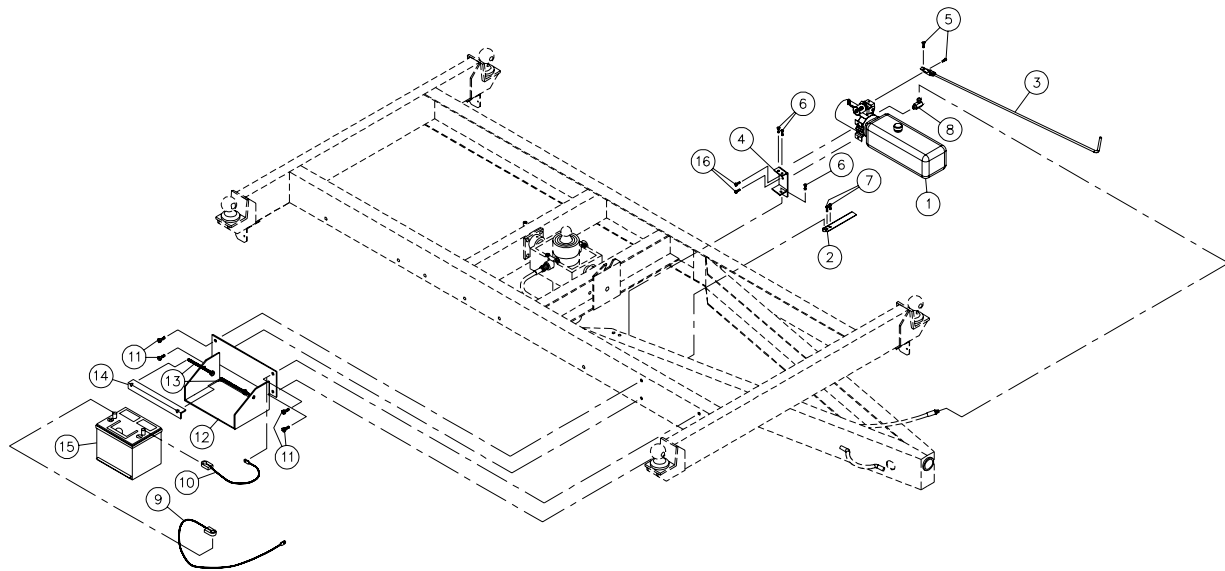

REF.	PART #	DESCRIPTION	QTY	
			P-508/3S P-510/3S	P-50710/4E
1	51624	Electric hydraulic pump	1	1
2	130-45641	Support for pump	1	1
3	110-27781	Handle	1	1
4	110-27801	Support plate for pump	1	1
5	300-34220	Bolt 5/16" NC x 3/4" lg + lock washer	2	2
6	300-34250	Bolt 5/16" NC x 1" lg + nylon locknut	3	3
7	300-34220	Bolt 5/16" NC x 3/4" lg + nylon locknut	2	2
8	9405x6x6	Fitting 90 deg.	1	1
9	51606	Battery cable 4G x 30" lg	1	1
10	51631	Battery cable 4G x 15" lg	1	inc
11	300-36250	Bolt 3/8" NC x 1" lg + nylon locknut	4	nr
12	110-06772	Battery holder	1	-
13	110-04841	Threaded rod + nylon locknut 3/8"NC + nylon locknut 7/16"NC	2	inc
14	130-05751	Angle	1	inc
15	---	Battery 12 volts	na	inc
16	300-36220	Bolt 3/8" NC x 3/4" lg + lock washer	2	2

nr = not required
na = not available
inc = included

8

ELECTRIC CIRCUIT P-50710/4E

170-01731

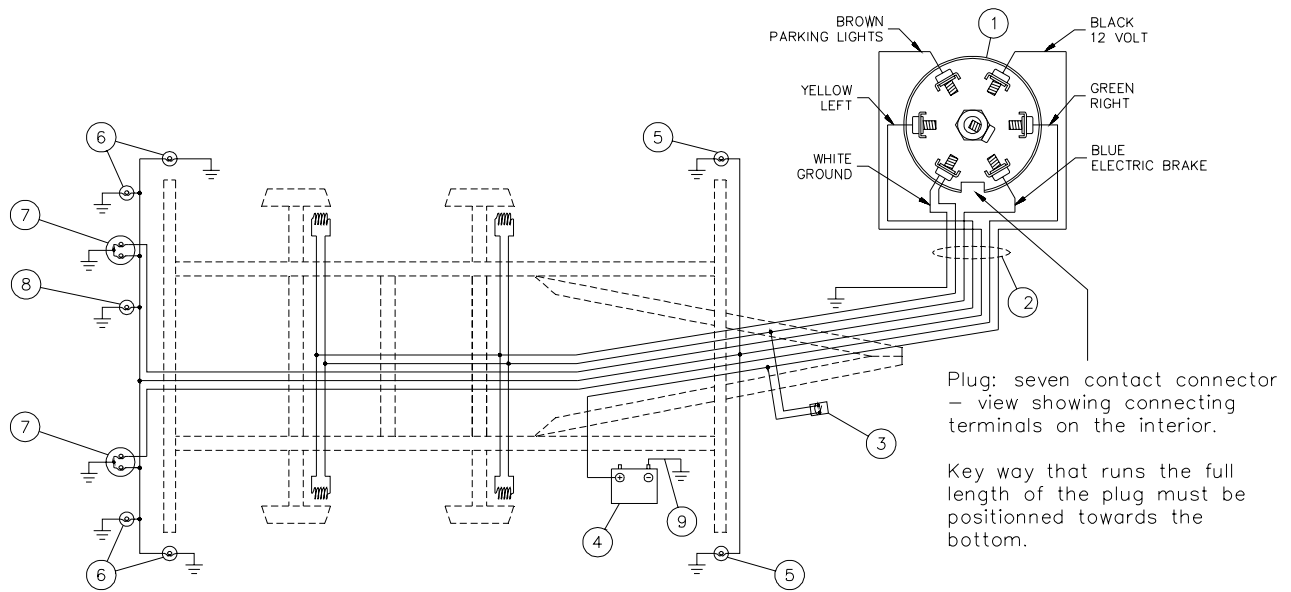

REF.	PART #	DESCRIPTION	QTY
1	52065	Connector 7 poles (trailer side)	1
2	51609	P-50710/4E conductors cable kit	1
3	52069	Emergency brake	1
4	51614	Battery 12 volts 850 Amp.	1
5	52077	Yellow parking lights	2
6	52076	Red parking lights	2
7	32229	Flashers	2
8	52070	License light	1
9	51607	Battery cable 4 GA x 10" lg	1
NI*	52078	Connector 7 poles (vehicle side)	1

*NI = Not illustrated

8

HUB H4000 # 51503

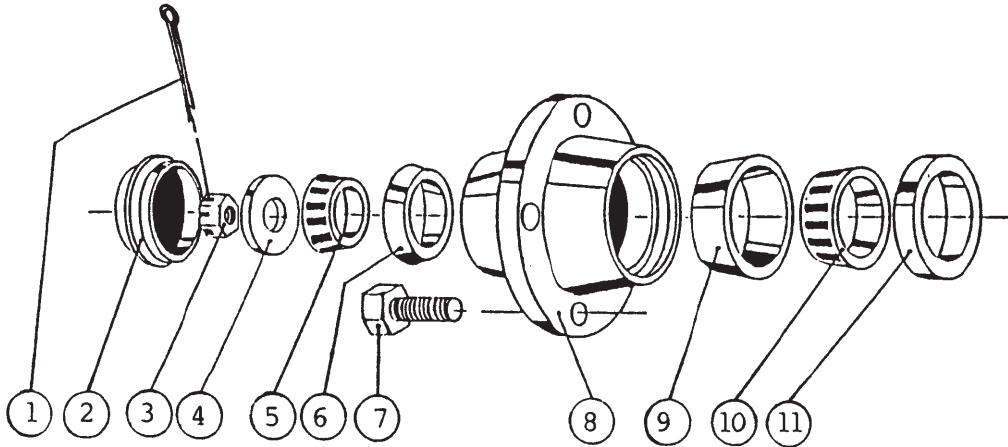

REF.	PART #	DESCRIPTION	QTY
1	Std.	Cotter pin 5/32" x 1 3/4"	1
2	51528	Dust cap D-4000 2 5/16" ø	1
3	51529	Castle nut 1" NF x 9/16" thick	1
4	Std.	Flat washer 1"	1
5	51530	Roller bearing Timken: cone no. LM67048	1
6	51531	Roller bearing Timken: cup no. LM67010	1
7	51418	Rim screw 9/16"	6
8	51532	Hub only H4000	1
9	51533	Roller bearing Timken: cup no. LM29710	1
10	51534	Roller bearing Timken: cone no. LM29749	1
11	51535	Oil seal no. CR17415	1

8

HUB H5000 #51441

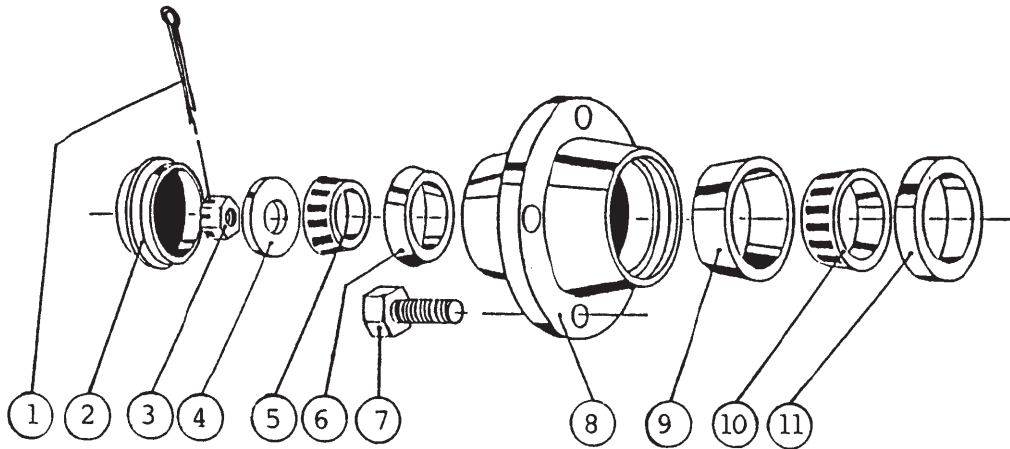

REF.	PART #	DESCRIPTION	QTY
1	Std.	Cotter pin 5/32" x 1 1/2"	1
2	51417	Dust cap 2.570" ø	1
3	51442	Castle nut 7/8" NF	1
4	Std.	Flat washer 7/8"	1
5	51416	Roller bearing Timken: cone no. 4T-LM48548	1
6	51415	Roller bearing Timken: cup no. 4T-LM48510	1
7	51418	Rim screw 9/16"	6
8	51414	Hub only H5000	1
9	51413	Roller bearing Timken: cup no. 4T-LM603011	1
10	51412	Roller bearing Timken: cone no. 4T-LM603049	1
11	51443	Oil seal no. CR20044	1

8

HUB AND DRUM 545, ELECTRIC BRAKES 10x2 1/4"

170-04121.TIF

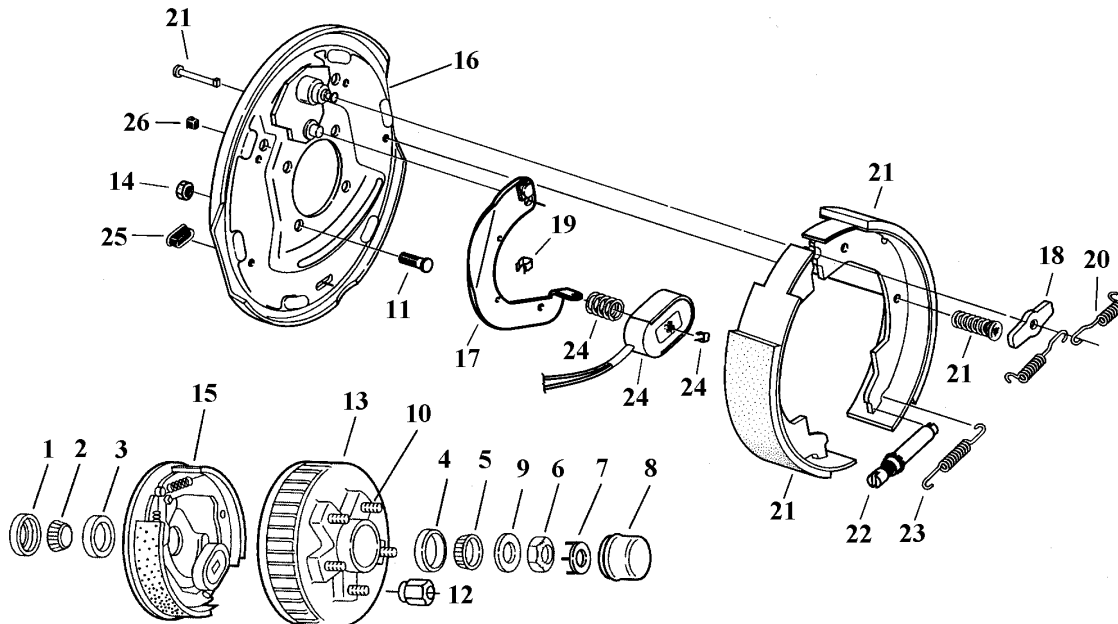

REF.	PART #	DESCRIPTION	QTY/ASS'Y
1	54152	Grease seal CR17146 or 17255VB	1
2	L68149	Roller bearing (cone)	1
3	L68111	Roller bearing (cup)	1
4	L44610	Roller bearing (cup)	1
5	L44649	Roller bearing (cone)	1
6	54139	Lock nut 1" NF	1
7	54138	Spindle nut retainer	1
8	53019	Grease cap	1
9	54106	Spindle washer	1
10	54111	1/2"-20 pressed wheel stud	5
11	54124	Brake mounting bolt Press-in 7/16-14	4
12	362-40000	1/2"-20 60 deg cone nut	5
13	54107	Hub and drum 1750 lbs	1
14	338-38000	Nut 7/16" NF + lock washer	4
15	54108	Electric brake 10 x 2 1/4 (left)	1
15	54109	Electric brake 10 x 2 1/4 (right)	1
16	54112	Backing plate Assembly	2
17	54113	LH Actuating lever arm	1
17	54114	RH Actuating lever arm	1
18	54115	Washer	1
19	54116	Wire clip	3
20	54117	Retractor spring	2
21	54118	Shoe and lining kit	1
22	54119	Adjuster assembly	1
23	54120	Adjusting screw spring	1
24	54121	Magnet kit containing	1
25	54122	Adjuster slot plug	1
26	54123	Wire grommet	1

8

DIRECTIONAL CONTROL VALVE

170-00951

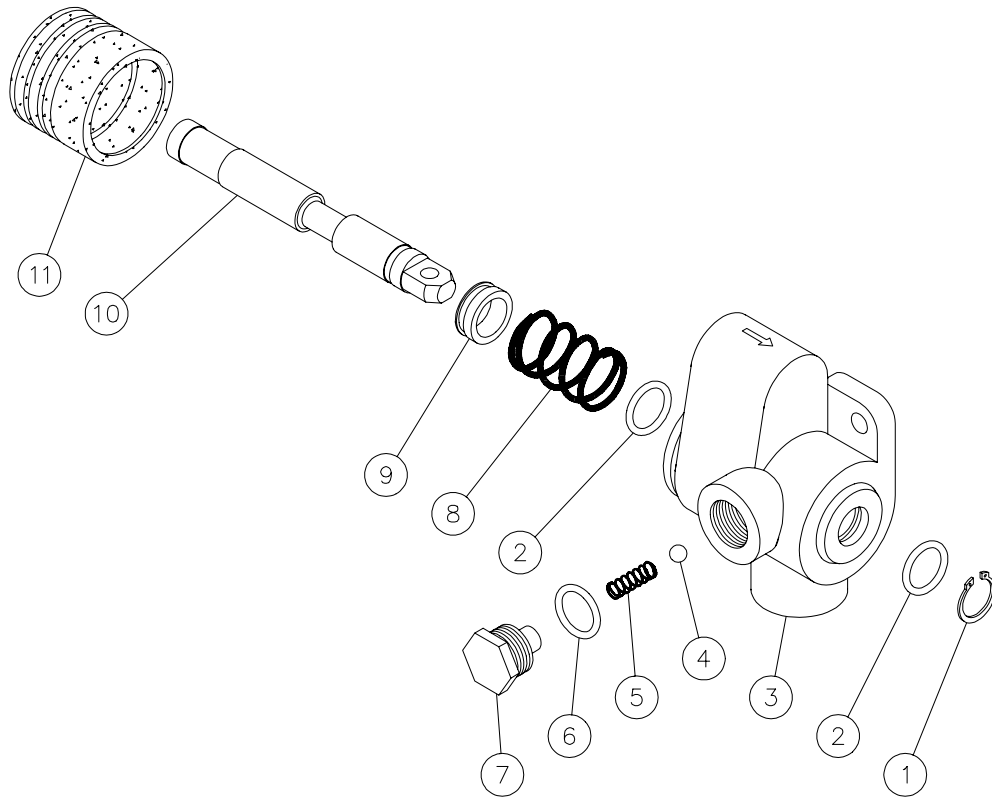

REF.	PART #	DESCRIPTION	QTY
1	649-00022	Snap ring	1
2	649-00023	O-ring	2
3	649-00024	Body	1
4	649-00025	Ball for pressure valve	1
5	649-00026	Spring for pressure valve	1
6	649-00027	O-ring	1
7	649-00028	Cap for pressure valve	1
8	649-00029	Spring	1
9	649-00030	Ring	1
10	649-00031	Spool	1
11	649-00032	Rubber boot	1

* Some parts might not be available apart.

8

TELESCOPIC CYLINDER # 51506

190-06971

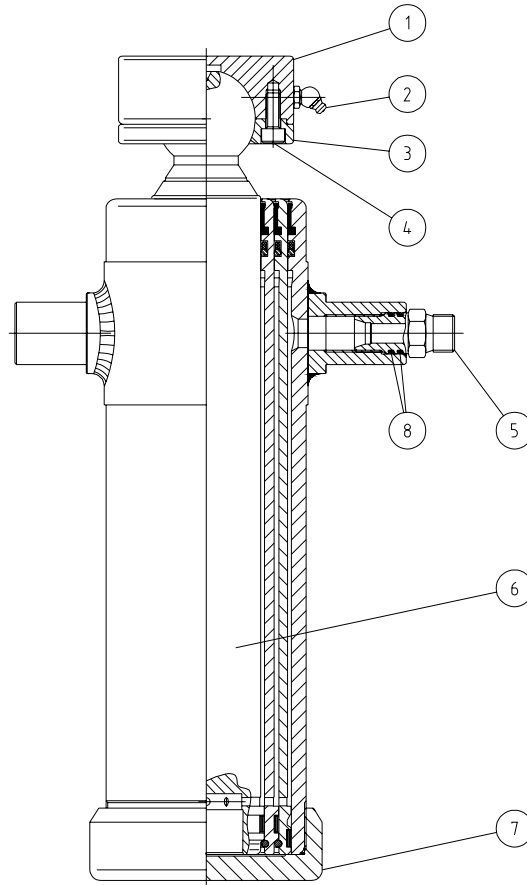

REF.	PART #	DESCRIPTION	QTY
1	51619	Ball joint seat (welded)	1
2	Std.	Grease fitting 1/4"-28 45 deg.	1
3	51620	Locking segments for ball-joint 2 7/8"	1
4	331-13220	Hex socket cap screw M8-1.25mm x 20mm (from serial # 8800 and up)	6
5	51586	Connector	1
6	51587	Piston with ball	1
7	51588	Threaded cylinder base	1
8	51589	Seal kit for connector	1
NI*	51527	Repair kit for cylinder	1

*NI = Not illustrated

* Some parts might not be available apart.



ELECTRIC HYDRAULIC PUMP M301 # 51624

170-04261.TIF

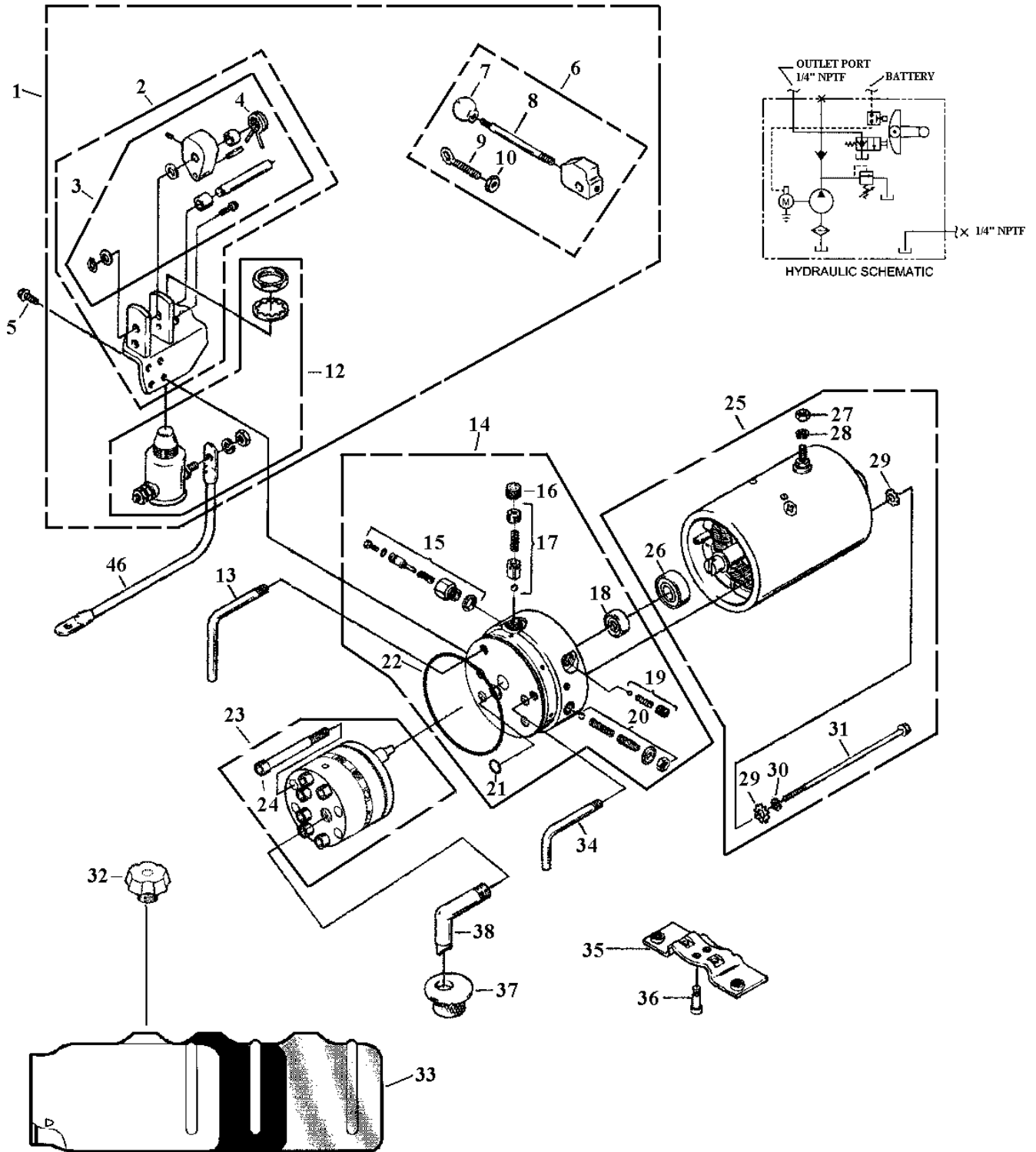

8

ELECTRIC HYDRAULIC PUMP M301 # 51624 (cont'd)







REF.	PART #	DESCRIPTION	QTY		
			51624	51625	51627
1	03412	Bracket assembly (incdingt #6 & 12)	1	1	1
2	03440	Bracket assembly including #6	1	1	1
3	03660	Parts Kit, Bracket assembly	1	1	1
4	00018	Spring torsion	1	1	1
5	07815	Screw, hex washer head, tap tite 1/4" NC x 5/8"	4	4	4
6	00175	Parts kit, Handle assembly	1	1	1
7	01157	Ball, plastic	1	1	1
8	01326	Rod, Handle 4"	1	1	1
9	01327	Eye bolt 5/16" NC x 1 7/8"	1	1	1
10	07790	Nut 5/16" NC	1	1	1
11	01373	Cable, insulated, with lugs 9" 6 GA	1	1	1
12	03322	Switch on/off (canister type)	1	1	1
13	13058	Tube return 1/8" NPT	1	1	1
14	12421	Base assembly	1	1	1
15	00235	Parts kit, Plunger	1	1	1
16	02349	Plug 3/8" NPT	1	1	1
17	07526	Parts kit, Check valve	1	1	1
18	02159	Seal	1	1	1
19	00078	Parts kit, Check valve	1	1	1
20	03766	Parts kit, Relief valve	1	1	1
21	00120	O-ring 1/2" i.d. x 5/8" o.d. x 1/16"	1	1	1
22	02352	O-ring 3 5/8" i.d. x 3 7/8" o.d. x 1/8"	1	1	1
23	K12171-250	Pump assembly	1	1	1
24	07818	Socket head cap screw 1/4"NC x 3"	4	4	4
25	08111	Electric motor 12V DC	1	1	1
26	02318	Bearing base motor	1	1	1
27	07625	Nut 5/16" NF	1	1	1
28	07781	Lock washer 5/16"	1	1	1
29	07737	Star washer 1/4"	4	4	4
30	07795	Lock washer 1/4"	2	2	2
31	07738	Socket head cap screw 1/4"NC x 6 1/2"	2	2	2
32	01143	Plug	1	1	1
33	14157	Reservoir 6" x 6 1/2" x 10" (199 po3)	-	1	-
33	14159	Reservoir 6" x 6 1/2" x 19" (432 po3)	1	-	-
33	14170	Reservoir 6 1/2" x 7 1/4" x 26" (715 po3)	-	-	1
34	13059	Tube return 1/8" NPT	1	1	1
35	04560	Bracket, Plate mount 3 1/4" c/c	1	1	1
36	07592	Socket head cap screw 3/8"NC x 1"	2	2	2
37	01134	Screen filter	1	1	1
38	01209	Tube, Filter suction 3/8" NPT 90 deg	1	1	1

* Some parts might not be available apart.







TORQUE CHART

TORQUE SPECIFICATION TABLE

Thread UNC and UNF		Grade 2 				Grade 5   				Grade 8*   			
Bolt size		Torque				Torque				Torque			
Inches	mm	Pound feet min.	max.	Newton meters min.	max.	Pound feet min.	max.	Newton meters min.	max.	Pound feet min.	max.	Newton meters min.	max.
1/4	6.35	5	6	6.8	8.13	9	11	12.2	14.9	12	15	16.3	30.3
5/16	7.94	10	12	13.6	16.3	17	20.5	23.1	27.8	24	29	32.5	39.3
3/8	9.53	20	23	27.1	31.2	35	42	47.5	57.0	45	54	61.0	73.2
7/16	11.11	30	35	40.7	47.4	54	64	73.2	86.8	70	84	94.9	113.9
1/2	12.70	45	52	61.0	70.5	80	96	108.5	130.2	110	132	149.2	179.0
9/16	14.29	65	75	88.1	101.6	110	132	149.2	179.0	160	192	217.0	260.4
5/8	15.88	95	105	128.7	142.3	150	180	203.4	244.1	220	264	298.3	358.0
3/4	19.05	150	185	203.3	250.7	270	324	366.1	439.3	380	456	515.3	618.3
7/8	22.23	160	200	216.8	271.0	400	480	542.4	650.9	600	720	813.6	976.3
1	25.40	250	300	338.8	406.5	580	696	786.5	943.8	900	1080	1220.4	1464.5
1 1/8	25.58	-	-	-	-	800	880	1084.8	1193.3	1280	1440	1735.7	1952.6
1 1/4	31.75	-	-	-	-	1120	1240	1518.7	1681.4	1820	2000	2467.9	2712.0
1 3/8	34.93	-	-	-	-	1460	1680	1979.8	2278.1	2380	2720	3227.3	3688.3
1 1/2	38.10	-	-	-	-	1940	2200	2630.6	2983.2	3160	3560	4285.0	4827.4

* Thick nuts must be used with grade 8 bolts.

Size of screw	Thread	Pitch (mm)	Grade 4T  				Grade 7T 				Grade 8T  			
			Torque				Torque				Torque			
			Pound feet min.	max.	Newton meters min.	max.	Pound feet min.	max.	Newton meters min.	max.	Pound feet min.	max.	Newton meters min.	max.
M6	UNC	1.00	3.6	5.8	4.9	7.9	5.8	9.4	7.9	12.7	7.2	10	9.8	13.6
M8	UNC	1.25	7.2	14	9.8	19	17	22	23	29.8	20	26	27.1	35.2
M10	UNC	1.5	20	25	27.1	33.9	34	40	46.1	54.2	38	46	51.5	62.3
M12	UNC	1.75	28	34	37.9	46.1	51	59	69.1	79.9	57	66	77.2	89.4
M14	UNC	2.0	49	56	66.4	75.9	81	93	109.8	126	96	109	130.1	147.7
M16	UNC	2.0	67	77	90.8	104.3	116	130	157.2	176.2	129	145	174.8	196.5
M18	UNC	2.0	88	100	119.2	136	150	168	203.3	227.6	175	194	237.1	262.9
M20	UNC	2.5	108	130	146.3	176.2	186	205	252	277.8	213	249	288.6	337.4
M8	UNF	1.0	12	17	16.3	23	19	27	25.7	36.6	22	31	29.8	42
M10	UNF	1.25	20	29	27.1	39.3	35	47	47.4	63.7	40	52	54.2	70.5
M12	UNF	1.25	31	41	42	55.6	56	68	75.9	92.1	62	75	84	101.6
M14	UNF	1.5	52	64	70.5	86.7	90	106	122	143.6	107	124	145	168
M16	UNF	1.5	69	83	93.5	112.5	120	138	162.6	187	140	158	189.7	214.1
M18	UNF	1.5	100	117	136	158.5	177	199	239.8	269.6	202	231	273.7	313
M20	UNF	1.5	132	150	178.9	203.3	206	242	279.1	327.9	246	289	333.3	391.6

Use the above torques when special torque is not given.

NOTE: These values apply to fasteners as received from supplier, dry, or when lubricated with normal engine oil. They do not apply if extreme pressure lubricants are used.

WARRANTY

PRONOVOST warrants this product to the initial purchaser for the period of one year from the date of purchase against defects in materials and workmanship.

We will replace or repair defective parts free of charge if they are returned to our plant in St-Tite, Quebec, Canada.

Transportation charges are the responsibility of the customer. This warranty is not transferable.

Hydraulic cylinders are covered by the manufacturer of these items.

All PRONOVOST spare parts purchased are covered by a three (3) month warranty.

This warranty becomes void and nul if the equipment is modified, breaks down as the result of an accident, is not operated according to manufacturer's recommendations, damaged by negligence or if maintenance has not been carried out as specified.

Our obligation is limited to the replacement or repair of the defective part. PRONOVOST accepts no responsibility for direct or indirect consequential damages of any kind.

Ce manuel est aussi disponible en français.
Veuillez téléphoner.



INNOVATION - EXCELLENCE

LES MACHINERIES PRONOVOST INC.

260, route 159,

Saint-Tite, Quebec, Canada, G0X 3H0

Tel.: (418) 365-7551, Fax: (418) 365-7954

www.pronovost.qc.ca