



**OPERATOR'S / PARTS
MANUAL**



Dump Trailers
Models

P-503

P-503HS

VISIT OUR WEBSITE



www.pronovost.qc.ca

Copyright © Les Machineries Pronovost Inc., 2002

All rights reserved.
Printed in Canada.

TABLE OF CONTENTS

Section	Item	Page
1	Introduction	5
2	Safety	6
	General Safety	6
	Safety in Operation	6
	Safety with Maintenance	7
	Safety in Transport	7
	Safety in Storage	7
3	Decals	8
	Safety decals	8
	Maintenance decals	8
4	Start-up	9
	Basic Start-up Procedures	9
5	Maintenance	10
6	Storage	11
7	Specifications	12
8	Parts List	13
	Dump Trailers P-503	13
	Dump Trailers P-503HS	15
	Manual Pump # 53056	18
	Installation of the manual pump	19
	Electric hydraulic pump	20
	Installation of the electric hydraulic pump	22
	Hub H1000	23
	Cylinder 30TR12	24
9	Torque chart	25
10	Warranty	26

INTRODUCTION

CONGRATULATIONS!

Thank you for choosing PRONOVOST. We are confident this equipment will meet your requirements in terms of quality, performance and reliability.

This manual was prepared to assist you in the safe operation of your new Dump Trailer. It contains important information which will help you achieve excellent returns with your PRONOVOST Dump Trailer for years to come.

Please read this manual before operating your Trailer and keep it for future reference.

Before using this equipment, you or any other person who will be using it must familiarize yourself with the safety recommendations, the operating and safety instructions. Please read carefully and be sure to understand and follow all recommendations and procedures.

In this manual, the right and left sides are identified while standing at the rear end of the equipment and facing it.

If you require additional information on your Dump Trailer, please contact your PRONOVOST Dealer.

NOW take a moment to enter the model, serial number and the date of purchase of your Trailer in the space provided below.

When ordering parts from your Dealer, please refer to these numbers for a fast and efficient service. Use PRONOVOST parts for replacement.

The model and serial numbers are on the name plate shown on Fig. 1.



Figure 1

MODEL: _____ ✍

SERIAL NO: _____ ✍

DATE OF PURCHASE: _____ ✍

SAFETY

GENERAL SAFETY

2

WHEN YOU SEE THIS SYMBOL



ATTENTION!

**BE ALERT
YOUR SAFETY IS INVOLVED**

This symbol "SAFETY ALERT" is used in this manual and on the safety decals on the Trailer. It warns you of the possibility of danger. Carefully read, understand and follow all safety recommendations before operating the equipment.

- 1) Careful operation is the best assurance against accidents. Carefully read this manual and follow all recommendations before operating this equipment. It is the owner's responsibility to make sure that anyone who will operate the Trailer will read this manual before operating the equipment.
- 2) Do not modify the equipment. Any non authorized modification may affect the efficiency and/or safety of the equipment.
- 3) Never operate the equipment with defective parts or if damaged in any way. Have it repaired before using it.
- 4) Make sure all fasteners are in place and properly secured or tightened. Refer to torque chart on page 25.

- 5) Hydraulic fluids under pressure can damage your skin. Do not use your hands to locate a leak.

SAFETY IN OPERATION

- 1) **WARNING!** Do not overload your trailer, do not exceed the load capacity indicated in the specifications on page 12.
- 2) Be sure there are no obstructions around the equipment and that no one stands near the equipment when in use.
- 3) Do not operate an engine in a confined or non ventilated area.
- 4) Do not perform any adjustments, cleaning, maintenance or repairs with the engine running on the towing vehicle. Preferably remove the key from the ignition.
- 5) Be careful when backing-up, make sure you have good visibility.
- 6) In the case of a Highway Service Trailer, make sure the suspension and lights are all functioning properly.
- 7) Do not forget to unlock the proper panel before dumping.
- 8) Always travel at a safe operating speed following regulations and common sense. In the case of agricultural service tires, follow the manufacturer's specified safe speed. Never exceed the speed that permits full steering and braking control at all times.

SAFETY (cont'd)

SAFETY WITH MAINTENANCE

- 1) Perform maintenance according to recommendations contained in this manual.
- 2) **Before performing any work under the raised platform, always install the safety support provided.**
- 3) If the trailer is hooked up to the tractor while performing maintenance work, make sure the engine is not running and preferably remove the ignition key.

SAFETY IN TRANSPORT

- 1) On public roads, use proper safety lights, make sure they work properly and check local regulations.
- 2) Make sure coupler is the same size as the ball hitch and well secured.
- 3) Make sure safety chains cross under the coupling mechanism and properly attached to towing vehicle.
- 4) Be alert while driving on the road. Never carry passengers.

2

DECALS

SAFETY DECALS

The safety decals are affixed wherever special safety precautions are indicated. Locate them on the equipment and read them carefully. If a decal is damaged, lost or illegible, install a new one. The following photos indicate where each one must be installed.

3

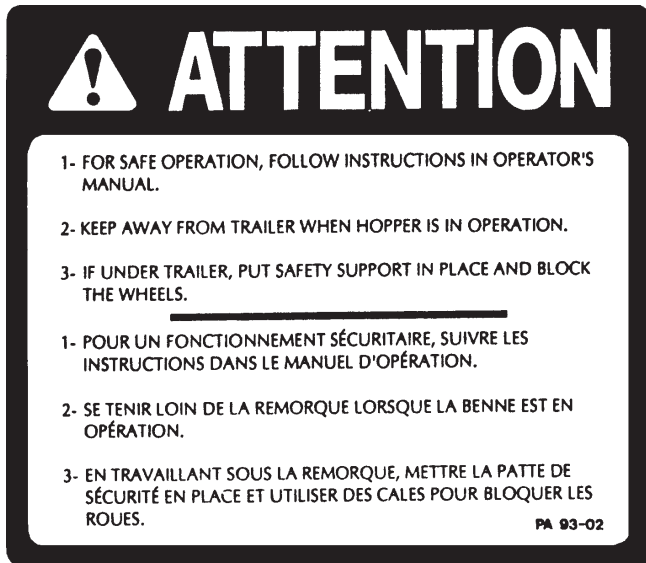

Figure 2
Decal A

Part no.: A110

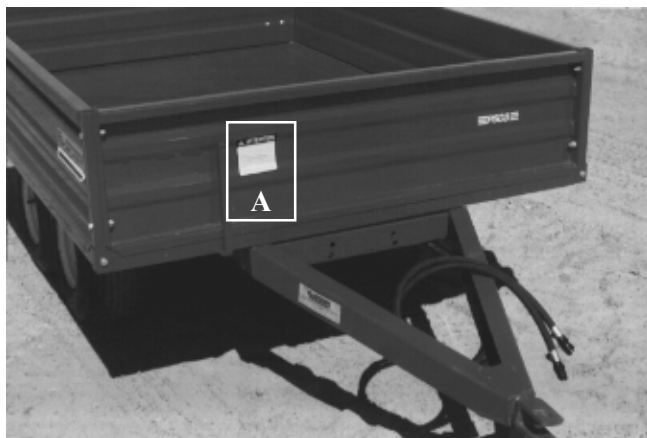

Figure 3

MAINTENANCE DECALS

The maintenance decals indicate the points requiring lubrication. Refer to maintenance section for more details.

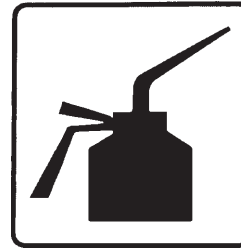

Figure 4

Part no.: A 105



Figure 5

Part no.: A 106

START-UP

BASIC START-UP PROCEDURES

- 1) Lubricate all grease fittings with a good quality multiuse grease.
- 2) Lubricate panel release mechanism, front and rear with good quality oil.
- 3) Adjust tire pressure to manufacturer's specifications.
- 4) Install wheels on hubs.
- 5) Install panels.
- 6) Install all hydraulic hoses and fittings compatible with your equipment.
- 7) Verify for adequate tightness of all fastening devices. Refer to torque chart on page 25.
- 8) Operate the hydraulic system a few times, raising and lowering the platform in order to remove any trapped air in the system. Then check the oil level in the tractor's hydraulic oil reservoir.
- 9) Do not forget to unlock the proper panel before dumping.

4

MAINTENANCE

Before performing any work under the raised platform, always install the safety support provided.

- 1) Wipe off all grease fittings with a clean cloth before adding grease in order to avoid injecting dirt or sand.
- 2) Repair or replace damaged grease fittings.
- 3) Lubricate all grease fittings every 20 hours of operation.
- 4) Check all bolts on wheels after first 5 hours of operation and then every 50 hours of operation.
- 5) Lubricate panel release mechanism, front and rear, every 20 hours of operation.
- 6) Check tire pressure every 50 hours of operation, adjust according to manufacturer's recommendation indicated on the tires.
- 7) Open, clean and lubricate wheel bearings once a year.
- 8) Check all nuts and bolts once a year. If necessary use torque chart on page 25.

5

STORAGE

- 1) Store in a cool, dry place.
- 2) Install wooden blocks under the axles to keep the tires off the ground and cover them if left exposed to the sun.
- 3) Keep all piston rods in the retracted position. This will assure better protection against the elements.
- 4) Clean your trailer.
- 5) Thoroughly inspect all parts of the trailer. Replace or repair worn or defective parts.
- 6) Touch-up or repaint if necessary.
- 7) Lubricate all points before storage.

SPECIFICATIONS

SERVICE	AGRICULTURAL	HIGHWAY
MODEL	P-503	P-503HS
Gross weight	3000 lbs / 1362 kg	3000 lbs / 1362 kg
Interior dimension on box	50" x 70" / 1270 x 1778 mm	50" x 70" / 1270 x 1778 mm
Thickness of floor	12G / 2.67 mm	12G / 2.67 mm
Side panel 12G (removable)	12" / 305 mm	12" / 305 mm
Front/back panel 12G (removable)	12"/14" / 305mm/356 mm	12"/14" / 305mm/356 mm
Platform height	22" / 559 mm	23" / 585 mm
Overall length	104" / 2642 mm	112" / 2844 mm
Overall width	54" / 1372 mm	64 1/2" / 1638 mm
Overall height	36" / 914 mm	37" / 940 mm
Free height / maximum lift	10" / 254 mm	10" / 254 mm
Thread width	36 1/4" / 921 mm	40 1/16" / 1018 mm
Dumping angle (back)	47°	47°
Dumping angle (2 sides)	--	--
Central unloading hatch	--	--
Axle	Tandem	Tandem
Suspension	--	Springs
Hubs	4 bolts	4 bolts
Hub capacity	1000 lbs / 454 kg	1000 lbs / 454 kg
Spindles	1 1/4" / 32 mm	1 1/4" / 32 mm
Wheels	4	4
Wheel dimensions	8.5 x 8 x 4	8.5 x 8 x 4
Tires (standard)	18 x 8.5 x 8 4 ply	18.5 x 8.5 x 8 4 ply
Hitch: clevis/swivel	standard	--
Hitch: ball coupler 2" dia.	--	standard
Electric brakes	--	--
Safety chain	--	standard
Hydraulic electric pump	option	option
Battery holder	option	option
Light system (12 V)	--	standard
Oil volume required	--	--
Cylinder	1 double acting	1 double acting
Hitch weight (empty)	50 lbs / 23 kg	50 lbs / 23 kg
Total weight	565 lbs / 257 kg	565 lbs / 257 kg

Design and specifications subject to change without notice.

*Removable panel.

DUMP TRAILER P-503

170-02265

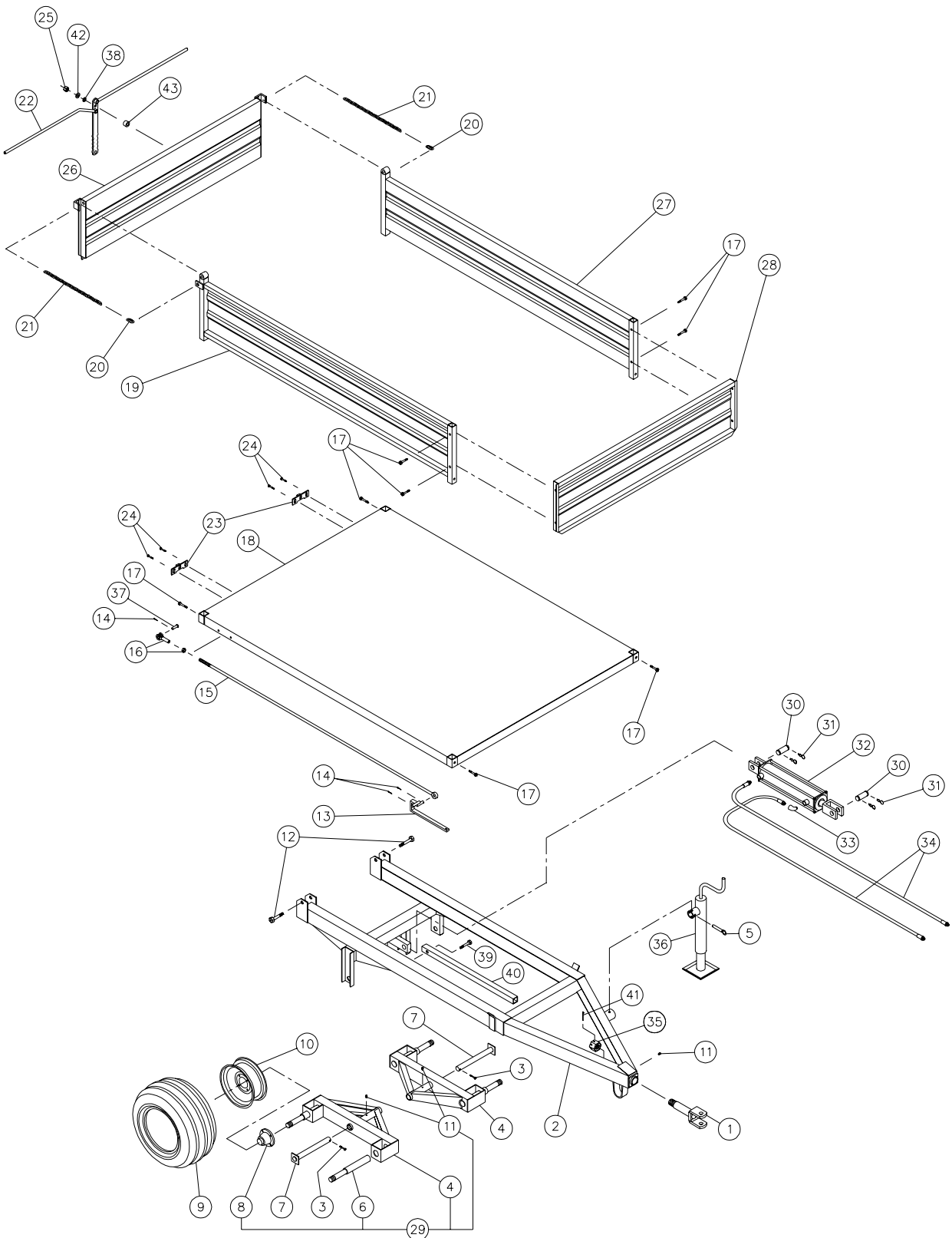

8

DUMP TRAILER P-503 (cont'd)

REF.	PART #	DESCRIPTION	QTY
1	110-12151	Swivel hitch	1
2	120-02301	Frame	1
3	Std.	Cotter pin 3/16" x 2" lg	2
4	110-12091	Tandem frame	2
5	51408	Pin for jack	1
6	150-02361	Spindle 1 1/4"	4
7	110-12101	Clevis pin 1" ø	2
8	53015	Hub # H-1000 complete (see details page 21)	4
9	PN-18858	Tire 18 x 8.5 x 8 4 ply	4
9	PN-185858	Road tire 18.5 x 8.5 x 8 4 ply	-
10	R874	Rim 8" x 7" - 4 holes	4
11	Std.	Grease fitting 1/4"-28 straight	3
12	300-44430	Bolt 5/8" NC x 3 1/2" lg + nylon locknut	2
13	110-12141	Lever for rear panel locking mechanism	1
14	Std.	Cotter pin 1/8" x 1" lg	2
15	110-12111	Rod 1/2" for lock	1
16	51435	Clevis 1/2" NF + nut 1/2" NF	1
17	300-36340	Bolt 3/8" NC x 2" lg + nut & nylon locknut	8
18	120-02311	Platform	1
19	110-12121	Right panel	1
20	53050	Quick link 1/4" x 1 3/4" lg	2
21	190-03301	Chain 7/32" x 18" lg	2
22	110-16761	Rear panel lock assembly	1
23	110-16731	Lower tailgate hinge (adjustable)	2
24	300-36280	Bolt 3/8" NC x 1 1/4" lg + flat washer + nylon locknut	4
25	346-41000	Thin nylon locknut 1/2" NC	1
26	110-02832	Rear panel	1
27	110-12122	Left panel	1
28	110-12131	Front panel	1
29	110-12092	Tandem assembly	2
30	53016	Clevis pin 1" ø	2
31	Std.	Hitch pin clip 3/16"	4
32	30TR12	Hydraulic cylinder 3" ø x 12" (see details page 22)	1
33	Std.	Elbow 1/2" 90° 9405x8x8	1
34	190-03291	Hose 3/8" x 7'8" lg + 1 fitting 6U-108 + 1 fitting 6U-106	2
35	357-54000	Castle nut 1 1/4" NF	1
36	51407	Jack 2000 lbs (includes no. 5)	1
37	51436	Clevis pin 1/2" x 1 3/4"lg	1
38	373-46500	Spring tension washer 1/2"	1
39	300-40355	Bolt 1/2" NC x 2 1/4" lg + nylon locknut	1
40	160-06051	Safety support	1
41	Std.	Cotter pin 3/32" x 2" lg	1
42	376-40000	Flat washer 1/2"	1
43	160-07941	Spacer	1

DUMP TRAILER P-503HS

170-03342

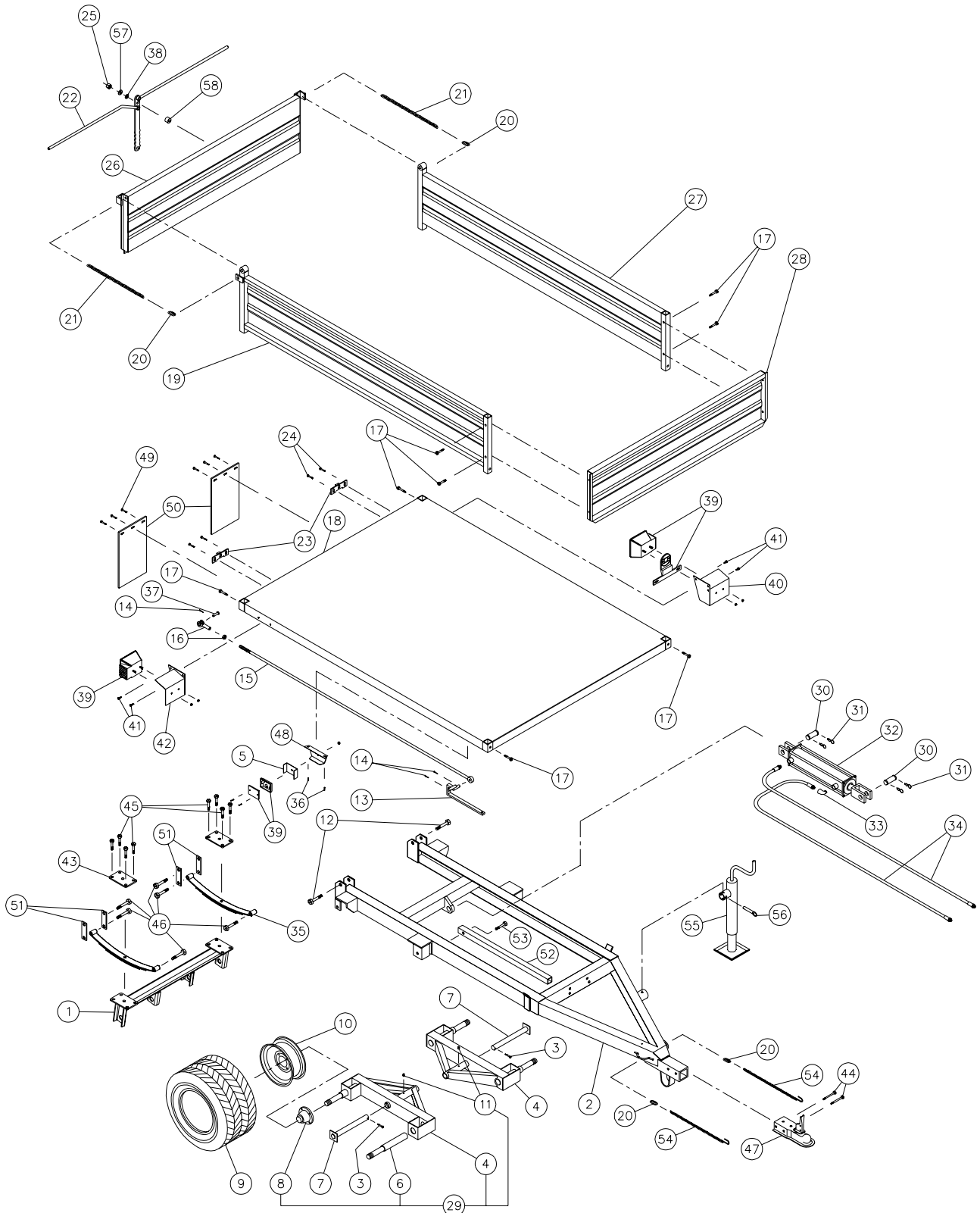

8

DUMP TRAILER P-503HS (cont'd)

REF.	PART #	DESCRIPTION	QTY
1	110-21721	Swivel hitch	1
2	120-04371	Frame	1
3	Std.	Cotter pin 3/16" x 2"lg	2
4	110-12091	Tandem frame	2
5	130-13371	Front light protector	2
6	150-02361	Spindle 1 1/4"	4
7	110-12101	Clevis pin 1" ø	2
8	53015	Hub # H-1000 complete	4
9	PN-185858	Road tire 18.5 x 8.5 x 8 4 ply	4
10	R874	Rim 8" x 7" - 4 holes	4
11	Std.	Grease fitting 1/4"-28 straight	2
12	300-44430	Bolt 5/8" NC x 3 1/2" lg + nylon locknut	2
13	110-12141	Lever for rear panel locking mechanism	1
14	Std.	Cotter pin 1/8" x 1" lg	2
15	110-12111	Rod 1/2" for lock	1
16	51435	Clevis 1/2" NF + nut 1/2" NF	1
17	300-36340	Bolt 3/8" NC x 2" lg + nylon locknut	8
18	120-02311	Platform	1
19	110-12121	Right panel	1
20	53050	Quick link 1/4" x 1 3/4" lg	4
21	190-03301	Chain 7/32" x 18" lg	2
22	110-16761	Rear panel lock assembly	1
23	110-16731	Lower tailgate hinge (adjustable)	2
24	300-36280	Bolt 3/8" x 1 1/4" lg + nylon locknut & flat washer	4
25	346-41000	Nylon locknut thin 1/2" NC	1
26	110-02832	Rear panel	1
27	110-12122	Left panel	1
28	110-12131	Front panel	1
29	110-12092	Tandem assembly	2
30	53016	Clevis pin 1" ø	2
31	Std.	Hitch pin clip 3/16"	4
32	30TR12	Cylinder 3" ø x 12" stroke	1
33	Std.	Elbow 1/2" 90° 9405 x 8 x 8	1
34	190-03291	Hose 3/8" x 120" lg + 1 fitting 6U-108 + 1 fitting 6U-106	2
35	54010	Spring	2
36	316-20190	«Tecks» screw 10-16 x 1/2" lg	8
37	51436	Clevis pin 1/2" x 1 37/64" lg	1
38	373-46500	Spring tension washer 1/2"	1
39	53060	Road light kit	1
40	110-11952	Rear light support (L.H.)	1
41	300-32205	Bolt 1/4" x 5/8" lg + nylon locknut	4
42	110-11951	Rear light support (R.H.)	1
43	130-32011	Spring back plate	2
44	300-40430	Bolt 1/2" NC x 3 1/2" lg + nylon locknut	2
45	300-40340	Bolt 1/2" NC x 2" lg + nylon locknut	8
46	300-42400	Bolt 9/16" NC x 3" lg + nylon locknut	6
47	53062	Ball hitch 2"	1
48	130-13381	Light support	2
49	300-32250	Bolt 1/4" NC x 1" lg + flat washer + nylon locknut	6
50	51612	Mudguard 8" x 14"	2

DUMP TRAILER P-503HS (cont'd)

REF.	PART #	DESCRIPTION	QTY
51	54012	Pivot plates	4
52	160-06051	Safety prop	1
53	300-40355	Bolt 1/2" NC x 2 1/4" lg + nylon locknut	1
54	53065	Safety chain + hook	2
55	51407	Jack 2000 lbs	1
56	51408	Pin for jack	1
57	376-40000	Flat washer 1/2"	1
58	160-07941	Spacer	1

MANUAL PUMP #53056 (106.3.20)

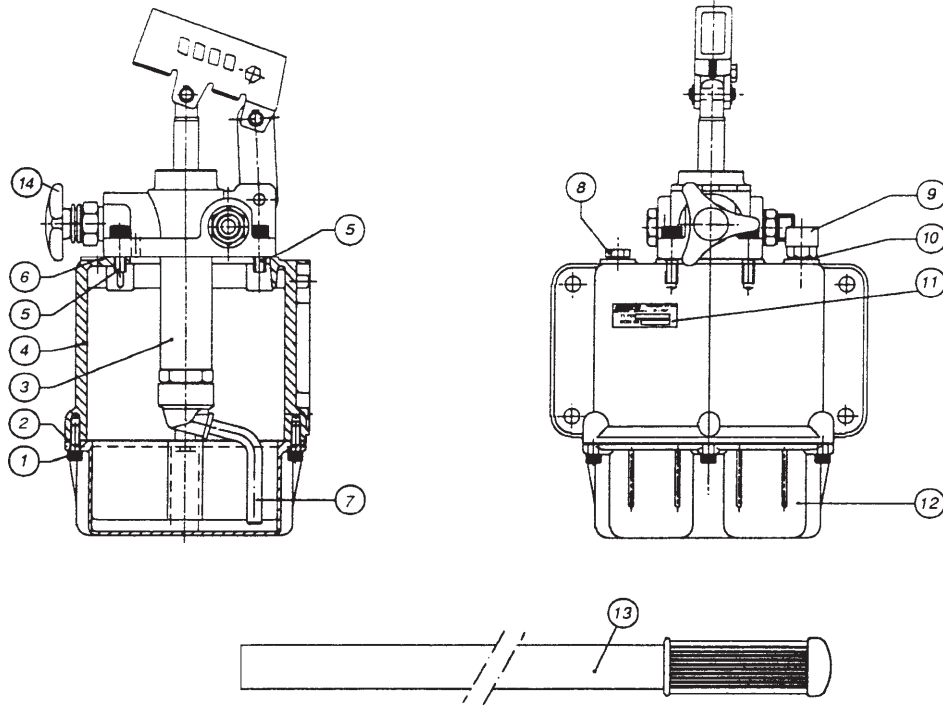

8

REF.	PART #	CODE #	DESCRIPTION	QTY
1	53032	502.2.441	Screw for reservoir mounting	8
2	53033	507.3.182	Reservoir gasket	1
3	53034	106.4.29	PMSS 45 Hand-Pump only (no body)	1
4	53035	514.3.89	Pump main body	1
5	53036	502.3.566	Screw M8 x 25	4
6	53037	507.3.208	Pump gasket	1
7	53038	541.4.36	Suction pipe for 3 lt. reservoir	1
8	53039	540.2.49	Oil filler plug	1
9	53040	118.10.106	Breather cap	1
10	53041	116.9.158	Aluminum washer	1
11	53042	513.13.963	Name plate	1
12	53043	514.5.78	Reservoir (3 lt.)	1
13	53044	106.0.78	Lever PM 45	1
14	53057	500.1.99	Relief valve knob	1
NI*	53045	106.900.51	Gasket kit	1
NI*	PHM 3003		Pump #53056 with installation hardware	1

*NI = Not illustrated

INSTALLATION OF THE MANUAL PUMP #53056 (106.3.20)

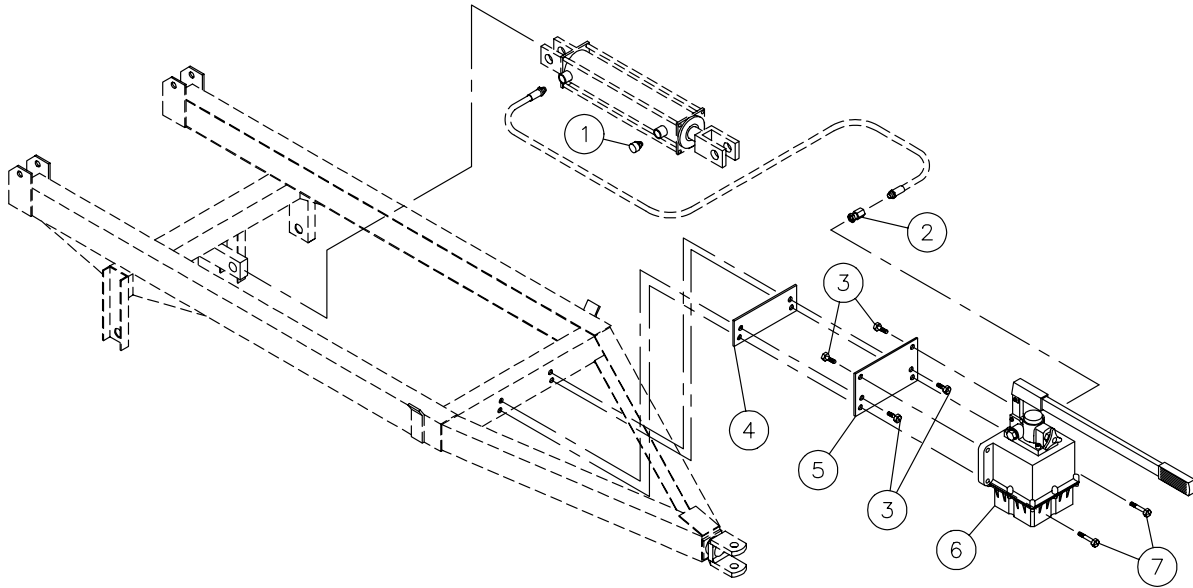

REF.	PART #	DESCRIPTION	QTY
1	669-02501	Vent plug 1/2" NPT	1
2	664-21515	Fitting straight 3/8" NPT fem. x 3/8" NPT fem. swivel	1
3	Std.	Bolt 7/16" NC x 1 1/2" lg + nylon locknut	4
4	140-05091	Spacer 1/2" x 3" x 8 1/2"	1
5	130-07851	Mounting plate 3/16" x 5" x 8 1/2"	1
6	53056	Manual hydraulic pump	1
7	Std.	Bolt 7/16" NC x 2 1/2" lg + nylon locknut	2

ELECTRIC HYDRAULIC PUMP # 613-00001

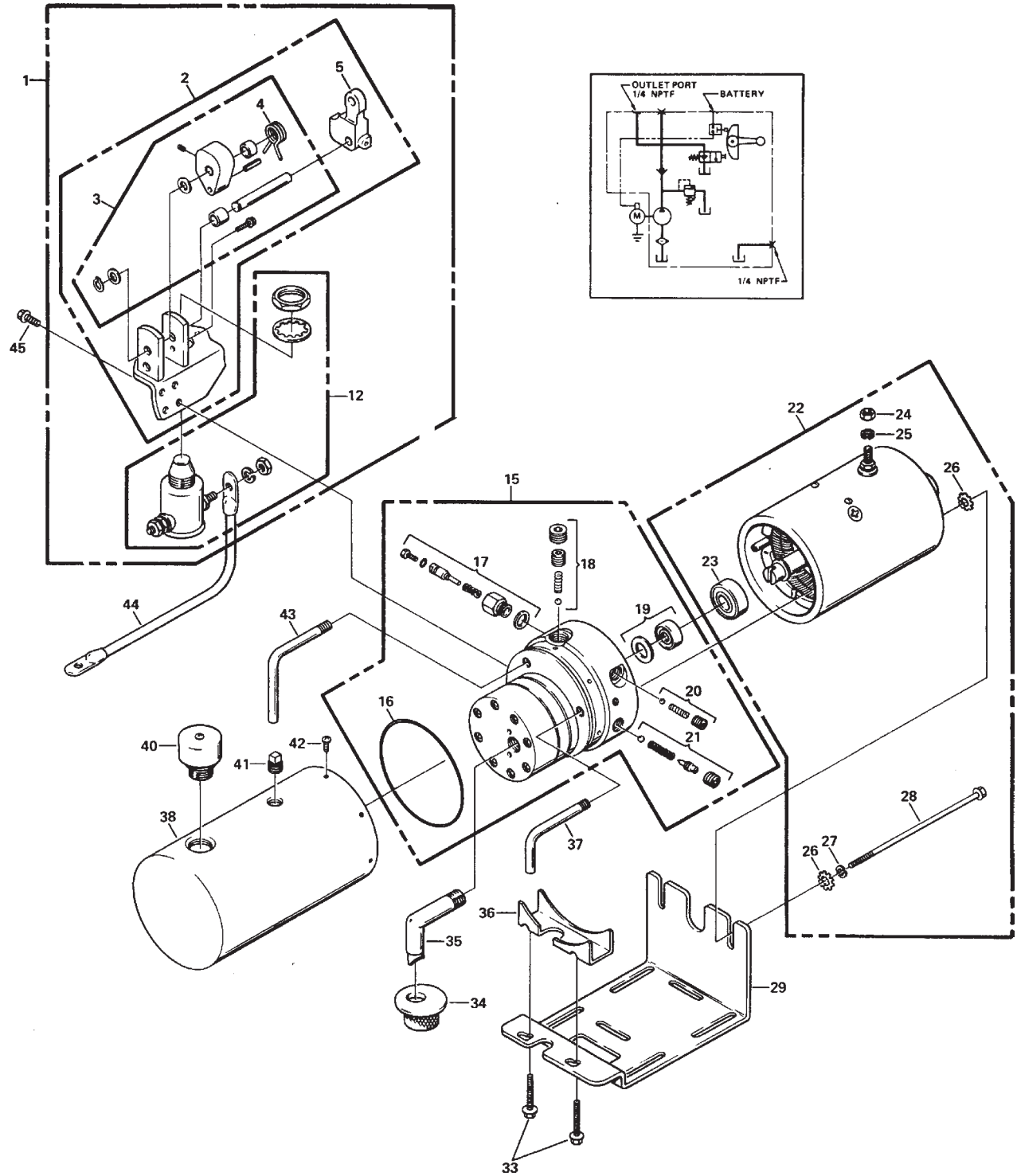

8

ELECTRIC HYDRAULIC PUMP # 613-00001 (cont'd)

REF.	PART #	DESCRIPTION	QTY
1	51537	Bracket assembly with mounting plate and start switch	1
2	51538	Bracket assembly with mounting plate	1
3	51539	Bracket assembly only	1
4	51540	Torsion spring	1
5	51541	Block	1
12	51542	Start switch	1
15	51543	Pump assembly (gear code 05)	1
16	51544	Industrial o-ring (3 5/8" x 3 7/8" x 1/8")	1
17	51545	Plunger	1
18	51546	Main check valve	1
19	51547	Seal and gasket	1
20	51548	Descending check valve	1
21	51549	Relief valve	1
22	51550	Electric motor 12V DC	1
23	51551	Ball bearing	1
24	Std.	Nut 5/16"-24	1
25	Std.	Lock washer 5/16"	1
26	Std.	Star washer 1/4"	4
27	Std.	Lock washer 1/4"	2
28	Std.	Bolt 1/4"-20 x 6 1/2"	2
29	619-00001	Mounting plate	1
33	619-00002	Bolt 1/4"-20 x 1 3/8" lg	2
34	51552	Filter	1
35	51553	Filter (suction tube) 3/8" NPT 90°	1
36	619-00003	Mounting plate adaptor	1
37	51554	Return tube 1/8"	1
38	619-00000	Reservoir 6" Ø x 8" lg, 158 in ³ usable	1
40	51556	Vent plug	1
41	51557	Square head plug	1
42	Std.	Screw 10-24 x 3/8"	6
43	51558	Return tube (1/8 NPT)	1
44	51559	Insulated cable with lugs 9" 6 gauge	1
45	Std.	Flange hex. head screw (tap tite) 1/4"-20 x 5/8"	4

* Some parts might not be available apart.

INSTALLATION OF THE ELECTRIC HYDRAULIC PUMP # 613-00001

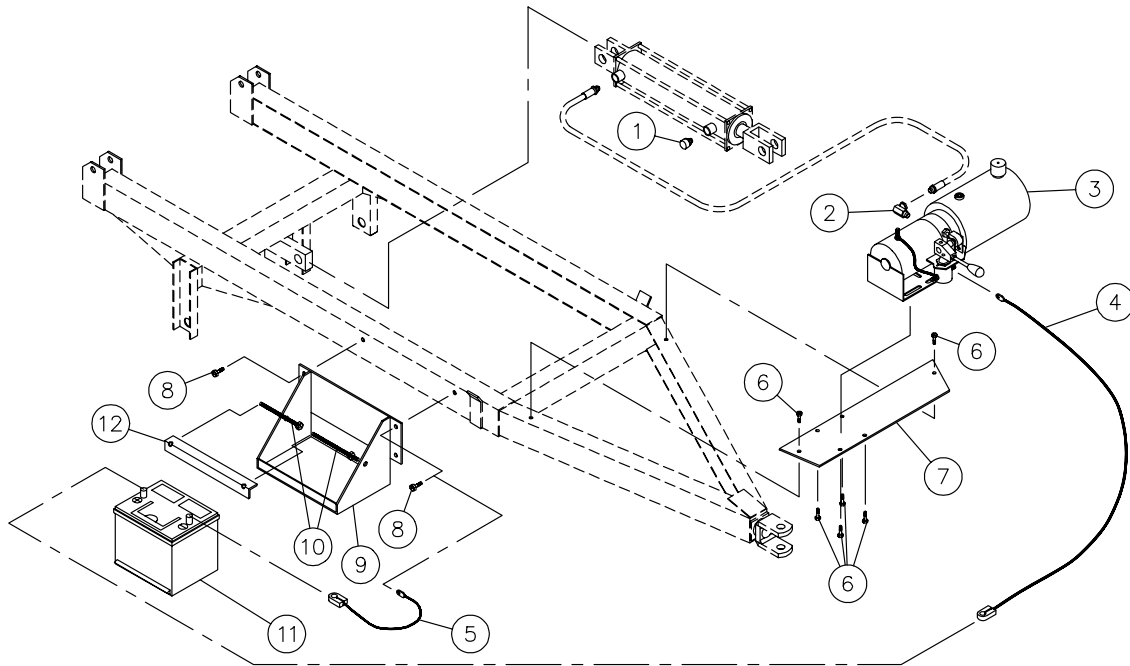

REF.	PART #	DESCRIPTION	QTY
1	669-02501	Vent plug 1/2" NPT	1
2	666-11515	Fitting 90° 3/8" NPTM x 3/8" NPTM swivel	1
3	613-00001	Electric hydraulic pump	1
4	53063	Battery cable 4G x 36" lg	1
5	51607	Battery cable 4G x 10" lg	1
6	Std.	Bolt 5/16" NC x 1" lg + nylon locknut & flat washer	6
7	130-07871	Support plate	1
8	Std.	Boulon 3/8" NC x 1 1/4" lg + écrou à blocage de nylon	2
9	110-06772	Battery holder	1
10	110-04841	Threaded rod 3/8" NC + 1 nylon locknut 3/8" & 1 nylon locknut 7/16"	2
11	- - -	Battery 540 amp. minimum (not included)	1
12	130-05751	Angle	1

8

HUB H1000

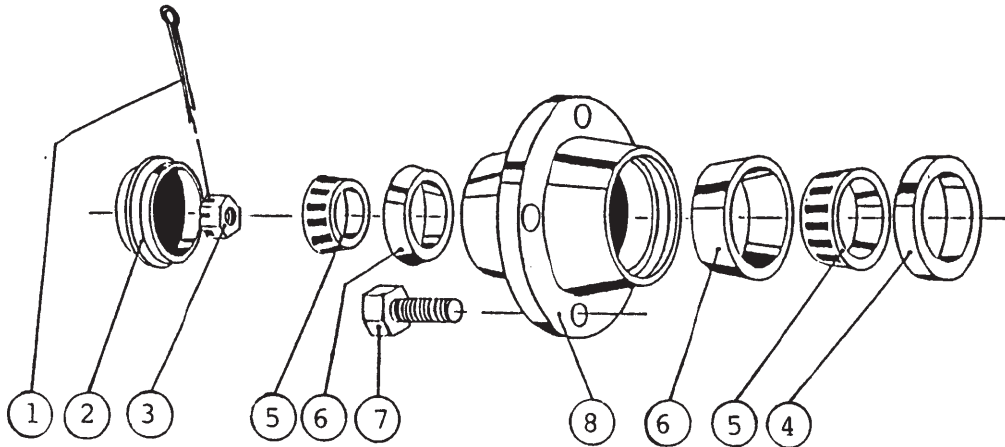

REF.	PART #	DESCRIPTION	QTY
1	Std.	Cotter pin 3/16" x 1 1/2"	1
2	53019	Dust cap 1.973 dia.	1
3	51529	Castle nut 1" NF noir	1
4	53021	Oil seal no. CR523696	1
5	53022	Roller bearing Timken: cone no. L44643	2
6	53023	Roller bearing Timken: cup no. L44610	2
7	53024	Rim screw 1/2"	4
8	53025	Hub only H1000	1

CYLINDER 30TR12

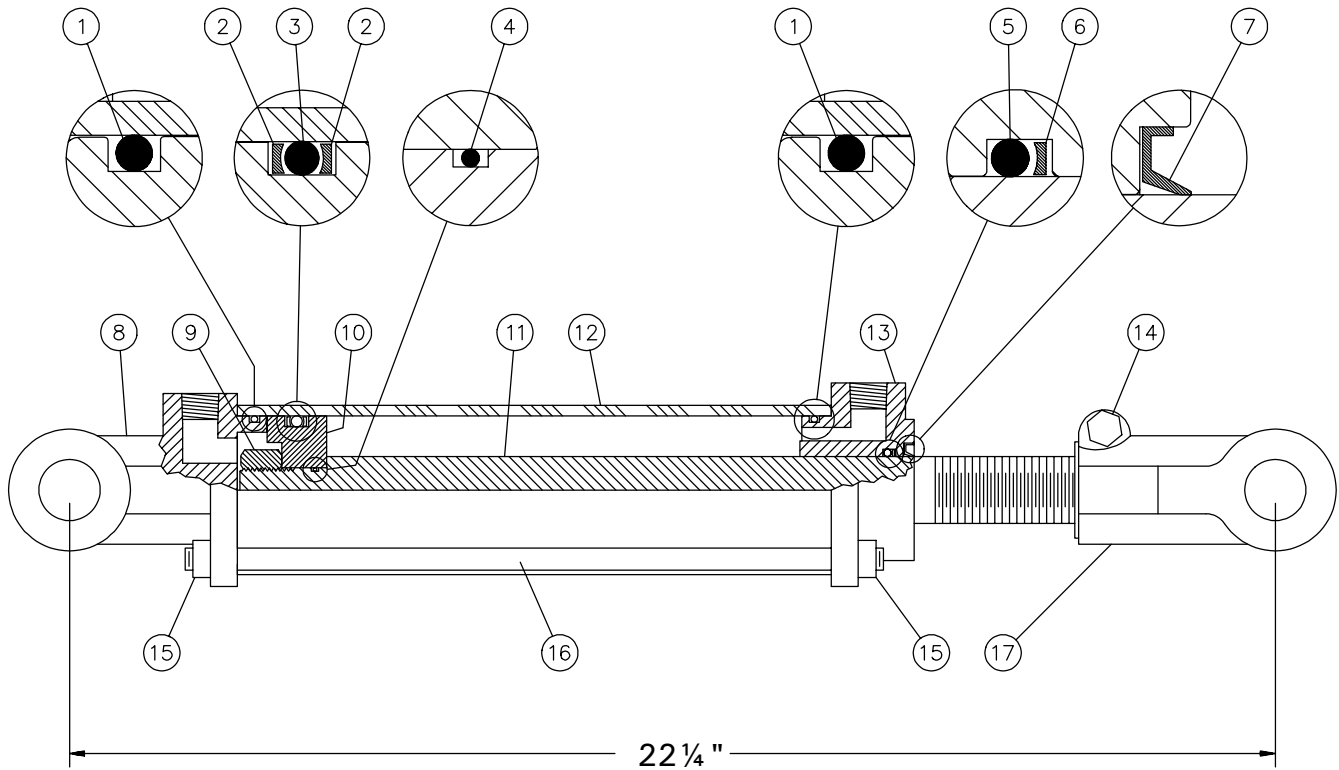







REF.	PART #	DESCRIPTION	QTY
1	See RK30TR	O-ring	2
2	See RK30TR	Back-up ring	2
3	See RK30TR	O-ring	1
4	See RK30TR	O-ring	1
5	See RK30TR	O-ring	1
6	See RK30TR	Back-up ring	1
7	See RK30TR	Wiper	1
8	492402	Yoke (for 3" tube)	1
9	Std.	Nut 3/4" NF	1
10	492432	Piston 3" ø	1
11	492042	Piston rod 1 1/4"	1
12	491742	Cylinder body 3" ø	1
13	492440	Cylinder head (for 3" tube)	1
14	Std.	Bolt 3/8" NC x 2 1/4" + nut	1
15	Std.	Nut 3/8" NC	8
16	Std.	Threaded rod 3/8" NC	4
17	458600	Yoke (for 1 1/4" rod)	1
NI*	8183	Pin 1" ø + cotter pin	2
NI*	RK30TR	Repair kit for cylinder 3" (includes # 1, 2, 3, 4, 5, 6, & 7)	1





*NI = Not illustrated

TORQUE CHART

TORQUE SPECIFICATION TABLE

Thread UNC and UNF		Grade 2 				Grade 5   				Grade 8*   			
Bolt size		Torque				Torque				Torque			
Inches	mm	Pound feet min.	max.	Newton meters min.	max.	Pound feet min.	max.	Newton meters min.	max.	Pound feet min.	max.	Newton meters min.	max.
1/4	6.35	5	6	6.8	8.13	9	11	12.2	14.9	12	15	16.3	30.3
5/16	7.94	10	12	13.6	16.3	17	20.5	23.1	27.8	24	29	32.5	39.3
3/8	9.53	20	23	27.1	31.2	35	42	47.5	57.0	45	54	61.0	73.2
7/16	11.11	30	35	40.7	47.4	54	64	73.2	86.8	70	84	94.9	113.9
1/2	12.70	45	52	61.0	70.5	80	96	108.5	130.2	110	132	149.2	179.0
9/16	14.29	65	75	88.1	101.6	110	132	149.2	179.0	160	192	217.0	260.4
5/8	15.88	95	105	128.7	142.3	150	180	203.4	244.1	220	264	298.3	358.0
3/4	19.05	150	185	203.3	250.7	270	324	366.1	439.3	380	456	515.3	618.3
7/8	22.23	160	200	216.8	271.0	400	480	542.4	650.9	600	720	813.6	976.3
1	25.40	250	300	338.8	406.5	580	696	786.5	943.8	900	1080	1220.4	1464.5
1 1/8	25.58	-	-	-	-	800	880	1084.8	1193.3	1280	1440	1735.7	1952.6
1 1/4	31.75	-	-	-	-	1120	1240	1518.7	1681.4	1820	2000	2467.9	2712.0
1 3/8	34.93	-	-	-	-	1460	1680	1979.8	2278.1	2380	2720	3227.3	3688.3
1 1/2	38.10	-	-	-	-	1940	2200	2630.6	2983.2	3160	3560	4285.0	4827.4

* Thick nuts must be used with grade 8 bolts.

Size of screw	Thread	Pitch (mm)	Grade 4T  				Grade 7T 				Grade 8T  			
			Torque				Torque				Torque			
			Pound feet min.	max.	Newton meters min.	max.	Pound feet min.	max.	Newton meters min.	max.	Pound feet min.	max.	Newton meters min.	max.
M6	UNC	1.00	3.6	5.8	4.9	7.9	5.8	9.4	7.9	12.7	7.2	10	9.8	13.6
M8	UNC	1.25	7.2	14	9.8	19	17	22	23	29.8	20	26	27.1	35.2
M10	UNC	1.5	20	25	27.1	33.9	34	40	46.1	54.2	38	46	51.5	62.3
M12	UNC	1.75	28	34	37.9	46.1	51	59	69.1	79.9	57	66	77.2	89.4
M14	UNC	2.0	49	56	66.4	75.9	81	93	109.8	126	96	109	130.1	147.7
M16	UNC	2.0	67	77	90.8	104.3	116	130	157.2	176.2	129	145	174.8	196.5
M18	UNC	2.0	88	100	119.2	136	150	168	203.3	227.6	175	194	237.1	262.9
M20	UNC	2.5	108	130	146.3	176.2	186	205	252	277.8	213	249	288.6	337.4
M8	UNF	1.0	12	17	16.3	23	19	27	25.7	36.6	22	31	29.8	42
M10	UNF	1.25	20	29	27.1	39.3	35	47	47.4	63.7	40	52	54.2	70.5
M12	UNF	1.25	31	41	42	55.6	56	68	75.9	92.1	62	75	84	101.6
M14	UNF	1.5	52	64	70.5	86.7	90	106	122	143.6	107	124	145	168
M16	UNF	1.5	69	83	93.5	112.5	120	138	162.6	187	140	158	189.7	214.1
M18	UNF	1.5	100	117	136	158.5	177	199	239.8	269.6	202	231	273.7	313
M20	UNF	1.5	132	150	178.9	203.3	206	242	279.1	327.9	246	289	333.3	391.6

Use the above torques when special torque is not given.

NOTE: These values apply to fasteners as received from supplier, dry, or when lubricated with normal engine oil. They do not apply if extreme pressure lubricants are used.

WARRANTY

PRONOVOST warrants this product to the initial purchaser for the period of one year from the date of purchase against defects in materials and workmanship.

We will replace or repair defective parts free of charge if they are returned to our plant in St-Tite, Quebec, Canada.

Transportation charges are the responsibility of the customer. This warranty is not transferable.

Hydraulic cylinders are covered by the manufacturer of these items.

All PRONOVOST spare parts purchased are covered by a three (3) month warranty.

This warranty becomes void and nul if the equipment is modified, breaks down as the result of an accident, is not operated according to manufacturer's recommendations, damaged by negligence or if maintenance has not been carried out as specified.

Our obligation is limited to the replacement or repair of the defective part. PRONOVOST accepts no responsibility for direct or indirect consequential damages of any kind.

Ce manuel est aussi disponible en français.
Veuillez téléphoner.



INNOVATION - EXCELLENCE

LES MACHINERIES PRONOVOST INC.
260, route 159,
Saint-Tite, Quebec, Canada, G0X 3H0
Tel.: (418) 365-7551, Fax: (418) 365-7954
E-mail: info@pronovost.qc.ca
Website: www.pronovost.qc.ca