

IRONOVOST

OWNER'S MANUAL



Dump Trailers Models

P-502

P-503

P-503H

Copyright © Les Machineries Pronovost Inc., 1994

All rights reserved.

Printed in Canada.

TABLE OF CONTENTS

Section	Item	Page
1	Introduction	5
2	Safety	6
	General Safety	6
	Safety in Operation	6
	Safety with Maintenance	7
	Safety in Transport	7
	Safety in Storage	7
3	Decals	8
	Safety decals	8
	Maintenance decals	8
4	Start-up	9
	Basic Start-up Procedures	9
5	Maintenance	10
6	Storage	11
7	Specifications	12
8	Parts List	13
	Dump Trailers P-503	13
	Manual Pump # 53056	15
	Hub H1000	16
	Cylinder 30TR12	17
9	Torque chart	18
10	Warranty	19

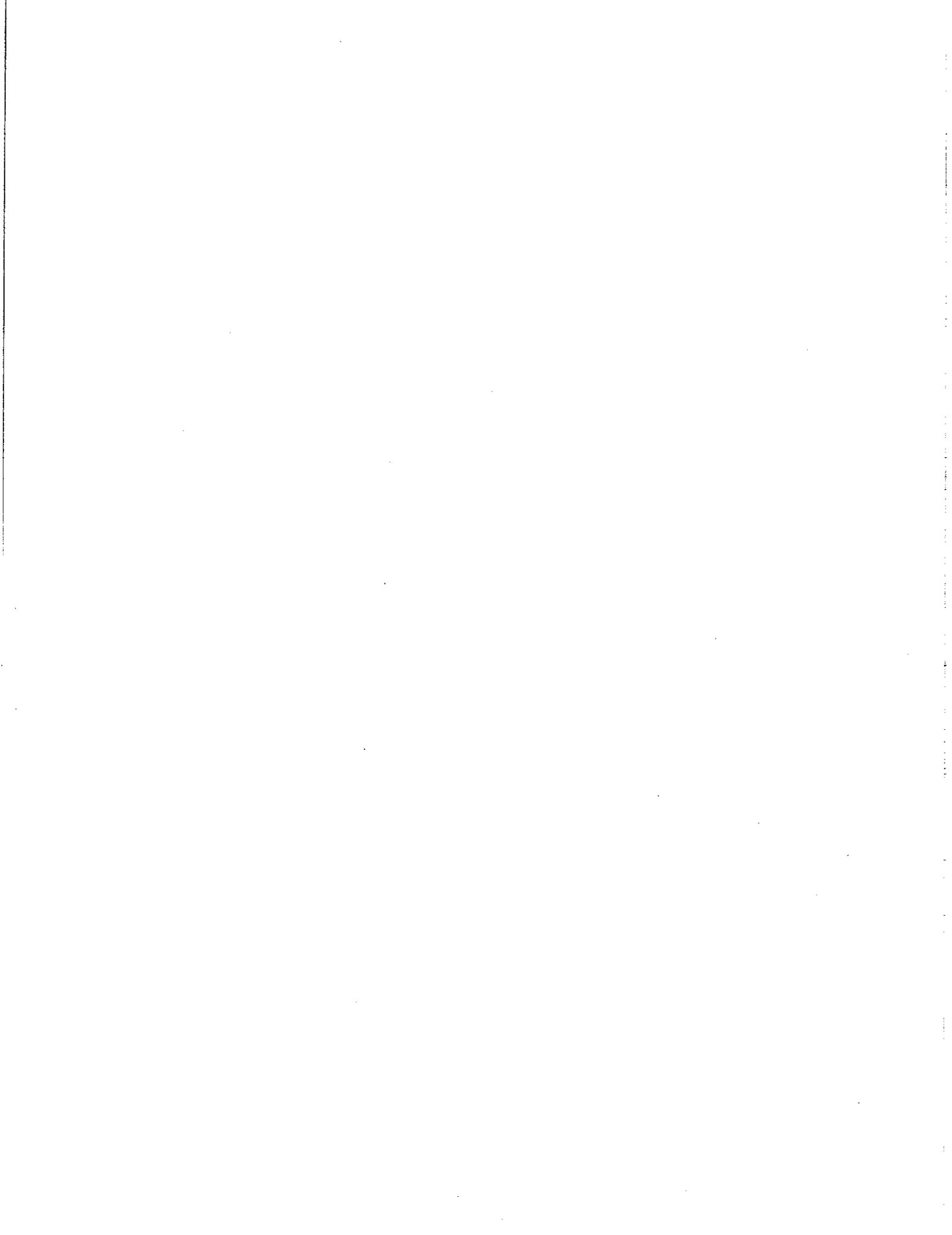

INTRODUCTION

1

CONGRATULATIONS!

Thank you for choosing PRONOVOST. We are confident this equipment will meet your requirements in terms of quality, performance and reliability.

This manual was prepared to assist you in the safe operation of your new Dump Trailer. It contains important information which will help you achieve excellent returns with your PRONOVOST Dump Trailer for years to come.

Please read this manual before operating your Trailer and keep it for future reference.

Before using this equipment, you or any other person who will be using it must familiarize yourself with the safety recommendations, the operating and safety instructions. Please read carefully and be sure to understand and follow all recommendations and procedures.

In this manual, the right and left sides are identified while standing at the rear end of the equipment and facing it.

If you require additional information on your Dump Trailer, please contact your PRONOVOST Dealer.

NOW take a moment to enter the model, serial number and the date of purchase of your Trailer in the space provided below.

When ordering parts from your Dealer, please refer to these numbers for a fast and efficient service. Use PRONOVOST parts for replacement.

The model and serial numbers are on the name plate shown on Fig. 1.

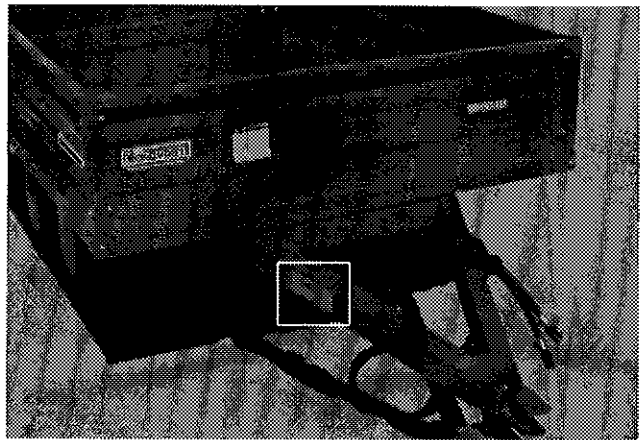

Figure 1

MODEL: _____

SERIAL NO: _____

DATE OF PURCHASE: _____

SAFETY

GENERAL SAFETY

2

WHEN YOU SEE THIS SYMBOL

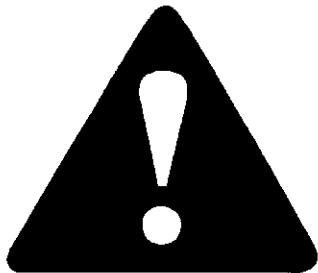

ATTENTION!

**BE ALERT
YOUR SAFETY IS INVOLVED**

This symbol "SAFETY ALERT" is used in this manual and on the safety decals on the Trailer. It warns you of the possibility of danger. Carefully read, understand and follow all safety recommendations before operating the equipment.

- 1) Careful operation is the best assurance against accidents. Carefully read this manual and follow all recommendations before operating this equipment. It is the owner's responsibility to make sure that anyone who will operate the Trailer will read this manual before operating the equipment.
- 2) Do not modify the equipment. Any non authorized modification may affect the efficiency and/or safety of the equipment.
- 3) Never operate the equipment with defective parts or if damaged in any way. Have it repaired before using it.
- 4) Make sure all fasteners are in place and properly secured or tightened. Refer to torque chart on page 18.

- 5) Hydraulic fluids under pressure can damage your skin. Do not use your hands to locate a leak.

SAFETY IN OPERATION

- 1) **WARNING!** Do not overload your trailer, do not exceed the load capacity indicated in the specifications on page 12.
- 2) Be sure there are no obstructions around the equipment and that no one stands near the equipment when in use.
- 3) Do not operate an engine in a confined or non ventilated area.
- 4) Do not perform any adjustments, cleaning, maintenance or repairs with the engine running on the towing vehicle. Preferably remove the key from the ignition.
- 5) Be careful when backing-up, make sure you have good visibility.
- 6) In the case of a Highway Service Trailer, make sure the suspension and lights are all functioning properly.
- 7) Do not forget to unlock the proper panel before dumping.
- 8) Always travel at a safe operating speed following regulations and common sense. In the case of agricultural service tires, follow the manufacturer's specified safe speed. The road speed should be such as to maintain full control over steering and braking.

SAFETY (cont'd)

SAFETY WITH MAINTENANCE

- 1) Perform maintenance according to recommendations contained in this manual.
- 2) If the trailer is hooked up to the tractor while performing maintenance work, make sure the engine is not running and preferably remove the ignition key.

SAFETY IN TRANSPORT

- 1) On public roads, use proper safety lights and check local regulations.

- 2) Be alert while driving on the road. Never carry passengers.

SAFETY IN STORAGE

- 1) If the trailer is to be stored for a certain period of time, install wooden blocks under the axles. **THIS WILL AVOID ANY ACCIDENTAL CRUSHING OF ANIMALS OR ANYONE WHO COULD CRAWL UNDER THE EQUIPMENT.**

2

DECALS

SAFETY DECALS

The safety decals are affixed wherever special safety precautions are indicated. Locate them on the equipment and read them carefully. If a decal is damaged, lost or illegible, install a new one. The following photos indicate where each one must be installed.

3

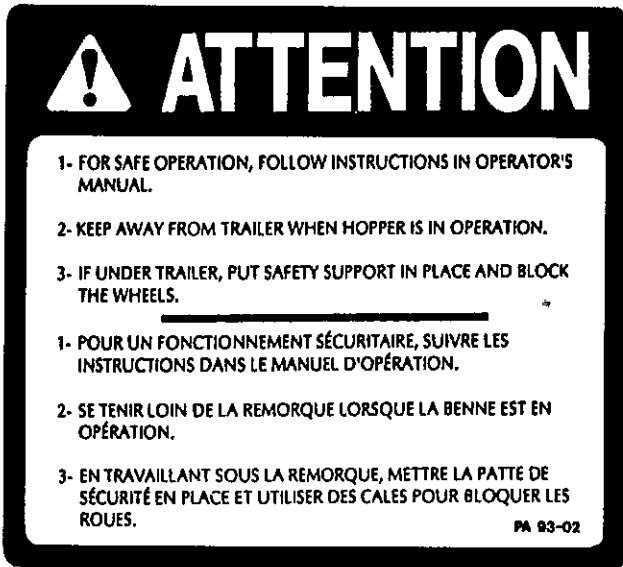

Figure 2
Decal A

Part no.: A110

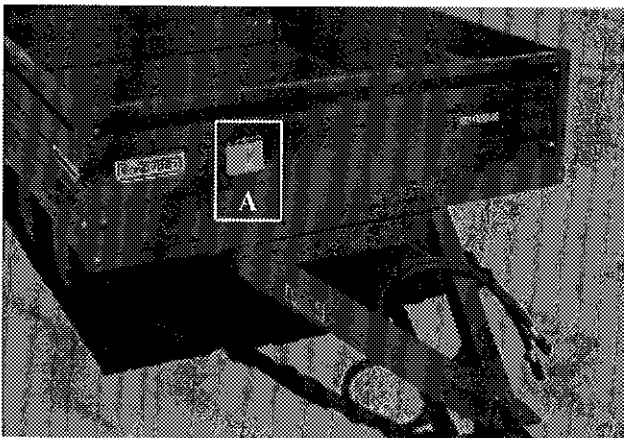

Figure 3



Figure 4
Decal B

Part no.: A103



Figure 5

MAINTENANCE DECALS

The maintenance decals indicate the points requiring lubrication. Refer to maintenance section for more details.

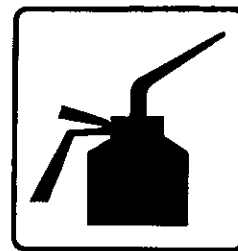

Figure 6

Part no.: A 105



Figure 7

Part no.: A 106

START-UP

BASIC START-UP PROCEDURES

- 1) Lubricate all grease fittings with a good quality multiuse grease.
- 2) Lubricate panel release mechanism, front and rear with good quality oil.
- 3) Adjust tire pressure to manufacturer's specifications.
- 4) Install wheels on hubs.
- 5) Install panels.
- 6) Install all hydraulic hoses and fittings compatible with your equipment.
- 7) Verify for adequate tightness of all fastening devices. Refer to torque chart on page 18.
- 8) Operate the hydraulic system a few times, raising and lowering the platform in order to remove any trapped air in the system. Then check the oil level in the tractor's hydraulic oil reservoir.
- 9) Do not forget to unlock the proper panel before dumping.

4

MAINTENANCE

- 1) Wipe off all grease fittings with a clean cloth before adding grease in order to avoid injecting dirt or sand.
- 2) Repair or replace damaged grease fittings.
- 3) Lubricate all grease fittings every 20 hours of operation.
- 4) Check all bolts on wheels after first 5 hours of operation and then every 50 hours of operation.
- 5) Lubricate panel release mechanism, front and rear, every 20 hours of operation.
- 6) Check tire pressure every 50 hours of operation, adjust according to manufacturer's recommendation indicated on the tires.
- 7) Open, clean and lubricate wheel bearings once a year.
- 8) Check all nuts and bolts once a year. If necessary use torque chart on page 18.

5

STORAGE

- 1) Store in a cool, dry place.
- 2) Install wooden blocks under the axles to keep the tires off the ground and cover them if left exposed to the sun.
- 3) Keep all piston rods in the retracted position. This will assure better protection against the elements.
- 4) Clean your trailer.
- 5) Thoroughly inspect all parts of the trailer. Replace or repair worn or defective parts.
- 6) Touch-up or repaint if necessary.
- 7) Lubricate all points before storage.

SPECIFICATIONS

SERVICE	AGRICULTURAL	AGRICULTURAL	HIGHWAY
MODEL	P-502	P-503	P-503H
Capacity	1 ton	1.5 tons	1.5 tons
Box (dimensions)	50" x 72" x 12G	50" x 72" x 12G	50" x 72" x 12G
Side panel (removable)	12" x 12G	12" x 12G	12" x 12G
Front/back panel (removable)	12"/14" x 12G	12"/14" x 12G	12"/14" x 12G
Platform height	22"	22"	22"
Overall length	7'6"	7'6"	7'6"
Overall width	4'5"	4'5"	4'5"
Overall height	3'0"	3'0"	3'0"
Free height / maximum lift	10"	10"	10"
Thread width	36 1/4"	36 1/4"	36 1/4"
Dumping angle (back)	45°	45°	45°
Dumping angle (2 sides)	--	--	--
Axle	Simple	Tandem	Tandem
Suspension	--	--	--
Grain door	--	--	--
Hubs	4 bolts	4 bolts	4 bolts
Hub capacity	1000 lbs	1000 lbs	1000 lbs
Spindles	1 1/4"	1 1/4"	1 1/4"
Wheels	2	4	4
Wheel dimensions	8.5" x 8"	8.5" x 8"	8.5" x 8"
Tires (standard)	18 x 8.5 x 8	18 x 8.5 x 8	18.5 x 8.5 x 8
Hitch: clevis/swivel	standard	standard	standard
Hitch: ball coupler	option	option	option
Electric brakes	--	--	--
Hydraulic brakes	--	--	--
Hitch weight (empty)	50 lbs	50 lbs	50 lbs
Total weight	530 lbs	565 lbs	565 lbs
Light system (12 V)	option	option	option
Oil volume required	--	--	--
Cylinder	1 double acting	1 double acting	1 double acting

8

Design and specifications subject to change without notice.

DUMP TRAILER P-503

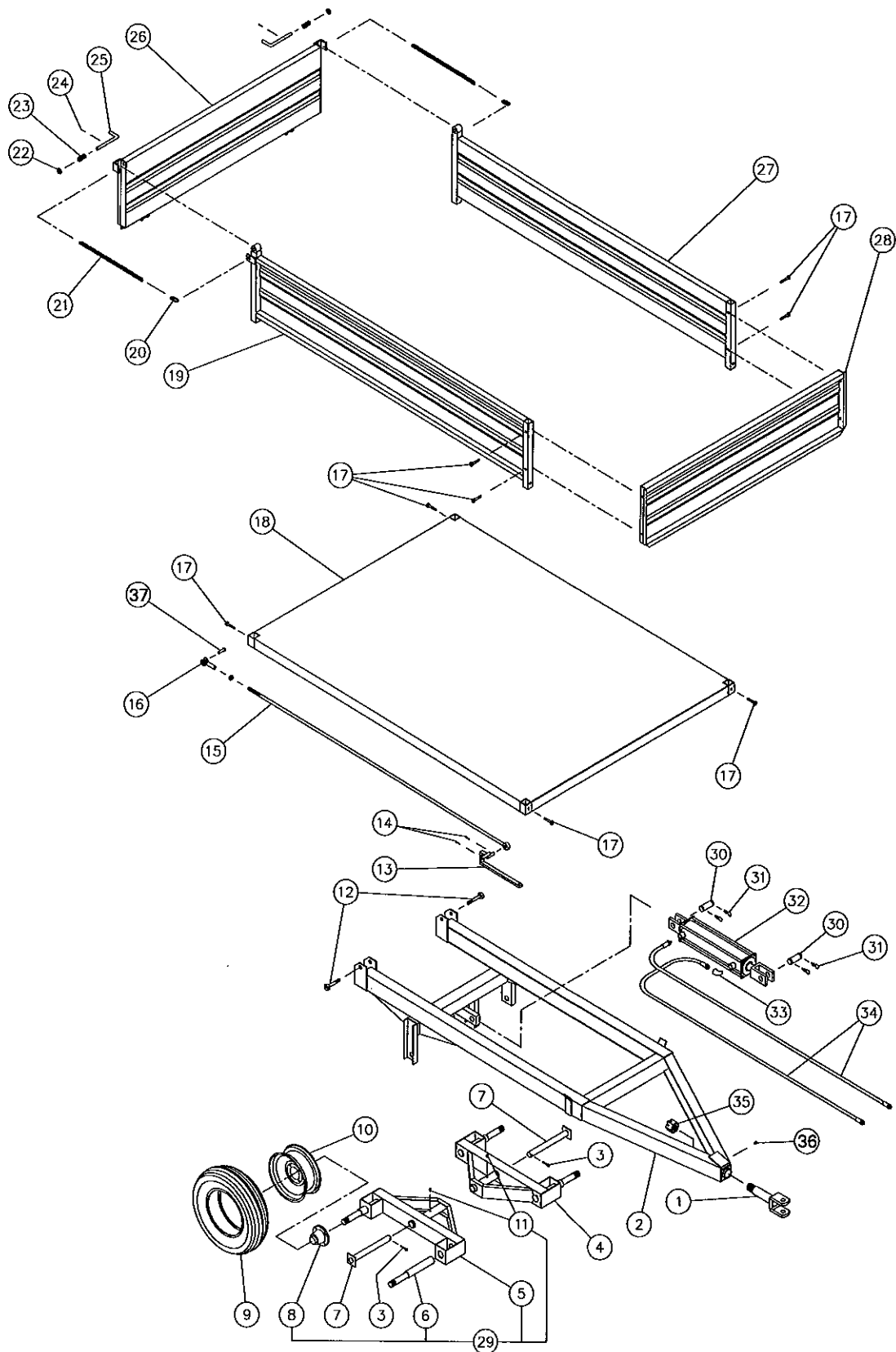

8

DUMP TRAILER P-503 (cont'd)

REF.	PART #	DESCRIPTION	QTY
1	53011	Swivel hitch	1
2	53010	Frame	1
3	Std.	Cotter pin 3/16" x 2" lg	2
4	53013-G	Left tandem frame	1
5	53013-D	Right tandem frame	1
6	53026	Spindle 1 1/4"	4
7	53009	Clevis pin 1" ø	2
8	53015	Hub # H-1000 complete (see details page 16)	4
9	PN-18858	Tire 18 x 8.5 x 8 4 ply	4
10	R874	Rim 8" x 7" - 4 holes	4
11	Std.	Grease fitting 1/4"-28 straight	2
12	Std.	Bolt 5/8" NC x 3 1/2" lg + nylon locknut	2
13	53046	Lever for rear panel locking mechanism	1
14	Std.	Cotter pin 1/8" x 1" lg	2
15	53047	Rod 1/2" for lock	1
16	51435	Clevis 1/2" NF + nut 1/2" NF	1
17	Std.	Bolt 3/8" NC x 2" lg + nut & lock washer	1
18	53048	Platform	1
19	53028	Right panel	1
20	53050	Quick link 1/4" x 1 3/4" lg	2
21	53049	Chain 7/32" x 18" lg	2
22	53051	Ring 9/16" i.d. x 1" o.d.	2
23	53052	Spring 7/8" o.d. x 2" lg	2
24	Std.	Roll pin 1/8" x 1 1/4" lg	2
25	53053	Pin	2
26	53030	Rear panel	1
27	53029	Left panel	1
28	53027	Front panel	1
29	53031-D	Right tandem assembly	1
NI*	53031-G	Left tandem assembly	1
30	53016	Clevis pin 1" ø	2
31	Std.	Hitch pin clip 3/16"	4
32	30TR12	Hydraulic cylinder 3" ø x 12" (see details page 17)	1
33	Std.	Elbow 1/2" 90°	1
34	53008	Hose 3/8" x 7'8" lg + 1 fitting 6U-108 + 1 fitting 6U-106	2
35	53012	Castle nut 1 1/4" NF	1
36	Std.	Grease fitting 1/4" - 28 straight	1
37	51436	Clevis pin 1/2" x 1 3/4"lg	1

*NI = Not illustrated

8

MANUAL PUMP #53056 (106.3.20)

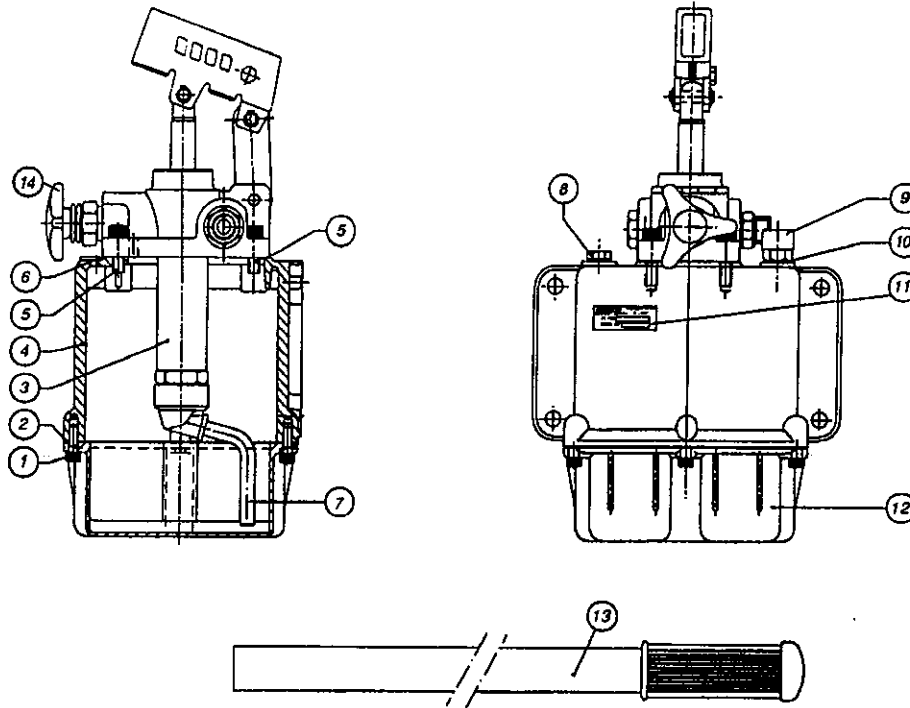

REF.	PART #	CODE #	DESCRIPTION	QTY
1	53032	502.2.441	Screw for reservoir mounting	8
2	53033	507.3.182	Reservoir gasket	1
3	53034	106.4.29	PMSS 45 Hand-Pump only (no body)	1
4	53035	514.3.89	Pump main body	1
5	53036	502.3.566	Screw M8 x 25	4
6	53037	507.3.208	Pump gasket	1
7	53038	541.4.36	Suction pipe for 3 lt. reservoir	1
8	53039	540.2.49	Oil filler plug	1
9	53040	118.10.106	Breather cap	1
10	53041	116.9.158	Aluminum washer	1
11	53042	513.13.963	Name plate	1
12	53043	514.5.78	Reservoir (3 lt.)	1
13	53044	106.0.78	Lever PM 45	1
14	53057	500.1.99	Relief valve knob	1
NI*	53045	106.900.51	Gasket kit	1
NI*	PHM 3003		Pump #53056 with installation hardware	1

*NI = Not illustrated

8

HUB H1000

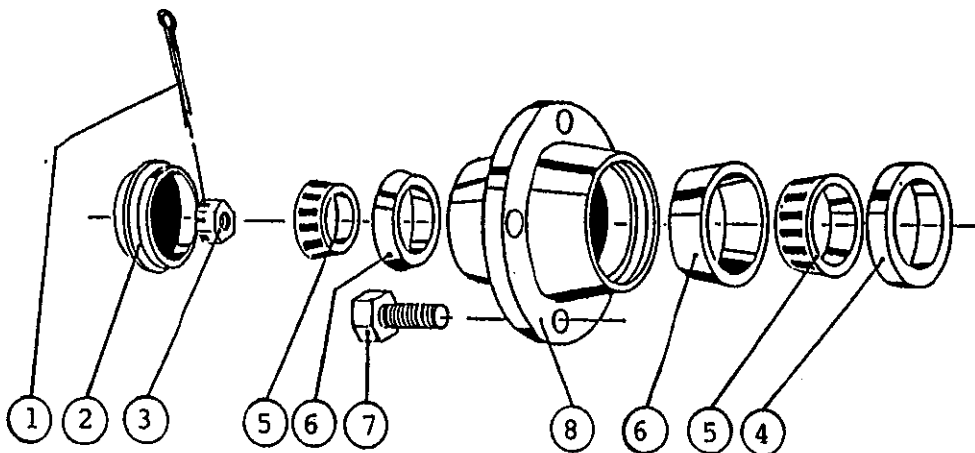

REF.	PART #	DESCRIPTION	QTY
1	Std.	Cotter pin 3/16" x 1 1/2"	1
2	53019	Dust cap 1.973 dia.	1
3	51529	Castle nut 1" NF noir	1
4	53021	Oil seal no. CR523696	1
5	53022	Roller bearing Timken: cone no. L44643	2
6	53023	Roller bearing Timken: cup no. L44610	2
7	53024	Rim screw 1/2"	4
8	53025	Hub only H1000	1

8

CYLINDER 30TR12

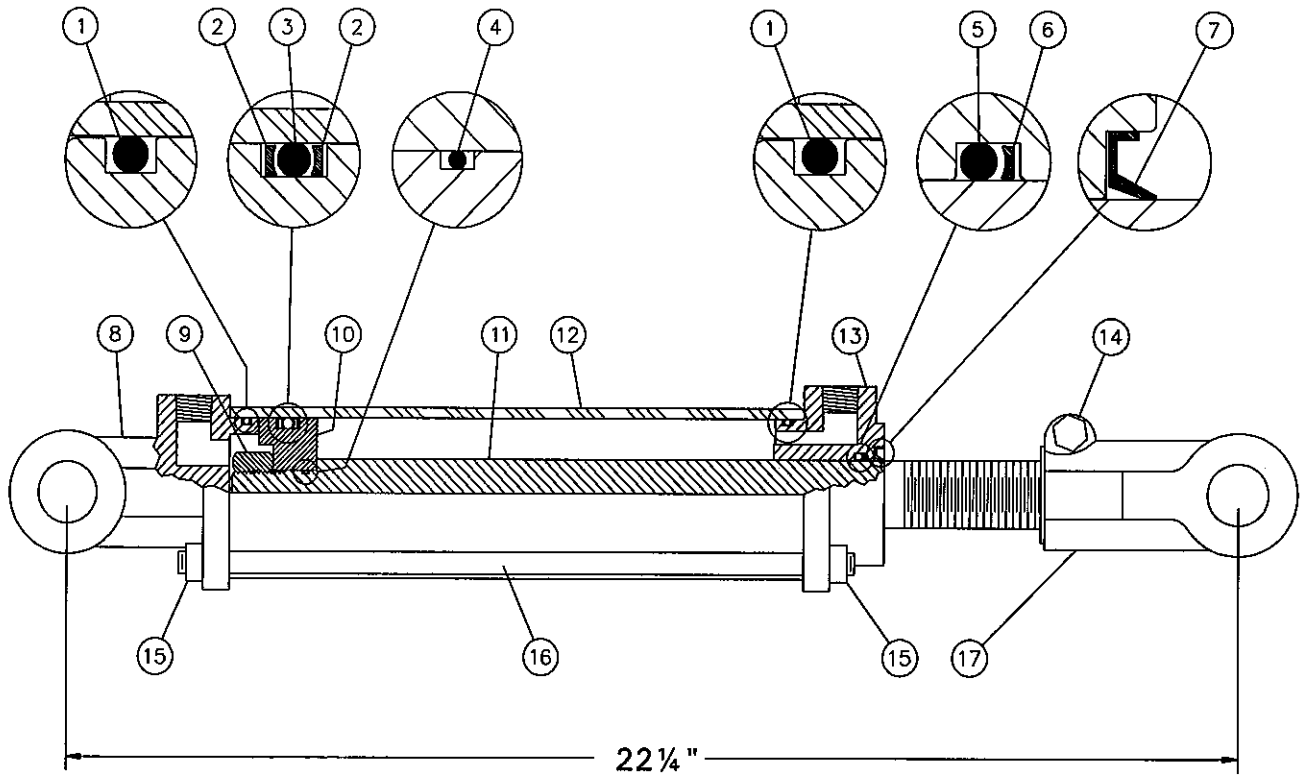







REF.	PART #	DESCRIPTION	QTY
1	See RK30TR	O-ring	2
2	See RK30TR	Back-up ring	2
3	See RK30TR	O-ring	1
4	See RK30TR	O-ring	1
5	See RK30TR	O-ring	1
6	See RK30TR	Back-up ring	1
7	See RK30TR	Wiper	1
8	492402	Yoke (for 3" tube)	1
9	Std.	Nut 3/4" NF	1
10	492432	Piston 3" ø	1
11	492042	Piston rod 1 1/4"	1
12	491742	Cylinder body 3" ø	1
13	492440	Cylinder head (for 3" tube)	1
14	Std.	Bolt 3/8" NC x 2 1/4" + nut	1
15	Std.	Nut 3/8" NC	8
16	Std.	Threaded rod 3/8" NC	4
17	458600	Yoke (for 1 1/4" rod)	1
NI*	8183	Pin 1" ø + cotter pin	2
NI*	RK30TR	Repair kit for cylinder 3" (includes # 1, 2, 3, 4, 5, 6, & 7)	1

8





*NI = Not illustrated

TORQUE CHART

TORQUE SPECIFICATION TABLE

Thread UNC and UNF		Grade 2 				Grade 5   				Grade 8*   			
Bolt size		Torque				Torque				Torque			
Inches	mm	Pound feet		Newton meters		Pound feet		Newton meters		Pound feet		Newton meters	
		min.	max.	min.	max.	min.	max.	min.	max.	min.	max.	min.	max.
1/4	6.35	5	6	6.8	8.13	9	11	12.2	14.9	12	15	16.3	30.3
5/16	7.94	10	12	13.6	16.3	17	20.5	23.1	27.8	24	29	32.5	39.3
3/8	9.53	20	23	27.1	31.2	35	42	47.5	57.0	45	54	61.0	73.2
7/16	11.11	30	35	40.7	47.4	54	64	73.2	86.8	70	84	94.9	113.9
1/2	12.70	45	52	61.0	70.5	80	96	108.5	130.2	110	132	149.2	179.0
9/16	14.29	65	75	88.1	101.6	110	132	149.2	179.0	160	192	217.0	260.4
5/8	15.88	95	105	128.7	142.3	150	180	203.4	244.1	220	264	298.3	358.0
3/4	19.05	150	185	203.3	250.7	270	324	366.1	439.3	380	456	515.3	618.3
7/8	22.23	160	200	216.8	271.0	400	480	542.4	650.9	600	720	813.6	976.3
1	25.40	250	300	338.8	406.5	580	696	786.5	943.8	900	1080	1220.4	1464.5
1 1/8	25.58	-	-	-	-	800	880	1084.8	1193.3	1280	1440	1735.7	1952.6
1 1/4	31.75	-	-	-	-	1120	1240	1518.7	1681.4	1820	2000	2467.9	2712.0
1 3/8	34.93	-	-	-	-	1460	1680	1979.8	2278.1	2380	2720	3227.3	3688.3
1 1/2	38.10	-	-	-	-	1940	2200	2630.6	2983.2	3160	3560	4285.0	4827.4

* Thick nuts must be used with grade 8 bolts.

Size of screw	Thread	Pitch (mm)	Grade 4T  				Grade 7T 				Grade 8T  			
			Torque		Torque		Torque		Torque		Torque		Torque	
			Pound feet		Newton meters		Pound feet		Newton meters		Pound feet		Newton meters	
			min.	max.	min.	max.	min.	max.	min.	max.	min.	max.	min.	max.
M6	UNC	1.00	3.6	5.8	4.9	7.9	5.8	9.4	7.9	12.7	7.2	10	9.8	13.6
M8	UNC	1.25	7.2	14	9.8	19	17	22	23	29.8	20	26	27.1	35.2
M10	UNC	1.5	20	25	27.1	33.9	34	40	46.1	54.2	38	46	51.5	62.3
M12	UNC	1.75	28	34	37.9	46.1	51	59	69.1	79.9	57	66	77.2	89.4
M14	UNC	2.0	49	56	66.4	75.9	81	93	109.8	126	96	109	130.1	147.7
M16	UNC	2.0	67	77	90.8	104.3	116	130	157.2	176.2	129	145	174.8	196.5
M18	UNC	2.0	88	100	119.2	136	150	168	203.3	227.6	175	194	237.1	262.9
M20	UNC	2.5	108	130	146.3	176.2	186	205	252	277.8	213	249	288.6	337.4
M8	UNF	1.0	12	17	16.3	23	19	27	25.7	36.6	22	31	29.8	42
M10	UNF	1.25	20	29	27.1	39.3	35	47	47.4	63.7	40	52	54.2	70.5
M12	UNF	1.25	31	41	42	55.6	56	68	75.9	92.1	62	75	84	101.6
M14	UNF	1.5	52	64	70.5	86.7	90	106	122	143.6	107	124	145	168
M16	UNF	1.5	69	83	93.5	112.5	120	138	162.6	187	140	158	189.7	214.1
M18	UNF	1.5	100	117	136	158.5	177	199	239.8	269.6	202	231	273.7	313
M20	UNF	1.5	132	150	178.9	203.3	206	242	279.1	327.9	246	289	333.3	391.6

Use the above torques when special torque is not given.

NOTE: These values apply to fasteners as received from supplier, dry, or when lubricated with normal engine oil. They do not apply if extreme pressure lubricants are used.

WARRANTY

PRONOVOST warrants this product to the initial purchaser for the period of one year from the date of purchase against defects in materials and workmanship.

We will replace or repair defective parts free of charge if they are returned to our plant in St-Tite, Quebec, Canada.

Transportation charges are the responsibility of the customer. This warranty is not transferable.

Hydraulic cylinders are covered by the manufacturer of these items.

All PRONOVOST spare parts purchased are covered by a three (3) month warranty.

This warranty becomes void and nul if the equipment is modified, breaks down as the result of an accident, is not operated according to manufacturer's recommendations, damaged by negligence or if maintenance has not been carried out as specified.

Our obligation is limited to the replacement or repair of the defective part. PRONOVOST accepts no responsibility for direct or indirect consequential damages of any kind.

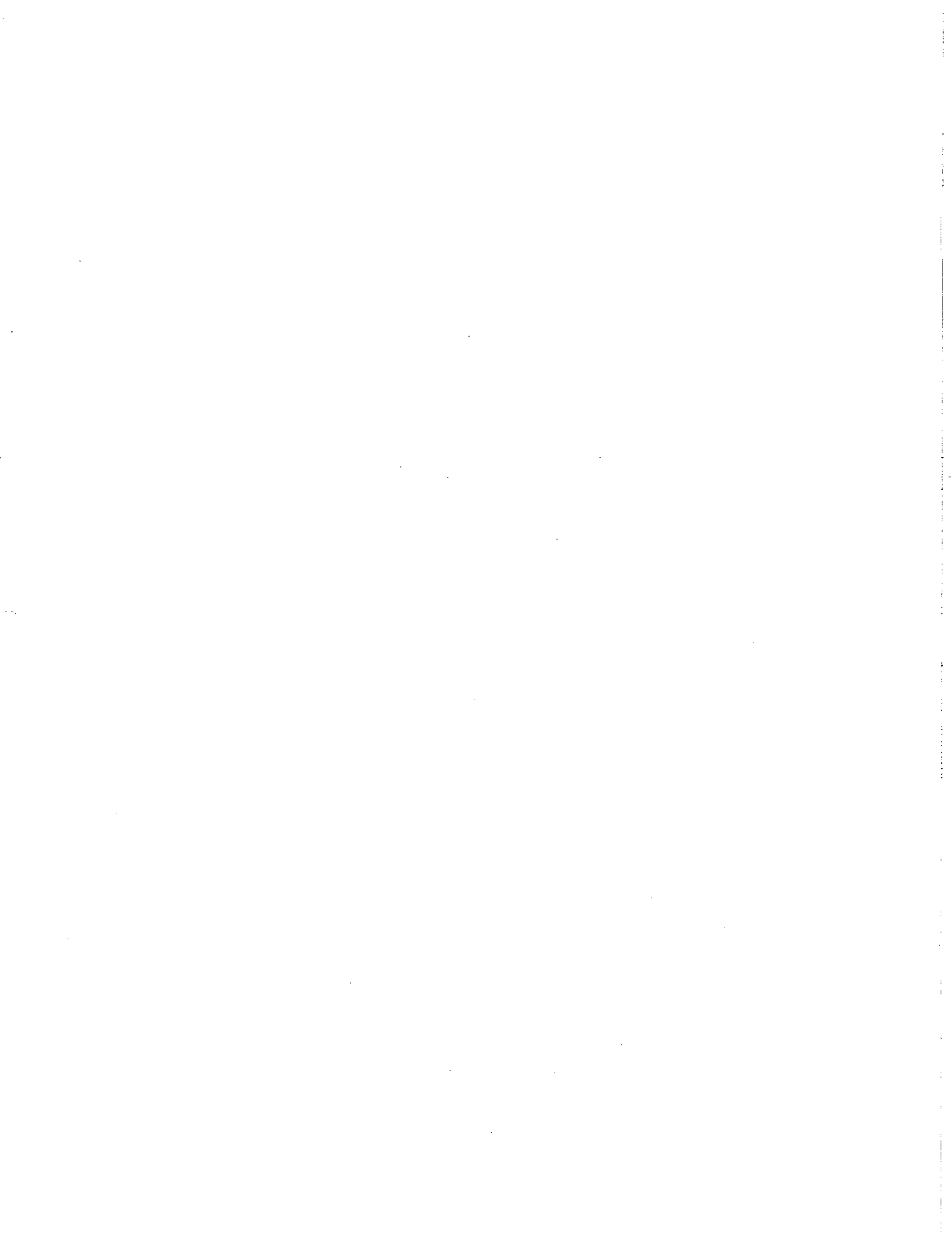



Ce manuel est aussi disponible en français.
Veuillez téléphoner.



LES MACHINERIES PRONOVOST INC.
260, route 159,
Saint-Tite, Quebec, Canada, GOX 3H0
Tel.: (418) 365-7551, Fax: (418) 365-7954