

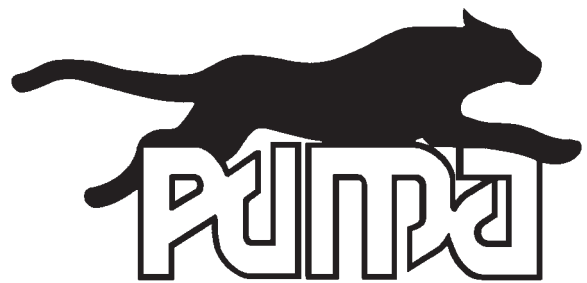

**OPERATOR'S / PARTS  
MANUAL**



***PUMA Hydraulic snowblower***

**Models**

**PUMA-54H**

**PUMA-64H**

**PUMA-72H**

**PUMA-74H**

VISIT OUR WEBSITE



[www.pronovost.qc.ca](http://www.pronovost.qc.ca)

Copyright © Les Machineries Pronovost Inc., 2005

All rights reserved.  
Printed in Canada.

---



---

# **TABLE OF CONTENTS**

---

<b>Section</b>	<b>Item</b>	<b>Page</b>
<b>1</b>	<b>Introduction .....</b>	<b>5</b>
<b>2</b>	<b>Safety .....</b>	<b>6</b>
	General Safety .....	6
	Safety in operation .....	6
	Safety with Maintenance .....	7
	Safety in transport .....	7
	Safety in storage .....	7
<b>3</b>	<b>Decals .....</b>	<b>8</b>
	Safety Decals .....	8
	Maintenance Decals .....	9
<b>4</b>	<b>Maintenance .....</b>	<b>10</b>
<b>5</b>	<b>Storage .....</b>	<b>11</b>
<b>6</b>	<b>Specifications .....</b>	<b>12</b>
<b>7</b>	<b>Parts List .....</b>	<b>13</b>
	Snowblower PUMA-54H PUMA-64H PUMA-72H .....	13
	Snowblower PUMA-74H .....	15
	Manual Chute Kit MD-4872 .....	17
	Manual Chute Kit MD-74 .....	18
	Hydraulic Chute Kit HRD-4872 .....	19
	Hydraulic Chute Kit HRD-74 .....	20
	Quick attach .....	21
	Hydraulic motors .....	21
	Mounting kit for hydraulic motor .....	21
	Electric valve kit KVE-5474 .....	21
	Hydraulic pump on P.T.O. PTP24G .....	21
	Hydraulic circuit: Motor without KVE-5474 option .....	24
	Hydraulic circuit: Motor with KVE-5474 option .....	25
	Electric circuit for KVE-5474 option .....	27
	Hydraulic circuit: for hydraulic pump on P.T.O. PTP24G .....	29
	Gear Box 6550 .....	30
	Gear Box 6451 .....	31
	Gear Box 8251 .....	32
	Cylinder 25TR04 .....	33
	Cylinder 25TR08 .....	34
	Hydraulic motor MLHS .....	35
	Hydraulic motor MLHT .....	36
<b>8</b>	<b>Torque chart .....</b>	<b>37</b>
<b>9</b>	<b>Warranty .....</b>	<b>38</b>



---

---

# INTRODUCTION

---

---

Your Snowblower was carefully designed and we are confident it will meet your requirements in terms of quality, performance and reliability.

This manual was prepared to assist you in the safe operation of your new Snowblower. It contains important information which will help you achieve excellent returns with your Snowblower.

Please read this manual completely before operating your Snowblower and keep it for future reference.

Before starting the machine, you or any other person who will be operating the Snowblower must familiarize yourself with the safety recommendations and the operating instructions. Please read carefully and be sure to understand and follow all recommendations and procedures.

In this manual, the right and left sides are identified as shown on Figure 1.

If you require additional information on your Snowblower, please contact your PRONOVOST Dealer.

**NOW** take a moment to enter the model, serial number and the date of purchase of your Snowblower in the space provided.

When ordering parts from your Dealer, please refer to these numbers for a fast and efficient service. Use PRONOVOST parts for replacement.

The model and serial numbers are on the name plate shown on Fig. 1.

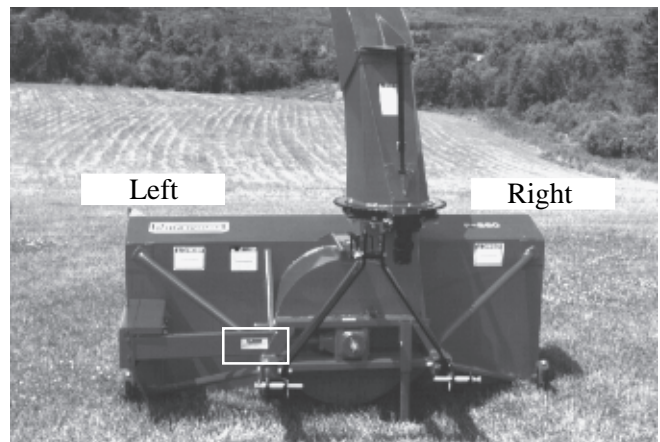

Figure 1

MODEL: \_\_\_\_\_ 

SERIAL NO.: \_\_\_\_\_ 

DATE OF PURCHASE: \_\_\_\_\_ 

---

---

# ***SAFETY***

---

## ***GENERAL SAFETY***

### **WHEN YOU SEE THIS SYMBOL**



**ATTENTION!**

**BE ALERT  
YOUR SAFETY IS INVOLVED**

This symbol «**SAFETY ALERT**» is used in this manual and on the safety decals on the Snowblower. It warns you of the possibility of danger. Carefully read, understand and follow all safety recommendations before operating the Snowblower.

- 1) Careful operation is the best assurance against accidents. Carefully read this manual and follow all recommendations before operating your Snowblower. It is the owner's responsibility to make sure that anyone who will operate the Snowblower will read this manual before operating the equipment.
- 2) Familiarize yourself with all controls and always be ready to stop the Snowblower quickly in case of emergency.
- 3) Never let a child operate the Snowblower.
- 4) Do not modify the Snowblower. Any non authorized modification may affect the efficiency and/or safety of the equipment.
- 5) Never operate the Snowblower with defective parts or if damaged in any way. Have it repaired before operating.
- 6) Make sure all fasteners are in place and properly secured or tightened. Refer to torque chart on page 37.
- 7) Avoid wearing loose fitting clothing when working with the Snowblower. These could get entangled in moving parts of the equipment and cause accidents.

- 8) Prolonged exposure to noise may hamper hearing. Protect yourself by wearing adequate protection devices.
- 9) Hydraulic fluids under pressure can damage your skin. Do not use your hands to locate a leak.
- 10) Before the beginning of the snow season, inspect all areas where the Snowblower will be used and remove any object which may cause an accident and/or damage the equipment.
- 11) Never operate your Snowblower in poor visibility or without proper lighting conditions.

## ***SAFETY IN OPERATION***

- 1) Never raise the snowblower more than 5' to avoid tilting tractor forward.
- 2) Be sure there are no obstructions around the equipment and that no one stands near the equipment when in operation.
- 3) Do not operate an engine in a confined or non ventilated area.
- 4) Do not perform any adjustments, cleaning, maintenance or repairs with the engine running. The engine must be stopped and the P.T.O. disengaged. Preferably remove the key from the ignition.
- 5) Wear adequate clothing when working in cold or windy conditions.
- 6) Before starting-up the Snowblower, make sure the auger and drum areas are free of ice.
- 7) Place control handle in neutral position before starting engine.
- 8) Keep hands, feet and clothing away from moving parts of the Snowblower. Stay away from the discharge chute.
- 9) Before unplugging the chute, always disengage the P.T.O., stop the engine and relieve all hydraulic pressures.

---

---

## ***SAFETY (cont'd)***

---

- 10) Do not operate in excessive inclined conditions. Be careful when turning in slopes.
- 11) Never operate your Snowblower with missing guards or without protective devices in place.
- 12) Do not operate your Snowblower near buildings, windows or other vehicles without prior and proper adjustment of the chute deflector.
- 13) Never aim discharge chute towards people or animals. This may cause serious injuries.
- 14) Always reduce operating speed in slippery conditions.
- 15) Be careful when backing-up, make sure you have good visibility.
- 16) Always be on the lookout for objects which may enter the Snowblower.
- 17) If undue vibrations are felt, disengage the oil motor., stop the motor and look for the cause of the vibration. Vibration is usually the indication of a problem.
- 18) At the end of the operation, disengage the oil motor, lower the Snowblower, put transmission in neutral, apply parking brake, stop engine and remove the key from the ignition.

### ***SAFETY WITH MAINTENANCE***

- 1) Perform the Snowblower maintenance according to recommendations contained in this manual.
- 2) Stop engine and relieve all hydraulic pressures before doing inspection, maintenance or repairs.
- 3) Never perform any work under the Snowblower while it is supported only by the tractor's hydraulic system. It must be completely supported by wooden blocks or other safe means.

### ***SAFETY IN TRANSPORT***

- 1) On public roads, use proper safety lights and check local regulations.
- 2) Be alert while driving on the road. Never carry passengers.
- 3) Always disengage the oil motor while moving from one area of work to another.
- 4) Never exceed the speed that permits full steering and braking control at all times.
- 5) Be careful while backing up, make sure you have good visibility.

### ***SAFETY IN STORAGE***

- 1) Provide adequate supports to prevent any accidental overturning of the Snowblower.
- 2) Do not let children play in the area where the Snowblower is stored.

# DECALS

## SAFETY DECALS

The safety decals are affixed wherever special safety precautions are indicated. Locate them on the machine and read them carefully. If a decal is damaged, lost or illegible, install a new one. Each decal is shown and identified with a part number.

### **ATTENTION**

- 1- FOR SAFE OPERATION, FOLLOW OPERATING INSTRUCTIONS IN OPERATOR'S MANUAL.
- 2- KEEP HANDS, FEET AND CLOTHINGS AWAY FROM POWER DRIVEN PARTS.
- 3- STOP ENGINE BEFORE LEAVING THE EQUIPMENT.
- 4- MACHINE HAS TO BE COMPLETELY STOPPED BEFORE STARTING TO ADJUST OR LUBRICATE.
- 5- KEEP PEOPLE AND PETS AT SAFE DISTANCE FROM MACHINE.
- 6- KEEP ALL GUARDS AND SHIELDS IN PLACE.

---

- 1- POUR UN FONCTIONNEMENT SÉCURITAIRE SUIVRE LES INSTRUCTIONS DANS LE MANUEL D'OPÉRATION.
- 2- GARDER LES MAINS, PIEDS ET VÊTEMENTS ÉLOIGNÉS DES ÉLÉMENTS MOBILES OU ROTATIFS.
- 3- AVANT DE QUITTER LA MACHINE ARRÊTER LE MOTEUR.
- 4- ARRÊTER COMPLÈTEMENT LA MACHINE POUR EFFECTUER L'ENTRETIEN ET L'AJUSTEMENT.
- 5- GARDER LES GENS ET LES ANIMAUX À UNE DISTANCE SÉCURITAIRE.
- 6- GARDER TOUS LES ÉCRANS PROTECTEUR EN PLACE.

PA 93-01

Figure 2  
Part no.: A102

### **DANGER**

TO AVOID SERIOUS INJURIES, KEEP CLEAR OF EQUIPMENT WHILE IN OPERATION.

---

POUR ÉVITER DES BLESSURES GRAVES SE TENIR LOIN DE CET ÉQUIPEMENT LORSQU'IL EST EN MARCHÉ.

PD 93-03

Figure 3  
Part no.: A101

### **ATTENTION**

**PEUT AFFECTER L'EFFICACITÉ OU ENDOMMAGER LA POMPE**

LE BOYAU DE SUCCION DOIT ÊTRE ASSEMBLÉ DE FAÇON À CE QU'IL NE SOIT PAS Plié À MOINS DE 8 POUCES DE RAYON DANS TOUTES LES POSITIONS.

**MAY AFFECT EFFICIENCY OR DAMAGE THE PUMP.**

THE SUCTION HOSE MUST BE ASSEMBLED AS SHOWN ABOVE. BEND IN HOSE MUST NOT HAVE A RADIUS INFERIOR TO 8 INCHES.

190-06171

Figure 4  
Part no.: 190-06171



---

---

# *DECALS*

---

## *MAINTENANCE DECALS*

The maintenance decals indicate the points requiring lubrication. Refer to maintenance section for more details.



Figure 5

Part no.: A104



Figure 6

Part no.: A 106

---

---

## ***MAINTENANCE***

---

- 1) Wipe off all grease fittings with a clean cloth before adding grease in order to avoid injecting dirt and sand.
- 2) Repair or replace damaged grease fittings.
- 3) Lubricate all grease fittings every 10 hours of operation.
- 4) Oil drive chain every 8 hours of operation.
- 5) Check oil level in gear box once a month. If necessary add oil.
- 6) Check tension of drive chain every 25 hours of operation and adjust if necessary.
- 7) Check for tightness of bearing collars every 50 hours of operation.
- 8) Change gearbox oil once a year. Use gear box oil S.A.E. W90 rated API, class GL-5.
- 9) Check all nuts and bolts once a year. If necessary use torque chart on page 37.

---

---

## ***STORAGE***

---

- 1) Store the Snowblower in a cool, dry place.
- 2) Support the Snowblower with wooden blocks.
- 3) Keep all piston rods in the retracted position. This will assure better protection against the elements.
- 4) Clean your Snowblower.
- 5) Thoroughly inspect all parts of the Snowblower. Replace or repair worn or defective parts.
- 6) Touch-up or repaint if necessary.
- 7) Lubricate all points before storage.

---

## ***SNOWBLOWER SPECIFICATIONS***

---

<b>MODEL</b>	<b>PUMA-54H</b>	<b>PUMA-64H</b>	<b>PUMA-72H</b>	<b>PUMA-74H</b>
Working width	54"	64"	72"	74"
Cutting height	24½"			29"
Impeller diameter	20"			22"
Depth of drum	6"			8"
Impeller blades	4			4
Size of impeller shaft	1"			1 9/16"
Impeller RPM	540			540
Main auger diameter	16"			16"
Drive chain	50			60
Hitch category	1			1 & 2
Chute rotation on UHMW	Standard			Standard
Adjustable skid shoes	Standard			Standard
Manual chute rotation kit <b>opt.</b>	<b>MD-4872</b>			<b>MD-74</b>
Hydraulic chute rotation kit <b>opt.</b>	<b>HRD-4872</b>			<b>HRD-74</b>
Cylinder. for hyd. chute rotation <b>opt.</b>	<b>25TR04</b>			<b>25TR08</b>
Cylinder. for deflector hyd. control <b>opt.</b>	<b>25TR04</b>			<b>25TR08</b>
App. weight with mounting attachment	492 lbs	512 lbs	529 lbs	810 lbs

Design and specifications subject to change without notice.

# SNOWBLLOWERS PUMA-54H PUMA-64H PUMA-72H

170-03563

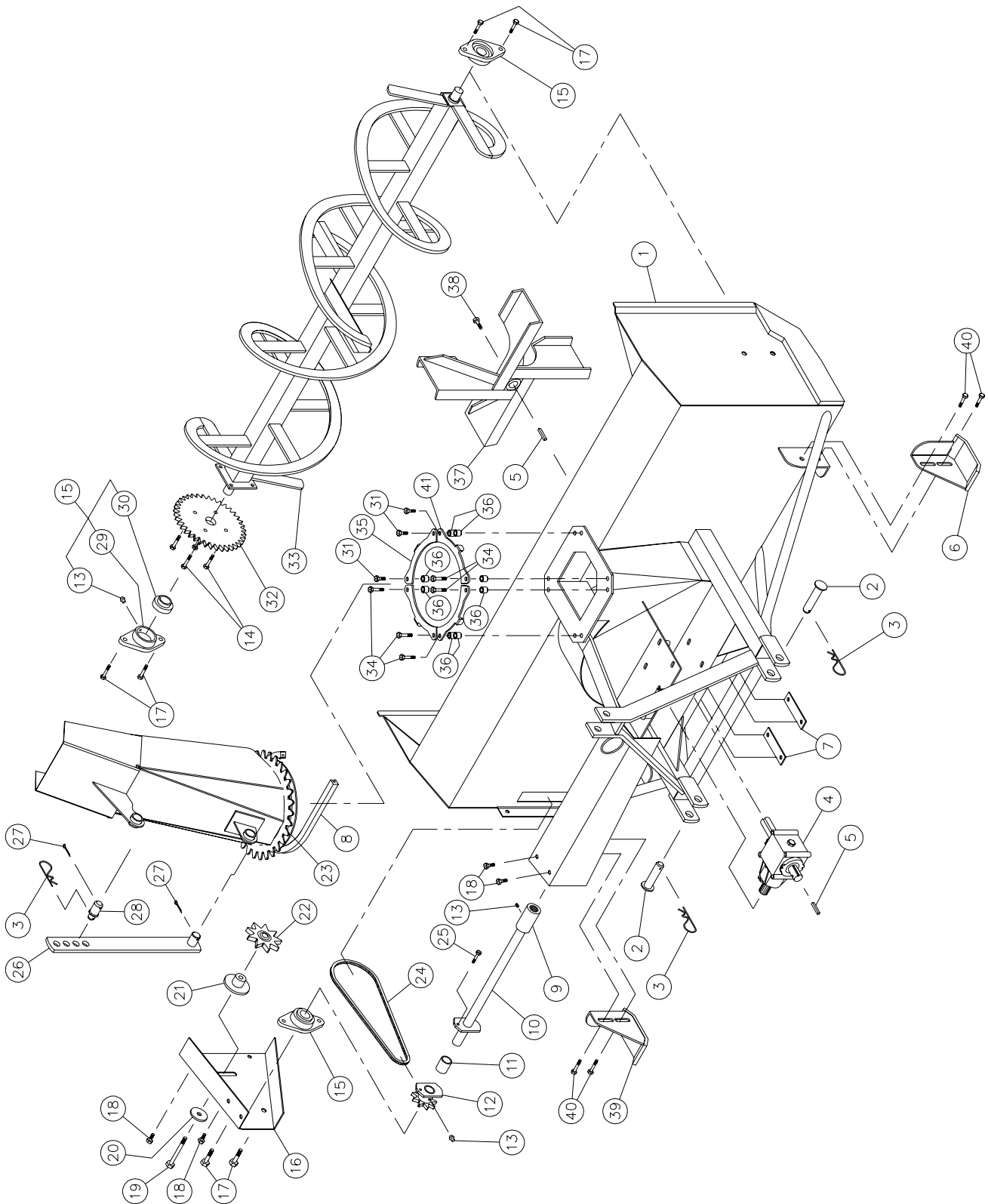

# SNOWBLOWERS PUMA-54H PUMA-64H PUMA-72H (cont'd)

REF.	PART #	DESCRIPTION	QTY		
			54H	64H	72H
1	120-00543	Frame 54" .....	1	-	-
1	120-00553	Frame 64" .....	-	1	-
1	120-04282	Frame 72" .....	-	-	1
2	110-03331	Pin category 1 .....	2	2	2
3	Std.	Hitch pin clip 5/32" .....	3	3	3
4	6550	Gear box 1" ø x 1-15 splines .....	1	1	1
5	140-03871	Key 1/4" x 1/4" x 1 5/8" lg .....	2	2	2
6	110-15341	Skid shoe (right side) .....	1	1	1
7	140-11011	Back plate .....	2	2	2
8	190-04081	U-shaped UHMW 32 9/16" lg .....	1	1	1
9	6565	Splined adaptor 1"-15 .....	1	1	1
10	110-02821	Auger drive shaft 21" lg overall (including #9) .....	1	-	-
10	110-02971	Auger drive shaft 26" lg overall (including #9) .....	-	1	-
10	110-20981	Auger drive shaft 30" lg overall (including #9) .....	-	-	1
11	6566	Bushing 1" i.d. x 1 1/8" o.d. x 1 1/2" lg .....	1	1	1
12	6567	Sprocket # 50 + shearplate (including # 11 and # 13) .....	1	1	1
13	Std.	Grease fitting 1/4"-28 straight .....	5	5	5
14	300-36280	Bolt 3/8" NC x 1 1/4" lg + two-way locknut .....	4	4	4
15	UCFLD205-16	Bearing 1"ø + flange .....	3	3	3
16	130-03301	Chain guard .....	1	1	1
17	300-40250	Bolt 1/2" NC x 1" lg + nylon locknut (thin) .....	6	6	6
18	300-36250	Bolt 3/8" NC x 1" lg + nylon locknut .....	4	4	4
19	300-40400	Bolt 1/2" NC x 3" lg + nylon locknut .....	1	1	1
20	378-40340	Flat washer 1/2" d.i. x 2" d.e. ....	1	1	1
21	110-07732	Idler .....	1	1	1
22	6604	Idler sprocket #50 .....	1	1	1
23	110-02892	Chute .....	1	1	1
24	190-00501	Chain #50 x 50 5/8" lg .....	1	1	1
24	26A50	Connecting link #50 .....	1	1	1
24	59-50	Offset link #50 .....	1	1	1
25	Std.	Shear bolt 1/4" NC x 1" lg grade 2 + nylon locknut .....	1	1	1
26	110-02981	Chute adjusting bar .....	1	1	1
27	Std.	Cotter pin 5/32" x 1 1/2" .....	2	2	2
28	150-00641	Pin for chute adjusting bar .....	1	1	1
29	FLD205	Flange .....	3	3	3
30	UC205-16	Bearing 1" ø .....	3	3	3
31	300-36325	Bolt 3/8" NC x 1 3/4" lg + nylon locknut & flat washer .....	2	2	2
32	6288	Sprocket 50A36 T 1" ø .....	1	1	1
33	110-02941	Auger PUMA-54 .....	1	-	-
33	110-02961	Auger PUMA-64 .....	-	1	-
33	110-20991	Auger PUMA-72 .....	-	-	1
34	300-36340	Bolt 3/8" NC x 2" lg + nylon locknut + flat washer .....	6	6	6
35	130-18392	Chute retaining bracket .....	3	3	3
36	160-07371	Spacer 11/16" o.d. x 7/16" i.d. x 5/8" lg .....	8	8	8
37	110-02871	Impeller 6" x 20" ø 4 blades T 1" ø .....	1	1	1
38	329-34280	Impeller cap screw 5/16" x 1 1/4" lg + lock washer .....	1	1	1
39	110-15342	Skid shoe (left side) .....	1	1	1
40	300-38280	Bolt 7/16" NC x 1 1/4" lg + nylon locknut + flat washer .....	4	4	4
41	130-18393	Chute retaining bracket .....	1	1	1

# SNOWBLOWER PUMA-74H

170-03573

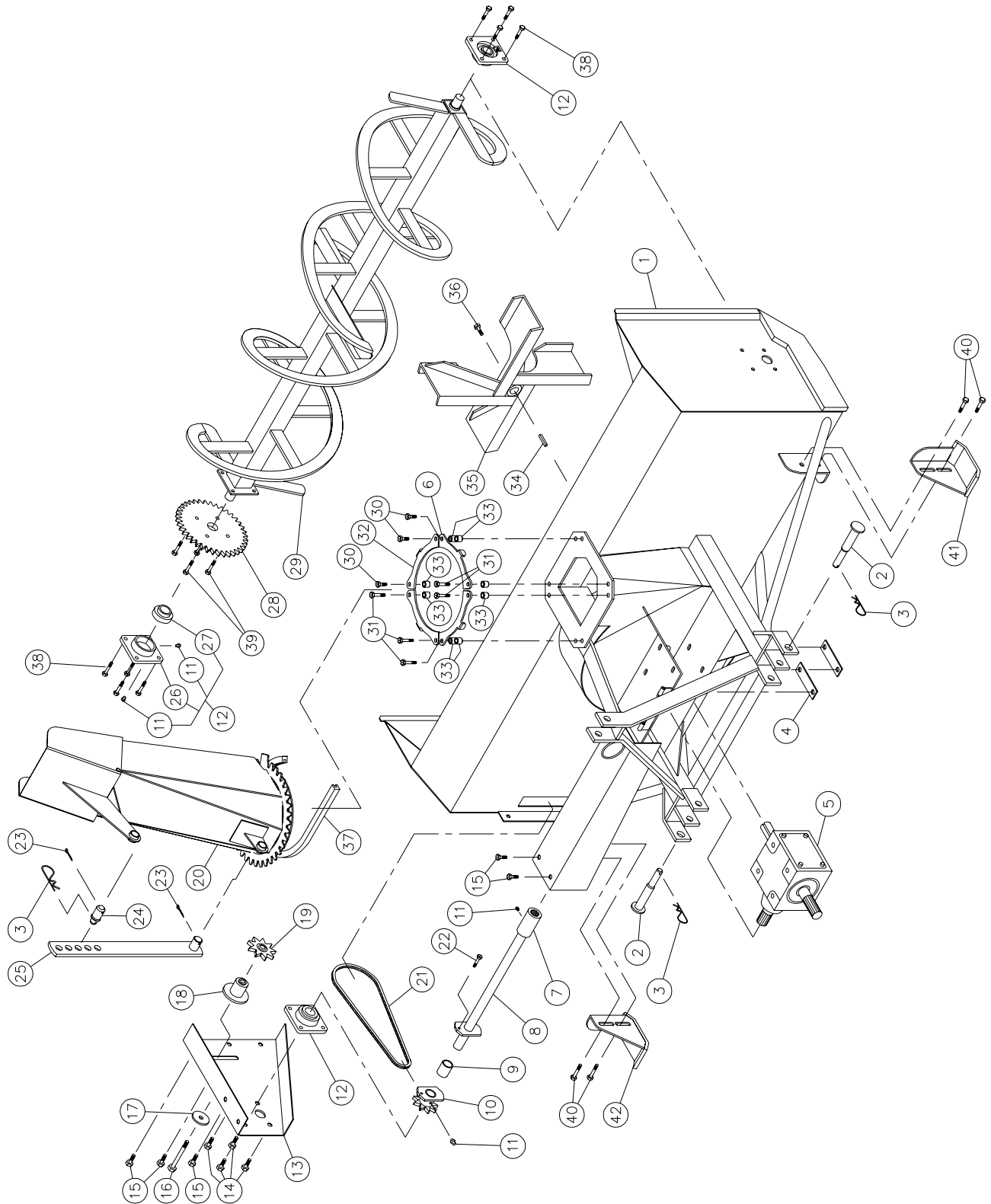

## SNOWBLOWER PUMA-74H (cont'd)

REF.	PART #	DESCRIPTION	QTY
1	120-00574	Frame 74" .....	1
2	110-03341	Pin category 1 & 2 .....	2
3	Std.	Hitch pin clip 5/32" .....	3
4	140-11101	Back plate .....	2
5	6451	Gear box T281 .....	1
6	130-31281	Chute retaining bracket .....	1
7	6466	Splined adaptor 1 1/4"-19 .....	1
8	110-03113	Auger drive shaft 29 5/16" lg overall (including #7) .....	1
9	6568	Bushing 1 1/4" i.d. x 1 7/16" o.d. x 2 1/2" lg .....	1
10	6569	Sprocket # 60 + shearplate (including #9 and #11) .....	1
11	Std.	Grease fitting 1/4"-28 straight .....	8
12	UCFD207-20	Bearing 1 1/4" ø + flange & 2 grease fittings (straight) .....	3
13	130-03612	Chain guard .....	1
14	300-40310	Bolt 1/2" NC x 1 1/2" lg + nylon locknut .....	4
15	300-38250	Bolt 7/16" NC x 1" lg + nylon locknut .....	5
16	300-40430	Bolt 1/2" NC x 3 1/2" lg + nylon locknut .....	1
17	378-40340	Flat washer 1/2" d.i. x 2" d.e. ....	1
18	110-07781	Idler .....	1
19	8186	Idler sprocket #60 .....	1
20	110-03041	Chute .....	1
21	190-00552	Chain #60 x 60 3/4" lg .....	1
21	26A60	Connecting link #60 .....	1
21	59-60	Offset link #60 .....	1
22	Std.	Shear bolt 5/16" NC x 1 1/4" lg grade 2 + nylon locknut .....	1
23	Std.	Cotter pin 5/32" x 1 1/2" .....	2
24	150-00641	Pin for chute adjusting bar .....	1
25	110-02991	Chute adjusting bar .....	1
26	FD207	Flange for 2 grease fittings .....	3
27	UC207-20	Bearing 1 1/4" ø .....	3
28	8021	Sprocket 60A38 T 1 1/4" ø .....	1
29	110-03061	Auger PUMA-74 .....	1
30	300-36340	Bolt 3/8" NC x 2" lg + nylon locknut & flat washer .....	3
31	300-36355	Bolt 3/8" NC x 2 1/4" lg + nylon locknut & flat washer .....	5
32	130-31291	Chute retaining bracket .....	3
33	160-07371	Spacer 11/16" o.d. x 7/16" i.d. x 5/8" lg .....	8
34	6276	Key 1/4" x 1/4" x 1 3/4" lg .....	1
35	110-03032	Impeller 8" x 22" ø 4 blades T 1 1/4" ø .....	1
36	300-36250	Bolt 3/8" NC x 1" lg (ass. with lock-tite 242) + lock washer .....	1
37	190-04091	U-shaped UHMW x 38 7/8" .....	1
38	300-38310	Bolt 7/16" NC x 1 1/2" lg + nylon locknut .....	8
39	300-38310	Bolt 7/16" NC x 1 1/2" lg + two-way locknut .....	4
40	300-40310	Bolt 1/2" NC x 1 1/2" lg + nylon locknut + flat washer .....	4
41	110-15391	Skid shoe (right side) .....	1
42	110-15392	Skid shoe (left side) .....	1



# MANUAL CHUTE KIT MD-4872

170-03841

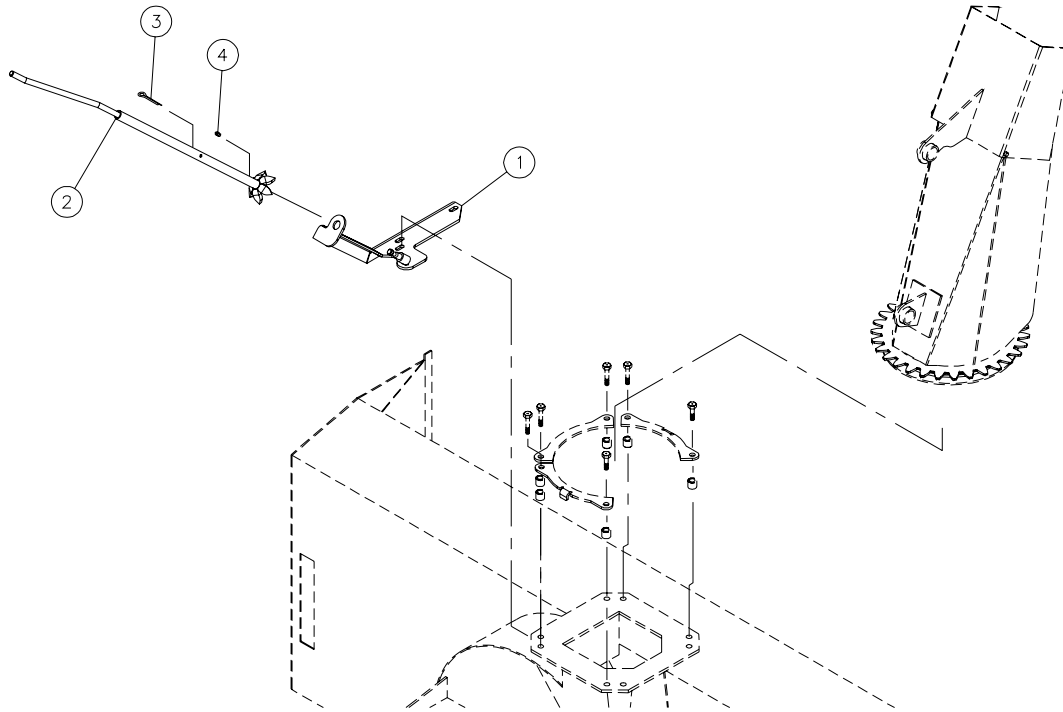

REF.	PART #	DESCRIPTION	QTY
1	110-27711	Base .....	1
2	110-27701	Crank .....	1
3	Std.	Cotter pin 5/32" x 1 1/2" lg .....	1
4	Std.	Grease fitting 1/4"-28 straight .....	1

# MANUAL CHUTE KIT MD-74

170-03931

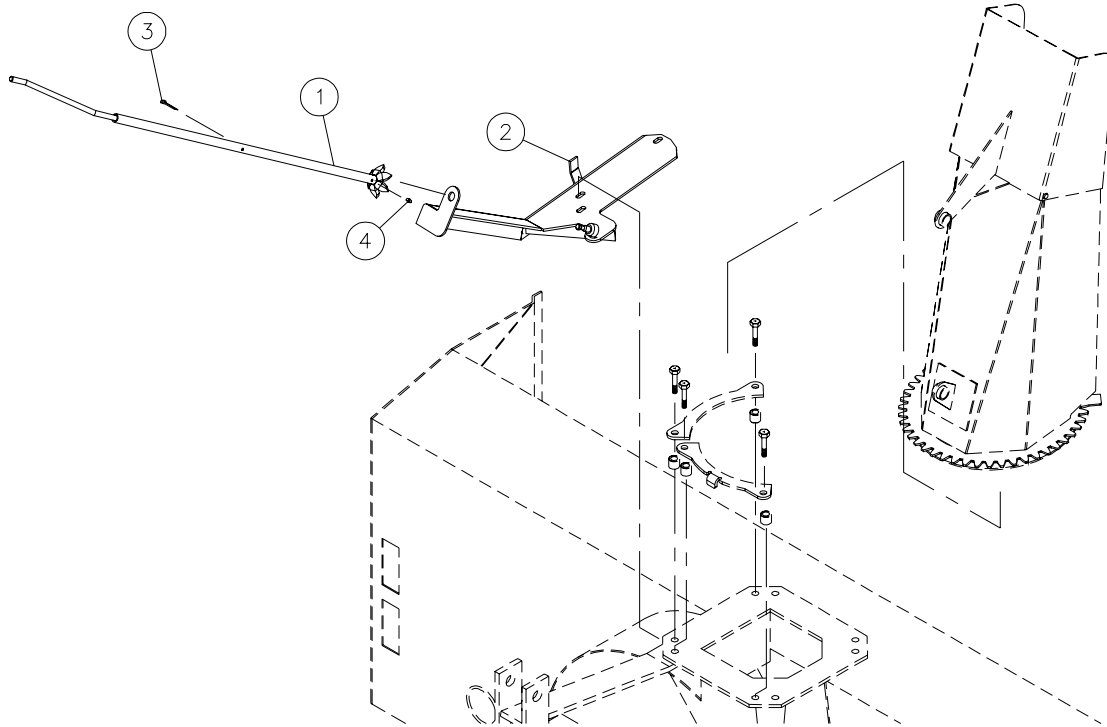

REF.	PART #	DESCRIPTION	QTY
1	110-28441	Crank .....	1
2	110-28382	Base .....	1
3	Std.	Cotter pin 5/32" x 1 1/2" lg .....	1
4	Std.	Grease fitting 1/4"-28 straight .....	1

# HYDRAULIC CHUTE KIT HRD-4872

170-03831

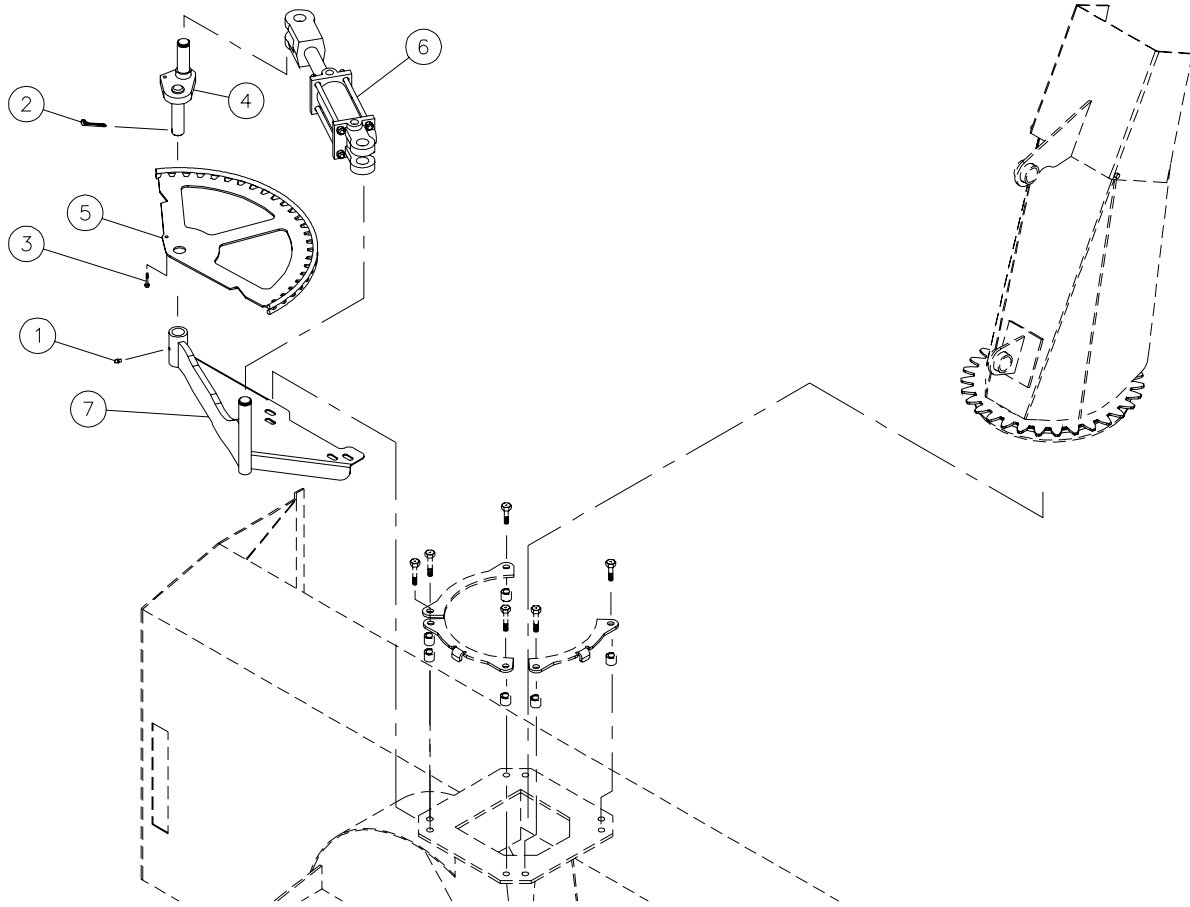

REF.	PART #	DESCRIPTION	QTY
1	Std.	Grease fitting 1/4"-28 straight .....	1
2	Std.	Cotter pin 1/4" x 2" .....	1
3	300-32280	Bolt 1/4" NC x 1 1/4" lg grade 5 + nylon locknut .....	1
4	110-27653	Pivot .....	1
5	110-27613	Arc .....	1
6	25TR04	Cylinder 2 1/2" - 4" stroke .....	opt.
7	110-27583	Frame .....	1

# HYDRAULIC CHUTE KIT HRD-74

170-03941

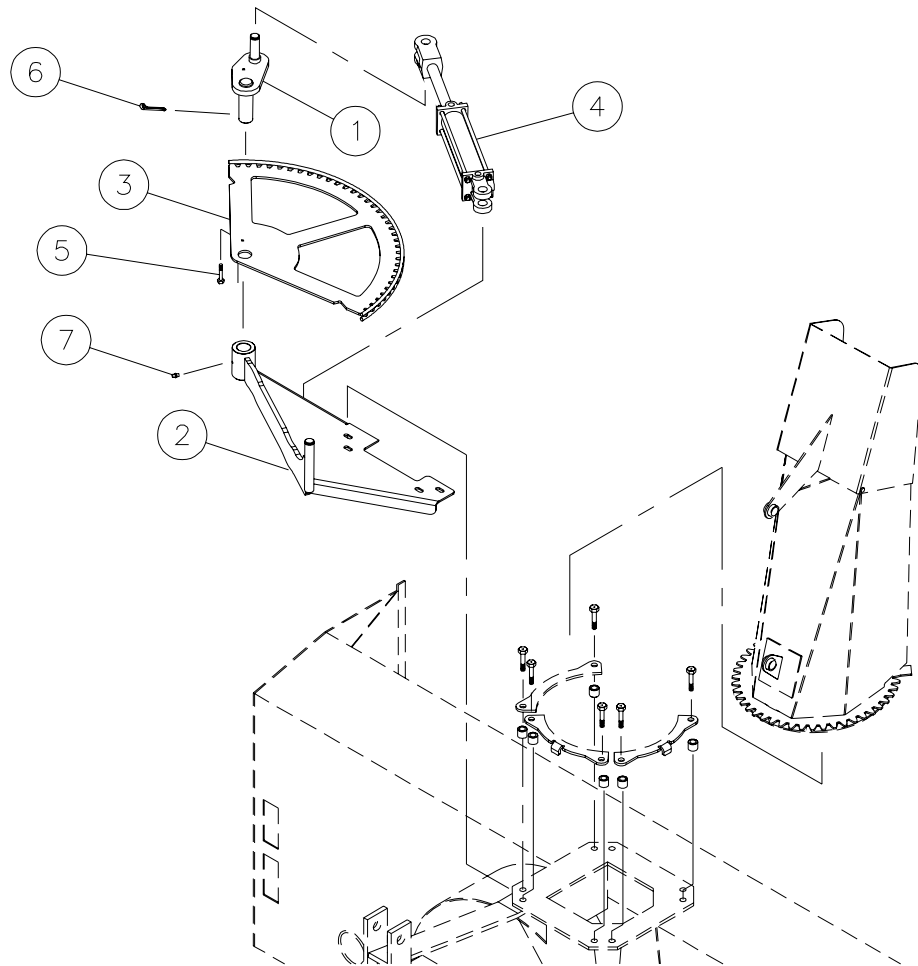

REF.	PART #	DESCRIPTION	QTY
1	110-28391	Pivot .....	1
2	110-28401	Base .....	1
3	110-28421	Arc .....	1
4	25TR08	Cylinder 2 1/2" - 8" stroke .....	opt.
5	300-32310	Bolt 1/4" NC x 1 1/2" lg grade 5 + nylon locknut .....	1
6	Std.	Cotter pin 1/4" x 2" .....	1
7	Std.	Grease fitting 1/4"-28 straight .....	1

# COMPONENTS

170-03313

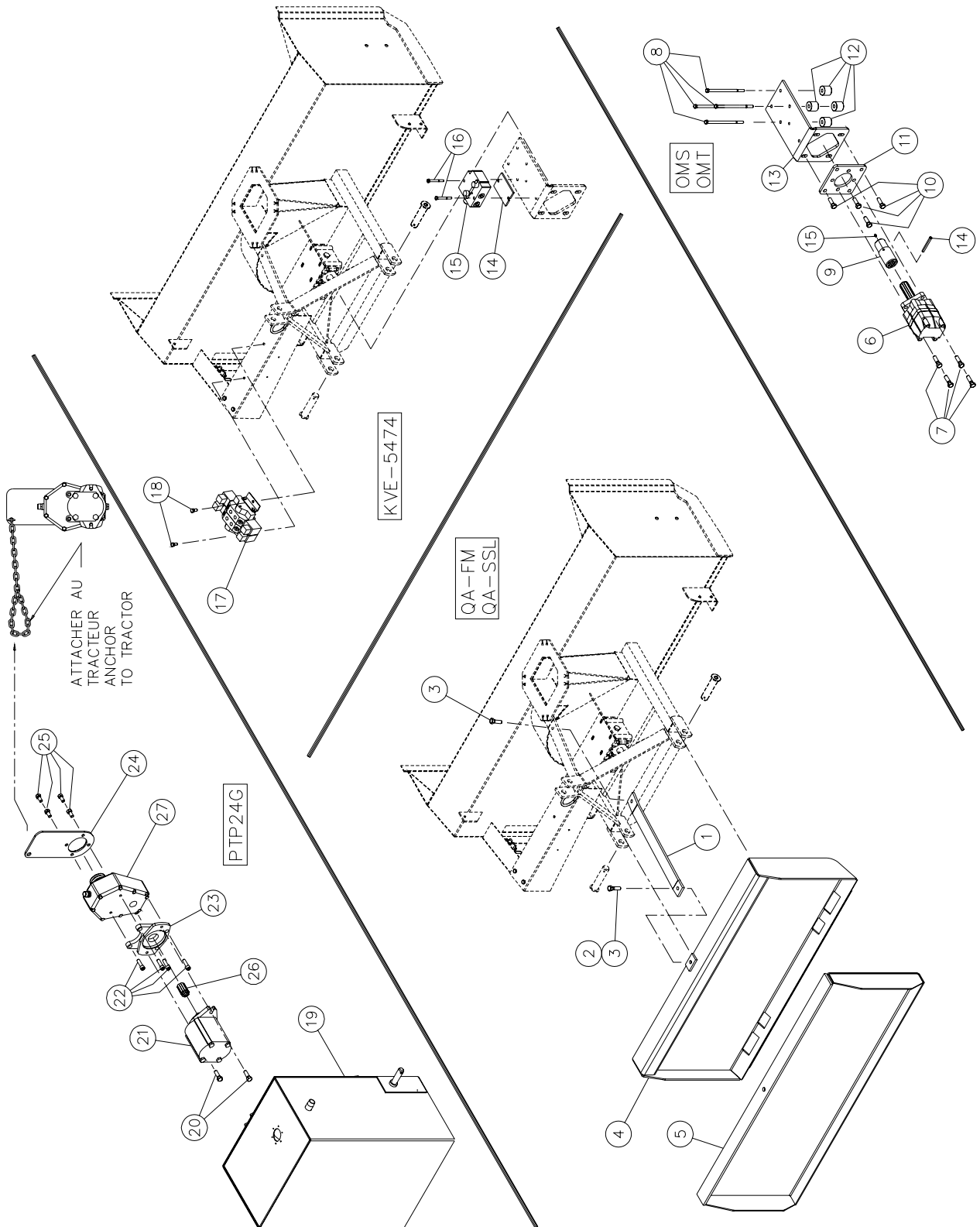

# COMPONENTS (cont'd)

## QUICK ATTACH

REF.	PART #	DESCRIPTION	QTY			
			QA64-SSL	QA64-FM	QA74-SSL	QA74-FM
1	140-13281	3-points hitch superior attachment for Puma 54-64-72 on skid steer loader .....	1	-	-	-
1	140-13571	3-points hitch superior attachment for Puma 54-64-72 front mount .....	-	1	-	-
1	140-10281	3-points hitch superior attachment for Puma 74 on skid steer loader .....	-	-	1	-
1	140-12671	3-points hitch superior attachment for Puma 74 front mount .....	-	-	-	1
2	300-40325	Bolt 1/2" NC x 1 3/4" lg + nylon locknut .....	1	1	-	-
3	300-40310	Bolt 1/2" NC x 1 1/2" lg + nylon locknut .....	1	1	-	-
3	300-44340	Bolt 5/8" NC x 2" lg + nylon locknut .....	-	-	2	2
4	120-04191	Quick attach for Puma 54-64-72 on skid steer loader .....	1	-	-	-
4	120-03001	Quick attach for Puma 74 on skid steer loader .....	-	-	1	-
5	110-21221	Quick attach for Puma 54-64-72 front mount (for welding) .....	-	1	-	-
5	110-19592	Quick attach for Puma 74 front mount (for welding) .....	-	-	-	1

## HYDRAULIC MOTORS

6	MLHS 100	Hydraulic motor (oil volume required 15 to 20 gallons; horse power available 15 to 19 HP) .....	1
6	MLHS 125	Hydraulic motor (oil volume required 20 to 25 gallons; horse power available 19 to 24 HP) .....	1
6	MLHS 160	Hydraulic motor (oil volume required 25 to 30 gallons; horse power available 22 to 25 HP) .....	1
6	MLHT 160	Hydraulic motor (oil volume required 28 to 35 gallons; horse power available 28 to 39 HP) .....	1

## MOUNTING KITS FOR HYDRAULIC MOTORS

REF.	PART #	DESCRIPTION	QTY		
			OMS-64	OMS-74	OMT-74
7	300-40340	Bolt 1/2" NC x 2" lg + nylon locknut .....	4	4	4
8	300-36640	Bolt 3/8" NC x 7" lg + nylon locknut + flat washer .....	4	4	-
8	300-36670	Bolt 3/8" NC x 7 1/2" lg + nylon locknut + flat washer .....	-	-	4
9	110-19541	Adaptor 1 3/8"-6 x 1" round x 4 3/4" lg .....	1	-	-
9	190-05311	Adaptor 1 3/8"-6 x 4 3/4" lg .....	-	1	1
10	300-40325	Bolt 1/2" NC x 1 3/4" lg + nylon locknut + flat washer .....	4	4	4
11	130-26911	Mounting plate for MLHS motor .....	1	1	-
11	130-30601	Mounting plate for MLHT motor .....	-	-	1
12	160-07571	Spacer MLHS motor support 1/2" x 1 1/2" x 1 3/8" lg .....	4	-	-
12	160-17141	Spacer MLHS motor support 1/2" x 1 1/2" x 1 3/16" lg .....	-	4	-
12	160-10592	Spacer MLHT motor support for Puma-74 1/2" x 1 1/2" x 1 15/16" lg .....	-	-	4
13	130-20383	MLHS motor support for Puma 54-64-72 .....	1	-	-
13	130-22354	MLHS motor support for Puma 74 .....	-	1	-
13	130-30632	MLHT motor support for Puma 74 .....	-	-	1
14	Std.	Roll pin .....	-	1	1
15	Std.	Grease fitting 1/4"-28 straight .....	1	1	1

---

---

## ***COMPONENTS (cont'd)***

---

### ***ELECTRIC VALVE KIT KVE-5474***

<b>REF.</b>	<b>PART #</b>	<b>DESCRIPTION</b>	<b>QTY</b>
14	130-30571	Spacer flow divider .....	1
15	10001	Flow divider valve .....	1
16	300-34400	Bolt 5/16" NC x 3" lg + nylon locknut .....	2
17	10000	Double solenoid valve .....	1
18	300-36250	Bolt 3/8" NC x 1" lg + nylon locknut .....	2

### ***HYDRAULIC PUMP ON P.T.O. PTP24G***

<b>REF.</b>	<b>PART #</b>	<b>DESCRIPTION</b>	<b>QTY</b>
19	110-19511	Oil reservoir .....	1
20	308-36040	Bolt M12 x 1.75 x 20 mm lg + lock washer & flat washer .....	2
21	10004	Pump 24GPM at 540 RPM .....	1
22	331-13520	Hexagonal socket set screw M10 x 1.5 x 20 mm lg .....	4
23	10003	Mounting flange .....	1
24	130-30581	Gear box mounting plate .....	1
25	308-36025	Bolt M12 x 1.75 x 15 mm lg .....	4
26	10009	Splined adaptor «pump 24G - Gear box 3:5» .....	1
27	10002	Gear box 3:5 .....	1

# HYDRAULIC CIRCUIT *Motor without option KVE-5474*

170-03031

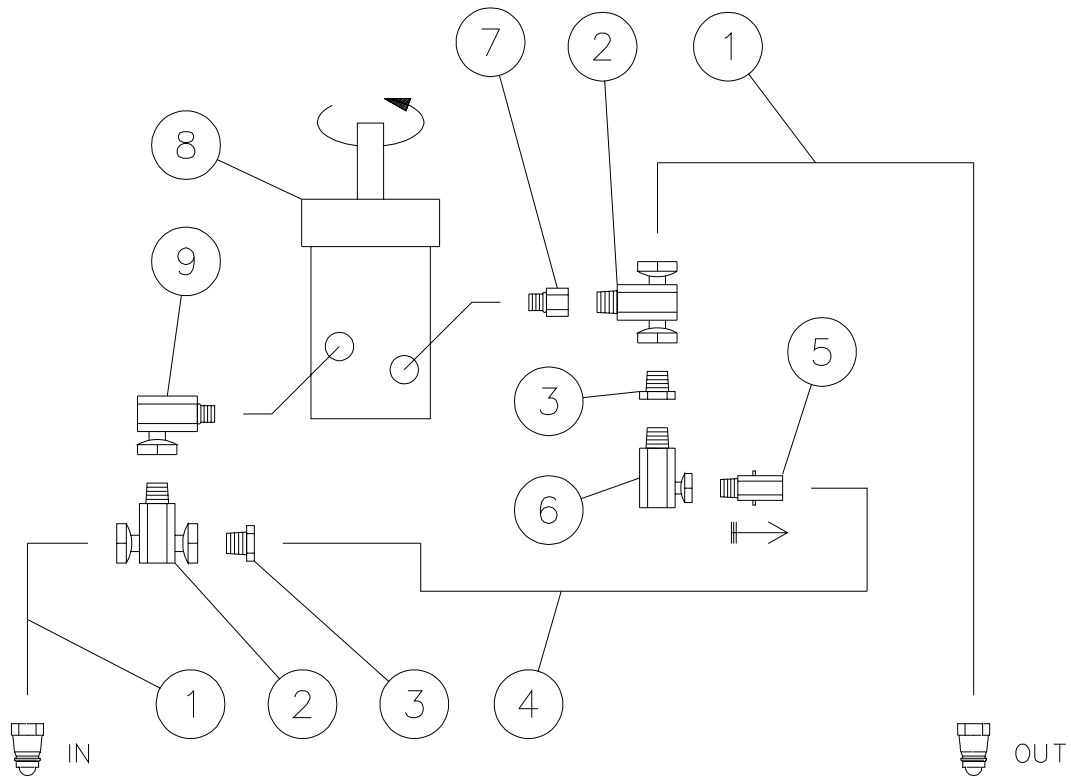

REF.	PART #	DESCRIPTION	QTY			
			MLHS-100	MLHS-125	MLHS-160	MLHT-160
1	190-05231	Hose 3/4" R2 x 60" lg + 2 fittings 12U112 .....	2	2	2	2
2	9457-12-12	«T» fitting .....	2	2	2	2
3	3109-12-08	Fitting (reducer) .....	2	2	2	2
4	190-05241	Hose 3/8" R1 x 20" lg + 2 fittings 6U108 .....	1	1	1	1
5	LT-50-0	Check valve .....	1	1	1	1
6	9405-08-08	Fitting 90 deg. ....	1	1	1	1
7	3269-10-12	Straight fitting .....	1	1	1	1
8	MLHS-100	Hydraulic motor MLHS-100 .....	1	-	-	-
8	MLHS-125	Hydraulic motor MLHS-125 .....	-	1	-	-
8	MLHS-160	Hydraulic motor MLHS-160 .....	-	-	1	-
8	MLHT-160	Hydraulic motor MLHT-160 .....	-	-	-	1
9	9515-10-12	Fitting 90 deg. ....	1	1	1	1



# HYDRAULIC CIRCUIT *Motor with option KVE-5474*

170-03011

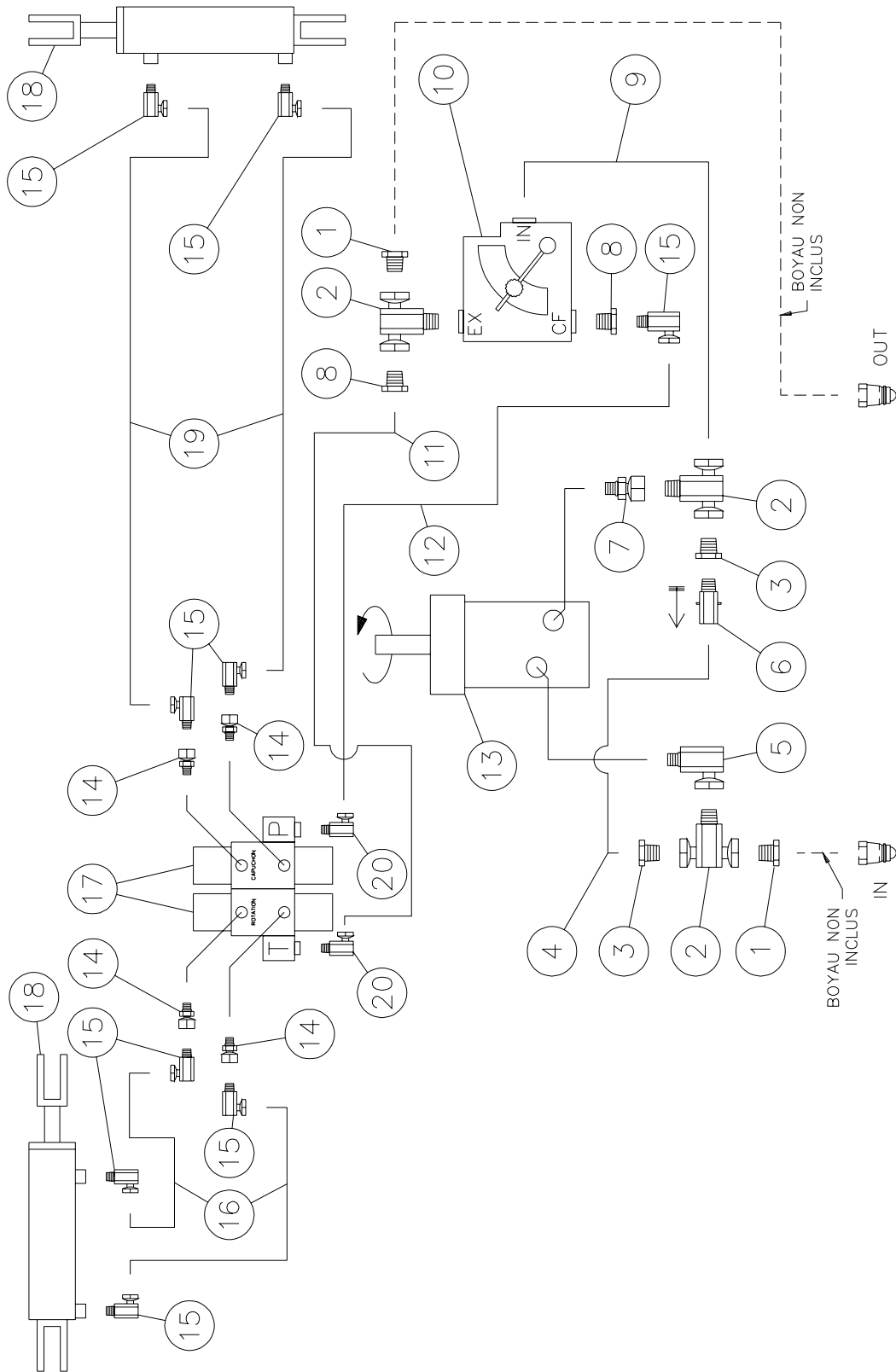

**Pressure at the CF output is adjusted at 400 lbs/po<sup>2</sup>**

# HYDRAULIC CIRCUIT *Motor with option KVE-5474 (cont'd)*

REF.	PART #	DESCRIPTION	QTY			
			MLHS- 100KVE	MLHS- 125KVE	MLHS- 160KVE	MLHT- 160KVE
1	190-05231	Hose 3/4" R2 x 60" lg + 2 fittings 12U112 .....	2	2	2	2
2	9457-12-12	«T» fitting .....	3	3	3	3
3	3109-12-08	Fitting (reducer) .....	2	2	2	2
4	190-05241	Hose 3/8" R1 x 20" lg + 2 fittings 6U108 .....	1	1	1	1
5	9515-10-12	Fitting 90 deg. ....	1	1	1	1
6	LT-50-0	Check valve .....	1	1	1	1
7	9315-10-12	Straight fitting .....	1	1	1	1
8	3109-12-06	Fitting (reducer) .....	2	2	2	2
9	190-03071	Hose 3/4" R2 x 30" LG + 2 fittings 12U112 .....	1	1	1	1
10	10001	Flow divider .....	1	1	1	1
11	190-05251	Hose 3/8" R1 x 28" LG + 2 fittings 6U106 .....	1	1	1	1
12	190-05261	Hose 3/8" R1 x 24" LG + 2 fittings 6U106 .....	1	1	1	1
13	MLHS-100	Hydraulic motor MLHS-100 .....	1	-	-	-
13	MLHS-125	Hydraulic motor MLHS-125 .....	-	1	-	-
13	MLHS-160	Hydraulic motor MLHS-160 .....	-	-	1	-
13	MLHT-160	Hydraulic motor MLHT-160 .....	-	-	-	1
14	9315-06-06	Straight fitting .....	4	4	4	4
15	9405-06-06	Fitting 90 deg. ....	9	9	9	9
16	190-05271	Hose 3/8" R1 x 29" LG + 2 fittings 6U106 .....	2	2	2	2
17	10000	Double solenoid valve .....	1	1	1	1
18	25 TR 04	Cylinder 2 1/2" x 4" stroke for PUMA-54 or 64 .....	2	2	2	2
18	25 TR 08	Cylinder 2 1/2" x 8" stroke for PUMA-74 .....	2	2	2	2
19	190-05281	Hose 3/8" R1 x 50" lg + 2 fittings 6U106 .....	2	2	2	2
20	9515-08-06	Fitting 90 deg. ....	2	2	2	2

# ELECTRIC CIRCUIT FOR OPTION KVE-5474

170-03023

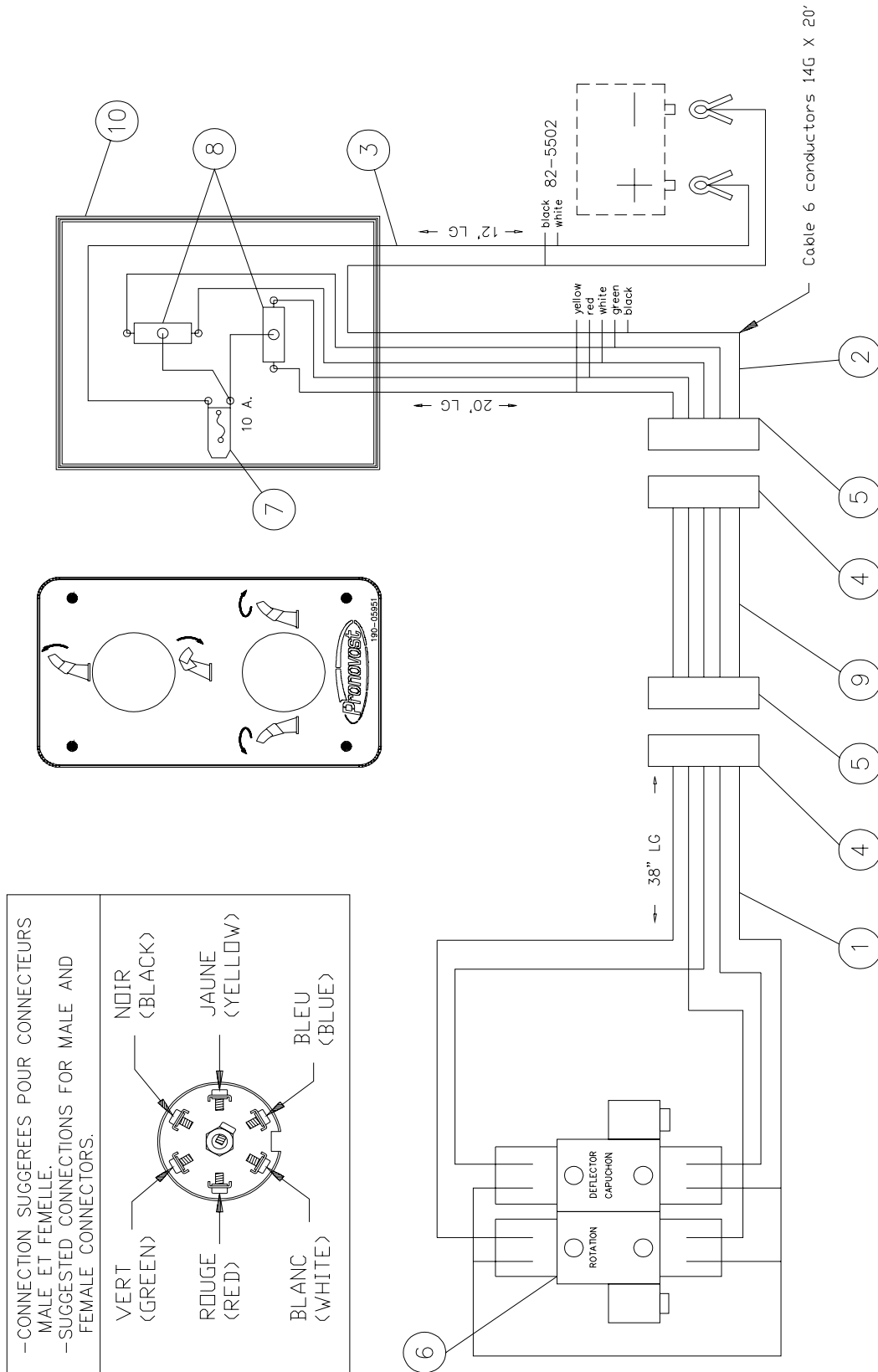

-CONNECTION SUGGEREES POUR CONNECTEURS MALE ET FEMELLE.  
-SUGGESTED CONNECTIONS FOR MALE AND FEMALE CONNECTORS.

---

---

## ***ELECTRIC CIRCUIT FOR OPTION KVE-5474 (cont'd)***

---

<b>REF.</b>	<b>PART #</b>	<b>DESCRIPTION</b>	<b>QTY</b>
1	190-05771	Cable 38" snowblower side .....	1
2	190-05781	Cable 20' tractor side .....	1
3	190-05791	Cable 12' tractor side .....	1
4	52065	Male connector .....	2
5	52078	Female connector .....	2
6	10000	Double solenoid valve .....	1
7	18005	Fuse support and fuse 10 amp. ....	1
8	10007	Switch (on) - off - (on) normally off 3 positions .....	2
9		Extension (if required) .....	1
10	10008	Control box (empty) .....	1

# HYDRAULIC CIRCUIT *For hydraulic pump on P.T.O. PTP24G*

170-03043

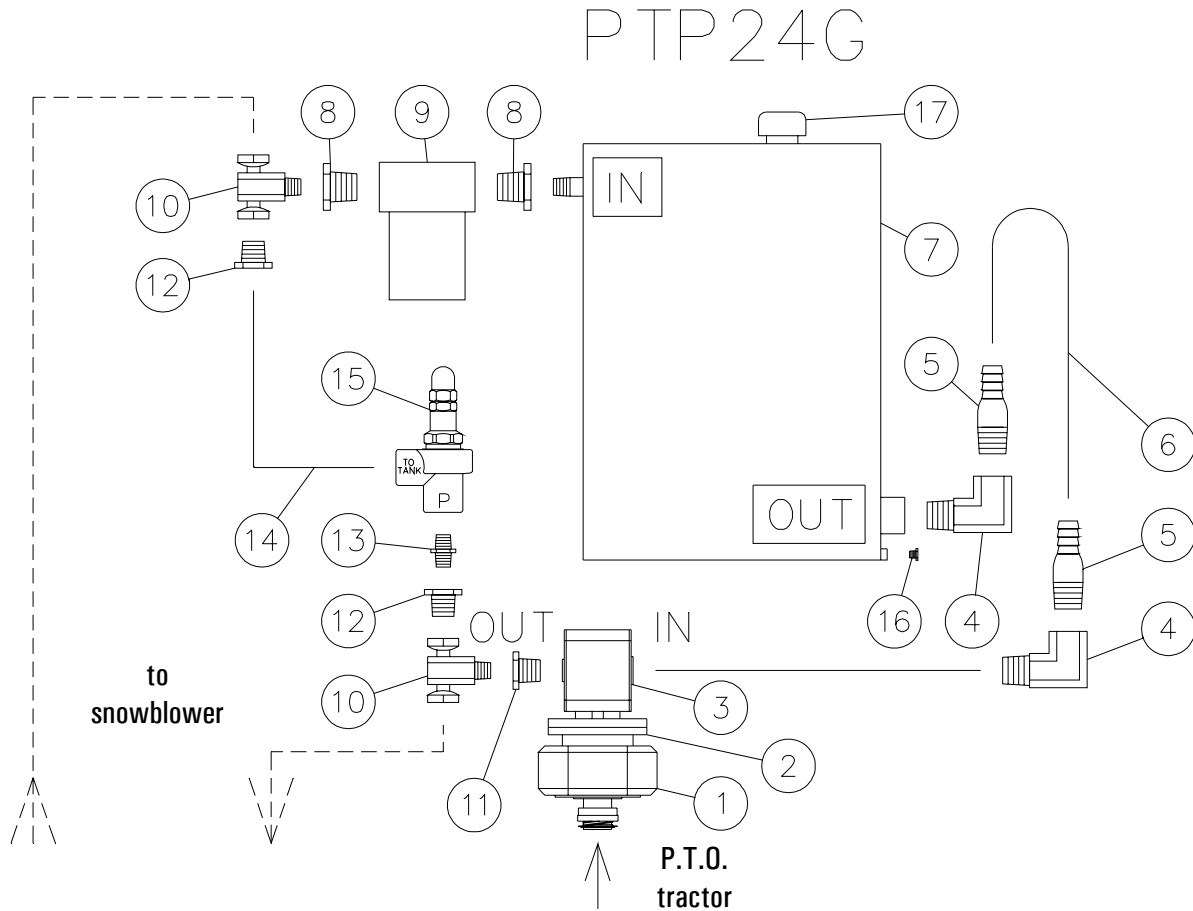

REF.	PART #	DESCRIPTION	QTY
1	10002	Pump gear box 3:5 (33 HP capacity) .....	1
2	10003	Flange .....	1
3	10004	Pump 24 gpm at 540 rpm .....	1
4	3409-20-20	Fitting 90 deg. ....	2
5	10005	Straight fitting .....	2
6	190-05291	Hose 1 1/4" low pressure 6' .....	1
7	110-19511	Oil reservoir (capacity 32 gallons) .....	1
8	3109-20-12	Reducer .....	2
9	10006	Oil filter unit c/w element (capacity 45 gpm) .....	1
10	5855-12	«T» fitting .....	2
11	3269-16-12	Reducer .....	1
12	3109-12-08	Reducer .....	2
13	3069-08	Straight fitting .....	1
14	190-05841	Hose 1/2" x 60" lg + 2 fittings 8U 108 .....	1
15	JT-50	Relief valve 1/2" NPT (adjusted at 2500 lbs) .....	1
16	3159-08	Drain plug .....	1
17	10010	Filling plug .....	1

# GEAR BOX # 6550

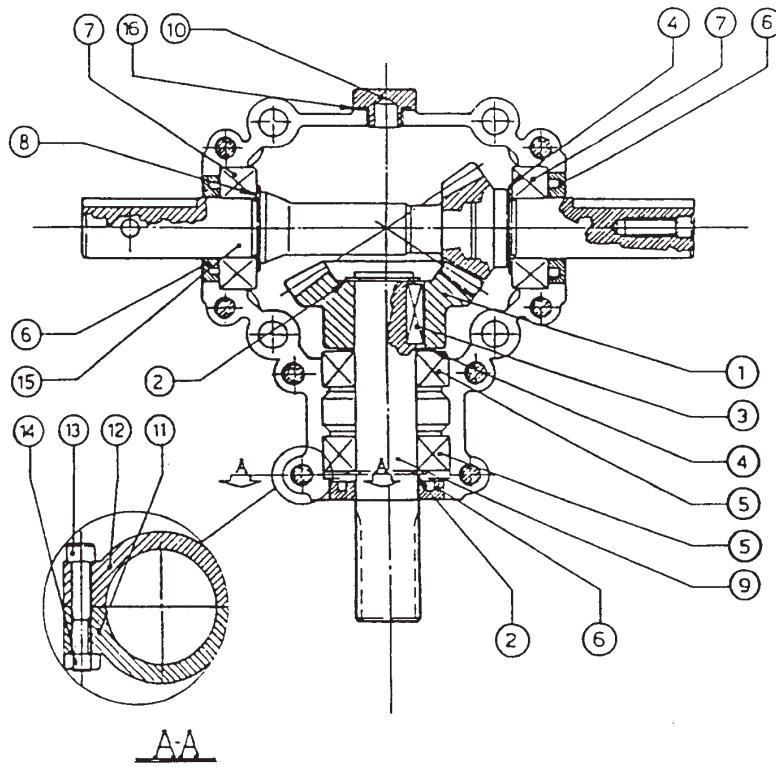

REF.	PART #	DESCRIPTION	QTY
1	6547	Gear Z24 .....	1
2	6548	Outside circlip .....	2
3	6549	Parallel key 8 x 7 x 25 .....	1
4	6562	Shim .....	2
5	6551	Bearing 6205 .....	2
6	6552	Oil seal .....	3
7	6553	Bearing .....	2
8	6554	Shim .....	1
9	6555	Side shaft (1") .....	1
10	6556	Plug 3/8" GAS .....	1
11	6557	Casing A .....	1
12	6558	Casing A .....	1
13	6559	Bolt M8 x 45 8,8 .....	8
14	6428	Hex. nut M8 8 .....	8
15	6560	Pinion shaft Z16 for impeller (1" & 1") .....	1
16	6425	O-ring OR-3062 .....	1

# GEAR BOX # 6451 (T281)

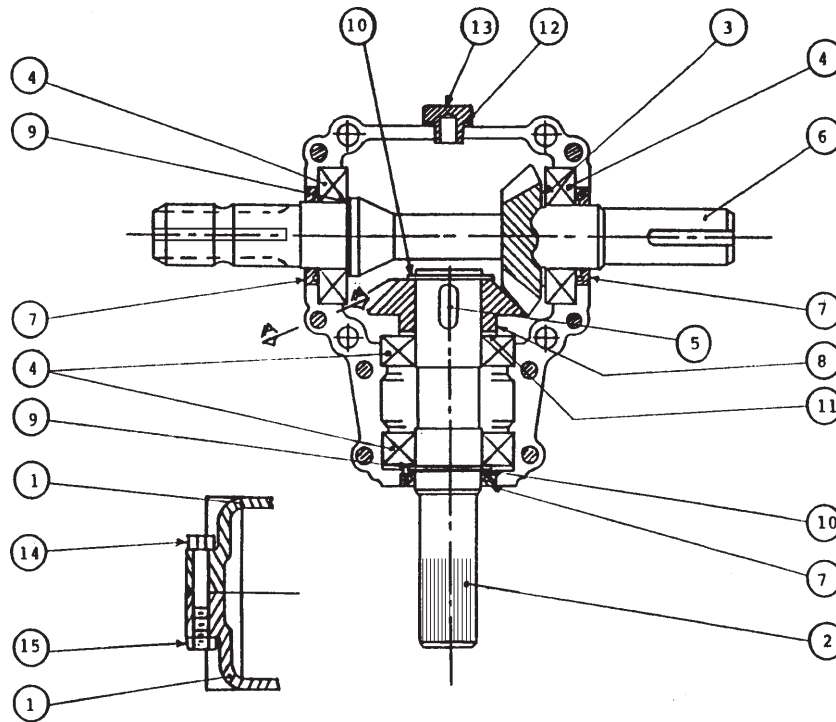

REF.	PART #	DESCRIPTION	QTY
1	6414	Casing .....	2
2	6429	Side shaft (1 ¼" - 19 splines) .....	1
3	6416	Spacer 35,3 x 48 .....	1
4	6207-2RS	Ball bearing .....	4
5	6418	Key 10 x 8 x 30 .....	1
6	6419	Impeller shaft (1 ¼" & 1 3/8" - 6 splines) .....	1
7	6420	Seal 35 x 52 x 7 .....	3
8	6421	Gear Z19 .....	1
9	6422	Spacer 35.3 x 0.5 .....	2
10	6423	Snap ring 35 UNI7435 .....	2
11	6424	Spacer 35.3 x 0.6 .....	1
12	6425	Oil seal .....	1
13	6426	Oil plug (oil level) .....	1
14	6427	Bolt M8 x 55 .....	8
15	6428	Nut M8 .....	8

# GEAR BOX # 8251 (T27D)

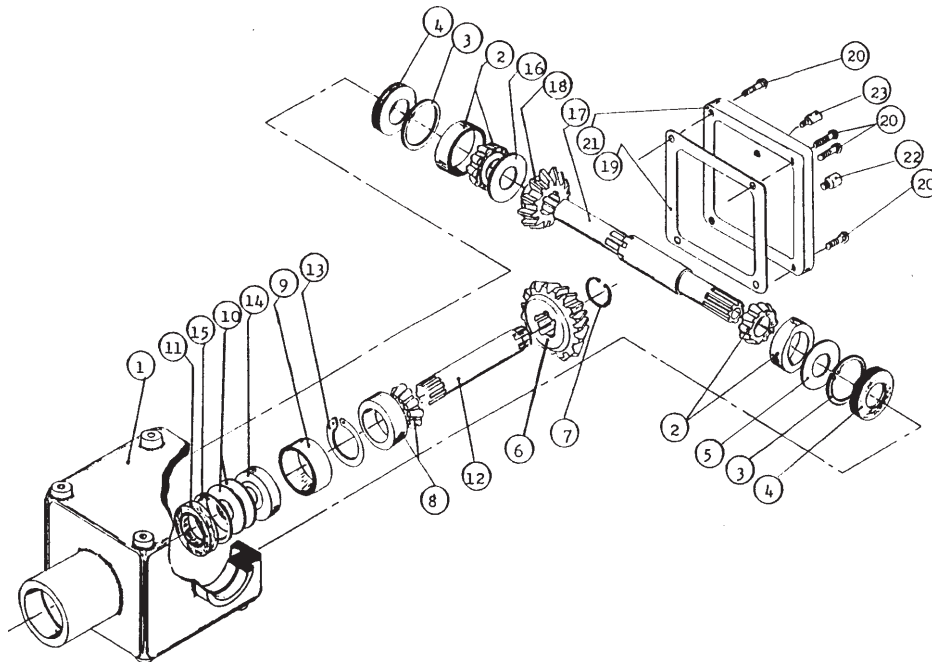

REF.	PART #	DESCRIPTION	QTY
1	8043	Casing .....	1
2	8044	Roller bearing no. 30208 .....	2
3	8045	Inside circlip 80mm .....	2
4	8046	Oil seal 40 x 80 x 12mm .....	2
5	8047	Adjusting washer .....	1
6	8048	Gear Z18 .....	1
7	8049	Outside circlip 40mm .....	1
8	8050	Roller bearing no. 30207 .....	1
9	8051	Spacer ring .....	1
10	8052	Adjusting washer .....	2
11	8053	Oil seal 35 x 72 x 12mm .....	1
12	8054	Side shaft (1 1/4" - 19 splines) .....	1
13	8055	Outside circlip 35mm .....	1
14	8056	Ball bearing no. 6207 .....	1
15	8057	Inside circlip 72mm .....	1
16	8058	Adjusting washer .....	1
17	8252	Impeller shaft (40 mm & 1 3/8" - 6 splines) .....	1
18	8060	Gear Z-18 .....	1
19	8061	Gasket .....	1
20	8062	Bolt M10 x 14mm .....	4
21	8063	Cover .....	1
22	8064	Oil plug .....	1
23	8065	Oil filler plug .....	1



# CYLINDER 25TR04

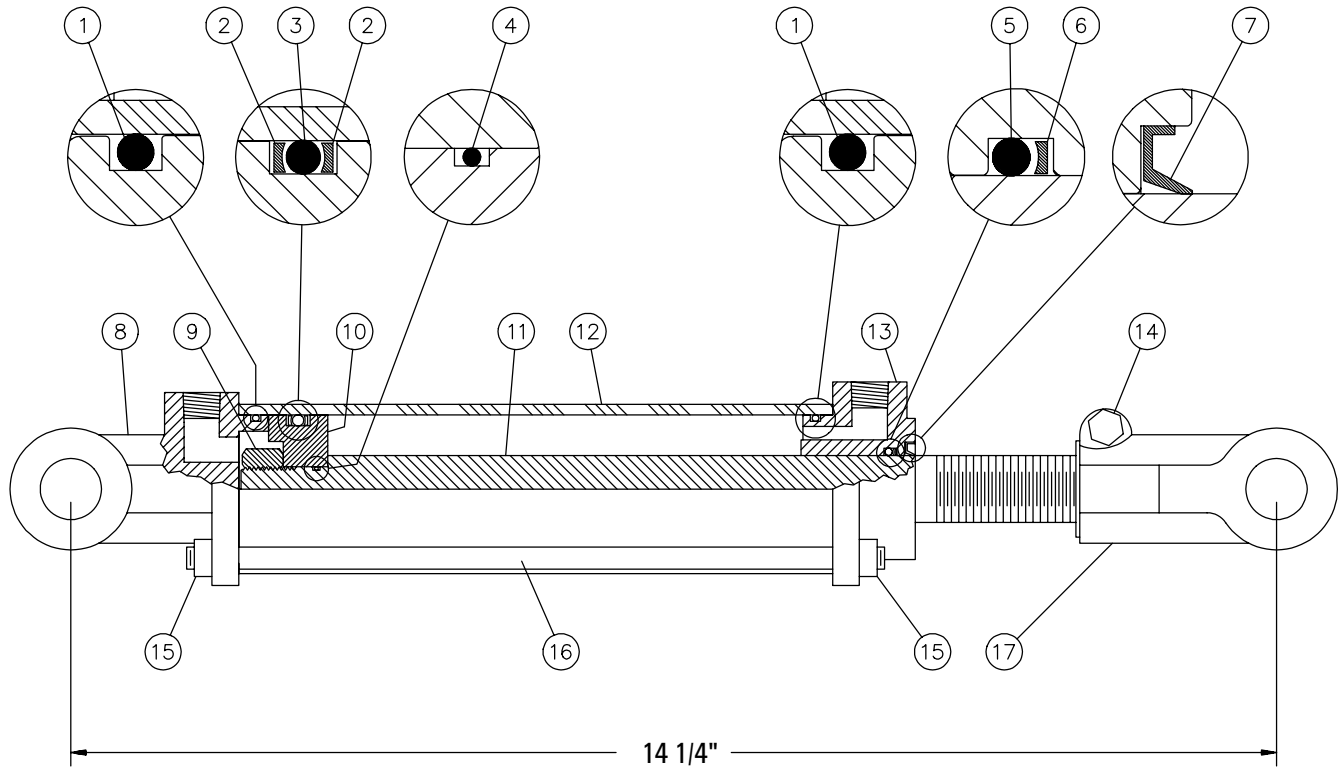

REF.	PART #	DESCRIPTION	QTY
1	See #RK25TR	O-ring 1/8" x 2 1/4" x 2 1/2" .....	2
2	See #RK25TR	Back-up 2 1/2" o.d. x 3/16 ø .....	2
3	See #RK25TR	O-ring 3/16" x 2 1/8" x 2 1/2" .....	1
4	See #RK25TR	O-ring 1/16" x 5/8" x 3/4" .....	1
5	See #RK25TR	O-ring 1/8" x 1 1/8" x 1 3/8" .....	1
6	See #RK25TR	Back-up 1 3/8" o.d. x 1/8" ø .....	1
7	See #RK25TR	Wiper 1 1/8" i.d. x 1 5/8" o.d. ....	1
8	492401	Yoke (for 2 1/2" tube) .....	1
9	338-46000	Nut 3/4" NF .....	1
10	4924-31	Piston 2 1/2" ø .....	1
11	491980-04	Piston rod 1 1/8" .....	1
12	491668-04	Cylinder body 2 1/2" ø .....	1
13	492421	Head (for 2 1/2" tube) .....	1
14	300-36355	Bolt 3/8" NC x 2 1/4" + nut .....	1
15	336-36000	Nut 3/8" NC .....	8
16	Std.	Threaded rod 3/8" NC x 8" lg .....	4
17	458599	Yoke (for 1 1/8" rod) .....	1
NI*	8183	Pin 1" ø + cotter pin .....	2
NI*	RK25TR	Repair kit for 2 1/2" cylinder (includes # 1, 2, 3, 4, 5, 6, & 7) .....	1

\*NI = NOT ILLUSTRATED

# CYLINDER 25TR08

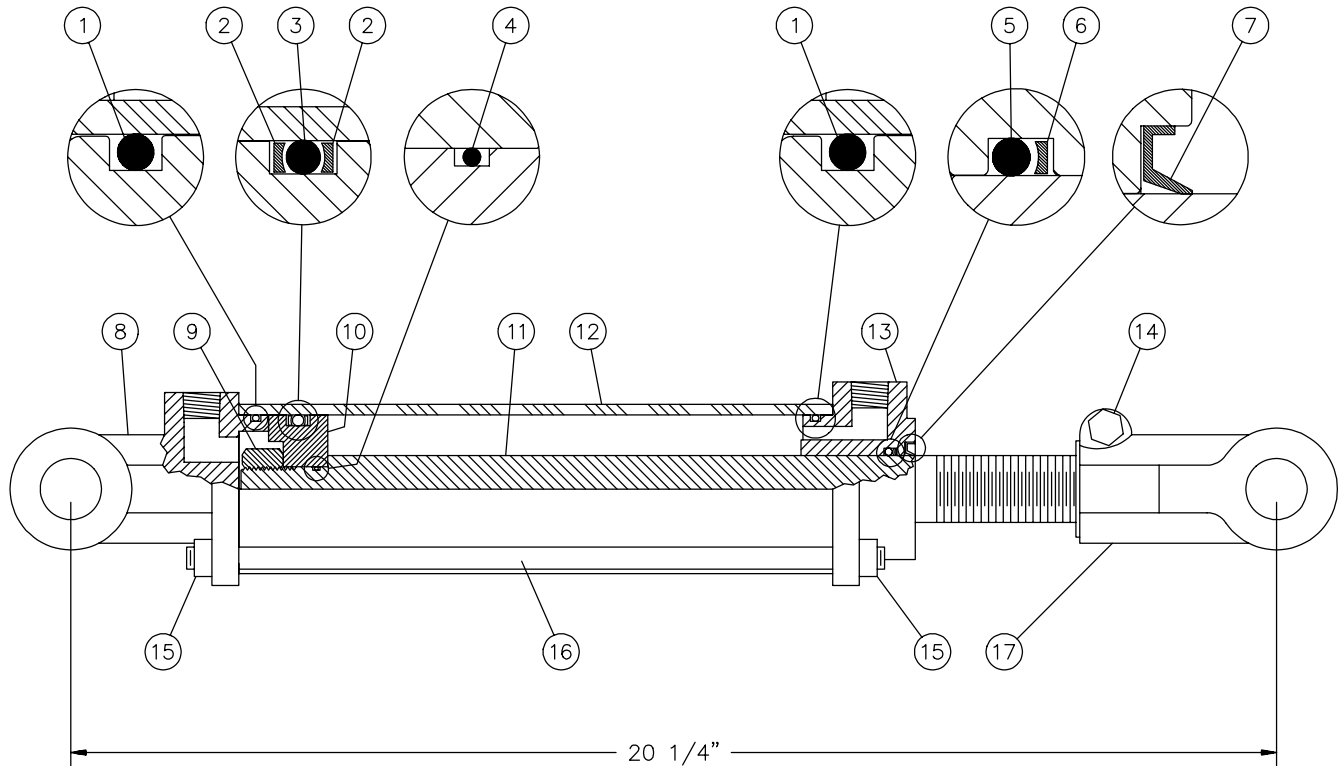

REF.	PART #	DESCRIPTION	QTY
1	See #RK25TR	O-ring 1/8" x 2 1/4" x 2 1/2" .....	2
2	See #RK25TR	Back-up 2 1/2" o.d. x 3/16 ø .....	2
3	See #RK25TR	O-ring 3/16" x 2 1/8" x 2 1/2" .....	1
4	See #RK25TR	O-ring 1/16" x 5/8" x 3/4" .....	1
5	See #RK25TR	O-ring 1/8" x 1 1/8" x 1 3/8" .....	1
6	See #RK25TR	Back-up 1 3/8" o.d. x 1/8" ø .....	1
7	See #RK25TR	Wiper 1 1/8" i.d. x 1 5/8" o.d. ....	1
8	492401	Yoke (for 2 1/2" tube) .....	1
9	338-46000	Nut 3/4" NF .....	1
10	4924-31	Piston 2 1/2" ø .....	1
11	491980	Piston rod 1 1/8" .....	1
12	491668	Cylinder body 2 1/2" ø .....	1
13	492421	Head (for 2 1/2" tube) .....	1
14	300-36355	Bolt 3/8" NC x 2 1/4" + nut .....	1
15	336-36000	Nut 3/8" NC .....	8
16	Std.	Threaded rod 3/8" NC x 12" lg .....	4
17	458599	Yoke (for 1 1/8" rod) .....	1
NI*	8183	Pin 1" ø + cotter pin .....	2
NI*	RK25TR	Repair kit for 2 1/2" cylinder (includes # 1, 2, 3, 4, 5, 6, & 7) .....	1

\*NI = NOT ILLUSTRATED

# HYDRAULIC MOTOR MLHS

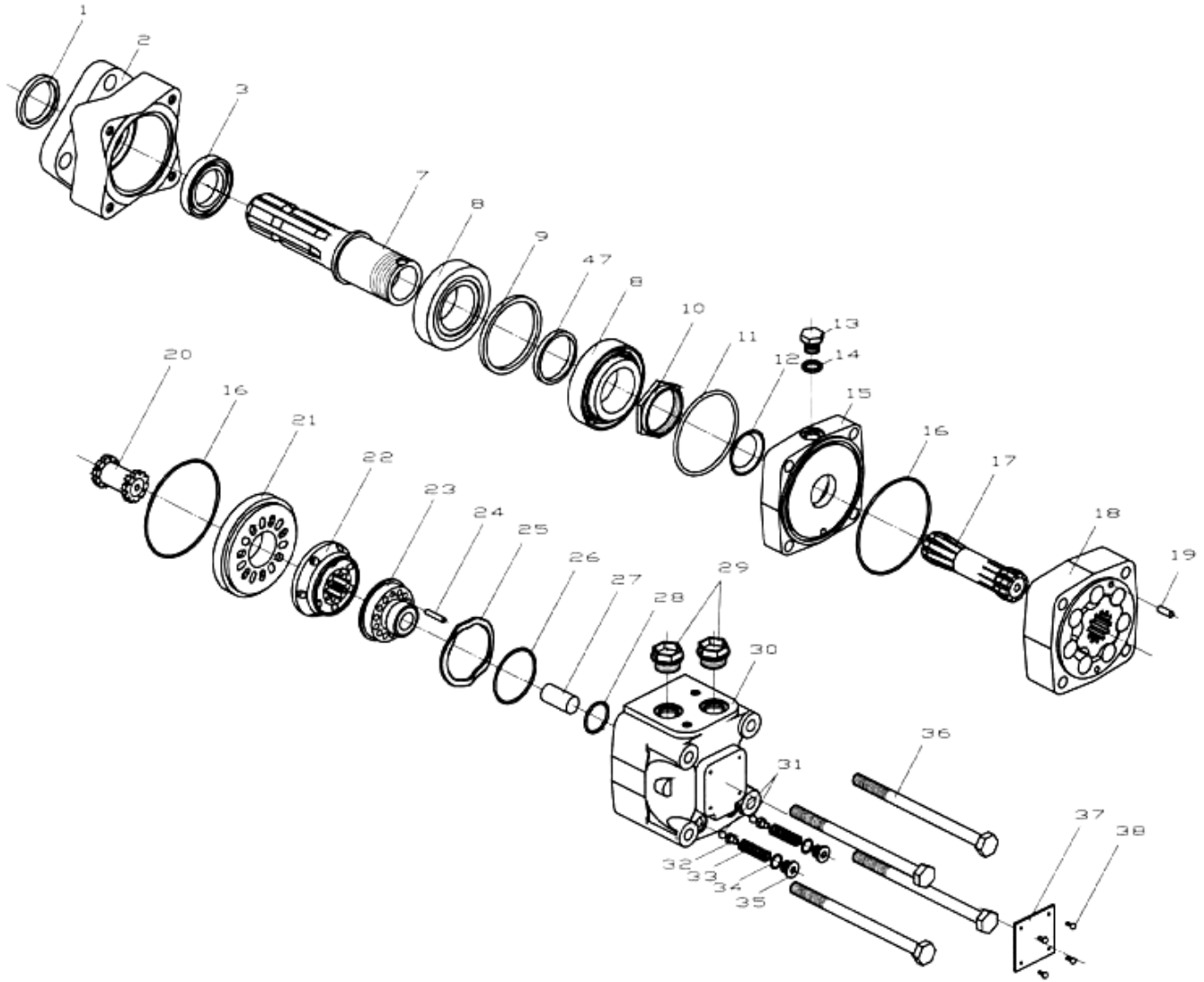

REF.	PART #	DESCRIPTION	QTY
kit	8371	Repair kit .....	1



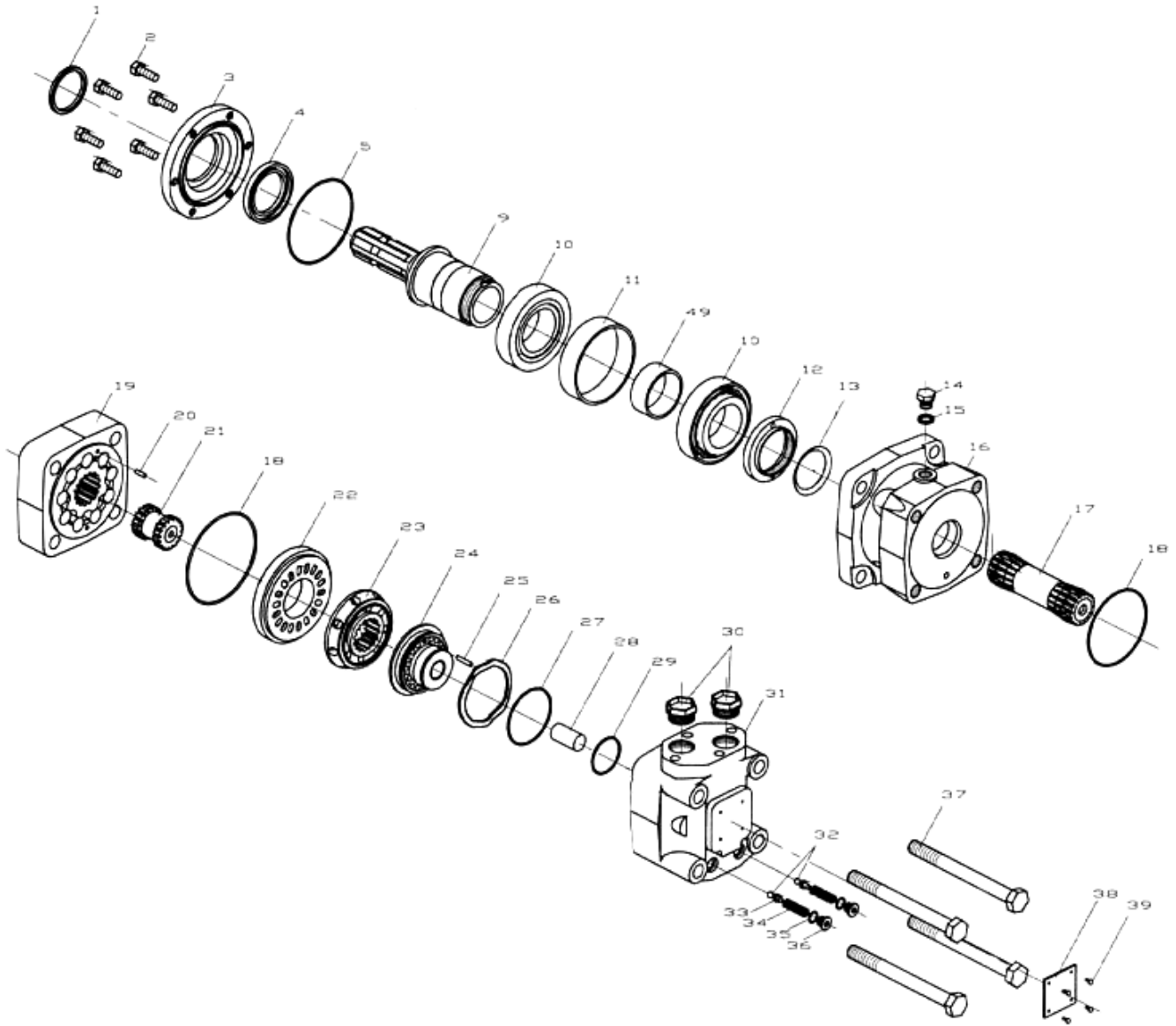



# HYDRAULIC MOTOR MLHT







REF.	PART #	DESCRIPTION	QTY
	8372	Repair kit .....	1

# TORQUE CHART

## TORQUE SPECIFICATION TABLE

Thread UNC and UNF		Grade 2 				Grade 5   				Grade 8*   			
Bolt size		Torque				Torque				Torque			
Inches	mm	Pound feet min.	max.	Newton meters min.	max.	Pound feet min.	max.	Newton meters min.	max.	Pound feet min.	max.	Newton meters min.	max.
1/4	6.35	5	6	6.8	8.13	9	11	12.2	14.9	12	15	16.3	30.3
5/16	7.94	10	12	13.6	16.3	17	20.5	23.1	27.8	24	29	32.5	39.3
3/8	9.53	20	23	27.1	31.2	35	42	47.5	57.0	45	54	61.0	73.2
7/16	11.11	30	35	40.7	47.4	54	64	73.2	86.8	70	84	94.9	113.9
1/2	12.70	45	52	61.0	70.5	80	96	108.5	130.2	110	132	149.2	179.0
9/16	14.29	65	75	88.1	101.6	110	132	149.2	179.0	160	192	217.0	260.4
5/8	15.88	95	105	128.7	142.3	150	180	203.4	244.1	220	264	298.3	358.0
3/4	19.05	150	185	203.3	250.7	270	324	366.1	439.3	380	456	515.3	618.3
7/8	22.23	160	200	216.8	271.0	400	480	542.4	650.9	600	720	813.6	976.3
1	25.40	250	300	338.8	406.5	580	696	786.5	943.8	900	1080	1220.4	1464.5
1 1/8	25.58	-	-	-	-	800	880	1084.8	1193.3	1280	1440	1735.7	1952.6
1 1/4	31.75	-	-	-	-	1120	1240	1518.7	1681.4	1820	2000	2467.9	2712.0
1 3/8	34.93	-	-	-	-	1460	1680	1979.8	2278.1	2380	2720	3227.3	3688.3
1 1/2	38.10	-	-	-	-	1940	2200	2630.6	2983.2	3160	3560	4285.0	4827.4

\* Thick nuts must be used with grade 8 bolts.

Size of screw	Thread	Pitch (mm)	Grade 4T  				Grade 7T 				Grade 8T  			
			Torque				Torque				Torque			
			Pound feet min.	max.	Newton meters min.	max.	Pound feet min.	max.	Newton meters min.	max.	Pound feet min.	max.	Newton meters min.	max.
M6	UNC	1.00	3.6	5.8	4.9	7.9	5.8	9.4	7.9	12.7	7.2	10	9.8	13.6
M8	UNC	1.25	7.2	14	9.8	19	17	22	23	29.8	20	26	27.1	35.2
M10	UNC	1.5	20	25	27.1	33.9	34	40	46.1	54.2	38	46	51.5	62.3
M12	UNC	1.75	28	34	37.9	46.1	51	59	69.1	79.9	57	66	77.2	89.4
M14	UNC	2.0	49	56	66.4	75.9	81	93	109.8	126	96	109	130.1	147.7
M16	UNC	2.0	67	77	90.8	104.3	116	130	157.2	176.2	129	145	174.8	196.5
M18	UNC	2.0	88	100	119.2	136	150	168	203.3	227.6	175	194	237.1	262.9
M20	UNC	2.5	108	130	146.3	176.2	186	205	252	277.8	213	249	288.6	337.4
M8	UNF	1.0	12	17	16.3	23	19	27	25.7	36.6	22	31	29.8	42
M10	UNF	1.25	20	29	27.1	39.3	35	47	47.4	63.7	40	52	54.2	70.5
M12	UNF	1.25	31	41	42	55.6	56	68	75.9	92.1	62	75	84	101.6
M14	UNF	1.5	52	64	70.5	86.7	90	106	122	143.6	107	124	145	168
M16	UNF	1.5	69	83	93.5	112.5	120	138	162.6	187	140	158	189.7	214.1
M18	UNF	1.5	100	117	136	158.5	177	199	239.8	269.6	202	231	273.7	313
M20	UNF	1.5	132	150	178.9	203.3	206	242	279.1	327.9	246	289	333.3	391.6

Use the above torques when special torque is not given.

NOTE: These values apply to fasteners as received from supplier, dry, or when lubricated with normal engine oil. They do not apply if extreme pressure lubricants are used.

---

---

## **WARRANTY**

---

PRONOVOST warrants this product to the initial purchaser for the period of one year from the date of purchase against defects in materials and workmanship.

We will replace or repair defective parts free of charge if they are returned to our plant in St-Tite, Quebec, Canada.

Transportation charges are the responsibility of the customer. This warranty is not transferable.

Hydraulic cylinders are covered by the manufacturer of these items.

All PRONOVOST spare parts purchased are covered by a three (3) month warranty.

This warranty becomes void and nul if the equipment is modified, breaks down as the result of an accident, is not operated according to manufacturer's recommendations, damaged by negligence or if maintenance has not been carried out as specified.

Our obligation is limited to the replacement or repair of the defective part. PRONOVOST accepts no responsibility for direct or indirect consequential damages of any kind.



Ce manuel est aussi disponible en français.  
Veuillez téléphoner.



**INNOVATION - EXCELLENCE**

**LES MACHINERIES PRONOVOST INC.**  
260, route 159,  
Saint-Tite, Quebec, Canada, G0X 3H0  
Tel.: (418) 365-7551, Fax: (418) 365-7954  
E-mail: [info@pronovost.qc.ca](mailto:info@pronovost.qc.ca)  
Website: [www.pronovost.qc.ca](http://www.pronovost.qc.ca)