



**OPERATOR'S / PARTS
MANUAL**



Snowblowers
Models

P-920 & P-920TRC
P-920-98 & P-920TRC-98
P-98134 & P-98134TRC

VISIT OUR WEBSITE



www.pronovost.qc.ca

Copyright © Les Machineries Pronovost Inc., 2006

All rights reserved.
Printed in Canada.

TABLE OF CONTENTS

Section	Item	Page
1	Introduction	5
2	Safety	6
	General Safety	6
	Safety in Operation	6
	Safety with Maintenance	7
	Safety in Transport	7
	Safety in Storage	7
3	Decals	8
	Safety Decals	8
	Maintenance Decals	10
4	Assembly	12
	General assembly	12
5	Start-up	13
	Basic Start-up Procedures	13
6	Maintenance	14
7	Storage	16
8	Trouble Shooting	17
9	Specifications	19
10	Parts List	20
	Snowblower P-920 P-920-98	20
	Snowblower P-920TRC P-920TRC-98	23
	Snowblower P-98134	27
	Snowblower P-98134TRC	30
	Chute CST-7486	33
	Semi-industrial Chute PSIG-7486	35
	Industrial Chute PCG-7486	37
	Options	39
	P.T.O. Shaft 9225-EG 9225-1 9569	41
	P.T.O. Shaft 9475 9475-1 9475-2	42
	Gear box 9307	43
	Reducer 9575	44
	Cylinder 25TR08	45
	Hydraulic Motor MLH-250 & MLH-315	46
11	Torque Chart	47
12	Warranty	48

INTRODUCTION

CONGRATULATIONS!

Thank you for choosing PRONOVOST. We are confident this equipment will meet your requirements in terms of quality, performance and reliability.

This manual was prepared to assist you in the safe operation of your new Snowblower. It contains important information which will help you achieve excellent returns with your Snowblower for years to come.

Please read this manual completely before operating your Snowblower and keep it for future reference.

Before starting the machine, you or any other person who will be operating the Snowblower must familiarize yourself with the safety recommendations and the operating instructions. Please read carefully and be sure to understand and follow all recommendations and procedures.

In this manual, the right and left sides are identified as shown on Figure 1.

If you require additional information on your Snowblower, please contact your PRONOVOST Dealer.

NOW take a moment to enter the model, serial number and the date of purchase of your Snowblower in the space provided.

When ordering parts from your Dealer, please refer to these numbers for a fast and efficient service. Use PRONOVOST parts for replacement.

The model and serial numbers are on the name plate shown on Fig. 1.

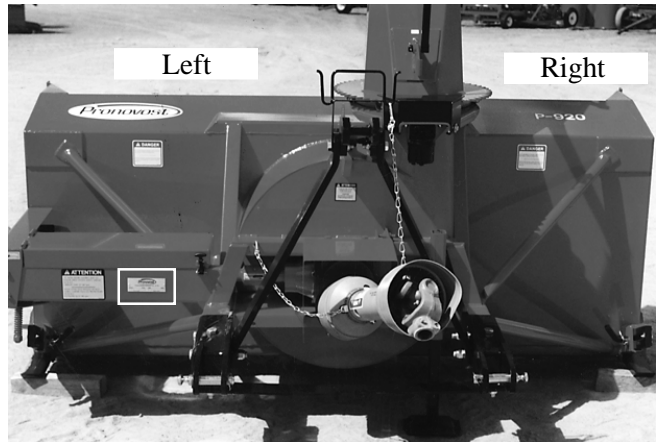

Figure 1

MODEL: _____

SERIAL NO: _____

DATE OF PURCHASE: _____

SAFETY

GENERAL SAFETY

2

WHEN YOU SEE THIS SYMBOL



ATTENTION!

**BE ALERT
YOUR SAFETY IS INVOLVED**

This symbol «**SAFETY ALERT**» is used in this manual and on the safety decals on the Snowblower. It warns you of the possibility of danger. Carefully read, understand and follow all safety recommendations before operating the Snowblower.

- 1) Careful operation is the best assurance against accidents. Carefully read this manual and follow all recommendations before operating your Snowblower. It is the owner's responsibility to make sure that anyone who will operate the Snowblower will read this manual before operating the equipment.
- 2) Familiarize yourself with all controls and always be ready to stop the Snowblower quickly in case of emergency.
- 3) Never let a child operate the Snowblower.
- 4) Do not modify the Snowblower. Any non authorized modification may affect the efficiency and/or safety of the equipment and will automatically void the warranty.
- 5) Never operate the Snowblower with defective parts or if damaged in any way. Have it repaired before operating.
- 6) Make sure all fasteners are in place and properly secured or tightened. Refer to torque chart on page 47.
- 7) Avoid wearing loose fitting clothing when working with the Snowblower. These could get entangled in moving parts of the equipment and cause accidents.

- 8) Prolonged exposure to noise may hamper hearing. Protect yourself by wearing adequate protection devices.
- 9) Hydraulic fluids under pressure can damage your skin. Do not use your hands to locate a leak.
- 10) Before the beginning of the snow season, inspect all areas where the Snowblower will be used and remove any object which may cause an accident and/or damage the equipment.
- 11) Never operate your Snowblower in poor visibility or without proper lighting conditions.

SAFETY IN OPERATION

- 1) Be sure there are no obstructions around the equipment and that no one stands near the equipment when in operation.
- 2) Do not operate an engine in a confined or non ventilated area.
- 3) Do not perform any adjustments, cleaning, maintenance or repairs with the engine running. The engine must be stopped and the P.T.O. disengaged. Preferably remove the key from the ignition.
- 4) Wear adequate clothing when working in cold or windy conditions.
- 5) Adjust skid shoes for proper ground clearance of scraper blade, especially in rough terrain or soft ground conditions.
- 6) Before operating, make sure the P.T.O. is properly installed and secured.
- 7) Before starting-up the Snowblower, make sure the auger and drum areas are free of ice.
- 8) Put P.T.O. control in neutral position before starting engine.
- 9) Keep hands, feet and clothing away from moving parts of the Snowblower. Stay away from the discharge chute.

SAFETY (cont'd)

- 10) Before unplugging the chute, always disengage the P.T.O., stop the engine and relieve all hydraulic pressures.
- 11) Do not operate in excessive inclined conditions. Be careful when turning in slopes.
- 12) Never operate your Snowblower with missing guards or without protective devices in place.
- 13) Do not operate your Snowblower near buildings, windows or other vehicles without prior and proper adjustment of the chute deflector.
- 14) Never aim discharge chute towards people or animals. This may cause serious injuries.
- 15) Always reduce operating speed in slippery conditions.
- 16) Be careful when backing-up, make sure you have good visibility.
- 17) Always be on the lookout for objects which may enter the Snowblower.
- 18) If undue vibrations are felt, disengage the P.T.O., stop the motor and look for the cause of the vibration. Vibration is usually the indication of a problem.
- 19) At the end of the operation, disengage the P.T.O., lower the Snowblower, put transmission in neutral, apply parking brake, stop engine and remove the key from the ignition.

SAFETY WITH MAINTENANCE

- 1) Perform the Snowblower maintenance according to recommendations contained in this manual.

- 2) Stop engine and relieve all hydraulic pressures before doing inspection, maintenance or repairs.
- 3) Never perform any work under the Snowblower while it is supported only by the tractor's hydraulic system. It must be completely supported by wooden blocks or other safe means.

SAFETY IN TRANSPORT

- 1) On public roads, use proper safety lights and check local regulations.
- 2) Be alert while driving on the road. Never carry passengers.
- 3) Always disengage P.T.O. while moving from one area of work to another.
- 4) It is recommended to use both brake pedals simultaneously for better control.
- 5) The recommended road speed should be such as to maintain full control over steering and braking.
- 6) Be careful while backing up, make sure you have good visibility.

SAFETY IN STORAGE

- 1) Provide adequate supports to prevent any accidental overturning of the Snowblower.
- 2) Do not let children play in the area where the snowblower is stored.

2

DECALS

SAFETY DECALS

The safety decals are affixed wherever special safety precautions are indicated. Locate them on the machine and read them carefully. If a decal is damaged, lost or illegible, install a new one. The following photos indicate where each one must be installed.

3

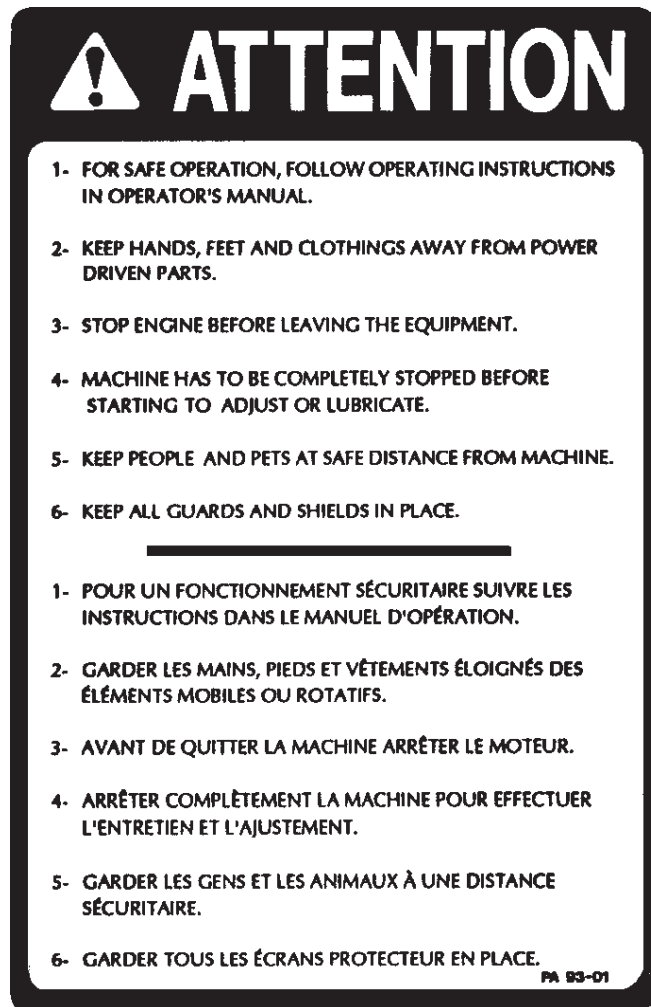

Figure 2
Decal A

Part no.: A102

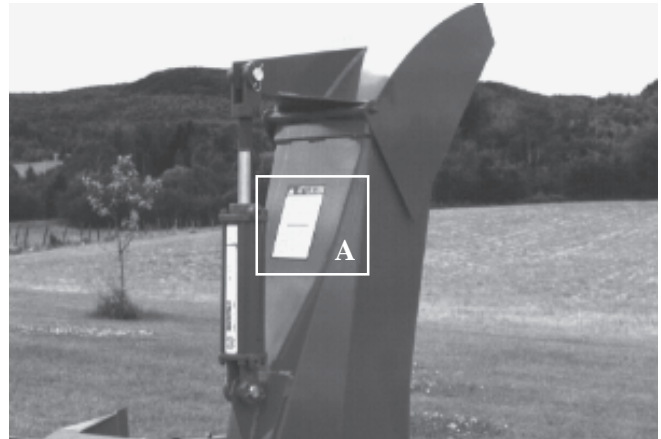

Figure 3



Figure 4
Decal B

Part no.: A101



Figure 5

DECALS (cont'd)

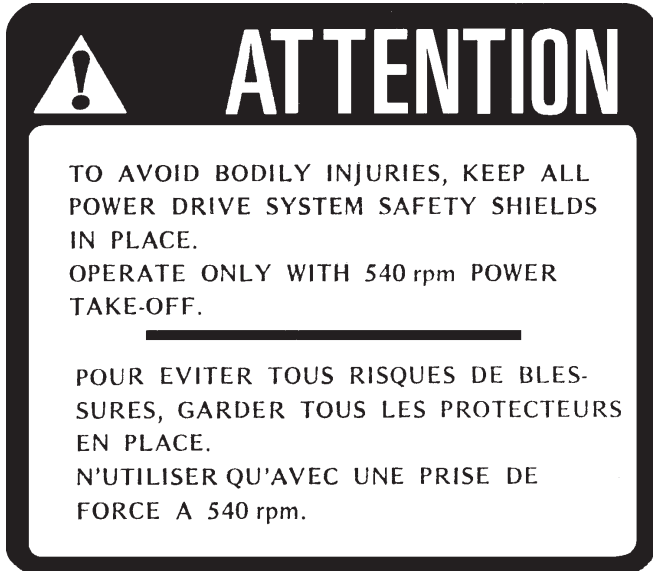

Figure 6
Decal C Part no.: A107



Figure 7
Decal D Part no.: A103

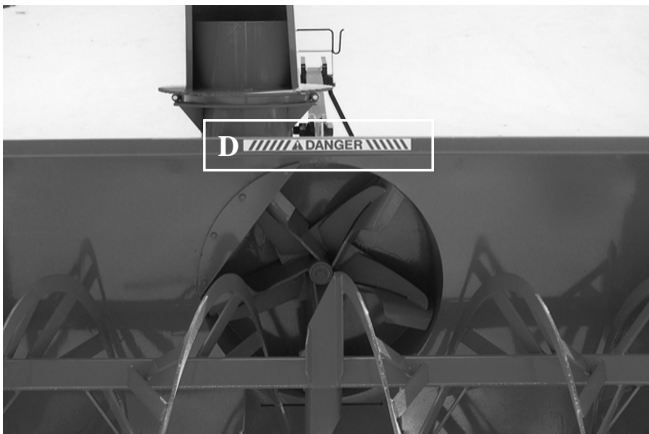

Figure 8

Decal E in Fig. 9 is located directly on the P.T.O. shaft. It is not visible when the safety shield is in place. It must never be visible when you operate the equipment.



Figure 9
Decal E Part no.: A108

3

DECALS (cont'd)

3



Figure 10
Decal F

Part no.: A 109

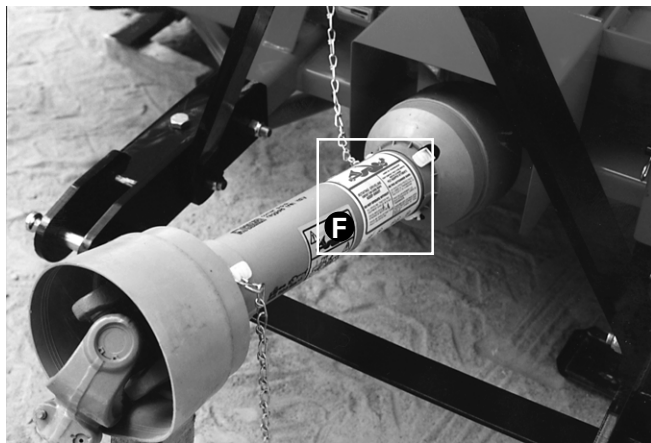
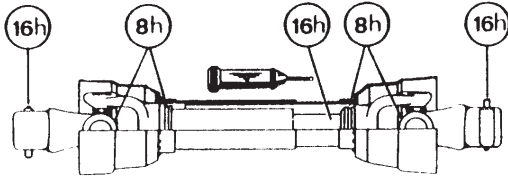

Figure 11

MAINTENANCE DECALS

The maintenance decals indicate the points requiring lubrication. Refer to maintenance section for more details.

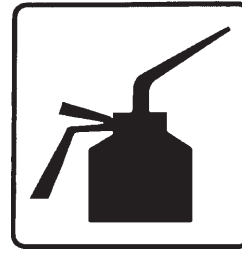

Figure 12

Part no.: A 105



Figure 13

Part no.: A 106



Figure 14
Decal G

Part no.: A104

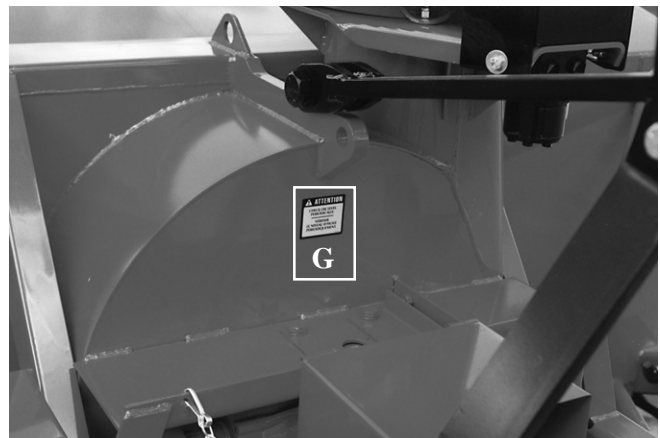

Figure 15

DECALS (cont'd)

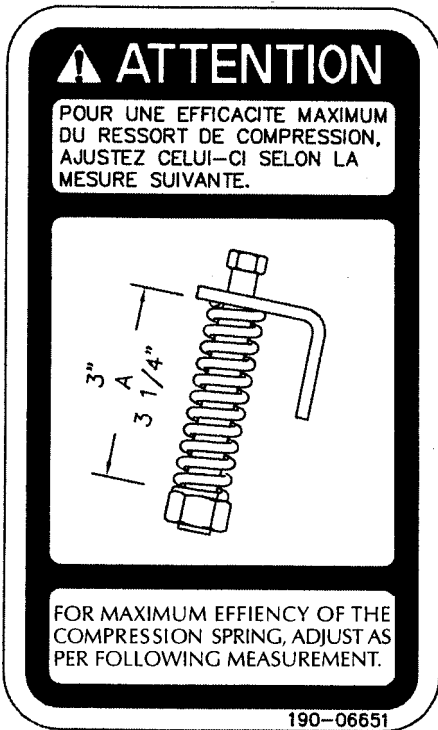

Figure 16
Decal H Part no.: 190-06651

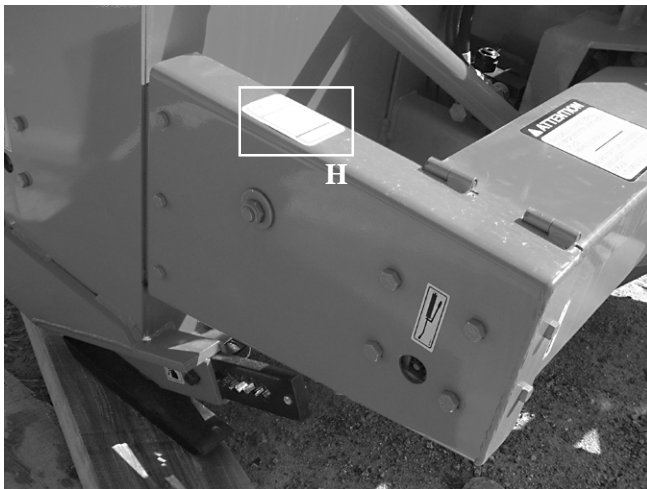

Figure 17

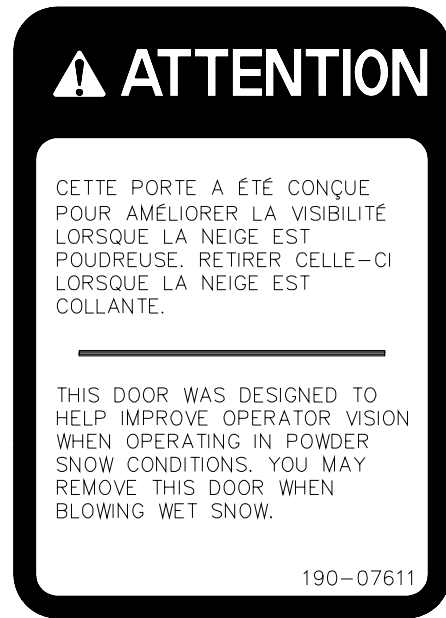

Figure 18
Decal J Part no.: 190-07611

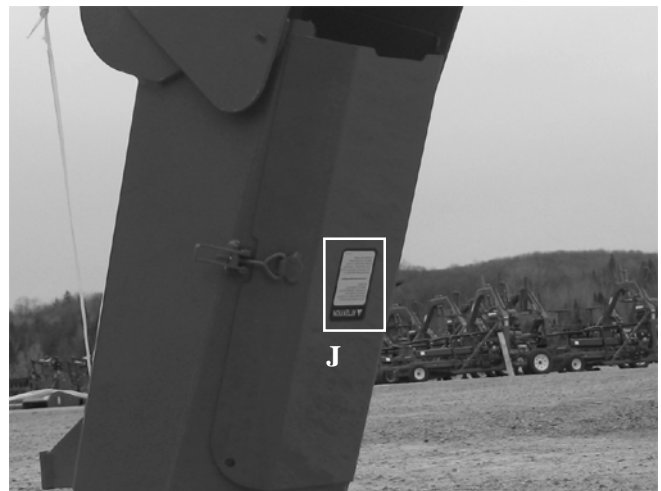

Figure 19

3

ASSEMBLY

4



Figure 18

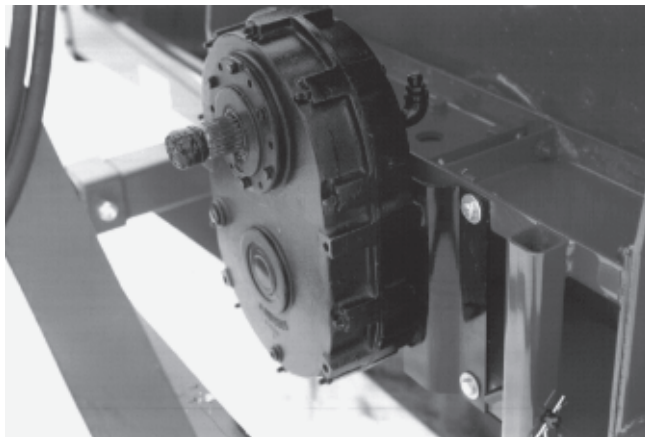

Figure 19

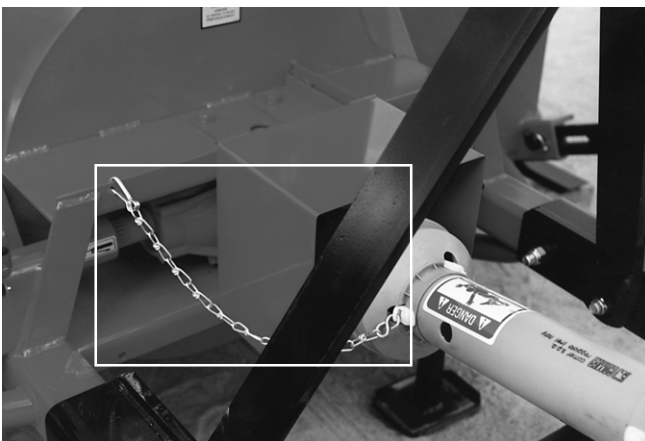

Figure 20

ASSEMBLY

- 1) The Snowblower is shipped partly assembled.
- 2) Install 3-point system according to the model of your Snowblower. (See section 10 for parts numbers). Use the holes most convenient to the type of tractor used (Fig. 18).
- 3) If your snowblower is equipped with the optional 1000 to 540 RPM reducer, install it on the gear box with the plate included (Fig. 19).
- 4) Install P.T.O. shaft with the shear pin end onto the Snowblower gear box. Then attach safety shield support chain as shown (Fig. 20). **WARNING:** The telescoping tubes of the drive shaft must never be allowed to bottom out while maintaining a minimum overlap of 6 inches.
- 5) If you install a hydraulic cylinder on the chute deflector, use model 25TR08 cylinder.
- 6) When installing chute, grease the groove of the UHMW slide in order to prevent the corrosion of the rim of the chute.
- 7) Install the chute rotation mechanism.

STARTING-UP

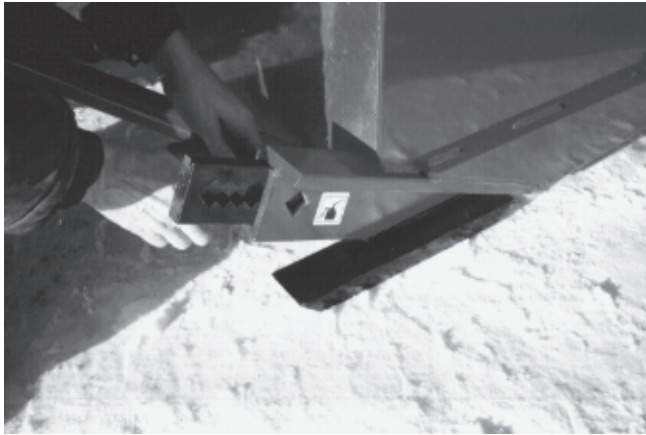

Figure 21

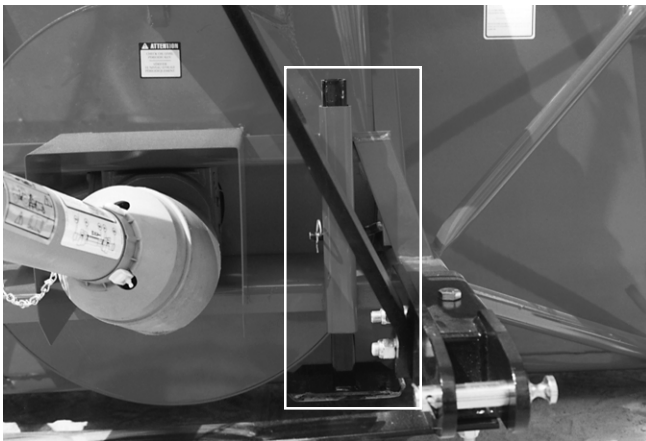

Figure 22



Figure 23

START-UP PROCEDURES

- 1) Check oil level in gearbox and in speed reducer if so equipped. Adjust to required oil level as per drawing in Parts List section. Use SAE 80W90 oil.
- 2) Lubricate all points with a good quality multipurpose grease.
- 3) Check chain take-up adjustment. The spring maintaining the tension must be compressed to a length between 3" and 3 1/4".
- 4) Verify for adequate tightness of all fastening devices. Refer to torque chart on page 47.
- 5) Adjust skid shoes according to ground conditions (Fig. 21).
- 6) Following the installation of the Snowblower on the tractor, **do not forget** to lift the storage support (Fig. 22).
- 7) Make sure of a 540 RPM input to your snowblower.
- 8) Check impeller adjustment. The tip of the blades should be approximately 1/8" to 3/16" from the discharge wall of the drum. If necessary, adjust with the take-up screws provided (Fig. 23).
- 9) In order to avoid damaging your snowblower, adjust the speed of descent of your 3 point hitch to prevent striking the ground too hard.
- 10) Adjust the hydraulic flow in order to have a good control of the rotation speed of the chute.

5

MAINTENANCE

- 1) Wipe off all grease fittings with a clean cloth before adding grease in order to avoid injecting dirt and sand.
- 2) Repair or replace damaged grease fittings.
- 3) Lubricate all grease fittings every 8 hours of operation.
- 4) Lubricate drive chain every 8 hours of operation.
- 5) Lubricate P.T.O. shaft as indicated below:

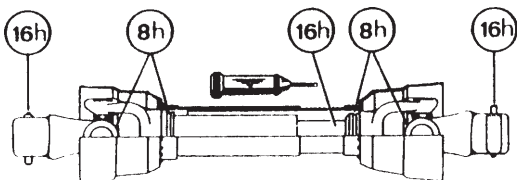

6 Pull out the P.T.O. and lubricate between the two tubes with low temperature grease. Drive line tubes must slide easily even in cold weather. Clean off old hardened grease and apply fresh grease as needed.

- 6) Check oil level in gear box once a month. Adjust to required oil level as per drawing in Parts List section. Use SAE 80W90 oil.
- 7) Check tension of drive chain every 24 hours of operation and adjust if necessary.
- 8) Check for tightness of bearing collars every 48 hours of operation.
- 9) Change gearbox oil once a year. Adjust to required oil level as per drawing in Parts List section. Use SAE 80W90 oil.

- 10) Check all nuts and bolts once a year. If necessary use torque chart on page 47.
- 11) Standard scraper blades are reversible. Reverse when one edge is worn out.
- 12) For the auger drive shaft, always use a grade 5 shear bolt.
- 13) For the PTO shaft, always use a grade 10.9 shear bolt at 540 RPM or a grade 8.8 shear bolt at 1000 RPM.
- 14) UHMW slides do not require lubrication except at the end of the season in order to prevent corrosion of steel components that are in contact with the UHMW material.

If your snowblower is equipped with the optional speed reducer

- 15) After 10 working hours, the chain's adjustment (if applicable) must be checked and every 100 working hours. Please refer to section: Maintenance on Speed Reducer (with chains).
- 16) Check oil level in speed reducer once a month. Adjust to required oil level as per drawing in Parts List section. Use SAE 80W90 oil.
- 17) Drain the oil of the speed reducer once a year. Adjust to required oil level as per drawing in Parts List section. Use SAE 80W90 oil.

MAINTENANCE ON SPEED REDUCER (with chain)

It is extremely important that the chain inside the chain box is **tightened**. A loose chain will add shocks to the entire box (chain, sprockets, bearings and spline couplings to gearbox).

Instructions for speed reducer (with chains) maintenance

This chain box has double functions.

- 1) Reduce angles at both ends of PTO in working position by increasing the input shaft height of 8".
- 2) Increase PTO capacity by increasing speed from 540 RPM to 1000 RPM.

PTO SHEAR BOLT

Because the PTO is running at 1000 RPM instead of 540 RPM, the shear bolt value must be changed. **AT 540 RPM** on a PTO size 80 or 90, the shear bolt is 12 mm, grade 10.9, part number **9207**.

AT 1000 RPM, the shear bolt must be changed depending on the diameter of the bore of the shear plate of your drive line:

- a) If the bore is 12 mm, you must use a 12 mm, grade 8.8 bolt that has been reduced to 10 mm at the point of rupture. part number **9207-375**, or
- b) If the bore is 10 mm, vous devez you must use a 10 mm, grade 8.8 bolt, part number **8218**.

ADJUSTMENT OF THE CHAIN'S TENSION

After 10 working hours, the chain's adjustment must be checked. In order to do so, verify the backlash between the input and the output shaft by turning the input shaft in both directions while the output shaft remains still. If there is a play of 10° or more, the chain must then be readjusted as follows:

- 1) Remove PTO from the chain box.
- 2) Unscrew the 12 bolts 5/16" dia. (item #22) from covers (items #7 and #15) around the input shaft on both sides of the chain box (6 bolts on each side).
NOTE: Input shaft covers are eccentric with outside of covers. Therefore by turning input shaft cover, center to center distance of shafts will be changed and thus, this will adjust the chain's tension.
- 3) With a hammer and a screw-driver or a chisel, gently turn both covers in the same direction until the next hole of the cover is in line with the threaded hole of the chain box.
IMPORTANT: Make sure that the covers are turned in the same direction and by the same number of holes. Otherwise, both shafts will not be parallel and serious damages might arise.
- 4) Verify the backlash between both shafts, as described above. If the difference is too high, repeat the operation explained in point 3. If the backlash is correct, reinstall the bolts and the PTO.
- 5) Verify the backlash every 100 working hours.

MAINTENANCE ON SPEED REDUCER

- 1) Check oil level in speed reducer once a month. Adjust to required oil level as per drawing in Parts List section. Use SAE 80W90 oil.
- 2) Drain the oil of the speed reducer once a year. Adjust to required oil level as per drawing in Parts List section. Use SAE 80W90 oil.

6

STORAGE

- 1) Store the Snowblower in a cool, dry place.
- 2) Support the Snowblower with wooden blocks.
- 3) Keep all piston rods in the retracted position. This will assure better protection against the elements.
- 4) Clean your Snowblower.
- 5) Thoroughly inspect all parts of the Snowblower. Replace or repair worn or defective parts.
- 6) Touch-up or repaint if necessary.
- 7) Lubricate all points before storage.

TROUBLESHOOTING

P.T.O. SHAFT

PROBLEM	POSSIBLE CAUSE	CORRECTION
<ul style="list-style-type: none"> - Premature wear of U-joints and/ or bluish color of cross journals. 	<ul style="list-style-type: none"> - Insufficient lubrication. - Excessive working angle. 	<ul style="list-style-type: none"> - Follow lubrication recommendations. - Replace defective U-joints. - Make sure the snowblower inlet face is perpendicular to the ground and if possible readjust 3-point hitch in order to position the snowblower further away from tractor.
<ul style="list-style-type: none"> - Gripping or premature wear of telescoping members. 	<ul style="list-style-type: none"> - Too much sliding under load. - Tube overlap too-short: minimum recommended is 6". - Insufficient lubrication. - Contaminants (sand, etc.). 	<ul style="list-style-type: none"> - Avoid raising snowblower while in operation. - Readjust 3-point hitch in order to position the snowblower closer to the tractor. - Follow lubrication recommendations. - Replace defective telescopic members.
<ul style="list-style-type: none"> - Damaged or jammed locking pin or bolt. 	<ul style="list-style-type: none"> - Pin or orifice contaminated by sand, ice, etc. - Telescoping members too long, exerting pressure on locking device. 	<ul style="list-style-type: none"> - Clean and grease. - Readjust 3-point hitch in order to position the snowblower further away from tractor.
<ul style="list-style-type: none"> - Premature wear of guard tube bearing ring. 	<ul style="list-style-type: none"> - Lack of lubrication. - Wrong installation of guard chain. - Part of the guard in contact with the equipment. 	<ul style="list-style-type: none"> - Follow lubrication instructions. - Adjust chain to prevent interference between guard & equipment. - Replace worn or damaged bearing rings.
<ul style="list-style-type: none"> - Cut or deformed safety guard tubes. 	<ul style="list-style-type: none"> - Tubes in contact with the equipment. 	<ul style="list-style-type: none"> - Eliminate any interference between tubes and equipment or tractor. - Replace damaged tubes.

TROUBLESHOOTING (cont'd)

SNOWBLOWER

PROBLEM	POSSIBLE CAUSE	CORRECTION
- The snow is not being thrown as far as usual.	<ul style="list-style-type: none"> - Tractor RPM too low. - Gap too wide between impeller blade tip and drum outlet wall. - Insufficient tractor HP. 	<ul style="list-style-type: none"> - Raise P.T.O. speed to a minimum of 540 RPM. - Adjust impeller blades closer to drum outlet (1/8" to 3/16"). - Reduce travel speed.
- Frequent plugging of discharge chute.	<ul style="list-style-type: none"> - Tractor RPM too low. - Tractor RPM reduced too early with snow still in the Snowblower. - Slippage of PTO clutch mechanism. - Wet snow condition. 	<ul style="list-style-type: none"> - Raise P.T.O. speed to a minimum of 540 RPM. - Make sure the Snowblower is completely empty before reducing RPM, especially on tractors with foot controlled RPM. - Repare clutch. - Reduce travel speed. - Remove the chute access panel.
- The impeller will not turn.	<ul style="list-style-type: none"> - Shear bolt broken on drive shaft. 	<ul style="list-style-type: none"> - Replace shear bolt.
- The auger will not turn.	<ul style="list-style-type: none"> - Shear bolt broken on drive shaft. - Shear bolt broken on auger drive shaft. - Broken drive chain. - Broken key on motor. 	<ul style="list-style-type: none"> - Replace shear bolt. - Replace shear bolt. - Fix or replace chain. - Replace the key.
- The rotating drum will not turn.	<ul style="list-style-type: none"> - Ice accumulation. - Wrong hydraulic connections. 	<ul style="list-style-type: none"> - Remove ice. - Check hydraulic connections.
- The rotating drum will not hold it's position when blowing via the spout	<ul style="list-style-type: none"> - Cushion valve setting too low - Tension of the spring in drum locking mechanism insufficient 	<ul style="list-style-type: none"> - Reset cushion valve up to 1800 psi (max) - Increase tension of spring by adding shim(s)
- The chute will not turn.	<ul style="list-style-type: none"> - Ice accumulation. - Wrong hydraulic connections. - Broken key on motor. 	<ul style="list-style-type: none"> - Remove ice. - Check hydraulic connections. - Replace the key.

8

SPECIFICATIONS

		GROUP II		
Snowblower model		P-920	P-920 -98	P-98134
Snowblower model		P-920 TRC	P-920 TRC-98	P-98134 TRC
Horse power recommended (HP)	min.-max.	75 to 100	75 to 100	90 to 125
Working width	po. - (cm)	92"(234)	98" (249)	98" (249)
Cutting height	po. - (cm)	39" (99)	39" (99)	40" (102)
Height - chute base	po. - (cm)	42 1/8" (107.0)	42 1/8" (107.0)	43 1/8" (110)
Height - chute base, TRC model	po. - (cm)	44 11/16" (113.5)	44 11/16" (113.5)	47 1/4" (120)
Impeller diameter	po. - (cm)	30" (76)	30" (76)	34" (86)
Depth of drum	po. - (cm)	12" (30.5)	12" (30.5)	12" (30.5)
Impeller blades		5	5	5
Size of impeller shaft	po. - (cm)	2"	2"	2"
Height - Impeller center	po. - (cm)	20" (50.8)	20" (50.8)	21" (53)
Impeller RPM		540	540	540
Number of augers		1	1	1
Main auger diameter	po. - (cm)	23" (58)	23" (58)	23" (58)
Upper auger 13"/33 cm dia.		-	-	-
Drive chain - main auger		80	80	80
Oil bath sealed gear box		Std.	Std.	Std.
Chute rotation mechanism	Manual	-	-	-
	Hydraulic (motor)	Std.	Std.	Std.
Number of shear bolts		2	2	2
Hitch category		2	2	2
Balanced impeller		Std.	Std.	Std.
Balanced auger		Std.	Std.	Std.
Drum rotation for hydraulic motor		Std.	Std.	Std.
1000 to 540 RPM reducer		Opt.	Opt.	Opt.
Scrapper blades	Standard steel - not rev.	-	-	-
	Standard steel - rev.	Std.	Std.	Std.
	Carbon steel 1/2" x 3"	-	-	-
	Carbon steel 1/2" x 4"	Opt.	Opt.	Opt.
	Carbon steel 1/2" x 6"	Opt.	Opt.	Opt.
	Tivar	Opt.	Opt.	Opt.
	Stainless steel 1/2" x 3"	-	-	-
	Stainless steel 1/2" x 4"	Opt.	Opt.	Opt.
Adjustable skid shoes	Standard steel	Std.	Std.	Std.
	Carbon steel	Opt.	Opt.	Opt.
	Stainless steel	Opt.	Opt.	Opt.
Full flight auger (industrial)		Opt.	Opt.	Opt.
Chute	regular	Opt.	Opt.	Opt.
	semi-industrial	Opt.	Opt.	Opt.
	quick attach indust.	Opt.	Opt.	Opt.
	- extension 24" or 48"	Opt.	Opt.	Opt.
	industrial telescopic	-	-	-
Deflector	manual	Opt.	Opt.	Opt.
	hydraulic	Opt.	Opt.	Opt.
Bearing / ductile iron casting		Std.	Std.	Std.
Lateral blades		Opt.	Opt.	Opt.
P.T.O.	(standard)	No. 8	No. 8	No. 8
P.T.O.	(optional)	No. 9	No. 9	No. 9
Weight	lbs - kg	1650 (748)	1725 (781)	1880 (855)
	lbs - kg	1800 (816)	1875 (848)	2030 (922)

Design and specifications subject to change without notice.

Shaded lines apply only to models with rotary drum (TRC).

SNOWBLOWER P-920 P-920-98

170-03891R1

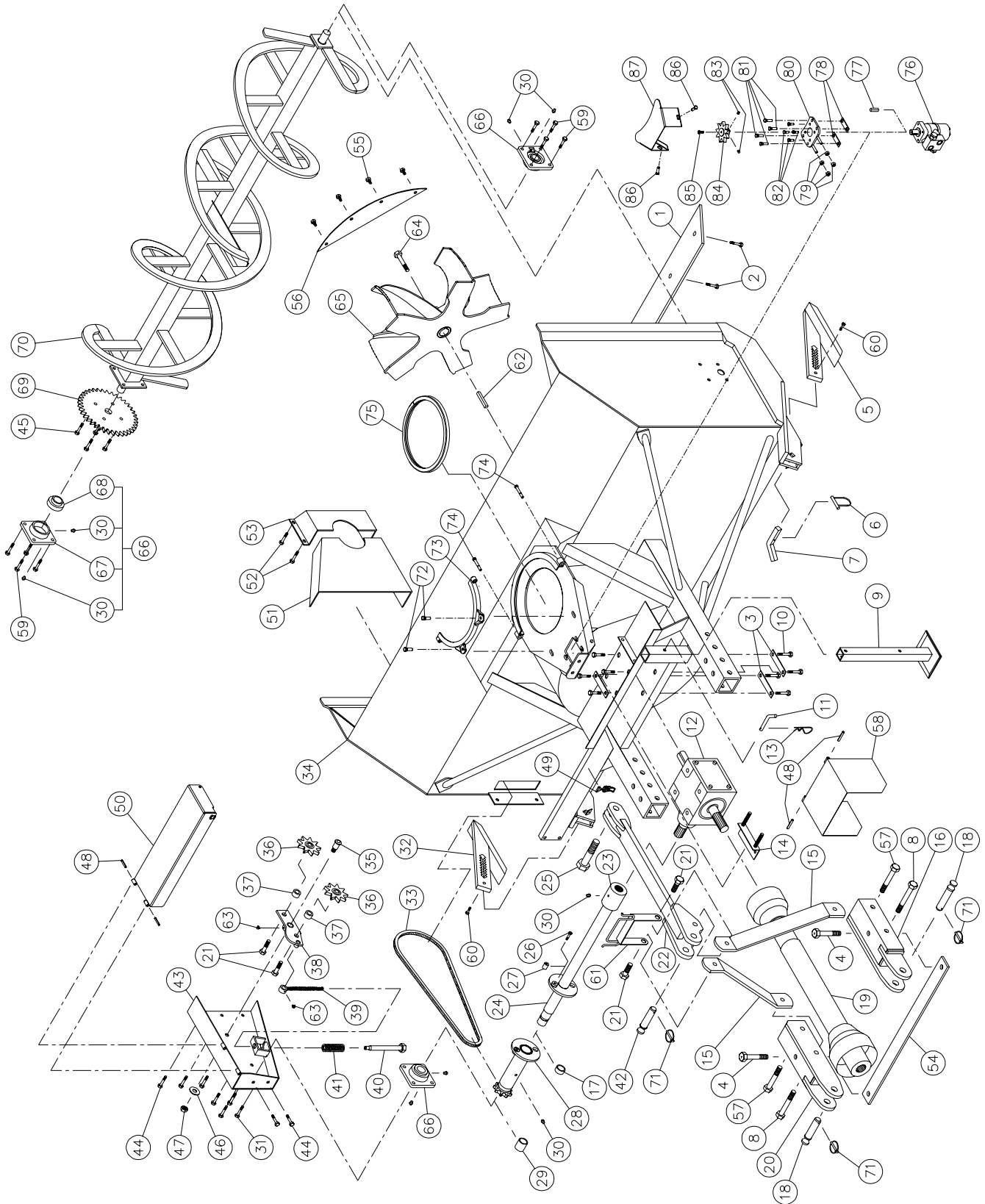

10

SNOWBLOWER P-920 P-920-98 (cont'd)

REF.	PART #	DESCRIPTION	QTY	
			P-920	P-920-98
1	140-00812	Reversible scraper blade 1/2" x 4" x 84½" lg	1	-
1	140-00832	Reversible scraper blade 1/2" x 4" x 90½" lg	-	1
2	319-38325	Plow bolt 7/16" x 1¾" lg + nut & lock washer	9	9
3	140-10761	Back plate	3	3
4	302-46550	Bolt 3/4" NF x 5 1/2" lg + nylon locknut	2	2
5	110-04531	Skid shoe (right side)	1	1
6	8112	Lock pin 1/4"	2	2
7	140-03361	Skid shoes lock	2	2
8	302-46610	Bolt 3/4" NF x 6 1/2" lg + nylon lock nut	2	2
9	9462	Storage support	1	1
10	300-44280	Bolt 5/8" NC x 1 1/4" lg + lock washer + 6 flat washers	8	8
11	8220	Storage support pin	1	1
12	9307	Gear box	1	1
13	Std.	Hitch pin clip 5/32"	1	1
14	9428	Adjustment plate for gear box + 4 nuts 1/2" NC	1	1
15	140-05493	3-points side bar	2	2
16	110-15214	Right lower hitch	1	1
17	160-06901	Aluminium-bronze bushing 1 3/4" i.d. x 2" o.d. x 1/2" lg	1	1
18	9269	Pin category 2 (1 1/8" diameter)	2	2
19	9225-EG	P.T.O. shaft T80	1	1
19	9475	P.T.O. shaft T90	opt.	opt.
20	110-15213	Left lower hitch	1	1
21	300-46400	Bolt 3/4" NC x 3" lg + nylon lock nut	4	4
22	110-15421	Upper hitch	1	1
23	6467	Splined adaptor 1¾"-20 (welded)	1	1
24	110-18251	Auger drive shaft 34 7/16" lg overall (includes no. 23 and 27)	1	-
24	110-18261	Auger drive shaft 37 7/16" lg overall (includes no. 23 and 27)	-	1
25	300-54460	Bolt 1 1/4" NC x 4" lg + nylon lock nut	1	1
26	300-34340	Bolt 5/16" NC x 2" lg grade 5 + nylon lock nut	1	1
27	150-03911	Bushing 5/16" i.d. x 1" o.d. x ¾" lg (welded)	2	2
28	110-18241	Sprocket #80 + shearplate (includes no. 17 & 29)	1	1
29	160-07311	Aluminium-bronze bushing 1 1/2" i.d. x 1 7/8" o.d. x 1 1/4" lg	1	1
30	Std.	Grease fitting ¼"-28 straight	8	8
31	300-40310	Bolt 1/2" NC x 1 1/2" lg + nylon locknut (thin)	4	4
32	110-04521	Skid shoe (left side)	1	1
33	190-00431	Chain #80 x 79" lg (79 links)	1	1
33	26A80	Connecting link #80	1	1
33	59-80	Offset link #80	1	1
34	120-02796	Frame P-920	1	-
34	120-02816	Frame P-920-98	-	1
35	150-00332	Idler clevis pin	1	1
36	9287	Idler sprocket #80 (steel)	2	2
37	160-06511	Spacer 3/4" i.d. x 1 1/4 o.d. x 3/4" lg	2	2
38	110-01052	Idler	1	1
39	110-01063	Threaded rod for idler adjustment + nut 7/16" NC	1	1
40	110-01071	Threaded tube for idler adjustment	1	1
41	9688	Compression spring	1	1
42	150-05961	Pin category 2 (1" diameter) (top link)	1	1
43	110-10564	Chain guard	1	1
44	301-38250	Bolt 7/16" NC x 1" lg + nylon locknut	5	5
45	301-38310	Bolt 7/16" NC x 1½" lg + two-way locknut	4	4
46	376-44000	Flat washer 5/8"	1	1
47	346-45000	Nylon locknut 5/8" NC thin	1	1

SNOWBLOWER P-920 P-920-98 (cont'd)

REF.	PART #	DESCRIPTION	QTY	
			P-920	P-920-98
48	Std.	Roll pin 5/16" x 2" lg	4	4
49	8374	Adjustable clamp fastener (welded)	1	1
50	110-21001	Side shaft guard for P-920	1	-
50	110-27621	Side shaft guard for P-920-98	-	1
51	130-01382	Inside guard (welded)	1	1
52	301-36250	Bolt 3/8" NC x 1" lg + nylon lock nut & flat washer	4	4
53	8925	Inside guard (bolted)	1	1
54	140-03441	Brace 3/8" x 2 1/2" x 38 1/4"	1	1
55	301-38280	Bolt 7/16" NC x 1 1/4" lg + nylon locknut	4	4
56	130-02111	Deflector	1	1
57	302-46580	Bolt 3/4" NF x 6" lg + nylon locknut	2	2
58	110-12541	Hinged P.T.O. shroud	1	1
59	300-40325	Bolt 1/2" NC x 1 3/4" lg + nylon locknut	8	8
60	300-32310	Bolt 1/4" NC x 1 1/2" lg + nylon locknut	2	2
61	110-15201	Hoses support	1	1
62	9285	Square key 1/2" x 1/2" x 4" lg	1	1
63	Std.	Grease fitting 1/4" - 28 90 deg.	2	2
64	300-44310	Impeller cap screw 5/8" x 1 1/2" lg (ass. with lock-tite 242) + lock washer	1	1
65	110-04742	Impeller 30" ø 5 blades	1	1
66	UCFD208-24	Bearing 1 1/2" + flange + 2 straight grease fitting	3	3
67	FD208	Flange for 2 grease fitting	3	3
68	UC208-24	Bearing 1 1/2"	3	3
69	9281	Sprocket 80A30 T 1 1/2" ø	1	1
70	110-02061	Auger P-920	1	-
70	110-05171	Aufger P-920-98	-	1
71	Std.	Linch pin 1/4" x 1 3/4"	3	3
72	300-40310	Bolt 1/2" NC x 1 1/2" lg + nylon locknut & flat washer	2	2
73	110-01341	Retaining bracket	1	1
74	300-38400	Bolt 7/16" NC x 3" lg + nylon locknut	2	2
75	8149	U-shaped UHMW approx 14" interior dia.	1	1
76	MLH 315	"Orbit" hydraulic motor + cushion valve	opt.	opt.
77	8369	"Key" for hydraulic motor	opt.	opt.
78	140-09571	Spacer 1/8" x 1" x 3 1/4" lg for hydraulic motor	2	2
79	336-38000	Nut 7/16" NC	4	4
80	110-20811	Hydraulic motor support	1	1
81	300-38310	Bolt 7/16" NC x 1 1/2" lg + nylon locknut & flat washer	4	4
82	300-36250	Bolt 3/8" NC x 1" lg + lock washer	4	4
83	323-36160	Hexagonal socket set screw 3/8" NC x 3/8" lg	2	2
84	110-04182	Sprocket 9 teeth	1	1
85	300-32220	Bolt 1/4" NC x 3/4" lg + lock washer	1	1
86	300-38280	Bolt 7/16" NC x 1 1/4" lg + nylon locknut & flat washer	2	2
87	130-29491	Guard	1	1

SNOWBLOWER P-920TRC P-920TRC-98

170-03901R1

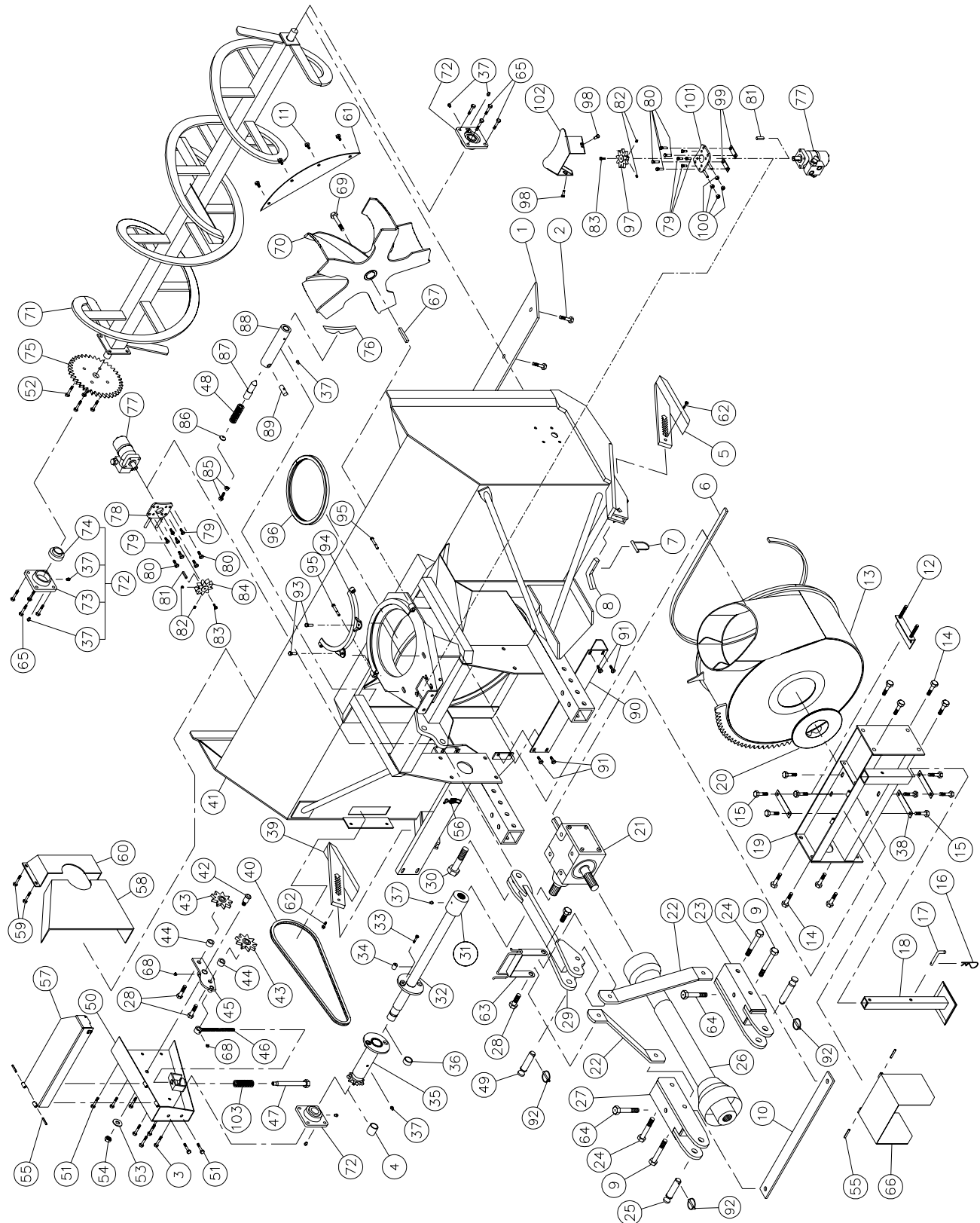

SNOWBLOWER P-920TRC P-920TRC-98 (cont'd)

REF.	PART #	DESCRIPTION	QTY	
			P-920TRC	P-920TRC-98
1	140-00812	Reversible scraper blade 1/2" x 4" x 84 1/2" lg	1	
1	140-00832	Reversible scraper blade 1/2" x 4" x 90 1/2" lg	-	1
2	319-38325	Plow bolt 7/16" NC x 1 3/4" lg + nut & lock washer	9	9
3	301-40310	Bolt 1/2" NC x 1 1/2" lg + nylon locknut (thin)	4	4
4	160-07311	Aluminium-bronze bushing 1 1/2" i.d. x 1 7/8" o.d. x 1 1/4" lg	1	1
5	110-04531	Skid shoe (right side)	1	1
6	9435	U-shaped UHMW 3/8" x 7/8" x 97" lg	1	1
7	8112	Lock pin 1/4"	2	2
8	140-03361	Skid shoes lock	2	2
9	302-46610	Bolt 3/4" NF x 6 1/2" lg + nylon lock nut	2	2
10	140-03441	Brace 3/8" x 2 1/2" x 38 1/4"	1	1
11	301-38280	Bolt 7/16" NC x 1 1/4" lg + nylon locknut	4	4
12	9428	Adjustment plate for gear box + 4 nuts 1/2" NC	1	1
13	110-12613	Rotary drum 30" ø x 12" depth	1	1
14	301-46340	Bolt 3/4" NC x 2" lg + nylon lock nut	8	8
15	300-44280	Bolt 5/8" NC x 1 1/4" lg + lock washer	8	8
16	Std.	Hitch pin clip 5/32"	1	1
17	8220	Storage support pin	1	1
18	9462	Storage support	1	1
19	110-01682	Gear box support	1	1
20	9432	UHMW flat washer 3/16" x 8 7/8" i.d. x 12" o.d.	1	1
21	9307	Gear box	1	1
22	140-05472	3-points side bar	2	2
23	110-15214	Right lower hitch	1	1
24	301-46580	Bolt 3/4" NC x 6" lg + nylon lock nut	2	2
25	9269	Pin category 2 (1 1/8" diameter)	2	2
26	9225-EG	P.T.O. shaft T80	1	1
26	9475	P.T.O. shaft T90	opt.	opt.
27	110-15213	Left lower hitch	1	1
28	302-46400	Bolt 3/4" NC x 3" lg + nylon lock nut	4	4
29	110-15311	Upper hitch	1	1
30	300-54460	Bolt 1 1/4" NC x 4" lg + nylon lock nut	1	1
31	6467	Splined adaptor 1 3/4" - 20 splines (welded)	1	1
32	110-18251	Auger drive shaft 34 7/16" lg overall (includes no. 31 and 34)	1	-
32	110-18261	Auger drive shaft 37 7/16" lg overall (includes no. 31 and 34)	-	1
33	301-34340	Bolt 5/16" NC x 2" lg grade 5 + nylon locknut	1	1
34	150-03911	Bushing 5/16" i.d. x 1" o.d. x 3/4" lg (welded)	2	2
35	110-18241	Sprocket #80 + shearplate (includes no. 36 & 105)	1	1
36	160-06901	Aluminium-bronze bushing 1 3/4" i.d. x 2" o.d. x 1/2" lg	1	1
37	Std.	Grease fitting 1/4"-28 straight	9	9
38	140-10761	Back plate	3	3
39	110-04521	Skid shoe (left side)	1	1
40	190-00431	Chain #80 x 79" lg (79 links)	1	1
40	26A80	Connecting link #80	1	1
40	59-80	Offset link #80	1	1
41	120-02855	Frame P-920TRC	1	-
41	120-02835	Frame P-920-98TRC	-	1
42	150-00332	Idler clevis pin	1	1
43	9287	Idler sprocket #80	2	2
44	160-06511	Spacer 3/4" i.d. x 1 1/4" o.d. x 3/4" lg	2	2
45	110-01052	Idler	1	1

SNOWBLOWER P-920TRC P-920TRC-98 (cont'd)

REF.	PART #	DESCRIPTION	QTY	
			P-920TRC	P-920TRC-98
46	110-01063	Threaded rod for idler adjustment + nut 7/16" NC	1	1
47	110-01071	Threaded tube for idler adjustment	1	1
48	9473	Compression spring (black)	1	1
49	150-05961	Pin category 2 (1" diameter) (top link)	1	1
50	110-10564	Chain guard	1	1
51	301-38250	Bolt 7/16" NC x 1" lg + nylon lock nut	5	5
52	301-38310	Bolt 7/16" NC x 1 1/2" lg + two-way locknut	4	4
53	376-40000	Flat washer 5/8"	1	1
54	346-45000	Nylon locknut 5/8" NC thin	1	1
55	Std.	Roll pin 5/16" x 2" lg	4	4
56	8374	Adjustable clamp fastener (welded)	1	1
57	110-21011	Side shaft guard for P-920TRC	1	-
57	110-28071	Side shaft guard for P-920TRC-98	-	1
58	130-01382	Inside guard (welded)	1	1
59	300-36250	Bolt 3/8" NC x 1" lg + nylon locknut & flat washer	4	4
60	8925	Inside guard (bolted)	1	1
61	130-02111	Deflector	1	1
62	300-32310	Bolt 1/4" x 1 1/2" lg + nylon locknut	2	2
63	110-15201	Hoses support	1	1
64	302-46550	Bolt 3/4" NF x 5 1/2" lg + nylon locknut	2	2
65	300-40325	Bolt 1/2" NC x 1 3/4" lg + nylon locknut	8	8
66	110-12541	Hinged P.T.O. shroud	1	1
67	9285	Square key 1/2" x 1/2" x 4" lg	1	1
68	Std.	Grease fitting 1/4" - 28 90 deg.	2	2
69	300-44310	Impeller cap screw 5/8" NC x 1 1/2" lg (ass. with lock-tite 242) + lock washer	1	1
70	110-04742	Impeller 30" ø 5 blades	1	1
71	110-02061	Auger P-920	1	-
71	110-05171	Auger P-920-98	-	1
72	UCFD208-24	Bearing 1 1/2" + flange + 2 straight grease fitting	3	3
73	FD208	Flange for 2 grease fitting	3	3
74	UC208-24	Bearing 1 1/2"	3	3
75	9281	Sprocket 80A30 T 1 1/2" ø	1	1
76	130-29521	Stop block for drum lock (welded on drum)	1	1
77	MLH-315	Hydraulic motor "Orbit"	opt.	opt.
78	110-18441	"Orbit" motor support + 4 nut 7/16" NC	1	1
79	300-36250	Bolt 3/8" x 1" lg + lock washer	8	8
80	300-38310	Bolt 7/16" NC x 1 1/2" lg + nylon locknut & flat washer	8	8
81	8369	Key for "Orbit" motor	opt.	opt.
82	323-36160	Hexagonal socket set screw 3/8" NC x 3/8" lg	4	4
83	300-32220	Bolt 1/4" NC x 3/4" lg + lock washer	2	2
84	110-04721	Sprocket 9 teeth	1	1
85	300-38330	Bolt 7/16" NC x 1 3/4" lg (full length thread) + lock nut	1	1
86	130-08471	Washer	1	1
87	150-01542	Latch pin - drum lock	1	1
88	160-03952	Body - drum lock (welded on frame)	1	1
89	150-02561	Pin	1	1
90	130-29471	Guard for ring gear segment	1	1
91	300-40280	Bolt 1/2" NC x 1 1/4" lg + nylon locknut + flat washer	4	4
92	Std.	Lynch pin 1/4" x 1 3/4" lg	3	3
93	300-40310	Bolt 1/2" NC x 1 1/2" lg + nylon locknut & flat washer	2	2
94	110-01341	Retaining bracket	1	1
95	300-38400	Bolt 7/16" NC x 3" lg + nylon locknut	2	2

SNOWBLOWER P-920TRC P-920TRC-98 (cont'd)

REF.	PART #	DESCRIPTION	QTY	
			P-920TRC	P-920TRC-98
96	8149	U-shaped UHMW approx. 14" interior dia.	1	1
97	110-04182	Sprocket 9 tooth.....	1	1
98	300-38280	Bolt 7/16" NC x 1 1/4" lg + nylon locknut & flat washer	2	2
99	140-09571	Spacer 1/8" x 1" x 3 1/4" lg for "Orbit" motor	2	2
100	336-38000	Nut 7/16" NC	4	4
101	110-20811	Hydraulic motor support	1	1
102	130-29491	Guard	1	1
103	9688	Compression spring	1	1

SNOWBLOWER P-98134

170-04231

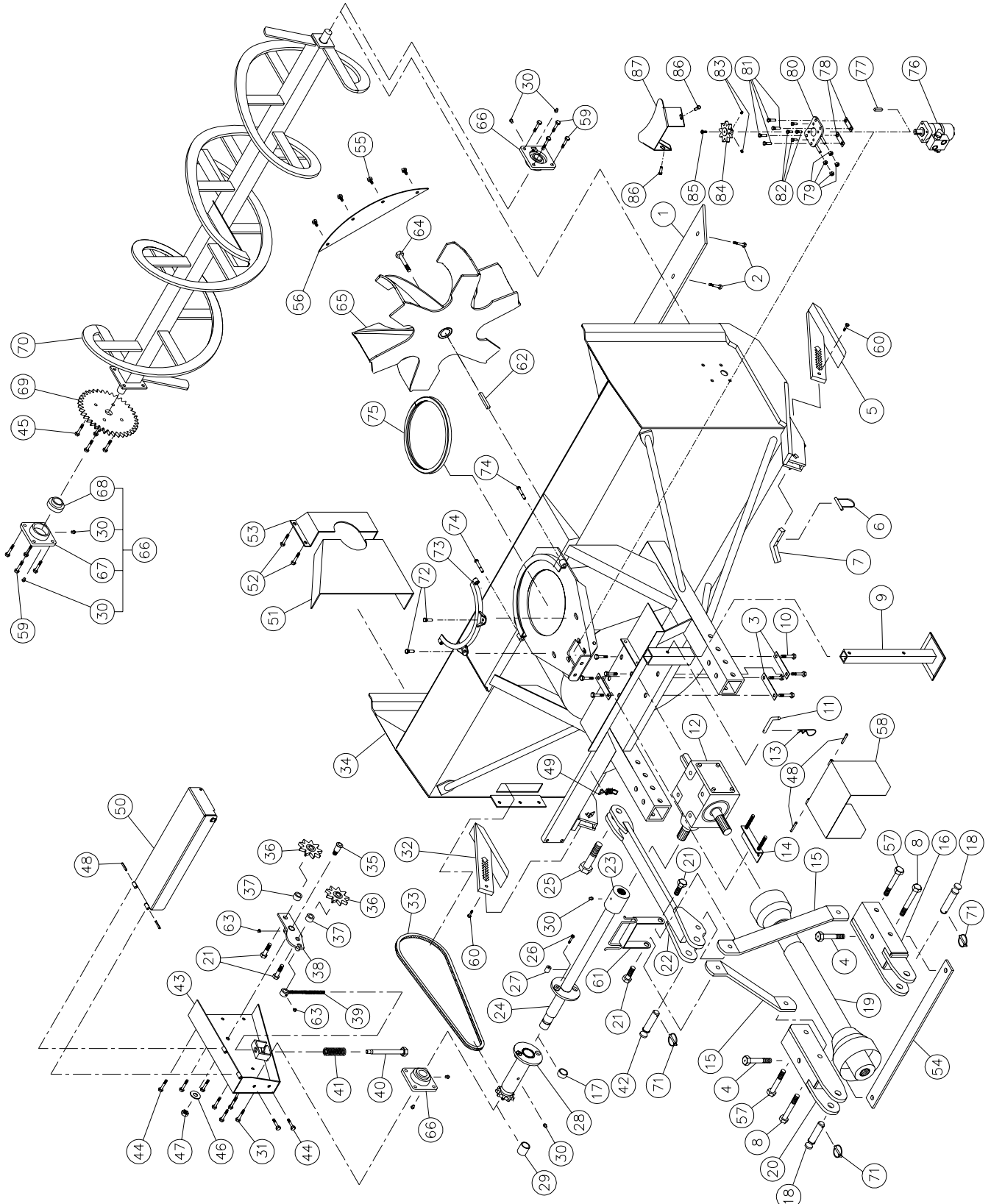

SNOWBLOWER P-98134 (suite)

REF.	PART #	DESCRIPTION	QTY
1	140-00832	Reversible scraper blade 1/2" x 4" x 90 1/2" lg	1
2	319-38325	Plow bolt 7/16" NC x 1 3/4" lg + nut & lock washer	9
3	140-10761	Back plate	3
4	302-46550	Bolt 3/4" NF x 5 1/2" lg + nylon locknut	2
5	110-04531	Skid shoe (right side)	1
6	8112	Lock pin 1/4"	2
7	140-03361	Skid shoes lock	2
8	302-46610	Bolt 3/4" NF x 6 1/2" lg + nylon locknut	2
9	9462	Storage support	1
10	300-44280	Bolt 5/8" NC x 1 1/4" lg + lock washer	8
11	8220	Storage support pin	1
12	9307	Gear box	1
13	Std.	Hitch pin clip 5/32"	1
14	9428	Adjustment plate for gear box + 4 nuts 1/2" NC	1
15	140-05592	3-points side bar	2
16	110-15214	Right lower hitch	1
17	160-06901	Aluminium-bronze bushing 1 3/4" i.d. x 2" o.d. x 1/2" lg	1
18	9269	Pin category 2 (1 1/8" diameter)	2
19	9225	PTO shaft T80	1
20	110-15213	Left lower hitch	1
21	300-46400	Bolt 3/4" NC x 3" lg + nylon locknut	4
22	110-15421	Upper hitch	1
23	6467	Splined adaptor 1 3/4"-20 (welded)	1
24	110-18261	Auger drive shaft 37 3/16" lg overall (including no. 23 and 27)	1
25	300-54460	Bolt 1 1/4" NC x 4" lg + nylon locknut	1
26	300-34340	Bolt 5/16" NC x 2" lg grade 5 + nylon locknut	1
27	150-03911	Bushing 5/16" i.d. x 1" o.d. x 3/4" lg (welded)	2
28	110-18241	Sprocket #80 + shearplate (includes no. 17 & 29)	1
29	160-07311	Aluminium-bronze bushing 1 1/2" i.d. x 1 7/8" o.d. x 1 1/4" lg	1
30	Std.	Grease fitting 1/4"-28 straight	8
31	300-40310	Bolt 1/2" NC x 1 1/2" lg + nylon locknut thin	4
32	110-04521	Skid shoe (left side)	1
33	190-00431	Chain no. 80 x 79" lg (79 links)	1
33	26A80	Connecting link no. 80	1
33	59-80	Offset link no. 80	1
34	120-05801	Frame P-98134	1
35	150-00332	Idler clevis pin	1
36	9287	Idler sprocket #80 (steel)	2
37	160-06511	Spacer 3/4" i.d. x 1 1/4" o.d. x 3/4" lg	2
38	110-01052	Idler	1
39	110-01063	Threaded rod for idler adjustment + nut 7/16" NC	1
40	110-01071	Threaded rtube for idler adjustment	1
41	9688	Compression spring	1
42	150-05961	Pin category 2 (1" diameter) (top link)	1
43	110-10564	Chain guard	1
44	301-38250	Bolt 7/16" NC x 1" lg + nylon locknut	5
45	301-38310	Bolt 7/16" NC x 1 1/2" lg + two-way locknut	4
46	376-44000	Rondelle plate 5/8"	1
47	346-45000	Flat washer 5/8" NC thin	1
48	Std.	Roll pin 5/16" x 2" lg	2
49	8375	Adjustable clamp fastener (welded)	1
50	110-32671	Side shaft guard	1
51	130-53791	Inside guard (welded)	1
52	300-36250	Bolt 3/8" NC x 1" lg + nylon locknut & flat washer	4
53	8925	Inside guard (bolted)	1
54	140-03561	Brace 3/8" x 2 1/2" x 42 1/4" lg	1
55	301-38280	Bolt 7/16" NC x 1 1/4" lg + nylon locknut	4
56	130-05911	Deflector	1

SNOWBLOWER P-98134 (suite)

REF.	PART #	DESCRIPTION	QTY
57	302-46580	Bolt 3/4" NF x 6" lg + nylon locknut	2
58	110-12541	Hinged PTO shroud	1
59	300-40325	Bolt 1/2" NC x 1 3/4" lg + nylon locknut	8
60	300-32310	Bolt 1/4" NC x 1 1/2" lg + nylon locknut	2
61	110-15201	Hoses support	1
62	9285	Key 1/2" x 1/2" x 4" lg	1
63	Std.	Grease fitting 1/4" - 28 90 deg.	2
64	300-44310	Bolt 5/8" NC x 1 1/2" lg (ass. with lock-tite 242) + lock washer	1
65	110-32481	Impeller 34" ø 6 blades	1
66	UCFD208-24	Bearing 1 1/2" + flange + 2 straight grease fitting	3
67	FD208	Flange for 2 grease fitting	3
68	UC208-24	Bearing 1 1/2"	3
69	9281	Sprocket 80A30 T 1 1/2" ø	1
70	110-05171	Auger	1
71	Std.	Lynch oin 1/4" x 1 3/4"	3
72	300-40310	Bolt 1/2" NC x 1 1/2" lg. + nylon locknut & flat washer	2
73	110-01341	Retaining bracket	1
74	300-38400	Bolt 7/16" NC x 3" lg. + nylon locknut	2
75	8149	U-shaped UHMW approx. 14" interior diameter	1
76	MLH 315	"Orbit" hydraulic motor + cushion valve	opt.
77	8369	Key for hydraulic motor	opt.
78	140-09571	Spacer 1/8" x 1" x 3 1/4" lg for hydraulic motor	2
79	336-38000	Nut 7/16" NC	4
80	110-20811	Hydraulic motor support	1
81	300-38310	Bolt 7/16" NC x 1 1/2" lg + nylon locknut & flat washer	4
82	300-36250	Bolt 3/8" NC x 1" lg + lock washer	4
83	323-36160	Hexagonal socket set screw 3/8" NC x 3/8" lg	2
84	110-04182	Sprocket 9 teeth	1
85	300-32220	Bolt 1/4" NC x 3/4" lg + lock washer	1
86	300-38280	Bolt 7/16" NC x 1 1/4" lg + nylon locknut & flat washer	2
87	130-29491	Hydraulic motor guard	1

SNOWBLOWER P-98134TRC

170-04241

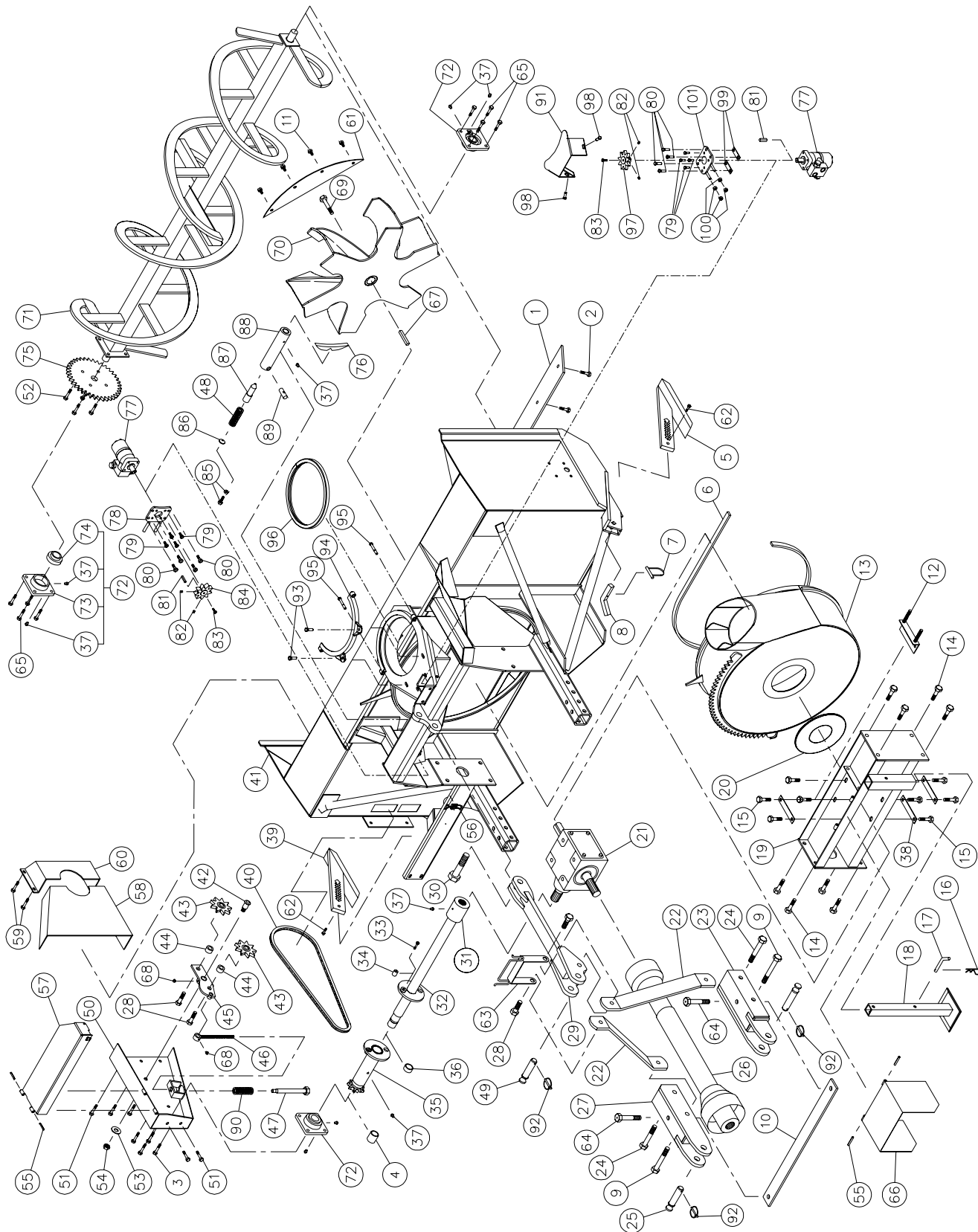

10

SNOWBLOWER P-98134TRC (suite)

REF.	PART #	DESCRIPTION	QTY
1	140-00832	Reversible scraper blade 1/2" x 4" x 90 1/2" lg	1
2	125-00717	Plow bolt 7/16" NC x 1 3/4" lg + nut & lock washer	9
3	301-40310	Bolt 1/2" NC x 1 1/2" lg + nylon locknut mince	4
4	160-07311	Aluminium-bronze bushing 1 1/2" i.d. x 1 7/8" o.d. x 1 1/4" lg	1
5	110-04531	Skid shoe (right side)	1
6	9430	U-shaped UHMW 3/8" x 7/8" x 109 1/4" lg	1
7	8112	Lock pin 1/4"	2
8	140-03361	Skid shoes lock	2
9	302-46610	Bolt 3/4" NF x 6 1/2" lg + nylon locknut	2
10	140-03561	Brace 3/8" x 2 1/2" x 42 1/4" lg	1
11	301-38280	Bolt 7/16" NC x 1 1/4" lg + nylon locknut	4
12	9428	Adjustment plate for gear box + 6 nuts 1/2" NC	1
13	110-31871	Rotary drum 34" ø x 12" depth	1
14	301-46340	Bolt 3/4" NC x 2" lg + nylon locknut	8
15	300-44280	Bolt 5/8" NC x 1 1/4" lg + lock washer	8
16	Std.	Hitch pin clip 5/32"	1
17	8220	Storage support pin	1
18	9462	Storage support	1
19	110-31951	Gear box support	1
20	9432	U-shaped UHMW 3/16" x 8 7/8" i.d. x 12" o.d.	1
21	9307	Gear box	1
22	140-05592	3-points side bar	2
23	110-15214	Right lower hitch	1
24	301-46580	Bolt 3/4" NC x 6" lg + nylon locknut	2
25	9269	Pin category 2 (1 1/8" diameter)	2
26	9225	PTO T80	1
27	110-15213	Left lower hitch	1
28	301-46400	Bolt 3/4" NC x 3" lg + nylon locknut	4
29	110-15531	Upper hitch	1
30	300-54460	Bolt 1 1/4" NC x 4" lg + nylon locknut	1
31	6467	Splined adaptor 1 3/4" - 20 (welded)	1
32	110-18261	Auger drive shaft 37 3/16" lg overall (incl. no. 31 and 34)	1
33	301-34340	Bolt 5/16" NC grade 5 x 2" lg + nylon locknut	1
34	150-03911	Bushing 5/16" i.d. x 1" o.d. x 3/4" lg (welded)	2
35	110-18241	Sprocket #80 + shearplate (including no. 36 & 105)	1
36	160-06901	Aluminium-bronze bushing 1 3/4" d.i. x 2" d.e. x 1/2" lg	1
37	Std.	Grease fitting 1/4"-28 straight	9
38	140-10761	Back plate	3
39	110-04521	Skid shoe (left side)	1
40	190-00431	Chain no. 80 x 79" lg (79 links)	1
40	26A80	Connecting link no. 80	1
40	59-80	Offset link no. 80	1
41	120-05821	Frame P-98134TRC	1
42	150-00332	Idler clevis pin	1
43	9287	Idler sprocket #80	2
44	160-06511	Spacer 3/4" i.d. x 1 1/4" o.d. x 3/4" lg	2
45	110-01052	Idler	1
46	110-01063	Threaded rod for idler adjustment + nut 7/16" NC	1
47	110-01071	Threaded tube for idler adjustment	1
48	9473	Compression spring (black)	1
49	150-05961	Pin category 2 (1" diameter) (top link)	1
50	110-10564	Chain guard	1
51	301-38250	Bolt 7/16" NC x 1" lg + nylon locknut	5
52	301-38310	Bolt 7/16" NC x 1 1/2" lg + two-way locknut	4
53	376-40000	Flat washer 5/8"	1
54	346-45000	Nylon locknut 5/8" NC thin	1

SNOWBLOWER P-98134TRC (suite)

REF.	PART #	DESCRIPTION	QTY
55	Std.	Roll pin 5/16" x 2" lg	4
56	8374	Adjustable clamp fastener (welded)	1
57	110-32131	Side shaft guard for P-98134TRC	1
58	130-53791	GInside guard (bolted)	1
59	300-36250	Bolt 3/8" NC x 1" lg + nylon locknut & flat washer	4
60	8925	Garde intérieur (bolted)	1
61	130-05911	Deflector	1
62	300-32310	Bolt 1/4" x 1 1/2" lg + nylon locknut	2
63	110-15201	Hoses support	1
64	302-46520	Bolt 3/4" NF x 5 1/2" lg + nylon locknut	2
65	300-40325	Bolt 1/2" NC x 1 3/4" lg + nylon locknut	8
66	110-12541	Hinged PTO shroud	1
67	9285	Key 1/2" x 1/2" x 4" lg	1
68	Std.	Grease fitting 1/4"-28 90 deg	2
69	300-44310	Bolt 5/8" NC x 1 1/2" lg (ass. with lock-tite 242) + lock washer	1
70	110-32481	Impeller 34" ø 6 blades	1
71	110-05171	Auger P-920-98	1
72	UCFD208-24	Bearing 1 1/2" + flange 2 straight grease fitting	3
73	FD208	Flange for 2 grease fitting	3
74	UC208-24	Bearing 1 1/2"	3
75	9281	Sprocket 80A30 T 1 1/2" ø	1
76	130-08441	Stop block for drum lock (welded on drum)	1
77	MLH-315	Hydraulic motor "Orbit" + cushion valve	opt.
78	110-18441	"Orbit" support motor + 4 nuts 7/16" NC	1
79	300-36250	Bolt 3/8" x 1" lg + lock washer	4
80	300-38310	Bolt 7/16" NC x 1 1/2" lg + nylon locknut & flat washer	4
81	8369	Key for "Orbit" motor	opt.
82	323-36160	Hexagonal socket set screw 3/8" NC x 3/8" lg	4
83	300-32220	Bolt 1/4" NC x 3/4" lg + lock washer	2
84	110-04721	Sprocket 9 teeth	1
85	300-38330	Bolt 7/16" NC x 1 3/4" lg (full length thread) + lock nut	1
86	130-08471	Washer	1
87	150-01542	Latch pin - drum lock	1
88	160-03952	Body - drum lock (welded on frame)	1
89	150-02561	Pin	1
90	9688	Compression spring	1
91	130-29491	Hydraulic motor guard	1
92	Std.	Lynch pin 1/4" x 1 3/4"	3
93	300-40310	Bolt 1/2" NC x 1 1/2" lg + nylon locknut & flat washer	2
94	110-01341	Retaining bracket	1
95	300-38400	Bolt 7/16" NC x 3" lg + nylon locknut	2
96	8149	U-shaped UHMW approx. 14" interior diameter	1
97	110-04182	Sprocket 9 teeth	1
98	300-38280	Bolt 7/16" NC x 1 1/4" lg + nylon locknut & flat washer	2
99	140-09571	Spacer 1/8" x 1" x 3 1/4" lg for hydraulic motor	2
100	336-38000	Nut 7/16" NC	8
101	110-20811	Hydraulic motor support	1

CHUTE CST-7486

170-03271

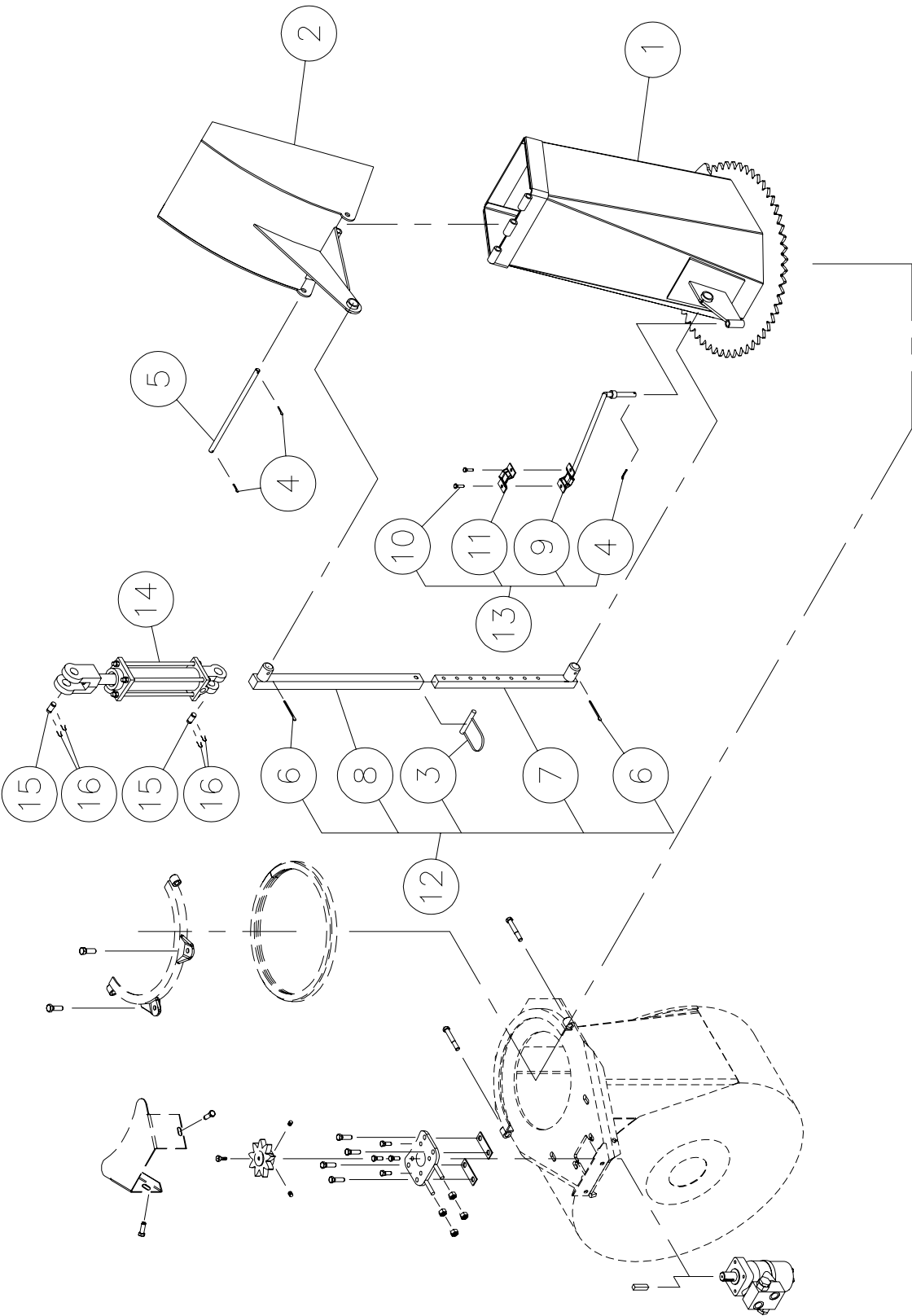

CHUTE CST-7486

REF.	PART #	DESCRIPTION	QTY
1	110-04401	Chute base	1
2	8370	Chute deflector	1
3	8112	Lock pin 1/4" (1)	opt.
4	Std.	Cotter pin 1/8" x 1" lg	3
5	8210	Chute deflector pin	1
6	Std.	Cotter pin 5/32" x 2" lg (2)	opt.
7	8145	Chute adjusting rod (1)	opt.
8	8146	Chute adjusting tube (1)	opt.
9	110-01112	Mounting support plate	1
10	300-32250	Bolt 1/4" NC x 1" lg. + nylon locknut	2
11	140-13071	Hoses mounting plate	1
12	T-74104	Manual telescopic tube	opt.
13	TSB-74104	Hose support for deflector cylinder	opt.
14	25TR08	Cylinder	opt.
15	6004	Clevis pin 1" x 3 1/8" lg (2)	opt.
16	Std.	Hairpin cotter 7/8" (4)	opt.

SEMI-INDUSTRIAL CHUTE PSIG-7486

170-03393

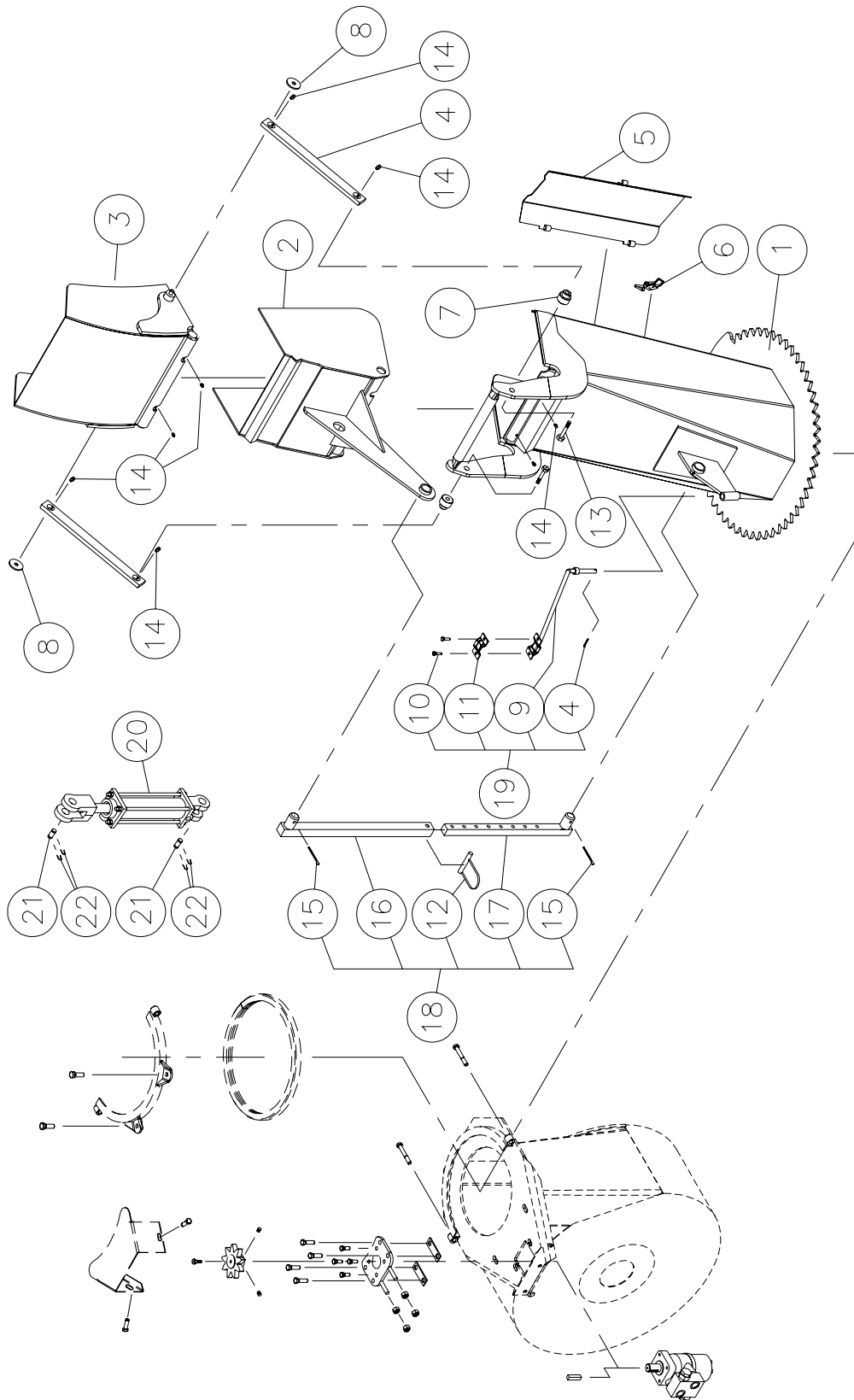

SEMI-INDUSTRIAL CHUTE PSIG-7486

REF.	PART #	DESCRIPTION	QTY
1	110-22503	Chute base	1
2	110-22521	Lower chute deflector	1
3	110-22511	Upper chute deflector	1
4	140-14041	Connecting rod	2
5	110-22893	Access panel	1
6	8376	Adjustable clamp fastener (welded)	1
7	150-05311	Spacer for connecting rod	2
8	378-36500	Washer	2
9	110-01112	Hoses support	1
10	300-32250	Bolt 1/4" NC x 1" lg + nylon locknut	2
11	140-13071	Hose hold down	1
12	8112	Lock pin 1/4" (1)	opt.
13	300-40380	Bolt 1/2" NC x 2 3/4" lg + nylon lock nut & washer	2
14	Std.	Grease fitting 1/4"-28 straight	8
15	Std.	Cotter pin 5/32" x 2" lg (2)	opt.
16	8146	Chute adjusting tube (1)	opt.
17	8145	Chute adjusting rod (1)	opt.
18	T-74104	Manual telescopic tube	opt.
19	TSB-74104	Hose support for deflector cylinder	opt.
20	25TR08	Cylinder	opt.
21	6004	Clevis pin 1" x 3 1/8" lg (2)	opt.
22	Std.	Hairpin cotter 7/8" (4)	opt.

INDUSTRIAL CHUTE PCG-7486

170-03413

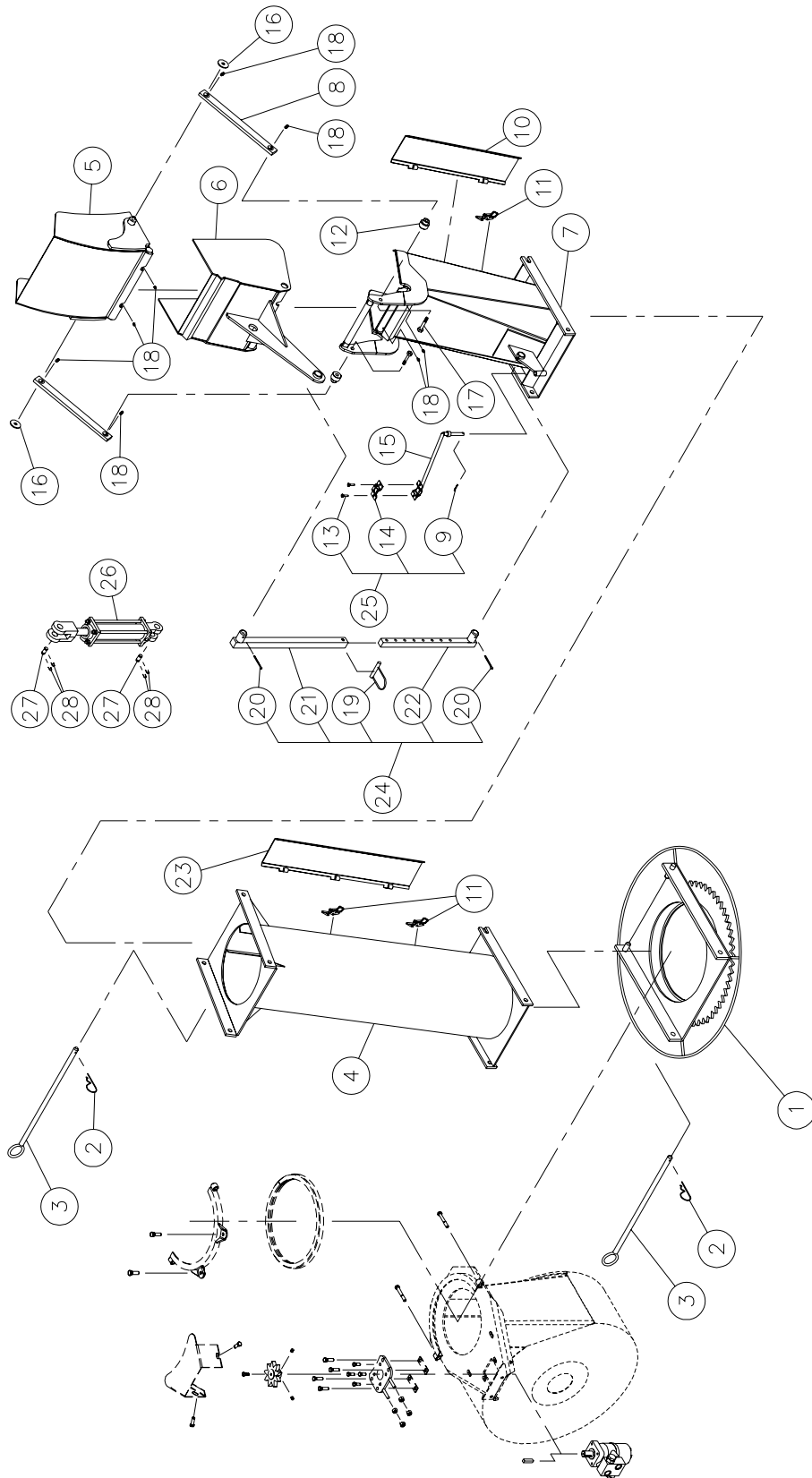

INDUSTRIAL CHUTE PCG-7486

REF.	PART #	DESCRIPTION	QTY
1	110-04441	Chute adaptor with quick attach	1
2	Std.	Hitch pin clip 5/32"	2
3	8200	Pin for quick attach (adaptor & extension)	2
4	110-22961	Extension 48" PRP-7486	opt.
4	110-23051	Extension 24" PRP-7486-2	opt.
5	110-22511	Upper deflector	1
6	110-22521	Lower deflector	1
7	110-22563	Chute base	1
8	140-14041	Connection rod	2
9	Std.	Cotter pin 1/8" x 1" lg	1
10	110-22893	Access panel	1
11	8376	Adjustable clamp fastener (welded)	1
12	150-05311	Spacer for connecting rod	2
13	300-32250	Bolt 1/4" NC x 1" lg. + nylon locknut	2
14	140-13071	Hoses mounting plate	1
15	110-01112	Mounting support plate	1
16	378-36500	Washer	2
17	300-40380	Bolt 1/2" NC x 2 3/4" lg + nylon locknut & washer	2
18	Std.	Grease fitting 1/4"-28 straight	8
19	8112	Lock pin 1/4" (1)	opt.
20	Std.	Cotter pin 5/32" X 2" lg (2)	opt.
21	8146	Chute adjusting tube (1)	opt.
22	8145	Chute adjusting rod (1)	opt.
23	110-23022	Access panel for extension PRP-7486	opt.
23	110-23062	Access panel for extension PRP-7486-2	opt.
24	T-74104	Manual telescopic tube	opt.
25	TSB-74104	Hose support for deflector cylinder	opt.
26	25TR08	Cylinder	opt.
27	6004	Clevis pin 1" x 3 1/8" lg (2)	opt.
28	Std.	Hairpin cotter 7/8" (4)	opt.

OPTIONS

170-02841R1

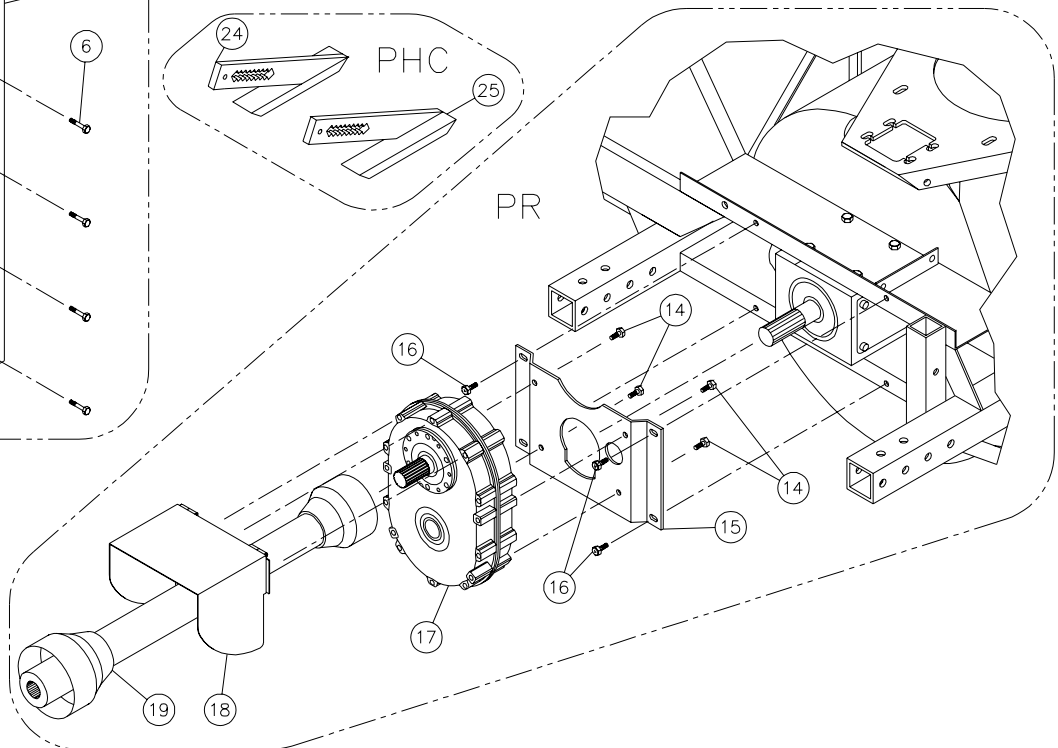
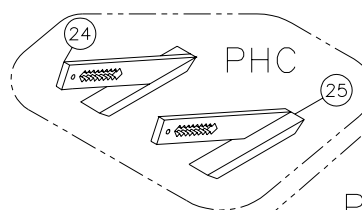
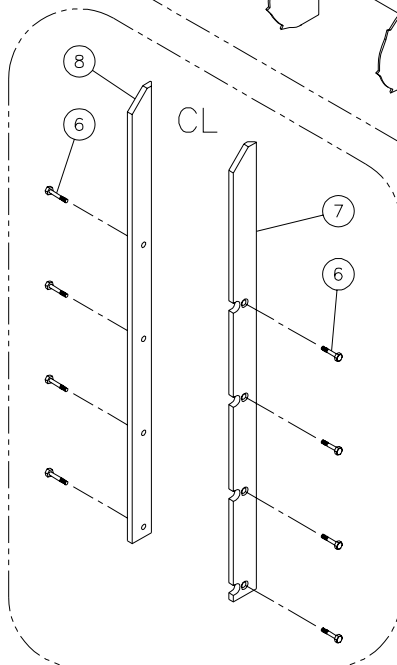
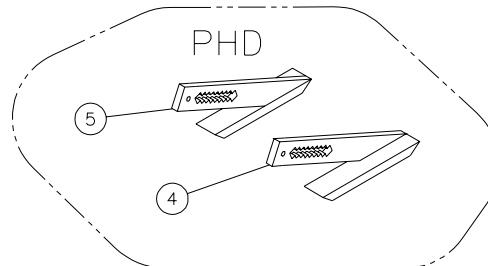
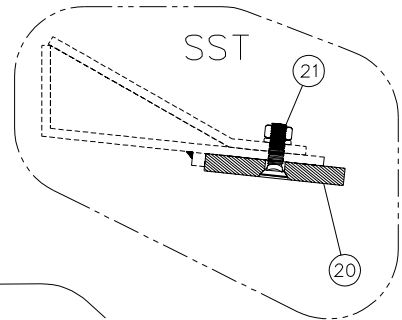
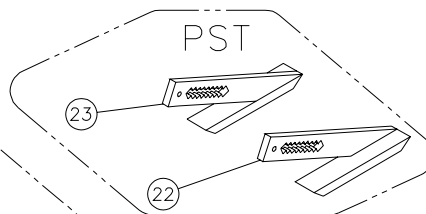
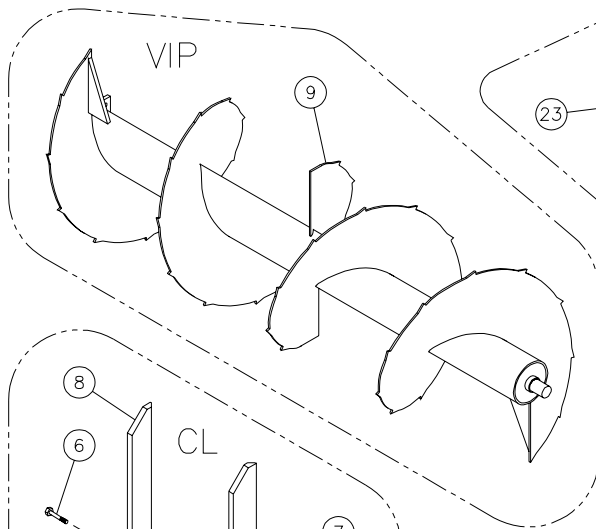
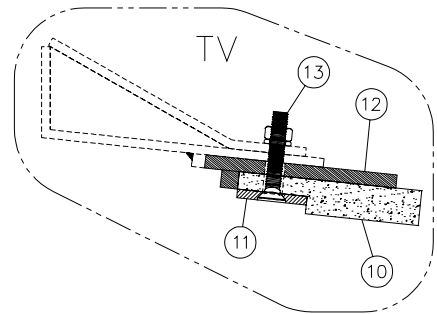
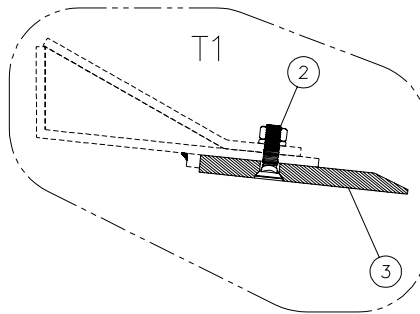
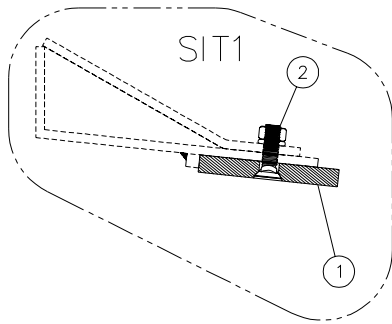

OPTIONS

REF.	PART #	DESCRIPTION	P-920	P-920 TRC	P-920-98	P-920TRC-98	P-98134	P-98134TRC
1	140-04081	Scraper blade (hard. steel, not sharpened, reversible) 1/2" x 4" x 84 1/2" .	1	1	-	-	-	-
1	140-04091	Scraper blade (hard. steel, not sharpened, reversible) 1/2" x 4" x 90 1/2" .	-	-	1	1	1	1
2	319-38325	Plow bolt 7/16" NC x 1 3/4" lg + nut & lock washer	9	9	9	9	9	9
3	140-04141	Scraper blade (hardened steel, sharpened, not reversible) 1/2" x 6" x 84 1/2" .	1	1	-	-	-	-
3	140-04151	Scraper blade (hardened steel, sharpened, not reversible) 1/2" x 6" x 90 1/2" .	-	-	1	1	1	1
4	110-05511	Carbon steel skid shoe (right side)	1	1	1	1	1	1
5	110-04811	Carbon steel skid shoe (left side)	1	1	1	1	1	1
6	319-38310	Plow bolt 7/16" NC x 1 1/2" lg + nut & lock washer	8	8	8	8	8	8
7	130-08321	Lateral blade (right side)	1	1	1	1	1	1
8	130-08322	Lateral blade (left side)	1	1	1	1	1	1
9	9425	Full flight spiked auger 23" dia. x 89 5/8"	1	1	-	-	-	-
9	110-21131	Full flight spiked auger 23" dia. x 95 5/8" hors tout	-	-	1	1	1	1
10	190-01331	Scraper blade, TIVAR not reversible 1" x 5 1/4" x 84 1/2"	1	1	-	-	-	-
10	190-01321	Scraper blade, TIVAR not reversible 1" x 5 1/4" x 90 1/2"	-	-	1	1	1	1
11	140-03991	TIVAR blade bolting plate 1/4" x 2" x 84 1/2"	1	1	-	-	-	-
11	140-03981	TIVAR blade bolting plate 1/4" x 2" x 90 1/2"	-	-	1	1	1	1
12	110-10391	TIVAR blade holder 3/8" x 5 1/2" x 84 1/2"	1	1	-	-	-	-
12	110-10381	TIVAR blade holder 3/8" x 5 1/2" x 90 1/2"	-	-	1	1	1	1
13	319-38370	Plow bolt 7/16" NC x 2 1/2" lg + nut & lock washer	9	9	9	9	9	9
14	Std.	Bolt 1/2" NC x 1 1/4" lg + lock washer	4	4	4	4	4	4
15	130-19521	Mounting plate for speed reducer 1000 to 540	1	1	1	1	1	1
16	Std.	Bolt 1/2" NC x 1 1/2" lg + nylon locknut & flat washer (x)	4	4	4	4	4	4
17	9575	Speed reducer 1000@540 "triple chain"	1	1	1	1	1	1
18	110-12961	Hinged PTO shroud for speed reducer 1000@540	1	1	1	1	1	1
19	9569	P.T.O. T80, QD 1 3/8" -21 splines, SBI 1 3/4"-20	1	1	1	1	1	1
19	9569-1	P.T.O. T80, QD 1 3/4"-20 splines, SBI 1 3/4"-20	1	1	1	1	1	1
19	9475-1	P.T.O. T90, QD 1 3/8"-21 splines, SBI 1 3/4"-20	1	1	1	1	1	1
19	9475-2	P.T.O. T90, QD 1 3/4"-20 splines, SBI 1 3/4"-20	1	1	1	1	1	1
20	140-15041	Scraper blade (stainless steel, not sharpened, reversible) 1/2" x 4" x 84 1/2" .	1	1	-	-	-	-
20	140-15051	Scraper blade (stainless steel, not sharpened, reversible) 1/2" x 4" x 90 1/2" .	-	-	1	1	1	1
21	333-40340	Hexagonal socket set screw 1/2" NC x 2" lg (inox.) + nut & lock washer	opt.	opt.	opt.	opt.	opt.	opt.
21	319-38325	Plow bolt 7/16" NC x 1 3/4" lg + nut & lock washer	9	9	9	9	9	9
22	110-24831	Stainless steel skid shoe (right side)	1	1	1	1	1	1
23	110-24832	Stainless steel skid shoe (left side)	1	1	1	1	1	1
24	110-32871	Skid shoe with carbide sole (left side)	1	1	1	1	1	1
25	110-32872	Skid shoe with carbide sole (right side)	1	1	1	1	1	1

P.T.O. SHAFT # 9225-EG & 9569 (T80)

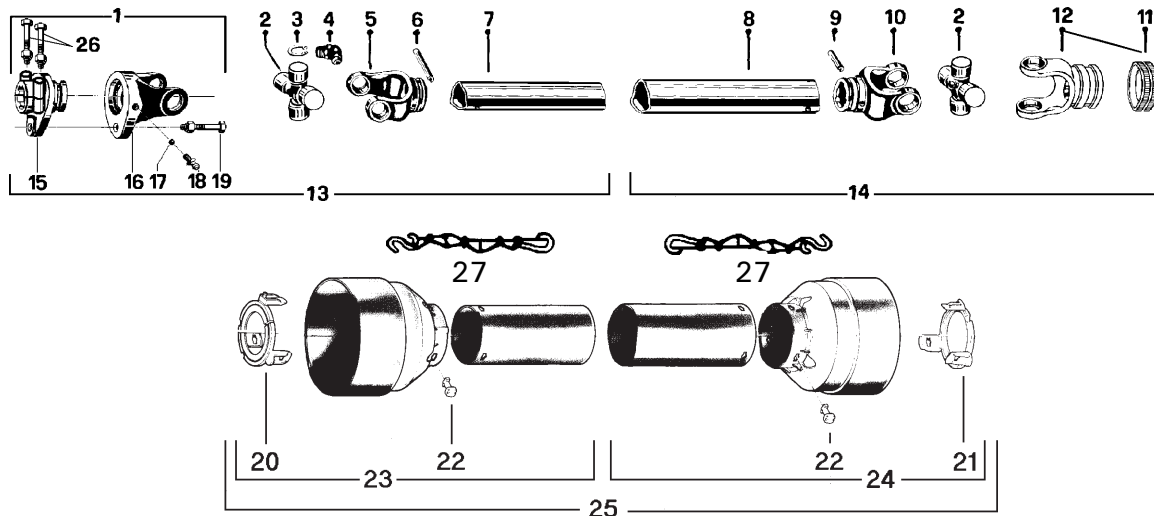

REF.	PART #	DESCRIPTION	QTY	
			9225-EG	9569
or [1	9570	Safety shear yoke M10 (2 bolts) 1 3/4" - 20 splines	-	1
1	9453	Safety shear yoke M12 (2 bolts) 1 3/4" - 20 splines	1	1
2	9208	U-joint + 4 retaining rings + 1 grease fitting	2	2
3	9454	Retaining ring	8	8
4	8110	Grease fitting	2	2
5	9214	Yoke for inner tube	1	1
6	8075	Stopper for inner tube	1	1
7	9212	Inner tube	1	1
8	9211	Outer tube	1	1
9	9210-E	Stopper for outer tube	1	1
10	9209	Yoke for outer tube	1	1
11	8363	Collar kit	1	1
11	8364	Collar kit	-	opt.
12	9455	Yoke with hole 1 3/8"-6 splines + yoke stopper	1	-
12	9463	Yoke with hole 1 3/8"-21 splines + yoke stopper	-	1
12	9224	Yoke with hole 1 3/4"-20 splines + yoke stopper	-	opt.
13	9456	P.T.O. section, SBI 1 3/4"-20, inner part, without protector	1	1
14	9457	P.T.O. section, QD 1 3/8"-6, outer part, without protector	1	-
14	9457-2	P.T.O. section, QD 1 3/8"-21, outer part, without protector	-	1
or [15	9458	Adaptor 1 3/4"-20 splines (2 bolts) (hole 12 mm)	1	1
15	9571	Adaptor 1 3/4"-20 splines (2 bolts) (hole 10 mm)	-	1
or [16	9204	Yoke and shearplate (hole 12 mm)	1	1
16	9572	Yoke and shearplate (hole 10 mm)	-	1
17	9205	Ball	17	17
18	8071	Grease fitting	1	1
19	9207	Safety shear bolt M12 x 65 mm	1	-
or [19	9207-375	Safety shear bolt M12 x 65 mm diam. 3/8"	-	1
19	8218	Safety shear bolt M10 x 60 mm	-	1
20	9459	Bearing ring for inner guard tube	1	1
21	9460	Bearing ring for outer guard tube	1	1
22	8109	Stopper	6	6
23	9221	Inner shield	1	1
24	9220	Outer shield	1	1
25	9222	Complete shield	1	1
26	9461	Bolt M12 x 90mm + lock nut	2	2
27	8308	Safety chain	2	2

P.T.O. SHAFT # 9475, 9475-1 & 9475-2 (T90)

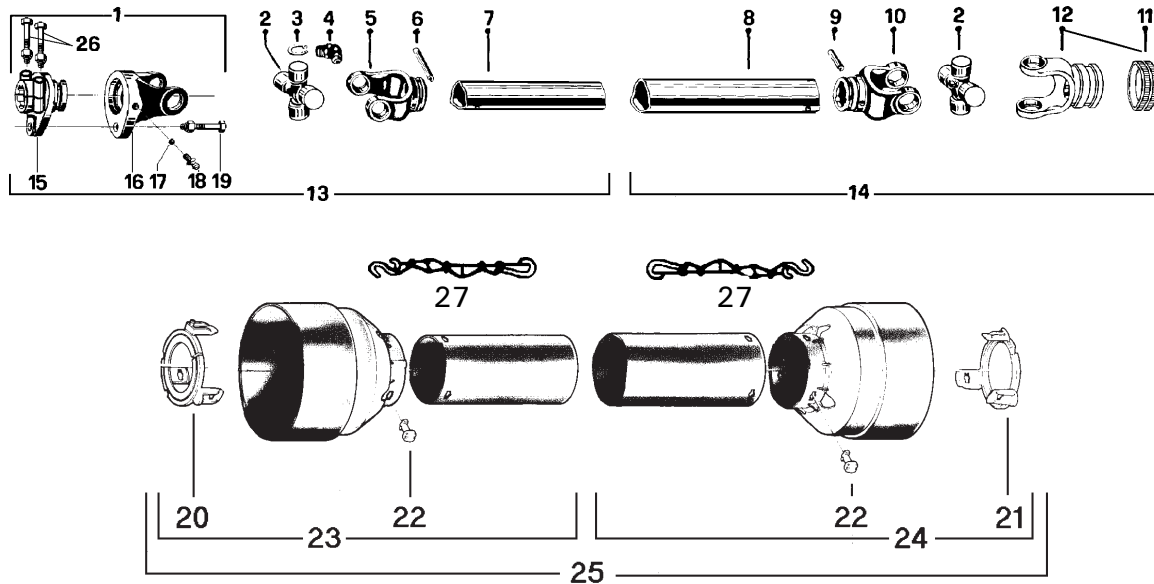

REF.	PART #	DESCRIPTION	QTY		
			9475	9475-1	9475-2
1	9476	Safety shear yoke (2 bolts) 1 3/4" - 20 splines	1	1	1
2	9477	U-joint + 4 retaining rings + 1 grease fitting	2	2	2
3	9478	Retaining ring	8	8	8
4	8110	Grease fitting	2	2	2
5	9479	Yoke for inner tube	1	1	1
6	9210	Stopper for tube	1	1	1
7	9212	Inner tube	1	1	1
8	9211	Outer tube	1	1	1
9	9210	Stopper for tube	1	1	1
10	9480	Yoke for outer tube	1	1	1
11	8363	Collar kit	1	1	-
11	8364	Collar kit	-	-	1
12	9481	Yoke with hole 1 3/8"-6 splines + yoke stopper	1	-	-
12	9482	Yoke with hole 1 3/8"-21 splines + yoke stopper	-	1	-
12	9483	Yoke with hole 1 3/4"-20 splines + yoke stopper	-	-	1
13	9484	P.T.O. section, SBI 1 3/4"-20, inner part, without protector	1	1	1
14	9485	P.T.O. section, QD 1 3/8"-6, outer part, without protector	1	-	-
14	9485-1	P.T.O. section, QD 1 3/8"-21, outer part, without protector	-	1	-
14	9485-2	P.T.O. section, QD 1 3/4"-20, outer part, without protector	-	-	1
15	9486	Adaptor 1 3/4"-20 splines (2 bolts)	1	1	1
16	9487	Yoke and shearplate	1	1	1
17	9205	Ball	24	24	24
18	8071	Grease fitting	1	1	1
19	9207	Safety shear bolt M12 x 65mm	1	-	-
19	9207-375	Safety shear bolt M12 x 65mm diam 3/8"	-	1	1
20	9459	Bearing ring for inner guard tube	1	1	1
21	9460	Bearing ring for outer guard tube	1	1	1
22	8109	Stopper	6	6	6
23	9221	Inner shield	1	1	1
24	9220	Outer shield	1	1	1
25	9222	Complete shield	1	1	1
26	8222	Bolt M12 x 70mm + lock nut	2	2	2
27	8308	Safety chain	2	2	2

GEAR BOX # 9307 (T279)

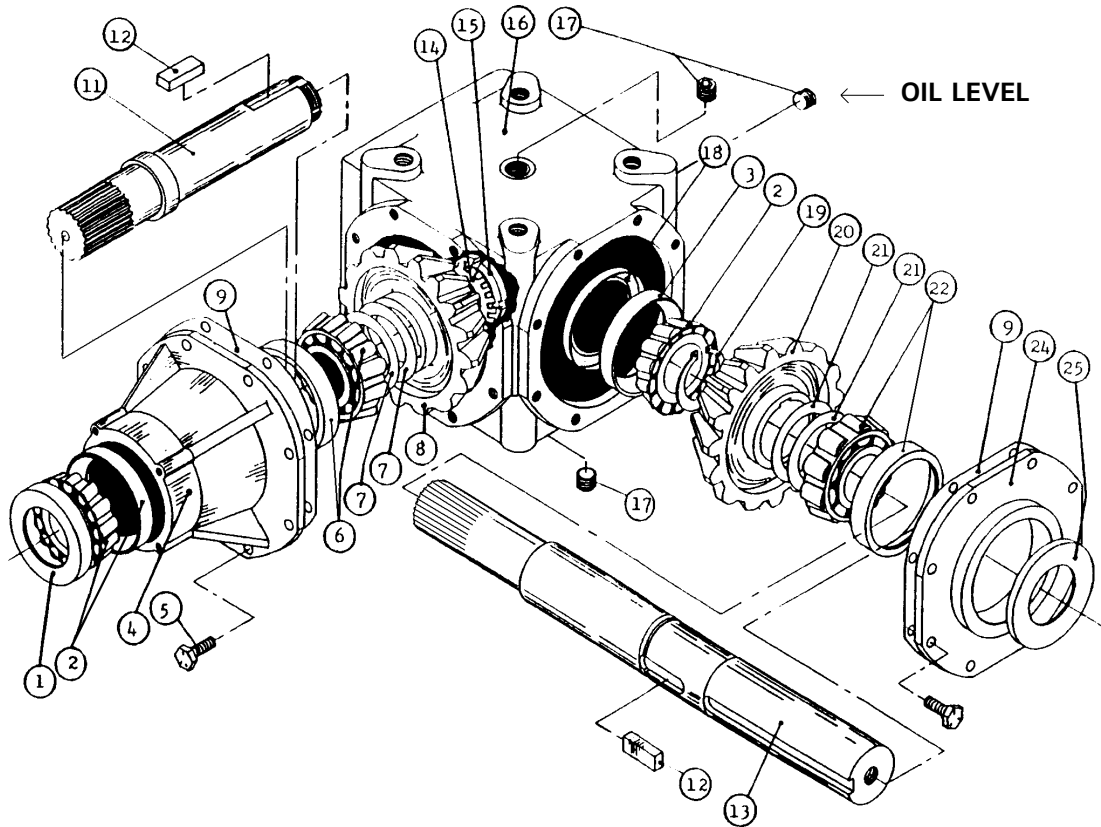

REF.	PART #	DESCRIPTION	QTY
1	6314	Oil seal 52 x 85 x 10	1
2	30209-A	Bearing: cone & cup	2
4	6318	Extension	1
5	6319	Bolt M10 x 22	16
6	32209-A	Bearing: cone & cup	1
7	6321	Shim	2
8	6322	Gear Z21	1
9	- - -	Use silicone caulking	-
11	6325	Side shaft Z20 (1 3/4" - 20 splines)	1
12	6326	Key B14 x 9 x 40	2
13	9345	Impeller shaft (2" & 1 3/4" - 20 splines)	1
14	6328	Spring washer	1
15	6329	Lock nut M40 x 1.5 H9	1
16	6330	Casing	1
17	6331	Plug 3/8" gas	3
18	6332	Dust excluder 45 x 72 x 8	1
19	6333	External circlip 50 UNI7435	1
20	6334	Gear Z21	1
21	6335	Shim	2
22	30210-A	Bearing: cone & cup	1
24	6338	Cover	1
25	6339	Oil seal 50 x 72 x 8	1

REDUCTION GEAR BOX # 9575

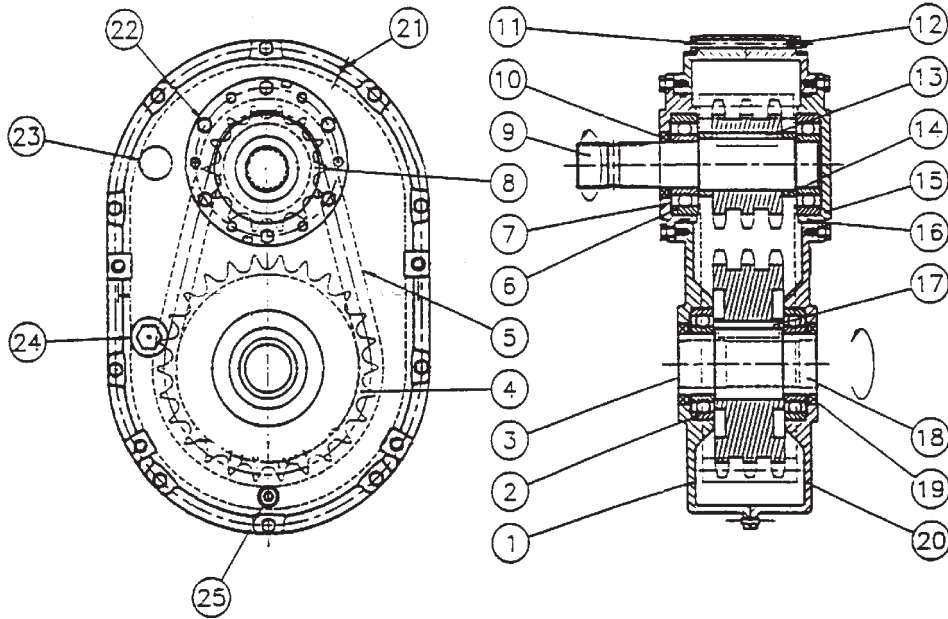

REF.	PART #	DESCRIPTION	QTY
1	9546	Casing with plug	1
2	6212-2RS	Bearing 6212	2
3	9547	Seal cover (47 x 7)	1
4	9548	Sprocket 80-3A26	1
5	9549-RENOLD	Chain 80-3 x 36" lg (Renold)	1
5	9549	Chain 80-3 x 36" lg	opt.
6	6309-2RS	Bearing 6309	2
7	9550	Input cover with hole	1
8	9551	Sprocket 80-3A14	1
9	9552	Input shaft 1 3/4"-20 splines	1
10	9553	Oil seal (45x65x8) TC double lips	1
11	300-34490	Bolt 5/16" NC x 4 1/2" lg	10
12	336-34000	Nut 5/16" NC	10
13	9554	Square key 1/2" x 2 1/2"	1
14	9555	Spacer (2 - 2 3/8 - 0.568)	2
15	9556	Input cover w/o hole	1
16	9557	O-ring AS-248	2
17	9558	Square key 5/8" x 2 1/2"	1
18	9559	Output shaft 1 3/4"-20 splines	1
19	9560	Oil seal (60 x80x10) TC double lips	2
20	9561	Casing w/o plug	1
21	9562	Slotted spring pin 3/16" x 3/4"	2
22	300-30220	Bolt 3/16" NC x 3/4" lg	12
23	9563	Air vent 1/2" NPT	1
24	9564	Oil level sight glass 3/4" NPT	1
25	9565	Drain plug 1/2" NPT	1

10

CYLINDER 25TR08

15050

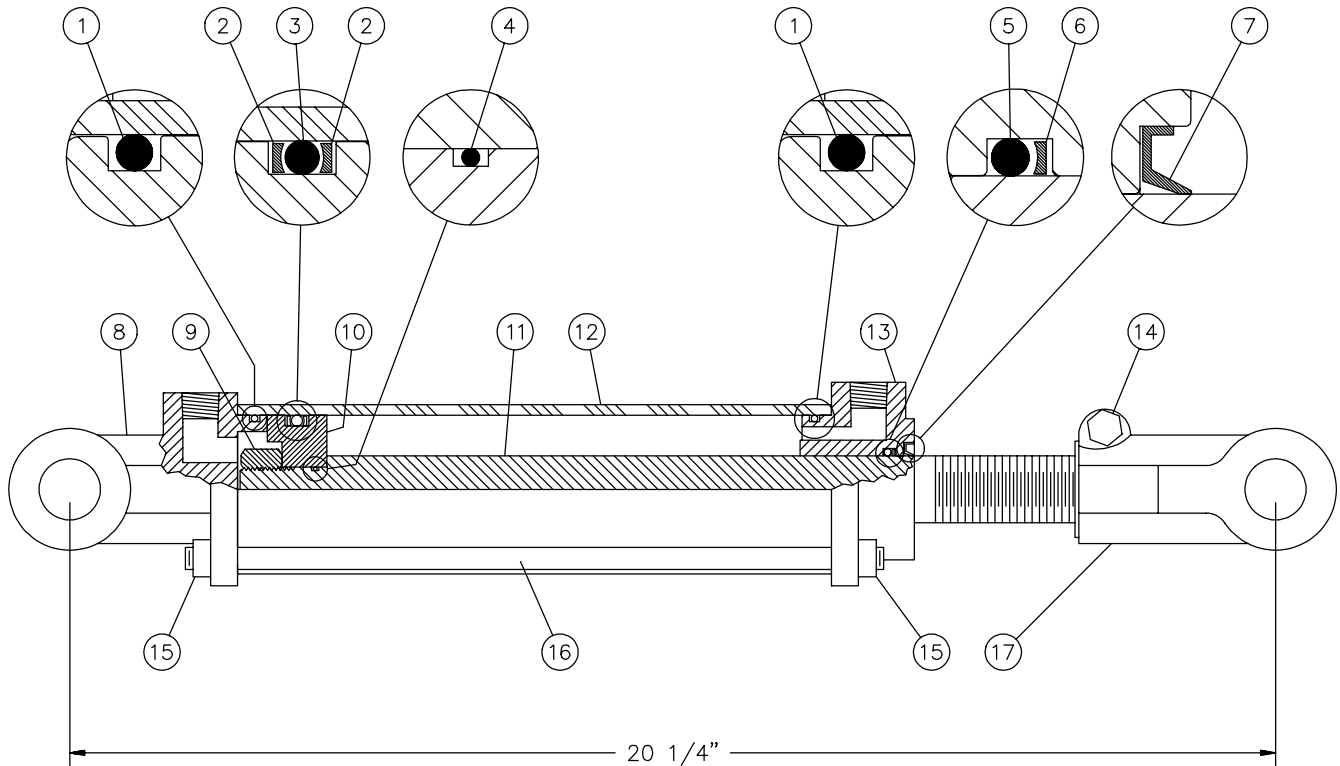

REF.	PART #	DESCRIPTION	QTY
1	See #RK25TR	O-ring 1/8" x 2 1/4" x 2 1/2"	2
2	See #RK25TR	Back-up 2 1/2" o.d. x 3/16 ø	2
3	See #RK25TR	O-ring 3/16" x 2 1/8" x 2 1/2"	1
4	See #RK25TR	O-ring 1/16" x 5/8" x 3/4"	1
5	See #RK25TR	O-ring 1/8" x 1 1/8" x 1 3/8"	1
6	See #RK25TR	Back-up 1 3/8" o.d. x 1/8" ø	1
7	See #RK25TR	Wiper 1 1/8" i.d. x 1 5/8" o.d.	1
8	492401	Yoke (for 2 1/2" tube)	1
9	338-46000	Nut 3/4" NF	1
10	4924-31	Piston 2 1/2" ø	1
11	492028	Piston rod 1 1/8"	1
12	491668	Cylinder body 2 1/2" ø	1
13	492421	Head (for 2 1/2" tube)	1
14	300-36355	Bolt 3/8" NC x 2 1/4" + nut	1
15	336-36000	Nut 3/8" NC	8
16	Std.	Threaded rod 3/8" NC x 12" lg	4
17	458599	Yoke (for 1 1/8" rod)	1
NI*	8183	Pin 1" ø + cotter pin	2
NI*	RK25TR	Repair kit for cylinder 2 1/2" (includes # 1, 2, 3, 4, 5, 6, & 7)	1

*NI = NOT ILLUSTRATED

HYDRAULIC MOTOR # MLH-250 & MLH-315

CUSHION VALVE H110

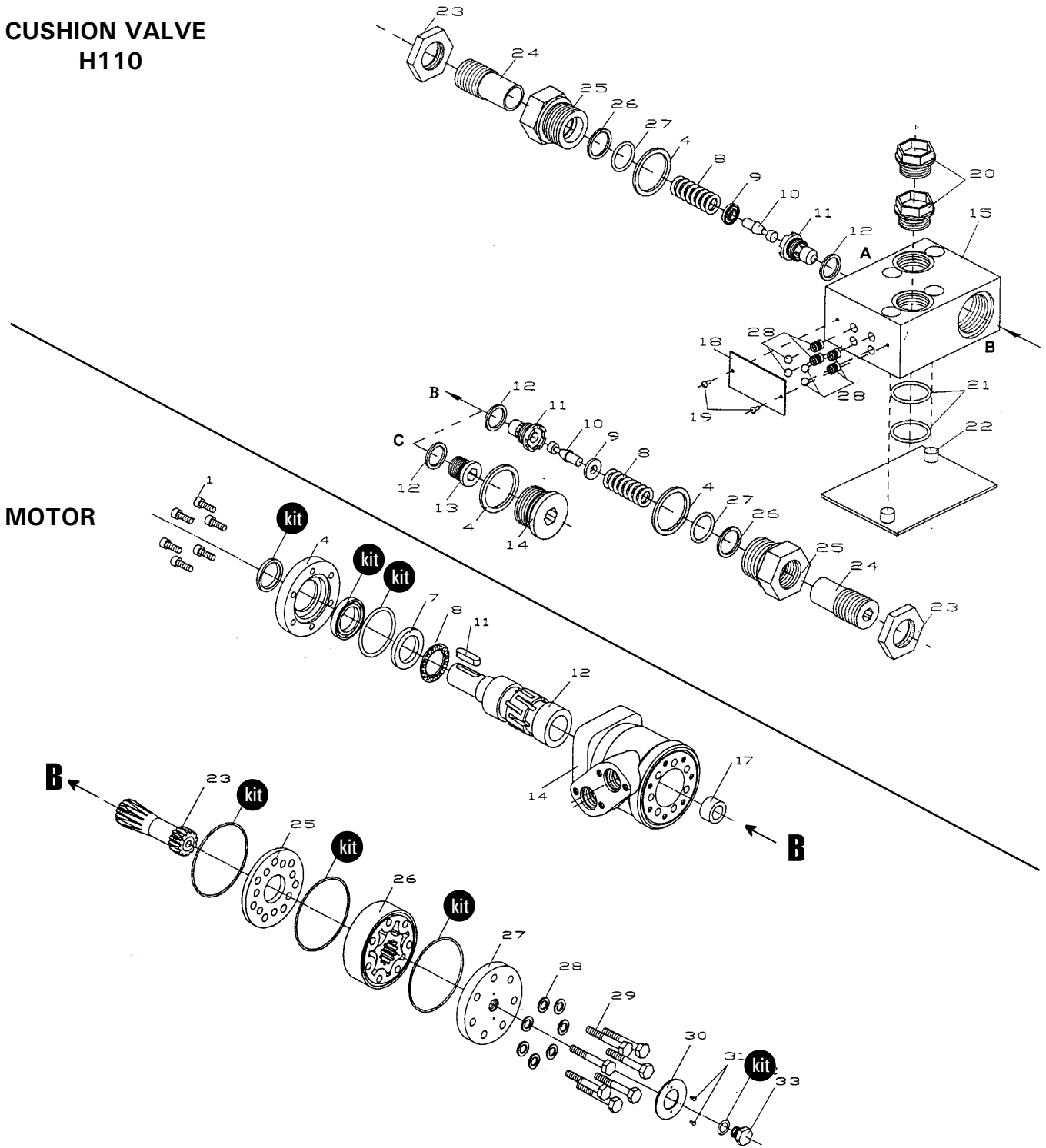







10





REF.	PART #	DESCRIPTION	QTY
kit	8368	Set of seals.....	1
11	8369	Key for "Orbit" motor.....	1

TORQUE CHART

TORQUE SPECIFICATION TABLE

Thread UNC and UNF		Grade 2 				Grade 5   				Grade 8*   			
Bolt size		Torque				Torque				Torque			
Inches	mm	Pound feet min.	max.	Newton meters min.	max.	Pound feet min.	max.	Newton meters min.	max.	Pound feet min.	max.	Newton meters min.	max.
1/4	6.35	5	6	6.8	8.13	9	11	12.2	14.9	12	15	16.3	30.3
5/16	7.94	10	12	13.6	16.3	17	20.5	23.1	27.8	24	29	32.5	39.3
3/8	9.53	20	23	27.1	31.2	35	42	47.5	57.0	45	54	61.0	73.2
7/16	11.11	30	35	40.7	47.4	54	64	73.2	86.8	70	84	94.9	113.9
1/2	12.70	45	52	61.0	70.5	80	96	108.5	130.2	110	132	149.2	179.0
9/16	14.29	65	75	88.1	101.6	110	132	149.2	179.0	160	192	217.0	260.4
5/8	15.88	95	105	128.7	142.3	150	180	203.4	244.1	220	264	298.3	358.0
3/4	19.05	150	185	203.3	250.7	270	324	366.1	439.3	380	456	515.3	618.3
7/8	22.23	160	200	216.8	271.0	400	480	542.4	650.9	600	720	813.6	976.3
1	25.40	250	300	338.8	406.5	580	696	786.5	943.8	900	1080	1220.4	1464.5
1 1/8	25.58	-	-	-	-	800	880	1084.8	1193.3	1280	1440	1735.7	1952.6
1 1/4	31.75	-	-	-	-	1120	1240	1518.7	1681.4	1820	2000	2467.9	2712.0
1 3/8	34.93	-	-	-	-	1460	1680	1979.8	2278.1	2380	2720	3227.3	3688.3
1 1/2	38.10	-	-	-	-	1940	2200	2630.6	2983.2	3160	3560	4285.0	4827.4

* Thick nuts must be used with grade 8 bolts.

Size of screw	Thread	Pitch (mm)	Grade 4T  				Grade 7T 				Grade 8T  			
			Torque				Torque				Torque			
			Pound feet min.	max.	Newton meters min.	max.	Pound feet min.	max.	Newton meters min.	max.	Pound feet min.	max.	Newton meters min.	max.
M6	UNC	1.00	3.6	5.8	4.9	7.9	5.8	9.4	7.9	12.7	7.2	10	9.8	13.6
M8	UNC	1.25	7.2	14	9.8	19	17	22	23	29.8	20	26	27.1	35.2
M10	UNC	1.5	20	25	27.1	33.9	34	40	46.1	54.2	38	46	51.5	62.3
M12	UNC	1.75	28	34	37.9	46.1	51	59	69.1	79.9	57	66	77.2	89.4
M14	UNC	2.0	49	56	66.4	75.9	81	93	109.8	126	96	109	130.1	147.7
M16	UNC	2.0	67	77	90.8	104.3	116	130	157.2	176.2	129	145	174.8	196.5
M18	UNC	2.0	88	100	119.2	136	150	168	203.3	227.6	175	194	237.1	262.9
M20	UNC	2.5	108	130	146.3	176.2	186	205	252	277.8	213	249	288.6	337.4
M8	UNF	1.0	12	17	16.3	23	19	27	25.7	36.6	22	31	29.8	42
M10	UNF	1.25	20	29	27.1	39.3	35	47	47.4	63.7	40	52	54.2	70.5
M12	UNF	1.25	31	41	42	55.6	56	68	75.9	92.1	62	75	84	101.6
M14	UNF	1.5	52	64	70.5	86.7	90	106	122	143.6	107	124	145	168
M16	UNF	1.5	69	83	93.5	112.5	120	138	162.6	187	140	158	189.7	214.1
M18	UNF	1.5	100	117	136	158.5	177	199	239.8	269.6	202	231	273.7	313
M20	UNF	1.5	132	150	178.9	203.3	206	242	279.1	327.9	246	289	333.3	391.6

Use the above torques when special torque is not given.

NOTE: These values apply to fasteners as received from supplier, dry, or when lubricated with normal engine oil. They do not apply if extreme pressure lubricants are used.

WARRANTY

12

PRONOVOST warrants this product to the initial purchaser for the period of one year from the date of purchase against defects in materials and workmanship.

We will replace or repair defective parts free of charge if they are returned to our plant in St-Tite, Quebec, Canada.

Transportation charges are the responsibility of the customer. This warranty is not transferable.

Hydraulic cylinders and motors are covered by the manufacturer of these items.

The PTO shafts are warranted by the manufacturer and cover **only** defects in material and workmanship, and is conditional to recommended use and installation only.

All PRONOVOST spare parts purchased are covered by a three (3) month warranty.

This warranty becomes void and nul if the equipment is modified, breaks down as the result of an accident, is not operated according to manufacturer's recommendations, damaged by negligence or if maintenance has not been carried out as specified.

Our obligation is limited to the replacement or repair of the defective part. PRONOVOST accepts no responsibility for direct or indirect consequential damages of any kind.

Ce manuel est aussi disponible en français.
Veuillez téléphoner.



INNOVATION - EXCELLENCE

LES MACHINERIES PRONOVOST INC.

260, route 159,

Saint-Tite, Quebec, Canada, G0X 3H0

Tel.: (418) 365-7551, Fax: (418) 365-7954

www.pronovost.qc.ca