



**OPERATOR'S / PARTS  
MANUAL**



***Snowblowers***  
**Models**

**P-INV-74**



Copyright © Les Machineries Pronovost Inc., 2010

All rights reserved.  
Printed in Canada.

---

---

# ***TABLE OF CONTENTS***

---

---

<b>Section</b>	<b>Item</b>	<b>Page</b>
<b>1</b>	<b>Introduction .....</b>	<b>5</b>
<b>2</b>	<b>Safety .....</b>	<b>6</b>
	General Safety .....	6
	Safety in Operation .....	6
	Safety with Maintenance .....	7
	Safety in Transport .....	7
	Safety in Storage .....	7
<b>3</b>	<b>Decals .....</b>	<b>8</b>
	Safety Decals .....	8
	Maintenance Decals .....	11
<b>4</b>	<b>Assembly .....</b>	<b>12</b>
	General assembly .....	12
<b>5</b>	<b>Start-up .....</b>	<b>13</b>
	Basic Start-up Procedures .....	13
<b>6</b>	<b>Maintenance .....</b>	<b>14</b>
<b>7</b>	<b>Storage .....</b>	<b>15</b>
<b>8</b>	<b>Trouble Shooting .....</b>	<b>16</b>
<b>9</b>	<b>Specifications .....</b>	<b>18</b>
<b>10</b>	<b>Parts List .....</b>	<b>19</b>
	Snowblowers P-INV-74 .....	19
	Semi-industrial Chute PSIG-INV-GR1 .....	22
	Options .....	23
	P.T.O. Shaft 8114-EG .....	24
	Gear Box 8251 .....	25
	Cylinder 25TR04 .....	26
	Hydraulic Motor MLH100, MLH125 & MLH250 .....	27
<b>11</b>	<b>Torque Chart .....</b>	<b>28</b>
<b>12</b>	<b>Warranty .....</b>	<b>29</b>



---

---

# INTRODUCTION

---

## CONGRATULATIONS!

Thank you for choosing PRONOVOST. We are confident this equipment will meet your requirements in terms of quality, performance and reliability.

This manual was prepared to assist you in the safe operation of your new Snowblower. It contains important information which will help you achieve excellent returns with your Snowblower for years to come.

Please read this manual completely before operating your Snowblower and keep it for future reference.

Before starting the machine, you or any other person who will be operating the Snowblower must familiarize yourself with the safety recommendations and the operating instructions. Please read carefully and be sure to understand and follow all recommendations and procedures.

In this manual, the right and left sides are identified as shown on Figure 1.

If you require additional information on your Snowblower, please contact your PRONOVOST Dealer.

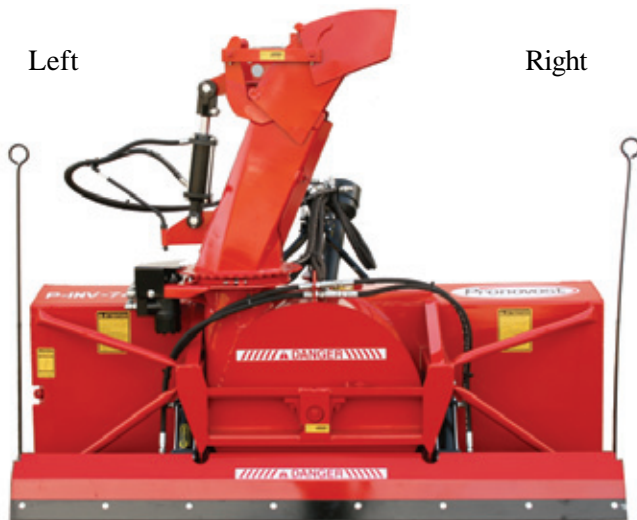

Figure 1

**NOW** take a moment to enter the model, serial number and the date of purchase of your Snowblower in the space provided.

When ordering parts from your Dealer, please refer to these numbers for a fast and efficient service. Use PRONOVOST parts for replacement.

The model and serial numbers are on the name plate shown on Fig. 2.



Figure 2

MODEL: \_\_\_\_\_ ✍

SERIAL NO: \_\_\_\_\_ ✍

DATE OF PURCHASE: \_\_\_\_\_ ✍

---

---

# SAFETY

---

## GENERAL SAFETY

2

### WHEN YOU SEE THIS SYMBOL



**ATTENTION!**

**BE ALERT  
YOUR SAFETY IS INVOLVED**

This symbol «SAFETY ALERT» is used in this manual and on the safety decals on the Snowblower. It warns you of the possibility of danger. Carefully read, understand and follow all safety recommendations before operating the Snowblower.

- 1) Careful operation is the best assurance against accidents. Carefully read this manual and follow all recommendations before operating your Snowblower. It is the owner's responsibility to make sure that anyone who will operate the Snowblower will read this manual before operating the equipment.
- 2) Familiarize yourself with all controls and always be ready to stop the Snowblower quickly in case of emergency.
- 3) Never let a child operate the Snowblower.
- 4) Do not modify the Snowblower. Any non authorized modification may affect the efficiency and/or safety of the equipment and will automatically void the warranty.
- 5) Never operate the Snowblower with defective parts or if damaged in any way. Have it repaired before operating.
- 6) Make sure all fasteners are in place and properly secured or tightened. Refer to torque chart on page 28.
- 7) Avoid wearing loose fitting clothing when working with the Snowblower. These could get entangled in moving parts of the equipment and cause accidents.

- 8) Prolonged exposure to noise may hamper hearing. Protect yourself by wearing adequate protection devices.
- 9) Hydraulic fluids under pressure can damage your skin. Do not use your hands to locate a leak.
- 10) Before the beginning of the snow season, inspect all areas where the Snowblower will be used and remove any object which may cause an accident and/or damage the equipment.
- 11) Never operate your Snowblower in poor visibility or without proper lighting conditions.

## SAFETY IN OPERATION

- 1) Be sure there are no obstructions around the equipment and that no one stands near the equipment when in operation.
- 2) Do not operate an engine in a confined or non ventilated area.
- 3) Do not perform any adjustments, cleaning, maintenance or repairs with the engine running. The engine must be stopped and the P.T.O. disengaged. Preferably remove the key from the ignition.
- 4) Wear adequate clothing when working in cold or windy conditions.
- 5) Before operating, make sure the P.T.O. is properly installed and secured.
- 6) Before starting-up the Snowblower, make sure the auger and drum areas are free of ice.
- 7) Put P.T.O. control in neutral position before starting engine.
- 8) Keep hands, feet and clothing away from moving parts of the Snowblower. Stay away from the discharge chute.

---

---

## ***SAFETY (cont'd)***

---

- 9) Before unplugging the chute, always disengage the P.T.O., stop the engine and relieve all hydraulic pressures.
- 10) Do not operate in excessive inclined conditions. Be careful when turning in slopes.
- 11) Never operate your Snowblower with missing guards or without protective devices in place.
- 12) Do not operate your Snowblower near buildings, windows or other vehicles without prior and proper adjustment of the chute deflector.
- 13) Never aim discharge chute towards people or animals. This may cause serious injuries.
- 14) Always reduce operating speed in slippery conditions.
- 15) Be careful when backing-up, make sure you have good visibility.
- 16) Always be on the lookout for objects which may enter the Snowblower.
- 17) If undue vibrations are felt, disengage the P.T.O., stop the motor and look for the cause of the vibration. Vibration is usually the indication of a problem.
- 18) At the end of the operation, disengage the P.T.O., lower the Snowblower, put transmission in neutral, apply parking brake, stop engine and remove the key from the ignition.

### ***SAFETY WITH MAINTENANCE***

- 1) Perform the Snowblower maintenance according to recommendations contained in this manual.

- 2) Stop engine and relieve all hydraulic pressures before doing inspection, maintenance or repairs.
- 3) Never perform any work under the Snowblower while it is supported only by the tractor's hydraulic system. It must be completely supported by wooden blocks or other safe means.

### ***SAFETY IN TRANSPORT***

- 1) On public roads, use proper safety lights and check local regulations.
- 2) Be alert while driving on the road. Never carry passengers.
- 3) Always disengage P.T.O. while moving from one area of work to another.
- 4) It is recommended to use both brake pedals simultaneously for better control.
- 5) The recommended road speed should be such as to maintain full control over steering and braking.
- 6) Be careful while backing up, make sure you have good visibility.

### ***SAFETY IN STORAGE***

- 1) Provide adequate supports to prevent any accidental overturning of the Snowblower.
- 2) Do not let children play in the area where the Snowblower is stored.

**2**

# DECALS

## SAFETY DECALS

The safety decals are affixed wherever special safety precautions are indicated. Locate them on the machine and read them carefully. If a decal is damaged, lost or illegible, install a new one. The following photos indicate where each one must be installed.

3

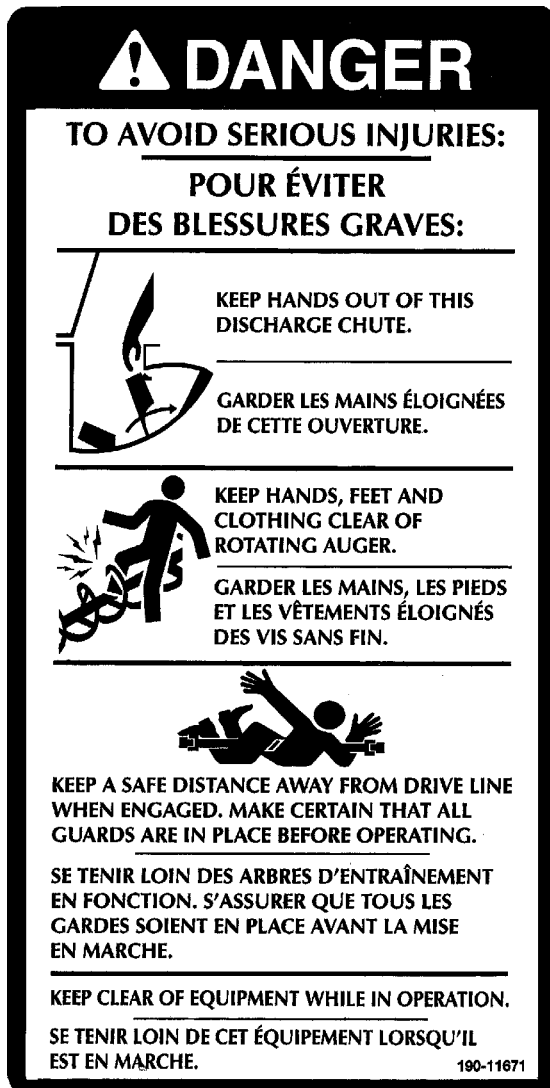

Figure 3  
Decal A

Part no.: 190-11671

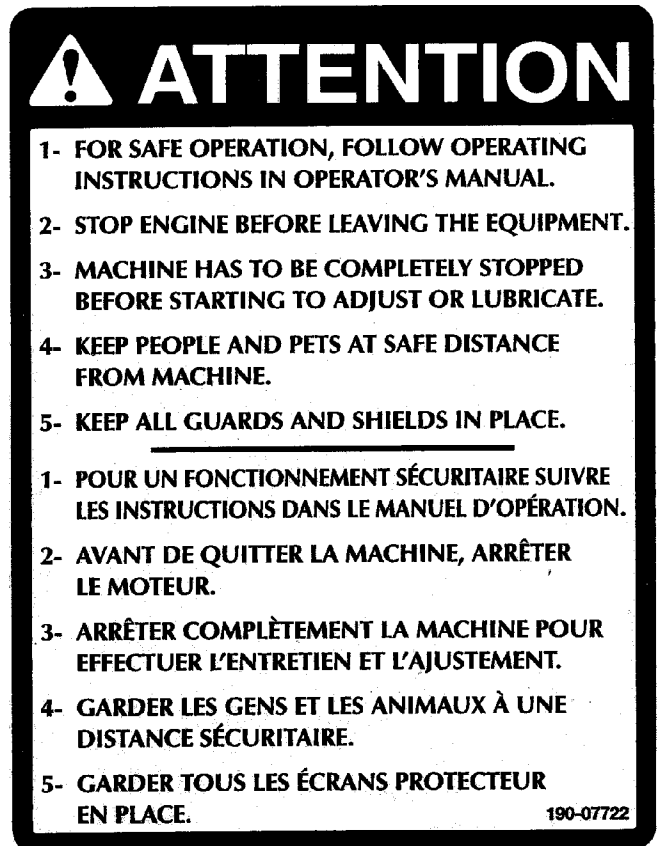

Figure 4  
Decal B

Part no.: 190-07722



Figure 5  
Decal C

Part no.: A103



Figure 6



# DECALS (cont'd)

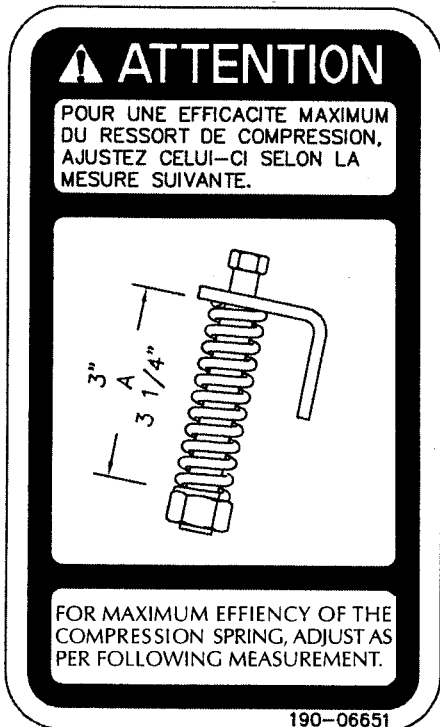

Figure 7  
Decal D

Part no.: 190-06651

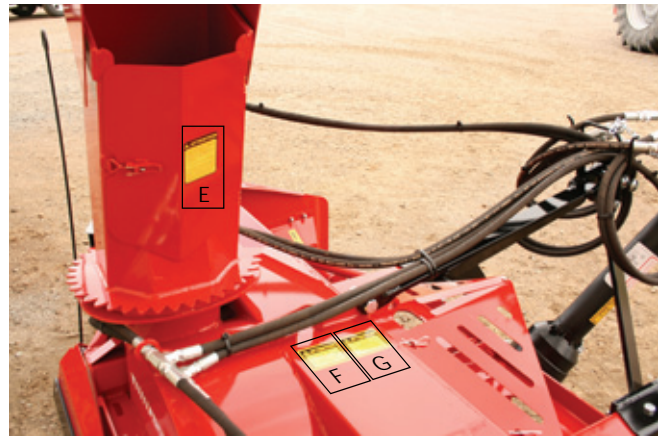

Figure 9

3

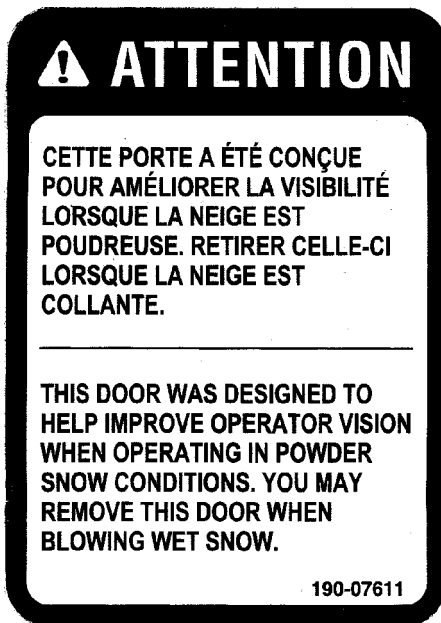

Figure 8  
Decal E

Pièce no.: 190-07611

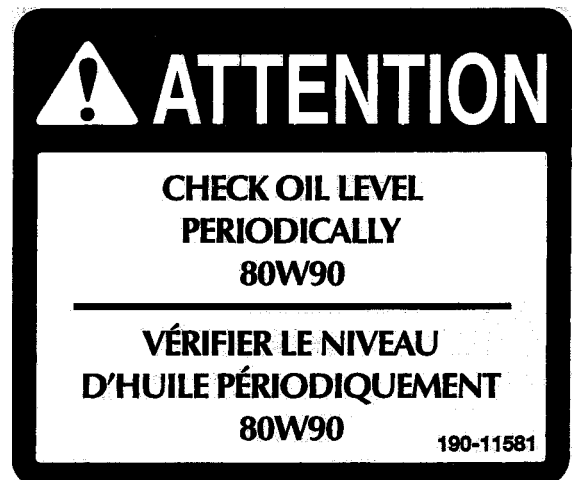

Figure 10  
Decal F

Part no.: 190-11581

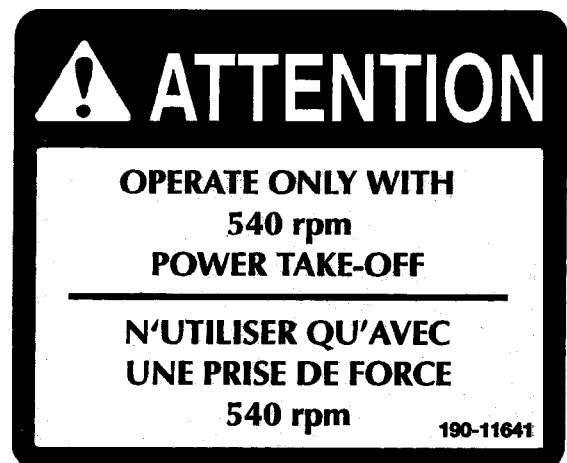

Figure 11  
Decal G

Part no.: 190-11641

**DECALS (cont'd)**

**3**

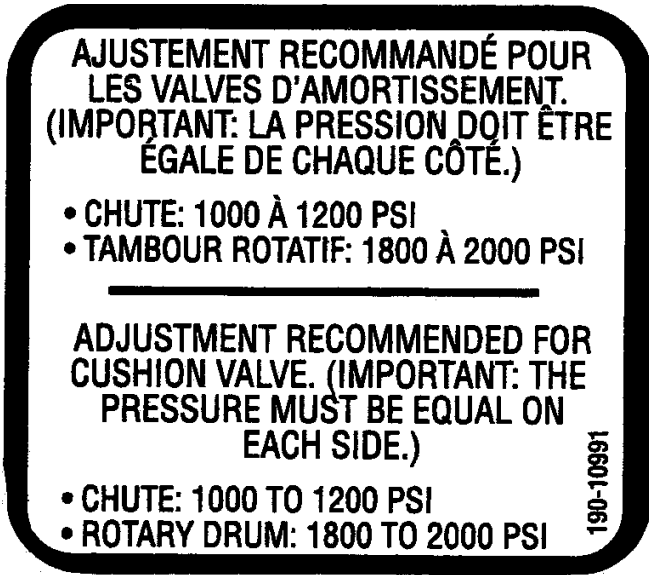

Figure 12  
Decal H

Part no.: 190-10991

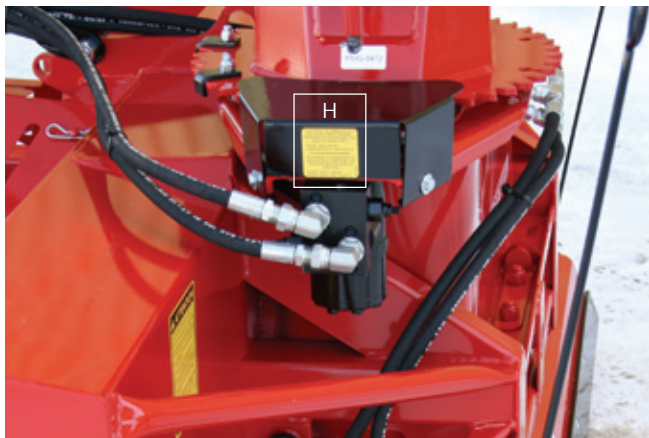

Figure 13



Figure 14  
Part no.: A108

## DECALS (cont'd)

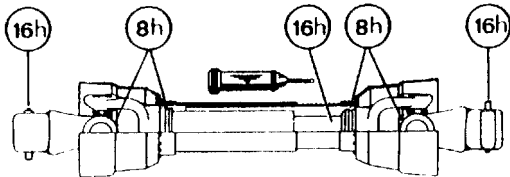

Figure 15  
Part no.: A 109

## MAINTENANCE DECALS

The maintenance decals indicate the points requiring lubrication. Refer to maintenance section for more details.



Figure 16

Part no.: A 106

3

---

# ASSEMBLY

---



4

Figure 17

## ASSEMBLY

- 1) The Snowblower is shipped partly assembled.
- 2) Install 3-point system according to the model of your Snowblower. (See section 10 for parts numbers). Use the holes most convenient to the type of tractor used (Fig. 17).
- 3) Install P.T.O. shaft with the shear pin end onto the Snowblower gear box. Then attach safety shield support chain as shown. **WARNING:** The telescoping tubes of the drive shaft must never be allowed to bottom out while maintaining a minimum overlap of 6 inches.
- 4) If you install a hydraulic cylinder on the chute deflector, use model 25TR04 cylinder.
- 5) When installing chute, grease the groove of the UHMW slide in order to prevent the corrosion of the rim of the chute.
- 6) For the installation of the chute rotation mechanism, please refer to parts section, according to the type used.

---

# STARTING-UP

---



Figure 18



Figure 19



Figure 20

## START-UP PROCEDURES

- 1) Check oil level in gearbox. Adjust to required oil level as per drawing in Parts List section. Use SAE 80W90 oil.
- 2) Lubricate all points with a good quality multipurpose grease.
- 3) Check chain take-up adjustment. The spring maintaining the tension must be compressed to a length between 3" and 3 1/4" (Fig. 18).
- 4) Verify for adequate tightness of all fastening devices. Refer to torque chart on page 28.
- 5) Make sure of a 540 RPM input to your snowblower.
- 6) Check impeller adjustment. The tip of the blades should be approximately 1/8" to 3/16" from the discharge wall of the drum. If necessary, adjust impeller by using both adjustment settings (Fig. 19 & Fig. 20) simultaneously.
- 7) In order to avoid damaging your snowblower, adjust the speed of descent of your 3 point hitch to prevent striking the ground too hard.
- 8) Adjust the hydraulic flow in order to have a good control of the rotation speed of the chute.

5

---

---

# MAINTENANCE

---

- 1) Wipe off all grease fittings with a clean cloth before adding grease in order to avoid injecting dirt and sand.
- 2) Repair or replace damaged grease fittings.
- 3) Lubricate all grease fittings every 8 hours of operation.
- 4) Oil drive chain every 8 hours of operation.
- 5) Lubricate P.T.O. shaft as indicated below:
- 7) Check tension of drive chain every 24 hours of operation and adjust if necessary.
- 8) Check for tightness of bearing collars every 48 hours of operation.
- 9) Change gearbox oil once a year. Adjust to required oil level as per drawing in Parts List section. Use SAE 80W90 oil.
- 10) Check all nuts and bolts once a year. If necessary use torque chart on page 28.

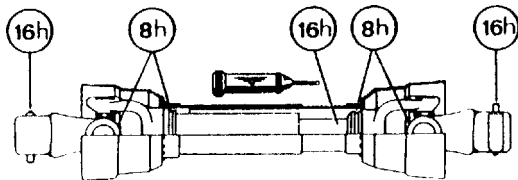

Pull out the P.T.O. and lubricate between the two tubes with low temperature grease. Drive line tubes must slide easily even in cold weather. Clean off old hardened grease and apply fresh grease as needed.

- 6) Check oil level in gear box once a month. Adjust to required oil level as per drawing in Parts List section. Use SAE 80W90 oil.
- 11) For the auger drive shaft, always use a grade 5 shear bolt.
- 12) For the PTO shaft, always use a grade 8.8 shear bolt at 540 RPM.
- 13) UHMW slides do not require lubrication except at the end of the season in order to prevent corrosion of steel components that are in contact with the UHMW material.

6

---

---

## ***STORAGE***

---

- 1) Store the Snowblower in a cool, dry place.
- 2) Support the Snowblower with wooden blocks.
- 3) Keep all piston rods in the retracted position. This will assure better protection against the elements.
- 4) Clean your Snowblower.
- 5) Thoroughly inspect all parts of the Snowblower. Replace or repair worn or defective parts.
- 6) Touch-up or repaint if necessary.
- 7) Lubricate all points before storage.

# TROUBLESHOOTING

## P.T.O. SHAFT

PROBLEM	POSSIBLE CAUSE	CORRECTION
<ul style="list-style-type: none"> <li>- Premature wear of U-joints and/ or bluish color of cross journals.</li> </ul>	<ul style="list-style-type: none"> <li>- Insufficient lubrication.</li> <li>- Excessive working angle.</li> <li>- Poor quality lubricant.</li> </ul>	<ul style="list-style-type: none"> <li>- Follow lubrication recommendations.</li> <li>- Replace defective U-joints.</li> <li>- Make sure the Snowblower inlet face is perpendicular to the ground and if possible readjust 3-point hitch in order to position the Snowblower further away from tractor.</li> <li>- Use high quality lubricant.</li> </ul>
<ul style="list-style-type: none"> <li>- Gripping or premature wear of telescoping members.</li> </ul>	<ul style="list-style-type: none"> <li>- Too much sliding under load.</li> <li>- Tube overlap too-short: minimum recommended is 6".</li> <li>- Insufficient lubrication.</li> <li>- Contaminants (sand, etc.).</li> </ul>	<ul style="list-style-type: none"> <li>- Avoid raising Snowblower while in operation.</li> <li>- Readjust 3-point hitch in order to position the snowblower closer to the tractor.</li> <li>- Follow lubrication recommendations.</li> <li>- Replace defective telescopic members.</li> </ul>
<ul style="list-style-type: none"> <li>- Damaged or jammed locking pin or bolt.</li> </ul>	<ul style="list-style-type: none"> <li>- Pin or orifice contaminated by sand, ice, etc.</li> <li>- Telescoping members too long, exerting pressure on locking device.</li> </ul>	<ul style="list-style-type: none"> <li>- Clean and grease.</li> <li>- Readjust 3-point hitch in order to position the Snowblower further away from tractor or shorten tubes.</li> </ul>
<ul style="list-style-type: none"> <li>- Premature wear of guard tube bearing ring.</li> </ul>	<ul style="list-style-type: none"> <li>- Lack of lubrication.</li> <li>- Wrong installation of guard chain.</li> <li>- Part of the guard in contact with the equipment.</li> </ul>	<ul style="list-style-type: none"> <li>- Follow lubrication instructions.</li> <li>- Adjust chain to prevent interference between guard &amp; equipment.</li> <li>- Replace worn or damaged bearing rings.</li> </ul>
<ul style="list-style-type: none"> <li>- Cut or deformed safety guard tubes.</li> </ul>	<ul style="list-style-type: none"> <li>- Tubes in contact with the equipment.</li> </ul>	<ul style="list-style-type: none"> <li>- Eliminate any interference between tubes and equipment or tractor.</li> <li>- Replace damaged tubes.</li> </ul>

8



# ***TROUBLESHOOTING (cont'd)***

## ***SNOWBLOWER***

<b>PROBLEM</b>	<b>POSSIBLE CAUSE</b>	<b>CORRECTION</b>
- The snow is not being thrown as far as usual.	<ul style="list-style-type: none"> <li>- Tractor RPM too low.</li> <li>- Gap too wide between impeller blade tip and drum outlet wall.</li> <li>- Insufficient tractor HP.</li> </ul>	<ul style="list-style-type: none"> <li>- Raise P.T.O. speed to a minimum of 540 RPM.</li> <li>- Adjust impeller blades closer to drum outlet (1/8" to 3/16").</li> <li>- Reduce travel speed.</li> </ul>
- Frequent plugging of discharge chute.	<ul style="list-style-type: none"> <li>- Tractor RPM too low.</li> <li>- Tractor RPM reduced too early with snow still in the Snowblower.</li> <li>- Slippage of PTO clutch mechanism.</li> <li>- Wet snow condition.</li> </ul>	<ul style="list-style-type: none"> <li>- Raise P.T.O. speed to a minimum of 540 RPM.</li> <li>- Make sure the Snowblower is completely empty before reducing RPM, especially on tractors with foot controlled RPM.</li> <li>- Repare clutch.</li> <li>- Reduce travel speed.</li> <li>- Remove access panel.</li> </ul>
- The impeller will not turn.	<ul style="list-style-type: none"> <li>- Shear bolt broken on drive shaft.</li> </ul>	<ul style="list-style-type: none"> <li>- Replace shear bolt.</li> </ul>
- The auger will not turn.	<ul style="list-style-type: none"> <li>- Shear bolt broken on drive shaft.</li> <li>- Shear bolt broken on auger drive shaft.</li> <li>- Broken drive chain.</li> </ul>	<ul style="list-style-type: none"> <li>- Replace shear bolt.</li> <li>- Replace shear bolt.</li> <li>- Fix or replace chain.</li> </ul>
- The chute will not turn.	<ul style="list-style-type: none"> <li>- Broken key on motor.</li> <li>- Ice accumulation.</li> <li>- Wrong hydraulic connections.</li> </ul>	<ul style="list-style-type: none"> <li>- Replace the key.</li> <li>- Remove ice.</li> <li>- Check hydraulic connections.</li> </ul>

# ***SPECIFICATIONS***

<b>Model</b>	<b>P-INV-74</b>
Horse power recommended	35 to 65 HP
Working width	74"
Cutting height	28"
Height - chute base	30"
Drum diameter	26"
Depth of drum	9"
Impeller blades	4 blades
Number of shear bolts	1 for impeller, 1 on auger drive
Size of impeller shaft	1 9/16"
Height - impeller center	15"
Impeller RPM	540 RPM
Number of augers	1
Main auger diameter	16"
Drive chain	No. 60
Oil bath sealed gear box	Included
Balanced impeller	Included
Balanced auger	Included
Scraper blade for snowblower	Included • Standard steel (3/8" x 2 1/2") - not reversible
	Opt. • Carbon steel 450 (1/2" x 3")
	Opt. • Stainless Steel (1/2" x 3")
Rear mount scraper blade	Option
Plow blade for rear mount scraper blade	Opt. • Standard steel
	Opt. • TIVAR
	Opt. • Stainless steel
Semi-industrial chute	With cylinder 25TR04 on the deflector included
Chute rotation mechanism	Hydraulic with motor MLH-125 included
	Antifriction ring included
P.T.O. Category	T50
Auger bearing /ductile iron casing	1 1/4"
Hose support	Included
Hitch category	Category 1 28 1/2" c/c
Weight (approx.)	900lbs

Design and specifications subject to change without notice.

# SNOWBLOWER P-INV-74

170-05463

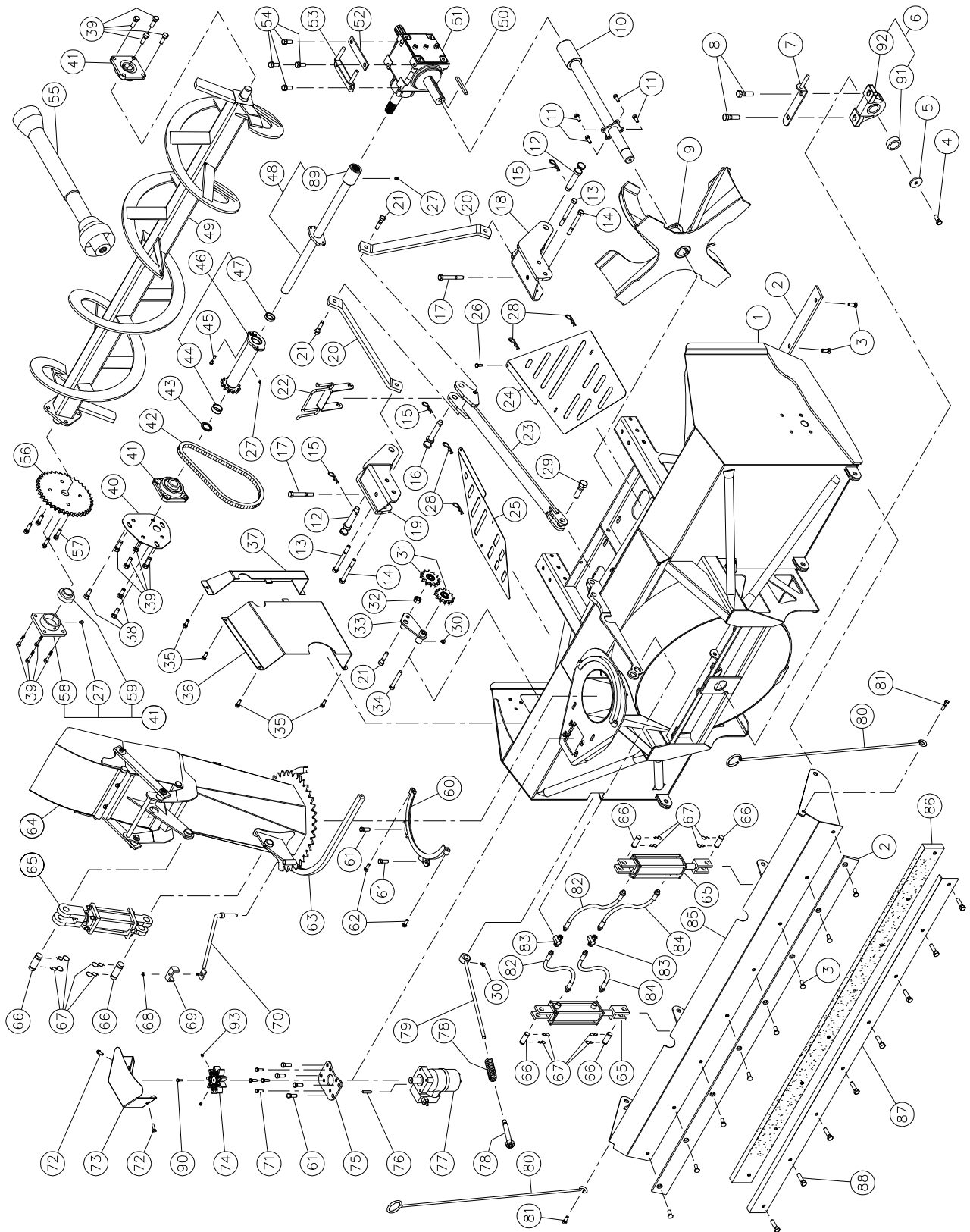

# SNOWBLOWER P-INV-74 (cont'd)

REF.	PART #	DESCRIPTION	QTY
1	120-07642	Frame P-INV-74 .....	1
2	140-25432	Scraper blade 3/8" x 2 1/2" x 72 3/4" lg standard steel .....	1
2	140-25432	Scraper blade 3/8" x 2 1/2" x 72 3/4" lg standard steel (rear mount scraper blade) .....	opt.
3	319-38280	Plow bolt 7/16" NC x 1 1/4" lg + lockwasher .....	8
3	319-38280	Plow bolt 7/16" NC x 1 1/4" lg + nut & lockwasher (rear mount scraper blade) (8) .....	opt.
4	300-40280	Bolt 1/2" NC x 1 1/4" lg .....	1
5	130-81581	Shaft end retainer .....	1
6	UCPE208-24	Bearing 1 1/2" .....	1
7	110-44301	Adjustment plate for impeller shaft + 2 nuts 1/2" NC .....	1
8	300-44355	Bolt 5/8" NC x 2 1/4" lg .....	2
9	110-44242	Impeller 26" ø x 9" - 4 blades .....	1
10	110-44282	Impeller shaft .....	1
11	300-36250	Bolt 3/8" NC x 1" lg + nylon locknut .....	4
12	6253	Pin category 1 .....	2
13	300-40520	Bolt 1/2" NC x 5" lg + nylon locknut .....	2
14	300-40490	Bolt 1/2" NC x 4 1/2" lg + nylon locknut .....	2
15	Std.	Hitch pin clip 5/32" .....	3
16	150-06012	Pin (top link) .....	1
17	300-40460	Bolt 1/2" NC x 4" lg + nylon locknut .....	2
18	110-44233	Right lower hitch .....	1
19	110-44234	Left lower hitch .....	1
20	140-25941	3-points side bar .....	2
21	300-40340	Bolt 1/2" NC x 2" lg + nylon locknut .....	3
22	110-33781	Hoses support .....	1
23	110-44372	Upper hitch .....	1
24	130-83744	Right guard .....	1
25	130-83743	Left guard .....	1
26	300-32220	Bolt 1/4" x 3/4" lg + nylon locknut .....	1
27	Std.	Grease fitting 1/4" - 28 straight .....	3
28	Std.	Hitch pin clip 1/8" x 2 9/16" .....	4
29	300-46370	Bolt 3/4" NC x 2 1/2" lg + nylon locknut .....	1
30	Std.	Grease fitting 1/4" - 28 elbow 90 deg. ....	2
31	8186	Idler sprocket # 60 .....	2
32	336-44000	Nut 5/8 NC .....	1
33	110-44401	Idler .....	1
34	300-40415	Bolt 1/2" NC x 3 1/4" lg + nylon locknut .....	1
35	300-36250	Bolt 3/8" x 1" lg + nylon locknut .....	6
36	110-45522	Interior chain guard (center) .....	1
37	110-45512	Interior chain guard (front) .....	1
38	300-40280	Bolt 1/2" x 1 1/4" lg + flat washer + nylon locknut .....	3
39	300-40310	Bolt 1/2" x 1 1/2" lg + nylon locknut .....	4
40	130-81811	Mounting plate for drive ass'y .....	1
41	UCFD207-20	Bearing 1 1/4" + flange & 2 grease fitting straight .....	3
42	190-12331	Chain #60 45 3/4" lg 61 links .....	1
42	26A60	Connecting link #60 .....	1
42	59-60	Offset link #60 .....	1
43	160-26791	Spacer for drive shaft .....	1
44	160-26501	Brass bushing 1 1/4" i.d. x 1 1/2" o.d. x 5/8" lg .....	1
45	300-32310	Bolt 1/4" NC x 1 1/2" lg grade 5 + nylon locknut .....	1
46	110-44351	Sprocket #60 + shearplate (including no. 44 & 47) .....	1
47	160-26511	Brass bushing 1 1/4" i.d. x 1 1/2" o.d. x 5/8" lg .....	1
48	110-44342	Auger drive shaft 27 3/32" lg hors tout (including no. 89) .....	1
49	110-44292	Auger .....	1
50	8030	Key for gearbox .....	1
51	8251	Gear box T27D .....	1
52	140-10571	Back plate .....	1

## SNOWBLOWER P-INV-74 (cont'd)

REF.	PART #	DESCRIPTION	QTY
53	110-44901	Adjustment plate for gearbox + 4 nuts 1/2" NC .....	1
54	300-40280	Bolt 1/2" NC x 1 1/4" lg + lock washer .....	4
55	8114-EG	P.T.O. shaft .....	1
56	8021	Sprocket 60 A38 T 1 1/4" ø .....	1
57	300-38310	Bolt 7/16" NC x 1 1/2" lg + two-way locknut .....	4
58	FD207	Flange for 2 grease fitting .....	3
59	UC207-20	Bearing 1 1/4" .....	3
60	110-02001	Retaining bracket .....	1
61	300-38280	Bolt 7/16" x 1 1/4" lg + flat washer + nylon locknut .....	6
62	300-34370	Bolt 5/16" x 2 1/2" lg + nylon locknut .....	2
63	6471	U-shaped UHMW ± 12" i.d. ....	1
64	170-05681	Semi-industrial chute .....	1
65	25TR04	Cylinder 2.5" x 4" standard .....	1
65	25TR04	Cylinder 2.5" x 4" standard (rear mount scraper blade) (2) .....	opt.
66	D-600-51	Pin 1" x 3" .....	2
66	D-600-51	Pin 1" x 3" (rear mount scraper blade) (4) .....	opt.
67	51472	Hitch pin clip (CP132H) .....	4
67	51472	Hitch pin clip (CP132H) (rear mount scraper blade) (8) .....	opt.
68	Std.	Nylon locknut 5/16" NC (1) .....	1
69	140-00881	Hoses mounting plate (1) .....	1
70	110-01121	Mounting support plate (1) .....	1
71	300-34250	Bolt 5/16" NC x 1" lg .....	4
72	300-34250	Bolt 5/16" NC x 1" lg + rondelle plate + nylon locknut .....	2
73	130-84091	Guard .....	1
74	110-44331	Sprocket 9 tooth .....	1
75	130-07911	Orbit motor support .....	1
76	8369	Key for hydraulic motor .....	1
77	MLH-125	Hydraulic orbit motor with cushion valve .....	1
78	110-01221	Threaded tube for idler adjustment .....	1
79	110-44411	Threaded rod for idler adjustment + nut 7/16" NC .....	1
80	190-02193	Proximity indicator (2) .....	opt.
81	321-40310	Cariage bolt 1/2" NC x 1 1/2" lg + nylon locknut (2) .....	opt.
82	190-13271	Hose 3/8" x 27" lg + 2 fittings 6U-106 (2) .....	opt.
83	5856x6x6	"T" 3/8" N.P.T. (2) .....	opt.
84	190-13281	Hose 3/8" x 33" lg + 2 fittings 6U-106 (2) .....	opt.
85	110-44442	Rear mount scraper blade frame .....	opt.
86	190-13121	TIVAR plow blade 1" x 4" x 72 3/4" lg .....	opt.
87	130-85641	TIVAR plow blade support 72 3/4" lg .....	opt.
88	319-39355	Plow bolt 7/16" NC x 2 1/4" + lock washer + nut ( 8 ) .....	opt.
89	6466	Splined adaptor 1 1/4" - 19 splines (welded) .....	1
90	300-32220	Bolt 1/4" NC x 3/4" lg .....	1
91	UC208-24	Bearing 1 1/2" .....	1
92	FE208	Flange for 2 grease fitting .....	1
93	323-36160	Hexagonal socket set screw 3/8" NC x 3/8" lg .....	2

# SEMI-INDUSTRIAL CHUTE PSIG-INV-GR1

170-5681

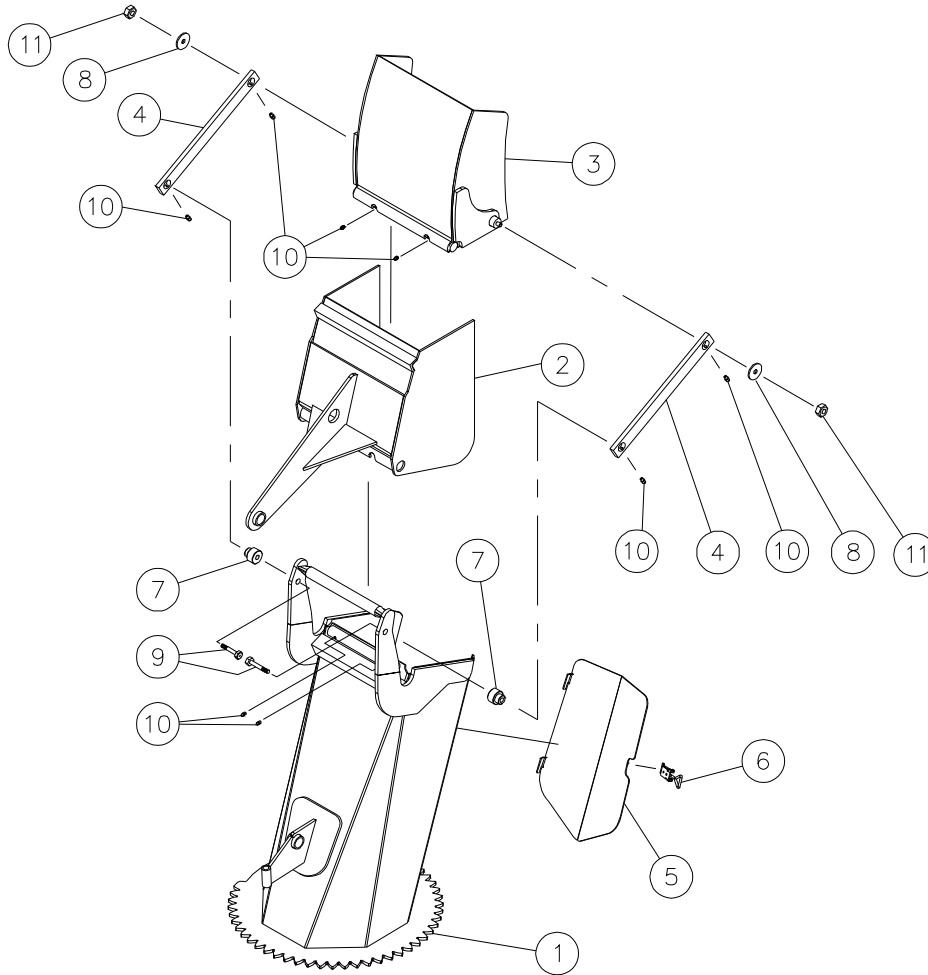

REF.	PART #	DESCRIPTION	QTY
1	110-45431	Chute base (serial number 33233 to 33916)	1
1	110-45432	Chute base (serial number 33917 and up)	1
2	110-22871	Lower chute deflector	1
3	110-22861	Upper chute deflector	1
4	140-14171	Connecting rod	2
5	110-46011	Access panel (serial number 33233 to 33916)	1
5	110-32762	Access panel (serial number 33917 and up)	1
6	8374	Adjustable clamp fastener (welded)	1
7	150-05391	Spacer for connecting rod	2
8	378-36500	Washer 25/64" i.d. x 1 1/2" o.d.	2
9	300-38340	Bolt 7/16" NC x 2" lg + flat washer + nylon locknut (thin)	2
10	Std.	Grease fitting 1/4"-28 straight	8
11	346-36000	Nylon locknut 3/8" NC	2

10

# OPTIONS

170-05781

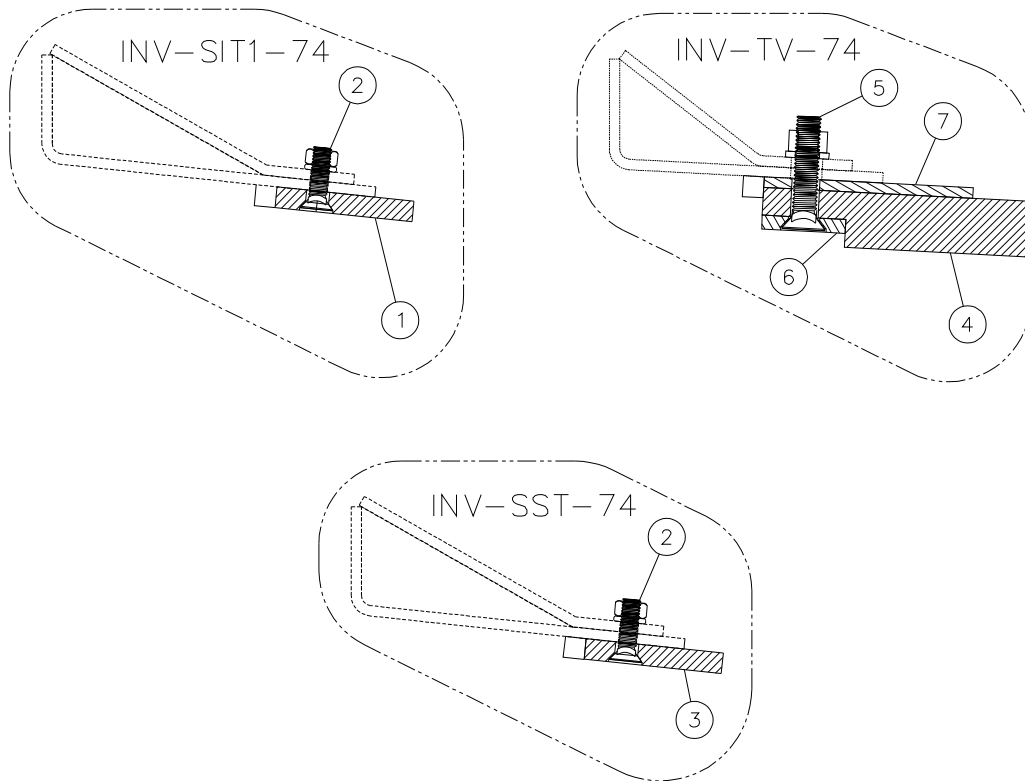

REF.	PART #	DESCRIPTION	QTY
1	130-85661	Semi-industrial scraper blade, carbon steel, not reversible, not sharpened 1/2" x 3" x 72 3/4" .....	1
2	319-38310	Plow bolt 7/16" NC x 1 1/2" lg + nut & lockwasher .....	8
3	130-85651	Semi-industrial scraper blade, stainless steel, not reversible, not sharpened 1/2" x 3" x 72 3/4" .....	1
4	190-13111	Scraper blade, TIVAR 1" x 4 3/4" x 72 3/4" .....	1
5	319-39340	Plow bolt 7/16" NC x 2" lg + nut & lockwasher .....	8
6	140-26001	Tivar blade bolting plate 1/4" x 1 1/2" x 72 3/4" lg .....	1
7	130-85631	TIVAR blade holder 3/16" x 3 3/4" x 72 3/4" lg .....	1

# P.T.O. SHAFT # 8114-EG (T50)

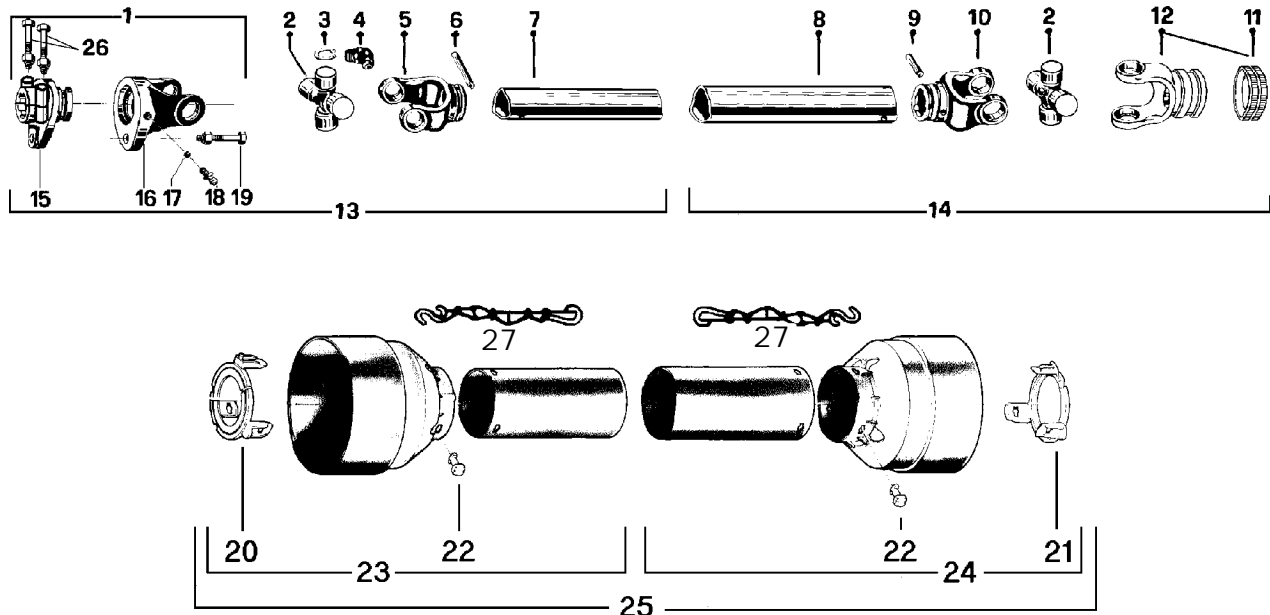

REF.	PART #	DESCRIPTION	QTY
1	8221	Safety shear yoke (2 bolts) .....	1
2	8073	U joint + 4 retaining rings + 1 grease fitting .....	2
3	8061	Retaining ring .....	8
4	8110	Grease fitting .....	2
5	8079	Yoke for inner tube .....	1
6	6341	Stopper for inner tube .....	1
7	8077	Inner tube .....	1
8	8076	Outer tube .....	1
9	8142	Stopper for outer tube .....	1
10	8074	Yoke for outer tube .....	1
11	8363	Collar kit .....	1
12	8113	Yoke with hole 1 3/8"-6 splines + yoke stopper .....	1
13	8235	P.T.O. section, side with safety shear bolt, inner part, with protector .....	1
14	8236	P.T.O. section, side without safety shear bolt, outer part, with protector .....	1
15	8223	Adaptor (2 bolts) .....	1
16	8069	Yoke and shearplate .....	1
17	8070	Ball .....	17
18	8071	Grease fitting .....	1
19	8072	Safety shear bolt M10 x 50mm .....	1
20	8084-E	Bearing ring for inner guard tube .....	1
21	8083-E	Bearing ring for outer guard tube .....	1
22	8109	Stopper .....	6
23	8086	Inner shield .....	1
24	8085	Outer shield .....	1
25	8087	Complete shield .....	1
26	8222	Bolt M12 x 70mm .....	2
27	8308	Safety chain .....	2



# GEAR BOX # 8251 (T27D)

170-05581

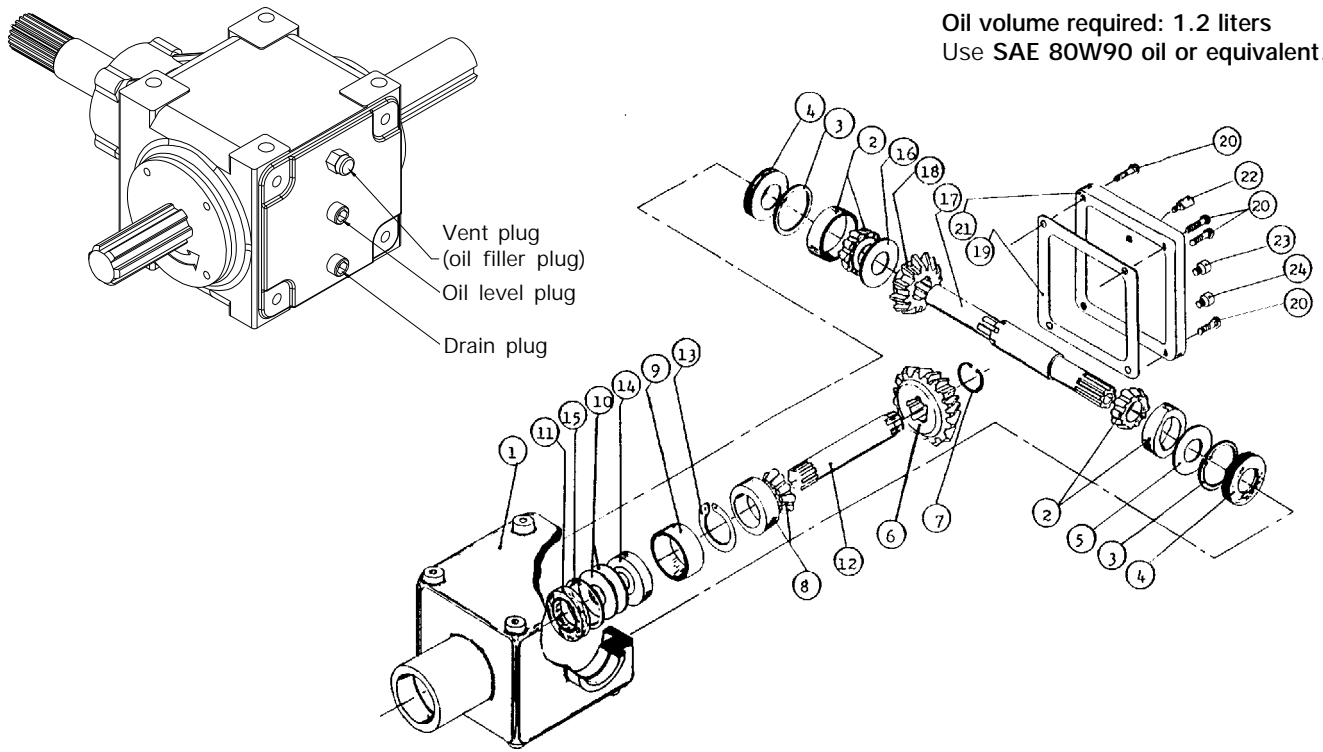

REF.	PART #	DESCRIPTION	QTY
1	8043	Casing .....	1
2	30208-A	Roller bearing .....	2
3	8045	Inside circlip 80mm .....	2
4	8046	Oil seal 40 x 80 x 12mm .....	2
5	8047	Adjusting washer .....	1
6	8048	Gear Z18 .....	1
7	8049	Outside circlip 40mm .....	1
8	30207-A	Roller bearing .....	1
9	8051	Spacer ring .....	1
10	8052	Adjusting washer .....	2
11	8053	Oil seal 35 x 72 x 12mm .....	1
12	8054	Side shaft (1 1/4" - 19 splines) .....	1
13	8055	Inside circlip 72mm .....	1
14	6207-2RS	Ball bearing .....	1
15	8057	Outside circlip 35mm .....	1
16	8058	Adjusting washer .....	1
17	8252	Impeller shaft (1.575" & 1 3/8" - 6 splines) .....	1
18	8060	Gear Z-18 .....	1
19	- - -	Use silicone caulking .....	-
20	8062	Bolt M10 x 14mm .....	4
21	8063	Cover .....	1
22	8065	Vent plug (oil filler plug) .....	1
23	8064	Plug (oil level) .....	1
24	8064	Plug (oil drain) .....	1

# CYLINDER 25TR04

170-02141

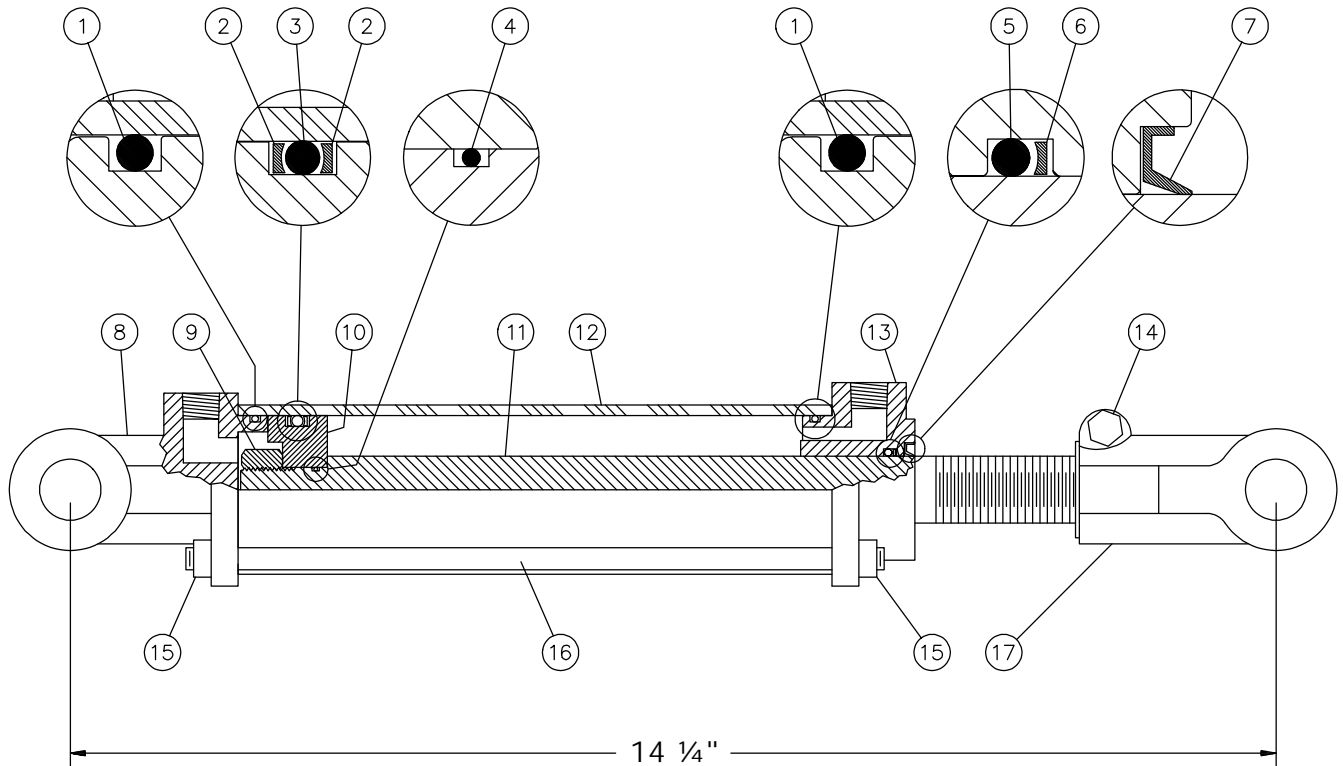

REF.	PART #	DESCRIPTION	QTY
1	See #RK25TR	O-ring 1/8" x 2 1/4" x 2 1/2" .....	2
2	See #RK25TR	Back-up 2 1/2" o.d. x 3/16 ø .....	2
3	See #RK25TR	O-ring 3/16" x 2 1/8" x 2 1/2" .....	1
4	See #RK25TR	O-ring 1/16" x 5/8" x 3/4" .....	1
5	See #RK25TR	O-ring 1/8" x 1 1/8" x 1 3/8" .....	1
6	See #RK25TR	Back-up 1 3/8" o.d. x 1/8" ø .....	1
7	See #RK25TR	Wiper 1 1/8" i.d. x 1 5/8" o.d. ....	1
8	492401	Yoke (for 2 1/2" tube) .....	1
9	338-46000	Nut 3/4" NF .....	1
10	4924-31	Piston 2 1/2" ø .....	1
11	491980-04	Piston rod 1 1/8" .....	1
12	491668-04	Cylinder body 2 1/2" ø .....	1
13	492421	Head (for 2 1/2" tube) .....	1
14	300-36355	Bolt 3/8" NC x 2 1/4" + nut .....	1
15	336-36000	Nut 3/8" NC .....	8
16	Std.	Threaded rod 3/8" NC x 8" lg .....	4
17	458599	Yoke (for 1 1/8" rod) .....	1
NI*	8183	Pin 1" ø + cotter pin .....	2
NI*	RK25TR	Repair kit for cylinder 2 1/2" (includes # 1, 2, 3, 4, 5, 6, & 7) .....	1

\*NI = NOT ILLUSTRATED

# HYDRAULIC MOTOR MLH100, MLH125 & MLH250



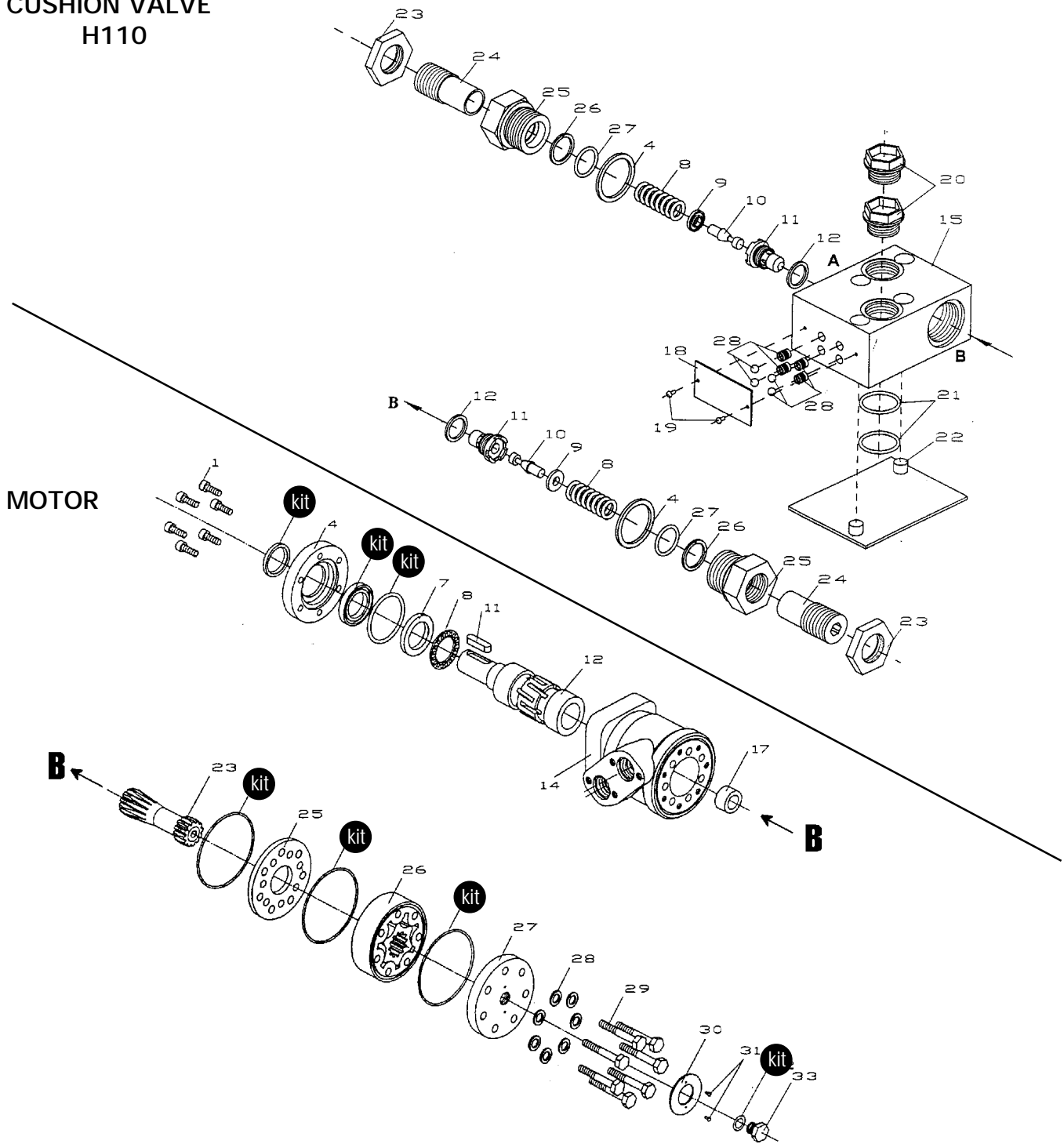



## CUSHION VALVE H110







REF.	PART #	DESCRIPTION	QTY
kit	8368	Set of seals.....	1
11	8369	Key for "Orbit" motor.....	1

# TORQUE CHART

## TORQUE SPECIFICATION TABLE

Thread UNC and UNF		Grade 2 				Grade 5   				Grade 8*   			
Bolt size		Torque				Torque				Torque			
Inches	mm	Pound feet		Newton meters		Pound feet		Newton meters		Pound feet		Newton meters	
		min.	max.	min.	max.	min.	max.	min.	max.	min.	max.	min.	max.
1/4	6.35	5	6	6.8	8.13	9	11	12.2	14.9	12	15	16.3	30.3
5/16	7.94	10	12	13.6	16.3	17	20.5	23.1	27.8	24	29	32.5	39.3
3/8	9.53	20	23	27.1	31.2	35	42	47.5	57.0	45	54	61.0	73.2
7/16	11.11	30	35	40.7	47.4	54	64	73.2	86.8	70	84	94.9	113.9
1/2	12.70	45	52	61.0	70.5	80	96	108.5	130.2	110	132	149.2	179.0
9/16	14.29	65	75	88.1	101.6	110	132	149.2	179.0	160	192	217.0	260.4
5/8	15.88	95	105	128.7	142.3	150	180	203.4	244.1	220	264	298.3	358.0
3/4	19.05	150	185	203.3	250.7	270	324	366.1	439.3	380	456	515.3	618.3
7/8	22.23	160	200	216.8	271.0	400	480	542.4	650.9	600	720	813.6	976.3
1	25.40	250	300	338.8	406.5	580	696	786.5	943.8	900	1080	1220.4	1464.5
1 1/8	25.58	-	-	-	-	800	880	1084.8	1193.3	1280	1440	1735.7	1952.6
1 1/4	31.75	-	-	-	-	1120	1240	1518.7	1681.4	1820	2000	2467.9	2712.0
1 3/8	34.93	-	-	-	-	1460	1680	1979.8	2278.1	2380	2720	3227.3	3688.3
1 1/2	38.10	-	-	-	-	1940	2200	2630.6	2983.2	3160	3560	4285.0	4827.4

\* Thick nuts must be used with grade 8 bolts.

Size of screw	Thread	Pitch (mm)	Grade 4T  				Grade 7T 				Grade 8T  			
			Torque				Torque				Torque			
			Pound feet		Newton meters		Pound feet		Newton meters		Pound feet		Newton meters	
		min.	max.	min.	max.	min.	max.	min.	max.	min.	max.	min.	max.	
M6	UNC	1.00	3.6	5.8	4.9	7.9	5.8	9.4	7.9	12.7	7.2	10	9.8	13.6
M8	UNC	1.25	7.2	14	9.8	19	17	22	23	29.8	20	26	27.1	35.2
M10	UNC	1.5	20	25	27.1	33.9	34	40	46.1	54.2	38	46	51.5	62.3
M12	UNC	1.75	28	34	37.9	46.1	51	59	69.1	79.9	57	66	77.2	89.4
M14	UNC	2.0	49	56	66.4	75.9	81	93	109.8	126	96	109	130.1	147.7
M16	UNC	2.0	67	77	90.8	104.3	116	130	157.2	176.2	129	145	174.8	196.5
M18	UNC	2.0	88	100	119.2	136	150	168	203.3	227.6	175	194	237.1	262.9
M20	UNC	2.5	108	130	146.3	176.2	186	205	252	277.8	213	249	288.6	337.4
M8	UNF	1.0	12	17	16.3	23	19	27	25.7	36.6	22	31	29.8	42
M10	UNF	1.25	20	29	27.1	39.3	35	47	47.4	63.7	40	52	54.2	70.5
M12	UNF	1.25	31	41	42	55.6	56	68	75.9	92.1	62	75	84	101.6
M14	UNF	1.5	52	64	70.5	86.7	90	106	122	143.6	107	124	145	168
M16	UNF	1.5	69	83	93.5	112.5	120	138	162.6	187	140	158	189.7	214.1
M18	UNF	1.5	100	117	136	158.5	177	199	239.8	269.6	202	231	273.7	313
M20	UNF	1.5	132	150	178.9	203.3	206	242	279.1	327.9	246	289	333.3	391.6

Use the above torques when special torque is not given.

NOTE: These values apply to fasteners as received from supplier, dry, or when lubricated with normal engine oil. They do not apply if extreme pressure lubricants are used.

---

---

# WARRANTY

---

PRONOVOST warrants this product to the initial purchaser for the period of one year from the date of purchase against defects in materials and workmanship.

We will replace or repair defective parts free of charge if they are returned to our plant in St-Tite, Quebec, Canada.

Transportation charges are the responsibility of the customer. This warranty is not transferable.

Hydraulic cylinders and motors are covered by the manufacturer of these items.

The PTO shafts are warranted by the manufacturer and cover **only** defects in material and workmanship, and is conditional to recommended use and installation only.

All PRONOVOST spare parts purchased are covered by a three (3) month warranty.

This warranty becomes void and nul if the equipment is modified, breaks down as the result of an accident, is not operated according to manufacturer's recommendations, damaged by negligence or if maintenance has not been carried out as specified.

Our obligation is limited to the replacement or repair of the defective part. PRONOVOST accepts no responsibility for direct or indirect consequential damages of any kind.





Ce manuel est aussi disponible en français.  
Veuillez téléphoner.



INNOVATION - EXCELLENCE

**LES MACHINERIES PRONOVOST INC.**  
260, Haut du Lac Sud (route 159),  
Saint-Tite, Quebec, Canada, G0X 3H0  
Tel.: (418) 365-7551, Fax: (418) 365-7954  
[www.pronovost.qc.ca](http://www.pronovost.qc.ca)