



**OPERATOR'S / PARTS  
MANUAL**



***Industrial snowblower***  
**Model**  
**PGV-1022TRC-220**



Copyright © Les Machineries Pronovost Inc., 2012

All rights reserved.  
Printed in Canada.

---



---

# **TABLE OF CONTENTS**

---

<b>Section</b>	<b>Item</b>	<b>Page</b>
<b>1</b>	<b>Introduction .....</b>	<b>5</b>
<b>2</b>	<b>Safety .....</b>	<b>6</b>
	General Safety .....	6
	Safety in operation .....	6
	Safety with maintenance .....	7
	Safety in transport .....	7
	Safety in storage .....	7
<b>3</b>	<b>Decals .....</b>	<b>8</b>
	Safety Decals .....	8
	Maintenance Decals .....	10
<b>4</b>	<b>Assembly .....</b>	<b>13</b>
	General assembly .....	13
<b>5</b>	<b>Start-up .....</b>	<b>14</b>
	Basic start-up Procedures .....	14
<b>6</b>	<b>Maintenance .....</b>	<b>15</b>
<b>7</b>	<b>Storage .....</b>	<b>16</b>
<b>8</b>	<b>Trouble Shooting .....</b>	<b>17</b>
<b>9</b>	<b>Specifications .....</b>	<b>19</b>
<b>10</b>	<b>Parts List .....</b>	<b>20</b>
	Snowblower PGV-1022TRC-220 .....	20
	Industrial Chute PCTC-IND .....	24
	Industrial Chute PCTC-INDR .....	26
	Lateral Blades .....	28
	Inverter Reduction Gear Box # 9717 - 250 HP .....	29
	Oil cooler # RH250-PGV1022 .....	30
	P.T.O. # 9599, 9604 .....	31
	Gear Box # 9597 .....	32
	Cylinder 25TR08 .....	33
	Cylinder 15L12 .....	34
	Cylinder 15PC32 .....	35
	Hydraulic Motor MLH315 .....	36
<b>11</b>	<b>Torque chart .....</b>	<b>37</b>
<b>12</b>	<b>Warranty .....</b>	<b>38</b>



# INTRODUCTION

## CONGRATULATIONS!

Thank you for choosing PRONOVOST. We are confident this equipment will meet your requirements in terms of quality, performance and reliability.

This manual was prepared to assist you in the safe operation of your new Snowblower. It contains important information which will help you achieve excellent returns with your Snowblower for years to come.

Please read this manual completely before operating your Snowblower and keep it for future reference.

Before starting the machine, you or any other person who will be operating the Snowblower must familiarize yourself with the safety recommendations and the operating instructions. Please read carefully and be sure to understand and follow all recommendations and procedures.

In this manual, the right and left sides are identified as shown on Figure 1a.

If you require additional information on your Snowblower, please contact your PRONOVOST Dealer.



Figure 1a

**NOW** take a moment to enter the model, serial number and the date of purchase of your Snowblower in the space provided.

When ordering parts from your Dealer, please refer to these numbers for a fast and efficient service. Use PRONOVOST parts for replacement.

The model and serial numbers are on the name plate shown on Fig. 1b.



Figure 1b

MODEL: \_\_\_\_\_ ✍

SERIAL NO: \_\_\_\_\_ ✍

DATE OF PURCHASE: \_\_\_\_\_ ✍

---

---

# ***SAFETY***

---

## ***GENERAL SAFETY***

**2**

### **WHEN YOU SEE THIS SYMBOL**



**ATTENTION!**

**BE ALERT  
YOUR SAFETY IS INVOLVED**

This symbol «**SAFETY ALERT**» is used in this manual and on the safety decals on the Snowblower. It warns you of the possibility of danger. Carefully read, understand and follow all safety recommendations before operating the Snowblower.

- 1) Careful operation is the best assurance against accidents. Carefully read this manual and follow all recommendations before operating your Snowblower. It is the owner's responsibility to make sure that anyone who will operate the Snowblower will read this manual before operating the equipment.
- 2) Familiarize yourself with all controls and always be ready to stop the Snowblower quickly in case of emergency.
- 3) Never let a child operate the Snowblower.
- 4) Do not modify the Snowblower. Any non authorized modification may affect the efficiency and/or safety of the equipment and will automatically void the warranty.
- 5) Never operate the Snowblower with defective parts or if damaged in any way. Have it repaired before operating.
- 6) Make sure all fasteners are in place and properly secured or tightened. Refer to torque chart on page 37.
- 7) Avoid wearing loose fitting clothing when working with the Snowblower. These could get entangled in moving parts of the equipment and cause accidents.

- 8) Prolonged exposure to noise may hamper hearing. Protect yourself by wearing adequate protection devices.
- 9) Hydraulic fluids under pressure can damage your skin. Do not use your hands to locate a leak.
- 10) Before the beginning of the snow season, inspect all areas where the Snowblower will be used and remove any object which may cause an accident and/or damage the equipment.
- 11) Never operate your Snowblower in poor visibility or without proper lighting conditions.

### ***SAFETY IN OPERATION***

- 1) Be sure there are no obstructions around the equipment and that no one stands near the equipment when in operation.
- 2) Do not operate an engine in a confined or non ventilated area.
- 3) Do not perform any adjustments, cleaning, maintenance or repairs with the engine running. The engine must be stopped and the P.T.O. disengaged. Preferably remove the key from the ignition.
- 4) Wear adequate clothing when working in cold or windy conditions.
- 5) Adjust skid shoes for proper ground clearance of scraper blade, especially in rough terrain or soft ground conditions.
- 6) Before operating, make sure the P.T.O. is properly installed and secured.
- 7) Before starting-up the Snowblower, make sure the auger and drum areas are free of ice.
- 8) Put P.T.O. control in neutral position before starting engine.
- 9) Keep hands, feet and clothing away from moving parts of the Snowblower. Stay away from the discharge chute.

---

---

## ***SAFETY (cont'd)***

---

- 10) Before unplugging the chute, always disengage the P.T.O., stop the engine and relieve all hydraulic pressures.
- 11) Do not operate in excessive inclined conditions. Be careful when turning in slopes.
- 12) Never operate your Snowblower with missing guards or without protective devices in place.
- 13) Do not operate your Snowblower near buildings, windows or other vehicles without prior and proper adjustment of the chute deflector.
- 14) Never aim discharge chute towards people or animals. This may cause serious injuries.
- 15) Always reduce operating speed in slippery conditions.
- 16) Be careful when backing-up, make sure you have good visibility.
- 17) Always be on the lookout for objects which may enter the snowblower.
- 18) If undue vibrations are felt, disengage the P.T.O., stop the motor and look for the cause of the vibration. Vibration is usually the indication of a problem.
- 19) At the end of the operation, disengage the P.T.O., lower the Snowblower, put transmission in neutral, apply parking brake, stop engine and remove the key from the ignition.

### ***SAFETY WITH MAINTENANCE***

- 1) Perform the Snowblower maintenance according to recommendations contained in this manual.

- 2) Stop engine and relieve all hydraulic pressures before doing inspection, maintenance or repairs.
- 3) Never perform any work under the Snowblower while it is supported only by the tractor's hydraulic system. It must be completely supported by wooden blocks or other safe means.

### ***SAFETY IN TRANSPORT***

- 1) On public roads, use proper safety lights and check local regulations.
- 2) Be alert while driving on the road. Never carry passengers.
- 3) Always disengage P.T.O. while moving from one area of work to another.
- 4) It is recommended to use both brake pedals simultaneously for better control.
- 5) The recommended road speed should be such as to maintain full control over steering and braking.
- 6) Be careful while backing up, make sure you have good visibility.

### ***SAFETY IN STORAGE***

- 1) Provide adequate supports to prevent any accidental overturning of the Snowblower.
- 2) Do not let children play in the area where the Snowblower is stored.

**2**

# DECALS

## SAFETY DECALS

The safety decals are affixed wherever special safety precautions are indicated. Locate them on the machine and read them carefully. If a decal is damaged, lost or illegible, install a new one. The following photos indicate where each one must be installed.

3

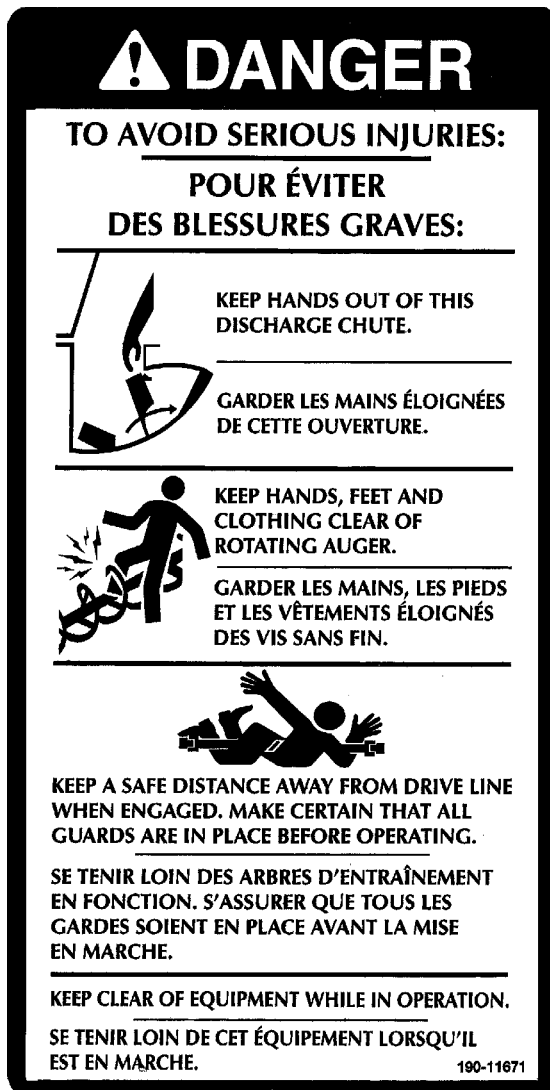

Figure 3  
Decal A

Part no.: 190-11671



Figure 3

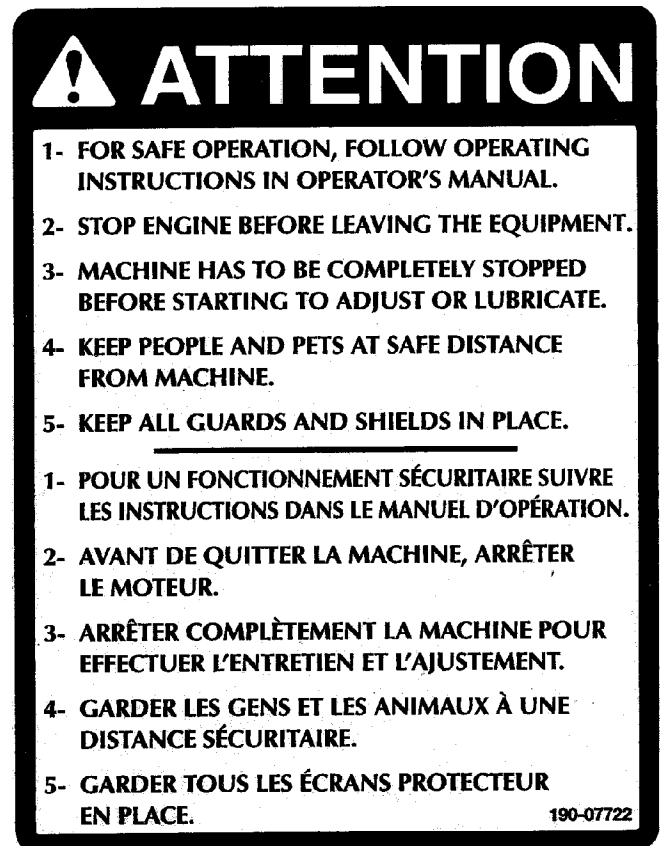

Figure 4  
Decal B

Part no.: 190-07722



## DECALS (cont'd)

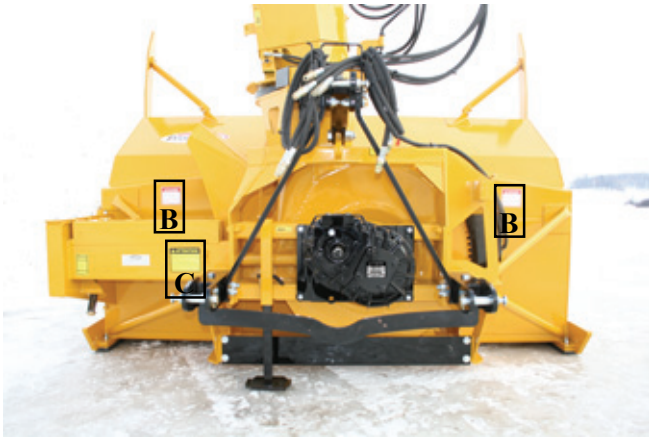

Figure 5  
Decal B

Part no.: A112



Figure 6  
Decal D

Part no.: A103

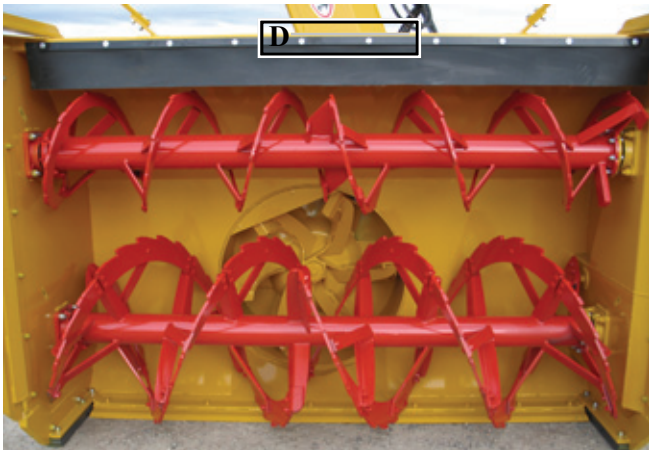

Figure 8

Decal E in Fig. 9 is located directly on the P.T.O. shaft. It is not visible when the safety shield is in place. It must never be visible when you operate the equipment.



Figure 9  
Decal E

Part no.: A108

3

# DECALS (cont'd)

3

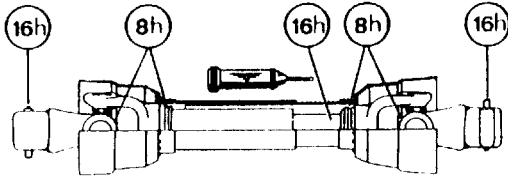

Figure 10  
Decal **D**

Part no.: A 109

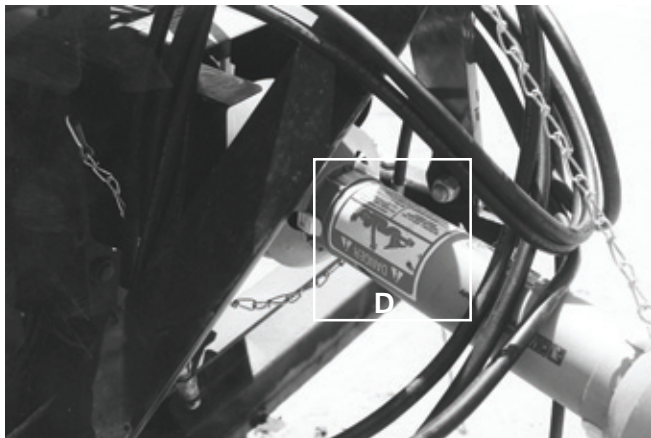

Figure 11

## MAINTENANCE DECALS

The maintenance decals indicate the points requiring lubrication. Refer to maintenance section for more details.

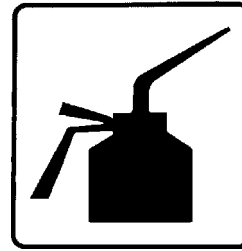

Figure 12

Part no.: A 105



Figure 13

Part no.: A 106



Figure 14  
Decal **E**

Part no.: 190-13701



Figure 15

## DECALS (cont'd)



Figure 16



Figure 17  
Decal F

Part no.: 190-11581



Figure 18



Figure 19  
Decal G

Part no.: 190-10991



Figure 20

---

---

## DECALS (cont'd)

---

3

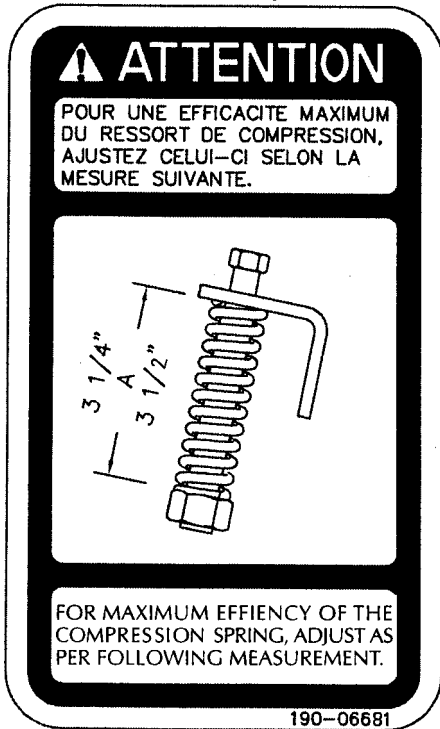

Figure 21  
Decal H

Pièce no.: 190-06681



Figure 22

---

# ASSEMBLY

---



Figure 23

## ASSEMBLY

- 1) The Snowblower is shipped partly assembled.
- 2) The reduction gearbox can be rotated to optimize the P.T.O. shaft working angle (Fig. 23). To rotate, completely remove the support plate and the reduction gearbox. Place the reduction gearbox on the support plate in the required position and then reinstall the assembly on the blower. Take care to properly align the reduction gearbox on the shaft of the snowblower's gearbox. If needed, use shims in the support plate corners to eliminate any tension on the shaft.
- 3) Install P.T.O. shaft and place the shear pin end on the Snowblower side. Then attach safety shield support chain as shown (Fig. 24). **WARNING:** The telescoping tubes of the drive shaft must never be allowed to bottom out while maintaining a minimum overlap of 6 inches.

4



Figure 24



Figure 25

---

# STARTING-UP

---

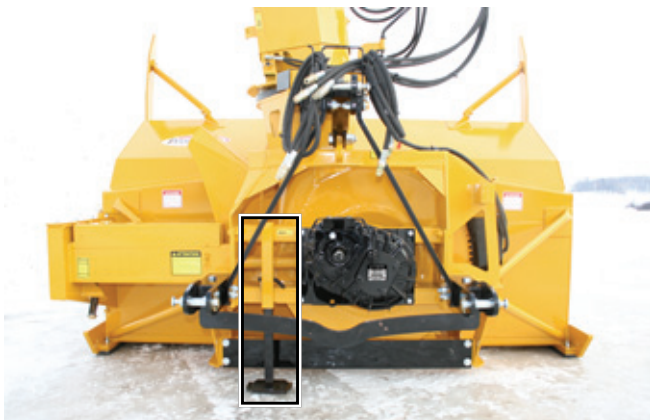

Figure 26

5



Figure 27



Figure 28

## START-UP PROCEDURES

- 1) Check oil level in **gearbox** and in **speed reducer**. Adjust to required oil level as per drawing in Parts List section. Use semi-synthetic **Mobil SHC 320** or equivalent.
- 2) Lubricate all points with a good quality multipurpose grease.
- 3) Check chain take-up adjustment. The spring maintaining the tension must be compressed to a length between 3 1/4" and 3 1/2".
- 4) Verify for adequate tightness of all fastening devices. Refer to torque chart on page 35.
- 5) Adjust skid shoes according to ground conditions. Use shims # 130-63351. (Fig. 25).
- 6) Following the installation of the Snowblower on the tractor, **do not forget** to lift the storage support (Fig. 26).
- 7) Use 1000 RPM drive line, your snowblower is equipped with a 1000 to 540 RPM speed reducer.
- 8) Check oil level in **auger drive chain box**. Fill to level of plug (Fig. 27). Use **SAE 80W90** oil.
- 9) Check impeller adjustment. The tip of the blades should be approximately 1/8" to 3/16" from the discharge wall of the drum. If necessary, adjust with the take-up screws provided (Fig. 28).
- 10) In order to avoid damaging your snowblower, adjust the speed of descent of your 3 point hitch to prevent striking the ground too hard.
- 11) Adjust the hydraulic flow in order to have a good control of the rotation speed of the chute.

---

# MAINTENANCE

---

- 1) Wipe off all grease fittings with a clean cloth before adding grease in order to avoid injecting dirt and sand.
- 2) Repair or replace damaged grease fittings.
- 3) Lubricate all grease fittings every 10 hours of operation.
- 4) Lubricate P.T.O. shaft as indicated below:

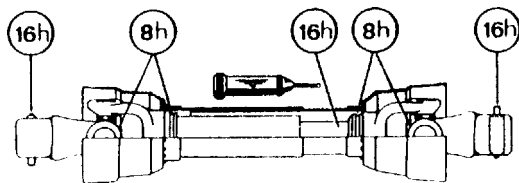

Pull out the P.T.O. And lubricate between the two tubes **with low temperature grease**.

- 5) **Check** oil level in **gear box** once a month. Adjust to required oil level as per drawing page 32. Use semi-synthetic **Mobil SHC 320** or equivalent.
- 6) **Check** oil level in **speed reducer** once a month. Adjust to required oil level as per drawing page 29. Use semi-synthetic **Mobil SHC 320** or equivalent.
- 7) **Check** oil level in **auger drive chain box** once a month. Fill to level plug, figure 27 page 14. Use **SAE 80W90** oil.
- 8) Check tension of drive chain every 24 hours of operation and adjust if necessary.
- 9) Check for tightness of bearing collars every 48 hours of operation.
- 10) Change **gear box** oil once a year. Adjust to required oil level as per drawing page 32. Use semi-synthetic **Mobil SHC 320** or equivalent.
- 11) Change the **speed reducer** oil once a year. Adjust to required oil level as per drawing page 29. Use semi-synthetic **Mobil SHC 320** or equivalent.
- 12) Change the **auger drive chain box** oil once a year. Fill to level plug, figure 27 page 14. Use **SAE 80W90** oil.
- 13) Check all nuts and bolts once a year. If necessary use torque chart on page 36.
- 14) For the auger drive shaft, always use a grade 5 shear bolt.
- 15) For the PTO shaft, always use a grade 8.8 shear bolt at 1000 RPM.
- 16) UHMW slides do not require lubrication except at the end of the season in order to prevent corrosion of steel components that are in contact with the UHMW material.

---

---

## ***STORAGE***

---

- 1) Store the Snowblower in a cool, dry place.
- 2) Support the Snowblower with wooden blocks.
- 3) Keep all piston rods in the retracted position. This will assure better protection against the elements.
- 4) Clean your Snowblower.
- 5) Thoroughly inspect all parts of the Snowblower. Replace or repair worn or defective parts.
- 6) Touch-up or repaint if necessary.
- 7) Lubricate all points before storage.



# TROUBLESHOOTING

## P.T.O. SHAFT

PROBLEM	POSSIBLE CAUSE	CORRECTION
<ul style="list-style-type: none"> <li>- Premature wear of U-joints and/ or bluish color of cross journals.</li> </ul>	<ul style="list-style-type: none"> <li>- Insufficient lubrication.</li> <li>- Excessive working angle.</li> <li>- Lubricant not adapted for this type of application.</li> </ul>	<ul style="list-style-type: none"> <li>- Follow lubrication recommendations.</li> <li>- Replace defective U-joints.</li> <li>- Make sure the Snowblower inlet face is perpendicular to the ground and if possible readjust 3-point hitch in order to position the Snowblower further away from tractor.</li> <li>- Use an appropriate lubricant.</li> </ul>
<ul style="list-style-type: none"> <li>- Gripping or premature wear of telescoping members.</li> </ul>	<ul style="list-style-type: none"> <li>- Too much sliding under load.</li> <li>- Tube overlap too-short: minimum recommended is 6".</li> <li>- Insufficient lubrication.</li> <li>- Contaminants (sand, etc.).</li> </ul>	<ul style="list-style-type: none"> <li>- Avoid raising Snowblower while in operation.</li> <li>- Readjust 3-point hitch in order to position the Snowblower closer to the tractor.</li> <li>- Follow lubrication recommendations.</li> <li>- Replace defective telescopic members.</li> </ul>
<ul style="list-style-type: none"> <li>- Damaged or jammed locking pin or bolt.</li> </ul>	<ul style="list-style-type: none"> <li>- Pin or orifice contaminated by sand, ice, etc.</li> <li>- Telescoping members too long, exerting pressure on locking device.</li> </ul>	<ul style="list-style-type: none"> <li>- Clean and grease.</li> <li>- Readjust 3-point hitch in order to position the Snowblower further away from tractor or shorten tubes.</li> </ul>
<ul style="list-style-type: none"> <li>- Premature wear of guard tube bearing ring.</li> </ul>	<ul style="list-style-type: none"> <li>- Lack of lubrication.</li> <li>- Wrong installation of guard chain.</li> <li>- Part of the guard in contact with the equipment.</li> </ul>	<ul style="list-style-type: none"> <li>- Follow lubrication instructions.</li> <li>- Adjust chain to prevent interference between guard &amp; equipment.</li> <li>- Replace worn or damaged bearing rings.</li> </ul>
<ul style="list-style-type: none"> <li>- Cut or deformed safety guard tubes.</li> </ul>	<ul style="list-style-type: none"> <li>- Tubes in contact with the equipment.</li> </ul>	<ul style="list-style-type: none"> <li>- Eliminate any interference between tubes and equipment or tractor.</li> <li>- Replace damaged tubes.</li> </ul>

# ***TROUBLESHOOTING (cont'd)***

## ***SNOWBLOWER***

<b>PROBLEM</b>	<b>POSSIBLE CAUSE</b>	<b>CORRECTION</b>
- The snow is not being thrown as far as usual.	<ul style="list-style-type: none"> <li>- Tractor RPM too low.</li> <li>- Gap too wide between impeller blade tip and drum outlet wall.</li> <li>- Insufficient tractor HP.</li> </ul>	<ul style="list-style-type: none"> <li>- Raise P.T.O. speed to a minimum of 540 RPM.</li> <li>- Adjust impeller blades closer to drum outlet (1/8" to 3/16").</li> <li>- Reduce travel speed.</li> </ul>
- Frequent plugging of discharge chute.	<ul style="list-style-type: none"> <li>- Tractor RPM too low.</li> <li>- Tractor RPM reduced too early with snow still in the Snowblower.</li> <li>- Slippage of PTO clutch mechanism.</li> <li>- Wet snow condition.</li> </ul>	<ul style="list-style-type: none"> <li>- Raise P.T.O. speed to a minimum of 540 RPM.</li> <li>- Make sure the Snowblower is completely empty before reducing RPM, especially on tractors with foot controlled RPM.</li> <li>- Repare clutch.</li> <li>- Reduce travel speed.</li> <li>- Remove the chute access panel.</li> </ul>
- The impeller will not turn.	<ul style="list-style-type: none"> <li>- Shear bolt broken on drive shaft.</li> </ul>	<ul style="list-style-type: none"> <li>- Replace shear bolt.</li> </ul>
- The auger will not turn.	<ul style="list-style-type: none"> <li>- Shear bolt broken on drive shaft.</li> <li>- Shear bolt broken on auger drive shaft.</li> <li>- Broken drive chain.</li> </ul>	<ul style="list-style-type: none"> <li>- Replace shear bolt.</li> <li>- Replace shear bolt.</li> <li>- Fix or replace chain.</li> </ul>
- The rotating drum will not turn.	<ul style="list-style-type: none"> <li>- Ice accumulation.</li> <li>- Wrong hydraulic connections.</li> </ul>	<ul style="list-style-type: none"> <li>- Remove ice.</li> <li>- Check hydraulic connections.</li> </ul>
- Rotating drum will not hold it's position when blowing via the spout.	<ul style="list-style-type: none"> <li>- Cushion valve setting too low.</li> <li>- Tension of the spring in the drum locking mechanism insufficient.</li> </ul>	<ul style="list-style-type: none"> <li>- Reset cushion valve up to 1800 psi (max.)</li> <li>- Increase tension of spring by adding shim(s).</li> </ul>
- The chute will not turn.	<ul style="list-style-type: none"> <li>- Ice accumulation.</li> <li>- Wrong hydraulic connections.</li> </ul>	<ul style="list-style-type: none"> <li>- Remove ice.</li> <li>- Check hydraulic connections.</li> </ul>

# SPECIFICATIONS

Model		PGV-1022TRC-220
Horse power required		175 to 300 HP
Approximative performance		1250 tons imp./hour (tractor 200 HP)
Height with PCTC-IND	working position	156"
Frame height		68" (1727 mm)
Lateral blades height	Standards	78 3/4" (2000 mm)
	Opt. (T1 or hyd.)	96" (2438 mm)
Working width		102" (2591 mm)
Impeller diameter		37" (940 mm)
Depth of drum		15" (381 mm)
Impeller blades		6 replaceable 3/8" (9.5 mm) carbon steel blades
Shear bolt		1 for the impeller + 1 for the auger drive
Size of impeller shaft		2 1/2" (63.5 mm)
P.T.O. speed required		1000 RPM
Impeller speed		540 RPM
Reducer / inverter		<b>Included</b> (250 HP at 1000 RPM) 1000/540 RPM (ratio 1.85 @ 1)
Cooling pump		<b>Option</b> RH250-PGV1022
Upper auger		single band, 20" (508.0 mm) diam. with welded carbon steel tooth
Lower auger		dual band, bolted, 34" (863.6 mm) diam. with welded carbon steel tooth
Auger ball bearing		2 1/2" (63.5 mm) heavy duty cast iron flange
Drive chain		RENOLD No. 100HV in oil bath
Replaceable scraper blade		6" x 1/2" (152 mm x 12.7 mm) carbon steel sharpened
Adjustable skid shoes		Industrial with carbide sole, adjustment with spacers
Lateral skid shoe for sidewalk		Optional with carbide sole
Drum rotation		Hydraulic motor and cushion valve included
Chute rotation		Hydraulic motor and cushion valve included
P.T.O. shaft		V90 (multilobe) 
3-point hitch		Category 2
Frame	Sides	5/16" (7.9 mm) left - 3/8" (9.5 mm)
	Back	3/16" (4.8 mm)
	Drum	Carbon steel 3/8" (9.525mm)
Center of gravity		From the 3-points hitch adjusted at its shortest: 40 9/16" (1030.3 mm)
Weight (with telescopic chute)		5475 lbs (2483.4 kg)

Design and specifications subject to change without notice.

# INDUSTRIAL SNOWBLOWER PGV-1022TRC-220

170-05141

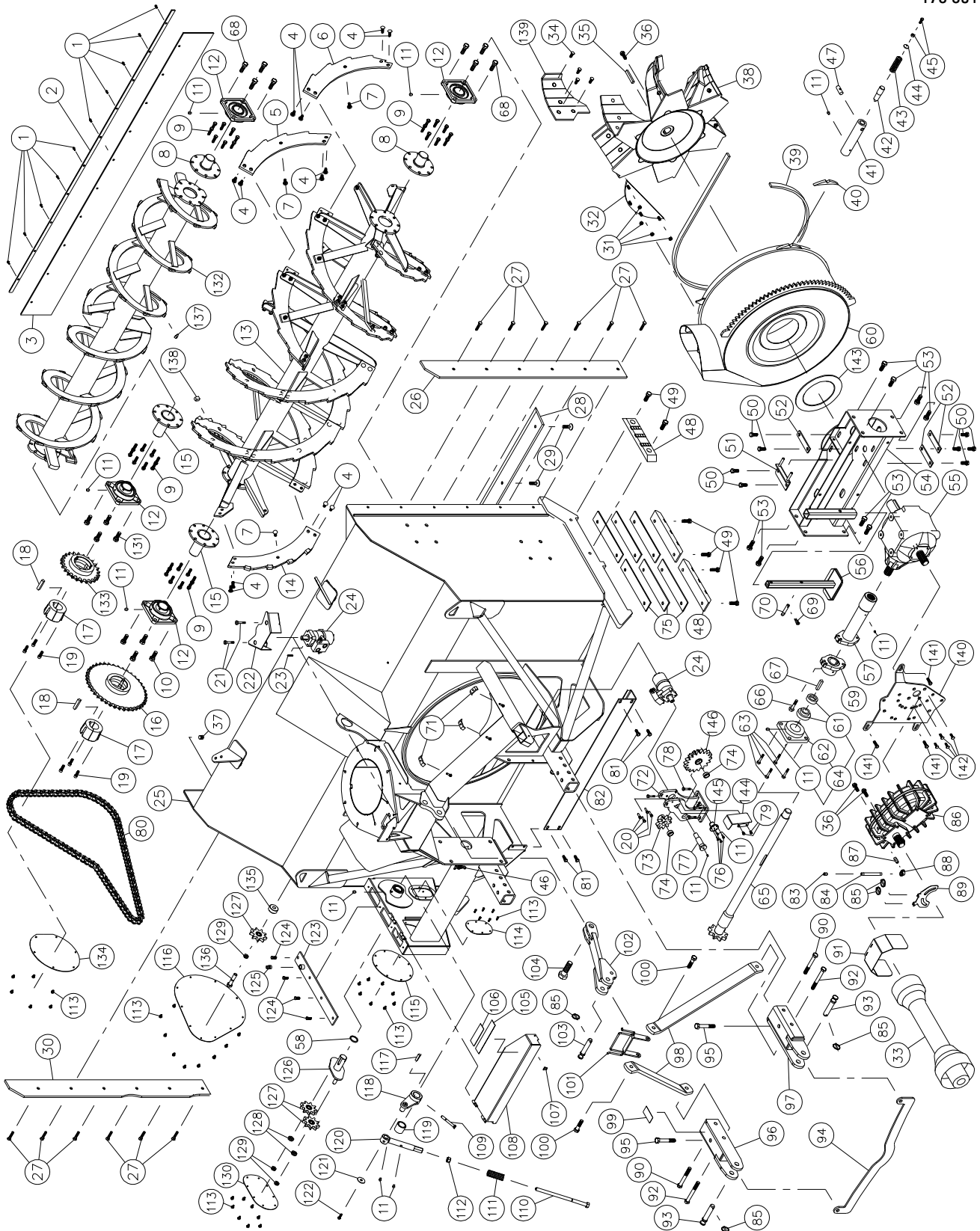

10

# **INDUSTRIAL SNOWBLOWER PGV-1022TRC-220 (cont'd)**

REF.	PART #	DESCRIPTION	QTY
1	300-36280	Bolt 3/8" NC x 1 1/4" lg + nylon locknut .....	10
2	140-23101	Back plate for the shroud .....	1
3	190-11681	Shroud .....	1
4	321-40310	Carriage bolt 1/2" NC x 1 1/2" lg + lock washer + nut .....	76
5	130-45391	Right side ribbon for open flight auger .....	6
6	130-45401	Right end ribbon for open flight auger .....	2
7	321-40325	Carriage bolt 1/2" NC x 1 3/4" lg + lock washer + nut .....	14
8	110-40311	Auger hub (auger-idler end) .....	2
9	300-40325	Bolt 1/2" NC x 1 3/4" lg + lock washer + nut .....	32
10	300-46370	Bolt 3/4" NC x 2 1/2" lg + nylon locknut .....	12
11	Std.	Grease fitting 1/4"-28 straight .....	9
12	UCFD213-40	Bearing 2 1/2" + heavy duty cast iron flange + 1 grease fitting .....	4
13	110-40091	Open flight auger with welded carbon steel teeth (86) .....	1
14	110-45381	Left side ribbon for open flight auger .....	10
15	110-40301	Auger hub (auger-drive end) .....	2
16	110-40191	Sprocket for auger 100A40 x 1T 6.250" + female adaptor "taper-lock" .....	1
17	9715	Male adaptor "taper-lock" .....	2
18	140-23961	Key (sprocket for auger) .....	2
19	318-40310	Allen socket head screw 1/2"NC x 1 1/2" lg .....	6
20	300-36280	Bolt 3/8" NC x 1 1/4" lg + lock washer .....	4
21	300-34280	Bolt 5/16" NC x 1 1/4" lg + nylon locknut .....	2
22	130-14282	Guard .....	1
23	8369	Key for hydraulic motor .....	2
24	MLH-315	Hydraulic motor .....	2
25	120-07211	Frame PGV-1022TRC-220 .....	1
26	130-75231	Right lateral blade .....	1
27	319-40325	Plow bolt 1/2" NC x 1 3/4" lg + nut & lock washer .....	12
28	140-09461	Scraper blade, carbon steel, not reversible, sharpened 5/8" x 6" x 94 7/8" lg .....	1
29	319-40325	Plow bolt 1/2" NC x 1 3/4" lg + nylon locknut .....	10
30	130-19591	Left lateral blade .....	1
31	346-41000	Nylon locknut 1/2" NC thin .....	4
32	110-41311	Deflector .....	1
33	9599	P.T.O. shaft V90 1 3/8"-21 splines .....	your choice
33	9604	P.T.O. shaft V90 1 3/4"-20 splines .....	your choice
34	319-40325	Plow bolt 1/2" NC x 1 3/4" lg + nut & lock washer .....	24
35	140-08551	Key for impeller .....	1
36	300-44310	Bolt 5/8" NC x 1 1/2" lg + lock washer .....	1
37	9749	Magnetic cap 3/8" NPT (disc style) .....	1
38	110-40971	Impeller with bolted blades .....	1
39	190-07951	U-shaped UHMW 3/8" x 7/8" x 119 23/32" lg .....	1
40	130-08441	Stop block for drum lock (welded on drum) .....	1
41	160-03952	Body - drum lock (welded on frame) .....	1
42	150-01542	Latch pin - drum lock .....	1
43	9473	Compression spring .....	1
44	130-08471	Washer .....	1
45	300-38325	Bolt 7/16" NC x 1 3/4" lg (full length thread) + lock nut .....	1
46	8374	Adjustable clamp fastener (welded) .....	1
47	150-02561	Pin .....	1
48	190-10671	Skid shoe with carbide inserts (except lateral skid shoe for sidewalk) .....	4
49	300-44370	Bolt 5/8" NC x 2 1/2" lg + nylon locknut .....	8
50	309-40035	Bolt M16 x 12.0 x 35mm + lock washer 5/8" + 6 flat washers .....	8

# INDUSTRIAL SNOWBLOWER PGV-1022TRC-220 (cont'd)

REF.	PART #	DESCRIPTION	QTY
51	110-41141	Adjustment plate for gear box + 4 nutss 1/2" NC .....	1
52	140-24321	Back plate .....	3
53	300-46340	Bolt 3/4" NC x 2" lg + nylon locknut .....	8
54	110-40871	Gear box support .....	1
55	9714	Gear box T-301 inverted .....	1
56	9462	Storage support .....	1
57	110-43002	Side shaft & shearplate (long side) + splined adaptor (20 splines) .....	1
58	OR-224	O-ring 1/8" X 1 3/4" i.d. X 2" o.d. ....	1
59	110-11362	Side shaft & shearplate (short side) .....	1
60	110-40821	Rotary drum 37" dia. ....	1
61	HC21132	Bearing 2" with eccentric collar .....	1
62	FS211	Flange 4 holes .....	1
63	190-11561	Bolt 5/8" NC x 2" lg (modified) + nylon locknut .....	4
64	HCFS211-32	Bearing 2" + flange + 1 grease fitting .....	1
65	110-43051	Auger drive shaft .....	1
66	300-38355	Bolt 7/16" NC x 2 1/4" lg + nylon locknut .....	1
67	140-08541	Key for auger drive shaft & shearplate (short side) .....	1
68	300-46370	Bolt 3/4" NC x 2 1/2" lg + flat washer & nylon locknut .....	8
69	Std.	Hitch pin clip 5/32" .....	1
70	8220	Storage support pin .....	1
71	140-00481	Hydraulic hoses bracket .....	3
72	110-43341	Drum rotation reducer bracket .....	2
73	110-43362	Sprocket (9 teeth) .....	2
74	16026161	Aluminium bronze bushing 1" i.d. x 1 1/2" o.d. x 5/8" lg .....	1
75	130-63351	Spacer for skid shoes .....	12
76	300-32220	Bolt 1/4" NC x 3/4" lg + lock washer .....	3
77	150-14231	Shaft 1 3/4" dia. for rotation reducer + nylon locknut 1" NC .....	1
78	300-36310	Bolt 3/8" NC 1 1/2" lg + nylon locknut .....	4
79	300-34190	Bolt 5/16" NC x 1/2" lg .....	4
80	190-11691	Chain Renold #100 HV x 156 1/4" (125 links) .....	1
80	59-100HD	Demi-maille d'attache #100 HV .....	1
80	26A100HD	Connecting link #100 HV .....	1
81	300-40280	Bolt 1/2" NC x 1 1/4" lg + nylon locknut + flat washer .....	4
82	130-74041	Guard for ring gear segment .....	1
83	Std.	Vent plug 3/8 NPT + fitting 3/8" x 1/8" .....	1
84	Std.	Pipe 3/8" NPT x 6" lg .....	1
85	Std.	Lynch pin 1/4" x 1 3/4" .....	4
86	9717	Inverter reduction gear box 1000 / 540 .....	1
87	Std.	Pipe 3/8" NPT x 1 1/2" lg .....	1
88	Std.	Elbow 90 degrees 3/8" NPT .....	1
89	130-69871	Support plate for hinged P.T.O. shroud .....	1
90	302-46580	Bolt 3/4" NF x 6" lg + nylon locknut .....	5
91	130-75701	Hinged P.T.O. shroud .....	1
92	302-46610	Bolt 3/4" NF x 6 1/2" lg + nylon locknut .....	2
93	9269	Pin category 2 .....	1
94	130-74261	3-point hitch reinforcement .....	1
95	320-46520	Bolt 3/4" NF x 5" lg + nylon locknut .....	2
96	110-41912	Left lower hitch .....	1
96	110-42862	Left lower hitch category 3 .....	1
97	110-41911	Right lower hitch .....	1
97	110-42861	Right lower hitch category 3 .....	1

# **INDUSTRIAL SNOWBLOWER PGV-1022TRC-220 (cont'd)**

REF.	PART #	DESCRIPTION	QTY
98	140-22721	3-point side bar .....	1
99	190-11531	Non-skidding tape .....	1
100	300-46400	Bolt 3/4" NC x 3" lg + nylon locknut + flat washer .....	2
101	110-15201	Hoses support .....	1
102	110-38801	Upper hitch .....	1
103	150-05961	Pin category 2 (top link) .....	1
104	300-54460	Bolt 1 1/4" NC x 4" lg + nylon locknut .....	1
105	190-11541	Non-skidding tape .....	1
106	190-11551	Non-skidding tape .....	1
107	8375	Hook for adjustable clamp fastener (welded) .....	1
108	110-41021	Auger drive shaft guard .....	1
109	300-40460	Bolt 1/2" NC x 4" lg GR 12 + nylon locknut .....	1
110	110-39191	Threaded rod for idler adjustment .....	1
111	9687	Compression spring .....	1
112	346-46000	Nut 3/4" NC .....	1
113	311-34012	Bolt M10-1.25 x 12 mm lg + flat washer M10 (assembly with loctite 242) .....	38
114	130-75592	Access panel for chain .....	1
115	130-61323	Access panel for auger drive shaft .....	1
116	130-74102	Access panel for auger drive sprocket (lower auger) .....	1
117	140-12161	Idler key .....	1
118	110-39101	Idler (outside part) .....	1
119	160-08421	Aluminium bronze bushing 1 3/4" i.d. x 2 1/4" o.d. x 2" lg .....	1
120	110-17762	Threaded tube for idler adjustment .....	1
121	378-40340	Flat washer 1/2" x 2" .....	1
122	300-40415	Bolt 3/8" NC x 3 1/4" lg .....	1
123	110-38791	Upper chain guard cover .....	1
124	300-38250	Bolt 7/16" NC x 1" lg + lock washer .....	4
125	9619	Vent plug 1/2" NPT .....	1
126	110-35421	Idler (inside part) .....	1
127	9470	Idler sprocket 100A9 H3/4 .....	3
128	160-22371	Spacer .....	2
129	346-47000	Nylon locknut 3/4" NC thin .....	3
130	130-72012	Idler cover .....	1
131	190-11571	Bolt 3/4" NC x 2 1/2" lg + nylon locknut (modified) .....	4
132	110-40961	Upper auger with carbon steel tooth .....	1
133	110-13322	Sprocket for auger 100A24 x 1T 6.250" + female adaptor "taper-lock" .....	1
134	130-73802	Access panel for auger drive sprocket ( upper auger ) .....	1
135	150-13381	Spacer .....	1
136	300-46430	Bolt 3/4" NC x 3 1/2" lg + nylon locknut .....	1
137	130-74361	Tooth (welded on the upper auger) .....	48
138	130-13861	Tooth (welded on the lower auger) .....	86
139	130-73891	Impeller blade .....	6
140	130-74231	Mounting plate for reduction gearbox .....	1
141	300-40310	Bolt 1/2" NC x 1 1/2" lg + nylon locknut + flat washer .....	3
142	331-34025	Bolt M10-1.5 x 20mm lg .....	4
143	130-14641	UHMW flat washer 3/16" x 10" i.d. x 14" o.d. ....	1
144	130-79211	Drum rotation guard .....	1
145	150-14241	Gear support - shaft 2" dia. ....	1
146	110-43371	Drive gear 18 teeth for drum rotation reducer .....	1

# INDUSTRIAL CHUTE PCTC-IND

170-04901R1

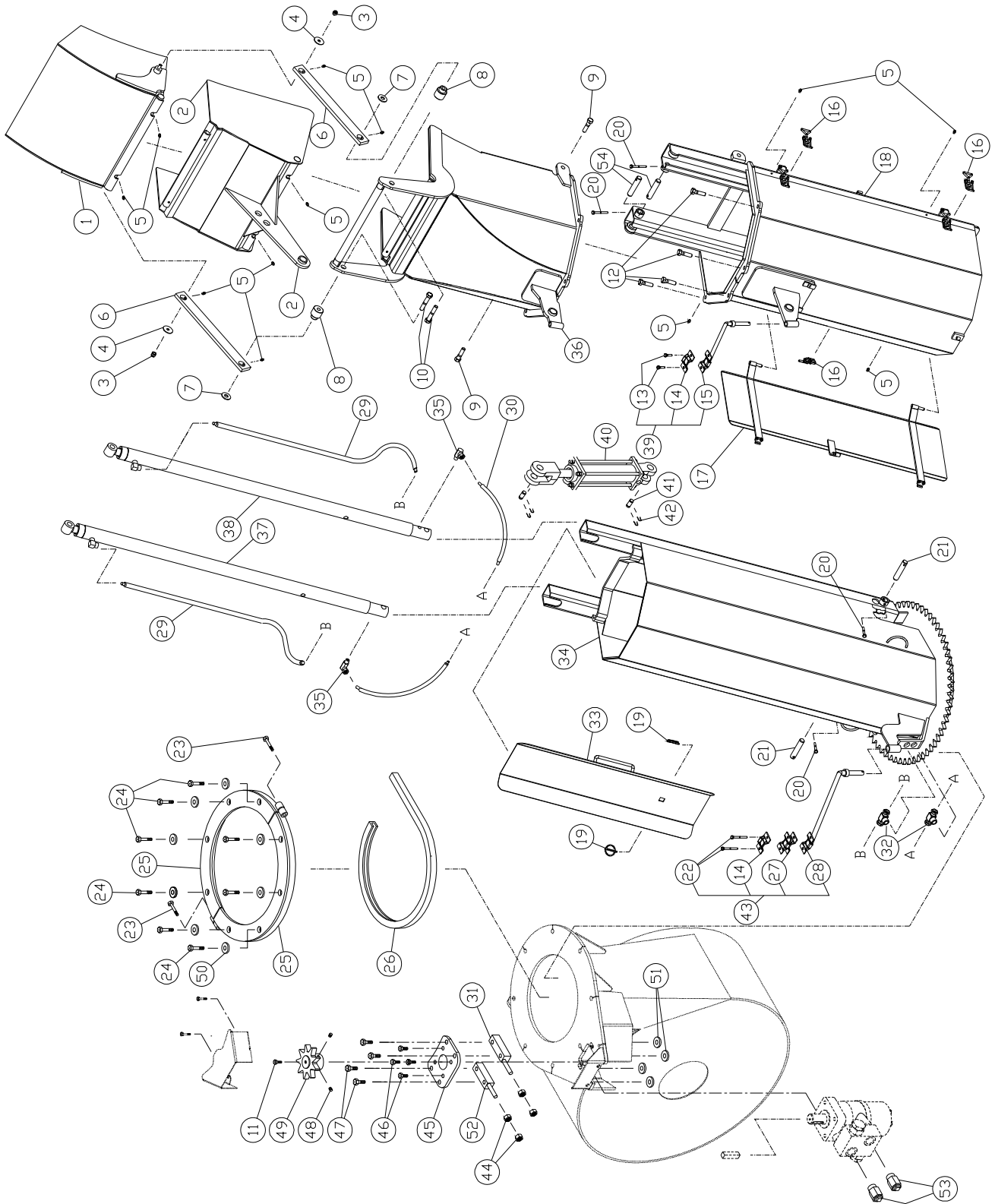



# INDUSTRIAL CHUTE PCTC-IND

REF.	PART #	DESCRIPTION	QTY
1	110-13464	Upper deflector .....	1
2	110-39161	Lower deflector .....	1
3	346-36000	Nylon locknut 3/8" .....	2
4	378-36500	Washer 3/8" i.d. x 1 1/2" o.d. ....	2
5	Std.	Grease fitting 1/4"-28 straight .....	12
6	140-22871	Connecting rod .....	2
7	378-37500	Washer 1/2" i.d. x 1 3/8" o.d. ....	2
8	150-05311	Spacer for connecting rod .....	2
9	300-40340	Bolt 1/2" NC x 2" lg + nylon locknut .....	2
10	300-40380	Bolt 1/2" NC x 2 3/4" lg + nylon locknut .....	2
11	300-32220	Bolt 1/4" NC x 3/4" lg + lock washer .....	1
12	300-40325	Bolt 1/2" NC x 1 3/4" lg + nylon locknut .....	4
13	300-32250	Bolt 1/4" NC x 1" lg + nylon locknut .....	2
14	140-13071	Hoses support plate .....	2
15	110-01122	Mounting support late for upper extension .....	1
16	8373	Adjustable clamp fastener (welded) .....	3
17	110-29391	Acces panel for upper extension .....	1
18	110-39152	Upper extension .....	1
19	Std.	Lynch pin 3/16" x 1 1/4" .....	2
20	300-32325	Bolt 1/4" NC x 1 3/4" lg + nylon locknut .....	4
21	150-12701	Clevis pin for cylinder .....	2
22	300-32370	Bolt 1/4" NC x 2 1/2" lg + nylon locknut .....	2
23	300-38400	Bolt 7/16" NC x 3" lg + nylon locknut .....	2
24	300-40415	Bolt 1/2" NC x 31 /4" lg + nylon locknut .....	8
25	110-12351	Retaining bracket .....	2
26	190-03381	U-shaped UHMW + - 16" i.d. ....	1
27	110-20611	Hoses mounting plate .....	1
28	110-04982	Hoses support on lower extension .....	1
29	190-08231	Hose 1/4" SAE 100R2AT - 500 PSI x 63 1/2" lg .....	2
30	190-08241	Hose 1/4" SAE 100R2AT - 500 PSI x 20 1/2" lg .....	2
31	110-38321	Spacer .....	1
32	9456-06-06	Adaptor T female 3/8" NPT swivel, female 3/8" NPT .....	2
33	110-26671	Acces panel for lower extension .....	1
34	110-39001	Lower extension .....	1
35	9406-04-04	Elbow 90 degrees 1/4" NPT swivel .....	2
36	110-41591	Hexagonal extension .....	1
37	15 PC 32G	Cylinder 1 1/2" x 32" stroke .....	1
38	15 PC 32D	Cylinder 1 1/2" x 32" stroke .....	1
39	TSB-74104	Hoses support for deflector cylinder .....	1
40	25TR08	Cylinder 2 1/2" x 8" stroke .....	1
41	6004	Clevis pin 1" x 3 1/8" lg (2) .....	1
42	Std.	Hairpin cotter 7/8" (4) .....	1
43	TSB-74104-IND	Hoses support on chute base .....	1
44	336-38000	Nut 7/16" NC .....	4
45	130-08152	Orbit motor support .....	1
46	300-36250	Bolt 3/8" NC x 1" lg + lock washer .....	4
47	300-38385	Bolt 7/16" NC x 2 3/4" lg + nylon locknut .....	4
48	323-36160	Hexagonal socket set screw 3/8" NC x 3/8" lg .....	2
49	110-36731	Carbon steel sprocket 9 teeth .....	1
50	150-12731	Flat washer .....	16
51	150-12741	Flat washer .....	4
52	110-38322	Spacer .....	1
53	110-40071	Restrictor .....	2
54	150-13181	Clevis pin for cylinder .....	2

# HYDRAULIC TELESCOPIC CHUTE PCTC-INDR

170-05401

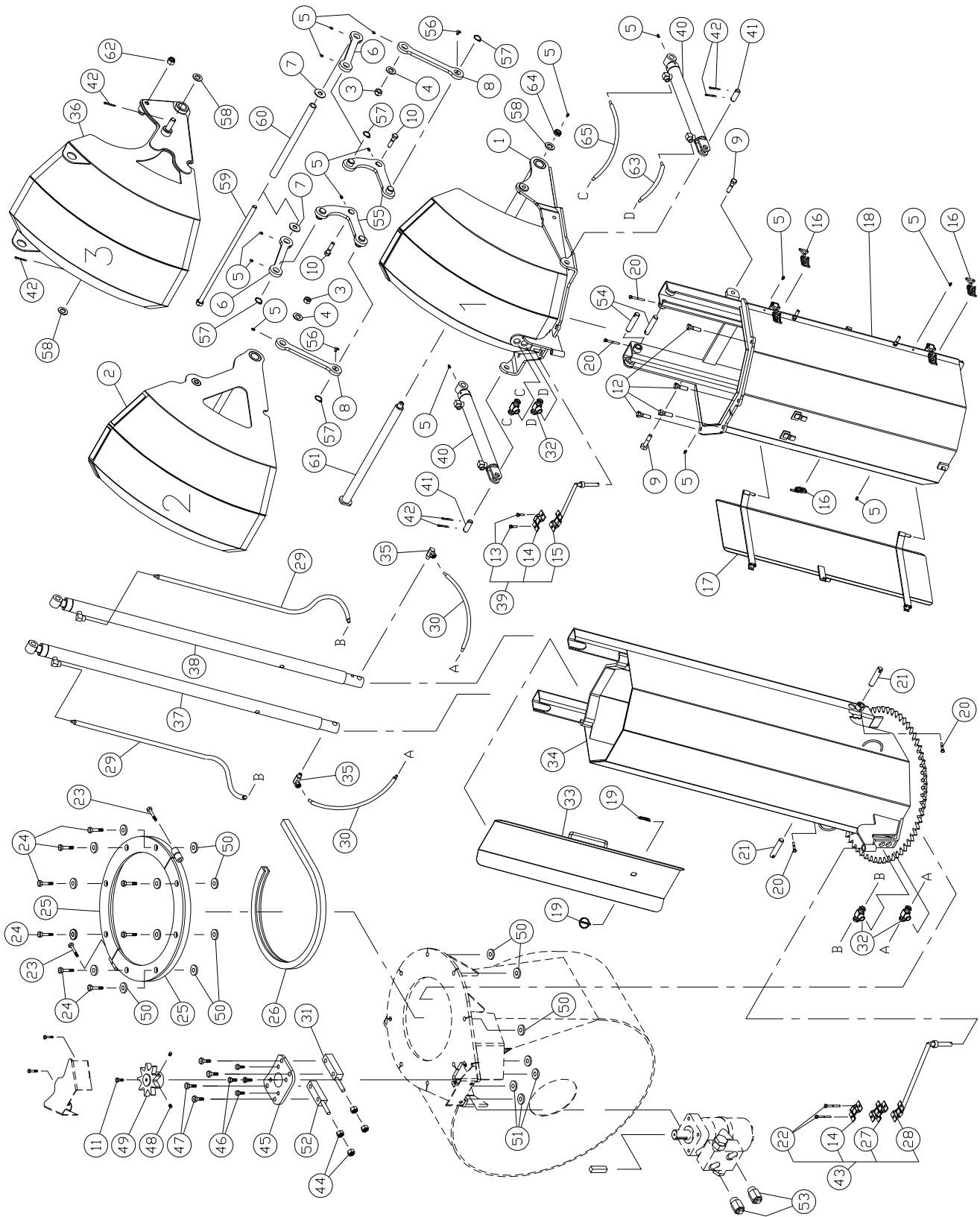

10

# HYDRAULIC TELESCOPIC CHUTE PCTC-INDR (cont'd)

REF.	PART #	DESCRIPTION	QTY
1	110-43233	Stationary deflector .....	1
2	110-43203	Intermediate deflector .....	1
3	346-36000	Nylon locknut 3/8" .....	2
4	378-36500	Flat washer 3/8" i.d. x 1 1/2" o.d. ....	2
5	Std.	Grease fitting 1/4"-28 straight .....	15
6	130-84931	Lever for terminal deflector .....	2
7	376-43000	Flat washer 5/8" i.d. x 1 1/2" o.d. ....	2
8	130-84942	Lever for intermediate deflector .....	2
9	300-40340	Bolt 1/2" NC x 2" lg + nylon locknut .....	2
10	300-40380	Bolt 1/2" NC x 2" lg + flat washer + nylon locknut .....	2
11	300-32220	Bolt 1/4" NC x 3/4" lg + lockwasher .....	1
12	300-40325	Bolt 1/2" NC x 1 3/4" lg + nylon locknut .....	4
13	300-32250	Bolt 1/4" NC x 1" lg + nylon locknut .....	2
14	140-13071	Hoses mounting plate .....	2
15	110-01122	Mounting support plate for upper extension .....	1
16	8376	Adjustable clamp fastener .....	3
17	110-29391	Access panel for upper extension .....	1
18	110-39152	Upper extension .....	1
19	Std.	Lynch pin 3/16" x 1 1/4" .....	2
20	300-32325	Bolt 1/4" NC x 1 3/4" lg + nylon locknut .....	4
21	150-12701	Clevis pin .....	2
22	300-32370	Bolt 1/4" NC x 2 1/2" lg + nylon locknut .....	2
23	300-38400	Bolt 7/16" NC x 3" lg + nylon locknut .....	2
24	300-40415	Bolt 1/2" NC x 3 1/4" lg + nylon locknut .....	8
25	110-12351	Retaining bracket .....	2
26	190-03381	U-shaped UHMW + - 16" i.d. ....	1
27	110-20611	Hoses mounting plate .....	1
28	110-04982	Mounting support plate for lower extension .....	1
29	190-08231	Hose 1/4" x 67 1/4" lg + 1 fitting 4U104 + 1 4U106 .....	2
30	190-08241	Hose 1/4" x 24 1/4" lg + 1 fitting 4U104 + 1 4U106 .....	2
31	110-38321	Spacer .....	1
32	9456-06-06	«T» female 3/8" NPT swivel , female 3/8" NPT .....	4
33	110-26671	Access door for lower extension .....	1
34	110-39001	Lower extension .....	1
35	9406-04-04	Elbow 90 degress 1/4" NPT swivel .....	2
36	110-43193	Terminal deflector .....	1
37	15PC32G	Cylinder 1 1/2" x 32" stroke .....	1
38	15PC32D	Cylinder 1 1/2" x 32" stroke .....	1
39	TSB-4864	Hoses support for deflector cylinder .....	1
40	15L12	Cylinder 1 1/2" x 12" stroke .....	2
41	150-14101	Clevis pin 3/4" x 2 1/8" lg .....	2
42	Std.	Cotter pin 3/16" x 1 1/4" .....	6
43	TSB-74104-IND	Hoses support on chute base .....	1
44	336-38000	Nut 7/16" NC .....	4
45	130-08152	"Orbit" motor support .....	1
46	300-36250	Bolt 3/8" NC x 1" lg + lock washer .....	4
47	300-38385	Bolt 7/16" NC x 2 3/4" lg + nylon locknut .....	4
48	323-36160	Hexagonal socket set screw 3/8" NC x 3/8" lg .....	2
49	110-44331	Sprocket 9 tooth .....	1
50	150-12731	Flat washer 1/2" heavy duty .....	16
51	150-12741	Flat washer 7/16" heavy duty .....	4
52	110-38322	Spacer .....	1
53	RSP-1/16x10 ORB	Kit of two unidirectional restrictors .....	1
54	150-13181	Clevis pin .....	2
55	110-45643	Central lever pivot .....	2
56	std.	Grease fitting elbow 90 degrees 1/4-28 .....	2

# LATERAL BLADES

170-05301

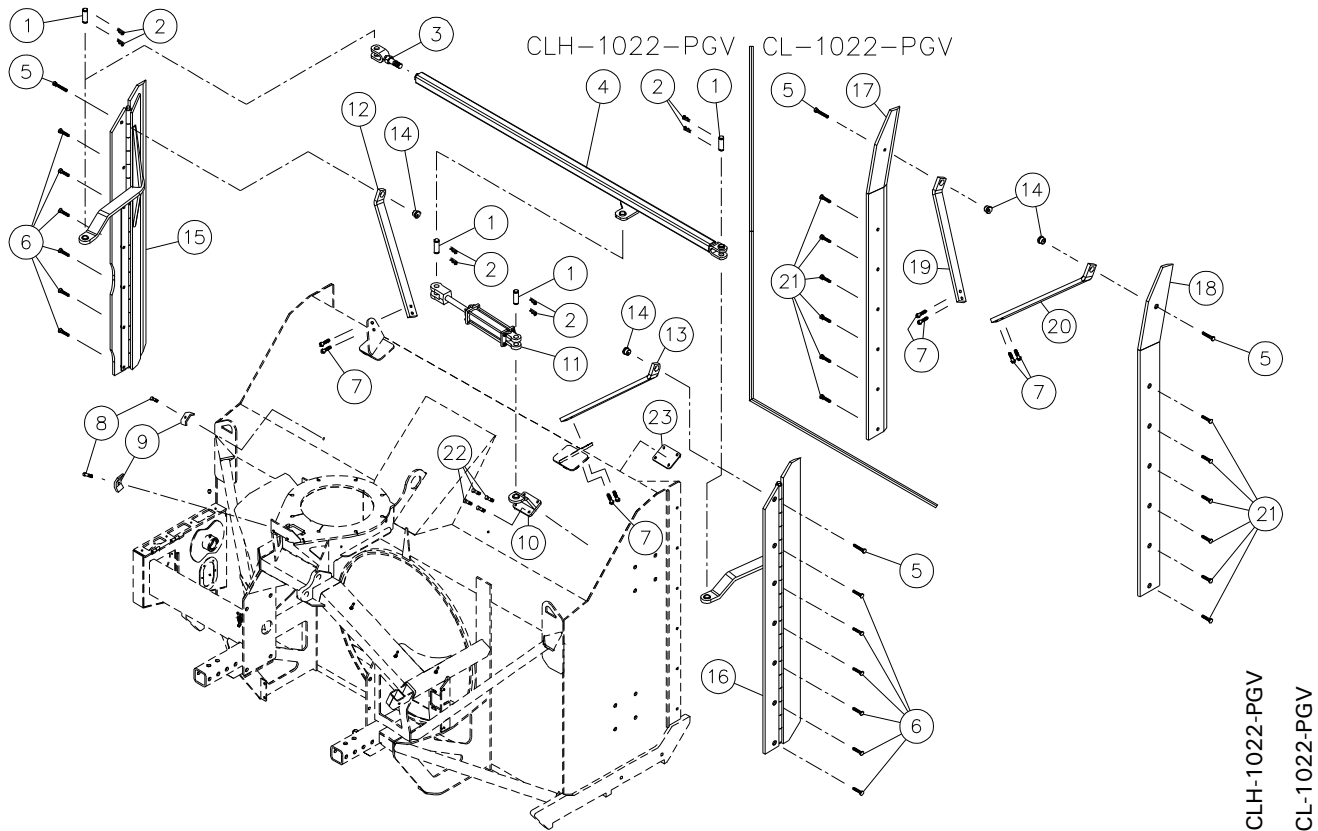

CLH-1022-PGV  
CL-1022-PGV

REF.	PART #	DESCRIPTION	QTY
1	190-11271	Pin for cylinder 1" x 3 1/8" lg	4 -
2	Std.	Hairpin 5/32" x 1 1/2"	8 -
3	110-14121	Adjustable yoke + nut 1"-14 NF	1 -
4	110-41131	Connecting tube	1 -
5	319-40370	Plow bolt 1/2" NC x 2 1/2" lg + nut & lock washer	2 2
6	319-40325	Plow bolt 1/2" NC x 2" lg + nut & lock washer	12 -
7	300-40355	Bolt 1/2" NC x 2 1/4" lg + nylon locknut + flat washer	4 4
8	300-34310	Bolt 5/16" NC x 1 1/2"	2 -
9	140-00481	Hose clamp	2 -
10	110-41121	Cylinder support (stationary part)	1 -
11	25TR08	Cylinder 2 1/2" x 8" stroke	1 -
12	140-24121	Left lateral blade strengthener	1 -
13	140-24122	Right lateral blade strengthener	1 -
14	150-12621	Eccentric positionner	2 2
15	110-42292	Hydraulic lateral blade (carbon steel, left side, sharpened)	1 -
16	110-42291	Hydraulic lateral blade (carbon steel, right side, sharpened)	1 -
17	110-42322	Lateral blade (carbon steel, left side)	- 1
18	110-42321	Lateral blade (carbon steel, right side)	- 1
19	140-24591	Left lateral blade strengthener	- 1
20	140-24592	Right lateral blade strengthener	- 1
21	319-40325	Plow bolt 1/2" NC x 1 3/4" lg + nut & lock washer	- 12
22	300-40325	Bolt 1/2" NC x 1 3/4" lg + nylon locknut + flat washer	4 -
23	130-76591	Interior reinforcing plate	1 -

10

# REDUCTION GEAR BOX # 9717 - 250 HP *(inverter)*

170-05231b.tif

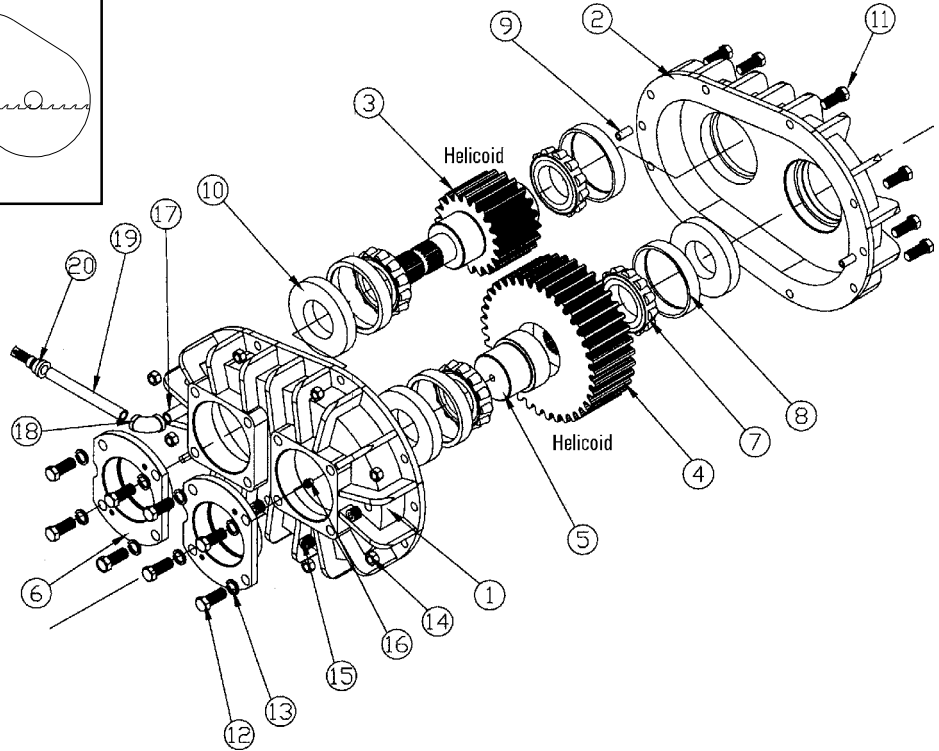
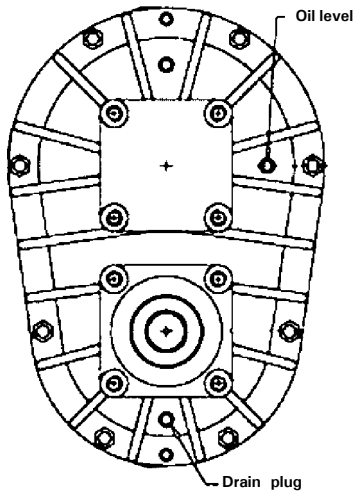
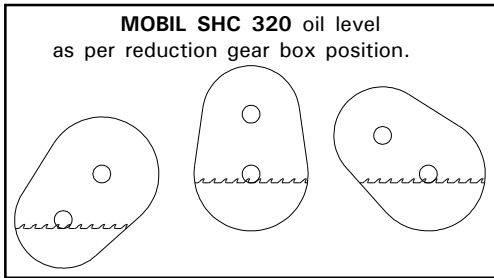

REF.	PART #	DESCRIPTION	QTY
1	9723	Half casing .....	1
2	9724	Half casing .....	1
3	9725	Helioid gear (20 teeth) .....	1
4	9726	Helioid gear (37 teeth) .....	1
5	9727	Adaptor .....	1
6	9728	Open cover .....	2
7	9701	Taper roller bearing: cone JLM714149 .....	4
8	9702	Taper roller bearing: cup JLM714110 .....	4
9	9705	Dowell pin .....	2
10	9704	Oil seal 75 mm x 100 mm x 10 mm .....	3
11	9731	Hexagonal bolt .....	8
12	9732	Hexagonal bolt .....	8
13	9733	Lock washer .....	8
14	9734	Lock nut .....	8
15	9706	Plug 3/8" NPT .....	3
16	9736	Grease fitting .....	1
17	9737	Pipe 3/8" x 1.5" .....	1
18	9738	Elbow 3/8" .....	1
19	9739	Pipe 3/8" x 6" .....	1
20	9740	Vent plug 3/8 NPT + fitting 3/8" x 1/8" .....	1

# OIL COOLER # RH250-PGV1022

170-05361

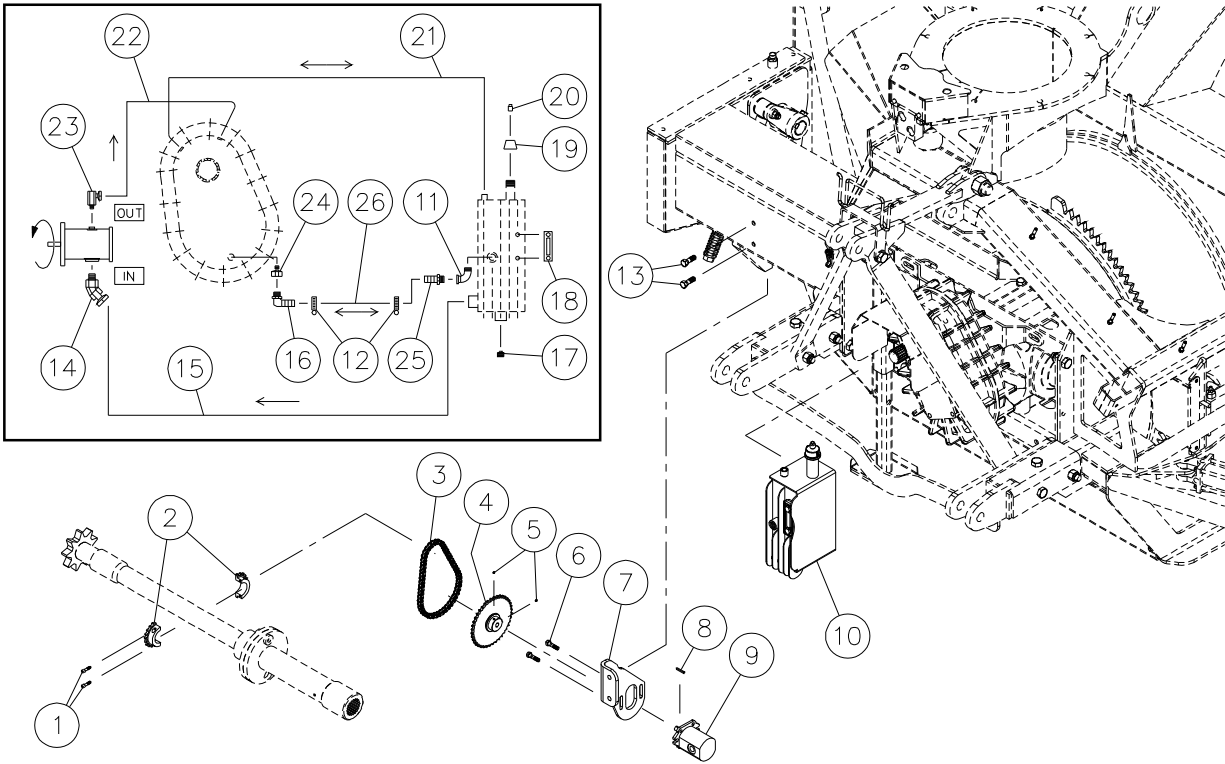

REF.	PART #	DESCRIPTION	QTY
1	318-32260	Hexagonal socket cap screw 1/4" NC x 1" NC .....	2
2	190-11631	Pinion sectionné 40B20 .....	1
3	190-11891	Chain #40 x 27" lg (54 links) .....	1
3	26A40-HC	Connecting link # 40 .....	1
4	110-41901	Sprocket assembly 40A40 .....	1
5	323-32160	Set screw 1/4"-20 NC x 3/8" lg .....	2
6	300-36310	Bolt 3/8" NC x 1 1/2" lg + nylon nut & flat washer .....	2
7	130-75821	Pump mounting plate .....	1
8	140-24811	Key 1/8" x 1" .....	1
9	9750	Hydraulic pump .....	1
10	110-42101	Oil tank assembly .....	1
11	Std.	Elbow 90° 1/2" NPT male - female .....	1
12	Std.	Hose clamp 1 1/2" dia. ....	2
13	300-40310	Bolt 1/2" NC x 1 1/2" lg + nylon locknut .....	2
14	9365-08-08	Fitting 45° .....	1
15	190-11921	Hose 1/2" R1 x 20" lg + 2 fittings 8U108 .....	1
16	110-42871	Elbow 90° 1/2" NPT male x 3/4" Ø hose .....	1
17	9748	Magnetic plug 1/2" .....	1
18	Std.	Thermometer and level .....	1
19	190-11301	Tank cap .....	1
20	Std.	Breather 3/8" NPT .....	1
21	190-11851	Hose 3/8" R1 x 30 1/2" lg + 2 fittings 6U106 .....	1
22	190-11861	Hose 3/8" R1 x 61 1/2" lg + 2 fittings 6U106 .....	1
23	9515-06-06	Fitting 90° .....	1
24	9205-08-06	Fitting female NPSM swivel .....	1
25	9747	Fitting straight 3/4" hose - 1/2 NPTM .....	1
26	190-11881	Hose 3/4" R1 x 17 1/2" lg .....	1

10

# P.T.O. SHAFT # 9599 & 9604 (V90)

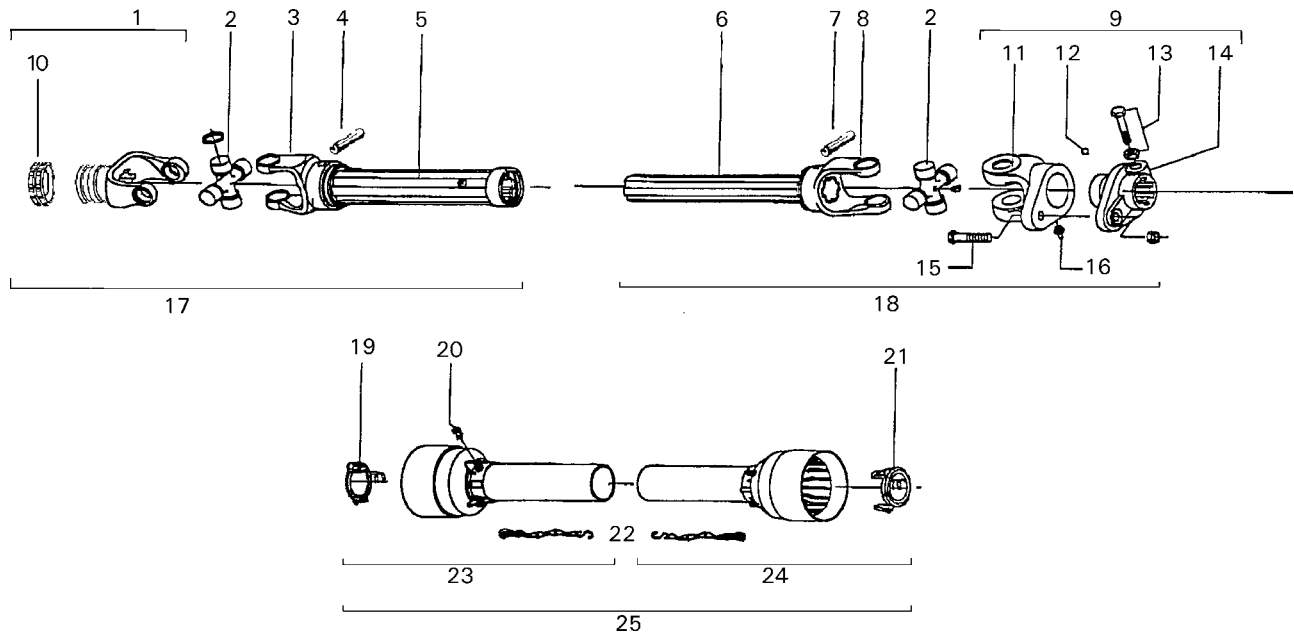

REF.	PART #	DESCRIPTION	QTY
			9599 - 9604
1	9482	Yoke with hole 1 3/8" - 21 splines with slide collar .....	1
1	9483	Yoke with hole 1 3/4" - 20 splines with slide collar .....	- 1
2	9477	U-joint .....	2 2
3	9600	Yoke for outer tube .....	1 1
4	9210	Stopper for tube .....	1 1
5	9601	Outer tube .....	1 1
6	9602	Inner tube .....	1 1
7	9210	Stopper for tube .....	1 1
8	9603	Yoke for inner tube .....	1 1
9	9476	Safety shear yoke .....	1 1
10	8363	Collar kit .....	1 -
10	8364	Collar kit .....	- 1
11	9487	Yoke and shearplate .....	1 1
12	9205	Ball 5/16" dia. ....	24 24
13	9662	Bolt M16x80mm + lock nut .....	2 2
14	9486	Adaptor .....	1 1
15	9207	Bolt M12x65mm grade 10.9 + lock nut .....	1 1
16	8071	Grease fitting .....	1 1
17	9607-1	P.T.O. section, outer part, with protector, 1 3/8" - 21 splines .....	1 -
17	9607-2	P.T.O. section, outer part, with protector, 1 3/4" - 20 splines .....	- 1
18	9608	P.T.O. section, inner part, with protector .....	1 1
19	9460	Bearing ring .....	1 1
20	8109	Stopper .....	6 6
21	9459	Bearing ring .....	1 1
22	8308	Safety chain .....	2 2
23	9220	Outer shield .....	1 1
24	9221	Inner shield .....	1 1
25	9222	Complete shield .....	1 1

# GEAR BOX # 9714 (T301 inverted)

170-05311.tif

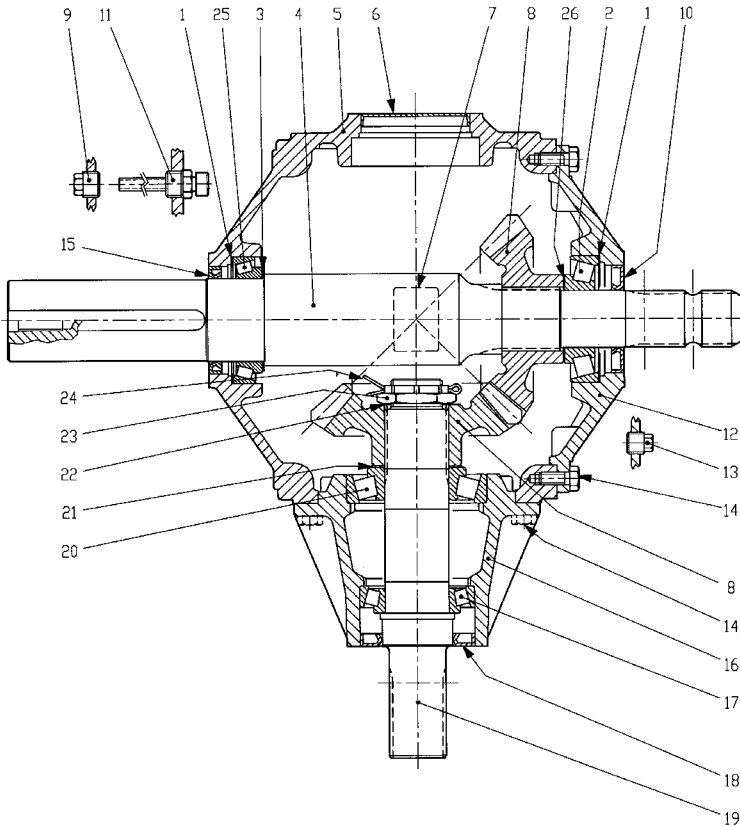

**Oil volume required: 2.5 liters**  
Use semi-synthetic **MOBIL SHC 320** or equivalent.

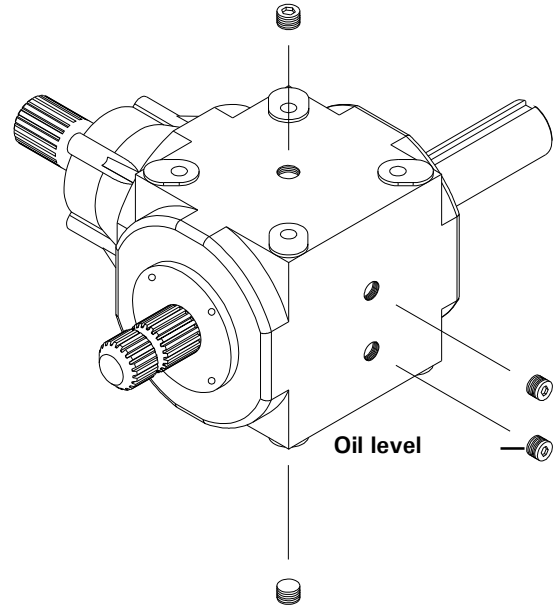

REF.	PART #	DESCRIPTION	QTY
1	9577	Shim .....	2
2	30309-A	Beraring 30309 .....	1
3	9578	Shim 79,7 .....	1
4	9729	Shaft .....	1
5	9579	Casing .....	1
6	9580	Cap .....	1
7	9730	Plate .....	1
8	9583	Gear Z20 M7.8 .....	2
9	9584	Plug 1/2" gas .....	1
10	9596	Oil seal 45 x 85 x 10 .....	1
11	9593	Plug 1/2G .....	1
12	9592	Cover .....	1
13	8064	Plug 3/8" gas .....	1
14	9576	Bolt M10x25 .....	18
15	9586	Oil seal 65 x 85 x 10 .....	1
16	9591	Extension .....	1
17	30210-A	Bearing 30210 .....	1
18	9590	Oil seal 55 x 90 x 10 .....	1
19	9589	Shaft Z20 1 3/4" .....	1
20	30310-A	Bearing 30310 .....	1
21	9588	Shim 70.3 .....	1
22	9587	Shim 40.3 x 1.0 .....	1
23	9581	Nut M40 x 1.5 .....	1
24	9582	Cotter pin B4 x 60 .....	1
25	32013X	Bearing 32013X .....	1
26	9578	Shim 45.3 x 65.3 .....	1



# CYLINDER 25TR08

15050

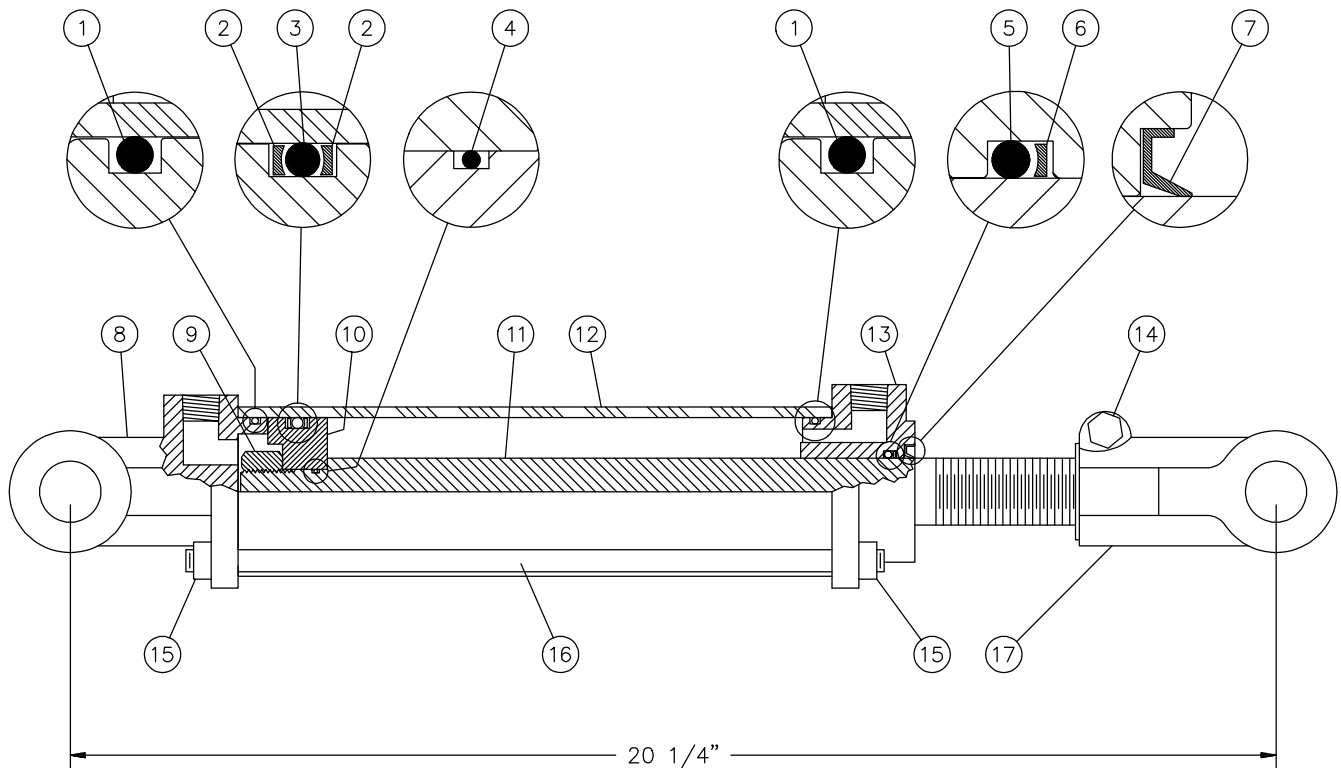

REF.	PART #	DESCRIPTION	QTY
1	See RK25TR	O-ring 1/8" x 2 1/4" x 2 1/2" .....	2
2	See RK25TR	Back-up 2 1/2" o.d. x 3/16 ø .....	2
3	See RK25TR	O-ring 3/16" x 2 1/8" x 2 1/2" .....	1
4	See RK25TR	O-ring 1/16" x 5/8" x 3/4" .....	1
5	See RK25TR	O-ring 1/8" x 1 1/8" x 1 3/8" .....	1
6	See RK25TR	Back-up 1 3/8" o.d. x 1/8" ø .....	1
7	See RK25TR	Wiper 1 1/8" i.d. x 1 5/8" o.d. ....	1
8	492401	Yoke (for tube 2 1/2") .....	1
9	Std.	Nut 3/4" NF .....	1
10	4924-31	Piston 2 1/2" ø .....	1
11	492028	Piston rod 1 1/8" .....	1
12	491668	Cylinder body 2 1/2" ø .....	1
13	492421	Head (for 2 1/2" tube) .....	1
14	Std.	Bolt 3/8" NC x 2 1/4" + nut .....	1
15	Std.	Nut 3/8" NC .....	8
16	Std.	Threaded rod 3/8" NC .....	4
17	458599	Yoke (for 1 1/8" rod) .....	1
NI*	8183	Pin 1" ø + cotter pin .....	2
NI*	RK25TR	Repair kit for cylinder 2 1/2" (includes # 1, 2, 3, 4, 5, 6, & 7) .....	1

\*NI = NOT ILLUSTRATED

# DEFLECTOR CYLINDER 15L12

170-05801

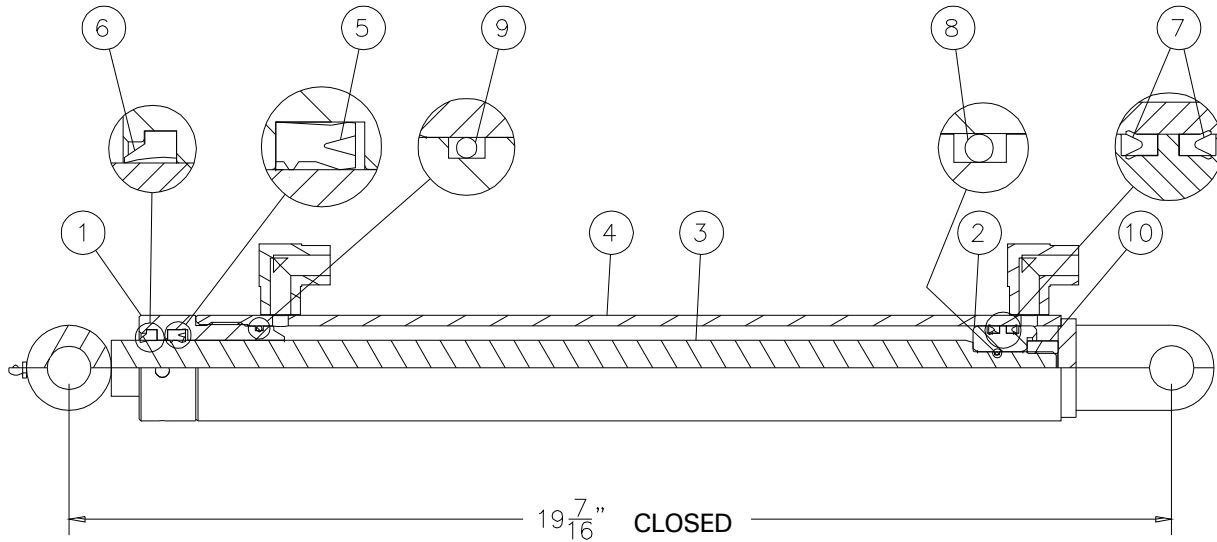

REF.	PART #	DESCRIPTION	QTY
1	150-06561	Head 1 1/2" dia. ....	1
2	150-06571	Piston 1 1/2" dia. ....	1
3	110-43122	Piston rod 1" dia. ....	1
4	110-43101	Cylinder body 1 1/2" dia. ....	1
5	DRTU-18-1.00-31	«U» seal 3/16" x 1" x 1 3/8" ....	1
6	ST-100	Wiper 3/16" x 1" x 1 3/8" ....	1
7	DSU12-1.25-18	«U» seal 3/16" x 1 1/4" x 1 1/2" ....	2
8	OR-014	O-ring 1/16" x 1/2" x 5/8" ....	1
9	OR-125	O-ring 3/32" x 1 5/16" x 1 1/2" ....	1
10	336-44000	Nut 5/8" NC ....	1
NI*	9689	Repair kit (includes # 5, 6, 7, 8 & 9) ....	1

\*NI = NOT ILLUSTRATED

# CYLINDER 15PC32

170-04361

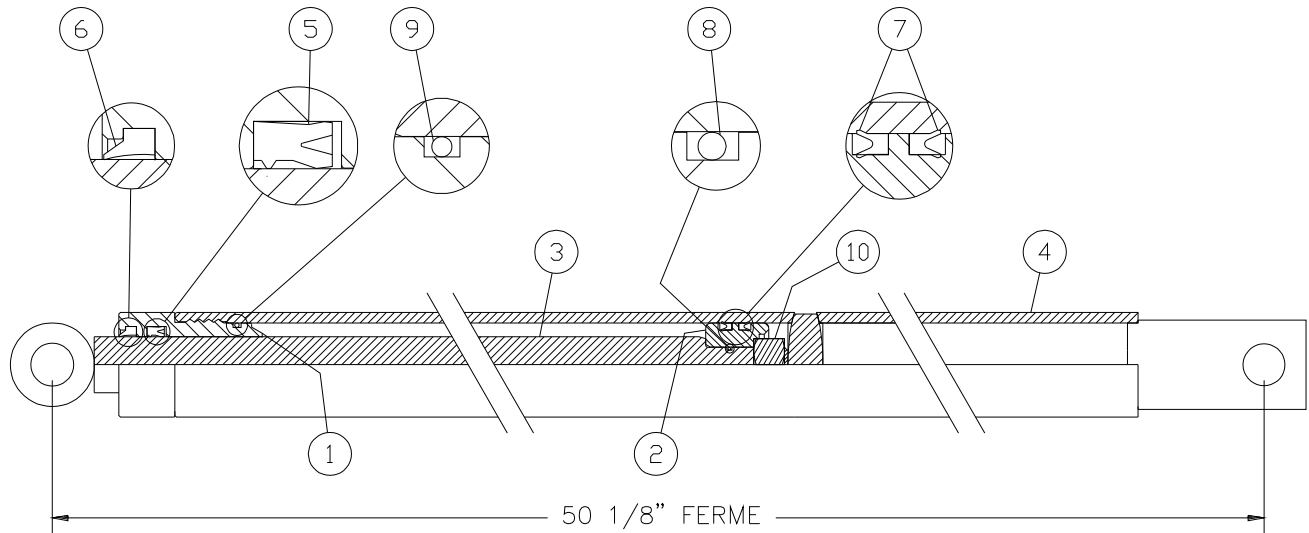

REF.	PART #	DESCRIPTION	QTY	
			15PC32D	15PC32G
1	150-06561	Head 1 1/2" dia. ....	1	1
2	150-06571	Piston 1 1/2" dia. ....	1	1
3	110-26561	Piston rod 1" dia. ....	1	1
4	110-29631	Cylinder body 1 1/2" dia. (15PC32D) ....	1	-
4	110-29632	Cylinder body 1 1/2" dia. (15PC32G) ....	-	1
5	DRTU-18-1.00-31	«U» seal 3/16" x 1" x 1 3/8" ....	1	1
6	ST-100	Wiper 3/16" x 1" x 1 1/8" ....	1	1
7	DSU12-1.25-18	«U» seal 3/16" x 1 1/4" x 1 1/2" ....	2	2
8	OR-014	O-ring 1/16" x 1/2" x 5/8" ....	1	1
9	OR-125	O-ring 3/32" x 1 5/16" x 1 1/2" ....	1	1
10	336-44000	Nut 5/8" NC ....	1	1
NI*	9689	Repair kit (includes # 5, 6, 7, 8 & 9) ....	1	1

\*NI = NOT ILLUSTRATED

# HYDRAULIC MOTOR # MLH315

## CUSHION VALVE H110

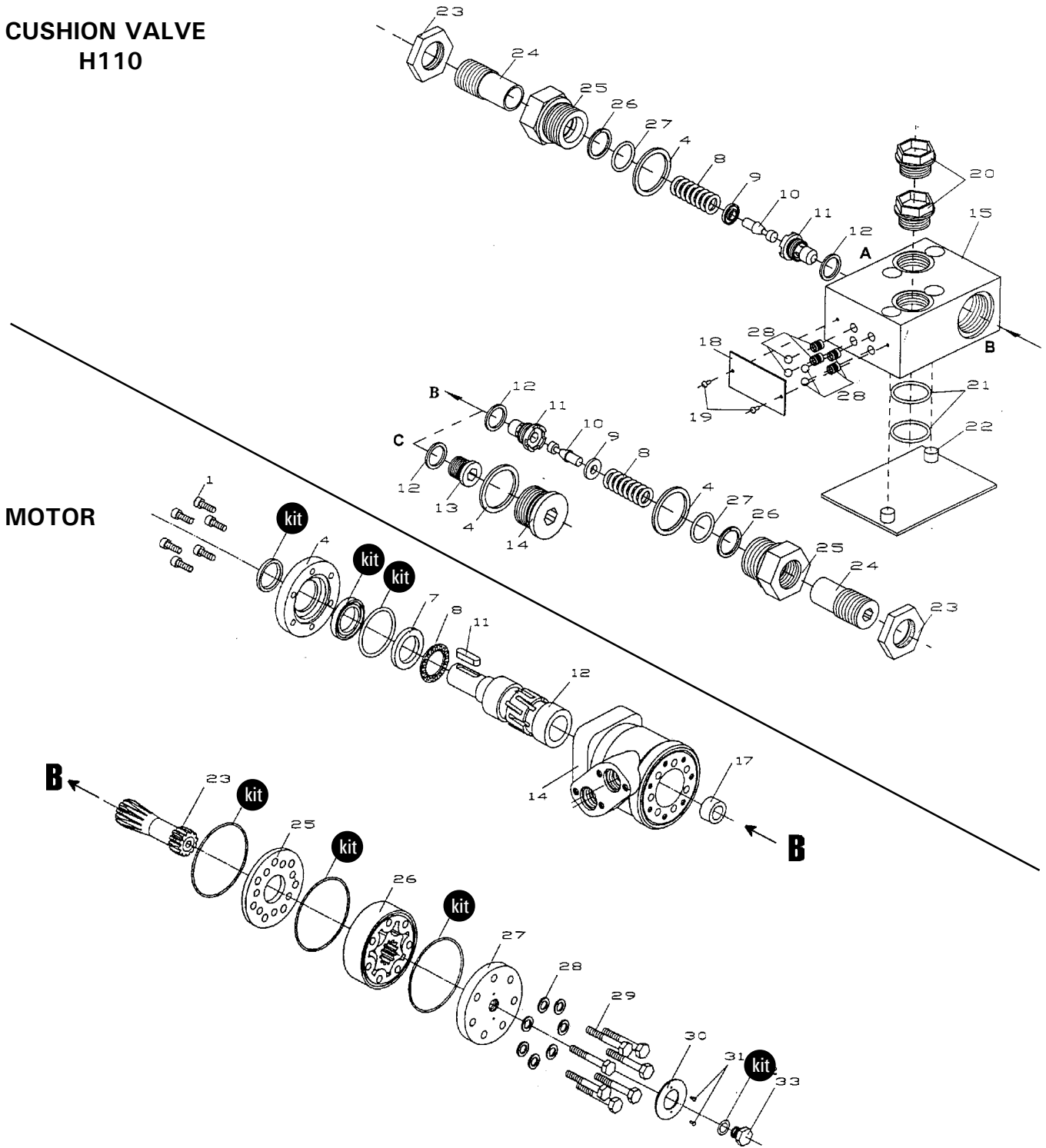







**10**





REF.	PART #	DESCRIPTION	QTY
kit	8368	Set of seals.....	1
11	8369	Key for "Orbit" motor.....	1

# TORQUE CHART

## TORQUE SPECIFICATION TABLE

Thread UNC and UNF		Grade 2 				Grade 5   				Grade 8*   			
Bolt size		Torque				Torque				Torque			
Inches	mm	Pound feet min.	max.	Newton meters min.	max.	Pound feet min.	max.	Newton meters min.	max.	Pound feet min.	max.	Newton meters min.	max.
1/4	6.35	5	6	6.8	8.13	9	11	12.2	14.9	12	15	16.3	30.3
5/16	7.94	10	12	13.6	16.3	17	20.5	23.1	27.8	24	29	32.5	39.3
3/8	9.53	20	23	27.1	31.2	35	42	47.5	57.0	45	54	61.0	73.2
7/16	11.11	30	35	40.7	47.4	54	64	73.2	86.8	70	84	94.9	113.9
1/2	12.70	45	52	61.0	70.5	80	96	108.5	130.2	110	132	149.2	179.0
9/16	14.29	65	75	88.1	101.6	110	132	149.2	179.0	160	192	217.0	260.4
5/8	15.88	95	105	128.7	142.3	150	180	203.4	244.1	220	264	298.3	358.0
3/4	19.05	150	185	203.3	250.7	270	324	366.1	439.3	380	456	515.3	618.3
7/8	22.23	160	200	216.8	271.0	400	480	542.4	650.9	600	720	813.6	976.3
1	25.40	250	300	338.8	406.5	580	696	786.5	943.8	900	1080	1220.4	1464.5
1 1/8	25.58	-	-	-	-	800	880	1084.8	1193.3	1280	1440	1735.7	1952.6
1 1/4	31.75	-	-	-	-	1120	1240	1518.7	1681.4	1820	2000	2467.9	2712.0
1 3/8	34.93	-	-	-	-	1460	1680	1979.8	2278.1	2380	2720	3227.3	3688.3
1 1/2	38.10	-	-	-	-	1940	2200	2630.6	2983.2	3160	3560	4285.0	4827.4

\* Thick nuts must be used with grade 8 bolts.

Size of screw	Thread	Pitch (mm)	Grade 4T  				Grade 7T 				Grade 8T  			
			Torque				Torque				Torque			
			Pound feet min.	max.	Newton meters min.	max.	Pound feet min.	max.	Newton meters min.	max.	Pound feet min.	max.	Newton meters min.	max.
M6	UNC	1.00	3.6	5.8	4.9	7.9	5.8	9.4	7.9	12.7	7.2	10	9.8	13.6
M8	UNC	1.25	7.2	14	9.8	19	17	22	23	29.8	20	26	27.1	35.2
M10	UNC	1.5	20	25	27.1	33.9	34	40	46.1	54.2	38	46	51.5	62.3
M12	UNC	1.75	28	34	37.9	46.1	51	59	69.1	79.9	57	66	77.2	89.4
M14	UNC	2.0	49	56	66.4	75.9	81	93	109.8	126	96	109	130.1	147.7
M16	UNC	2.0	67	77	90.8	104.3	116	130	157.2	176.2	129	145	174.8	196.5
M18	UNC	2.0	88	100	119.2	136	150	168	203.3	227.6	175	194	237.1	262.9
M20	UNC	2.5	108	130	146.3	176.2	186	205	252	277.8	213	249	288.6	337.4
M8	UNF	1.0	12	17	16.3	23	19	27	25.7	36.6	22	31	29.8	42
M10	UNF	1.25	20	29	27.1	39.3	35	47	47.4	63.7	40	52	54.2	70.5
M12	UNF	1.25	31	41	42	55.6	56	68	75.9	92.1	62	75	84	101.6
M14	UNF	1.5	52	64	70.5	86.7	90	106	122	143.6	107	124	145	168
M16	UNF	1.5	69	83	93.5	112.5	120	138	162.6	187	140	158	189.7	214.1
M18	UNF	1.5	100	117	136	158.5	177	199	239.8	269.6	202	231	273.7	313
M20	UNF	1.5	132	150	178.9	203.3	206	242	279.1	327.9	246	289	333.3	391.6

Use the above torques when special torque is not given.

NOTE: These values apply to fasteners as received from supplier, dry, or when lubricated with normal engine oil. They do not apply if extreme pressure lubricants are used.

---

---

## **WARRANTY**

---

**12**

PRONOVOST warrants this product to the initial purchaser for the period of one year from the date of purchase against defects in materials and workmanship.

We will replace or repair defective parts free of charge if they are returned to our plant in St-Tite, Quebec, Canada.

Transportation charges are the responsibility of the customer. This warranty is not transferable.

Hydraulic cylinders and motors are covered by the manufacturer of these items.

The PTO shafts are warranted by the manufacturer and cover **only** defects in material and workmanship, and is conditional to recommended use and installation only.

All PRONOVOST spare parts purchased are covered by a three (3) month warranty.

This warranty becomes void and nul if the equipment is modified, breaks down as the result of an accident, is not operated according to manufacturer's recommendations, damaged by negligence or if maintenance has not been carried out as specified.

Our obligation is limited to the replacement or repair of the defective part. PRONOVOST accepts no responsibility for direct or indirect consequential damages of any kind.



Ce manuel est aussi disponible en français.  
Veuillez téléphoner.



**LES MACHINERIES PRONOVOST INC.**  
260, Haut du Lac Sud (route 159),  
Saint-Tite, Quebec, Canada, G0X 3H0  
Tel.: (418) 365-7551, Fax: (418) 365-7954  
[www.pronovost.qc.ca](http://www.pronovost.qc.ca)