



**OPERATOR'S / PARTS
MANUAL**



Industrial snowblower
Model
P-982TRC-150



Copyright © Les Machineries Pronovost Inc., 2002

All rights reserved.
Printed in Canada.

TABLE OF CONTENTS

Section	Item	Page
1	Introduction	5
2	Safety	6
	General Safety	6
	Safety in operation	6
	Safety with maintenance	7
	Safety in transport	7
	Safety in storage	7
3	Decals	8
	Safety Decals	8
	Maintenance Decals	10
4	Assembly	11
	General assembly	11
5	Start-up	11
	Basic start-up Procedures	11
6	Maintenance	12
7	Storage	13
8	Trouble Shooting	14
9	Specifications	16
10	Parts List	17
	Snowblower P-982TRC-150	17
	Industrial Chute PC-IND	21
	Hydraulic Telescopic Chute PCTH-IND	23
	Semi-industrial Chute PSI-92104	25
	Industrial Chute PC-92104	27
	Hydraulic Telescopic chute PCTH-92104	29
	Hydraulic Lateral Blade	31
	Reduction gear box Options	32
	Reduction Gear Box # 9575	33
	Reduction Gear Box # 9606	34
	Reduction Gear Box # 9621	35
	P.T.O. # 9598, 9599, 9604	36
	Gear Box # 9307	37
	Cylinder 25TR08	38
	Cylinder # 190-03531	39
	Cylinder 20G28	40
	Hydraulic Motor MLH315	41
11	Torque chart	42
12	Warranty	43

INTRODUCTION

CONGRATULATIONS!

Thank you for choosing PRONOVOST. We are confident this equipment will meet your requirements in terms of quality, performance and reliability.

This manual was prepared to assist you in the safe operation of your new Snowblower. It contains important information which will help you achieve excellent returns with your Snowblower for years to come.

Please read this manual completely before operating your Snowblower and keep it for future reference.

Before starting the machine, you or any other person who will be operating the Snowblower must familiarize yourself with the safety recommendations and the operating instructions. Please read carefully and be sure to understand and follow all recommendations and procedures.

In this manual, the right and left sides are identified as shown on Figure 1.

If you require additional information on your Snowblower, please contact your PRONOVOST Dealer.

NOW take a moment to enter the model, serial number and the date of purchase of your Snowblower in the space provided.

When ordering parts from your Dealer, please refer to these numbers for a fast and efficient service. Use PRONOVOST parts for replacement.

The model and serial numbers are on the name plate shown on Fig. 1.

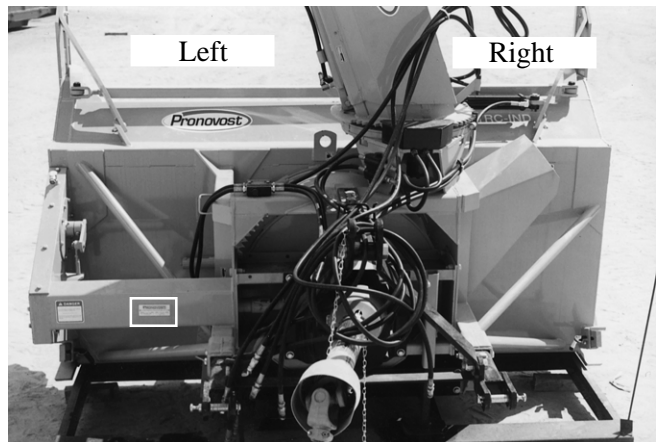

Figure 1

MODEL: _____ ✍

SERIAL NO: _____ ✍

DATE OF PURCHASE: _____ ✍

SAFETY

GENERAL SAFETY

2

WHEN YOU SEE THIS SYMBOL



ATTENTION!

**BE ALERT
YOUR SAFETY IS INVOLVED**

This symbol «SAFETY ALERT» is used in this manual and on the safety decals on the Snowblower. It warns you of the possibility of danger. Carefully read, understand and follow all safety recommendations before operating the Snowblower.

- 1) Careful operation is the best assurance against accidents. Carefully read this manual and follow all recommendations before operating your Snowblower. It is the owner's responsibility to make sure that anyone who will operate the Snowblower will read this manual before operating the equipment.
- 2) Familiarize yourself with all controls and always be ready to stop the Snowblower quickly in case of emergency.
- 3) Never let a child operate the Snowblower.
- 4) Do not modify the Snowblower. Any non authorized modification may affect the efficiency and/or safety of the equipment and will automatically void the warranty.
- 5) Never operate the Snowblower with defective parts or if damaged in any way. Have it repaired before operating.
- 6) Make sure all fasteners are in place and properly secured or tightened. Refer to torque chart on page 42.
- 7) Avoid wearing loose fitting clothing when working with the Snowblower. These could get entangled in moving parts of the equipment and cause accidents.
- 8) Prolonged exposure to noise may hamper hearing.

Protect yourself by wearing adequate protection devices.

- 9) Hydraulic fluids under pressure can damage your skin. Do not use your hands to locate a leak.
- 10) Before the beginning of the snow season, inspect all areas where the Snowblower will be used and remove any object which may cause an accident and/or damage the equipment.
- 11) Never operate your Snowblower in poor visibility or without proper lighting conditions.

SAFETY IN OPERATION

- 1) Be sure there are no obstructions around the equipment and that no one stands near the equipment when in operation.
- 2) Do not operate an engine in a confined or non ventilated area.
- 3) Do not perform any adjustments, cleaning, maintenance or repairs with the engine running. The engine must be stopped and the P.T.O. disengaged. Preferably remove the key from the ignition.
- 4) Wear adequate clothing when working in cold or windy conditions.
- 5) Adjust skid shoes for proper ground clearance of scraper blade, especially in rough terrain or soft ground conditions.
- 6) Before operating, make sure the P.T.O. is properly installed and secured.
- 7) Before starting-up the Snowblower, make sure the auger and drum areas are free of ice.
- 8) Put P.T.O. control in neutral position before starting engine.
- 9) Keep hands, feet and clothing away from moving parts of the Snowblower. Stay away from the discharge chute.

SAFETY (cont'd)

- 10) Before unplugging the chute, always disengage the P.T.O., stop the engine and relieve all hydraulic pressures.
- 11) Do not operate in excessive inclined conditions. Be careful when turning in slopes.
- 12) Never operate your Snowblower with missing guards or without protective devices in place.
- 13) Do not operate your Snowblower near buildings, windows or other vehicles without prior and proper adjustment of the chute deflector.
- 14) Never aim discharge chute towards people or animals. This may cause serious injuries.
- 15) Always reduce operating speed in slippery conditions.
- 16) Be careful when backing-up, make sure you have good visibility.
- 17) Always be on the lookout for objects which may enter the snowblower.
- 18) If undue vibrations are felt, disengage the P.T.O., stop the motor and look for the cause of the vibration. Vibration is usually the indication of a problem.
- 19) At the end of the operation, disengage the P.T.O., lower the Snowblower, put transmission in neutral, apply parking brake, stop engine and remove the key from the ignition.

SAFETY WITH MAINTENANCE

- 1) Perform the Snowblower maintenance according to recommendations contained in this manual.

- 2) Stop engine and relieve all hydraulic pressures before doing inspection, maintenance or repairs.
- 3) Never perform any work under the Snowblower while it is supported only by the tractor's hydraulic system. It must be completely supported by wooden blocks or other safe means.

SAFETY IN TRANSPORT

- 1) On public roads, use proper safety lights and check local regulations.
- 2) Be alert while driving on the road. Never carry passengers.
- 3) Always disengage P.T.O. while moving from one area of work to another.
- 4) It is recommended to use both brake pedals simultaneously for better control.
- 5) The recommended road speed should be such as to maintain full control over steering and braking.
- 6) Be careful while backing up, make sure you have good visibility.

SAFETY IN STORAGE

- 1) Provide adequate supports to prevent any accidental overturning of the Snowblower.
- 2) Do not let children play in the area where the Snowblower is stored.

2

DECALS

SAFETY DECALS

The safety decals are affixed wherever special safety precautions are indicated. Locate them on the machine and read them carefully. If a decal is damaged, lost or illegible, install a new one. The following photos indicate where each one must be installed.

3



Figure 3

⚠ ATTENTION

- 1- FOR SAFE OPERATION, FOLLOW OPERATING INSTRUCTIONS IN OPERATOR'S MANUAL.
- 2- KEEP HANDS, FEET AND CLOTHINGS AWAY FROM POWER DRIVEN PARTS.
- 3- STOP ENGINE BEFORE LEAVING THE EQUIPMENT.
- 4- MACHINE HAS TO BE COMPLETELY STOPPED BEFORE STARTING TO ADJUST OR LUBRICATE.
- 5- KEEP PEOPLE AND PETS AT SAFE DISTANCE FROM MACHINE.
- 6- KEEP ALL GUARDS AND SHIELDS IN PLACE.

- 1- POUR UN FONCTIONNEMENT SÉCURITAIRE SUIVRE LES INSTRUCTIONS DANS LE MANUEL D'OPÉRATION.
- 2- GARDER LES MAINS, PIEDS ET VÊTEMENTS ÉLOIGNÉS DES ÉLÉMENTS MOBILES OU ROTATIFS.
- 3- AVANT DE QUITTER LA MACHINE ARRÊTER LE MOTEUR.
- 4- ARRÊTER COMPLÈTEMENT LA MACHINE POUR EFFECTUER L'ENTRETIEN ET L'AJUSTEMENT.
- 5- GARDER LES GENS ET LES ANIMAUX À UNE DISTANCE SÉCURITAIRE.
- 6- GARDER TOUS LES ÉCRANS PROTECTEUR EN PLACE.

PA 93-01

Figure 2
Decal A

Part no.: A102

⚠ DANGER

TO AVOID SERIOUS INJURIES, KEEP CLEAR OF EQUIPMENT WHILE IN OPERATION.

POUR ÉVITER DES BLESSURES GRAVES SE TENIR LOIN DE CET ÉQUIPEMENT LORSQU'IL EST EN MARCHÉ.

PD 93-03

Figure 4
Decal B

Part no.: A101

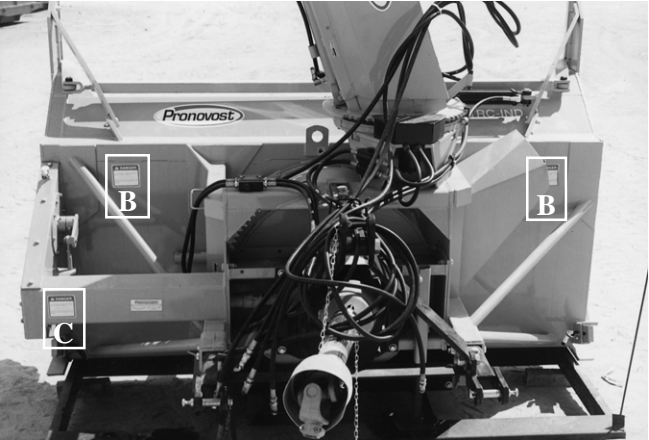

Figure 5

DECALS (cont'd)

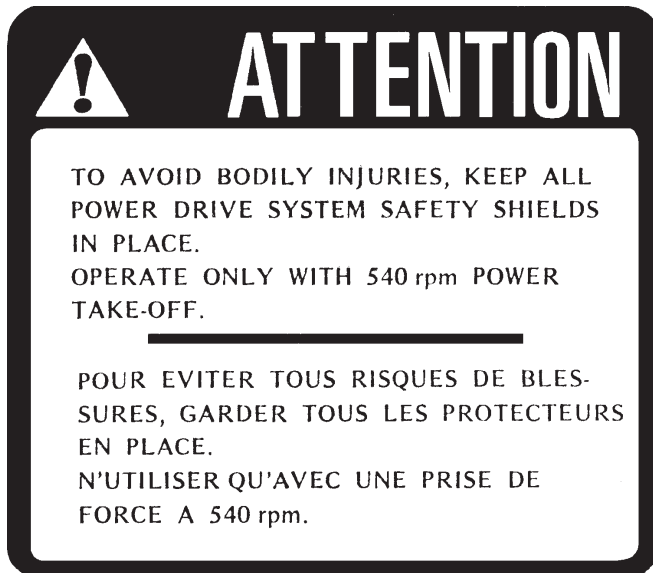

Figure 6
Decal C

Part no.: A112



Figure 7
Decal D

Part no.: A103

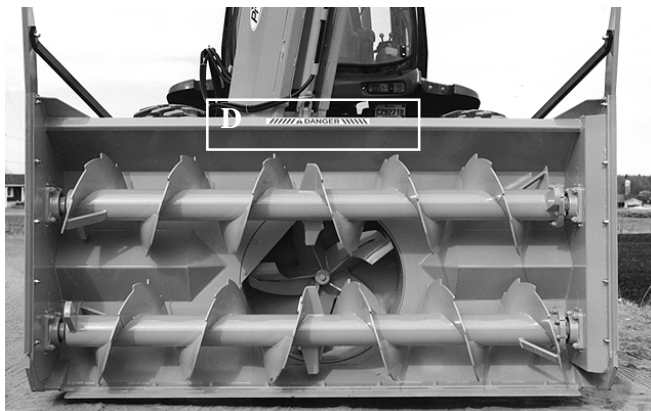

Figure 8

Decal E in Fig. 9 is located directly on the P.T.O. shaft. It is not visible when the safety shield is in place. It must never be visible when you operate the equipment.



Figure 9
Decal E

Part no.: A108

3

DECALS (cont'd)

3



Figure 10
Decal F

Part no.: A 109

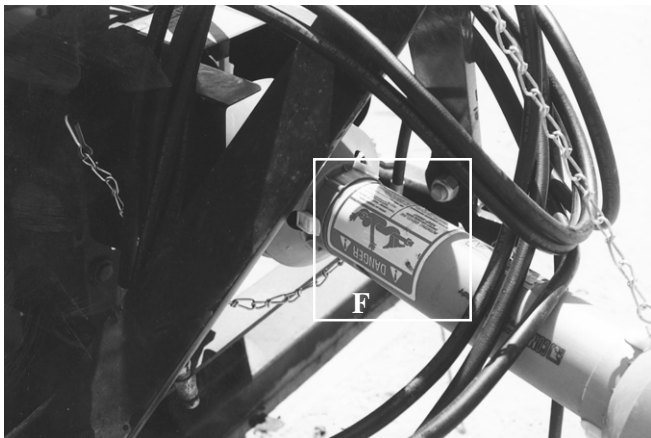
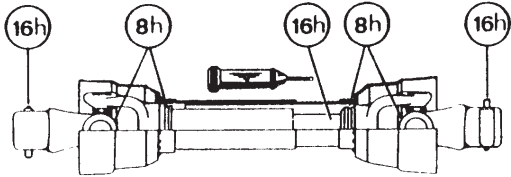

Figure 11

MAINTENANCE DECALS

The maintenance decals indicate the points requiring lubrication. Refer to maintenance section for more details.

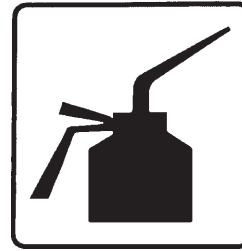

Figure 12

Part no.: A 105



Figure 13

Part no.: A 106



Figure 14
Decal G

Part no.: A104

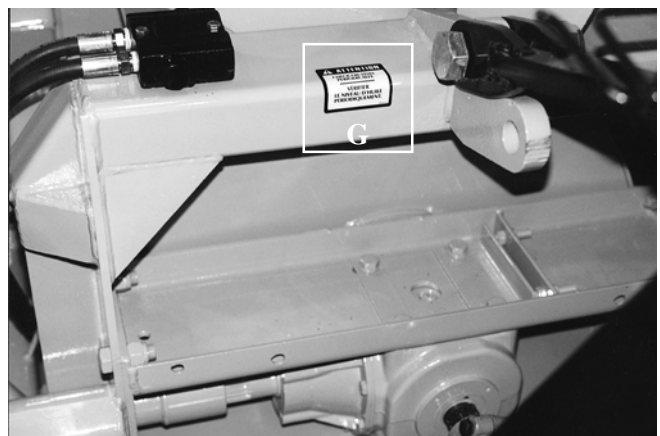

Figure 15

ASSEMBLY & STARTING-UP



Figure 16



Figure 17



Figure 18

ASSEMBLY

- 1) The Snowblower is shipped partly assembled.
- 2) Install P.T.O. shaft and place the shear pin end on the Snowblower side. Then attach safety shield support chain as shown (Fig. 16). **WARNING:** The telescoping tubes of the drive shaft must never be allowed to bottom out while maintaining a minimum overlap of 6 inches.

START-UP PROCEDURES

- 1) Check oil level in gearbox. Use S.A.E. W90 gear box oil.
- 2) Lubricate all points with a good quality multipurpose grease.
- 3) Check chain take-up adjustment. The spring maintaining the tension must be compressed to a length between 2 3/4" and 3 1/2".
- 4) Verify for adequate tightness of all fastening devices. Refer to torque chart on page 42.
- 5) Adjust skid shoes according to ground conditions (Fig. 17).
- 6) Use 540 RPM drive line or if your snowblower is equipped with a 1000 to 540 RPM speed reducer, use 1000 RPM drive line.
- 7) Check oil level in chain box (Fig. 18). Fill to level of plug. Use S.A.E. W90 gear oil.

4

5

MAINTENANCE

- 1) Wipe off all grease fittings with a clean cloth before adding grease in order to avoid injecting dirt and sand.
- 2) Repair or replace damaged grease fittings.
- 3) Lubricate all grease fittings every 10 hours of operation.
- 4) Oil drive chain every 8 hours of operation.
- 5) Lubricate P.T.O. shaft as indicated below:
- 6) Check oil level in gear box and chain case once a month. If necessary add oil.
- 7) Check tension of drive chain every 25 hours of operation and adjust if necessary.
- 8) Check for tightness of bearing collars every 50 hours of operation.
- 9) Change gearbox and chain case oil once a year. Use gear box oil S.A.E. W90 rated API, class GL-5.

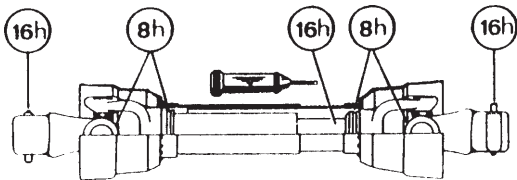

Pull out the P.T.O. And lubricate between the two tubes with low temperature grease.

- 10) Check all nuts and bolts once a year. If necessary use torque chart on page 42.
- 11) Always use suitable shear bolts.

STORAGE

- 1) Store the Snowblower in a cool, dry place.
- 2) Support the Snowblower with wooden blocks.
- 3) Keep all piston rods in the retracted position. This will assure better protection against the elements.
- 4) Clean your Snowblower.
- 5) Thoroughly inspect all parts of the Snowblower. Replace or repair worn or defective parts.
- 6) Touch-up or repaint if necessary.
- 7) Lubricate all points before storage.

TROUBLESHOOTING

P.T.O. SHAFT

PROBLEM	POSSIBLE CAUSE	CORRECTION
<ul style="list-style-type: none"> - Premature wear of U-joints and/ or bluish color of cross journals. 	<ul style="list-style-type: none"> - Insufficient lubrication. - Excessive working angle. - Poor quality lubricant. 	<ul style="list-style-type: none"> - Follow lubrication recommendations. - Replace defective U-joints. - Make sure the Snowblower inlet face is perpendicular to the ground and if possible readjust 3-point hitch in order to position the Snowblower further away from tractor. - Use high quality lubricant.
<ul style="list-style-type: none"> - Gripping or premature wear of telescoping members. 	<ul style="list-style-type: none"> - Too much sliding under load. - Tube overlap too-short: minimum recommended is 6". - Insufficient lubrication. - Contaminants (sand, etc.). 	<ul style="list-style-type: none"> - Avoid raising Snowblower while in operation. - Readjust 3-point hitch in order to position the Snowblower closer to the tractor. - Follow lubrication recommendations. - Replace defective telescopic members.
<ul style="list-style-type: none"> - Damaged or jammed locking pin or bolt. 	<ul style="list-style-type: none"> - Pin or orifice contaminated by sand, ice, etc. - Telescoping members too long, exerting pressure on locking device. 	<ul style="list-style-type: none"> - Clean and grease. - Readjust 3-point hitch in order to position the Snowblower further away from tractor or shorten tubes.
<ul style="list-style-type: none"> - Premature wear of guard tube bearing ring. 	<ul style="list-style-type: none"> - Lack of lubrication. - Wrong installation of guard chain. - Part of the guard in contact with the equipment. 	<ul style="list-style-type: none"> - Follow lubrication instructions. - Adjust chain to prevent interference between guard & equipment. - Replace worn or damaged bearing rings.
<ul style="list-style-type: none"> - Cut or deformed safety guard tubes. 	<ul style="list-style-type: none"> - Tubes in contact with the equipment. 	<ul style="list-style-type: none"> - Eliminate any interference between tubes and equipment or tractor. - Replace damaged tubes.

8

TROUBLESHOOTING (cont'd)

SNOWBLOWER

PROBLEM	POSSIBLE CAUSE	CORRECTION
- The snow is not being thrown as far as usual.	- Tractor RPM too low. - Gap too wide between impeller blade tip and drum outlet wall. - Insufficient tractor HP.	- Raise P.T.O. speed to a minimum of 540 RPM. - Adjust impeller blades closer to drum outlet (1/8" to 3/16"). - Reduce travel speed.
- Frequent plugging of discharge chute.	- Tractor RPM too low. - Tractor RPM reduced too early with snow still in the Snowblower. - Slippage of PTO clutch mechanism. - Wet snow condition.	- Raise P.T.O. speed to a minimum of 540 RPM. - Make sure the Snowblower is completely empty before reducing RPM, especially on tractors with foot controlled RPM. - Repare clutch. - Reduce travel speed.
- The impeller will not turn.	- Shear bolt broken on drive shaft.	- Replace shear bolt.
- The auger will not turn.	- Shear bolt broken on drive shaft. - Shear bolt broken on auger drive shaft. - Broken drive chain.	- Replace shear bolt. - Replace shear bolt. - Fix or replace chain.
- The rotating drum will not turn.	- Ice accumulation. - Wrong hydraulic connections.	- Remove ice. - Check hydraulic connections.
- Rotating drum will not hold it's position when blowing via the spout.	- Cushion valve setting too low. - Tension of the spring in the drum locking mechanism insufficient.	- Reset cushion valve up to 1800 psi (max.) - Increase tension of spring by adding shim(s).
- The chute will not turn.	- Ice accumulation. - Wrong hydraulic connections.	- Remove ice. - Check hydraulic connections.

SPECIFICATIONS

Model	P-982TRC-200	
Horse power required	100 to 150 HP	
Approximative performance	800 tons imp. / hour with 125 HP tractor	
Height including telescopic chute	149" extended / 123" retracted	
Frame height	48"	
Lateral blades height	65"	
Working width	98"	
Impeller diameter	30"	
Depth of drum	15"	
Impeller blades	6 replaceable 3/8" carbon steel blades	
Shear bolt	1 for the impeller + 1 for the auger drive	
Size of impeller shaft	2"	
P.T.O. speed required	540 RPM without reducer 1000 RPM with reducer	
Reducer	Optional (150 HP at 1000 RPM) 1000/540 RPM (1.86 to 1 ratio)	
Impeller speed	540 RPM	
Number of augers	2 x 18" full flight spiked augers Optional: full flight spiked augers with welded carbon steel teeth	
Auger ball bearing	2" (with ductile flange)	
Drive chain	No. 100HD in oil bath	
Replaceable scraper blade	6" x 1/2" carbon steel sharpened	
Adjustable skid shoes	Carbon steel	
Drum rotation	Hydraulic motor and cushion valve included	
Chute rotation	Hydraulic motor and cushion valve included	
P.T.O. shaft	No. 9 (V90) Yoke 1 3/8"-6 splines for tractor output 540 RPM Yoke 1 3/8"-21 splines for tractor output 1000 RPM Yoke 1 3/4"-20 splines for tractor output 1000 RPM	
3-point hitch	Category 2	
Frame	Sides	5/16"
	Back	9 gages
	Drum	Carbon steel 1/4"
Weight	3700 lbs (with telescopic chute)	

9

Design and specifications subject to change without notice.

INDUSTRIAL SNOWBLOWER P-982TRC-150

170-02645

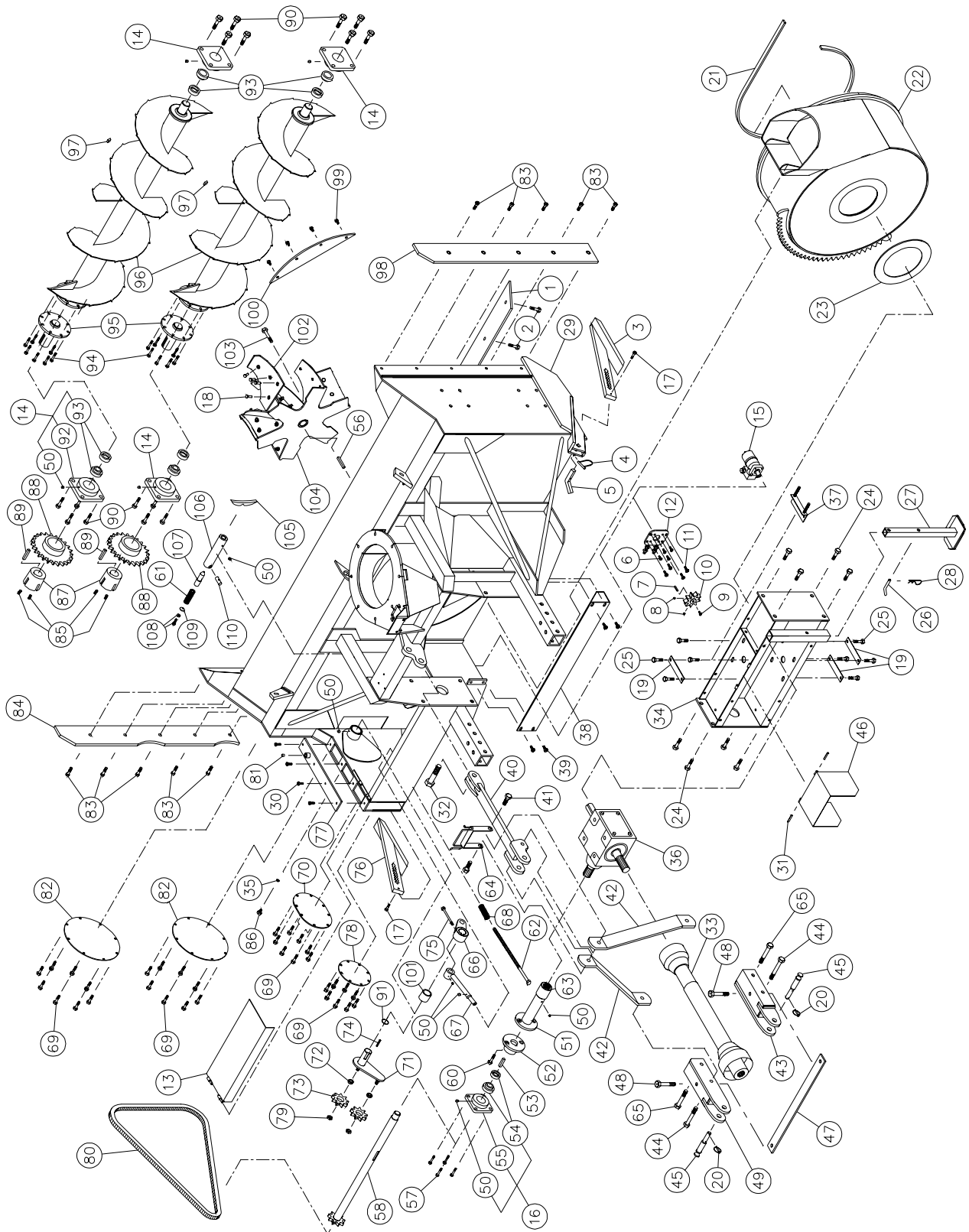

INDUSTRIAL SNOWBLOWER P-982TRC-150 (cont'd)

REF.	PART #	DESCRIPTION	QTY
1	140-10512	Scraper blade, carbon steel, not reversible, sharpened 1/2"x6"x90 7/8" lg	1
2	319-40340	Plow bolt 1/2" NC x 2" lg + nut & lock washer	9
3	110-05511	Skid shoe (right side)	1
4	8112	Lock pin 1/4"	2
5	140-03361	Skid shoes lock	2
6	300-36250	Bolt 3/8" NC x 1" lg + nylon locknut	4
7	8369	Key for hydraulic motor	1
8	323-36160	Hexagonal socket set screw 3/8"-16 x 3/8" lg.	2
9	300-32220	Bolt 1/4" NC x 3/4" lg + lock washer	1
10	110-04721	Sprocket 9 teeth	1
11	300-38310	Bolt 7/16" NC x 1 1/2" lg + nylon locknut + flat washer	4
12	110-18441	Orbit motor support + 4 nut 7/16" NC	1
13	110-21381	Drive shaft guard	1
14	HCFS211-32	Bearing 2" + flange + 1 grease fitting	4
15	MLH315	Hydraulic motor with cushion valve	1
16	HCFS209-28	Bearing 1 3/4" + flange + 1 grease fitting	1
17	300-32310	Bolt 1/4" NC x 1 1/2" lg + nylon locknut	2
18	319-40325	Plow bolt 1/2" NC x 1 3/4" lg + nut & lock washer	24
19	140-10761	Back plate	3
20	Std.	Lynch pin 1/4" x 1 3/4"	2
21	190-03741	U-shaped UHMW 3/8" x 7/8" x 97 3/16" lg	1
22	110-14781	Rotary drum 30" dia.	1
23	9432	UHMW flat washer 3/16" x 8 7/8" i.d. x 12" o.d.	1
24	300-46340	Bolt 3/4" NC x 2" lg + nylon locknut	8
25	300-44280	Bolt 5/8" NC x 1 1/4" lg + lock washer	8
26	8220	Storage support pin	1
27	9462	Storage support	1
28	Std.	Hitch pin clip 5/32"	1
29	120-03652	Frame P-982TRC-150	1
30	300-38250	Bolt 7/16" NC x 1" lg + lock washer	4
31	Std.	Roll pin 5/16" x 2" lg	2
32	300-54490	Bolt 1 1/4" NC x 4 1/2" lg+ nylon locknut	1
33	9599	P.T.O. shaft V90 1 3/8"-21 splines	as required
33	9598	P.T.O. shaft V90 1 3/8"-6 splines	as required
33	9604	P.T.O. shaft V90 1 3/4"-20 splines	as required
34	110-01682	Gear box support	1
35	190-03551	Copper washer 7/16" i.d. x 5/8" o.d. (oil level plug)	1
36	9307	Gear box T-279	1
37	110-05281	Adjustment plate for gear box + 4 nuts 1/2" NC	1
38	130-26941	Guard for ring gear segment	1
39	300-40280	Bolt 1/2" NC x 1 1/4" lg + nylon locknut + flat washer	4
40	110-15311	Upper hitch	1
41	300-46400	Bolt 3/4" NC x 3" lg + nylon locknut + flat washer 1 1/2" o.d.	2
42	140-05472	3-point side bar	2
43	110-15214	Right lower hitch	1
44	302-46610	Bolt 3/4" NF x 6 1/2" lg + nylon locknut	2
45	9269	Pin category 2	2
46	110-12541	Hinged P.T.O. shroud	1
47	140-03441	3-point hitch reinforcement	1
48	302-46550	Bolt 3/4" NF x 5 1/2" lg + nylon locknut	2
49	110-15213	Left lower hitch	1

INDUSTRIAL SNOWBLOWER P-982TRC-150

REF.	PART #	DESCRIPTION	QTY
50	Std.	Grease fitting 1/4-28 straight	10
51	110-11371	Side shaft & shearplate (long side) + splined adaptor (20 splines)	1
52	110-11361	Side shaft & shearplate (short side)	1
53	140-08541	Key for auger drive shaft & shearplate (short side)	1
54	HC209-28	Bearing 1 3/4" with eccentric collar	1
55	FS209	Flange 4 holes	1
56	9285	Key for impeller	1
57	300-44340	Bolt 5/8" NC x 2" lg + nylon locknut	4
58	110-14631	Auger drive shaft 35-9/16" lg	1
60	300-38355	Bolt 7/16" NC x 2 1/4" lg + nylon locknut	1
61	9473	Compression spring	1
62	110-17751	Threaded rod for idler adjustment	1
63	110-13441	Splined adaptor 1 3/4" - 20 (welded) with bronze bushing	1
64	110-15201	Hoses support	1
65	302-46580	Bolt 3/4" NF x 6" lg + nylon locknut	2
66	110-17731	Idler (outside part)	1
67	110-17761	Threaded tube for idler adjustment	1
68	9605	Compression spring	1
69	300-38220	Bolt 7/16" NC x 3/4" lg + lock washer	32
70	130-12402	Idler cover	1
71	110-17771	Idler (inside part)	1
72	160-02171	Spacer	2
73	9470	Idler sprocket no 100A9 H3/4	2
74	140-12161	Idler key	1
75	300-40460	Bolt 1/2" NC x 4" lg GR 12 + nylon locknut	1
76	110-04811	Skid shoe (left side)	1
77	110-13862	Upper chain guard cover	1
78	130-12391	Chain guard cover (left side)	1
79	346-47000	Nylon locknut 3/4" NC thin	2
80	190-03452	Chain #100 HD x 115" (92 links)	1
80	59-100 HD	Offset link #100 HD	1
80	26A100 HD	Connecting link #100 HD	1
81	9619	Vent plug 1/2" NPT	1
82	130-12381	Chain guard cover	2
83	319-40325	Plow bolt 1/2" NC x 1 3/4" lg + nut & lock washer	10
84	130-19591	Left lateral blade	1
85	323-44280	Hexagonal socket set screw 5/8"-11 x 1-1/4 lg	4
86	300-38280	Bolt 7/16" NC x 1 1/4" lg	1
87	9620	Male adaptor "taper-lock"	2
88	110-13321	Sprocket for auger 100A24 x 1T 5.125 + female adaptor "taper-lock"	2
89	140-09411	Key (sprocket for auger)	2
90	300-44340	Bolt 5/8" NC x 2" lg + nylon locknut	16
91	OR-224	Seal 1/8" x 1 3/4" i.d. x 2" o.d.	1
92	FS211	Flange 4 holes	4
93	HC211-32	Bearing 2" with eccentric collar	4
94	300-40325	Bolt 1/2" NC x 1 3/4" lg + nut & lock washer	16
95	110-12591	Auger hub	2
96	110-14711	Full flight spiked auger	2
96	110-16461	Full flight spiked auger with welded carbon steel teeth	opt.
97	130-13861	Carbon steel tooth on the auger (104)	opt.
98	130-19581	Right lateral blade	1

INDUSTRIAL SNOWBLOWER P-982TRC-150

REF.	PART #	DESCRIPTION	QTY
99	300-38280	Bolt 7/16" NC x 1 1/4" lg + nylon locknut	4
100	130-02111	Deflector	1
101	160-08421	Aluminium bronze bushing 1 3/4" i.d. x 2" lg	1
102	130-25321	Impeller blade	6
103	300-44310	Bolt 5/8" NC x 1 1/2" lg +lock washer	1
104	110-16392	Impeller with bolted blades	1
105	130-08441	Stop block for drum lock (welded on drum)	1
106	160-03952	Body - drum lock (welded on frame)	1
107	150-01542	Latch pin - drum lock	1
108	300-38325	Bolt 7/16" NC x 1 3/4" lg (full length thread) + lock nut	1
109	130-08471	Washer	1
110	150-02561	Pin	1

INDUSTRIAL CHUTE PC-IND

HEAVY DUTY MODEL

170-02405

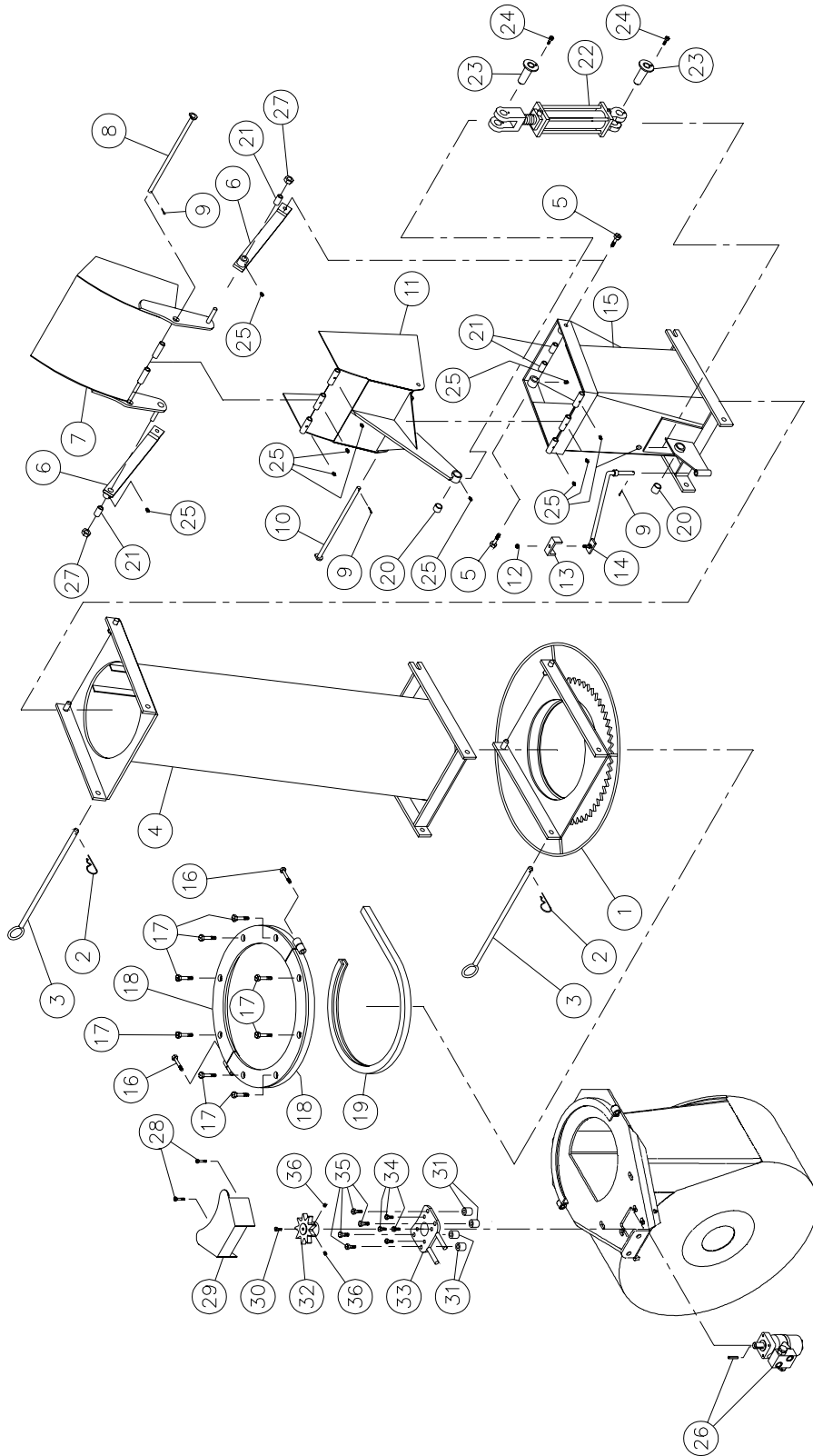

INDUSTRIAL CHUTE PC-IND

REF.	PART #	DESCRIPTION	QTY
1	110-00681	Chute adaptor with quick attach	1
2	Std.	Hitch pin clip 5/32"	2
3	9414	Pin for quick attach (adaptor & extension)	2
4	PR-IND	Extension 48"	opt.
5	300-40310	Bolt 1/2" NC x 1 1/2" lg + nylon locknut	2
6	110-19181	Connecting rod	2
7	110-13502	Upper deflector	1
8	110-13381	Upper deflector pin	1
9	Std.	Cotter pin 1/8" x 1" lg	3
10	110-13371	Lower deflector pin	1
11	110-13511	Lower deflector	1
12	346-34000	Nylon locknut 5/16" NC	1
13	140-00881	Hoses support plate	1
14	110-01111	Hoses support rod	1
15	110-14631	Chute base	1
16	300-38400	Bolt 7/16" NC x 3" lg + nylon locknut	2
17	300-40400	Bolt 1/2" NC x 3"lg + nylon locknut & 2 flat washer	8
18	110-12351	Retaining bracket	2
19	190-03381	U-shaped UHMW +/- 16" i.d.	1
20	160-06221	Brass tube 1 1/2" o.d. x 1" i.d. x 1" lg	2
21	160-06391	Tube 3/4" o.d. x 1/2" i.d. x 1 5/16" lg	4
22	190-03531	Cylinder 25TR08	1
23	110-12401	Cylinder pin (25TR08)	2
24	300-32220	Bolt 1/4" NC x 3/4" lg + lock washer	2
25	Std.	Grease fitting 1/4"-28 straight	12
26	MLH315	Orbit hydraulic motor with cushion valve	opt.
27	346-40000	Nylon locknut 1/2"	2
28	300-34280	Bolt 5/16" NC x 1 1/4" lg + nylon locknut	2
29	130-14281	Guard	1
30	300-32310	Bolt 1/4" NC x 1 1/2" lg + lockwasher	1
31	160-01331	Spacer 1/2" i.d. x 1" o.d. x 59/64" lg	4
32	110-04721	Sprocket (9 teeth)	1
33	130-08152	Orbit motor support	1
34	300-36250	Bolt 3/8" NC x 1" lg + lock washer	4
35	300-38370	Bolt 7/16" NC x 2 1/2" lg + nylon locknut & flat washer	4
36	323-36160	Hexagonal socket set screw 3/8" NC x 3/8" lg	2

HYDRAULIC TELESCOPIC CHUTE PCTH-IND

HEAVY DUTY MODEL

170-02395

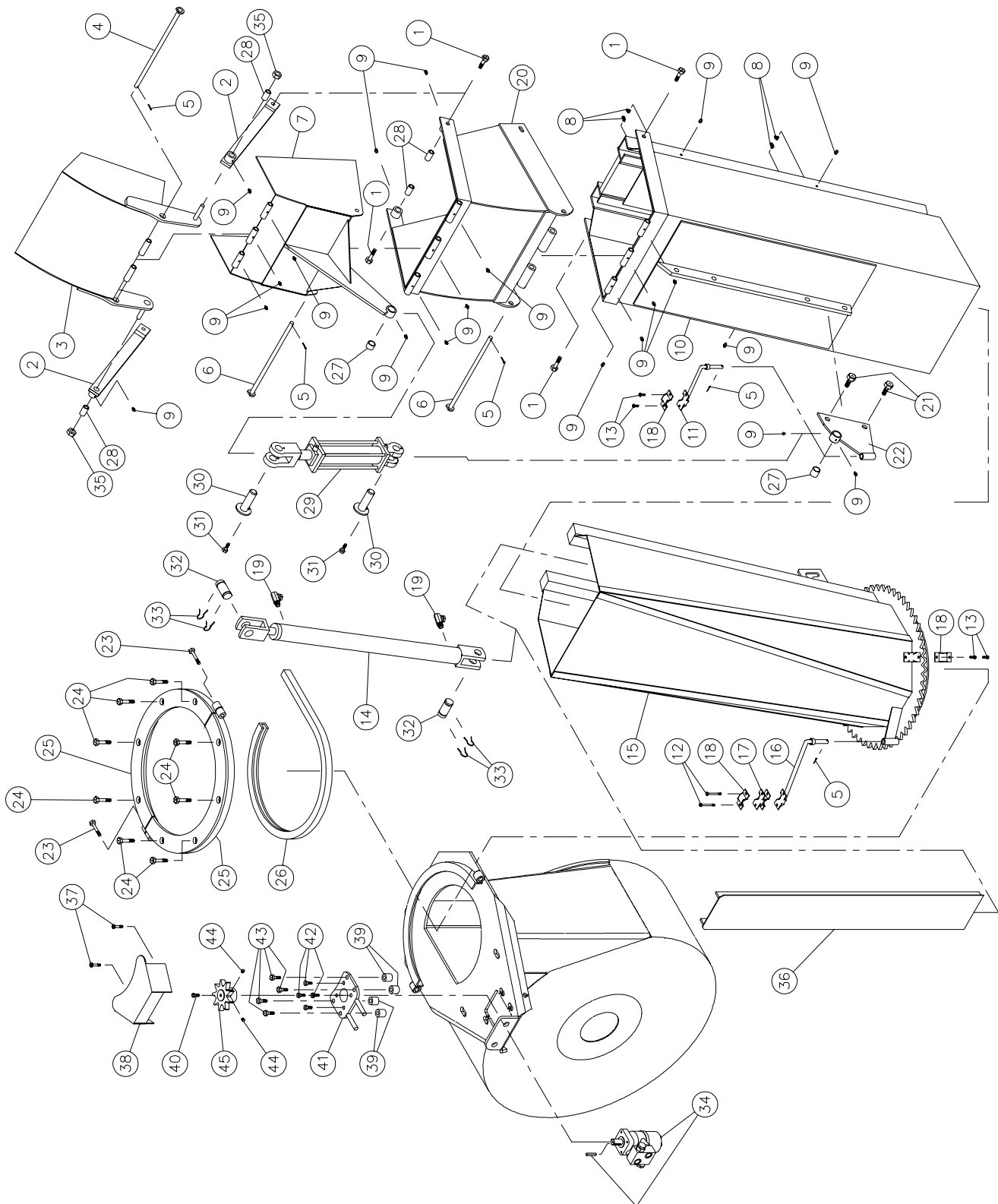

HYDRAULIC TELESCOPIC CHUTE PCTH-IND

HEAVY DUTY MODEL

REF.	PART #	DESCRIPTION	QTY
1	300-40370	Bolt ½" NC x 2½ lg + nylon locknut	4
2	110-19161	Connecting rod	2
3	110-13462	Upper chute deflector	1
4	110-12801	Upper chute deflector pin	1
5	Std.	Cotter pin 1/8" x 1" lg	5
6	110-12761	Lower chute deflector pin	2
7	110-13491	Lower chute deflector	1
8	Std.	Grease fitting 1/4" - 28 90°	4
9	Std.	Grease fitting 1/4" - 28 straight	19
10	110-13721	Rallonge supérieure	1
11	110-01122	Tige de support des boyaux de la rallonge supérieure	1
12	140-00881	Plaque de fixation des boyaux	1
13	346-34000	Écrou à blocage de nylon 5/16" NC	2
14	20G28	Cylindre 2" x 28" de course	1
15	110-13731	Rallonge inférieure	1
16	110-04981	Tige de support des boyaux de la rallonge inférieure	1
17	110-20611	Hoses mounting plate	1
18	140-13071	Hoses mounting plate	1
19	9405-6-6	Fitting 3/8" NPT swivel 90 deg.	2
20	110-13521	Extension 16"	1
21	300-44340	Bolt 5/8" NC x 2" lg + nylon locknut	2
22	110-12381	Ajustable stanchion for deflector cylinder	1
23	300-38400	Bolt 7/16" NC x 3" lg + nylon locknut	2
24	300-40400	Bolt 1/2" NC x 3" lg + nylon locknut & 2 flat washer	8
25	110-12351	Retaining bracket	2
26	190-03381	U-shaod UHMW +/- 16" i.d.	1
27	160-06221	Aluminium - bronze bushing 1 1/2" d.e. x 1" d.i. x 1" lg	2
28	160-06391	Tube 3/4" o.d. x 1/2" i.d. x 1 5/16" lg	4
29	190-03531	Cylinder 25TR08 modified	1
30	110-12401	Pin for cylinder 25TR08	2
31	300-32220	Bolt 1/4" NC x 3/4" lg + lock washer	2
32	D6005-1	Pin for cylinder 1" x 3 1/8" lg	2
33	Std.	Hair pin 7/8"	4
34	MLH315	Orbit hydraulic motor with cushion valve	opt.
35	346-40000	Nylon locknut 1/2"	2
36	110-18301	Door for chute	1
37	300-34280	Bolt 5/16" NC x 1 1/4" lg + nylon locknut	2
38	130-14281	Guard	1
39	160-01331	Spacer 1/2" i.d. x 1" o.d. x 59/64" lg	4
40	300-32310	Bolt 1/4" NC x 1 1/2" lg + lock washer	1
41	130-08152	Orbit motor mounting plate	1
42	300-36250	Bolt 3/8 NC x 1" lg + lock washer	4
43	300-38370	Bolt 7/16" NC x 2 1/2" lg + nylon locknut & flat washer	4
44	323-36160	Hexagonal socket head set screw 3/8" NC x 3/8" lg	2
45	110-04721	Sprocker (9 teeth)	1

SEMI-INDUSTRIAL CHUTE PSI-92104 (for industrial snowblower)

170-02675

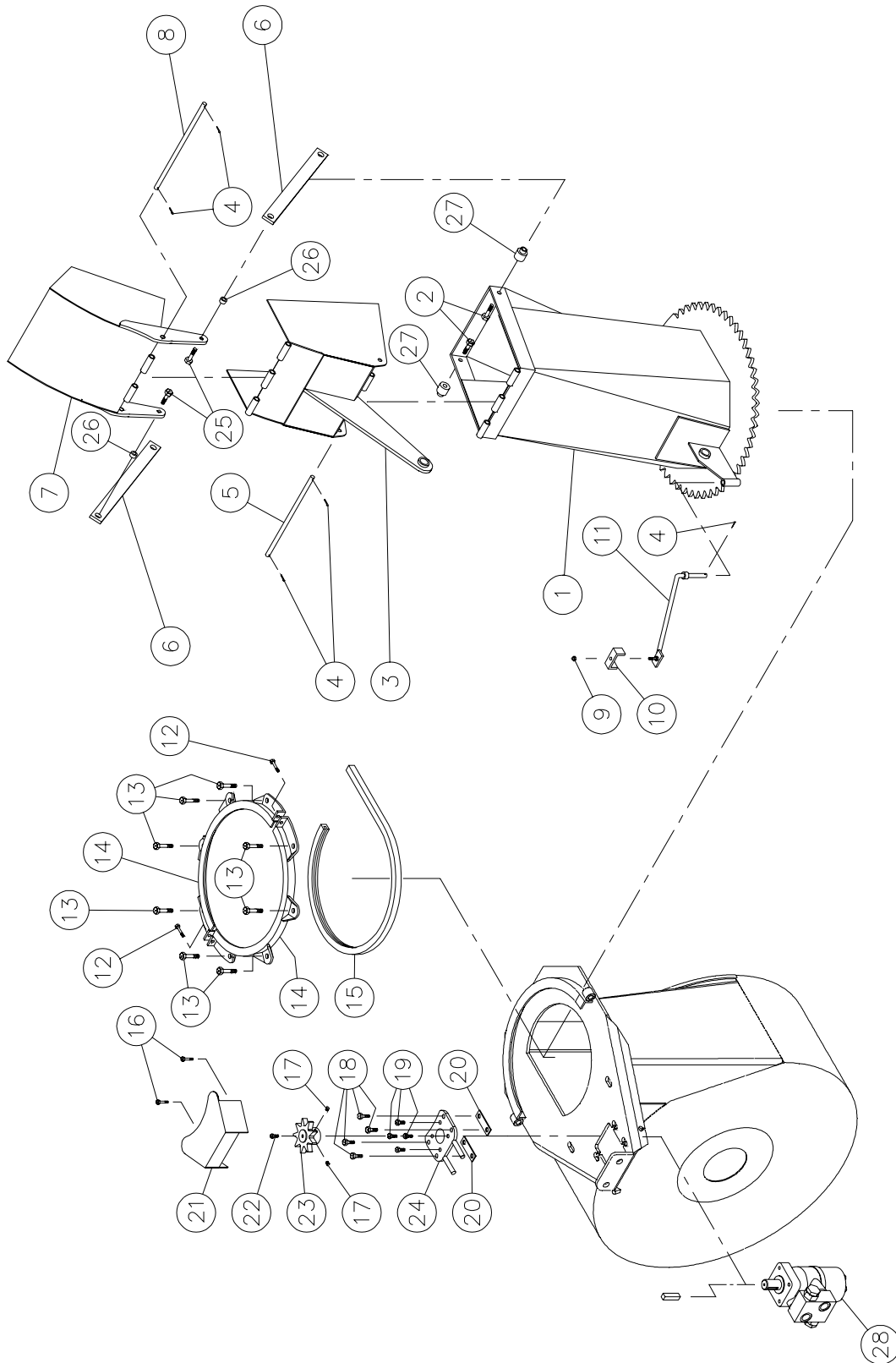

SEMI-INDUSTRIAL CHUTE PSI-92104 (for industrial snowblower)

REF.	PART #	DESCRIPTION	QTY
1	110-01581	Chute base	1
2	300-40370	Bolt ½" NC x 3" lg + flat washer & nylon lock nut	4
3	110-18291	Lower chute deflector	1
4	Std.	Cotter pin 1/8" x 1" lg	5
5	9418	Lower chute deflector pin	1
6	140-11721	Connecting rod	2
7	110-18141	Upper chute deflector	1
8	9417	Upper chute deflector pin	1
9	346-34000	Nylon locknut 5/16" NC	1
10	140-00881	Hoses support plate	1
11	110-01111	Hoses support rod	1
12	300-34340	Bolt 5/16" NC x 2" lg + nylon locknut	2
13	300-40310	Bolt 1/2" NC x 1 1/2" lg + nylon locknut & flat washer	8
14	110-00832	Retaining bracket	2
15	9359	U-shaped UHMW +/- 16 1/2" d.i.	1
16	300-34280	Bolt 5/16" NC x 1 1/4" lg + nylon locknut	2
17	323-36160	Hexagonal socket set screw 3/8" NC x 3/8" lg	2
18	300-38310	Bolt 7/16" NC x 1 1/2 lg + nylon locknut & flat washer	4
19	300-36250	Bolt 3/8" NC x 1" lg + lock washer	4
20	140-09571	Spacer 1/8" x 1" x 3 1/4" lg	2
21	130-14281	Guard	1
22	300-32220	Bolt 1/4" NC x 3/4" lg + lock washer	1
23	110-04721	Sprocket (9 teeth)	1
24	130-08151	Orbit motor support	1
25	319-38280	Plow bolt 7/16" NC x 1 1/4" lg + nylon locknut & flat washer	2
26	150-03831	Spacer for connecting rod (top)	2
27	150-03871	Spacer for connecting rod (bottom)	2
28	MLH315	Orbit hydraulic motor with cushion valve	opt.

INDUSTRIAL CHUTE PC-92104 (for industrial snowblower)

170-02665

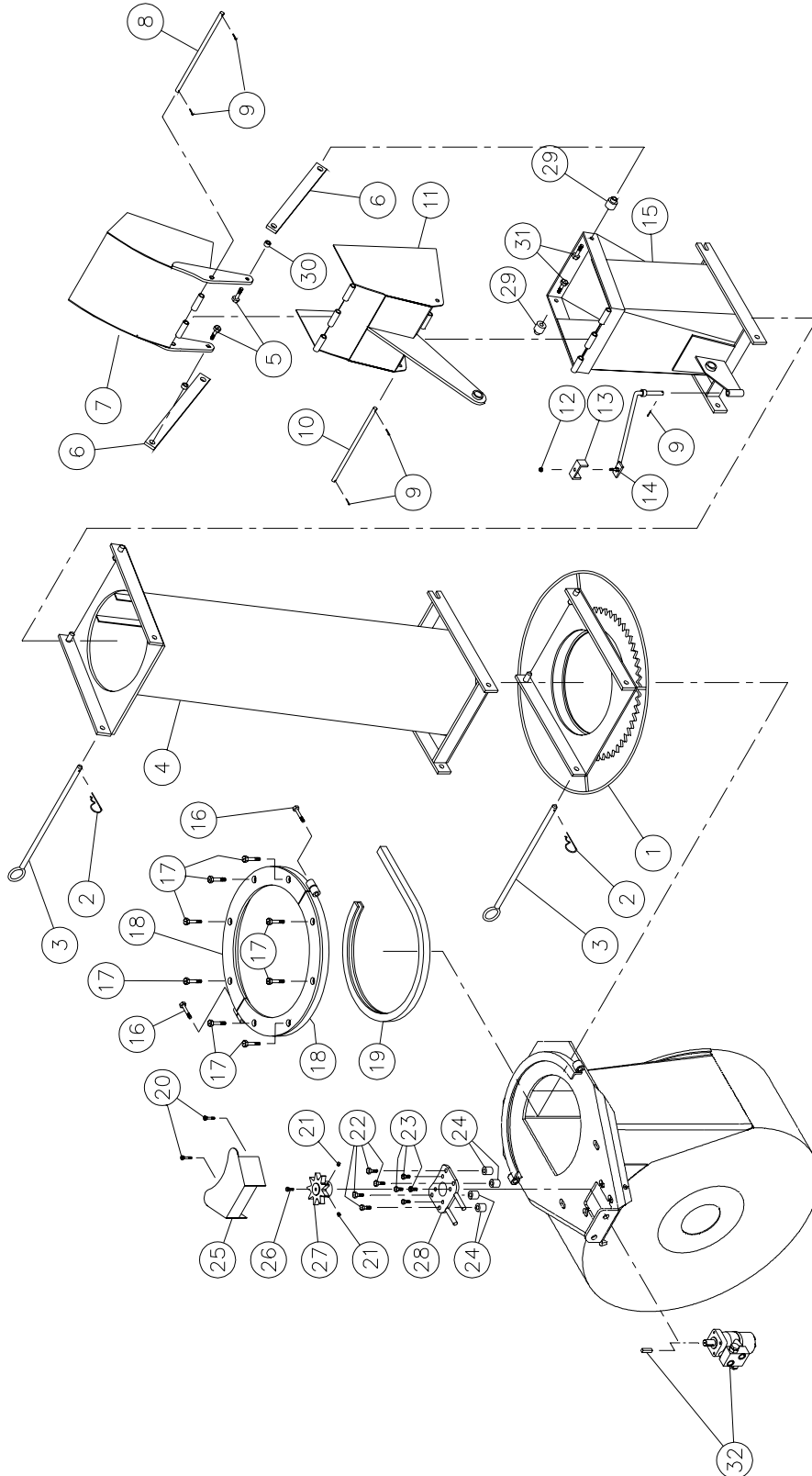

INDUSTRIAL CHUTE PC-92104 (for industrial snowblower)

REF.	PART #	DESCRIPTION	QTY
1	110-00681	Chute adaptor with quick attach	1
2	Std.	Hitch pin clip 5/32"	2
3	9414	Pin for quick attach (adaptor & extension)	2
4	PR-92104-2	Extension 24"	opt.
4	PR-92104	Extension 48"	opt.
5	300-40310	Bolt 1/2" NC x 1 1/4" lg + nylon lock nut & flat washer	2
6	140-11721	Connecting rod	2
7	110-18141	Upper deflector	1
8	9417	Upper deflector pin	1
9	Std.	Cotter pin 1/8" x 1" lg	5
10	9418	Lower deflector pin	1
11	110-18291	Lower deflector	1
12	346-34000	Nylon locknut 5/16" NC	1
13	140-00881	Hoses support plate	1
14	110-01111	Hoses support rod	1
15	110-01541	Chute base	1
16	300-38400	Bolt 7/16" NC x 3" lg + nylon locknut	2
17	300-40400	Bolt 1/2" NC x 3" lg + nylon locknut & 2 flat washers	8
18	110-12351	Retaining bracket	2
19	190-03381	U-shaped UHMW +/- 16" i.d.	1
20	300-34280	Bolt 5/16" NC x 1 1/4" lg + nylon locknut	2
21	323-36160	Hexagonal socket set screw 3/8" NC x 3/8" lg	2
22	300-38370	Bolt 7/16" NC x 2 1/2" lg + nylon locknut & flat washer	4
23	300-36250	Bolt 3/8" NC x 1" lg + lock washer	4
24	160-01331	Spacer 1/2" i.d. x 1" o.d. x 59/64" lg	4
25	130-14281	Guard	1
26	300-32220	Bolt 1/4" NC x 3/4" lg + lock washer	1
27	110-04721	Sprocket (9 teeth)	1
28	110-20811	Orbit motor support + 4 nut 7/16" NC	1
29	150-03871	Spacer for connecting rod (bottom)	2
30	150-03831	Spacer for connecting rod (top)	2
31	300-40370	Bolt 1/2" NC x 3" lg + nylon locknut & flat washer	2
32	MLH315	Orbit hydraulic motor with cushion valve	opt.

HYDRAULIC TELESCOPIC CHUTE PCTH-92104 (for industrial snowblower)

170-02655

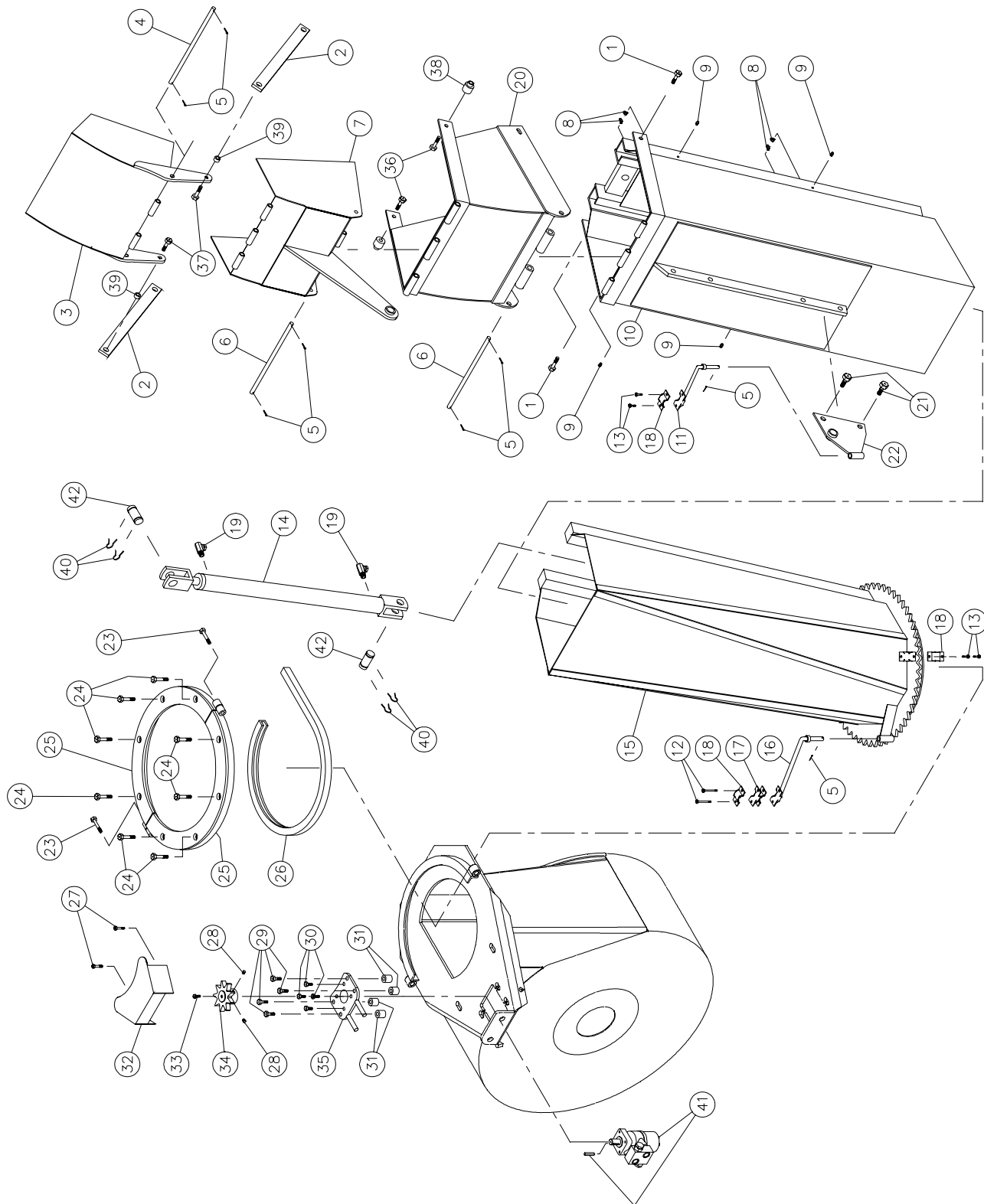

HYDRAULIC TELESCOPIC CHUTE PCTH-92104 (for industrial snowblower)

REF.	PART #	DESCRIPTION	QTY
1	300-40310	Bolt ½" NC x 1 ½ lg + nylon locknut	2
2	140-11721	Connecting rod	2
3	110-04952	Upper chute deflector	1
4	150-01131	Upper chute deflector pin	1
5	Std.	Cotter pin 1/8" x 1" lg	8
6	150-01141	Lower chute deflector pin	2
7	110-04961	Lower chute deflector	1
8	Std.	Grease fitting 1/4" - 28 90°	4
9	Std.	Grease fitting 1/4" - 28 straight	4
10	110-05553	Upper extension	1
11	110-01122	Mounting support plate for upper extension	1
12	300-32370	Bolt 1/4" NC x 2 1/2" lg + nylon locknut	2
13	300-32250	Bolt 1/4" NC x 1" lg + nylon locknut	4
14	20G28	Cylinder 2" x 28" stroke	1
15	110-05563	Lower extension	1
16	110-04982	Mounting support plate for lower extension	1
17	110-20611	Hoses mounting plate	1
18	140-13071	Hoses mounting plate	1
19	9405x6x6	Fitting 3/8" NPT 90 deg. (swivel)	2
20	110-12941	Extension 16"	1
21	300-44340	Bolt 5/8" NC x 2" lg + nylon locknut	2
22	110-11931	Ajustable stanchion for deflector cylinder	1
23	300-38400	Bolt 7/16" NC x 3" lg + nylon locknut	2
24	300-40400	Bolt 1/2" NC x 3" lg + nylon locknut & 2 flat washers	8
25	110-12351	Retaining bracket	2
26	190-03381	U-shaped UHMW +/- 16" i.d.	1
27	300-34280	Bolt 5/16" NC x 1 1/4" lg + nylon locknut	2
28	323-36160	Hexagonal socket set screw 3/8" NC x 3/8" lg	2
29	300-38370	Bolt 7/16" NC x 2 1/2" lg + nylon locknut & flat washer	4
30	300-36250	Bolt 3/8" NC x 1" lg + lock washer	4
31	160-01331	Spacer 1/2" i.d. x 1" o.d. x 59/64" lg	4
32	130-14281	Guard	1
33	300-32220	Bolt 1/4" NC x 3/4" lg + lock washer	1
34	110-04721	Sprocket (9 teeth)	1
35	110-20811	Orbit motor support + 4 nut 7/16" NC	1
36	300-40370	Bolt 1/2" NC x 3" lg + nylon locknut	2
37	319-38310	Plow bolt 7/16" NC x 1 1/4" lg + nylon locknut & flat washer	2
38	150-03871	Spacer for connecting rod (bottom)	2
39	150-03831	Spacer for connecting rod (top)	2
40	Std.	Hair pin 7/8"	4
41	MLH315	Orbit hydraulic motor with cushion valve	opt.
42	6005-1	Pin 1" x 3 1/8" lg	2

LATERAL HYDRAULIC BLADES

170-02693

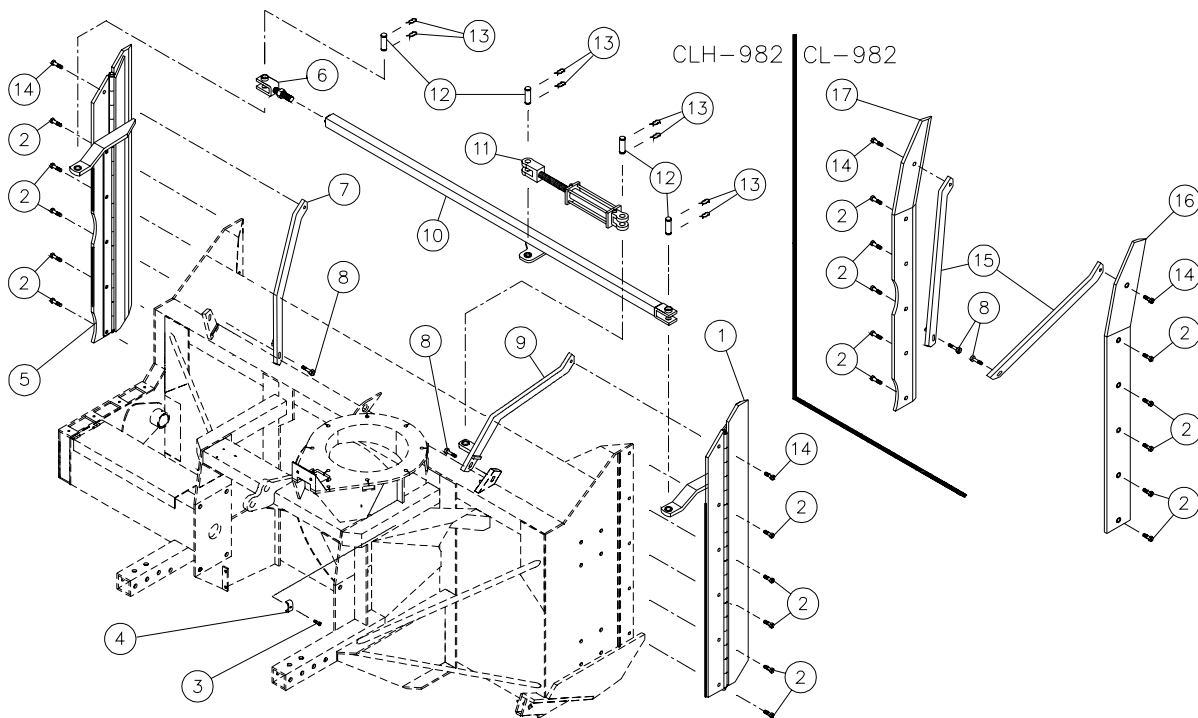

REF.	PART #	DESCRIPTION	CLH-982	CL-982
1	110-14441	Sharpened lateral blade (carbon steel, right side)	1	-
2	319-40325	Plow bolt 1/2" NC x 1 3/4" lg + nut & lock washer	10	10
3	300-34310	Bolt 5/16" NC x 1 1/2" lg	1	-
4	140-00481	Hose clamp	1	-
5	110-15641	Sharpened lateral blade (carbon steel, left side)	1	-
6	110-14121	Main hydraulique ajustable + nut 1"-14 NF	1	-
7	110-14161	Left lateral blade strengthener	1	-
8	300-40370	Bolt 1/2" NC x 2 1/2" lg + nylon locknut & flat washer	2	2
9	110-14151	Right lateral blade strengthener	1	-
10	110-15651	Connecting tube	1	-
11	25TR08	Cylinder 2.5" x 8" stroke	1	-
12	D6005-1	Pin for cylinder 1" x 3 1/8" lg	4	-
13	Std.	Hair pin 7/8"	8	-
14	319-40340	Plow bolt 1/2" NC x 2" lg + nut & lock washer	2	2
15	140-09561	Side strengthener	-	2
16	110-13231	Lateral blade (carbon steel, right side)	-	1
17	110-14701	Lateral blade (carbon steel, left side)	-	1

10

REDUCTION GEAR BOX OPTIONS

170-02681

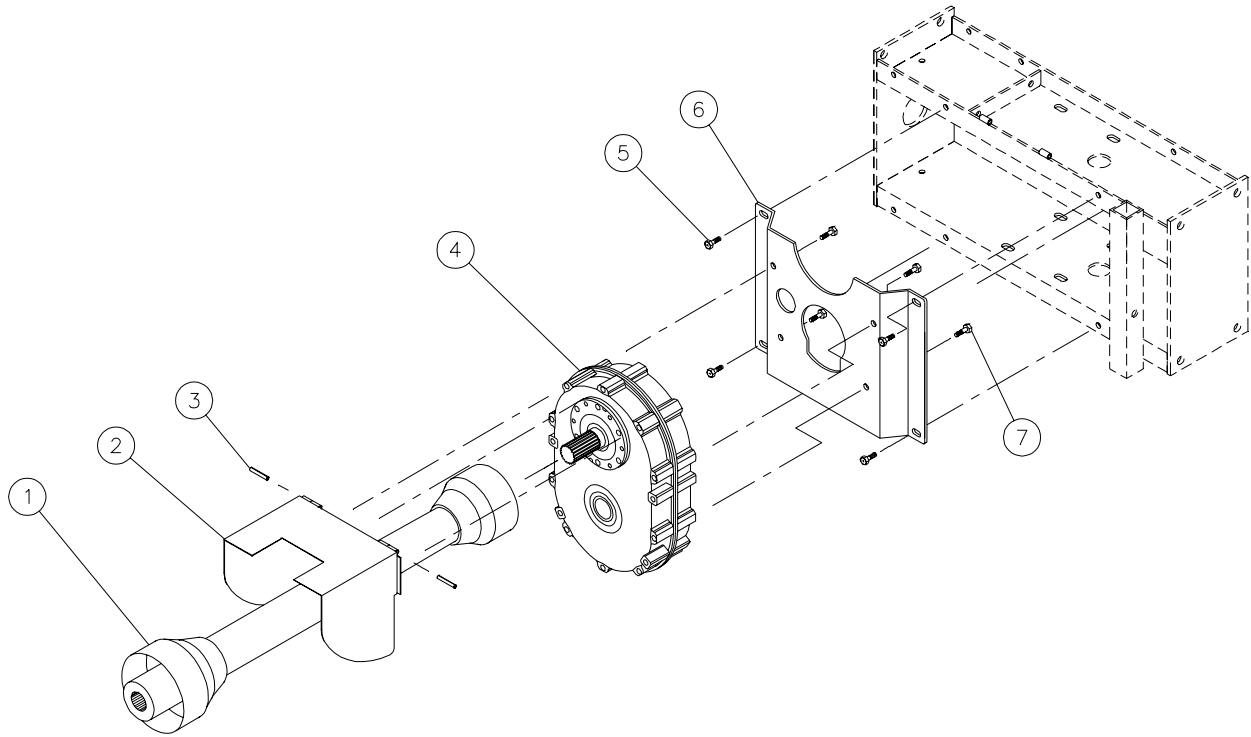

REF.	PART #	DESCRIPTION	QTY		
			PR-91054	PR-91054-180	C3A-91054-200
1	9599	P.T.O. V90 1 3/8"-21 splines	opt.	opt.	opt.
1	9604	P.T.O. V90 1 3/4"-20 splines	opt.	opt.	opt.
2	110-12961	Hinged P.T.O. shroud	1	1	-
NI*	130-26781	Hinged P.T.O. shroud (if equipped with a 3 gears reduction gear box)	-	-	1
NI*	130-26721	Hinged P.T.O. shroud mounting plate (if equipped with a 3 gears reduction gear box)	-	-	1
3	Std.	Roll pin 5/16" x 2" lg	2	2	-
4	9575	Reduction gear box - 3 chains 1000/540 150 HP	1	-	-
4	9609	Reduction gear box - 5 chains 1000/540 180 HP	-	1	-
NI*	9621	Reduction gear box - 3 gears 1000/540 200 HP	-	-	1
5	300-40310	Bolt 1/2" NC x 1 1/2" lg + nylon locknut & flat washer	4	4	4
6	130-19521	Mounting plate for 3 or 5 chains reduction gear box on P-982TRC-150 ...	1	1	-
NI*	110-21441	Mounting box for 3 gears reduction gear box on P-982TRC-150	-	-	1
7	300-40280	Bolt 1/2" NC x 1 1/4" lg + lock washer	4	4	-
NI*	309-40030	Bolt M16-2.0 x 30 mm pl + spring washer 5/8" & flat washer 5/8"	-	-	8
NI*	Std.	Linch pin 1/4" x 1 3/4" lg	-	-	2

*NI = Not illustrated

10

REDUCTION GEAR BOX # 9575 150 HP

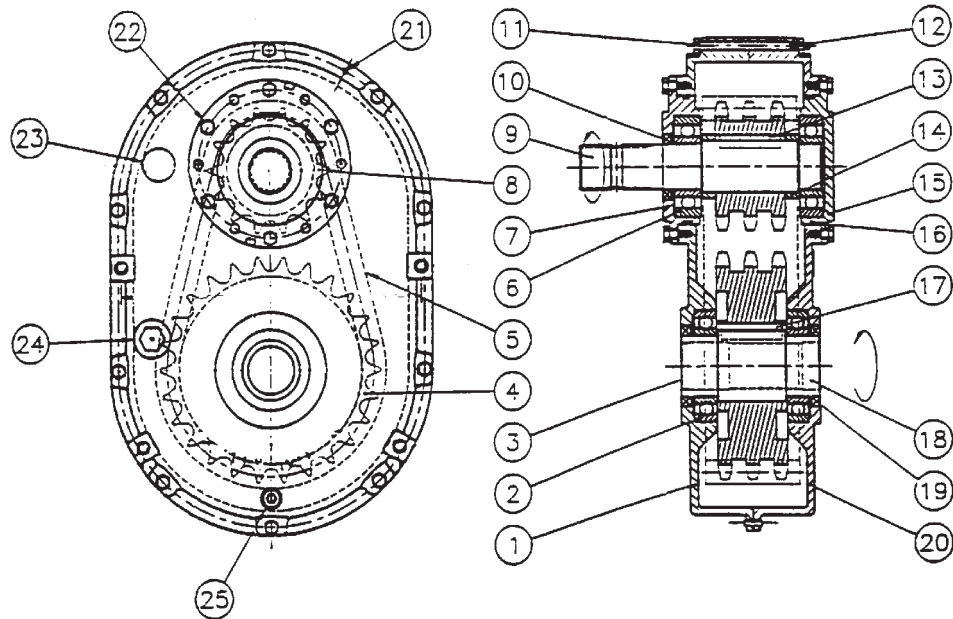

REF.	PART #	DESCRIPTION	QTY
1	9546	Casing with plug	1
2	6212-RS	Bearing 6212	2
3	9547	Seal cover (47 x 7)	1
4	9548	Sprocket 80-3A26	1
5	9549	Chain 80-3 x 36" lg	1
6	6309-RS	Bearing 6309	2
7	9550	Input cover with hole	1
8	9551	Sprocket 80-3A14	1
9	9552	Input shaft 1 3/4"-20 splines	1
10	9553	Oil seal (45x65x8) TC double lips	1
11	Std.	Bolt 5/16" NC x 4 1/2" lg	10
12	Std.	Nut 5/16" NC	10
13	9554	Square key 1/2" x 2 1/2"	1
14	9555	Spacer (2 - 2 3/8 - 0.568)	2
15	9556	Input cover w/o hole	1
16	9557	O-ring AS-248	2
17	9558	Square key 5/8" x 2 1/2"	1
18	9559	Output shaft 1 3/4"-20 splines	1
19	9560	Oil seal (60 x80x10) TC double lips	2
20	9561	Casing w/o plug	1
21	9562	Slotted spring pin 3/16" x 3/4"	2
22	Std.	Bolt 3/16" NC x 3/4" lg	12
23	9563	Air vent 1/2" NPT	1
24	9564	Sight glass 3/4" NPT	1
25	9565	Drain plug 1/2" NPT	1

REDUCTION GEAR BOX # 9609 180 HP

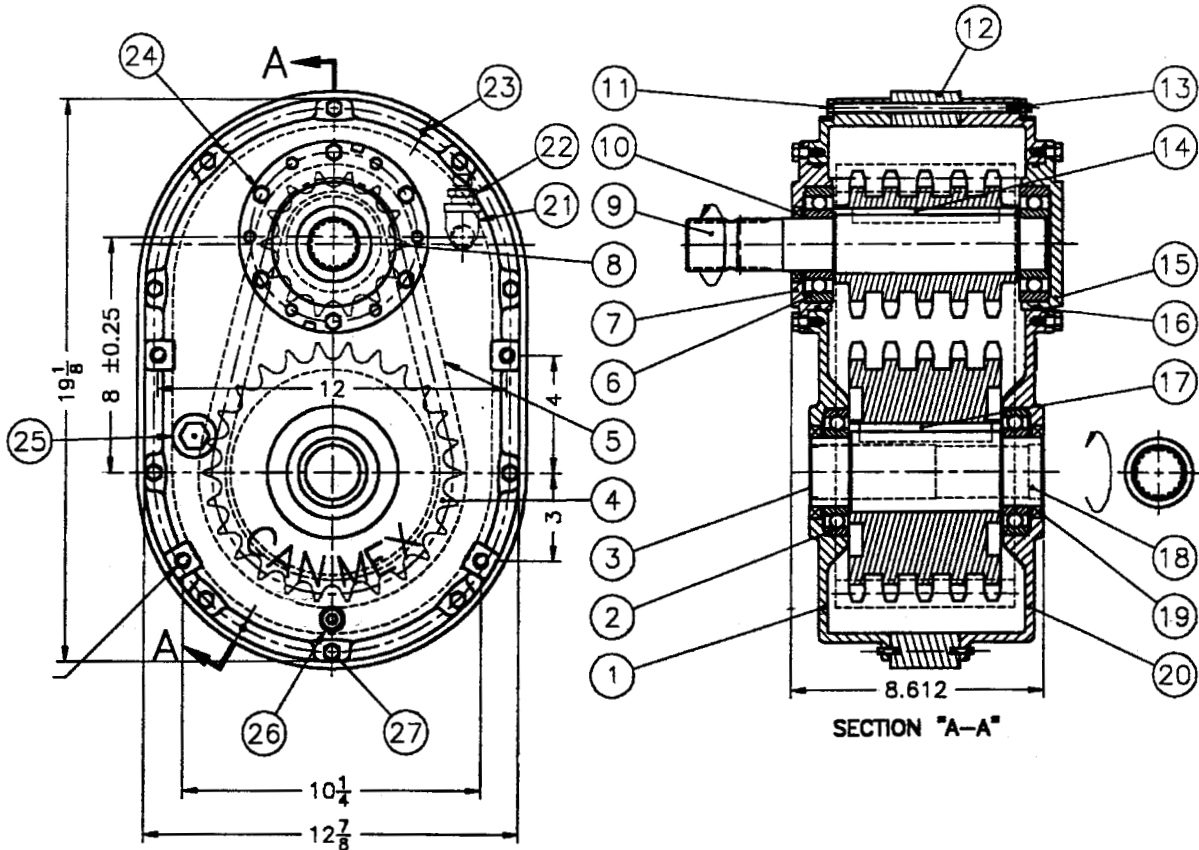

REF.	PART #	DESCRIPTION	QTY
1	9546	Casing with plug	1
2	6212-RS	Bearing 6212	2
3	9547	Seal cover (47 x 7)	1
4	9610	Sprocket 80-5A26	1
5	9611	Chain 80-5 x 36" lg	1
6	6309-RS	Bearing 6309	2
7	9550	Input cover with hole	1
8	9612	Sprocket 80-5C14	1
9	9613	Input shaft 1 3/4"-20 splines	1
10	9553	Oil seal (45 x 65 x 8)	1
11	Std.	Bolt 5/16"-18 UNC x 7	3
12	9614	Spacer	1
13	Std.	Nut 5/16"-8 UNC & lock washer	10
14	9615	Key 1/2" x 5	1
15	9556	Input cover w/o hole	1
16	9557	O-ring AS-248	2
17	9616	Key 5/8" x 4 1/2"	1
18	9617	Output shaft 1 3/4"-20 splines	1
19	9560	Oil seal (60 x 80 x 10) TC double lips	2
20	9561	Casing w/o plug	1
21	9618	Elbow 1/2" 90 deg.	1
22	9563	Air vent 1/2" NPT	1
23	9562	Slotted spring pin 3/16" x 3/4"	2
24	Std.	Bolt 5/16" NC x 3/4" lg & lock washer	12
25	9564	Sight glass 3/4" NPT	1
26	9565	Drain plug 1/2" NPT	1
27	Std.	Bolt 5/16"-18 UNC x 6 3/4" lg	7

10

REDUCTION GEAR BOX # 9621 - 200 HP

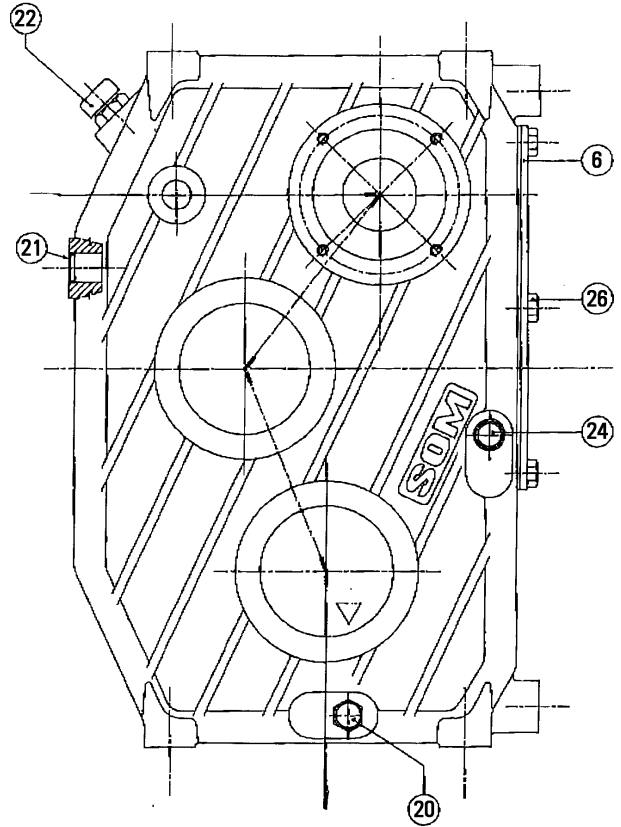
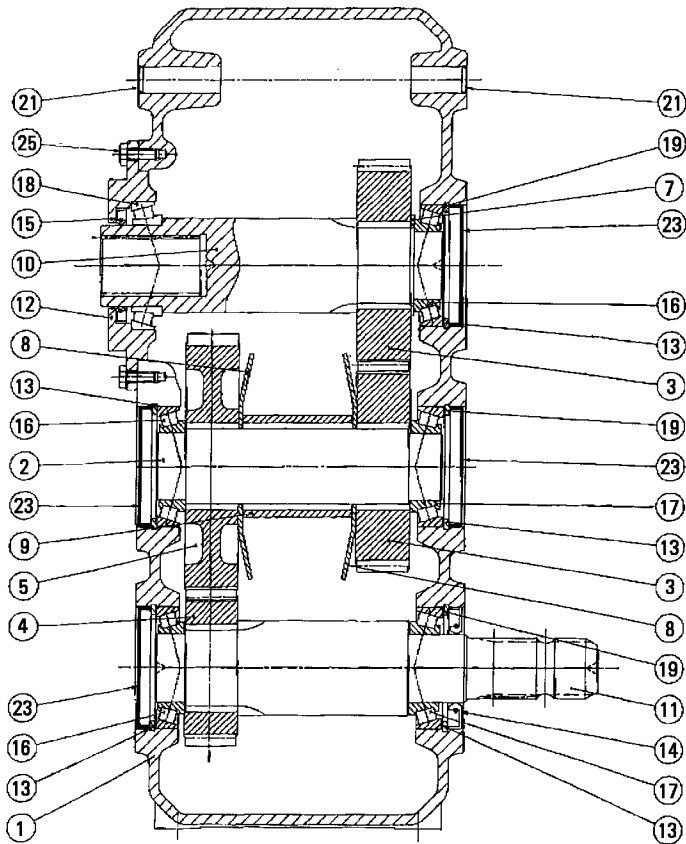

REF.	PART #	DESCRIPTION	QTY
1	9622	Housing	1
2	9623	Shaft	1
3	9624	Ring gear	2
4	9625	Pinion	1
5	9626	Ring gear	1
6	9627	Cover	1
7	9628	Spacer	1
8	9629	Spacer	2
9	9630	Shim	1
10	9631	Output shaft	1
11	9632	Input shaft	1
12	9633	Cover	1
13	9634	Internal snap ring D.90	5
14	9635	Oil seal (50x90x10)	1
15	9636	Oil seal (60x85x8)	1
16	30210-A	Taper roller bearing	3
17	32210-A	Taper roller bearing	2
18	32012X	Taper roller bearing	1
19	9637	Shim kit	3
20	9638	Plug 3/8G	1
21	9639	Plastic plug 20x4	3
22	9640	Plug 1/2G	1
23	9641	Plastic plug 90x10	4
24	9642	Plug 3/8G	1
25	9643	Bolt M8x22	8
26	9644	Bolt M10x16	6

P.T.O. SHAFT # 9598, 9599 & 9604

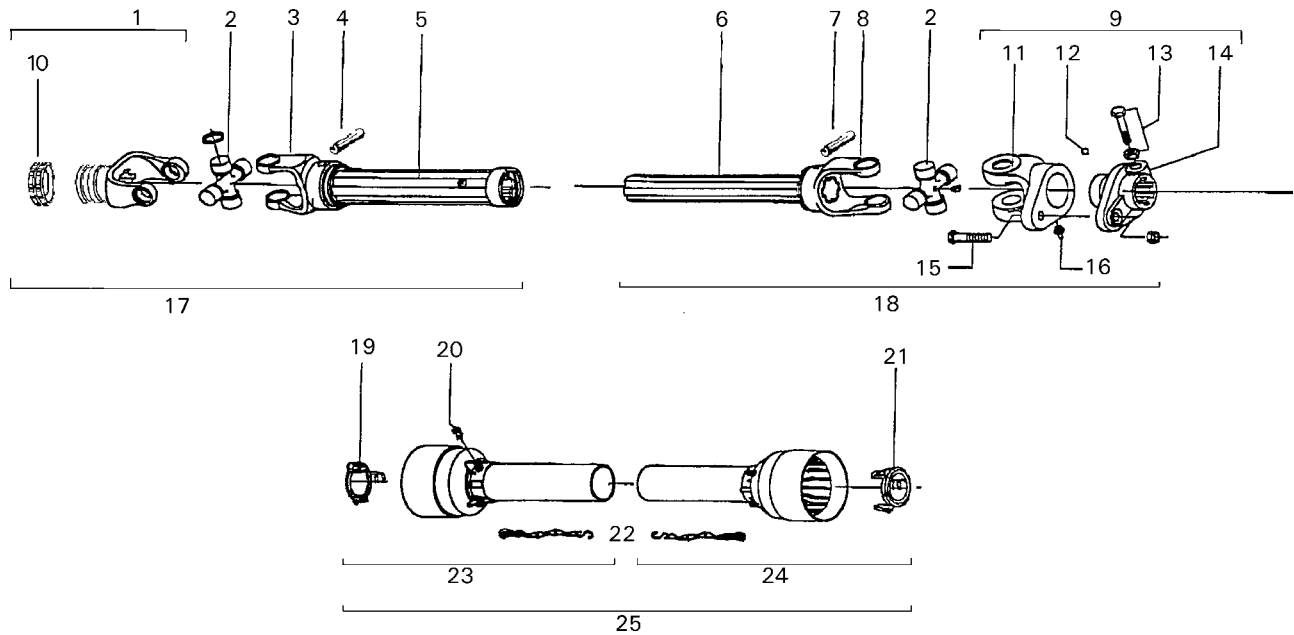

REF.	PART #	DESCRIPTION	9598	9599	9604
1	9481	Yoke with hole 1 3/8" - 6 splines with lock yoke (540 RPM)	1	-	-
1	9482	Yoke with hole 1 3/8" - 21 splines with lock yoke (1000 RPM)	-	1	-
1	9483	Yoke with hole 1 3/4" - 20 splines with lock yoke (1000 RPM)	-	-	1
2	9477	U-joint	2	2	2
3	9600	Yoke for outer tube	1	1	1
4	9210	Stopper for tube	1	1	1
5	9601	Outer tube	1	1	1
6	9602	Inner tube	1	1	1
7	9210	Stopper for tube	1	1	1
8	9603	Yoke for inner tube	1	1	1
9	9476	Safety shear yoke	1	1	1
10	8363	collar kit	1	1	-
10	8364	collar kit	-	-	1
11	9487	Yoke and shearplate M12 x 65	1	1	1
12	9205	Ball 5/16" dia.	24	24	24
13	9461	Bolt + nut M12x1.25x75	2	2	2
14	9486	Adaptor	1	1	1
15	9207	Bolt + nut M12x65	1	1	1
16	8071	Grease fitting	1	1	1
17	9607	P.T.O. section, outer part, without protector, 1 3/8" - 6 splines	1	-	-
17	9607-1	P.T.O. section, outer part, without protector, 1 3/8" - 21 splines	-	1	-
17	9607-2	P.T.O. section, outer part, without protector, 1 3/4" - 20 splines	-	-	1
18	9608	P.T.O. section, inner part, without protector	1	1	1
19	9460	Bearing ring	1	1	1
20	8109	Stopper	6	6	6
21	9459	Bearing ring	1	1	1
22	8308	Safety chain	2	2	2
23	9220	Outer shield	1	1	1
24	9221	Inner shield	1	1	1
25	9222	Complete shield	1	1	1

GEAR BOX # 9307 (T279)

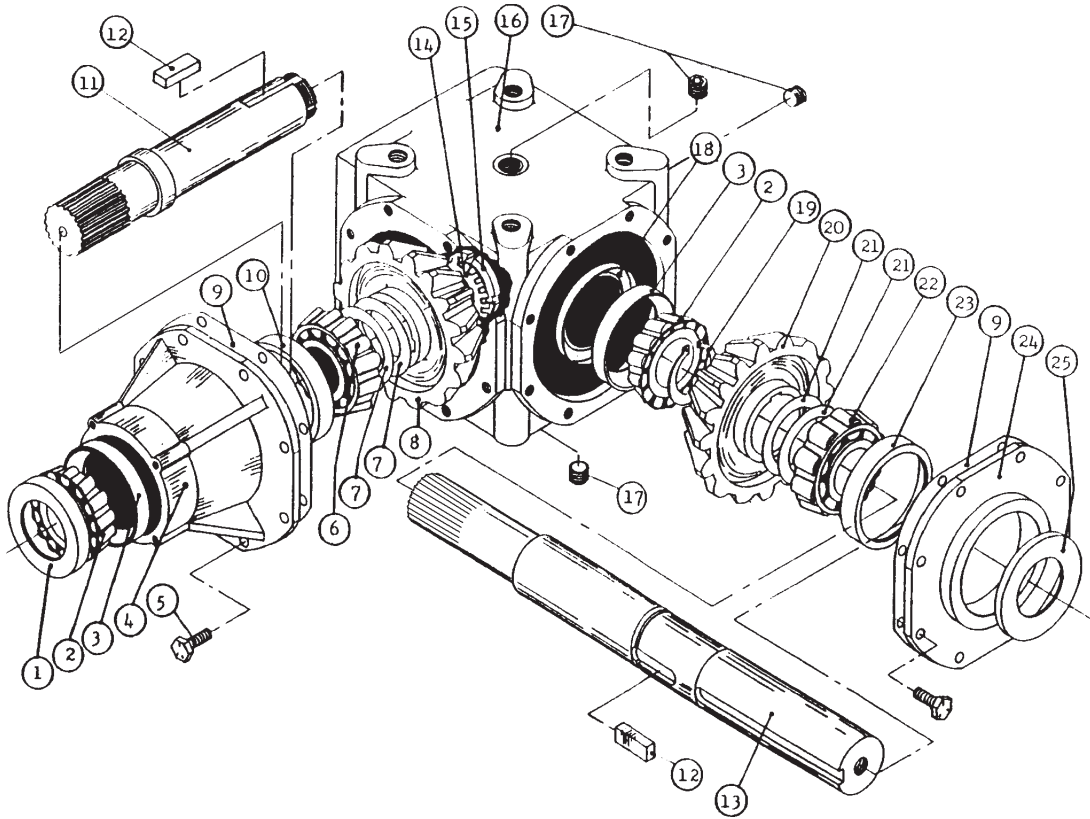

REF.	PART #	DESCRIPTION	QTY
1	6314	Oil seal 52 x 85 x 10	1
2	6315	Bearing 30209: cone	2
3	6317	Bearing 30209: cup	2
4	6318	Extension	1
5	6319	Bolt M10 x 22	16
6	6320	Bearing 32209: cone	1
7	6321	Shim	2
8	6322	Gear Z21	1
9	6323	Gasket	2
10	6324	Bearing 32209: cup	1
11	6325	Side shaft Z20 (1 3/4" - 20 splines)	1
12	6326	Key B14 x 9 x 40	2
13	9345	Impeller shaft (2" & 1 3/4" - 20 splines)	1
14	6328	Spring washer	1
15	6329	Lock nut M40 x 1.5 H9	1
16	6330	Casing	1
17	6331	Plug 3/8" gas	3
18	6332	Dust excluder 45 x 72 x 8	1
19	6333	External circlip 50 UNI7435	1
20	6334	Gear Z21	1
21	6335	Shim	2
22	6336	Bearing 30210: cone	1
23	6337	Bearing 30210: cup	1
24	6338	Cover	1
25	6339	Oil seal 50 x 72 x 8	1
2 + 3	6411	Roller bearing no. 30209	2
6 + 10	6410	Roller bearing no. 32209	1
22 + 23	6412	Roller bearing no. 30210	1

CYLINDER 25TR08

15050

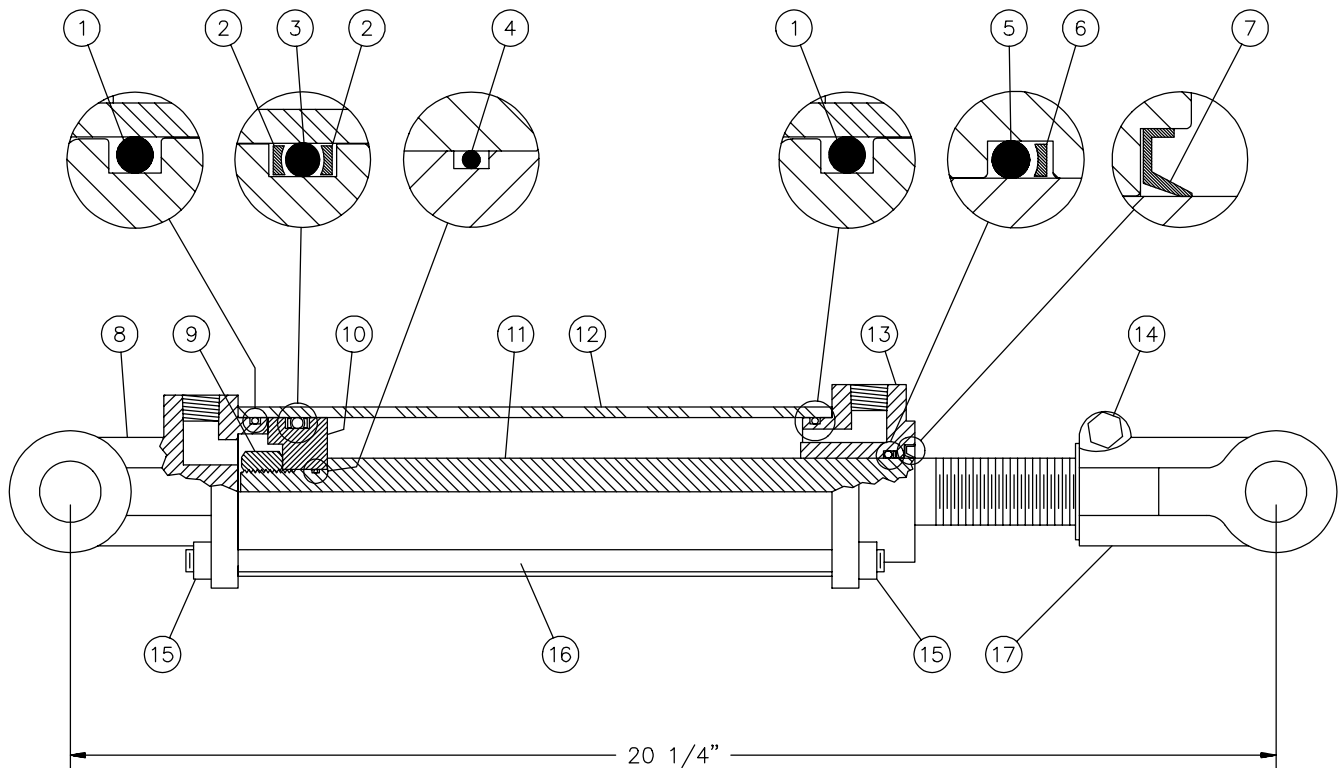

REF.	PART #	DESCRIPTION	QTY
1	See RK25TR	O-ring 1/8" x 2 1/4" x 2 1/2"	2
2	See RK25TR	Back-up 2 1/2" o.d. x 3/16 ø	2
3	See RK25TR	O-ring 3/16" x 2 1/8" x 2 1/2"	1
4	See RK25TR	O-ring 1/16" x 5/8" x 3/4"	1
5	See RK25TR	O-ring 1/8" x 1 1/8" x 1 3/8"	1
6	See RK25TR	Back-up 1 3/8" o.d. x 1/8" ø	1
7	See RK25TR	Wiper 1 1/8" i.d. x 1 5/8" o.d.	1
8	492401	Yoke (for tube 2 1/2")	1
9	Std.	Nut 3/4" NF	1
10	4924-31	Piston 2 1/2" ø	1
11	492028	Piston rod 1 1/8"	1
12	491668	Cylinder body 2 1/2" ø	1
13	492421	Head (for 2 1/2" tube)	1
14	Std.	Bolt 3/8" NC x 2 1/4" + nut	1
15	Std.	Nut 3/8" NC	8
16	Std.	Threaded rod 3/8" NC	4
17	458599	Yoke (for 1 1/8" rod)	1
NI*	8183	Pin 1" ø + cotter pin	2
NI*	RK25TR	Repair kit for cylinder 2 1/2" (includes # 1, 2, 3, 4, 5, 6, & 7)	1

*NI = NOT ILLUSTRATED

CYLINDER # 190-03531 (25TR08 modified)

170-02381

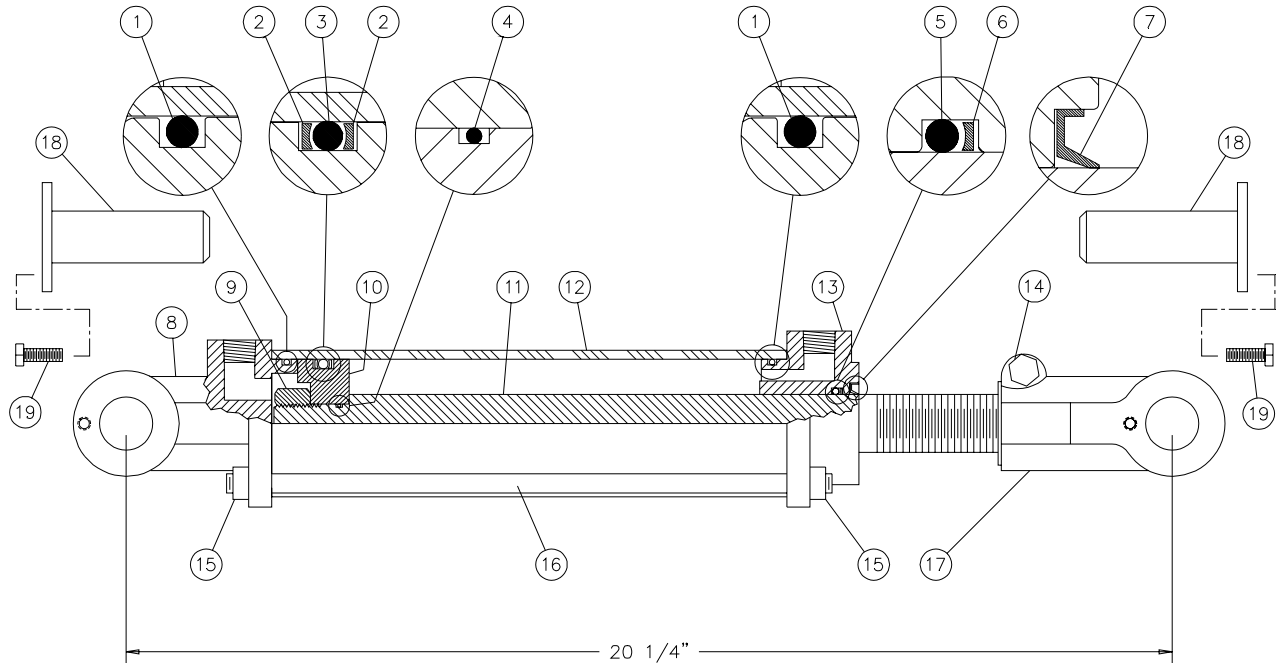

REF.	PART #	DESCRIPTION	QTY
1	See RK25TR	O-ring 1/8" x 2 1/4" x 2 1/2"	2
2	See RK25TR	Back-up 2 1/2" o.d. x 3/16 ø	2
3	See RK25TR	O-ring 3/16" x 2 1/8" x 2 1/2"	1
4	See RK25TR	O-ring 1/16" x 5/8" x 3/4"	1
5	See RK25TR	O-ring 1/8" x 1 1/8" x 1 3/8"	1
6	See RK25TR	Back-up 1 3/8" o.d. x 1/8" ø	1
7	See RK25TR	Wiper 1 1/8" i.d. x 1 5/8" o.d.	1
8	190-03533	Yoke (for 2 1/2" tube)	1
9	Std.	Nut 3/4" NF	1
10	4924-31	Piston 2 1/2" ø	1
11	491980	Piston rod 1 1/8"	1
12	491668	Cylinder body 2 1/2" ø	1
13	492421	Head (for 2 1/2" tube)	1
14	Std.	Bolt 3/8" NC x 2 1/4" lg + nut	1
15	Std.	Nut 3/8" NC	8
16	Std.	Threaded rod 3/8" NC x 12" lg	4
17	190-03532	Yoke (for 1 1/8" rod)	1
18	110-12401	Pin for cylinder 25TR08	2
19	Std.	Bolt 1/4" NC x 3/4" lg + lock washer	2
NI*	8183	Pin 1" ø + cotter pin	2
NI*	RK25TR	Repair kit for cylinder 2 1/2" (includes # 1, 2, 3, 4, 5, 6, & 7)	1

*NI = NOT ILLUSTRATED

CYLINDER 20G28

170-00671

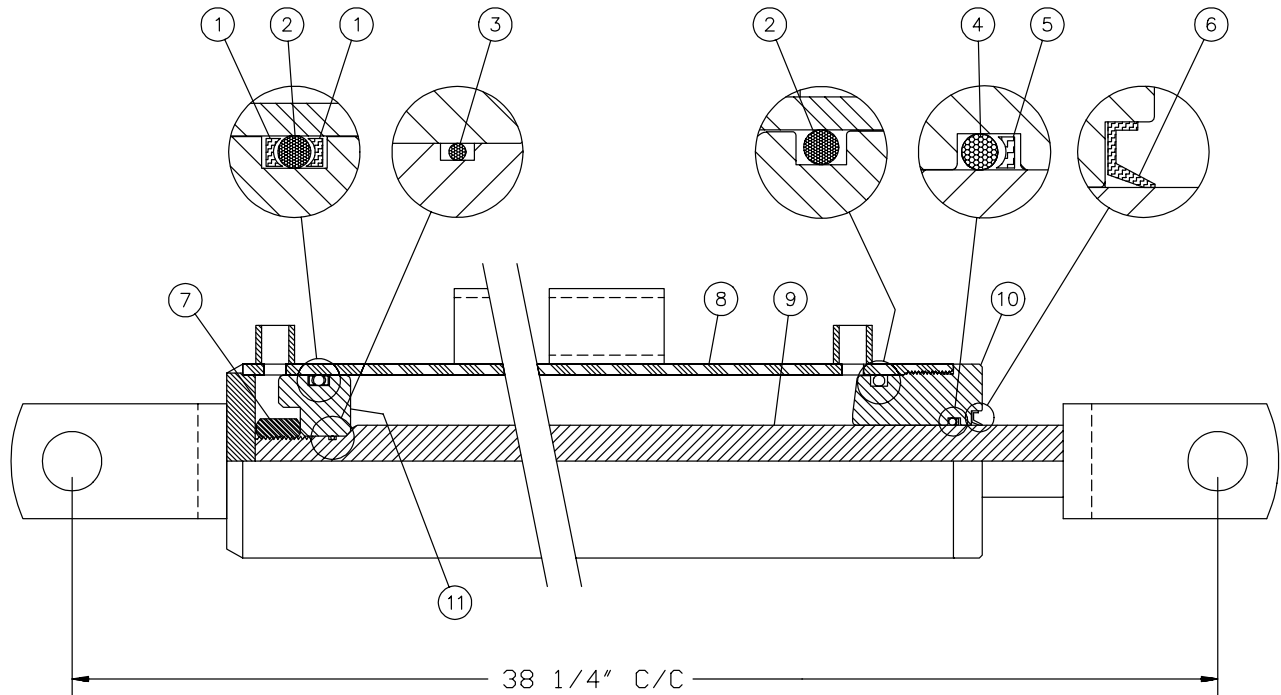

REF.	PART #	DESCRIPTION	QTY
1	BU-326	Back-up 3/16" x 1 5/8" x 2"	2
2	OR-326	O-ring 3/16" x 1 5/8" x 2"	2
3	OR-016	O-ring 1/16" x 5/8" x 3/4"	1
4	OR-216	O-ring 1/8" x 1 1/8" x 1 3/8"	1
5	BU-216	Back-up ring 1/8" x 1 1/8" x 1 3/8"	1
6	CR11050	Wiper 1/8" x 1 1/8" x 1 3/8"	1
7	Std.	Nut 3/4" NF	1
8	110-04491	Cylinder body 2" dia.	1
9	110-04501	Piston rod 1 1/4" dia.	1
10	D-6021	Head 2" dia.	1
11	D-6020	Piston 2" dia.	1
NI*	9488	Repair kit (includes # 1, 2, 3, 4, 5 & 6)	1

*NI = NOT ILLUSTRATED

HYDRAULIC MOTOR # MLH315



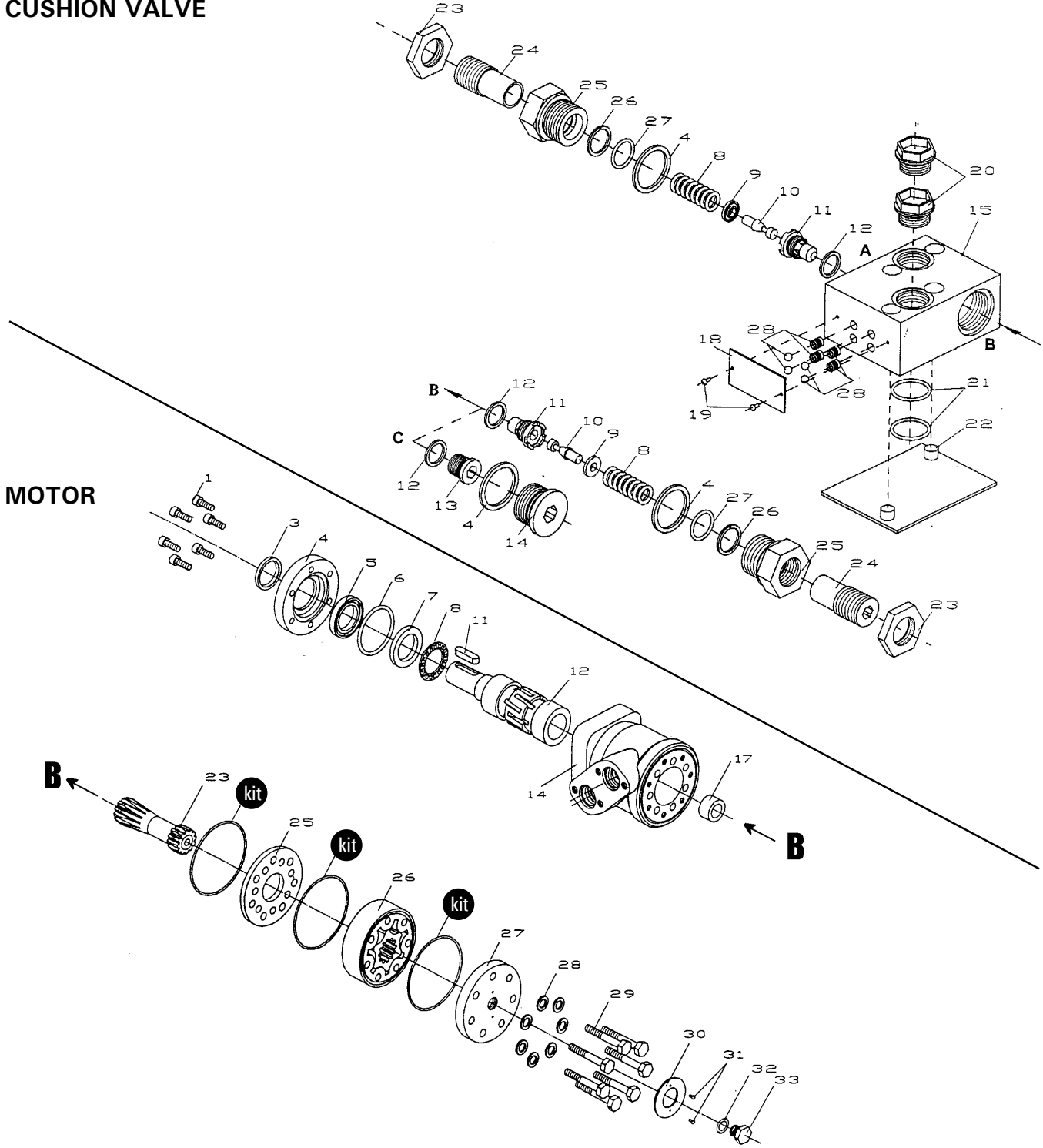



CUSHION VALVE







REF.	PART #	DESCRIPTION	QTY
⊙ kit	8368	Set of seals.....	1
11	8369	Key for "Orbit" motor.....	1

TORQUE CHART

TORQUE SPECIFICATION TABLE

Thread UNC and UNF		Grade 2 				Grade 5   				Grade 8*   			
Bolt size		Torque				Torque				Torque			
Inches	mm	Pound feet min.	Pound feet max.	Newton meters min.	Newton meters max.	Pound feet min.	Pound feet max.	Newton meters min.	Newton meters max.	Pound feet min.	Pound feet max.	Newton meters min.	Newton meters max.
1/4	6.35	5	6	6.8	8.13	9	11	12.2	14.9	12	15	16.3	30.3
5/16	7.94	10	12	13.6	16.3	17	20.5	23.1	27.8	24	29	32.5	39.3
3/8	9.53	20	23	27.1	31.2	35	42	47.5	57.0	45	54	61.0	73.2
7/16	11.11	30	35	40.7	47.4	54	64	73.2	86.8	70	84	94.9	113.9
1/2	12.70	45	52	61.0	70.5	80	96	108.5	130.2	110	132	149.2	179.0
9/16	14.29	65	75	88.1	101.6	110	132	149.2	179.0	160	192	217.0	260.4
5/8	15.88	95	105	128.7	142.3	150	180	203.4	244.1	220	264	298.3	358.0
3/4	19.05	150	185	203.3	250.7	270	324	366.1	439.3	380	456	515.3	618.3
7/8	22.23	160	200	216.8	271.0	400	480	542.4	650.9	600	720	813.6	976.3
1	25.40	250	300	338.8	406.5	580	696	786.5	943.8	900	1080	1220.4	1464.5
1 1/8	25.58	-	-	-	-	800	880	1084.8	1193.3	1280	1440	1735.7	1952.6
1 1/4	31.75	-	-	-	-	1120	1240	1518.7	1681.4	1820	2000	2467.9	2712.0
1 3/8	34.93	-	-	-	-	1460	1680	1979.8	2278.1	2380	2720	3227.3	3688.3
1 1/2	38.10	-	-	-	-	1940	2200	2630.6	2983.2	3160	3560	4285.0	4827.4

* Thick nuts must be used with grade 8 bolts.

Size of screw	Thread	Pitch (mm)	Grade 4T  				Grade 7T 				Grade 8T  			
			Torque				Torque				Torque			
			Pound feet min.	Pound feet max.	Newton meters min.	Newton meters max.	Pound feet min.	Pound feet max.	Newton meters min.	Newton meters max.	Pound feet min.	Pound feet max.	Newton meters min.	Newton meters max.
M6	UNC	1.00	3.6	5.8	4.9	7.9	5.8	9.4	7.9	12.7	7.2	10	9.8	13.6
M8	UNC	1.25	7.2	14	9.8	19	17	22	23	29.8	20	26	27.1	35.2
M10	UNC	1.5	20	25	27.1	33.9	34	40	46.1	54.2	38	46	51.5	62.3
M12	UNC	1.75	28	34	37.9	46.1	51	59	69.1	79.9	57	66	77.2	89.4
M14	UNC	2.0	49	56	66.4	75.9	81	93	109.8	126	96	109	130.1	147.7
M16	UNC	2.0	67	77	90.8	104.3	116	130	157.2	176.2	129	145	174.8	196.5
M18	UNC	2.0	88	100	119.2	136	150	168	203.3	227.6	175	194	237.1	262.9
M20	UNC	2.5	108	130	146.3	176.2	186	205	252	277.8	213	249	288.6	337.4
M8	UNF	1.0	12	17	16.3	23	19	27	25.7	36.6	22	31	29.8	42
M10	UNF	1.25	20	29	27.1	39.3	35	47	47.4	63.7	40	52	54.2	70.5
M12	UNF	1.25	31	41	42	55.6	56	68	75.9	92.1	62	75	84	101.6
M14	UNF	1.5	52	64	70.5	86.7	90	106	122	143.6	107	124	145	168
M16	UNF	1.5	69	83	93.5	112.5	120	138	162.6	187	140	158	189.7	214.1
M18	UNF	1.5	100	117	136	158.5	177	199	239.8	269.6	202	231	273.7	313
M20	UNF	1.5	132	150	178.9	203.3	206	242	279.1	327.9	246	289	333.3	391.6

Use the above torques when special torque is not given.

NOTE: These values apply to fasteners as received from supplier, dry, or when lubricated with normal engine oil. They do not apply if extreme pressure lubricants are used.

WARRANTY

PRONOVOST warrants this product to the initial purchaser for the period of one year from the date of purchase against defects in materials and workmanship.

We will replace or repair defective parts free of charge if they are returned to our plant in St-Tite, Quebec, Canada.

Transportation charges are the responsibility of the customer. This warranty is not transferable.

Hydraulic cylinders and motors are covered by the manufacturer of these items.

All PRONOVOST spare parts purchased are covered by a three (3) month warranty.

This warranty becomes void and nul if the equipment is modified, breaks down as the result of an accident, is not operated according to manufacturer's recommendations, damaged by negligence or if maintenance has not been carried out as specified.

Our obligation is limited to the replacement or repair of the defective part. PRONOVOST accepts no responsibility for direct or indirect consequential damages of any kind.

12

Ce manuel est aussi disponible en français.
Veuillez téléphoner.



INNOVATION - EXCELLENCE

LES MACHINERIES PRONOVOST INC.
260, route 159,
Saint-Tite, Quebec, Canada, G0X 3H0
Tel.: (418) 365-7551, Fax: (418) 365-7954
www.pronovost.qc.ca