



**OPERATOR'S / PARTS  
MANUAL**



***Snowblowers***  
**Models**

**P-740 & P-740TRC**

**P-860 & P-860TRC**

**P-800 & P-800TRC**

**P-862 & P-862TRC**

**P-860-92 & P-860TRC-92**



Copyright © Les Machineries Pronovost Inc., 2010

All rights reserved.  
Printed in Canada.

---



---

# TABLE OF CONTENTS

---

Section	Item	Page
<b>1</b>	<b>Introduction .....</b>	<b>5</b>
<b>2</b>	<b>Safety .....</b>	<b>6</b>
	General Safety .....	6
	Safety in Operation .....	6
	Safety with Maintenance .....	7
	Safety in Transport .....	7
	Safety in Storage .....	7
<b>3</b>	<b>Decals .....</b>	<b>8</b>
	Safety Decals .....	8
	Maintenance Decals .....	12
<b>4</b>	<b>Assembly .....</b>	<b>13</b>
	General assembly .....	13
<b>5</b>	<b>Start-up .....</b>	<b>14</b>
	Basic Start-up Procedures .....	14
<b>6</b>	<b>Maintenance .....</b>	<b>15</b>
	General maintenance .....	15
	Maintenance on speed reducer (with chain) .....	16
<b>7</b>	<b>Storage .....</b>	<b>17</b>
<b>8</b>	<b>Trouble Shooting .....</b>	<b>18</b>
<b>9</b>	<b>Specifications .....</b>	<b>20</b>
<b>10</b>	<b>Parts List .....</b>	<b>21</b>
	Snowblowers P-740 P-800 P-860 P-860-92 .....	21
	Snowblowers P-740TRC P-800TRC P-860TRC P-860TRC-92 .....	24
	Snowblower P-862 .....	28
	Snowblower P-862TRC .....	31
	Chute CST-7486 .....	34
	Semi-industrial Chute PSIG-7486 .....	36
	Industrial Chute PCG-7486 .....	38
	Options .....	40
	P.T.O. Shaft 8114-EG .....	43
	P.T.O. Shaft 8202, 8202-1 .....	44
	P.T.O. Shaft 9225-1 .....	45
	Gear Box 8251 .....	46
	Speed reducer 8348 .....	47
	Cylinder 25TR08 .....	48
	Hydraulic Motor MLH-250 & MLH-315 .....	49
<b>11</b>	<b>Torque Chart .....</b>	<b>50</b>
<b>12</b>	<b>Warranty .....</b>	<b>51</b>



---

---

# INTRODUCTION

---

## CONGRATULATIONS!

Thank you for choosing PRONOVOST. We are confident this equipment will meet your requirements in terms of quality, performance and reliability.

This manual was prepared to assist you in the safe operation of your new Snowblower. It contains important information which will help you achieve excellent returns with your Snowblower for years to come.

Please read this manual completely before operating your Snowblower and keep it for future reference.

Before starting the machine, you or any other person who will be operating the Snowblower must familiarize yourself with the safety recommendations and the operating instructions. Please read carefully and be sure to understand and follow all recommendations and procedures.

In this manual, the right and left sides are identified as shown on Figure 1.

If you require additional information on your Snowblower, please contact your PRONOVOST Dealer.

**NOW** take a moment to enter the model, serial number and the date of purchase of your Snowblower in the space provided.

When ordering parts from your Dealer, please refer to these numbers for a fast and efficient service. Use PRONOVOST parts for replacement.

The model and serial numbers are on the name plate shown on Fig. 1.

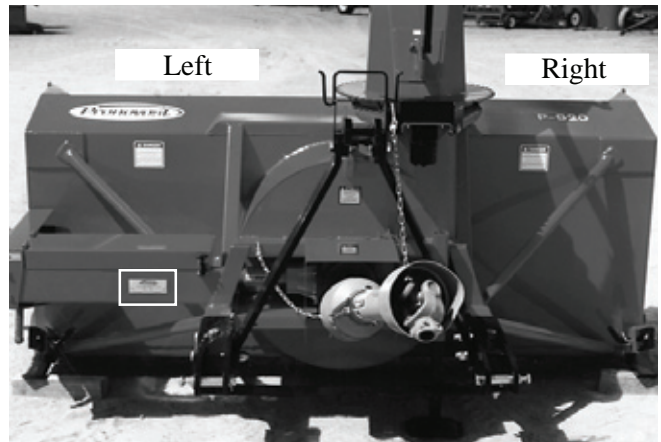

Figure 1

MODEL: \_\_\_\_\_ ✍

SERIAL NO: \_\_\_\_\_ ✍

DATE OF PURCHASE: \_\_\_\_\_ ✍

---

---

# SAFETY

---

## GENERAL SAFETY

2

### WHEN YOU SEE THIS SYMBOL



**ATTENTION!**

**BE ALERT  
YOUR SAFETY IS INVOLVED**

This symbol «SAFETY ALERT» is used in this manual and on the safety decals on the Snowblower. It warns you of the possibility of danger. Carefully read, understand and follow all safety recommendations before operating the Snowblower.

- 1) Careful operation is the best assurance against accidents. Carefully read this manual and follow all recommendations before operating your Snowblower. It is the owner's responsibility to make sure that anyone who will operate the Snowblower will read this manual before operating the equipment.
- 2) Familiarize yourself with all controls and always be ready to stop the Snowblower quickly in case of emergency.
- 3) Never let a child operate the Snowblower.
- 4) Do not modify the Snowblower. Any non authorized modification may affect the efficiency and/or safety of the equipment and will automatically void the warranty.
- 5) Never operate the Snowblower with defective parts or if damaged in any way. Have it repaired before operating.
- 6) Make sure all fasteners are in place and properly secured or tightened. Refer to torque chart on page 50.
- 7) Avoid wearing loose fitting clothing when working with the Snowblower. These could get entangled in moving parts of the equipment and cause accidents.

- 8) Prolonged exposure to noise may hamper hearing. Protect yourself by wearing adequate protection devices.
- 9) Hydraulic fluids under pressure can damage your skin. Do not use your hands to locate a leak.
- 10) Before the beginning of the snow season, inspect all areas where the Snowblower will be used and remove any object which may cause an accident and/or damage the equipment.
- 11) Never operate your Snowblower in poor visibility or without proper lighting conditions.

### SAFETY IN OPERATION

- 1) Be sure there are no obstructions around the equipment and that no one stands near the equipment when in operation.
- 2) Do not operate an engine in a confined or non ventilated area.
- 3) Do not perform any adjustments, cleaning, maintenance or repairs with the engine running. The engine must be stopped and the P.T.O. disengaged. Preferably remove the key from the ignition.
- 4) Wear adequate clothing when working in cold or windy conditions.
- 5) Adjust skid shoes for proper ground clearance of scraper blade, especially in rough terrain or soft ground conditions.
- 6) Before operating, make sure the P.T.O. is properly installed and secured.
- 7) Before starting-up the Snowblower, make sure the auger and drum areas are free of ice.
- 8) Put P.T.O. control in neutral position before starting engine.
- 9) Keep hands, feet and clothing away from moving parts of the Snowblower. Stay away from the discharge chute.

---

---

## ***SAFETY (cont'd)***

---

- 10) Before unplugging the chute, always disengage the P.T.O., stop the engine and relieve all hydraulic pressures.
- 11) Do not operate in excessive inclined conditions. Be careful when turning in slopes.
- 12) Never operate your Snowblower with missing guards or without protective devices in place.
- 13) Do not operate your Snowblower near buildings, windows or other vehicles without prior and proper adjustment of the chute deflector.
- 14) Never aim discharge chute towards people or animals. This may cause serious injuries.
- 15) Always reduce operating speed in slippery conditions.
- 16) Be careful when backing-up, make sure you have good visibility.
- 17) Always be on the lookout for objects which may enter the Snowblower.
- 18) If undue vibrations are felt, disengage the P.T.O., stop the motor and look for the cause of the vibration. Vibration is usually the indication of a problem.
- 19) At the end of the operation, disengage the P.T.O., lower the Snowblower, put transmission in neutral, apply parking brake, stop engine and remove the key from the ignition.

### ***SAFETY WITH MAINTENANCE***

- 1) Perform the Snowblower maintenance according to recommendations contained in this manual.

- 2) Stop engine and relieve all hydraulic pressures before doing inspection, maintenance or repairs.
- 3) Never perform any work under the Snowblower while it is supported only by the tractor's hydraulic system. It must be completely supported by wooden blocks or other safe means.

### ***SAFETY IN TRANSPORT***

- 1) On public roads, use proper safety lights and check local regulations.
- 2) Be alert while driving on the road. Never carry passengers.
- 3) Always disengage P.T.O. while moving from one area of work to another.
- 4) It is recommended to use both brake pedals simultaneously for better control.
- 5) The recommended road speed should be such as to maintain full control over steering and braking.
- 6) Be careful while backing up, make sure you have good visibility.

### ***SAFETY IN STORAGE***

- 1) Provide adequate supports to prevent any accidental overturning of the Snowblower.
- 2) Do not let children play in the area where the snowblower is stored.

**2**

# DECALS

## SAFETY DECALS

The safety decals are affixed wherever special safety precautions are indicated. Locate them on the machine and read them carefully. If a decal is damaged, lost or illegible, install a new one. The following photos indicate where each one must be installed.

3

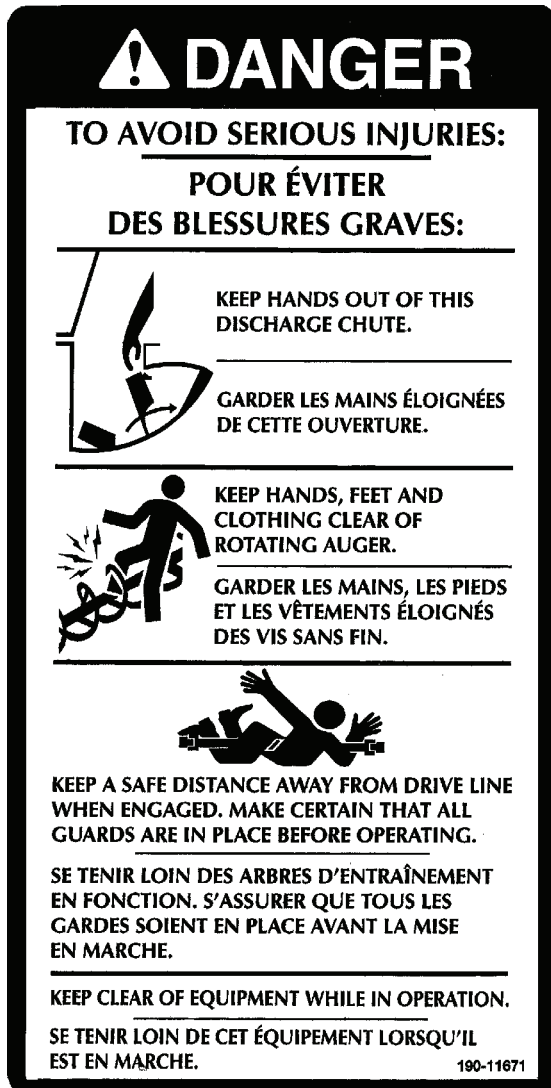

Figure 2  
Decal A

Part no.: 190-11671

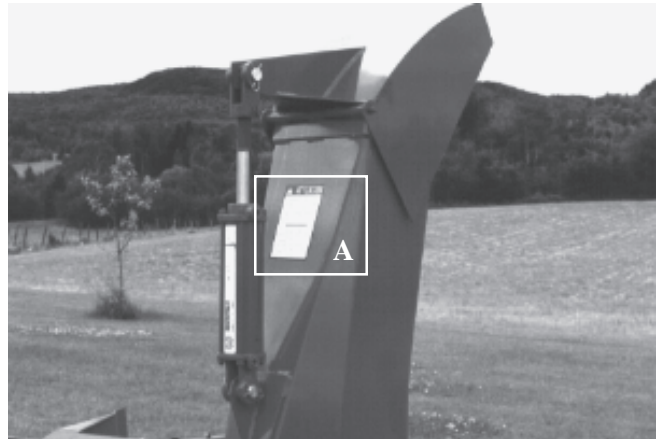

Figure 3

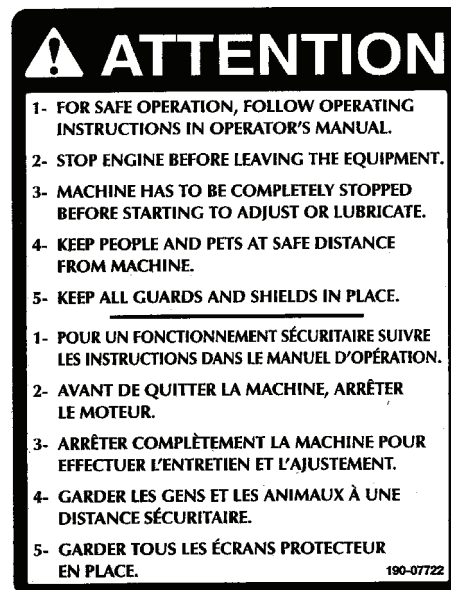

Figure 4  
Decal B

Part no.: 190-07722

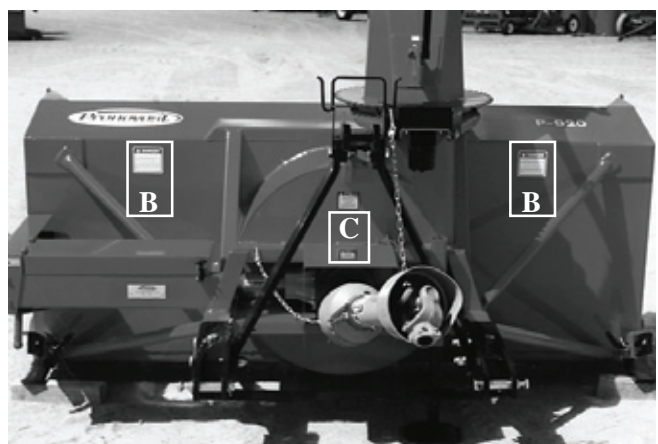

Figure 5



**DECALS (cont'd)**



Figure 6  
Decal C

Part no.: 190-11641

If your snowblower is equipped with a reduction gear box, the decal C will be the one shown below.



Figure 7  
Decal C

Part no.: 190-11651

Decal D in Fig. 8 is located directly on the P.T.O. shaft. It is not visible when the safety shield is in place. It must never be visible when you operate the equipment.



Figure 8  
Decal D

Part no.: A108

**3**

# DECALS (cont'd)

3

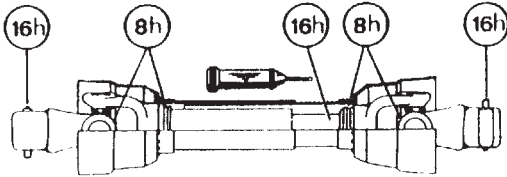

Figure 9  
Decal E Part no.: A 109

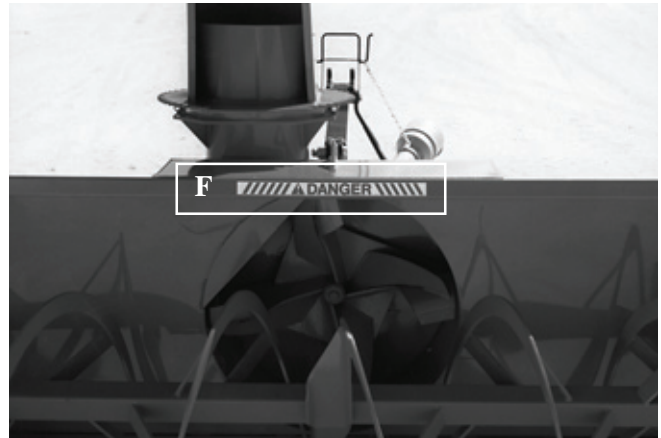

Figure 12



Figure 13  
Decal G Part no.: 190-10991

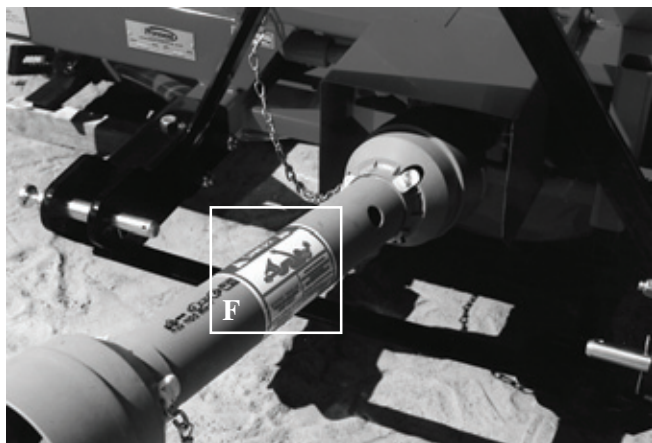

Figure 10



Figure 11  
Decal F Part no.: A103

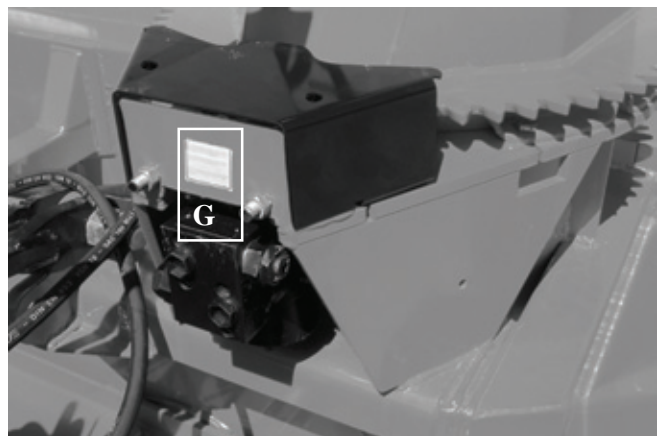

Figure 14

# DECALS (cont'd)

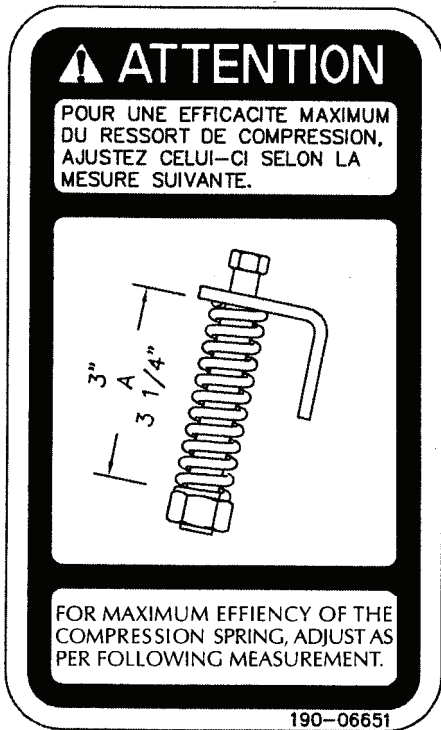

Figure 15  
Decal H

Part no.: 190-06651

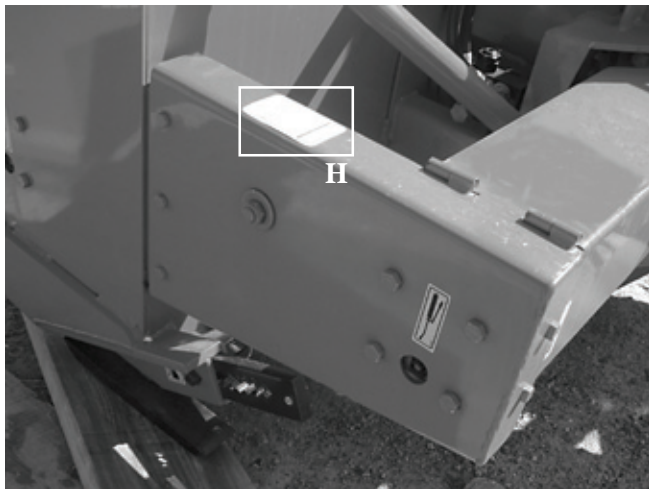

Figure 16

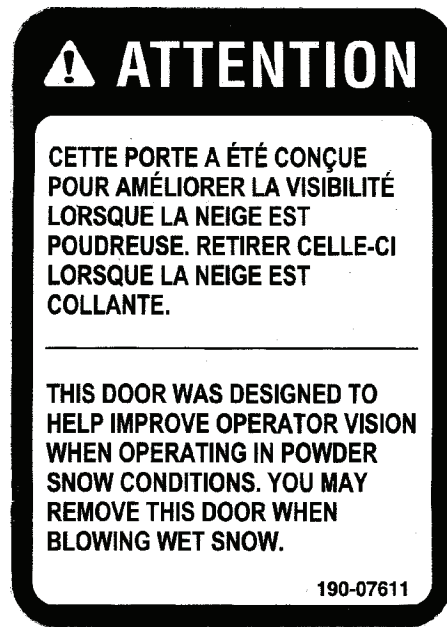

Figure 17  
Decal J

Part no.: 190-07611

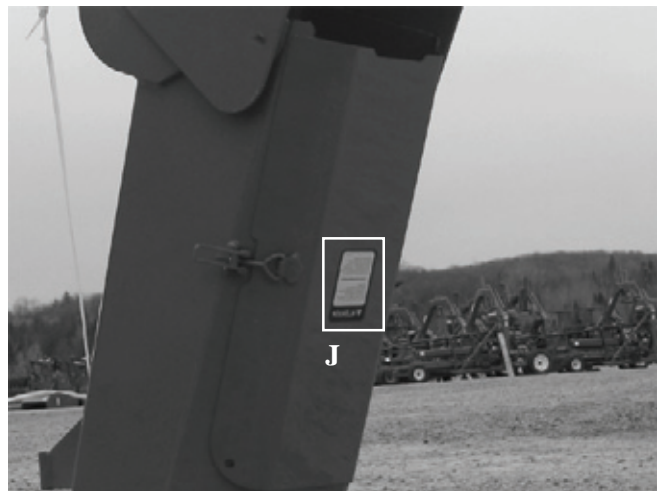

Figure 18

# DECALS (cont'd)

## MAINTENANCE DECALS

The maintenance decals indicate the points requiring lubrication. Refer to maintenance section for more details.

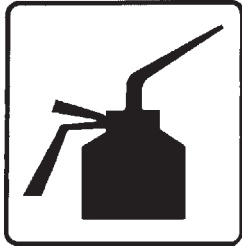

Figure 19

Part no.: A 105



Figure 22

Part no.: A 106

3



Figure 20  
Decal K

Part no.: 190-11591



Figure 23  
Decal L

Part no.: 190-11581

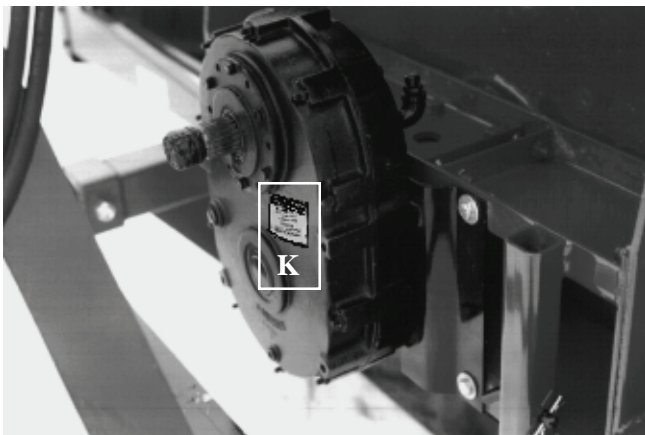

Figure 21

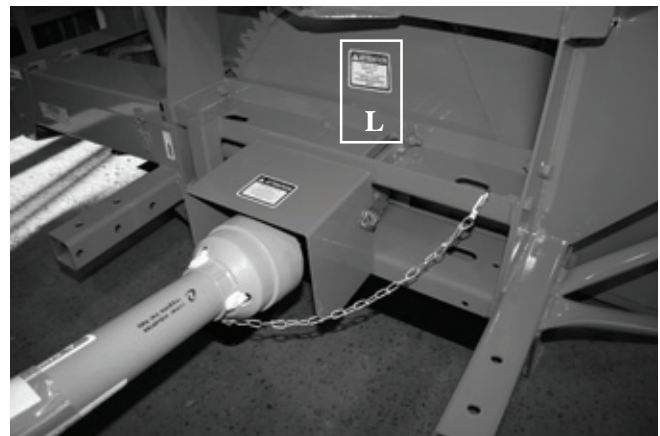

Figure 24

---

# ASSEMBLY

---



Figure 25

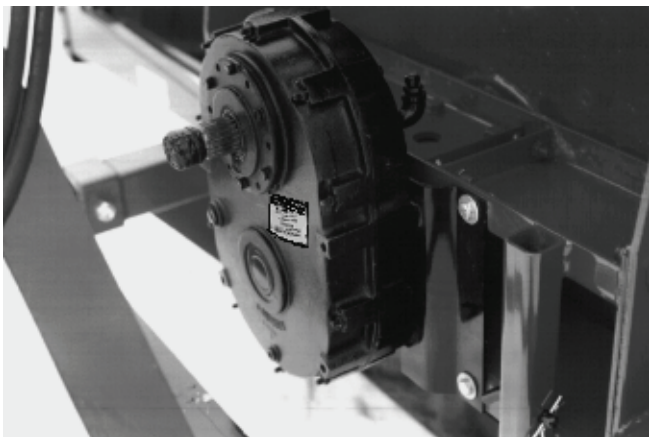

Figure 26

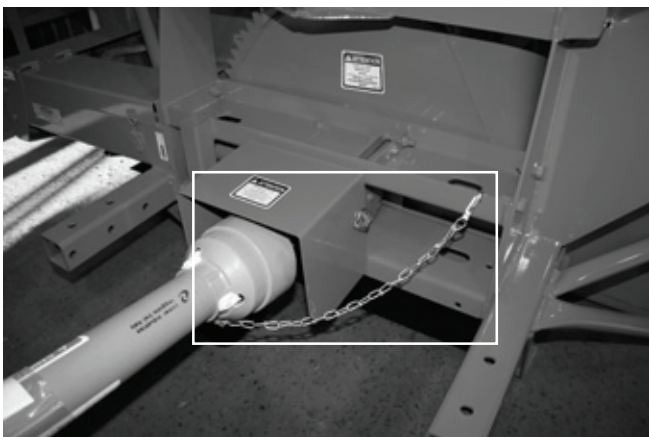

Figure 27

## ASSEMBLY

- 1) The Snowblower is shipped partly assembled.
- 2) Install 3-point system according to the model of your Snowblower. (See section 10 for parts numbers). Use the holes most convenient to the type of tractor used (Fig. 25).
- 3) If your snowblower is equipped with the optional 1000 to 540 RPM reducer, install it on the gear box with the plate included (Fig. 26).
- 4) Install P.T.O. shaft with the shear pin end onto the Snowblower gear box. Then attach safety shield support chain as shown (Fig. 27). **WARNING:** The telescoping tubes of the drive shaft must never be allowed to bottom out while maintaining a minimum overlap of 6 inches.
- 5) If you install a hydraulic cylinder on the chute deflector, use model 25TR08 cylinder.
- 6) When installing chute, grease the groove of the UHMW slide in order to prevent the corrosion of the rim of the chute.
- 7) Install the chute rotation mechanism.

4



---

# STARTING-UP

---

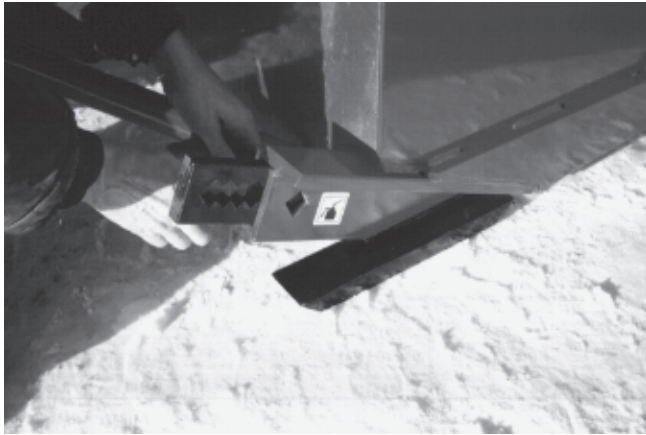

Figure 28

5

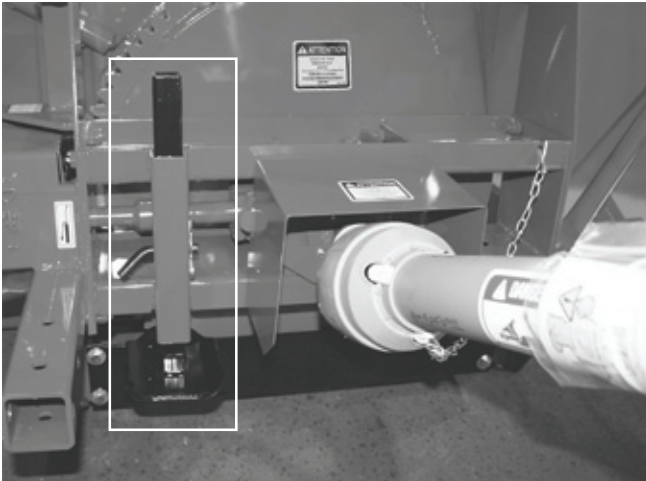

Figure 29



Figure 30

## START-UP PROCEDURES

- 1) Check oil level in gearbox and in speed reducer if so equipped. Adjust to required oil level as per drawing in Parts List section. Use SAE 80W90 oil.
- 2) Lubricate all points with a good quality multipurpose grease.
- 3) Check chain take-up adjustment. The spring maintaining the tension must be compressed to a length between 3" and 3 1/4" (Fig. 15).
- 4) Verify for adequate tightness of all fastening devices. Refer to torque chart on page 50.
- 5) Adjust skid shoes according to ground conditions (Fig. 28).
- 6) Following the installation of the Snowblower on the tractor, **do not forget** to lift the storage support (Fig. 29).
- 7) Make sure of a 540 RPM input to your snowblower.
- 8) Check impeller adjustment. The tip of the blades should be approximately 1/8" to 3/16" from the discharge wall of the drum. If necessary, adjust with the take-up screws provided (Fig. 30).
- 9) In order to avoid damaging your snowblower, adjust the speed of descent of your 3 point hitch to prevent striking the ground too hard.
- 10) Adjust the hydraulic flow in order to have a good control of the rotation speed of the chute.

---

# MAINTENANCE

---

## GENERAL MAINTENANCE

- 1) Wipe off all grease fittings with a clean cloth before adding grease in order to avoid injecting dirt and sand.
- 2) Repair or replace damaged grease fittings.
- 3) Lubricate all grease fittings every 8 hours of operation.
- 4) Oil drive chain every 8 hours of operation.
- 5) Lubricate P.T.O. shaft as indicated below:
- 9) Change gearbox oil once a year. Adjust to required oil level as per drawing in Parts List section. Use SAE 80W90 oil.
- 10) Check all nuts and bolts once a year. If necessary use torque chart on page 50.
- 11) Standard scraper blades are reversible. Reverse when one edge is worn out.
- 12) Always use recommended shear bolts.

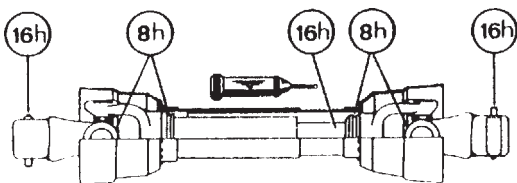

Pull out the P.T.O. and lubricate between the two tubes with low temperature grease. Drive line tubes must slide easily even in cold weather. Clean off old hardened grease and apply fresh grease as needed.

- 6) Check oil level in gear box once a month. Adjust to required oil level as per drawing in Parts List section. Use SAE 80W90 oil.
- 7) Check tension of drive chain every 24 hours of operation and adjust if necessary.
- 8) Check for tightness of bearing collars every 48 hours of operation.
- 13) UHMW slides do not require lubrication except at the end of the season in order to prevent corrosion of steel components that are in contact with the UHMW material.
- 14) After 10 working hours, the chain's adjustment (if applicable) must be checked and every 100 working hours. Please refer to section: Maintenance on Speed Reducer (with chains).
- 15) Check oil level in speed reducer once a month. Adjust to required oil level as per drawing in Parts List section. Use SAE 80W90 oil.
- 16) Drain the oil of the speed reducer once a year. Adjust to required oil level as per drawing in Parts List section. Use SAE 80W90 oil.

### If your snowblower is equipped with the optional speed reducer

6

---

---

## ***MAINTENANCE (cont'd)***

---

### ***MAINTENANCE ON SPEED REDUCER (with chain)***

It is extremely important that the chain inside the chain box is **tightened**. A loose chain will add shocks to the entire box (chain, sprockets, bearings and spline couplings to gearbox).

#### **Instructions for speed reducer (with chains) maintenance**

This chain box has double functions.

- 1) Reduce angles at both ends of PTO in working position by increasing the input shaft height of 8".
- 2) Increase PTO capacity by increasing speed from 540 RPM to 1000 RPM.

#### ***ADJUSTMENT OF THE CHAIN'S TENSION***

After 10 working hours, the chain's adjustment must be checked. In order to do so, verify the backlash between the input and the output shaft by turning the input shaft in both directions while the output shaft remains still. If there is a play of 10° or more, the chain must then be readjusted as follows:

- 1) Remove PTO from the chain box.
- 2) Unscrew the 12 bolts 5/16" dia. (item #22) from covers (items #7 and #15) around the input shaft on both sides of the chain box (6 bolts on each side).

**NOTE:** Input shaft covers are eccentric with outside of covers. Therefore by turning input shaft cover, center to center distance of shafts will be changed and thus, this will adjust the chain's tension.

- 3) With a hammer and a screw-driver or a chisel, gently turn both covers in the same direction until the next hole of the cover is in line with the threaded hole of the chain box.

**IMPORTANT: Make sure that the covers are turned in the same direction and by the same number of holes.**

**Otherwise, both shafts will not be parallel and serious damages might arise.**

- 4) Verify the backlash between both shafts, as described above. If the difference is too high, repeat the operation explained in point 3. If the backlash is correct, reinstall the bolts and the PTO.
- 5) Verify the backlash every 100 working hours.

#### ***MAINTENANCE ON SPEED REDUCER***

- 1) Check oil level in speed reducer once a month. Adjust to required oil level as per drawing in Parts List section. Use SAE 80W90 oil.
- 2) Drain the oil of the speed reducer once a year. Adjust to required oil level as per drawing in Parts List section. Use SAE 80W90 oil.

**6**



---

---

## ***STORAGE***

---

- 1) Store the Snowblower in a cool, dry place.
- 2) Support the Snowblower with wooden blocks.
- 3) Keep all piston rods in the retracted position. This will assure better protection against the elements.
- 4) Clean your Snowblower.
- 5) Thoroughly inspect all parts of the Snowblower. Replace or repair worn or defective parts.
- 6) Touch-up or repaint if necessary.
- 7) Lubricate all points before storage.

# TROUBLESHOOTING

## P.T.O. SHAFT

PROBLEM	POSSIBLE CAUSE	CORRECTION
<ul style="list-style-type: none"> <li>- Premature wear of U-joints and/ or bluish color of cross journals.</li> </ul>	<ul style="list-style-type: none"> <li>- Insufficient lubrication.</li> <li>- Excessive working angle.</li> </ul>	<ul style="list-style-type: none"> <li>- Follow lubrication recommendations.</li> <li>- Replace defective U-joints.</li> <li>- Make sure the snowblower inlet face is perpendicular to the ground and if possible readjust 3-point hitch in order to position the snowblower further away from tractor.</li> </ul>
<ul style="list-style-type: none"> <li>- Gripping or premature wear of telescoping members.</li> </ul>	<ul style="list-style-type: none"> <li>- Too much sliding under load.</li> <li>- Tube overlap too-short: minimum recommended is 6".</li> <li>- Insufficient lubrication.</li> <li>- Contaminants (sand, etc.).</li> </ul>	<ul style="list-style-type: none"> <li>- Avoid raising snowblower while in operation.</li> <li>- Readjust 3-point hitch in order to position the snowblower closer to the tractor.</li> <li>- Follow lubrication recommendations.</li> <li>- Replace defective telescopic members.</li> </ul>
<ul style="list-style-type: none"> <li>- Damaged or jammed locking pin or bolt.</li> </ul>	<ul style="list-style-type: none"> <li>- Pin or orifice contaminated by sand, ice, etc.</li> <li>- Telescoping members too long, exerting pressure on locking device.</li> </ul>	<ul style="list-style-type: none"> <li>- Clean and grease.</li> <li>- Readjust 3-point hitch in order to position the snowblower further away from tractor.</li> </ul>
<ul style="list-style-type: none"> <li>- Premature wear of guard tube bearing ring.</li> </ul>	<ul style="list-style-type: none"> <li>- Lack of lubrication.</li> <li>- Wrong installation of guard chain.</li> <li>- Part of the guard in contact with the equipment.</li> </ul>	<ul style="list-style-type: none"> <li>- Follow lubrication instructions.</li> <li>- Adjust chain to prevent interference between guard &amp; equipment.</li> <li>- Replace worn or damaged bearing rings.</li> </ul>
<ul style="list-style-type: none"> <li>- Cut or deformed safety guard tubes.</li> </ul>	<ul style="list-style-type: none"> <li>- Tubes in contact with the equipment.</li> </ul>	<ul style="list-style-type: none"> <li>- Eliminate any interference between tubes and equipment or tractor.</li> <li>- Replace damaged tubes.</li> </ul>

# ***TROUBLESHOOTING (cont'd)***

## ***SNOWBLOWER***

<b>PROBLEM</b>	<b>POSSIBLE CAUSE</b>	<b>CORRECTION</b>
- The snow is not being thrown as far as usual.	- Tractor RPM too low. - Gap too wide between impeller blade tip and drum outlet wall. - Insufficient tractor HP.	- Raise P.T.O. speed to a minimum of 540 RPM. - Adjust impeller blades closer to drum outlet (1/8" to 3/16"). - Reduce travel speed.
- Frequent plugging of discharge chute.	- Tractor RPM too low. - Tractor RPM reduced too early with snow still in the Snowblower. - Slippage of PTO clutch mechanism. - Wet snow condition.	- Raise P.T.O. speed to a minimum of 540 RPM. - Make sure the Snowblower is completely empty before reducing RPM, especially on tractors with foot controlled RPM. - Repare clutch. - Reduce travel speed. - Remove access panel.
- The impeller will not turn.	- Shear bolt broken on drive shaft.	- Replace shear bolt.
- The auger will not turn.	- Shear bolt broken on drive shaft. - Shear bolt broken on auger drive shaft. - Broken drive chain.	- Replace shear bolt. - Replace shear bolt. - Fix or replace chain.
- The rotating drum will not turn.	- Ice accumulation. - Wrong hydraulic connections.	- Remove ice. - Check hydraulic connections.
- The rotating drum will not hold it's position when blowing via the spout	- Cushion valve setting too low - Tension of the spring in drum locking mechanism insufficient	- Reset cushion valve up to 1800 psi (max) - Increase tension of spring by adding shim(s)
- The chute will not turn.	- Ice accumulation. - Wrong hydraulic connections.	- Remove ice. - Check hydraulic connections.

# SPECIFICATIONS

		GROUP II				
Snowblower model		P-740	P-800	P-860	P-862	P-860 -92
Snowblower model		P-740 TRC	P-800 TRC	P-860 TRC	P-862 TRC	P-860 TRC-92
Horse power recommended (HP) min - max		35-65	40-65	50-75	50-75	50-75
Working width po. - (cm)		74" (188)	80" (203)	86" (218)	86" (218)	92" (234)
Cutting height po. - (cm)		34" (86.5)	34" (86.5)	36" (91.5)	41½" (105.5)	36" (91.5)
Height - Chute base po. - (cm)		37 ¾" (94.9)	37 ¾" (94.9)	39 ¾" (100.0)	39 ¾" (100.0)	39 ¾" (100.0)
Height - chute base, TRC model po. - (cm)		40 11/16" (103.4)	40 11/16" (103.4)	42 11/16" (108.4)	42 11/16" (108.4)	42 11/16" (108.4)
Impeller diameter po. - (cm)		26" (66)	26" (66)	28" (71)	28" (71)	28" (71)
Depth of drum po. - (cm)		12" (30.5)	12" (30.5)	12" (30.5)	12" (30.5)	12" (30.5)
Impeller blades		4	4	4	4	4
Size of impeller shaft po. - (cm)		1 9/16" (3.97)	1 9/16" (3.97)	1 9/16" (3.97)	1 9/16" (3.97)	1 9/16" (3.97)
Height - Impeller center po. - (cm)		16½" (41.9)	16½" (41.9)	17½" (44.5)	17½" (44.5)	17½" (44.5)
Impeller RPM		540	540	540	540	540
Number of augers		1	1	1	2	1
Main auger diameter po. - (cm)		23" (58)	23" (58)	23" (58)	23" (58)	23" (58)
Upper auger 13"/33 cm dia.		-	-	-	Std.	-
Drive chain - main auger		80	80	80	80	80
Oil bath sealed gear box		Std.	Std.	Std.	Std.	Std.
Chute rotation mechanism	Manual	-	-	-	-	-
	Hydraulic (motor)	Std.	Std.	Std.	Std.	Std.
Number of shear bolts		2	2	2	2	2
Hitch category		1&2	1&2	1&2	1&2	1&2
Balanced impeller		Std.	Std.	Std.	Std.	Std.
Balanced auger		Std.	Std.	Std.	Std.	Std.
Drum rotation for hydraulic motor		Std.	Std.	Std.	Std.	Std.
1000 to 540 RPM reducer		Opt.	Opt.	Opt.	Opt.	Opt.
Scraper blades	Standard steel - rev.	Std.	Std.	Std.	Std.	Std.
	Carbon steel 1/2" x 4"	Opt.	Opt.	Opt.	Opt.	Opt.
	Carbon steel 1/2" x 6"	Opt.	Opt.	Opt.	Opt.	Opt.
	Tivar	Opt.	Opt.	Opt.	Opt.	Opt.
	Stainless steel 1/2" x 4"	Opt.	Opt.	Opt.	Opt.	Opt.
Adjustable skid shoes	Standard steel	Std.	Std.	Std.	Std.	Std.
	Carbon steel	Opt.	Opt.	Opt.	Opt.	Opt.
	Stainless steel	Opt.	Opt.	Opt.	Opt.	Opt.
Full flight auger (industrial)		Opt.	Opt.	Opt.	Opt.	Opt.
Chute	regular	Opt.	Opt.	Opt.	Opt.	Opt.
	semi-industrial	Opt.	Opt.	Opt.	Opt.	Opt.
	quick attach indust.	Opt.	Opt.	Opt.	Opt.	Opt.
	- extension 24" or 48"	Opt.	Opt.	Opt.	Opt.	Opt.
	industrial telescopic	-	-	-	-	-
Deflector	manual	Opt.	Opt.	Opt.	Opt.	Opt.
	hydraulic	Opt.	Opt.	Opt.	Opt.	Opt.
Bearing / ductile iron casting		Std.	Std.	Std.	Std.	Std.
Lateral blades		Opt.	Opt.	Opt.	Opt.	Opt.
P.T.O.	(standard)	No. 5	No. 5	No. 6	No. 6	No. 6
P.T.O.	(optional)	No. 6	No. 6	No. 8	No. 8	No. 8
Weight lbs - (kg)		1190 (540)	1235 (561)	1294 (572)	1475 (670)	1344 (610)
		1330 (599)	1372 (617)	1432 (644)	1609 (724)	1482 (674)

Design and specifications subject to change without notice.

Shaded lines apply only to models with rotary drum (TRC).

# SNOWBLOWERS P-740 P-800 P-860 P-860-92

170-03733R1

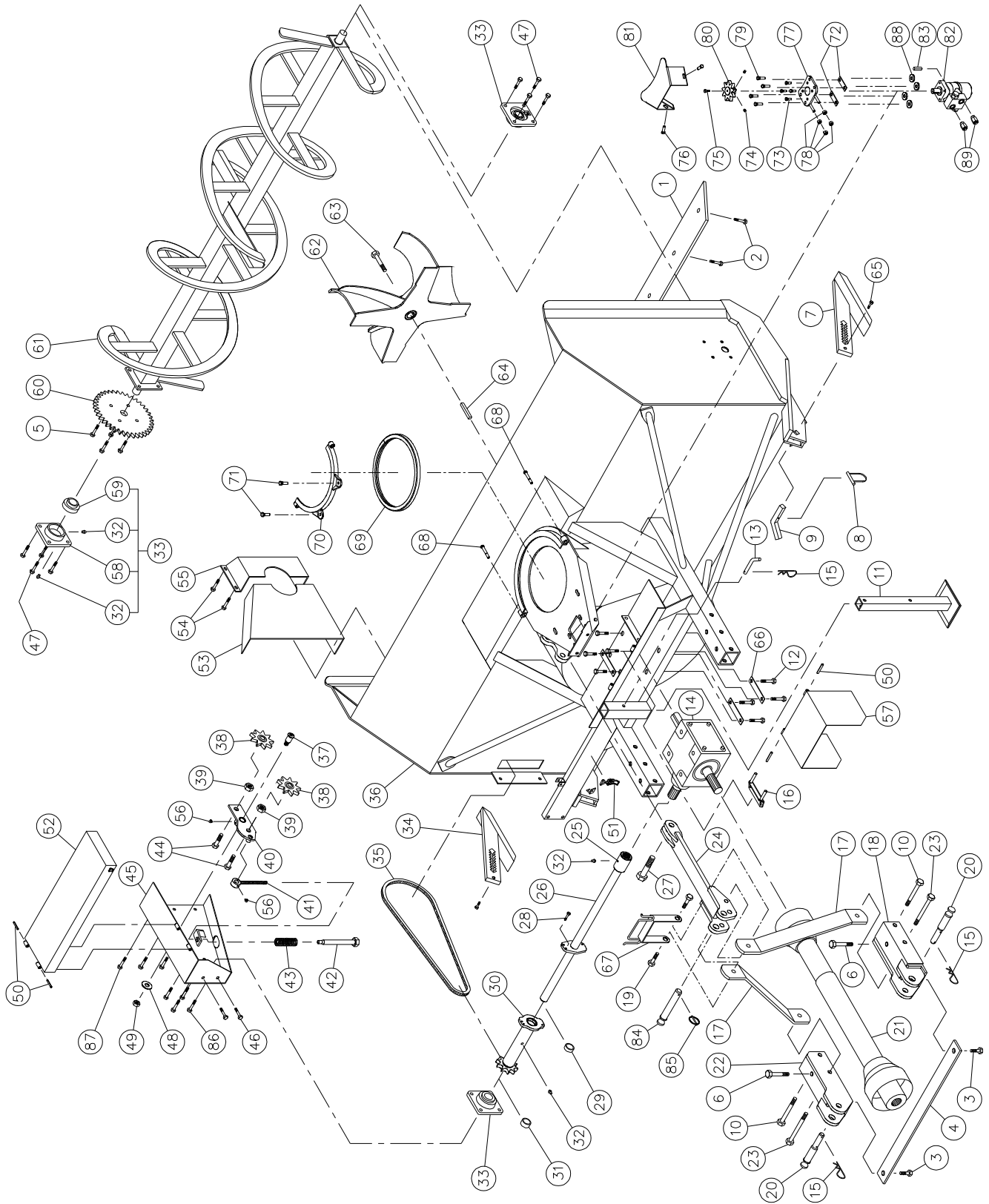

# SNOWBLOWERS P-740 P-800 P-860 P-860-92 (cont'd)

REF.	PART #	DESCRIPTION	QTY			
			P-740	P-800	P-860	P-860-92
1	140-00922	Reversible scraper blade 1/2" x 4" x 67 3/4" lg .....	1	-	-	-
1	140-00932	Reversible scraper blade 1/2" x 4" x 73 3/4" lg .....	-	1	-	-
1	140-00912	Reversible scraper blade 1/2" x 4" x 79 3/4" lg .....	-	-	1	-
1	140-09492	Reversible scraper blade 1/2" x 4" x 85 3/4" lg .....	-	-	-	1
2	319-38310	Plow bolt 7/16" x 1 1/2" lg + nut & lock washer .....	7	8	8	9
3	300-40310	Bolt 1/2" NC x 1 1/2" lg + nylon locknut .....	2	2	2	2
4	140-10862	Brace .....	1	1	-	-
4	140-10872	Brace .....	-	-	1	1
5	300-38310	Bolt 7/16" NC x 1 1/2" lg + two-way locknut .....	4	4	4	4
6	300-44490	Bolt 5/8" NC x 4 1/2" lg + nylon locknut .....	2	2	2	2
7	110-05491	Skid shoe (right side) .....	1	1	1	1
8	8112	Lock pin 1/4" .....	2	2	2	2
9	140-01861	Skid shoes lock .....	2	2	2	2
10	300-44520	Bolt 5/8" NC x 5" lg + nylon lock nut .....	2	2	2	2
11	8219	Storage support .....	1	1	1	1
12	300-40280	Bolt 1/2" NC x 1 1/4" lg + lock washer .....	8	8	8	8
13	8220	Storage support pin .....	1	1	1	1
14	8251	Gear box T27D .....	1	1	1	1
15	Std.	Hitch pin clip 5/32" .....	3	3	3	3
16	8199	Adjustment plate for gear box + 4 nuts 1/2" NC .....	1	1	1	1
17	140-10882	3-points side bar .....	2	2	-	-
17	140-23531	3-points side bar .....	-	-	2	2
18	110-15052	Right lower hitch .....	1	1	1	1
19	300-44355	Bolt 5/8" NC x 2 1/4" lg + nylon lock nut .....	2	2	2	2
20	8004	Pin category 1 & 2 .....	2	2	2	2
21	8114-EG	P.T.O. shaft T50 .....	1	1	-	-
21	8202	P.T.O. shaft T60 .....	opt.	opt.	1	1
21	9225-1	P.T.O. shaft T80 .....	-	-	opt.	opt.
22	110-15051	Left lower hitch .....	1	1	1	1
23	300-44550	Bolt 5/8" NC x 5 1/2" lg + nylon lock nut .....	2	2	2	2
24	110-15091	Upper hitch .....	1	1	1	1
25	6466	Splined adaptor 1 1/4"-19 (welded) .....	1	1	1	1
26	110-05632	Auger drive shaft 26 5/8" lg overall (includes no. 25) .....	1	-	-	-
26	110-05642	Auger drive shaft 29 5/8" lg overall (includes no. 25) .....	-	1	-	-
26	110-05652	Auger drive shaft 32 5/8" lg overall (includes no. 25) .....	-	-	1	-
26	110-13172	Auger drive shaft 35 5/8" lg overall (includes no. 25) .....	-	-	-	1
27	300-50400	Bolt 1" NC x 3" lg + nylon lock nut .....	1	1	1	1
28	300-32310	Bolt 1/4" NC x 1 1/2" lg grade 5+ nylon lock nut .....	1	1	1	1
29	160-26511	Bushing 1/4" i.d. x 1 1/2" o.d. x 3/8" lg .....	1	1	1	1
30	110-07272	Sprocket #80 + shearplate (includes no. 29, 31 and 32) .....	1	1	1	1
31	160-26501	Bushing 1 1/4" i.d. x 1 1/2" o.d. x 5/8" lg .....	2	2	2	2
32	Std.	Grease fitting 1/4"-28 straight .....	8	8	8	8
33	UCFD207-20	Bearing 1 1/4" + flange & 2 grease fitting (straight) .....	3	3	3	3
34	110-03151	Skid shoe (left side) .....	1	1	1	1
35	190-01441	Chain #80 x 77" lg (77 links) .....	1	1	1	1
35	26A80	Connecting link #80 .....	1	1	1	1
35	59-80	Offset link .....	1	1	1	1
36	120-03316	Frame P-740 .....	1	-	-	-
36	120-03355	Frame P-800 .....	-	1	-	-
36	120-03236	Frame P-860 .....	-	-	1	-
36	120-03416	Frame P-860-92 .....	-	-	-	1
37	150-00381	Idler clevis pin .....	1	1	1	1
38	9287	Idler sprocket #80 .....	2	2	2	2
39	336-48000	Nut 7/8" NC .....	2	2	2	2
40	110-01211	Idler .....	1	1	1	1
41	110-01232	Threaded rod for idler adjustment + nut 7/16" NC .....	1	1	1	1
42	110-01221	Threaded tube for idler adjustment .....	1	1	1	1

# SNOWBLOWERS P-740 P-800 P-860 P-860-92 (cont'd)

REF.	PART #	DESCRIPTION	QTY			
			P-740	P-800	P-860	P-860-92
43	9473	Compression spring .....	1	1	1	1
44	302-46400	Bolt 3/4" NC x 3" lg + nylon locknut .....	2	2	2	2
45	110-11733	Chainguard .....	1	1	1	1
46	300-38250	Bolt 7/16" NC x 1" lg + nylon lock nut .....	5	5	5	5
47	300-40325	Bolt 1/2" NC x 1 3/4" lg + nylon lock nut & flat washer 7/16" .....	8	8	8	8
48	376-44000	Flat washer 5/8" .....	1	1	1	1
49	346-45000	Nylon locknut 5/8" NC thin .....	1	1	1	1
50	Std.	Roll pin 5/16" x 2" lg .....	4	4	4	4
51	8374	Adjustable clamp fastener (welded) .....	1	1	1	1
52	110-20762	Auger drive shaft guard .....	1	-	-	-
52	110-20772	Auger drive shaft guard .....	-	1	-	-
52	110-20552	Auger drive shaft guard .....	-	-	1	-
52	110-20962	Auger drive shaft guard .....	-	-	-	1
53	130-02001	Inside guard (welded) .....	1	1	1	1
54	300-36250	Bolt 3/8" NC x 1" lg + nylon lock nut & flat washer .....	4	4	4	4
55	8018	Inside guard (bolted) .....	1	1	1	1
56	Std.	Grease fitting 1/4" - 28 90 deg. ....	2	2	2	2
57	110-12421	Hinged P.T.O. shroud .....	1	1	1	1
58	FD207	Flange for grease fitting .....	3	3	3	3
59	UC207-20	Bearing 1 1/4" .....	3	3	3	3
60	8185	Sprocket 80A30 T 1 1/4" ø .....	1	1	1	1
61	8023	Auger P-740 .....	1	-	-	-
61	8024	Auger P-800 .....	-	1	-	-
61	8025	Auger P-860 .....	-	-	1	-
61	110-13201	Auger P-860-92 .....	-	-	-	1
62	110-01872	Impeller 26" ø 4 blades .....	1	1	-	-
62	110-01882	Impeller 28" ø 4 blades .....	-	-	1	1
63	300-44310	Impeller cap screw 5/8" NC x 1 1/2" (ass. with lock-tite 242) + lock washer .....	1	1	1	1
64	8030	Square key 3/8" x 3/8" x 3 1/2" lg .....	1	1	1	1
65	300-32280	Boulon 1/4" NC x 1 1/4" lg + nylon locknut .....	2	2	2	2
66	140-10571	Back plate .....	3	3	3	3
67	110-15291	Hoses support .....	1	1	1	1
68	300-38400	Bolt 7/16" NC x 3" lg + nylon locknut .....	2	2	2	2
69	8149	U-shaped UHMW approx. 14" int. dia. ....	1	1	1	1
70	110-01341	Retaining bracket .....	1	1	1	1
71	300-40310	Bolt 1/2" NC x 1 1/2" lg + nylon locknut & flat washer .....	2	2	2	2
72	140-09571	Spacer 1/8" x 1" x 3 1/4" lg for «Orbit» motor .....	2	2	2	2
73	300-36250	Bolt 3/8" NC x 1" lg + locknut .....	4	4	4	4
74	323-36160	Hexagonal socket set screw 3/8" NC x 3/8" lg .....	2	2	2	2
75	300-32220	Bolt 1/4" NC x 3/4" lg + locknut .....	1	1	1	1
76	300-38280	Bolt 7/16" NC x 1 1/4" lg + nylon locknut & flat washer .....	2	2	2	2
77	110-20811	"Orbit" motor support .....	1	1	1	1
78	336-38000	Nut 7/16" NC .....	4	4	4	4
79	300-38310	Bolt 7/16" NC x 1 1/2" lg + nylon locknut .....	4	4	4	4
80	110-44331	Sprocket 9 tooth .....	1	1	1	1
81	130-08162	Guard .....	1	1	1	1
82	MLH-250	Hydraulic "Orbit" motor + cushion valve .....	opt.	opt.	opt.	opt.
82	MLH-315	Hydraulic "Orbit" motor + cushion valve .....	opt.	opt.	opt.	opt.
83	8369	Key for hydraulic "Orbit" motor .....	opt.	opt.	opt.	opt.
84	150-05961	Pin category 2 (top of 3 point) .....	1	1	1	1
85	Std.	Lynch pin .....	1	1	1	1
86	360-40310	Bolt 1/2" NC x 1 1/2" lg + nylon locknut (thin) & flat washer 7/16" .....	4	4	4	4
87	300-38250	Bolt 7/16" NC x 1" lg + nylon locknut & flat washer 3/8" .....	3	3	3	3
88	150-12741	Flat washer .....	4	4	4	4
89	RSP-1/16x100RB	Kit of 2 unidirectionals restrictors .....	opt.	opt.	opt.	opt.

# SNOWBLOWERS P-740TRC P-800TRC P-860TRC P-860TRC-92

170-03741R5

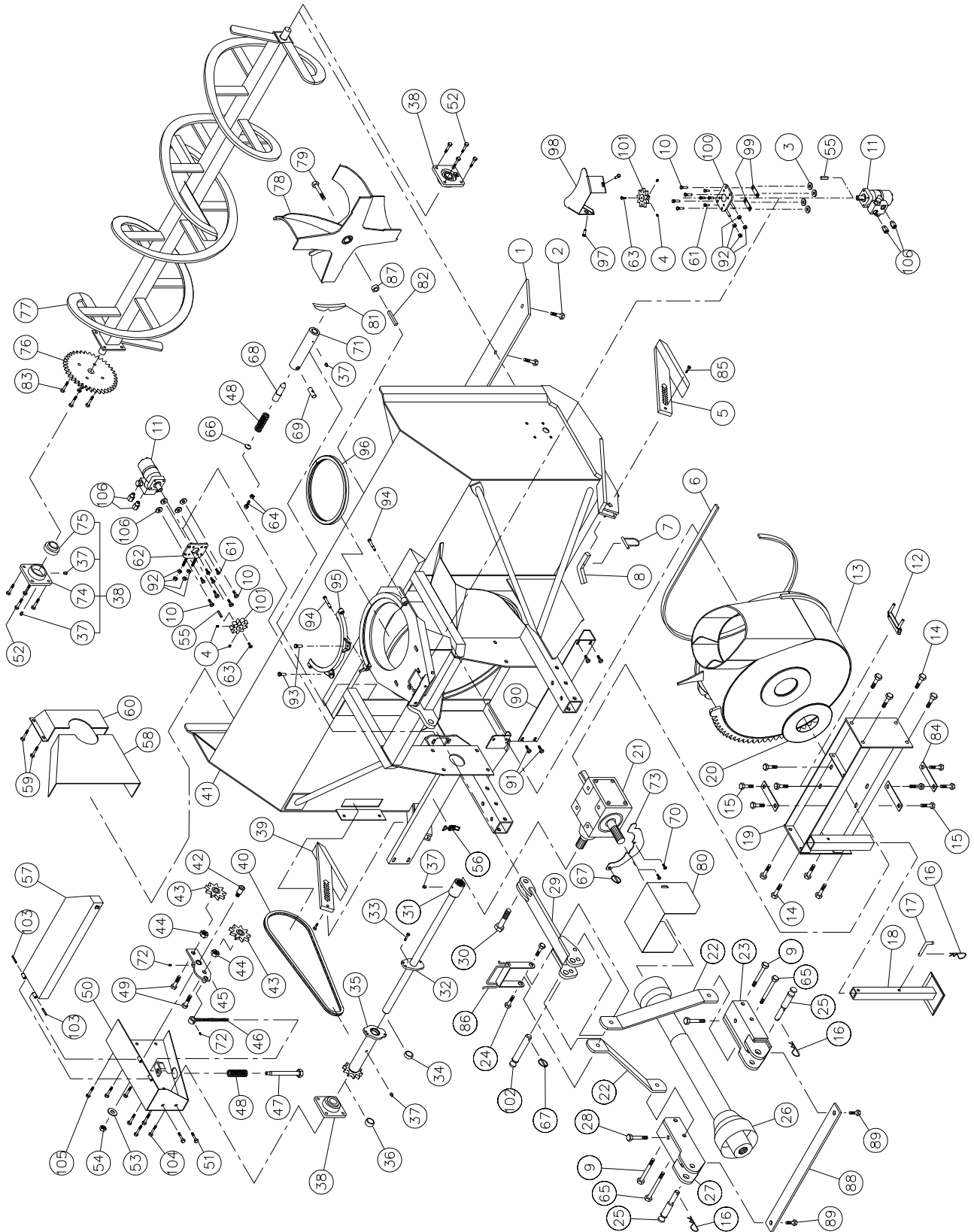

10



# SNOWBLOWERS P-740TRC P-800TRC P-860TRC P-860TRC-92 (cont'd)

REF.	PART #	DESCRIPTION	QTY			
			P-740TRC	P-800TRC	P-860TRC	P-860TRC-92
1	140-00922	Reversible scraper blade 1/2" x 4" x 67 3/4" lg .....	1	-	-	-
1	140-00932	Reversible scraper blade 1/2" x 4" x 73 3/4" lg .....	-	1	-	-
1	140-00912	Reversible scraper blade 1/2" x 4" x 79 3/4" lg .....	-	-	1	-
1	140-09492	Reversible scraper blade 1/2" x 4" x 85 3/4" lg .....	-	-	-	1
2	319-38310	Plow bolt 7/16" NC x 1 1/2" lg + nut & lock washer .....	7	8	8	9
3	150-12741	Flat washer 7/16" heavy-duty .....	8	8	8	8
4	323-36160	Hexagonal socket set screw 3/8" NC x 3/8" lg (2) .....	4	4	4	4
5	110-05491	Skid shoe (right side) .....	1	1	1	1
6	8195	U-shaped UHMW 3/8" x 7/8" x 84 5/8" lg .....	1	1	-	-
6	8196	U-shaped UHMW 3/8" x 7/8" x 91" lg .....	-	-	1	1
7	8112	Lock pin 1/4" .....	2	2	2	2
8	140-01861	Skid shoes lock .....	2	2	2	2
9	300-44520	Bolt 5/8" NC x 5" lg + nylon lock nut .....	2	2	2	2
10	300-38310	Bolt 7/16" NC x 1 1/2" lg + nylon locknut .....	8	8	8	8
11	MLH-250	Hydraulic "Orbit" motor with cushion valve .....	opt.	opt.	opt.	opt.
11	MLH-315	Hydraulic "Orbit" motor with cushion valve .....	opt.	opt.	opt.	opt.
12	8199	Adjustment plate for gear box + 4 nuts 1/2" NC .....	1	1	1	1
13	110-12442	Rotary drum 26" ø .....	1	1	-	-
13	110-12432	Rotary drum 28" ø .....	-	-	1	1
14	300-44310	Bolt 5/8" NC x 1 1/2" lg + nylon lock nut .....	8	8	8	8
15	300-40280	Bolt 1/2" NC x 1 1/4" lg + lockwasher .....	8	8	8	8
16	Std.	Hitch pin clip 5/32" .....	3	3	3	3
17	8220	Storage support pin .....	1	1	1	1
18	8219	Storage support .....	1	1	1	1
19	8230	Gear box support .....	1	1	-	-
19	8231	Gear box support .....	-	-	1	1
20	8232	UHMW flat washer 3/16" x 4 5/8" i.d. x 8 1/8" o.d. ....	1	1	1	1
21	8251	Gear box T-27D .....	1	1	1	1
22	140-10751	3-points side bar .....	2	2	-	-
22	140-10691	3-points side bar .....	-	-	2	2
23	110-15052	Right lower hitch .....	1	1	1	1
24	300-44355	Bolt 5/8" NC x 2 1/4" lg + nylon lock nut .....	2	2	2	2
25	8004	Pin category 1 & 2 .....	2	2	2	2
26	8114-EG	P.T.O. shaft T50 .....	1	1	-	-
26	8202	P.T.O. shaft T60 .....	opt.	opt.	1	1
26	9225-1	P.T.O. shaft T80 .....	-	-	opt.	opt.
27	110-15051	Left lower hitch .....	1	1	1	1
28	300-44490	Bolt 5/8" NC x 4 1/2" lg + nylon lock nut .....	2	2	2	2
29	110-15071	Upper hitch .....	1	1	1	1
30	300-50400	Bolt 1" NC x 3" lg + nylon lock nut .....	1	1	1	1
31	6466	Splined adaptor 1 1/4" - 19 (welded) .....	1	1	1	1
32	110-05632	Auger drive shaft 26 5/8" lg overall (includes no. 31) .....	1	-	-	-
32	110-05642	Auger drive shaft 29 5/8" lg overall (includes no. 31) .....	-	1	-	-
32	110-05652	Auger drive shaft 32 5/8" lg overall (includes no. 31) .....	-	-	1	-
32	110-13172	Auger drive shaft 35 5/8" lg overall (includes no. 31) .....	-	-	-	1
33	300-32310	Bolt 1/4" NC x 1 1/2" lg grade 5 + nylon lock nut .....	1	1	1	1

# SNOWBLOWERS P-740TRC P-800TRC P-860TRC P-860TRC-92 (cont'd)

REF.	PART #	DESCRIPTION	QTY			
			P-740TRC	P-800TRC	P-860TRC	P-860TRC-92
34	160-26511	Bushing 1/4" i.d. x 1 1/2" o.d. x 3/8" lg .....	1	1	1	1
35	110-07272	Sprocket #80 + shearplate (includes no. 34, 36 et 37) .....	1	1	1	1
36	160-26501	Bushing 1 1/4" i.d. x 1 1/2" o.d. x 5/8" lg .....	1	1	1	1
37	Std.	Grease fitting 1/4"-28 straight .....	9	9	9	9
38	UCFD207-20	Bearing 1 1/4" + flange & 2 grease fitting (straight) .....	3	3	3	3
39	110-03151	Skid shoe (left side) .....	1	1	1	1
40	190-01441	Chain #80 x 77" lg (77 links) .....	1	1	1	1
40	26A80	Connecting link #80 .....	1	1	1	1
40	59-80	Offset link #80 .....	1	1	1	1
41	120-03335	Frame P-740TRC .....	1	-	-	-
41	120-03375	Frame P-800TRC .....	-	1	-	-
41	120-03255	Frame P-860TRC .....	-	-	1	-
41	120-03395	Frame P-860-92TRC .....	-	-	-	1
42	150-00381	Idler clevis pin .....	1	1	1	1
43	9287	Idler sprocket #80 .....	2	2	2	2
44	336-48000	Nut 7/8" NC .....	2	2	2	2
45	110-01211	Idler .....	1	1	1	1
46	110-01232	Threaded rod for idler adjustment + nut 7/16" NC .....	1	1	1	1
47	110-01221	Threaded tube for idler adjustment .....	1	1	1	1
48	9473	Compression spring .....	2	2	2	2
49	302-46400	Bolt 3/4" NC x 3" lg + nylon locknut .....	2	2	2	2
50	110-11733	Chain guard .....	1	1	1	1
51	300-38250	Bolt 7/16" NC x 1" lg + nylon lock nut .....	2	2	2	2
52	300-40325	Bolt 1/2" NC x 1 3/4" lg + nylon lock nut & flat washer 7/16" .....	8	8	8	8
53	376-44000	Flat washer 5/8" .....	1	1	1	1
54	346-45000	Nylon locknut 5/8" NC thin .....	1	1	1	1
55	8369	Key for hydraulic motor .....	opt.	opt.	opt.	opt.
56	8374	Adjustable clamp fastener (welded) .....	1	1	1	1
57	110-20792	Auger drive shaft guard .....	1	-	-	-
57	110-20622	Auger drive shaft guard .....	-	1	-	-
57	110-20532	Auger drive shaft guard .....	-	-	1	-
57	110-20802	Auger drive shaft guard .....	-	-	-	1
58	130-02001	Inside guard (welded) .....	1	1	1	1
59	300-36250	Bolt 3/8" NC x 1" lg + nylon locknut & flat washer .....	4	4	4	4
60	8018	Inside guard (bolted) .....	1	1	1	1
61	300-36250	Bolt 3/8" NC x 1" lg + lock washer .....	8	8	8	8
62	110-18441	Orbit motor support .....	1	1	1	1
63	300-32220	Bolt 1/4" NC x 3/4" lg + lock washer .....	2	2	2	2
64	300-38341	Bolt 7/16" NC x 2" lg (full length thread) + lock nut .....	1	1	1	1
65	300-44550	Bolt 5/8" NC x 5 1/2" lg + nylon locknut .....	2	2	2	2
66	130-08471	Washer .....	1	1	1	1
67	Std.	Lynch pin .....	2	2	2	2
68	150-01542	Latch pin - drum lock .....	1	1	1	1
69	150-02561	Pin .....	1	1	1	1
70	309-32016	Bolt M8 x 1.25 x 16 mm lg + lock washer .....	2	2	2	2
71	160-03952	Body - drum lock (welded on frame) .....	1	1	1	1

# SNOWBLOWERS P-740TRC P-800TRC P-860TRC (cont'd)

REF.	PART #	DESCRIPTION	QTY			
			P-740TRC	P-800TRC	P-860TRC	P-860TRC-92
72	Std.	Grease fitting 1/4" - 28 90 deg. ....	2	2	2	2
73	130-14151	Guard mounting plate .....	1	1	1	1
74	FD207	Flange for 2 grease fitting .....	3	3	3	3
75	UC207-20	Bearing 1 1/4" .....	3	3	3	3
76	8185	Sprocket 80A30 T 1 1/4" ø .....	1	1	1	1
77	8023	Auger P-740 .....	1	-	-	-
77	8024	Auger P-800 .....	-	1	-	-
77	8025	Auger P-860 .....	-	-	1	-
77	110-13201	Auger P-860-92 .....	-	-	-	1
78	110-01872	Impeller 26" ø 4 blades .....	1	1	-	-
78	110-01882	Impeller 28" ø 4 blades .....	-	-	1	1
79	300-44340	Impeller cap screw 5/8" NC x 2" lg (ass. with lock-tite 242) + lock washer .....	1	1	1	1
80	130-14142	Hinged P.T.O. shroud .....	1	1	1	1
81	130-29511	Stop block for drum lock (welded on drum) .....	1	1	-	-
81	130-29501	Stop block for drum lock (welded on drum) .....	-	-	1	1
82	8030	Square key 3/8" x 3/8" x 3 1/2" lg .....	1	1	1	1
83	300-38310	Bolt 7/16" NC x 1 1/2" lg + two-way locknut .....	4	4	4	4
84	140-10571	Back plate .....	3	3	3	3
85	300-32280	Bolt 1/4" NC x 1 1/4" lg + nylon locknut .....	2	2	2	2
86	110-15291	Hoses support .....	1	1	1	1
87	8298	Spacer 3/4" i.d. x 1 1/4" o.d. x 9/16" lg .....	1	1	1	1
88	140-10851	Brace 3/8" x 1 1/2" x 32 3/16" lg .....	1	1	-	-
88	140-10651	Brace 3/8" x 1 1/2" x 34 3/16" lg .....	-	-	1	1
89	300-40310	Bolt 1/2" NC x 1 1/2" lg + nylon locknut .....	2	2	2	2
90	130-29321	Guard for ring gear segment .....	1	1	-	-
90	130-29151	Guard for ring gear segment .....	-	-	1	1
91	300-40280	Bolt 1/2" NC x 1 1/4" lg + nylon locknut & flat washer .....	4	4	4	4
92	336-38000	Nut 7/16" NC .....	8	8	8	8
93	300-40310	Bolt 1/2" NC x 1 1/2" lg + nylon locknut & flat washer .....	2	2	2	2
94	300-38400	Bolt 7/16" NC x 3" lg + nylon locknut .....	2	2	2	2
95	110-01341	Retaining bracket .....	1	1	1	1
96	8149	U-shaped UHMW approx. 14" ø int. ....	1	1	1	1
97	300-38280	Bolt 7/16" NC x 1 1/4" lg + nylon locknut & flat washer .....	2	2	2	2
98	130-08162	Guard .....	1	1	1	1
99	140-09571	Spacer 1/8" x 1" x 3 1/4" lg for "Orbit" motor .....	2	2	2	2
100	110-20811	"Orbit" motor support .....	1	1	1	1
101	110-44331	Sprocket 9 tooth .....	2	2	2	2
102	150-05961	Pin category 2 (top of 3 point) .....	1	1	1	1
103	Std.	Roll pin 5/16" x 2" lg .....	2	2	2	2
104	300-40310	Bolt 1/2" NC x 1 1/2" lg + nylon locknut (thin) & flat washer 7/16" .....	4	4	4	4
105	300-38250	Bolt 7/16" NC x 1" lg + nylon locknut & flat washer 3/8" .....	3	3	3	3
106	RSP-1/16x100RB	Kit of 2 unidirectional restrictors .....	opt.	opt.	opt.	opt.

# SNOWBLOWER P-862

170-03755R1

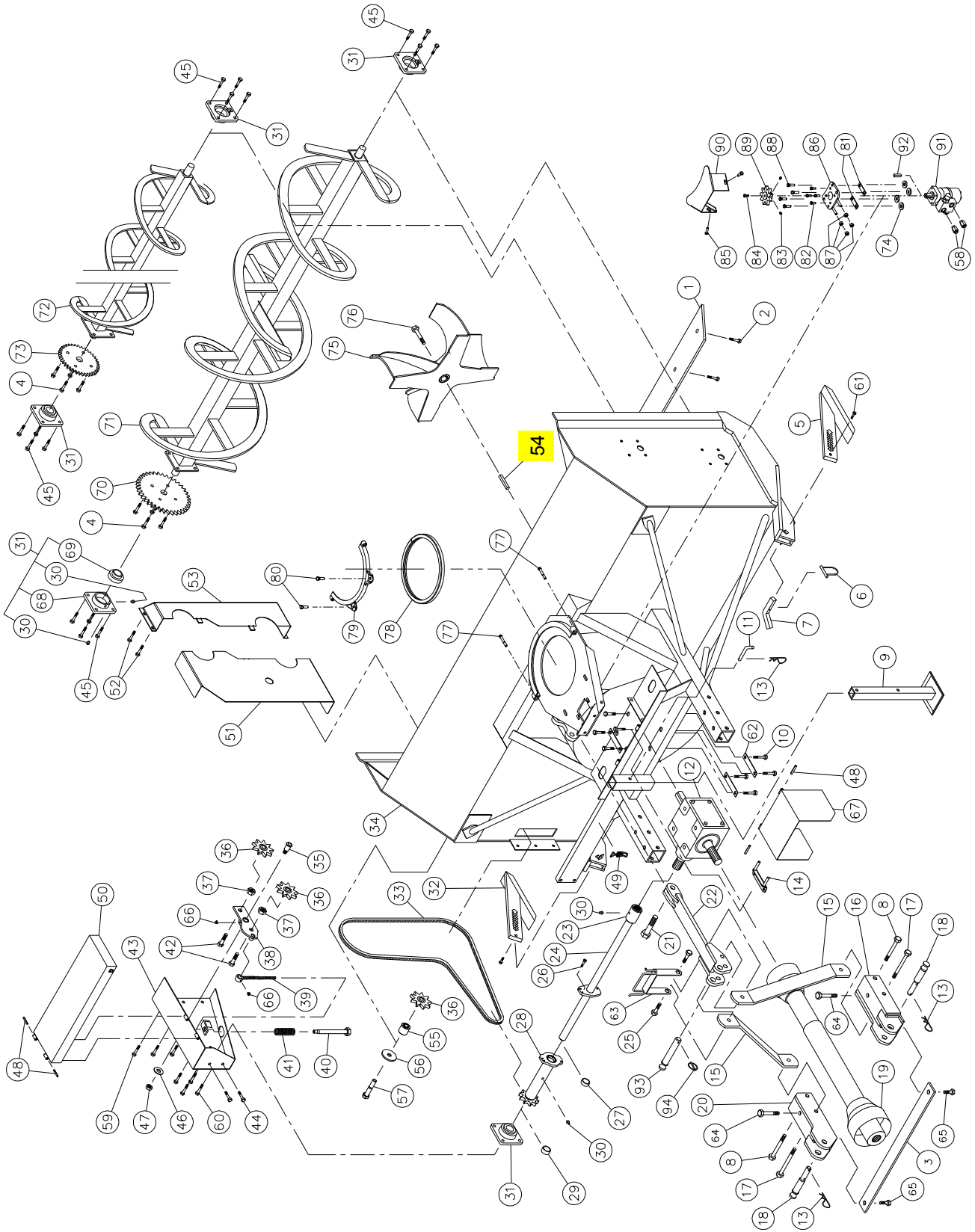

10

## SNOWBLOWER P-862 (cont'd)

REF.	PART #	DESCRIPTION	QTY
1	140-00912	Reversible scraper blade 1/2" x 4" x 79 3/4" lg .....	1
2	319-38310	Plow bolt 7/16" NC x 1 1/2" lg + nut & lock washer .....	8
3	140-10872	Brace 3/8" x 1 1/2" x 32 1/16" lg .....	1
4	300-38310	Bolt 7/16" NC x 1 1/2" lg + two-way locknut .....	8
5	110-05491	Skid shoe (right side) .....	1
6	8112	Lock pin 1/4" .....	2
7	140-01861	Skid shoes lock .....	2
8	300-44520	Bolt 5/8" NC x 5" lg + nylon locknut .....	2
9	8219	Storage support .....	1
10	300-40280	Bolt 1/2" NC x 1 1/4" lg + lock washer .....	8
11	8220	Storage support pin .....	1
12	8251	Gear box .....	1
13	Std.	Hitch pin clip 5/32" .....	3
14	110-05321	Adjustment plate for gear box + 4 nuts 1/2" NC .....	1
15	140-23531	3-points side bar .....	2
16	110-15052	Right lower hitch .....	1
17	300-44550	Bolt 5/8" NC x 5 1/2" lg + nylon locknut .....	2
18	8004	Pin category 1 & 2 .....	2
19	8202	P.T.O. shaft T60 .....	1
19	9225-1	P.T.O. shaft T80 .....	opt.
20	110-15051	Left lower hitch .....	1
21	300-50400	Bolt 1" NC x 3" lg + nylon locknut .....	1
22	110-15091	Upper hitch .....	1
23	6466	Splined adaptor 1 1/4" - 19 splines (welded) .....	1
24	110-05652	Auger drive shaft 32 5/8" lg overall (includes no. 23) .....	1
25	300-44355	Bolt 5/8" NC x 2 1/4" lg + nylon locknut .....	2
26	300-32310	Bolt 1/4" NC x 1 1/2" lg grade 5 + nylon locknut .....	1
27	160-26511	Bushing 1/4" i.d. x 1 1/2" o.d. x 3/8" lg .....	1
28	110-07272	Sprocket #80 + shearplate (includes no. 27, 29 and 30) .....	1
29	160-26501	Bushing 1 1/4" i.d. x 1 1/2" o.d. x 5/8" lg .....	1
30	Std.	Grease fitting 1/4"-28 straight .....	12
31	UCFD207-20	Bearing 1 1/4" + flange & 2 grease fitting (straight) .....	5
32	110-03151	Skid shoe (left side) .....	1
33	190-11821	Chain # 80 x 110" lg (110 links) .....	1
33	26A80	Connecting link #80 .....	1
33	59-80	Offset link #80 .....	1
34	120-03277	Frame P-862 .....	1
35	150-00381	Idler clevis pin .....	1
36	9287	Idler sprocket #80 .....	3
37	336-48000	Nut 7/8" NC .....	2
38	110-01211	Idler .....	1
39	110-01232	Threaded rod for idler adjustment + nut 7/16" NC .....	1
40	110-01221	Threaded tube for idler adjustment .....	1
41	9473	Compression spring .....	1
42	300-46370	Bolt 3/4" NC x 2 1/2" lg + nylon locknut .....	2
43	110-11733	Chain guard .....	1
44	300-38250	Bolt 7/16" NC x 1" lg + nylon locknut .....	2
45	300-40325	Bolt 1/2" NC x 1 3/4" lg + nylon locknut & flat washer 7/16" .....	16
46	376-44000	Flat washer 5/8" .....	1
47	346-45000	Nylon locknut 5/8" NC thin .....	1
48	Std.	Roll pin 5/16" x 2" lg .....	4
49	8374	Adjustable clamp fastener (welded) .....	1
50	110-20552	Auger drive shaft guard .....	1

## SNOWBLOWER P-862 (cont'd)

REF.	PART #	DESCRIPTION	QTY
51	130-77211	Inside guard (welded) .....	1
52	300-36250	Bolt 3/8" NC x 1" lg + nylon locknut & flat washer .....	4
53	110-42541	Inside guard (bolted) .....	1
54	8030	Square key 3/8" x 3/8" x 3 1/2" lg .....	1
55	150-13911	Diverter spacer .....	1
56	130-77191	Diverter reinforcing washer .....	1
57	300-46460	Bolt 3/4" NC x 4" lg + nylon locknut .....	1
58	RSP-1/16x10 ORB	Kit of 2 unidirectional restrictors .....	opt.
59	300-38250	Bolt 7/16 NC x 1" lg + nylon locknut & flat washer 3/8" .....	3
60	300-40310	Bolt 1/2" NC x 1 1/2" lg + nylon locknut & flat washer 7/16" .....	4
61	300-32280	Bolt 1/4" NC x 1 1/4" lg + nylon locknut .....	2
62	140-10571	Back plate .....	3
63	110-15291	Hoses support .....	1
64	300-44490	Bolt 5/8" NC x 4 1/2" lg + nylon locknut .....	2
65	300-40310	Bolt 1/2" NC x 1 1/2" lg + nylon locknut .....	2
66	Std.	Grease fitting 1/4" - 28 90 deg. ....	2
67	110-12421	Hinged P.T.O. shroud .....	1
68	FD207	Flange for 2 grease fitting .....	5
69	UC207-20	Bearing 1 1/4" .....	5
70	8185	Sprocket 80A30 T 1 1/4" ø .....	1
71	8025	Lower auger P-862 .....	1
72	110-42522	Upper auger P-862 .....	1
73	190-11811	Sprocket 80A24 T 1 1/4" ø .....	1
74	150-12741	Flat washer 7/16" heavy-duty .....	4
75	110-01882	Impeller 28" ø 4 blades .....	1
76	300-44310	Impeller cap screw 5/8" NC x 1 1/2" lg (ass. with lock-tite 242) + lock washer .....	1
77	300-38400	Bolt 7/16" NC x 3" lg + nylon locknut .....	2
78	8149	U-shaped UHMW approx. 14" int. dia. ....	1
79	110-01341	Retaining bracket .....	1
80	300-40310	Bolt 1/2" NC x 1 1/2" lg + nylon locknut & flat washer .....	2
81	140-09571	Spacer 1/8" x 1" x 3 1/4" lg for «Orbit» motor .....	2
82	300-36250	Bolt 3/8" NC x 1" lg + locknut .....	4
83	323-36160	Hexagonal socket set screw 3/8" NC x 3/8" lg .....	2
84	300-32220	Bolt 1/4" NC x 3/4" lg + locknut .....	1
85	300-38280	Bolt 7/16" NC x 1 1/4" lg + nylon locknut & flat washer .....	2
86	110-20811	"Orbit" motor support .....	1
87	336-38000	Nut 7/16" NC .....	4
88	300-38310	Bolt 7/16" NC x 1 1/2" lg + nylon locknut .....	4
89	110-44331	Sprocket 9 tooth .....	1
90	130-08162	Guard .....	1
91	MLH-250	Hydraulic "Orbit" motor + cushion valve .....	opt.
91	MLH-315	Hydraulic "Orbit" motor + cushion valve .....	opt.
92	8369	Key for hydraulic "Orbit" motor .....	opt.
93	150-05961	Pin category 2 (top of 3 point) .....	1
94	Std.	Lynch pin 1/4" x 1 3/4" .....	1



# SNOWBLOWER P-862TRC

170-03763R1

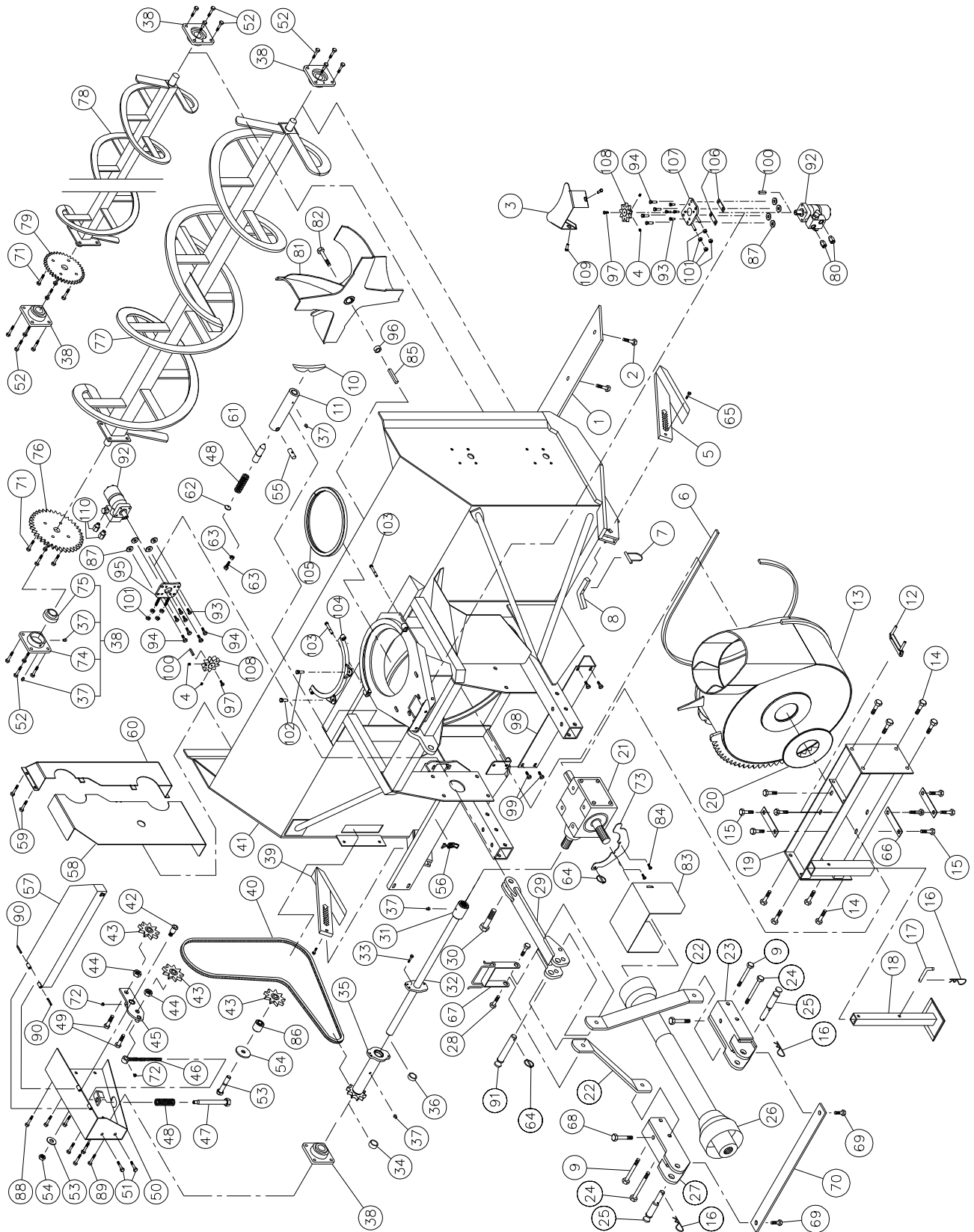

## SNOWBLOWER P-862TRC (cont'd)

REF.	PART #	DESCRIPTION	QTY
1	140-00912	Reversible scraper blade 1/2" x 4" x 79 3/4" lg .....	1
2	319-38310	Plow bolt 7/16" NC x 1 1/2" lg + nut & lockwasher .....	8
3	130-08162	Guard .....	1
4	323-36160	Hexagonal socket set screw 3/8" NC x 3/8" lg .....	4
5	110-05491	Skid shoe (right side) .....	1
6	8196	U-shaped UHMW 3/8" x 7/8" x 91" lg .....	1
7	8112	Lock pin 1/4" .....	2
8	140-01861	Skid shoes lock .....	2
9	300-44520	Bolt 5/8" NC x 5" lg + nylon locknut .....	2
10	130-29501	Stop block for drum lock (welded on drum) .....	1
11	160-03952	Body - drum lock (welded on frame) .....	1
12	110-05321	Adjustment plate for gear box + 4 nuts 1/2" NC .....	1
13	110-12432	Rotary drum 28" ø .....	1
14	300-44310	Bolt 5/8" NC x 1 1/2" lg + nylon locknut .....	8
15	300-40280	Bolt 1/2" NC x 1 1/4" lg + lock washer .....	8
16	Std.	Hitch pin clip 5/32" .....	3
17	8220	Storage support pin .....	1
18	8219	Storage support .....	1
19	110-02121	Gear box support .....	1
20	8232	UHMW flat washer 3/16" x 4 5/8" i.d. x 8 1/8" o.d. ....	1
21	8251	Gear box .....	1
22	140-10691	3-points side bar .....	2
23	110-15052	Right lower hitch .....	1
24	300-44550	Bolt 5/8" NC x 5 1/2" lg + nylon locknut .....	2
25	8004	Pin category 1 & 2 .....	2
26	8202	P.T.O. shaft T60 .....	1
26	9225-1	P.T.O. shaft T80 .....	opt.
27	110-15051	Left lower hitch .....	1
28	300-44355	Bolt 5/8" NC x 2 1/4" lg + nylon locknut .....	2
29	110-15071	Upper hitch .....	1
30	300-50400	Bolt 1" NC x 3" lg + nylon locknut .....	1
31	6466	Splined adaptor 1 1/4"-19 (welded) .....	1
32	110-05652	Auger drive shaft 32 5/8" lg overall (includes no. 31) .....	1
33	300-32310	Bolt 1/4" NC x 1 1/2" lg grade 5 + nylon locknut .....	1
34	160-26501	Bushing 1/4" i.d. x 1 1/2" o.d. x 5/8" lg .....	1
35	110-07272	Sprocket #80 + shearplate (includes no. 34, 36 and 37) .....	1
36	160-26511	Bushing 1 1/4" i.d. x 1 1/2" o.d. x 3/8" lg .....	1
37	Std.	Grease fitting 1/4"-28 straight .....	14
38	UCFD207-20	Bearing 1 1/4" + flange & 2 grease fitting (straight) .....	5
39	110-03151	Skid shoe (left side) .....	1
40	190-11821	Chain #80 x 110" lg (110 links) .....	1
40	26A80	Connecting link #80 .....	1
40	59-80	Offset link #80 .....	1
41	120-03297	Frame P-862TRC .....	1
42	150-00381	Idler clevis pin .....	1
43	9287	Idler sprocket #80 .....	3
44	336-48000	Nut 7/8" NC .....	2
45	110-01211	Idler .....	1
46	110-01232	Threaded rod for idler adjustment + nut 7/16" NC .....	1
47	110-01221	Threaded tube for idler adjustment .....	1
48	9473	Compression spring .....	2
49	300-46370	Bolt 3/4" NC x 2 1/2" lg + nylon locknut .....	2
50	110-11733	Chain guard .....	1
51	300-38250	Bolt 7/16" NC x 1" lg + nylon locknut .....	2
52	300-40325	Bolt 1/2" NC x 1 3/4" lg + nylon locknut & flat washer 7/16" .....	16
53	300-46460	Boulon 3/4" NC x 4" lg + nylon locknut .....	1
54	130-77191	Diverter reinforcing washer .....	1
55	150-02561	Pin .....	1
56	8374	Adjustable clamp fastener (welded) .....	1



## SNOWBLOWER P-862TRC (cont'd)

REF.	PART #	DESCRIPTION	QTY
57	110-20532	Auger drive shaft guard .....	1
58	130-77211	Inside guard (welded) .....	1
59	300-36250	Bolt 3/8" NC x 1" lg + nylon locknut & flat washer .....	4
60	110-42541	Inside guard (bolted) .....	1
61	150-01542	Latch pin - drum lock .....	1
62	130-08471	Washer .....	1
63	300-38341	Bolt 7/16" NC x 2" lg (full length thread) + locknut .....	1
64	Std.	Linch pin 1/4" x 1 3/4" lg .....	2
65	300-32280	Bolt 1/4" NC x 1 1/4" lg + nylon locknut .....	2
66	140-10571	Back plate .....	3
67	110-15291	Hoses support .....	1
68	300-44490	Bolt 5/8" NC x 4 1/2" lg + nylon locknut .....	2
69	300-40310	Bolt 1/2" NC x 1 1/2" lg + nylon locknut .....	2
70	140-10651	Brace 3/8" x 1 1/2" x 34 3/16" lg .....	1
71	300-38210	Bolt 7/16" NC x 1 1/2" lg + two-way locknut .....	8
72	Std.	Gease fitting 1/4" - 28 90 deg. ....	2
73	130-14151	Guard mounting plate .....	1
74	FD207	Flange for 2 grease fitting .....	5
75	UC207-20	Bearing 1 1/4" .....	5
76	8185	Sprocket 80A30 T 1 1/4" ø .....	1
77	8025	Lower auger P-862TRC .....	1
78	110-42522	Upper auger P-862TRC .....	1
79	190-11811	Sprocket 80A24 T 1 1/4" ø .....	1
80	RSP-1/16x10 ORB	Kit of 2 unidirectional restrictors .....	opt.
81	110-01882	Impeller 28" ø 4 blades .....	1
82	300-44340	Impeller cap screw 5/8" NC x 2" lg (ass. with lock-tite 242) + lock washer .....	1
83	130-14142	P.T.O. shroud .....	1
84	309-32016	Boulon Bolt M8 x 1.25 x 16 mm lg + lock washer .....	2
85	8030	Square key 3/8" x 3/8" x 3 1/2" lg .....	1
86	150-13911	Diverter spacer .....	1
87	150-12741	Flat washer 7/16" heavy-duty .....	8
88	300-38250	Bolt 7/16" NC x 1" lg + nylon locknut & flat washer 3/8" .....	3
89	300-40310	Bolt 1/2" NC x 1 1/2" lg + nylon locknut (thin) & flat washer 7/16" .....	4
90	Std.	Roll pin 5/16" x 2" .....	2
91	150-05961	Pin category 2 (top of 3 point) .....	1
92	MLH-250	Hydraulic orbit motor with cushion valve .....	opt.
92	MLH-315	Hydraulic orbit motor with cushion valve .....	opt.
93	300-36250	Bolt 3/8" NC x 1" lg + lock washer .....	8
94	300-38310	Bolt 7/16" NC x 1 1/2" lg + nylon locknut .....	8
95	130-08152	Orbit motor support .....	1
96	8298	Spacer 3/4" i.d. x 1 1/4" o.d. x 9/16" lg .....	1
97	300-32220	Bolt 1/4" NC x 3/4" lg + lock washer .....	2
98	130-29151	Guard for ring gear segment .....	1
99	300-40280	Bolt 1/2" NC x 1 1/4" lg + nylon locknut & flat washer .....	4
100	8369	Key for "Orbit" motor .....	opt.
101	336-38000	Nut 7/16" NC .....	8
102	300-40310	Bolt 1/2" NC x 1 1/2" lg + nylon locknut & flat washer .....	2
103	300-38400	Bolt 7/16" NC x 3" lg + nylon locknut .....	2
104	110-01341	Retaining bracket .....	1
105	8149	U-shaped UHMW approx. 14" ø int. ....	1
106	140-09571	Spacer 1/8" x 1" x 3 1/4" lg for "Orbit" motor .....	2
107	110-20811	"Orbit" motor support .....	1
108	110-44331	Sprocket 9 tooth .....	2
109	300-38280	Bolt 7/16" NC x 1 1/4" lg + nylon locknut & flat washer .....	2

# CHUTE CST-7486

170-03271R1

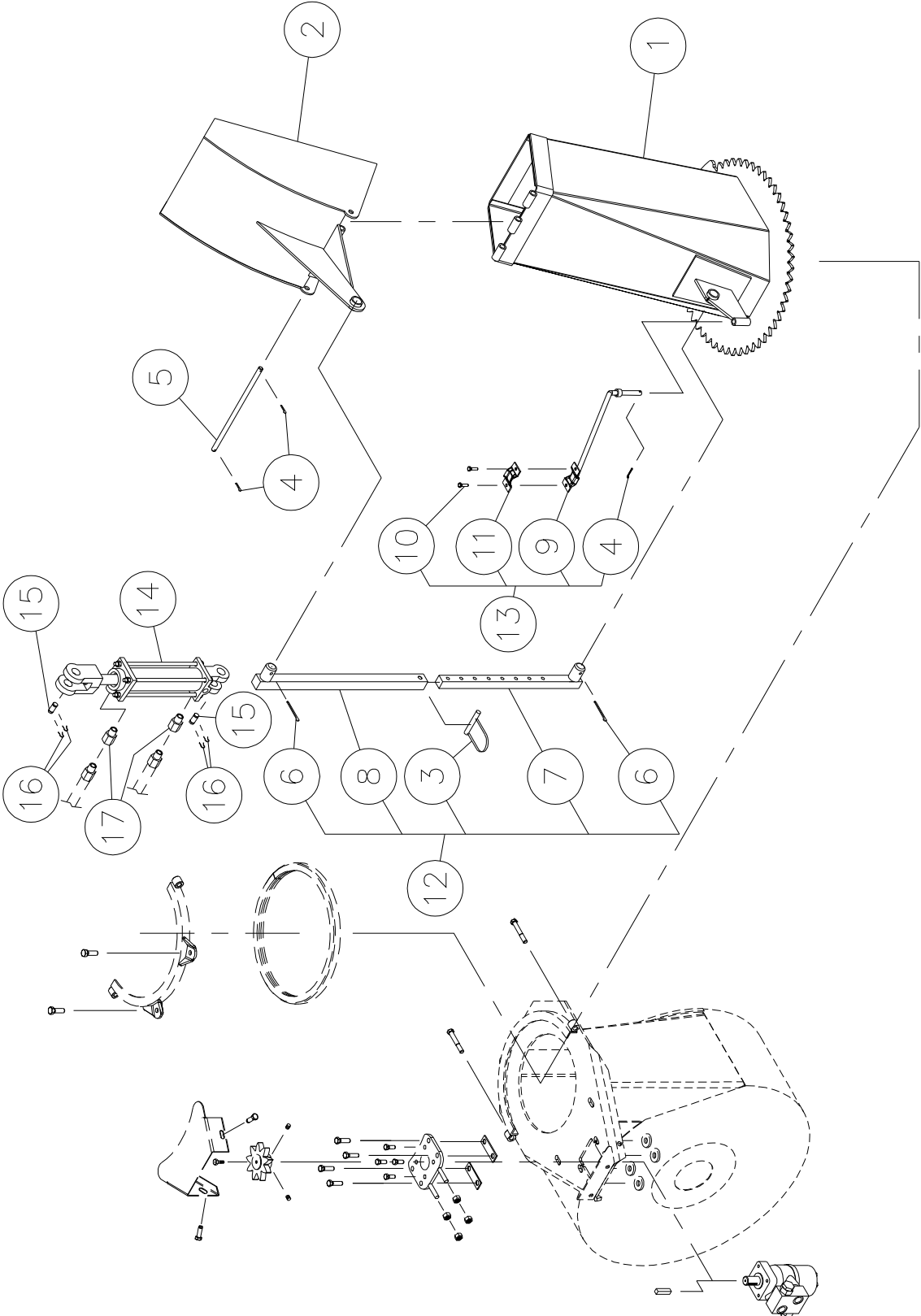

# CHUTE CST-7486

REF.	PART #	DESCRIPTION	QTY
1	110-04401	Chute base .....	1
2	8370	Chute deflector .....	1
3	8112	Lock pin 1/4" (1) .....	opt.
4	Std.	Cotter pin 1/8" x 1" lg .....	3
5	8210	Chute deflector pin .....	1
6	Std.	Cotter pin 5/32" x 2" lg (2) .....	opt.
7	8145	Chute adjusting rod (1) .....	opt.
8	8146	Chute adjusting tube (1) .....	opt.
9	110-01112	Mounting support plate .....	1
10	300-32250	Bolt 1/4" NC x 1" lg. + nylon locknut .....	2
11	140-13071	Hoses mounting plate .....	1
12	T-74104	Manual telescopic tube .....	opt.
13	TSB-74104	Hose support for deflector cylinder .....	opt.
14	25TR08	Cylinder .....	opt.
15	6004	Clevis pin 1" x 3 1/8" lg (2) .....	opt.
16	Std.	Hairpin cotter 7/8" (4) .....	opt.
17	RSP-1/16x06 NPT	Kit of 2 unidirectional restrictors 3/8" NPT .....	opt.
17	RSP-1/16x08 NPT	Kit of 2 unidirectional restrictors 1/2" NPT .....	opt.

# SEMI-INDUSTRIAL CHUTE PSIG-7486

170-03395

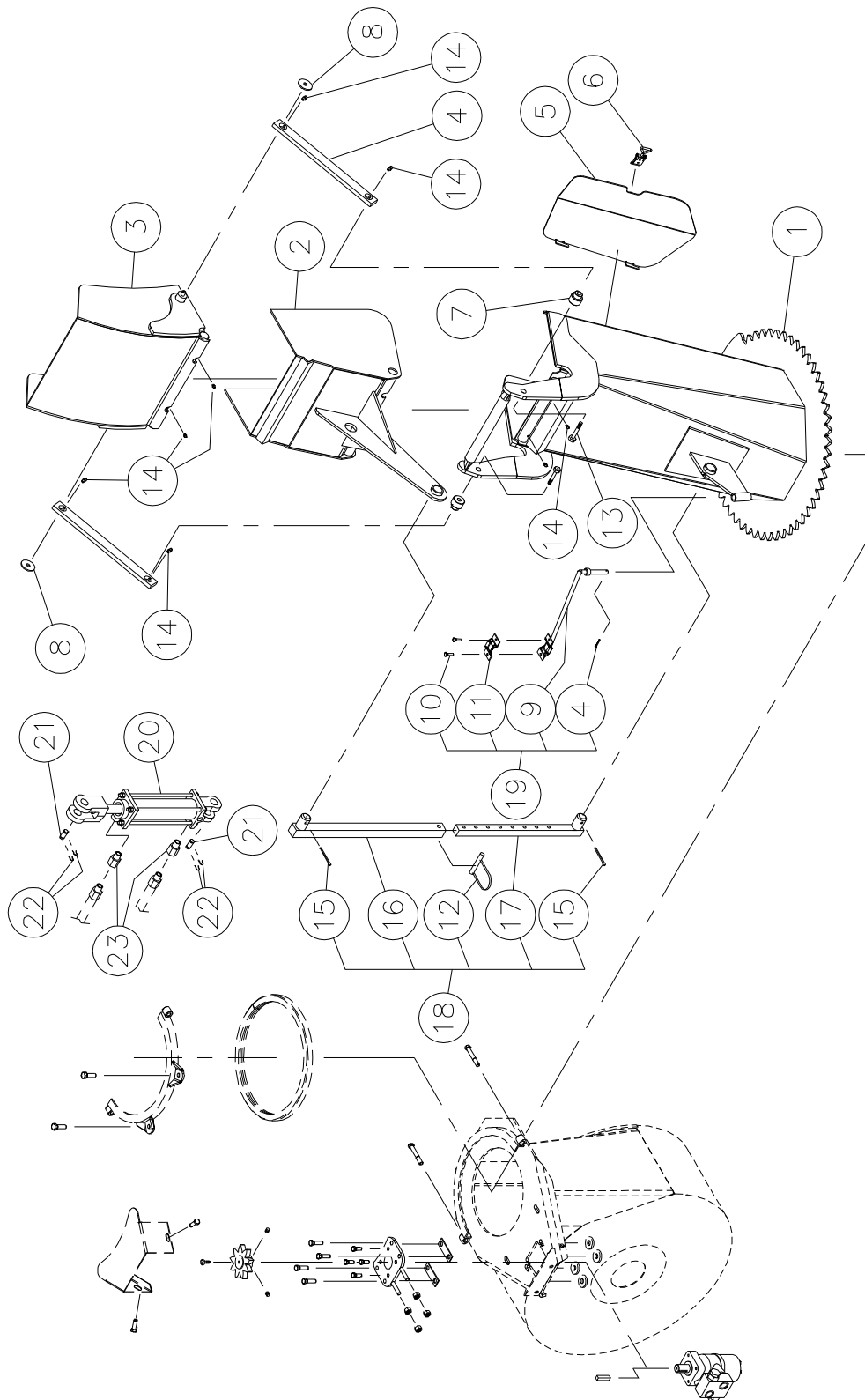

10

## **SEMI-INDUSTRIAL CHUTE PSIG -7486**

REF.	PART #	DESCRIPTION	QTY
1	110-45361	Chute base .....	1
2	110-22521	Lower chute deflector .....	1
3	110-22511	Upper chute deflector .....	1
4	140-14041	Connecting rod .....	2
5	110-45611	Access panel .....	1
6	8376	Adjustable clamp fastener (welded) .....	1
7	150-05311	Spacer for connecting rod .....	2
8	378-36500	Washer .....	2
9	110-01112	Hoses support .....	1
10	300-32250	Bolt 1/4" NC x 1" lg + nylon locknut .....	2
11	140-13071	Hose hold down .....	1
12	8112	Lock pin 1/4" (1) .....	opt.
13	300-40380	Bolt 1/2" NC x 2 3/4" lg + nylon lock nut & washer .....	2
14	Std.	Grease firtting 1/4"-28 straight .....	8
15	Std.	Cotter pin 5/32" x 2" lg (2) .....	opt.
16	8146	Chute adjusting tube (1) .....	opt.
17	8145	Chute adjusting rod (1) .....	opt.
18	T-74104	Manual telescopic tube .....	opt.
19	TSB-74104	Hose support for deflector cylinder .....	opt.
20	25TR08	Cylinder .....	opt.
21	6004	Clevis pin 1" x 3 1/8" lg (2) .....	opt.
22	Std.	Hairpin cotter 7/8" (4) .....	opt.
23	RSP-1/16x06 NPT	Kit of 2 unidirectional restrictors 3/8" NPT .....	opt.
23	RSP-1/16x08 NPT	Kit of 2 unidirectional restrictors 1/2" NPT .....	opt.

# INDUSTRIAL CHUTE PCG-7486

170-03415

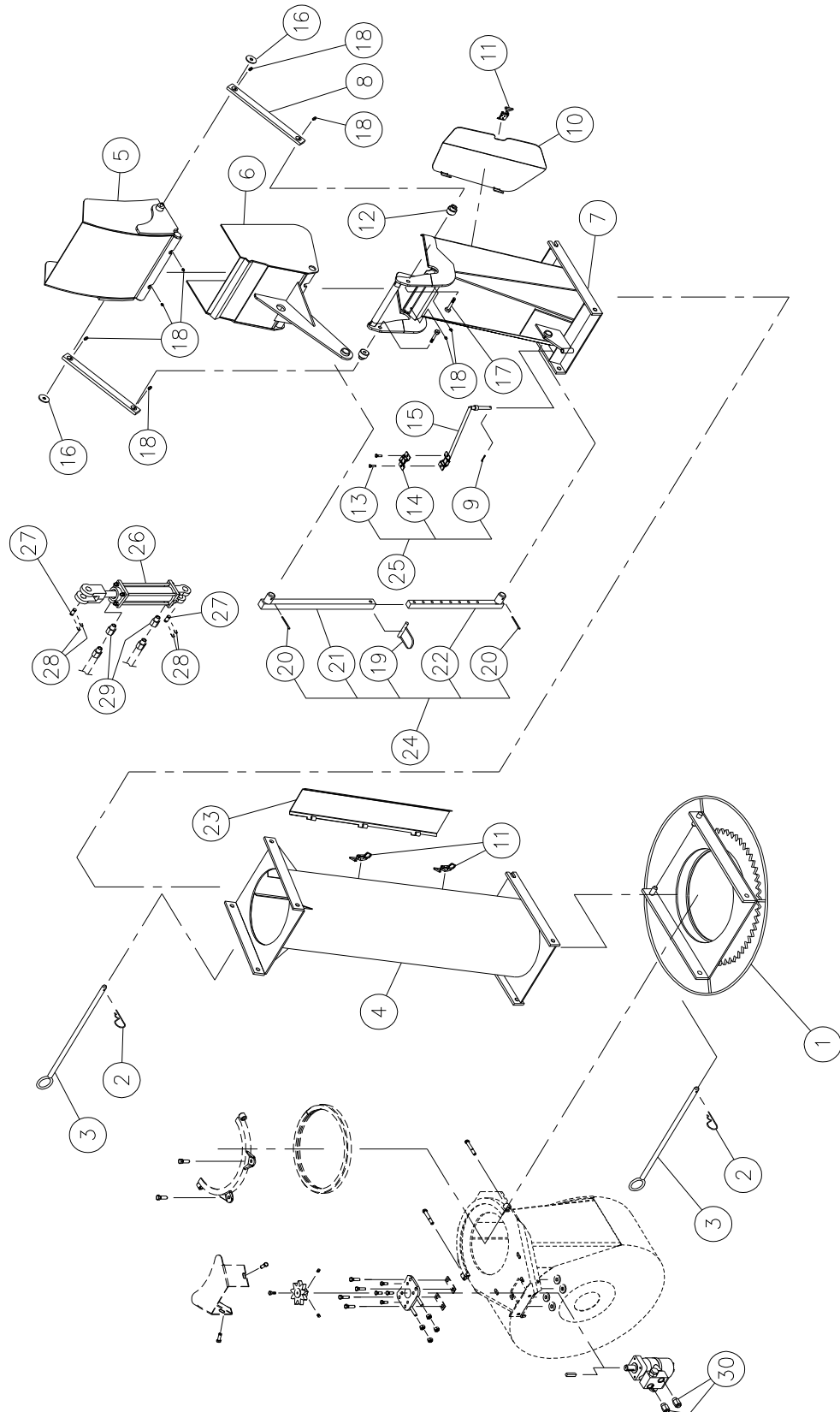

# INDUSTRIAL CHUTE PCG-7486

REF.	PART #	DESCRIPTION	QTY
1	110-04441	Chute adaptor with quick attach .....	1
2	Std.	Hitch pin clip 5/32" .....	2
3	8200	Pin for quick attach (adaptor & extension) .....	2
4	110-22961	Extension 48" PRP-7486 .....	opt.
4	110-23051	Extension 24" PRP-7486-2 .....	opt.
5	110-22511	Upper deflector .....	1
6	110-22521	Lower deflector .....	1
7	110-22564	Chute base .....	1
8	140-14041	Connection rod .....	2
9	Std.	Cotter pin 1/8" x 1" lg .....	1
10	110-45611	Access panel .....	1
11	8376	Adjustable clamp fastener (welded) .....	1
12	150-05311	Spacer for connection rod .....	2
13	300-32250	Bolt 1/4" NC x 1" lg. + nylon locknut .....	2
14	140-13071	Hoses mounting plate .....	1
15	110-01112	Mounting support plate .....	1
16	378-36500	Washer .....	2
17	300-40380	Bolt 1/2" NC x 2 3/4" lg + nylon locknut & washer .....	2
18	Std.	Grease fitting 1/4"-28 straight .....	8
19	8112	Lock pin 1/4" (1) .....	opt.
20	Std.	Cotter pin 5/32" X 2" lg (2) .....	opt.
21	8146	Chute adjusting tube (1) .....	opt.
22	8145	Chute adjusting rod (1) .....	opt.
23	110-23022	Access panel for extension PRP-7486 .....	opt.
23	110-23062	Access panel for extension PRP-7486-2 .....	opt.
24	T-74104	Manual telescopic tube .....	opt.
25	TSB-74104	Hose support for deflector cylinder .....	opt.
26	25TR08	Cylinder .....	opt.
27	6004	Clevis pin 1" x 3 1/8" lg (2) .....	opt.
28	Std.	Hairpin cotter 7/8" (4) .....	opt.
29	RSP-1/16x06NPT	Kit of 2 unidirectional restrictors 3/8" NPT .....	opt.
29	RSP-1/16x08NPT	Kit of 2 unidirectional restrictors 1/2" NPT .....	opt.
30	RSP-1/16x10ORB	Kit of 2 unidirectional restrictors .....	1

# OPTIONS

170-02025R3

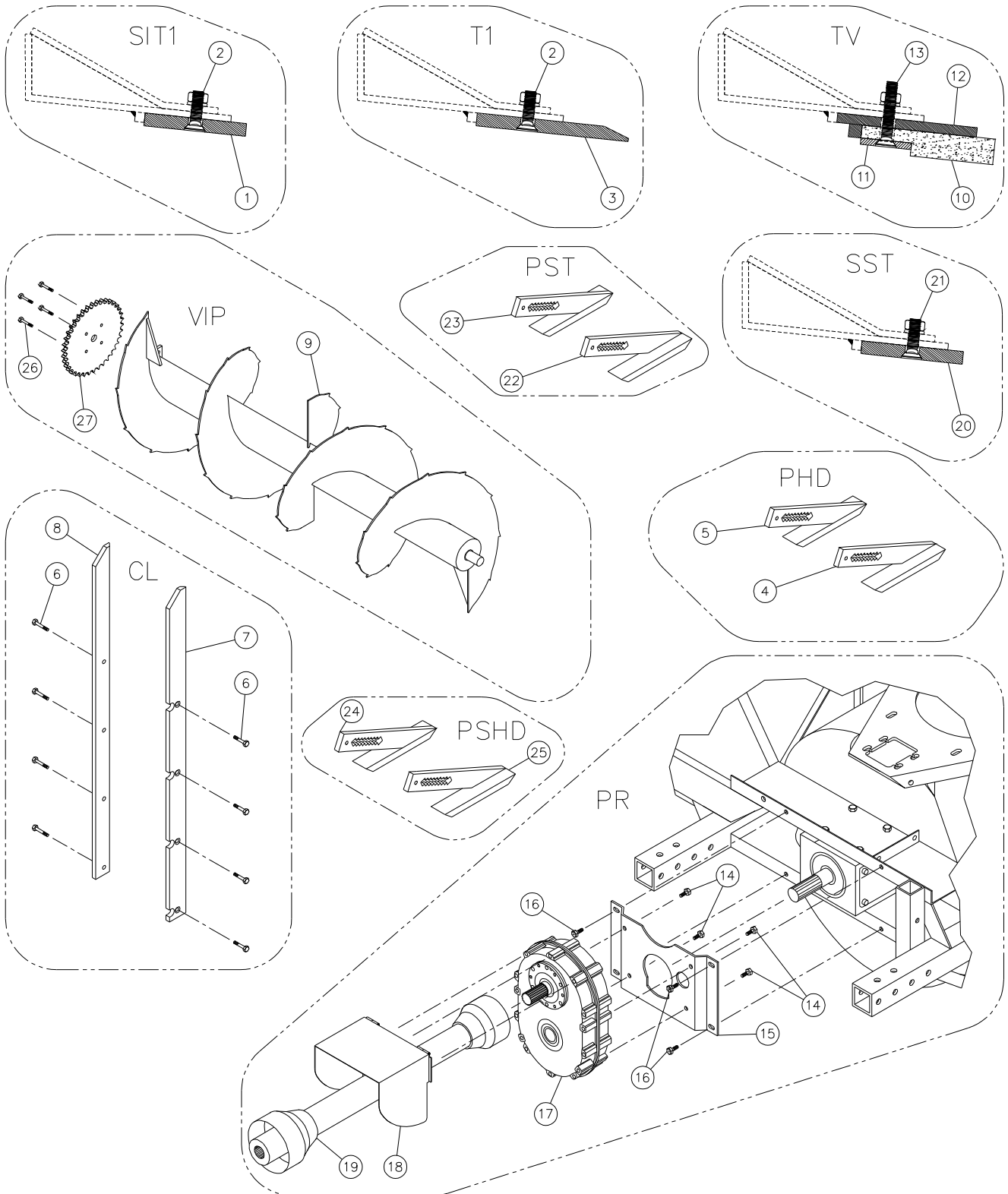



## OPTIONS (cont'd)

REF.	PART #	DESCRIPTION	P-740 (TRC)	P-800 (TRC)	P-860 (TRC)	P-862 (TRC)	P-860 (TRC)-92
			QTY				
1	140-04051	Scraper blade (hard. steel, not sharpened, reversible) 1/2" x 4" x 67 3/4" .....	1	-	-	-	-
1	140-04061	Scraper blade (hard. steel, not sharpened, reversible) 1/2" x 4" x 73 3/4" .....	-	1	-	-	-
1	140-04071	Scraper blade (hard. steel, not sharpened, reversible) 1/2" x 4" x 79 3/4" .....	-	-	1	1	-
1	140-13131	Scraper blade (hard. steel, not sharpened, reversible) 1/2" x 4" x 85 3/4" .....	-	-	-	-	1
2	319-383 10	Flow bolt 7/16" NCx 1-1/2" lg+ nut & lock washer .....	7	8	8	8	9
3	140-04111	Scraper blade (hardened steel, sharpened, not reversible) 1/2" x 6" x 67 3/4" .....	1	-	-	-	-
3	140-04121	Scraper blade (hardened steel, sharpened, not reversible) 1/2" x 6" x 73 3/4" .....	-	1	-	-	-
3	140-04131	Scraper blade (hardened steel, sharpened, not reversible) 1/2" x 6" x 79 3/4" .....	-	-	1	1	-
3	140-13141	Scraper blade (hardened steel, sharpened, not reversible) 1/2" x 6" x 85 3/4" .....	-	-	-	-	1
4	110-05501	Carbon steel skid shoe (right side) .....	1	1	1	1	1
5	110-04681	Carbon steel skid shoe (left side) .....	1	1	1	1	1
6	319-38310	Flow bolt 7/16" NC x 1 1/2" lg+ nut & lock washer .....	8	8	8	8	8
7	130-08291	Lateral blade (right side) .....	1	1	1	-	1
7	130-08301	Lateral blade (right side) .....	-	-	-	1	-
8	130-08292	Lateral blade (left side) .....	1	1	1	-	1
8	130-19271	Lateral blade (left side) .....	-	-	-	1	-
9	110-13901	Full flight spiked auger .....	1	-	-	-	-
9	110-13911	Full flight spiked auger .....	-	1	-	-	-
9	110-13921	Full flight spiked auger .....	-	-	1	1	-
9	110-20841	Full flight spiked auger .....	-	-	-	-	1
10	190-03431	Scraper blade, TIVAR not reversible 1" x 5 1/4" x 67 3/4" .....	1	-	-	-	-
10	190-03501	Scraper blade, TIVAR not reversible 1" x 5 1/4" x 73 3/4" .....	-	1	-	-	-
10	190-01311	Scraper blade, TIVAR not reversible 1" x 5 1/4" x 79 3/4" .....	-	-	1	1	-
10	190-05681	Scraper blade, TIVAR not reversible 1" x 5 1/4" x 85 3/4" .....	-	-	-	-	1
11	140-09341	TIVAR blade bolting plate 1/4" x 2" x 67 3/4" .....	1	-	-	-	-
11	140-09681	TIVAR blade bolting plate 1/4" x 2" x 73 3/4" .....	-	1	-	-	-
11	140-03971	TIVAR blade bolting plate 1/4" x 2" x 79 3/4" .....	-	-	1	1	-
11	140-13151	TIVAR blade bolting plate 1/4" x 2" x 85 3/4" .....	-	-	-	-	1
12	110-12971	TIVAR blade holder 3/8" x 5 1/2" x 67 3/4" .....	1	-	-	-	-
12	110-13641	TIVAR blade holder 3/8" x 5 1/2" x 73 3/4" .....	-	1	-	-	-
12	110-08321	TIVAR blade holder 3/8" x 5 1/2" x 79 3/4" .....	-	-	1	1	-
12	110-20581	TIVAR blade holder 3/8" x 5 1/2" x 85 3/4" .....	-	-	-	-	1
13	319-38370	Flow bolt 7/16" NCx 2 1/2" lg+ nut & lock washer .....	7	8	8	8	9
14	300-40280	Bolt 1/2" NCx 1 1/4" lg+ nut & lock washer .....	4	4	4	4	4
15	130-16683	Mounting plate for speed reducer 1000@540 "left" .....	1	1	1	1	1
16	300-40310	Bolt 1/2" NCx 1 1/2" lg+ nylon locknut & flat washer (x) .....	4	4	4	4	4
17	8348	Speed reducer 1000@540 "triple chain" .....	1	1	1	1	1
18	110-12961	PTO shroud for speed reducer 1000@540 .....	1	1	1	1	1
19	8202-1	P.T.O T60, QD 1 3/8"-21 splines, SBI 1 3/8"-6 .....	1	1	1	1	1
20	140-15001	Scraper blade (stainless steel, not sharpened, reversible) 1/2" x 4" x 67 3/4" .....	1	-	-	-	-
20	140-15011	Scraper blade (stainless steel, not sharpened, reversible) 1/2" x 4" x 73 3/4" .....	-	1	-	-	-
20	140-15021	Scraper blade (stainless steel, not sharpened, reversible) 1/2" x 4" x 79 3/4" .....	-	-	1	1	-

# OPTIONS (cont'd)

REF.	PART #	DESCRIPTION	P-740(TRC)	P-800(TRC)	P-860(TRC)	P-862(TRC)	P-860(TRC)-92
			QTY				
20	140-15031	Scraper blade (stainless steel, not sharpened, reversible) 1/2" x 4" x 85¾" .....	-	-	-	-	1
21	333-40310	Bolt. cyl. head 6 PC 1/2" NC x 1 1/2" lg (inox.) + nut & lock washer .....	opt.	opt.	opt.	opt.	opt.
21	319-38310	Plow bolt 7/16" NC x 1 1/2" lg+ nut & lock washer .....	7	8	8	8	9
22	110-24811	Stainless steel skid shoe (right side) .....	1	1	1	1	1
23	110-24812	Stainless steel skid shoe (left side) .....	1	1	1	1	1
24	110-45761	Skid shoe (left side) with Rocktec sole .....	1	1	1	1	1
25	110-45762	Skid shoe (right side) with Rocktec sole .....	1	1	1	1	1
26	300-38310	Bolt 7/16" NC x 1 1/2" lg + two way locknut .....	4	4	4	4	4
27	8185	Sprocket 80A30 T 1 1/4" .....	1	1	1	1	1

# P.T.O. SHAFT # 8114-EG (T50)

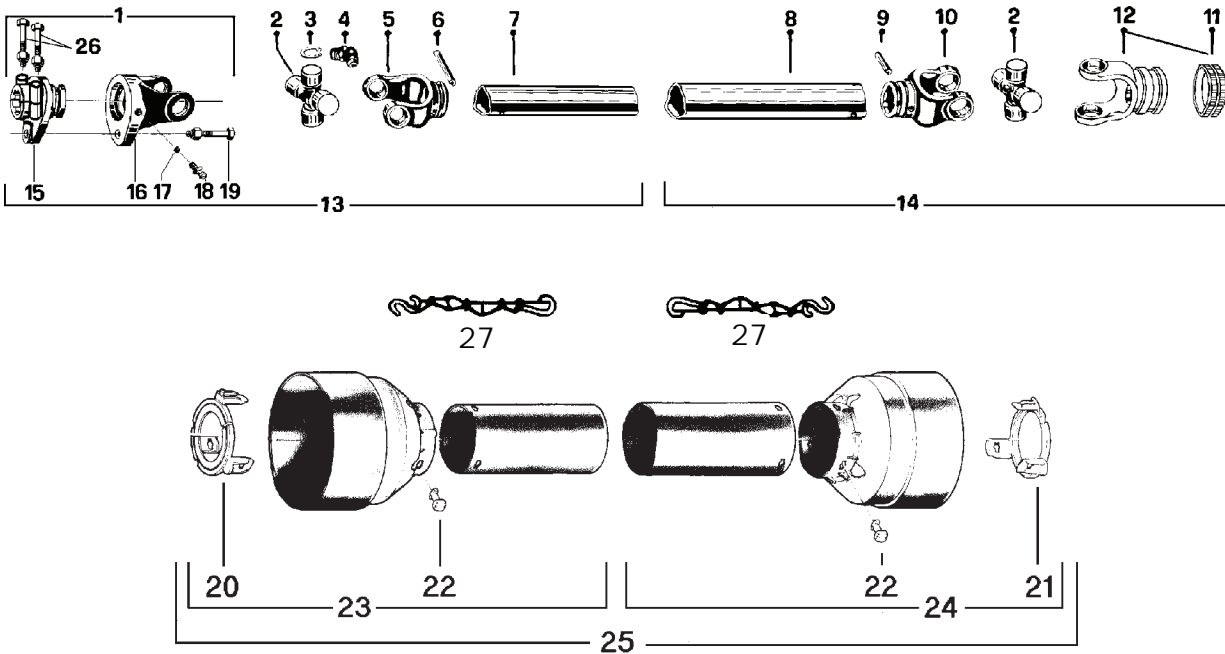

REF.	PART #	DESCRIPTION	QTY
1	8221	Safety shear yoke (2 bolts) .....	1
2	8073	U joint + 4 retaining rings + 1 grease fitting .....	2
3	8061	Retaining ring .....	8
4	8110	Grease fitting .....	2
5	8079	Yoke for inner tube .....	1
6	6341	Stopper for inner tube .....	1
7	8077	Inner tube .....	1
8	8076	Outer tube .....	1
9	8142	Stopper for outer tube .....	1
10	8074	Yoke for outer tube .....	1
11	8363	Collar kit .....	1
12	8113	Yoke with hole 1 3/8"-6 splines + yoke stopper (#11 included) .....	1
13	8235	P.T.O. section, side with safety shear bolt, inner part, with protector .....	1
14	8236	P.T.O. section, side without safety shear bolt, outer part, with protector .....	1
15	8223	Adaptor (2 bolts) .....	1
16	8069	Yoke and shearplate .....	1
17	8070	Ball .....	17
18	8071	Grease fitting .....	1
19	8072	Safety shear bolt M10 x 50mm .....	1
20	8084-E	Bearing ring for inner guard tube .....	1
21	8083-E	Bearing ring for outer guard tube .....	1
22	8109	Stopper .....	6
23	8086	Inner shield .....	1
24	8085	Outer shield .....	1
25	8087	Complete shield .....	1
26	8222	Bolt M12 x 70mm + nylon lock nut .....	2
27	8308	Safety chain .....	2

# P.T.O. SHAFT # 8202 & 8202-1 (T60)

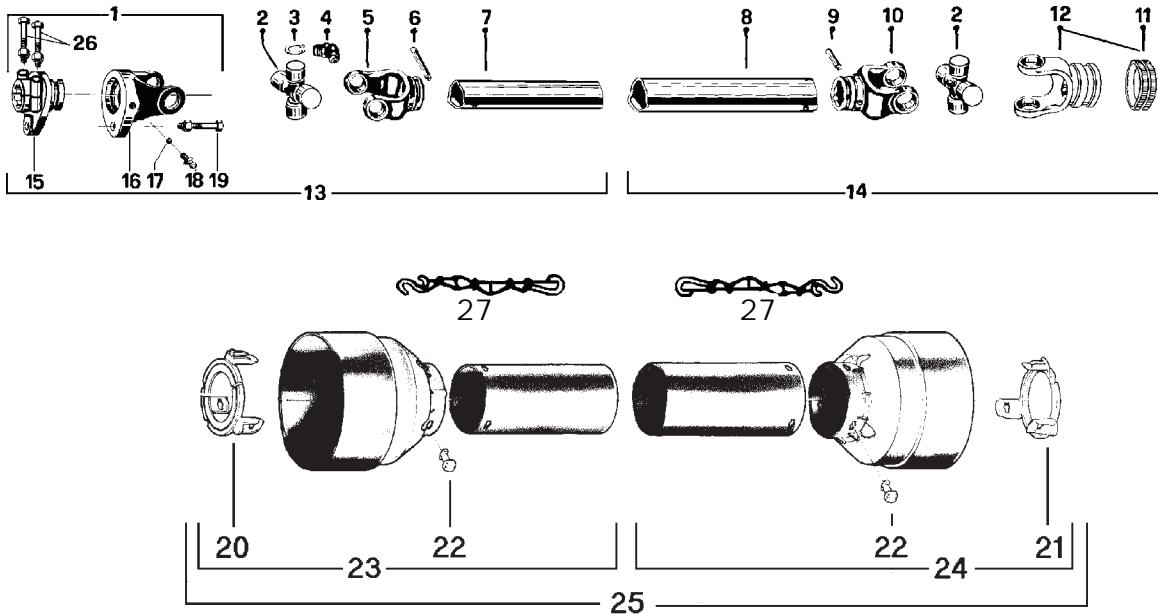

REF.	PART #	DESCRIPTION	8202	8202-1
1	8237	Safety shear yoke (2 bolts) .....	1	1
2	8238	U joint + 4 retaining rings + 1 grease fitting .....	2	2
3	8061	Retaining ring .....	8	8
4	8110	Grease fitting .....	2	2
5	8239	Yoke for inner tube .....	1	1
6	8075	Stopper for inner tube .....	1	1
7	8077	Inner tube .....	1	1
8	9212	Outer tube .....	1	1
9	9210-E	Stopper for outer tube .....	1	1
10	8240	Yoke for outer tube .....	1	1
11	8363	Collar kit .....	1	1
12	8250	Yoke with hole 1 3/8"-6 splines + yoke stopper (#11 included) .....	1	-
12	8250-1	Yoke with hole 1 3/8"-21 splines + yoke stopper (#11 included) .....	-	1
13	8241	P.T.O. section, SBI 1 3/8"-6, inner part, with protector .....	1	1
14	8242	P.T.O. section, QD 1 3/8"-6, outer part, with protector .....	1	-
14	8242-1	P.T.O. section, QD 1 3/8"-21, outer part, with protector .....	-	1
15	8243	Adaptor (2 bolts) .....	1	1
16	8244	Yoke and shearplate .....	1	1
17	9205	Ball .....	17	17
18	8071	Grease fitting .....	1	1
19	8218	Safety shear bolt M10 x 60mm .....	1	1
20	8245	Bearing ring for inner guard tube .....	1	1
21	8246	Bearing ring for outer guard tube .....	1	1
22	8109	Stopper .....	6	6
23	8247	Inner shield .....	1	1
24	8248	Outer shield .....	1	1
25	8249	Complete shield .....	1	1
26	8222	Bolt M12 x 70mm + lock nut .....	2	2
27	8308	Safety chain .....	2	2

# P.T.O. SHAFT # 9225-1 (T80)

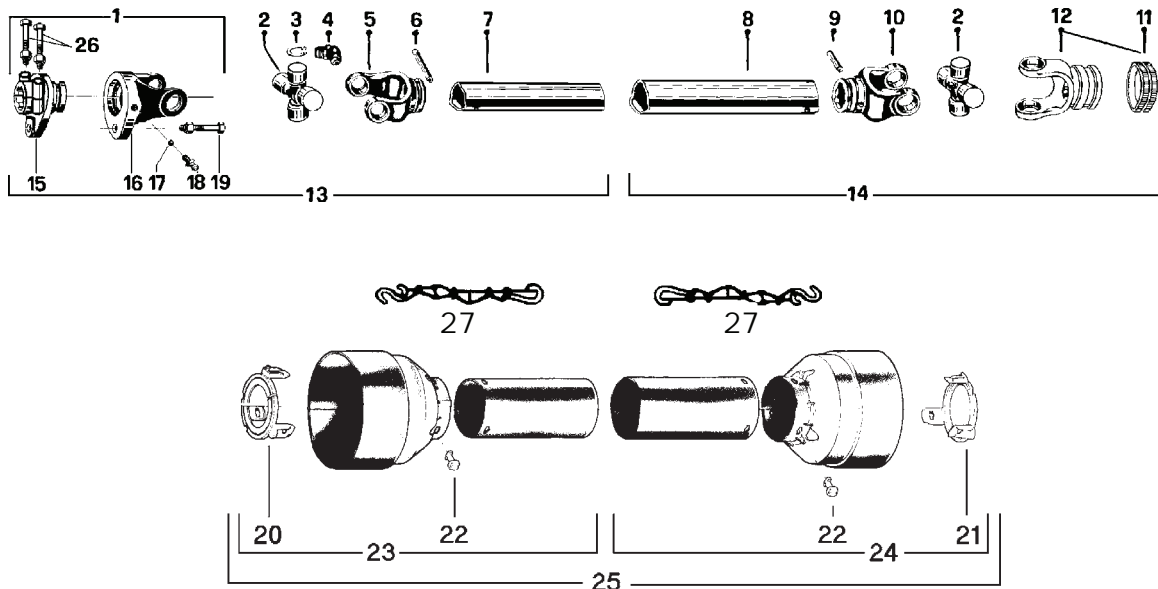

REF.	PART #	DESCRIPTION	QTY
1	9464-2	Safety shear yoke M10 (2 bolts) 1 3/8" - 6 splines .....	1
2	9208	U-joint + 4 retaining rings + 1 grease fitting .....	2
3	9454	Retaining ring .....	8
4	8110	Grease fitting .....	2
5	9214	Yoke for inner tube .....	1
6	8075	Stopper for inner tube .....	1
7	9212	Inner tube .....	1
8	9211	Outer tube .....	1
9	9210-E	Stopper for outer tube .....	1
10	9209	Yoke for outer tube .....	1
11	8363	Collar kit .....	2
12	9455	Yoke with hole 1 3/8"-6 splines + yoke stopper (#11 included) .....	1
13	9456-1	P.T.O. section, SBI 1 3/8"-6, inner part, with protector .....	1
14	9457	P.T.O. section, QD 1 3/8"-6, outer part, with protector .....	1
15	9458-2	Adaptor 1 3/8"-6 splines (2 bolts) (hole 10 mm) .....	1
16	9572	Yoke and shearplate (hole 10 mm) .....	1
17	9205	Ball .....	17
18	8071	Grease fitting .....	1
19	8218	Safety shear bolt M10 x 60 mm .....	1
20	9459	Bearing ring for inner guard tube .....	1
21	9460	Bearing ring for outer guard tube .....	1
22	8109	Stopper .....	6
23	9221	Inner shield .....	1
24	9220	Outer shield .....	1
25	9222	Complete shield .....	1
26	8222	Bolt M12 x 70 mm + lock nut .....	2
27	8308	Safety chain .....	2

# GEAR BOX # 8251 (T27D)

170-05581

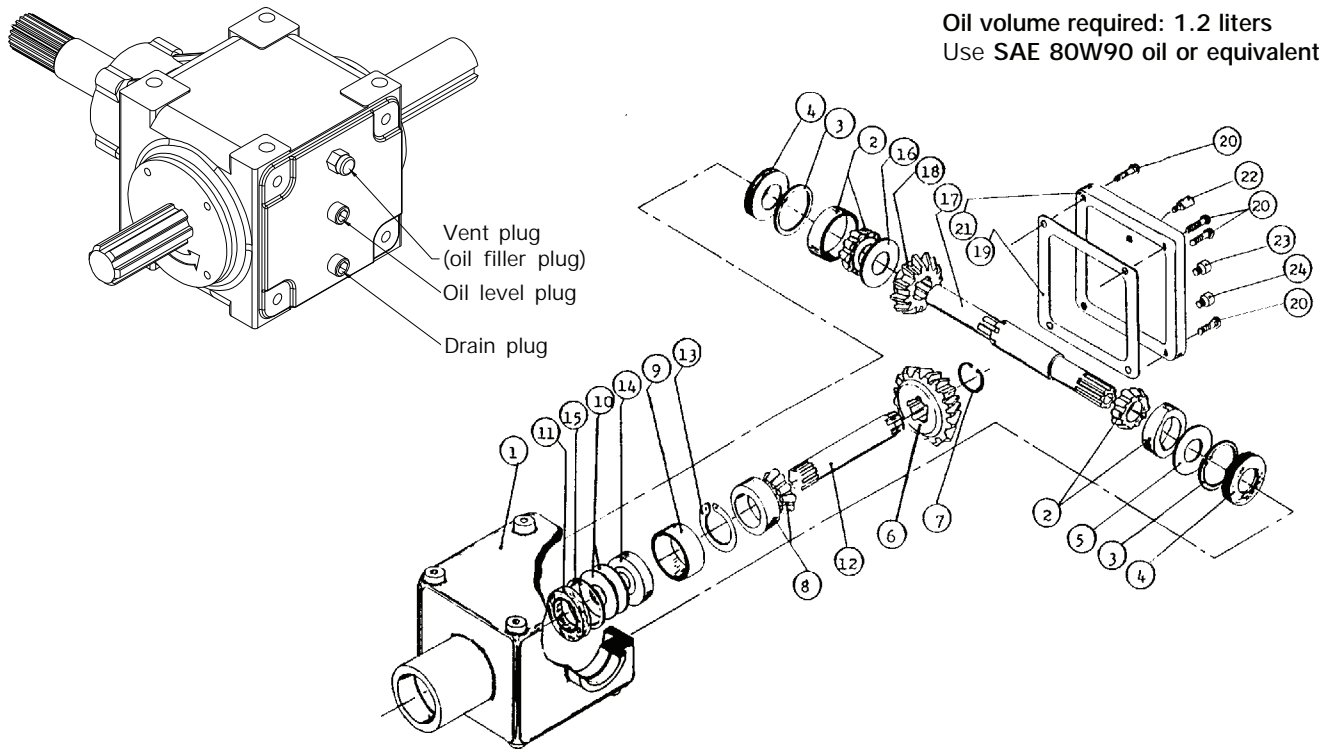

REF.	PART #	DESCRIPTION	QTY
1	8043	Casing .....	1
2	30208-A	Roller bearing .....	2
3	8045	Inside circlip 80mm .....	2
4	8046	Oil seal 40 x 80 x 12mm .....	2
5	8047	Adjusting washer .....	1
6	8048	Gear Z18 .....	1
7	8049	Outside circlip 40mm .....	1
8	30207-A	Roller bearing .....	1
9	8051	Spacer ring .....	1
10	8052	Adjusting washer .....	2
11	8053	Oil seal 35 x 72 x 12mm .....	1
12	8054	Side shaft (1¼" - 19 splines) .....	1
13	8055	Inside circlip 72mm .....	1
14	6207-2RS	Ball bearing .....	1
15	8057	Outside circlip 35mm .....	1
16	8058	Adjusting washer .....	1
17	8252	Impeller shaft (1.575" & 1 3/8" - 6 splines) .....	1
18	8060	Gear Z-18 .....	1
19	- - -	Use silicone caulking .....	-
20	8062	Bolt M10 x 14mm .....	4
21	8063	Cover .....	1
22	8065	Vent plug (oil filler plug) .....	1
23	8064	Plug (oil level) .....	1
24	8064	Plug (oil drain) .....	1

# REDUCTION GEAR BOX # 8348

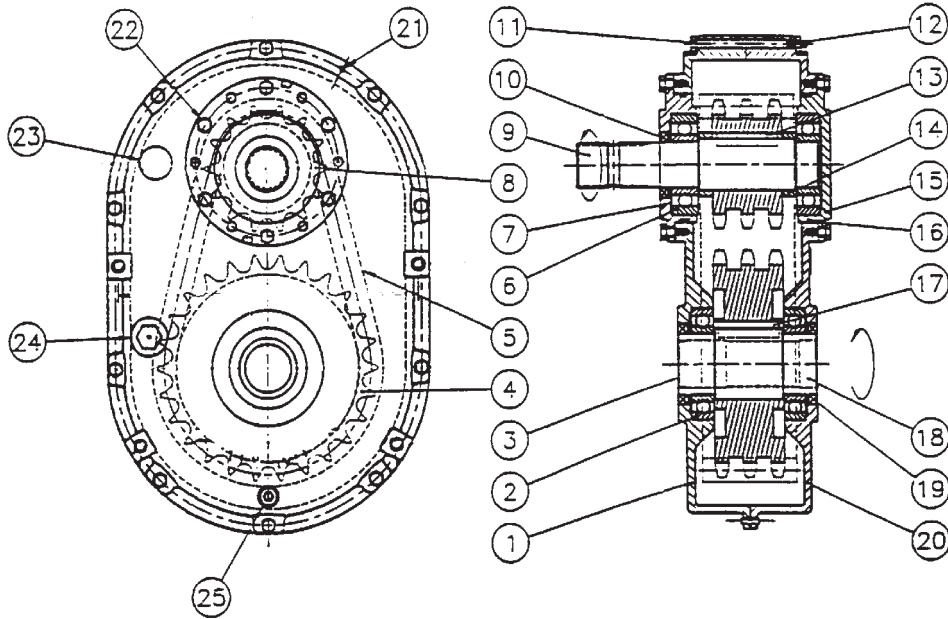

REF.	PART #	DESCRIPTION	QTY
1	9546	Casing with plug .....	1
2	6212-RS	Bearing 6212 .....	2
3	9547	Seal cover (47 x 7) .....	1
4	9548	Sprocket 80-3A26 .....	1
5	9549	Chain 80-3 x 36" lg .....	1
6	6309-RS	Bearing 6309 .....	2
7	9550	Input cover with hole .....	1
8	9551	Sprocket 80-3A14 .....	1
9	8349	Input shaft 1 3/8"-6 splines .....	1
10	9553	Oil seal (45x65x8) TC double lips .....	1
11	300-34490	Bolt 5/16" NC x 4 1/2" lg .....	10
12	336-34000	Nut 5/16" NC .....	10
13	9554	Square key 1/2" x 2 1/2" .....	1
14	9555	Spacer (2 - 2 3/8 - 0.568) .....	2
15	9556	Input cover w/o hole .....	1
16	9557	O-ring AS-248 .....	2
17	9558	Square key 5/8" x 2 1/2" .....	1
18	8350	Output shaft 1 3/8"-6 splines .....	1
19	9560	Oil seal (60 x80x10) TC double lips .....	2
20	9561	Casing w/o plug .....	1
21	9562	Slotted spring pin 3/16" x 3/4" .....	2
22	300-30220	Bolt 3/16" NC x 3/4" lg .....	12
23	9563	Air vent 1/2" NPT .....	1
24	9564	Sight glass 3/4" NPT (oil level) .....	1
25	9565	Drain plug 1/2" NPT .....	1



# CYLINDER 25TR08

15050

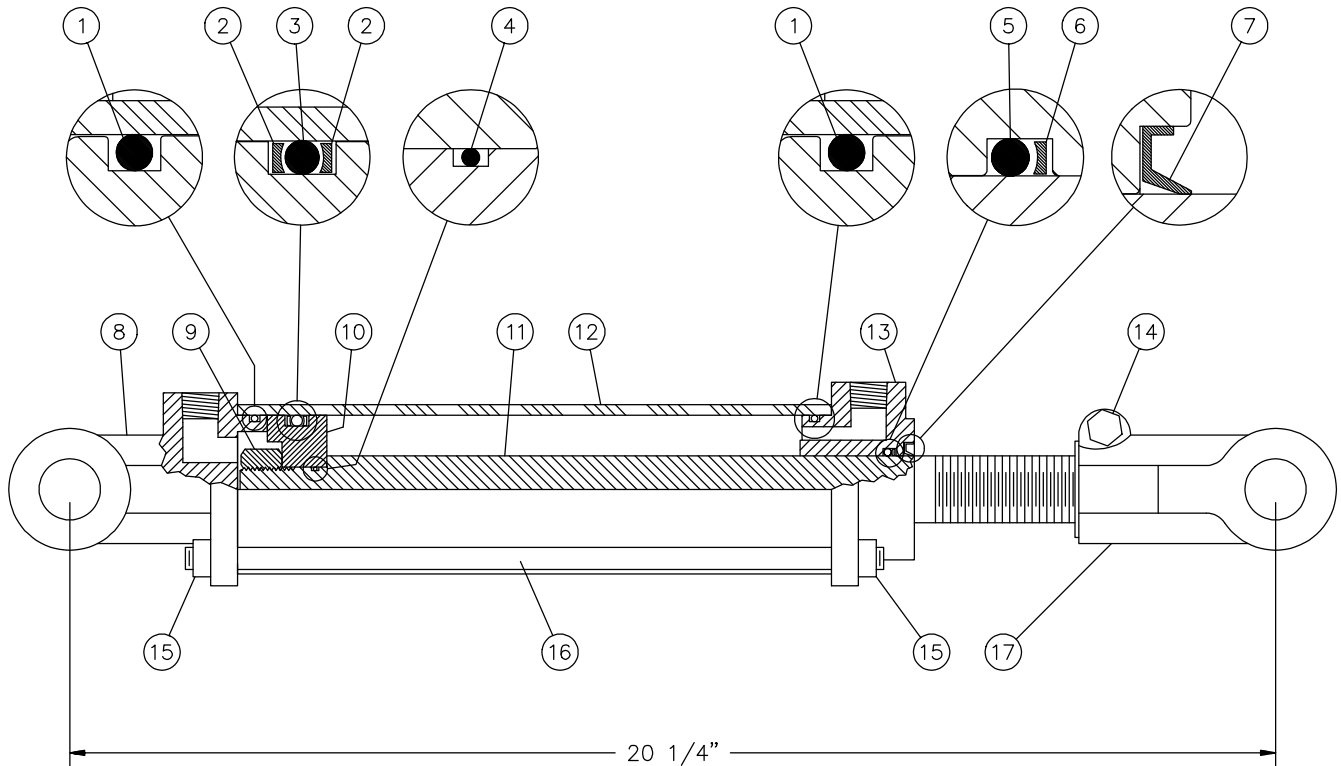

REF.	PART #	DESCRIPTION	QTY
1	See #RK25TR	O-ring 1/8" x 2 1/4" x 2 1/2" .....	2
2	See #RK25TR	Back-up 2 1/2" o.d. x 3/16 ø .....	2
3	See #RK25TR	O-ring 3/16" x 2 1/8" x 2 1/2" .....	1
4	See #RK25TR	O-ring 1/16" x 5/8" x 3/4" .....	1
5	See #RK25TR	O-ring 1/8" x 1 1/8" x 1 3/8" .....	1
6	See #RK25TR	Back-up 1 3/8" o.d. x 1/8" ø .....	1
7	See #RK25TR	Wiper 1 1/8" i.d. x 1 5/8" o.d. ....	1
8	492401	Yoke (for 2 1/2" tube) .....	1
9	338-46000	Nut 3/4" NF .....	1
10	4924-31	Piston 2 1/2" ø .....	1
11	492028	Piston rod 1 1/8" .....	1
12	491668	Cylinder body 2 1/2" ø .....	1
13	492421	Head (for 2 1/2" tube) .....	1
14	300-36355	Bolt 3/8" NC x 2 1/4" + nut .....	1
15	336-36000	Nut 3/8" NC .....	8
16	Std.	Threaded rod 3/8" NC x 12" lg .....	4
17	458599	Yoke (for 1 1/8" rod) .....	1
NI*	8183	Pin 1" ø + cotter pin .....	2
NI*	RK25TR	Repair kit for cylinder 2 1/2" (includes # 1, 2, 3, 4, 5, 6, & 7) .....	1

\*NI = NOT ILLUSTRATED

# HYDRAULIC MOTOR # MLH-250 & MLH-315

## CUSHION VALVE H110

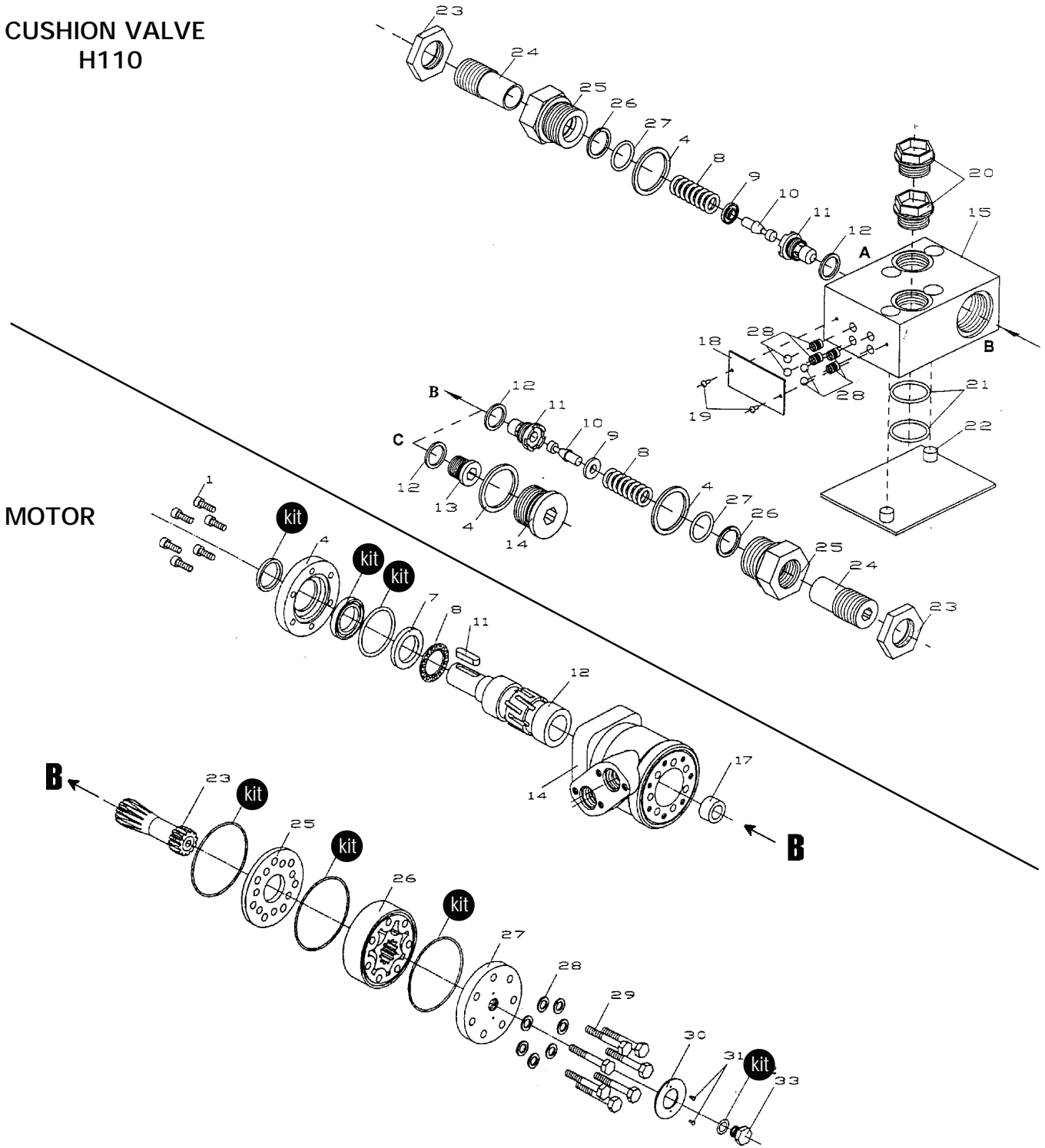







REF.	PART #	DESCRIPTION	QTY
kit	8368	Set of seals.....	1
11	8369	Key for "Orbit" motor.....	1





# TORQUE CHART

11

## TORQUE SPECIFICATION TABLE

Thread UNC and UNF		Grade 2 				Grade 5   				Grade 8*   			
Bolt size		Torque				Torque				Torque			
Inches	mm	Pound feet		Newton meters		Pound feet		Newton meters		Pound feet		Newton meters	
		min.	max.	min.	max.	min.	max.	min.	max.	min.	max.	min.	max.
1/4	6.35	5	6	6.8	8.13	9	11	12.2	14.9	12	15	16.3	30.3
5/16	7.94	10	12	13.6	16.3	17	20.5	23.1	27.8	24	29	32.5	39.3
3/8	9.53	20	23	27.1	31.2	35	42	47.5	57.0	45	54	61.0	73.2
7/16	11.11	30	35	40.7	47.4	54	64	73.2	86.8	70	84	94.9	113.9
1/2	12.70	45	52	61.0	70.5	80	96	108.5	130.2	110	132	149.2	179.0
9/16	14.29	65	75	88.1	101.6	110	132	149.2	179.0	160	192	217.0	260.4
5/8	15.88	95	105	128.7	142.3	150	180	203.4	244.1	220	264	298.3	358.0
3/4	19.05	150	185	203.3	250.7	270	324	366.1	439.3	380	456	515.3	618.3
7/8	22.23	160	200	216.8	271.0	400	480	542.4	650.9	600	720	813.6	976.3
1	25.40	250	300	338.8	406.5	580	696	786.5	943.8	900	1080	1220.4	1464.5
1 1/8	25.58	-	-	-	-	800	880	1084.8	1193.3	1280	1440	1735.7	1952.6
1 1/4	31.75	-	-	-	-	1120	1240	1518.7	1681.4	1820	2000	2467.9	2712.0
1 3/8	34.93	-	-	-	-	1460	1680	1979.8	2278.1	2380	2720	3227.3	3688.3
1 1/2	38.10	-	-	-	-	1940	2200	2630.6	2983.2	3160	3560	4285.0	4827.4

\* Thick nuts must be used with grade 8 bolts.

Size of screw	Thread	Pitch (mm)	Grade 4T  				Grade 7T 				Grade 8T  			
			Torque				Torque				Torque			
			Pound feet		Newton meters		Pound feet		Newton meters		Pound feet		Newton meters	
		min.	max.	min.	max.	min.	max.	min.	max.	min.	max.	min.	max.	
M6	UNC	1.00	3.6	5.8	4.9	7.9	5.8	9.4	7.9	12.7	7.2	10	9.8	13.6
M8	UNC	1.25	7.2	14	9.8	19	17	22	23	29.8	20	26	27.1	35.2
M10	UNC	1.5	20	25	27.1	33.9	34	40	46.1	54.2	38	46	51.5	62.3
M12	UNC	1.75	28	34	37.9	46.1	51	59	69.1	79.9	57	66	77.2	89.4
M14	UNC	2.0	49	56	66.4	75.9	81	93	109.8	126	96	109	130.1	147.7
M16	UNC	2.0	67	77	90.8	104.3	116	130	157.2	176.2	129	145	174.8	196.5
M18	UNC	2.0	88	100	119.2	136	150	168	203.3	227.6	175	194	237.1	262.9
M20	UNC	2.5	108	130	146.3	176.2	186	205	252	277.8	213	249	288.6	337.4
M8	UNF	1.0	12	17	16.3	23	19	27	25.7	36.6	22	31	29.8	42
M10	UNF	1.25	20	29	27.1	39.3	35	47	47.4	63.7	40	52	54.2	70.5
M12	UNF	1.25	31	41	42	55.6	56	68	75.9	92.1	62	75	84	101.6
M14	UNF	1.5	52	64	70.5	86.7	90	106	122	143.6	107	124	145	168
M16	UNF	1.5	69	83	93.5	112.5	120	138	162.6	187	140	158	189.7	214.1
M18	UNF	1.5	100	117	136	158.5	177	199	239.8	269.6	202	231	273.7	313
M20	UNF	1.5	132	150	178.9	203.3	206	242	279.1	327.9	246	289	333.3	391.6

Use the above torques when special torque is not given.

NOTE: These values apply to fasteners as received from supplier, dry, or when lubricated with normal engine oil. They do not apply if extreme pressure lubricants are used.

---

---

## WARRANTY

---

PRONOVOST warrants this product to the initial purchaser for the period of one year from the date of purchase against defects in materials and workmanship.

We will replace or repair defective parts free of charge if they are returned to our plant in St-Tite, Quebec, Canada.

Transportation charges are the responsibility of the customer. This warranty is not transferable.

Hydraulic cylinders and motors are covered by the manufacturer of these items.

The PTO shafts are warranted by the manufacturer and cover **only** defects in material and workmanship, and is conditional to recommended use and installation only.

All PRONOVOST spare parts purchased are covered by a three (3) month warranty.

This warranty becomes void and nul if the equipment is modified, breaks down as the result of an accident, is not operated according to manufacturer's recommendations, damaged by negligence or if maintenance has not been carried out as specified.

Our obligation is limited to the replacement or repair of the defective part. PRONOVOST accepts no responsibility for direct or indirect consequential damages of any kind.











Ce manuel est aussi disponible en français.  
Veuillez téléphoner.



INNOVATION - EXCELLENCE

**LES MACHINERIES PRONOVOST INC.**  
260, Haut du Lac Sud (route 159),  
Saint-Tite, Quebec, Canada, G0X 3H0  
Tel.: (418) 365-7551, Fax: (418) 365-7954  
[www.pronovost.qc.ca](http://www.pronovost.qc.ca)