



## **OPERATOR'S / PARTS MANUAL**

**P-1624&P-1824**

**P-1648&P-1848**

**P-1672&P-1872**



**P-51624&P-51824**

**P-51648&P-51848**

**P-51672&P-51872**

### ***Dumping forage and grain box***

- For running gear mounting**
- Tandem trailer mounted**



Copyright © Les Machineries Pronovost Inc., 2001

All rights reserved.  
Printed in Canada.

---

---

# TABLE OF CONTENTS

---

---

Section	Item	Page
1	<b>Introduction</b> .....	5
2	<b>Safety</b> .....	6
	General Safety .....	6
	Safety in Operation .....	6
	Safety with Maintenance .....	7
	Safety in Transport .....	7
	Safety in Storage .....	7
3	<b>Decals</b> .....	8
	Maintenance Decals .....	8
4	<b>Start-up</b> .....	9
	Basic Start-up Procedures .....	9
5	<b>Maintenance</b> .....	10
6	<b>Storage</b> .....	11
7	<b>Specifications</b> .....	12
8	<b>Parts List</b> .....	12
	Dumping Box P-1624 & P-1824 .....	14
	Dumping Box P-51624 & P-51824 .....	16
	Dumping Box P-1648 & P-1848 .....	19
	Dumping Box P-51648 & P-51848 .....	21
	Dumping Box P-1672 & P-1872 .....	24
	Dumping Box P-51672 & P-51872 .....	27
	Canvas roof & galvanized steel roof .....	30
	Telescopic cylinder #110-00471 .....	31
	Hub H8001 .....	32
9	<b>Torque chart</b> .....	33
10	<b>Garantie</b> .....	34



---

---

# INTRODUCTION

---

1

## CONGRATULATIONS!

Thank you for choosing PRONOVOST. We are confident this equipment will meet your requirements in terms of quality, performance and reliability.

This manual was prepared to assist you in the safe operation of your new Dumping Box. It contains important information which will help you achieve excellent returns with your PRONOVOST Dumping Box for years to come.

Please read this manual before operating your Dumping Box and keep it for future reference.

Before using this equipment, you or any other person who will be using it must familiarize yourself with the safety recommendations, the operating and safety instructions. Please read carefully and be sure to understand and follow all recommendations and procedures.

In this manual, the right and left sides are identified while standing at the rear end of the equipment and facing it.

If you require additional information on your Dumping Box, please contact your PRONOVOST Dealer.

**NOW** take a moment to enter the model, serial number and the date of purchase of your Dumping Box in the space provided below.

When ordering parts from your Dealer, please refer to these numbers for a fast and efficient service. Use PRONOVOST parts for replacement.

The model and serial numbers are on the name plate shown on Fig. 1.



Figure 1

MODEL: \_\_\_\_\_ ✍

SERIAL NO: \_\_\_\_\_ ✍

DATE OF PURCHASE: \_\_\_\_\_ ✍

---

---

# ***SAFETY***

---

## ***GENERAL SAFETY***

**2**

### **WHEN YOU SEE THIS SYMBOL**



**ATTENTION!**

**BE ALERT  
YOUR SAFETY IS INVOLVED**

This symbol "**SAFETY ALERT**" is used in this manual and on the safety decals on the Dumping Box. It warns you of the possibility of danger. Carefully read, understand and follow all safety recommendations before operating the equipment.

- 1) Careful operation is the best assurance against accidents. Carefully read this manual and follow all recommendations before operating this equipment. It is the owner's responsibility to make sure that anyone who will operate the Dumping Box will read this manual before operating the equipment.
- 2) Do not modify the equipment. Any non authorized modification may affect the efficiency and/or safety of the equipment.
- 3) Never operate the equipment with defective parts or if damaged in any way. Have it repaired before using it.
- 4) Make sure all fasteners are in place and properly secured or tightened. Refer to torque chart on page 33.

- 5) Hydraulic fluids under pressure can damage your skin. Do not use your hands to locate a leak.

## ***SAFETY IN OPERATION***

- 1) **WARNING!** Do not overload your trailer, do not exceed the load capacity indicated in the specifications on page 12 and 13.
- 2) Be sure there are no obstructions around the equipment and that no one stands near the equipment when in use.
- 3) Do not operate an engine in a confined or non ventilated area.
- 4) Do not perform any adjustments, cleaning, maintenance or repairs with the engine running on the towing vehicle. Preferably remove the key from the ignition.
- 5) Be careful when backing-up, make sure you have good visibility.
- 6) Before dumping, make sure that the rear panel is unlocked.
- 7) Always travel at a safe operating speed following regulations and common sense. In the case of agricultural service tires, follow the manufacturer's specified safe speed. The road speed should be such as to maintain full control over steering and braking.

---

---

## ***SAFETY (cont'd)***

---

### ***SAFETY WITH MAINTENANCE***

- 1) Perform maintenance according to recommendations contained in this manual.
- 2) **Before performing any work under the raised platform, always install the safety support provided.**
- 3) If the Dumping Box is hooked up to the tractor while performing maintenance work, make sure the engine is not running and preferably remove the ignition key.

### ***SAFETY IN TRANSPORT***

- 1) On public roads, use proper safety lights and check local regulations.
- 2) Be alert while driving on the road. Never carry passengers.

**2**

---

---

# DECALS

---

## SAFETY DECALS

The safety decals are affixed wherever special safety precautions are indicated. Locate them on the equipment and read them carefully. If a decal is damaged, lost or illegible, install a new one. The following photos indicate where each one must be installed.

**3**

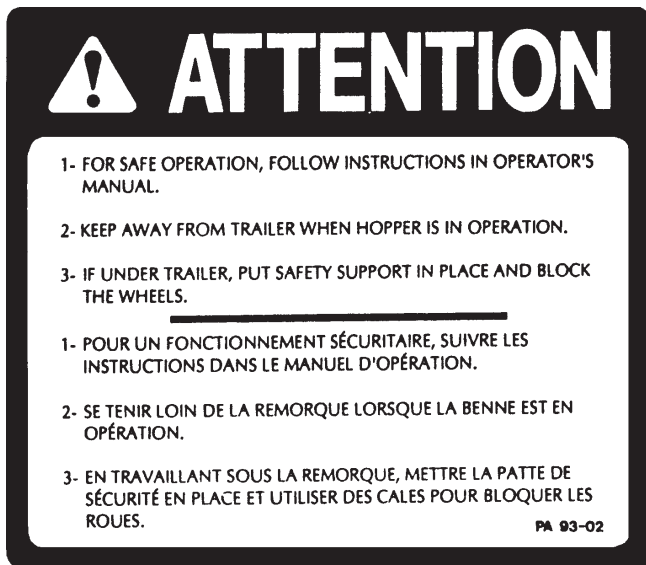

Figure 2  
Decal A

Part no.: A110



Figure 3

## MAINTENANCE DECALS

The maintenance decals indicate the points requiring lubrication. Refer to maintenance section for more details.

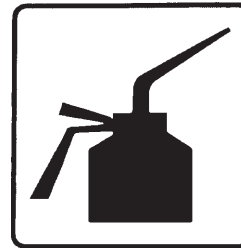

Figure 4

Part no.: A 105



Figure 5

Part no.: A 106



---

---

# ***START-UP***

---

## ***BASIC START-UP PROCEDURES***

- 1) It is recommended to install the Dumping box P-1672 or P-1872 on a 15 tons - 4 wheels wagon with front equalizer bolster.
- 2) Adjust tire pressure to manufacturer's specifications.
- 3) Install wheels on hubs.
- 4) Set the bolster stakes to obtain 42 1/2" of distance on the inside of the stakes.
- 5) Set the reaches to get 138" wheel-base for the P-1672 and 162" wheel-base for the P-1872.
- 6) Install the platform on the wagon. The platform must exceed the base by about 25" in the front.
- 7) Verify and make sure the platform will not rub against the back wheels when unloading.
- 8) To insure the tires will not rub against the platform, with some models of wagons, you should raise the platform (front and rear) with steel raisers. These raisers should provide sufficient clearance for adequate operation and unloading.
- 9) Fasten the platform to the bolsters of the wagon.
- 10) Assemble the box as shown in this manual
- 11) Verify if the back door is working properly and adjust with spacers if need be.
- 12) Verify the length of the wire cables.
- 13) Verify if the release mechanism is working properly and adjust if need be.
- 14) Lubricate all grease fittings with a good quality multipurpose grease.
- 15) Lubricate panel release mechanism with good quality oil.
- 16) Install all hydraulic hoses and fittings compatible with your equipment.
- 17) Verify for adequate tightness of all fastening devices. Refer to torque chart on page 33.
- 18) The single acting cylinder requires only 14.9 litres (3 1/4 gal.) oil for full extension.
- 19) Operate the hydraulic system a few times, raising and lowering the platform in order to remove any trapped air in the system. Then check the oil level in the tractor's hydraulic oil reservoir.

---

---

# *MAINTENANCE*

---

**Before performing any work under the raised platform, always install the safety support provided.**

- 1) Wipe off all grease fittings with a clean cloth before adding grease in order to avoid injecting dirt or sand.
- 2) Repair or replace damaged grease fittings.
- 3) Lubricate all grease fittings every 20 hours of operation.
- 4) Check all bolts on wheels after first 5 hours of operation and then every 50 hours of operation.
- 5) Lubricate panel release mechanism every 20 hours of operation.
- 6) Check tire pressure every 50 hours of operation, adjust according to manufacturer's recommendation indicated on the tires.
- 7) Open, clean and lubricate wheel bearings once a year.
- 8) Check all nuts and bolts once a year. If necessary use torque chart on page 33.

**5**

---

---

## *STORAGE*

---

- 1) Store in a cool, dry place.
- 2) Install wooden blocks under the axles to keep the tires off the ground and cover them if left exposed to the sun.
- 3) Keep all piston rods in the retracted position. This will assure better protection against the elements.
- 4) Clean your trailer.
- 5) Thoroughly inspect all parts of the trailer. Replace or repair worn or defective parts.
- 6) Touch-up or repaint if necessary.
- 7) Lubricate all points before storage.

# SPECIFICATIONS

## DUMPING BOX FOR RUNNING GEAR MOUNTING

MODEL	P-1624	P-1824	P-1648	P-1848	P-1672	P-1872
Capacity without roof (cu. ft.)	242	273	483	545	725	818
Capacity with roof (cu. ft.)	-	-	-	-	885	977
Overall length of box	16'	18'	16'	18'	16'	18'
Front width	All models: 92 1/2"					
Rear width	All models: 94 1/2"					
Overall width	All models: 109"					
Overall height	41"	41"	65"	65"	89"	89"
Overall height with roof	-	-	-	-	113"	113"
Roof section	-	-	-	-	24"	24"
Dumping angle	All models: 53 degrees					
Hydraulic cylinder	All models: telescopic 5 sections					
Oil volume required	All models: 3.93 US gallons - 14.9 litres					
Dimensions of sides panels	24" x 96"	24" x 108"	24" x 96"	24" x 108"	24" x 96"	24" x 108"
Number of panels per box	4	4	8	8	12	12
Grain door	Standard	Standard	Standard	Standard	Option	Option
Steel roof weight (lbs)	-	-	-	-	406	464
Weight (lbs)	4548	4744	5024	5265	5500	5780
Recommended running gear	All models: 12 to 15 tons					

**7**

Design and specifications subject to change without notice.

# SPECIFICATIONS

## TANDEM TRAILER MOUNTED DUMPING BOX

MODEL	P-51624	P-51824	P-51648	P-51848	P-51672	P-51872
Capacity without roof (cu. ft.)	242	273	483	545	725	818
Capacity with roof (cu. ft.)	-	-	-	-	885	977
Overall length of box	16'	18'	16'	18'	16'	18'
Front width	All models: 92 1/2"					
Rear width	All models: 94 1/2"					
Overall width	All models: 109"					
Overall height	71"	71"	95"	95"	119"	119"
Overall height with roof	-	-	-	-	143"	143"
Roof section	-	-	-	-	24"	24"
Dumping angle	All models: 53 degrees					
Hydraulic cylinder	All models: telescopic 5 sections					
Oil volume required	All models: 3.93 US gallons - 14.9 litres					
Dimensions of sides panels	24" x 96"	24" x 108"	24" x 96"	24" x 108"	24" x 96"	24" x 108"
Number of panels per box	4	4	8	8	12	12
Grain door	Standard	Standard	Standard	Standard	Option	Option
Steel roof weight (lbs)	-	-	-	-	406	464
Weight (lbs)	6084	6280	6560	6798	7036	7324
Recommended running gear	All models: Not required					

Design and specifications subject to change without notice.

**7**

# DUMPING BOX P-1624 & P-1824

170-02831

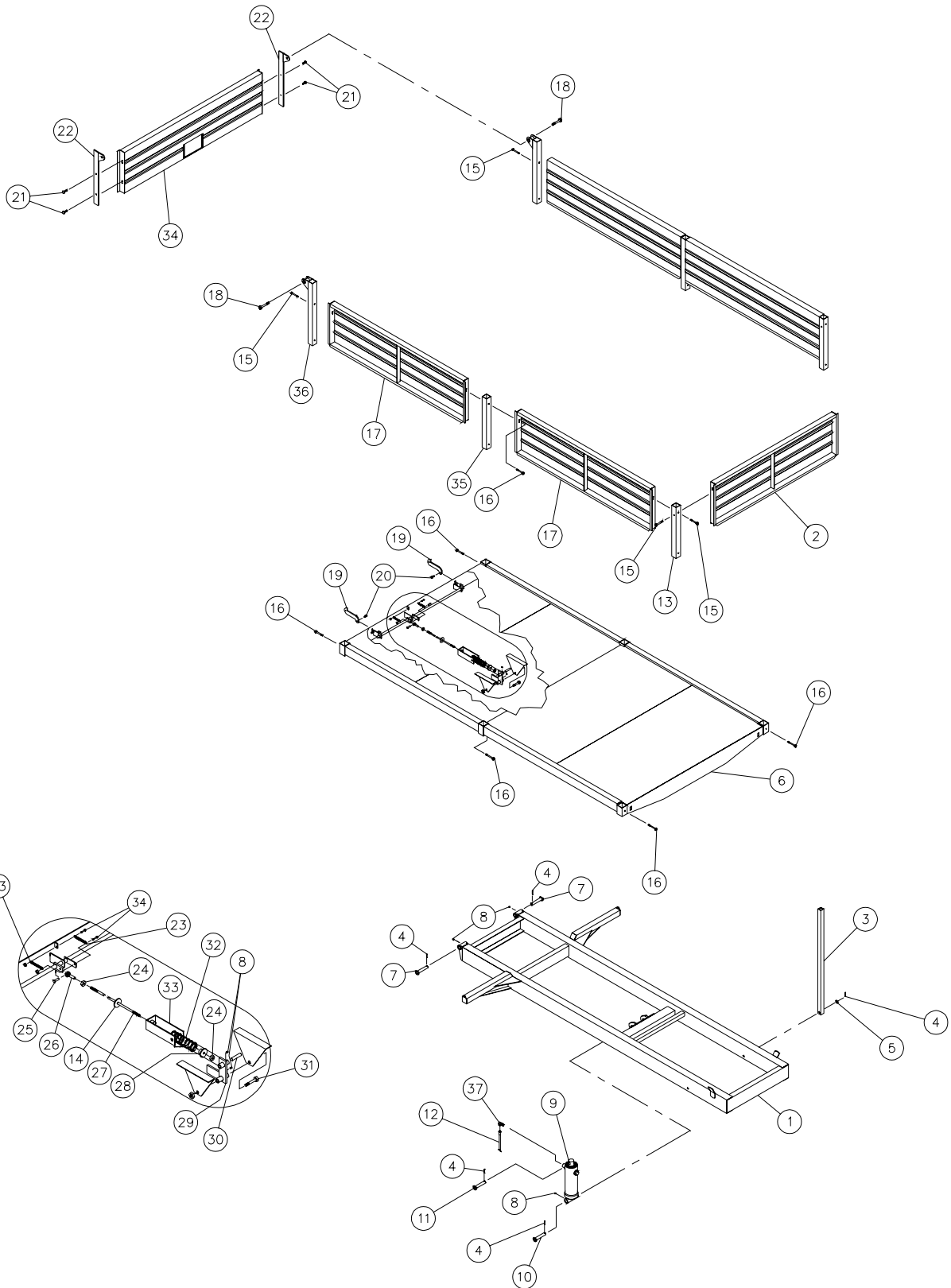

8

# DUMPING BOX P-1624 & P-1824

REF.	PART #	DESCRIPTION	QTY	
			P-1624	P-1824
1	120-03091	Frame .....	1	-
1	120-03101	Frame .....	-	1
2	110-17331	Front panel .....	1	1
3	160-08181	Safety prop .....	1	1
4	Std.	Cotter pin 1/4" x 2" lg .....	5	5
5	Std.	Flat washer 3/4" .....	1	1
6	120-03071	Platform .....	1	-
6	120-03081	Platform .....	-	1
7	110-17421	Clevis pin 1 1/4" x 7" lg .....	2	2
8	Std.	Grease fitting 1/4"-28 droit .....	5	5
9	Std.	Cylinder 5 sections 72" .....	1	1
10	110-00401	Clevis pin for cylinder (at the bottom) 1 1/2" dia. x 10 1/4" lg .....	1	1
11	110-00421	Clevis pin for cylinder (at the top) 1 1/4" dia. x 9 1/8" lg .....	1	1
12	190-04451	Hose 3/8" x 240" lg + 2 fittings 8U108 .....	1	-
12	190-03831	Hose 3/8" x 258" lg + 2 fittings 8U108 .....	-	1
13	160-08551	Frontstack .....	2	2
14	130-23491	Washer .....	1	1
15	Std.	Bolt 7/16" NC x 4" lg + nylon locknut .....	6	6
16	Std.	Bolt 7/16" NC x 4 1/2" lg + nylon locknut .....	8	8
17	110-17341	Side panel .....	4	-
17	110-14901	Side panel .....	-	4
18	Std.	Bolt 3/4" NC x 5" lg + nylon locknut .....	2	2
19	130-09981	Hook .....	2	2
20	Std.	Bolt 1/2" NC x 2" lg + nylon locknut .....	2	2
21	Std.	Plow bolt 7/16" NC x 1 1/2" lg + nylon locknut .....	4	4
22	110-17461	Rear panel support (grain) .....	2	2
23	Std.	Spring B-616 .....	2	2
24	Std.	Nut 1/2"-20NF .....	2	2
25	51436	Clevis pin 1/2" x 1 37/64" lg .....	1	1
26	51435	Yoke 1/2"-20NF .....	1	1
27	110-17431	Rod 1/2" for lock .....	1	-
27	110-14971	Rod 1/2" for lock .....	-	1
28	110-08891	Washer .....	1	1
29	110-08911	Lock assembly pivot .....	1	1
30	150-01811	Clevis pin 3/4" dia. x 3 1/4" lg .....	1	1
31	Std.	Bolt 3/4" NC x 5 1/2" lg + nylon locknut .....	1	1
32	10216	Spring 7/16" x 1 3/4" i.d. x 2 5/8" o.d. x 7 1/2" lg .....	1	1
33	110-08901	Spring holder .....	1	1
34	120-03851	Rear panel (with grain door) .....	1	1
35	160-08541	Centralstack .....	2	2
36	110-17801	Rearstack .....	2	2
37	Std.	Fitting 3/8" -90 degrees swivel .....	1	1



# DUMPING BOX ON TANDEM P-51624 & P-51824

170-02771

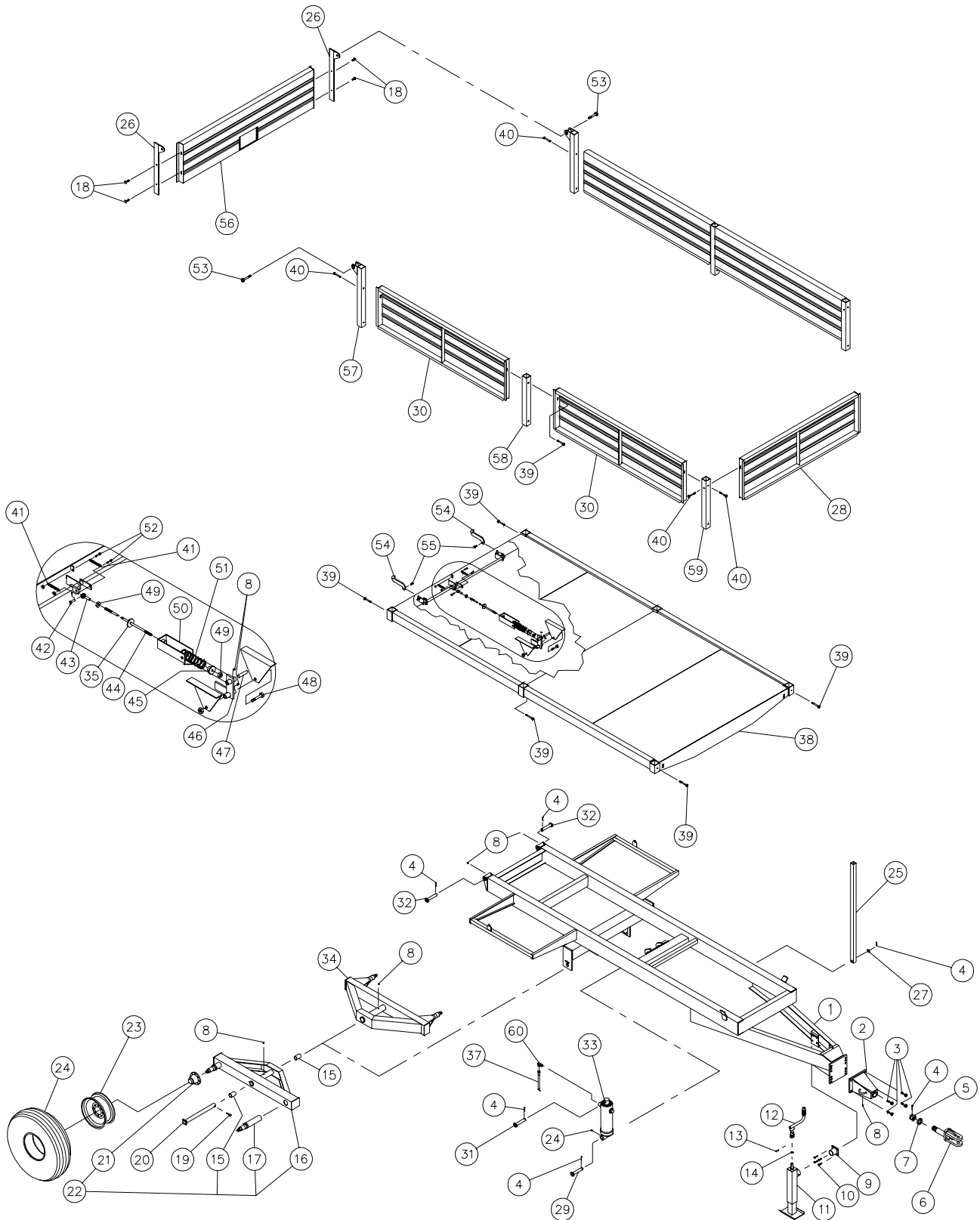

8



# DUMPING BOX ON TANDEM P-51624 & P-51824

REF.	PART #	DESCRIPTION	QTY	
			P-51624	P-51824
1	120-03171	Frame .....	1	-
1	120-03191	Frame .....	-	1
2	120-00141	Hitchassy. ....	1	1
3	Std.	Bolt 3/4" NC x 3" lg + nylon locknut .....	4	4
4	Std.	Cotter pin 1/4" x 3 1/2" lg .....	1	1
5	Std.	Castle nut 1 3/4"-5 NC .....	1	1
6	110-00491	Swivel hitch .....	1	1
7	130-21111	Flat washer 1 13/16" i.d. x 3" o.d. ....	1	1
8	Std.	Grease fitting 1/4"-28 straight .....	8	8
9	110-06411	Jack mounting plate .....	1	1
10	Std.	Bolt 3/4" NC x 3" lg + nylon locknut .....	4	4
11	190-01671	Jack 8000lbs (including #12, #13, #14) .....	1	1
12	190-01672	Hand crank .....	1*	1*
13	Std.	Bolt 1/4" NC x 1" lg + nylon locknut .....	1	1
14	Std.	Ring 1" .....	1	1
15	160-00661	Bushing 1 3/4" d.i. x 2" d.e. x 3" lg .....	4	4
16	110-00443	Right tandem frame .....	1	1
17	150-00211	Axle (welded) .....	4	4
18	Std.	Plow bolt 7/16" NC x 1 1/2" lg + nylon locknut .....	4	4
19	Std.	Bolt 1/2" NC x 3" lg + nylon locknut .....	2	2
20	110-00501	Clevis 1 3/4" dia. x 21 5/8" lg .....	2	2
21	36132	Hub H-8001 assembly .....	4	4
22	110-00444	Right tandem assembly .....	1	1
23	R-161148	Rim 16.1 x 14-8 bolts .....	4	4
24	PN-165161	Tire 16.5 x 16.1-10 plys .....	4	4
25	160-08181	Safety prop .....	1	1
26	110-17461	Rear panel support .....	2	2
27	Std.	Flat washer 3/4" .....	1	1
28	110-17331	Front panel .....	1	1
29	110-00401	Clevis pin for cylinder (at the bottom) 1 1/2" dia. x 10 1/4" lg .....	1	1
30	110-17341	Side panel .....	4	-
30	110-14901	Side panel .....	-	4
31	110-00421	Clevis pin for cylinder (at the top) 1 1/4" dia. x 9 1/8" lg .....	1	1
32	110-17421	Clevis pin 1 1/4" x 7" lg .....	2	2
33	110-00471	Cylinder 5 sections 72" .....	1	1
34	110-00441	Left tandem frame .....	1	1
35	130-23491	Washer .....	1	1
37	190-04451	Hose 3/8" x 240" lg + 2 fittings 8U108 .....	1	-
37	190-03831	Hose 3/8" x 258" lg + 2 fittings 8U108 .....	-	1
38	120-03181	Platform .....	1	-
38	120-03201	Platform .....	-	1
39	Std.	Bolt 7/16" NC x 4 1/2" lg + nylon locknut .....	8	8
40	Std.	Bolt 7/16" NC x 4" lg + nylon locknut .....	6	6
41	Std.	Spring B-616 .....	2	2
42	51436	Clevis pin 1/2" x 1 37/64" lg .....	1	1
43	51435	Yoke 1/2"-20 NF .....	1	1
44	110-17431	Rod 1/2" for lock .....	1	-
44	110-14971	Rod 1/2" for lock .....	-	1



## **DUMPING BOX ON TANDEM P-51624 & P-51824**

REF.	PART #	DESCRIPTION	QTY	
			P-51624	P-51824
45	110-08891	Washer .....	1	1
46	110-08911	Lock assembly pivot .....	1	1
47	150-01811	Clevis pin 3/4" x 3 1/4" lg .....	1	1
48	Std.	Bolt 3/4" NC x 5 1/2" lg + nylon locknut .....	1	1
49	Std.	Nut 1/2"-20NF .....	2	2
50	110-08901	Spring holder .....	1	1
51	10216	Spring 7/16" x 1 3/4" d.i. x 2 5/8" d.e. x 7 1/2" lg .....	1	1
52	Std.	Bolt 5/16" NC x 1 1/2" lg + nylon locknut .....	2	2
53	Std.	Bolt 3/4" NC x 5" lg + nylon locknut .....	2	2
54	130-09981	Hook .....	2	2
55	Std.	Bolt 1/2" NC x 2" lg + nylon locknut .....	2	2
56	120-03851	Rear panel (with grain door) .....	1	1
57	110-17801	Rear stack .....	2	2
58	160-08541	Central stack .....	2	2
59	160-08551	Front stack .....	2	2
60	Std.	Fitting 3/8" -90 degrees swivel .....		

\* = not sold separately



# DUMPING BOX P-1648 & P-1848

170-02751

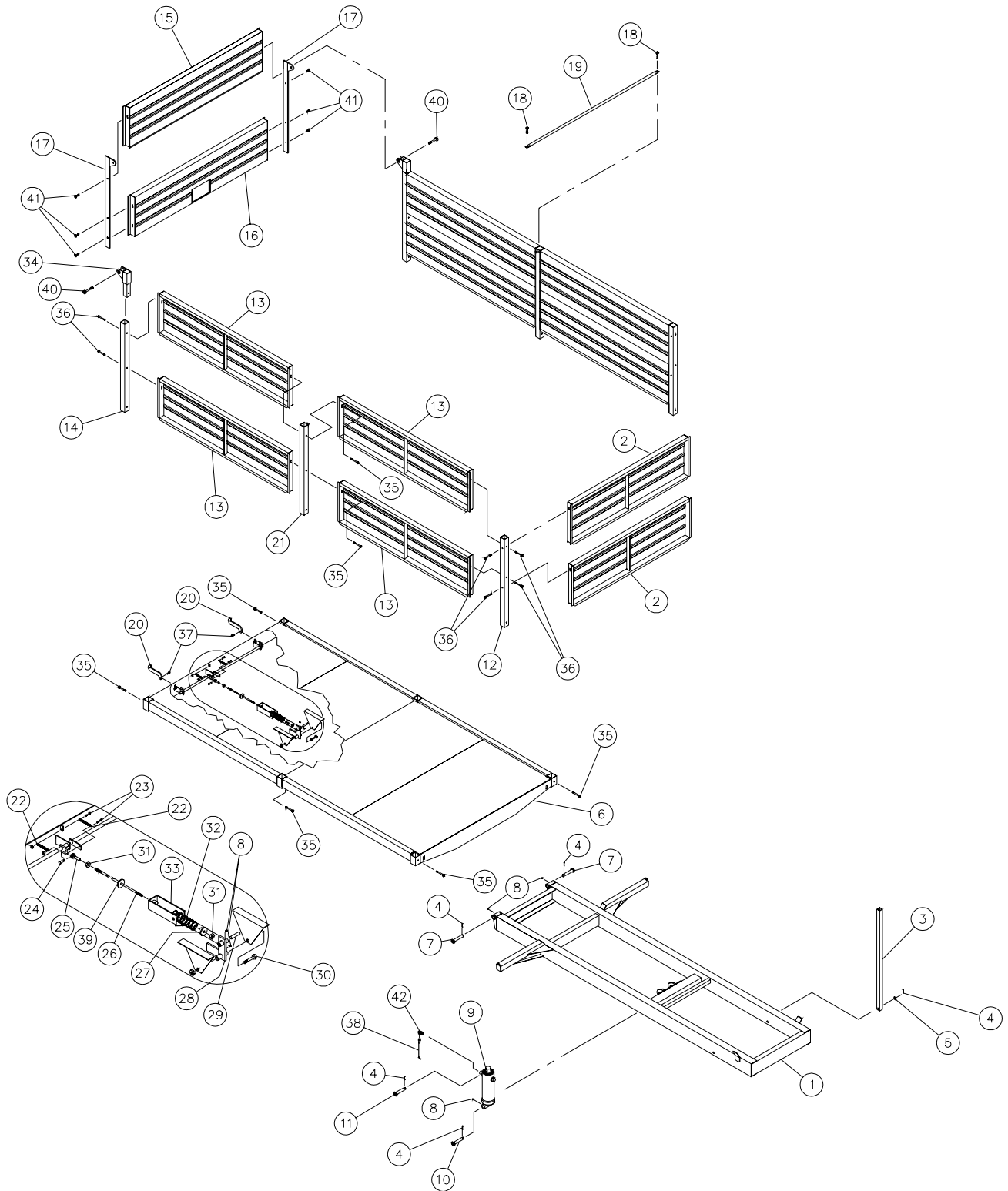

8

# DUMPING BOX P-1648 & P-1848

REF.	PART #	DESCRIPTION	QTY	
			P-1648	P-1848
1	120-03091	Frame .....	1	-
1	120-03101	Frame .....	-	1
2	110-17331	Front panel .....	2	2
3	160-08181	Safetyprop .....	1	1
4	Std.	Cotter pin 1/4" x 2" lg .....	5	5
5	Std.	Flat washer 3/4" .....	1	1
6	120-03071	Platform .....	1	-
6	120-03081	Platform .....	-	1
7	110-17421	Clevis pin 1 1/4" x 7" lg .....	2	2
8	Std.	Grease fitting 1/4" -28 droit .....	8	8
9	Std.	Cylinder 5 sections 72" .....	1	1
10	110-00401	Clevis pin for cylinder (at the bottom) 1 1/2" dia. x 10 1/4" lg .....	1	1
11	110-00421	Clevis pin for cylinder (at the top) 1 1/4" dia. x 9 1/8" lg .....	1	1
12	160-08171	Frontstack .....	2	2
13	110-17341	Side panel .....	8	-
13	110-14901	Side panel .....	-	8
14	160-08201	Rearstack .....	2	2
15	120-03861	Rear panel (haut) .....	1	1
16	120-03851	Rear panel with grain door (bas) .....	1	1
17	110-17441	Rear panel support .....	2	2
18	Std.	Bolt 7/16" NC x 1 1/4" lg + nylon locknut & flat washer .....	2	2
19	160-08161	Crossbar .....	1	1
20	130-09981	Hook .....	2	2
21	110-17381	Centralstack .....	2	2
22	Std.	Spring B-616 .....	2	2
23	Std.	Bolt 5/16" NC x 1 1/2" lg + nylon locknut .....	2	2
24	51436	Clevis pin 1/2" x 1 37/64" lg .....	1	1
25	51435	Yoke 1/2" -20NF .....	1	1
26	110-17431	Rod 1/2" for lock .....	1	-
26	110-14971	Rod 1/2" for lock .....	-	1
27	110-08891	Washer .....	1	1
28	110-08911	Lock assembly pivot .....	1	1
29	150-01811	Clevis pin 3/4" x 3" 1/4 lg .....	1	1
30	Std.	Bolt 3/4" NC x 5 1/2" lg + nylon locknut .....	1	1
31	Std.	Nut 1/2"-20NF .....	2	2
32	10216	Spring 7/16" x 1 3/4" i.d. x 2 5/8" o.d. x 7 1/2" lg .....	1	1
33	110-08901	Spring holder .....	1	1
34	110-17451	Rear stack (haut) .....	2	2
35	Std.	Bolt 7/16" NC x 4 1/2" lg + nylon locknut .....	10	10
36	Std.	Bolt 7/16" NC x 4" lg + nylon locknut .....	12	12
37	Std.	Bolt 1/2" NC x 2" lg + nylon locknut .....	2	2
38	190-04451	Hose 3/8" x 240" lg + 2 fittings 6U108 .....	1	-
38	190-03831	Hose 3/8" x 258" lg + 2 fittings 6U108 .....	-	1
39	130-23491	Washer .....	1	1
40	Std.	Bolt 3/4" NC x 5" lg + nylon locknut .....	2	2
41	Std.	Plow bolt 7/16" NC x 1 1/2" lg + nylon locknut .....	6	6
42	Std.	Fitting 3/8" -90degrees swivel .....	1	1



# DUMPING BOX ON TANDEM P-51648 & P-51848

170-02761

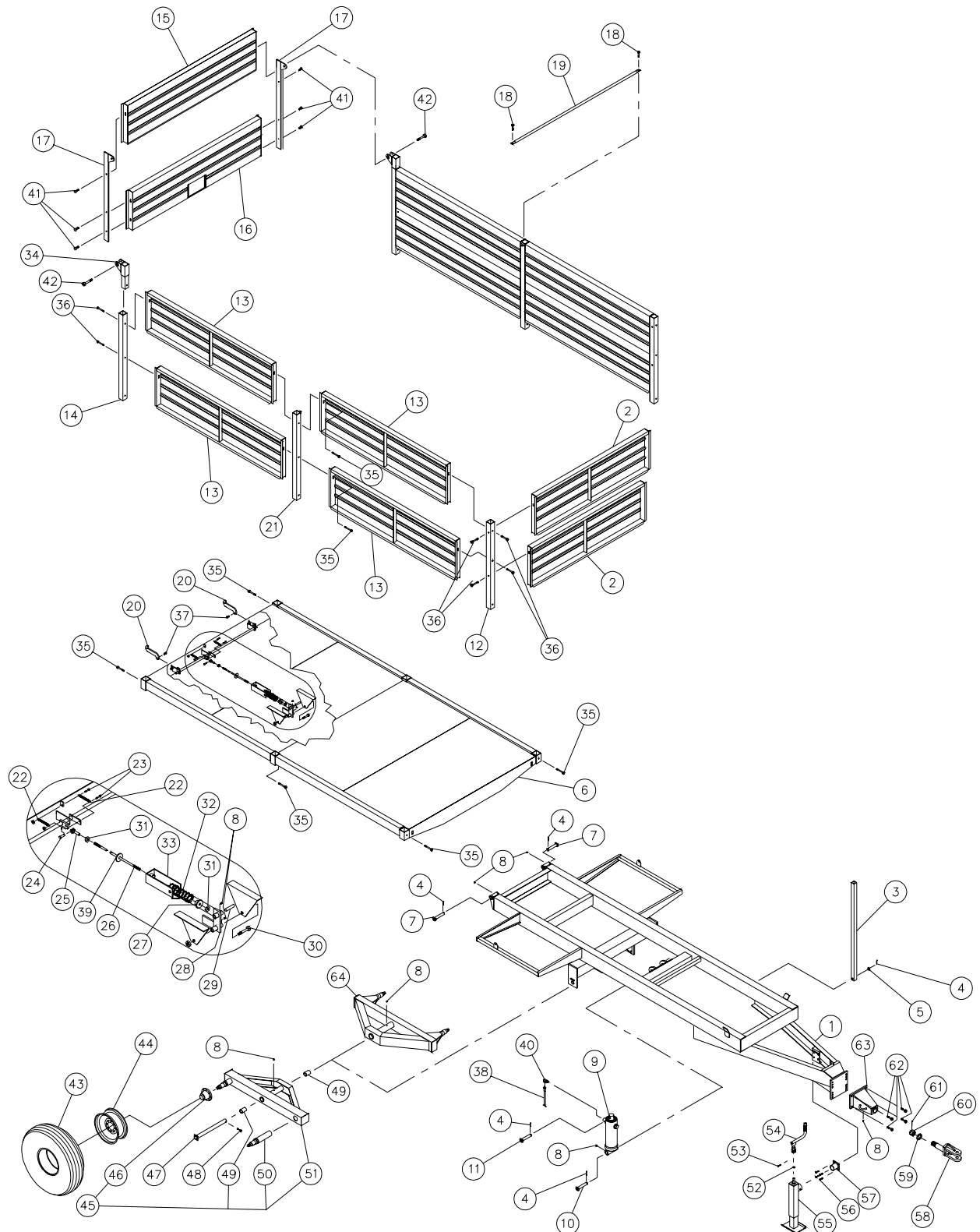

8

# DUMPING BOX ON TANDEM P-51648 & P-51848

REF.	PART #	DESCRIPTION	QTY	
			P-51648	P-51848
1	120-03171	Frame .....	1	-
1	120-03191	Frame .....	-	1
2	110-17331	Front panel .....	2	2
3	160-08181	Safety prop .....	1	1
4	Std.	Cotter pin 1/4" x 2" lg .....	5	5
5	Std.	Flat washer 3/4" .....	1	1
6	120-03181	Platform .....	1	-
6	120-03201	Platform .....	-	1
7	110-17421	Clevis pin 1 1/4" dia. x 7" lg .....	2	2
8	Std.	Grease fitting 1/4" -28 droit .....	8	8
9	110-00471	Cylinder 5 sections 72" .....	1	1
10	110-00401	Clevis pin for cylinder (at the bottom) 1 1/2" dia. x 10 1/4" .....	1	1
11	110-00421	Clevis pin for cylinder (at the top) 1 1/4" dia. x 9 1/8" .....	1	1
12	160-08171	Frontstack .....	2	2
13	110-17341	Side panel .....	8	-
13	110-14901	Side panel .....	-	8
14	160-08201	Rearstack .....	2	2
15	120-03861	Rear panel (haut) .....	1	1
16	120-03851	Rear panel with grain door (bas) .....	1	1
17	110-17441	Rear panel support .....	2	2
18	Std.	Bolt 7/16" NC x 1 1/4" lg + nylon locknut & flat washer .....	2	2
19	160-08161	Crossbar .....	1	1
20	130-09981	Hook .....	2	2
21	110-17381	Centralstack .....	2	2
22	Std.	Spring B-616 .....	2	2
23	Std.	Bolt 5/16" NC x 1 1/2" lg + nylon locknut .....	2	2
24	51436	Clevis pin 1/2" x 1 37/64" lg .....	1	1
25	51435	Yoke 1/2" -20NF .....	1	1
26	110-17431	Rod 1/2" for lock .....	1	-
26	110-14971	Rod 1/2" for lock .....	-	1
27	110-08891	Washer .....	1	1
28	110-08911	Lock assembly pivot .....	1	1
29	150-01811	Clevis pin 3/4" x 3" 1/4 lg .....	1	1
30	Std.	Bolt 3/4" NC x 5 1/2" lg + nylon locknut .....	1	1
31	Std.	Nut 1/2" -20NF .....	2	2
32	10216	Spring 7/16" x 1 3/4" i.d. x 2 5/8" o.d. x 7 1/2" lg .....	1	1
33	110-08901	Spring holder .....	1	1
34	110-17451	Rear stack (haut) .....	2	2
35	Std.	Bolt 7/16" NC x 4 1/2" lg + nylon locknut .....	10	10
36	Std.	Bolt 7/16" NC x 4" lg + nylon locknut .....	12	12
37	Std.	Bolt 1/2" NC x 2" lg + nylon locknut .....	2	2
38	190-04451	Hose 3/8" x 240" lg + 2 fittings 6U108 .....	1	-
38	190-03831	Hose 3/8" x 258" lg + 2 fittings 6U108 .....	-	1
39	130-23491	Washer .....	1	1
40	Std.	Fitting 3/8" -90 degrees swivel .....	1	1
41	Std.	Plow bolt 7/16" NC x 1 1/2" lg + nylon locknut .....	6	6
42	Std.	Bolt 3/4" NC x 5" lg + nylon locknut .....	2	2
43	PN-165161	Tire 16.5 x 16.1-10 plys .....	4	4



# DUMPING BOX ON TANDEM P-51648 & P-51848

REF.	PART #	DESCRIPTION	QTY	
			P-51648	P-51848
44	R-161148	Rim 16.1 x 14-8 bolts .....	4	4
45	110-00444	Right tandem assembly .....	1	1
46	36132	Hub H-8001 assembly .....	4	4
47	110-00501	Clevis 1 3/4" dia. x 21 5/8" lg .....	2	2
48	Std.	Bolt 1/2" NC x 3" lg + nylon locknut .....	2	2
49	160-00661	Bushing 1 3/4" i.d. x 2" o.d. x 3" lg .....	4	4
50	150-00211	Axle (welded) .....	4	4
51	110-00443	Right tandem frame .....	1	1
51	N.I.	Left tandem assembly .....	1	1
52	Std.	Ring 1" .....	1	1
53	Std.	Bolt 1/4" NC x 1" lg + nylon locknut .....	1	1
54	190-01672	Hand crank .....	1*	1*
55	190-01671	Jack 8000 lbs (including #52, #53, #54) .....	1	1
56	Std.	Bolt 7/16" NC x 1 1/4" lg + nylon locknut .....	4	4
57	110-06411	Jack mounting plate .....	1	1
58	110-00491	Swivel hitch .....	1	1
59	130-21111	Flat washer 1 13/16" d.i. x 3" d.e. ....	1	1
60	Std.	Castle nut 1 3/4"-5 NC .....	1	1
61	Std.	Cotter pin 1/4" x 3 1/2" lg .....	1	1
62	Std.	Bolt 3/4" NC x 3" lg + nylon locknut .....	4	4
63	120-00141	Hitchassy. ....	1	1
64	110-00441	Left tandem frame .....	1	1

\* = not sold separately



# DUMPING BOX P-1672 & P-1872

170-02711

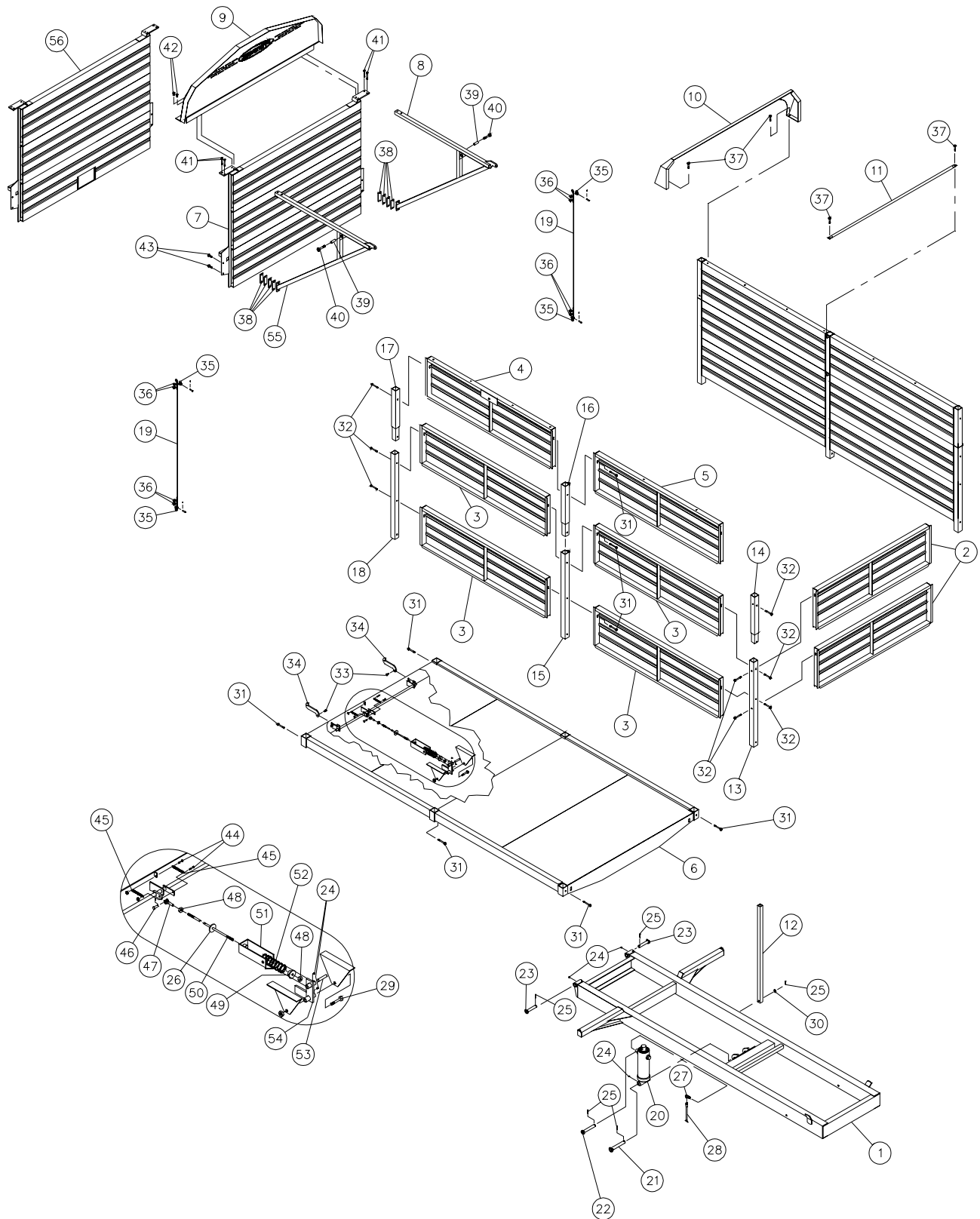

8



# DUMPING BOX P-1672 & P-1872

REF.	PART #	DESCRIPTION	QTY	
			P-1672	P-1872
1	120-03091	Frame .....	1	-
1	120-03101	Frame .....	-	1
2	110-17331	Front panel .....	2	2
3	110-17341	Side panel .....	8	-
3	110-14901	Side panel .....	-	8
4	110-17351	Side panel (top rear) .....	2	-
4	110-14911	Side panel (top rear) .....	-	2
5	110-17361	Side panel (top front) .....	2	-
5	110-14891	Side panel (top front) .....	-	2
6	120-03071	Platform .....	1	-
6	120-03081	Platform .....	-	1
7	120-03821	Rear panel .....	1	1
8	120-03831	Left rear panel pivot .....	1	1
9	110-17231	Perforated rear baffle .....	1	1
10	110-17221	Roof support .....	1	1
11	160-08161	Crossbar .....	1	1
12	160-08181	Safety prop .....	1	1
13	160-08171	Front stack .....	2	2
14	110-17371	Front stack (top) .....	2	2
15	110-17381	Central stack .....	2	2
16	110-17391	Central stack (top) .....	2	2
17	110-17401	Rear stack (top) .....	2	2
18	160-08201	Rear stack .....	2	2
19	190-04391	Cable 1/4" x 97" lg .....	2	2
20	Std.	Cylinder 5 sections 72" .....	1	1
21	110-00401	Clevis pin for cylinder (at the bottom) 1 1/2" dia. x 10 1/4" lg .....	1	1
22	110-00421	Clevis pin for cylinder (at the top) 1 1/4" dia. x 9 1/8" lg .....	1	1
23	110-17421	Clevis pin 1 1/4" dia. x 7" lg .....	2	2
24	Std.	Grease fitting 1/4"-28 straight .....	5	5
25	Std.	Cotter pin 1/4" x 2" lg .....	5	5
26	130-23491	Washer .....	1	1
27	Std.	Fitting 3/8" - 90 degrees swivel .....	1	1
28	190-04451	Hose 3/8" x 240" lg + 2 fittings 8U108 .....	1	-
28	190-03831	Hose 3/8" x 258" lg + 2 fittings 8U108 .....	-	1
29	Std.	Bolt 3/4" NC x 5 1/2" lg + nylon locknut .....	1	1
30	Std.	Flat washer 3/4" .....	1	1
31	Std.	Bolt 7/16" NC x 4 1/2" lg + nylon locknut .....	12	12
32	Std.	Bolt 7/16" NC x 4" lg + nylon locknut .....	16	16
33	Std.	Bolt 1/2" NC x 2" lg + nylon locknut .....	2	2
34	130-09981	Hook .....	2	2
35	Std.	Shackle 3/8" + clevis & cotter pin .....	4	4
36	Std.	Wire clip 1/4" .....	8	8
37	Std.	Bolt 7/16" NC x 1 1/4" lg + nylon locknut & flat washer .....	4	4
38	130-21901	Spacer for rear panel pivot .....	8	8
39	150-03581	Bushing 1" o.d. x 3/4" i.d. x 2 3/4" lg .....	2	2
40	Std.	Bolt 3/4" NC x 4" lg + lock washer .....	2	2
41	Std.	Bolt 7/16" NC x 3 1/2" lg + nylon locknut & flat washer .....	4	4
42	Std.	Bolt 3/8" NC x 1" lg + nylon locknut .....	4	4



## DUMPING BOX P-1672 & P-1872

REF.	PART #	DESCRIPTION	QTY	
			P-1672	P-1872
43	Std.	Bolt 1/2" NC x 1 1/2" lg + nylon locknut .....	4	4
44	Std.	Bolt 5/16" NC x 1 1/2" lg + nylon locknut .....	2	2
45	Std.	Spring B-616 .....	2	2
46	51436	Clevis pin 1/2" x 1 37/64" lg .....	1	1
47	51435	Yoke 1/2"-20NF .....	1	1
48	Std.	Nut 1/2"-20NF .....	2	2
49	110-08891	Washer .....	1	1
50	110-17431	Rod 1/2" for lock .....	1	-
50	110-14971	Rod 1/2" for lock .....	-	1
51	110-08901	Spring holder .....	1	1
52	10216	Spring 7/16" x 1 3/4" i.d. x 2 5/8" d.o. x 7 1/2" lg .....	1	1
53	150-01811	Clevis pin 3/4" dia. x 3 1/4" lg .....	1	1
54	110-08911	Lock assembly pivot .....	1	1
55	120-03832	Right rear panel pivot .....	1	1
56	120-03841	Grain door .....	opt.	opt.

# DUMPING BOX ON TANDEM P-51672 & P-51872

170-02741

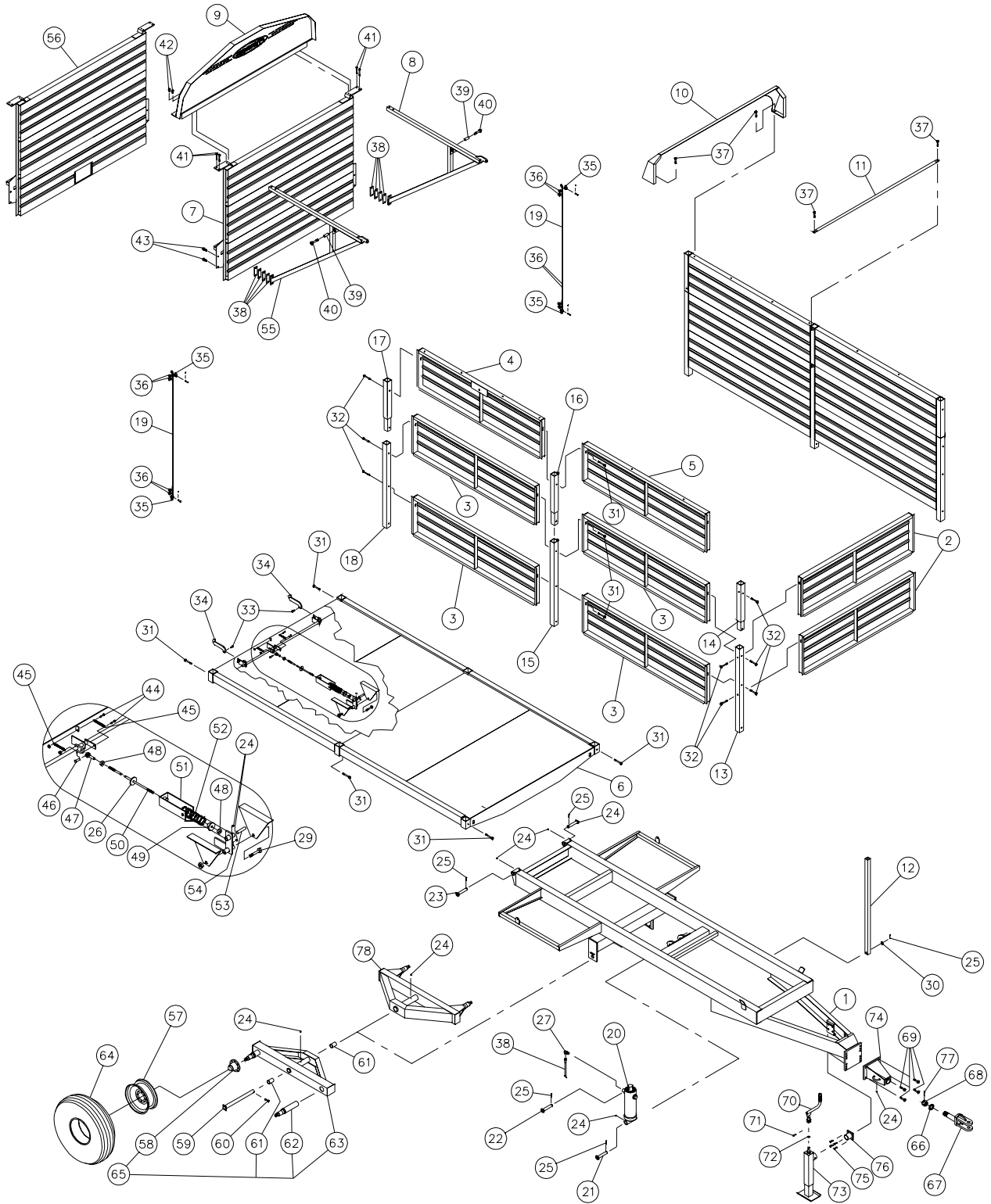

8

# DUMPING BOX ON TANDEM P-51672 & P-51872

REF.	PART #	DESCRIPTION	QTY	
			P-51624	P-51824
1	120-03171	Frame .....	1	-
1	120-03191	Frame .....	-	1
2	110-17331	Front panel .....	2	2
3	110-17341	Side panel .....	8	-
3	110-14901	Side panel .....	-	8
4	110-17351	Side panel (top rear) .....	2	-
4	110-14911	Side panel (top rear) .....	-	2
5	110-17361	Side panel (top front) .....	2	-
5	110-14891	Side panel (top front) .....	-	2
6	120-03181	Platform .....	1	-
6	120-03201	Platform .....	-	1
7	120-03821	Rear panel .....	1	1
8	120-03831	Left rear panel pivot .....	1	1
9	110-17231	Perforated rear baffle .....	1	1
10	110-17221	Roof support .....	1	1
11	160-08161	Crossbar .....	1	1
12	160-08181	Safetyprop .....	1	1
13	160-08171	Frontstack .....	2	2
14	110-17371	Front stack (top) .....	2	2
15	110-17381	Centralstack .....	2	2
16	110-17391	Central stack (top) .....	2	2
17	110-17401	Rear stack (top) .....	2	2
18	160-08201	Rear stack .....	2	2
19	190-04391	Cable 1/4" .....	2	2
20	110-00471	Cylinder 5 sections 72" .....	1	1
21	110-00401	Clevis pin for cylinder (at the bottom) 1 1/2" dia. x 10 1/4" lg .....	1	1
22	110-00421	Clevis pin for cylinder (at the top) 1 1/2" dia. x 9 1/8" lg .....	1	1
23	110-17421	Clevis pin 1 1/4" x 7" lg .....	2	2
24	Std.	Grease fitting 1/4"-28 straight .....	8	8
25	Std.	Cotter pin 1/4" x 2" lg .....	5	5
26	130-23491	Washer .....	1	1
27	Std.	Fitting 3/8" -90degrees swivel .....	1	1
28	190-04451	Hose 3/8" x 240" lg + 2 fittings 8U108 .....	1	-
28	190-03831	Hose 3/8" x 258" lg + 2 fittings 8U108 .....	-	1
29	Std.	Bolt 3/4" NC x 5 1/2" lg + nylon locknut .....	1	1
30	Std.	Flat washer 3/4" .....	1	1
31	Std.	Bolt 7/16" NC x 4 1/2" lg + nylon locknut .....	12	12
32	Std.	Bolt 7/16" NC x 4" lg + nylon locknut .....	16	16
33	Std.	Bolt 1/2" NC x 2" lg + nylon locknut .....	2	2
34	130-09981	Hook .....	2	2
35	Std.	Shackle 3/8" + clevis & cotter pin .....	4	4
36	Std.	Wire clip 1/4" .....	8	8
37	Std.	Bolt 7/16" NC x 1 1/4" lg + nylon locknut & flat washer .....	4	4
38	130-21901	Spacer for rear panel pivot .....	8	8
39	150-03581	Bushing 1" o.d. x 0.765 i.d. x 2 3/4" lg .....	2	2
40	Std.	Bolt 3/4" NC x 4" lg + lock washer .....	2	2
41	Std.	Bolt 7/16" NC x 3 1/2" lg + nylon locknut & flat washer .....	4	4
42	Std.	Bolt 3/8" NC x 1" lg + flat washer .....	4	4

8

# DUMPING BOX ON TANDEM P-51672 & P-51872

REF.	PART #	DESCRIPTION	QTY	
			P-51624	P-51824
43	Std.	Bolt 1/2" NC x 1 1/2" lg + nylon locknut .....	4	4
44	Std.	Bolt 5/16" NC x 1 1/2" lg + nylon locknut .....	2	2
45	Std.	Spring B-616 .....	2	2
46	51436	Clevis pin 1/2" x 1 37/64" lg .....	1	1
47	51435	Yoke 1/2"-20NF .....	1	1
48	Std.	Nut 1/2"-20NF .....	2	2
49	110-08891	Washer .....	1	1
50	110-17431	Rod 1/2" for lock .....	1	-
50	110-14971	Rod 1/2" for lock .....	-	1
51	110-08901	Spring holder .....	1	1
52	10216	Spring 7/16" x 1 3/4" i.d. x 2 5/8" o.d. x 7 1/2" lg .....	1	1
53	150-01811	Clevis pin 3/4" dia. x 3 1/4" lg .....	1	1
54	110-08911	Lock assembly pivot .....	1	1
55	120-03832	Right rear panel pivot .....	1	1
56	120-03841	Grain door .....	1	1
57	R-161148	Rim 16.1 x 14-8 bolts .....	4	4
58	36132	HybH-8001 assembly .....	4	4
59	110-00501	Clevis 1 3/4" dia. x 21 5/8" lg .....	2	2
60	Std.	Bolt 1/2" NC x 3" lg + nylon locknut .....	2	2
61	160-00661	Bushing 1 3/4" d.i. x 2" d.e. x 3" lg .....	4	4
62	150-00211	Axle (welded) .....	4	4
63	110-00443	Right tandem frame .....	1	1
64	PN-165161	Tire 16.5 x 16.1 - 10 plys .....	4	4
65	110-00444	Right tandem assembly .....	1	1
66	130-21111	Flat washer 1 13/16" i.d. x 3" o.d. ....	1	1
67	110-00491	Swivel hitch .....	1	1
68	Std.	Castle nut 1 3/4" -5 NC .....	1	1
69	Std.	Bolt 3/4" NC x 3" lg + nylon locknut .....	4	4
70	190-01672	Hand crank .....	1*	1*
71	Std.	Bolt 1/4" NC x 1" lg + nylon locknut .....	1	1
72	Std.	Ring 1" .....	1	1
73	190-01671	Jack 8000 lbs (including #70, #71 et #72) .....	1	1
74	120-00141	Hitchassy. ....	1	1
75	Std.	Bolt 7/16" NC x 1 1/4" lg + nylon locknut .....	4	4
76	110-06411	Jack mounting plate .....	1	1
77	Std.	Cotter pin 1/4" x 3 1/2" lg. ....	1	1
78	110-00441	Left tandem frame .....	1	1

\* = not sold separately



# DUMPING BOX ROOF

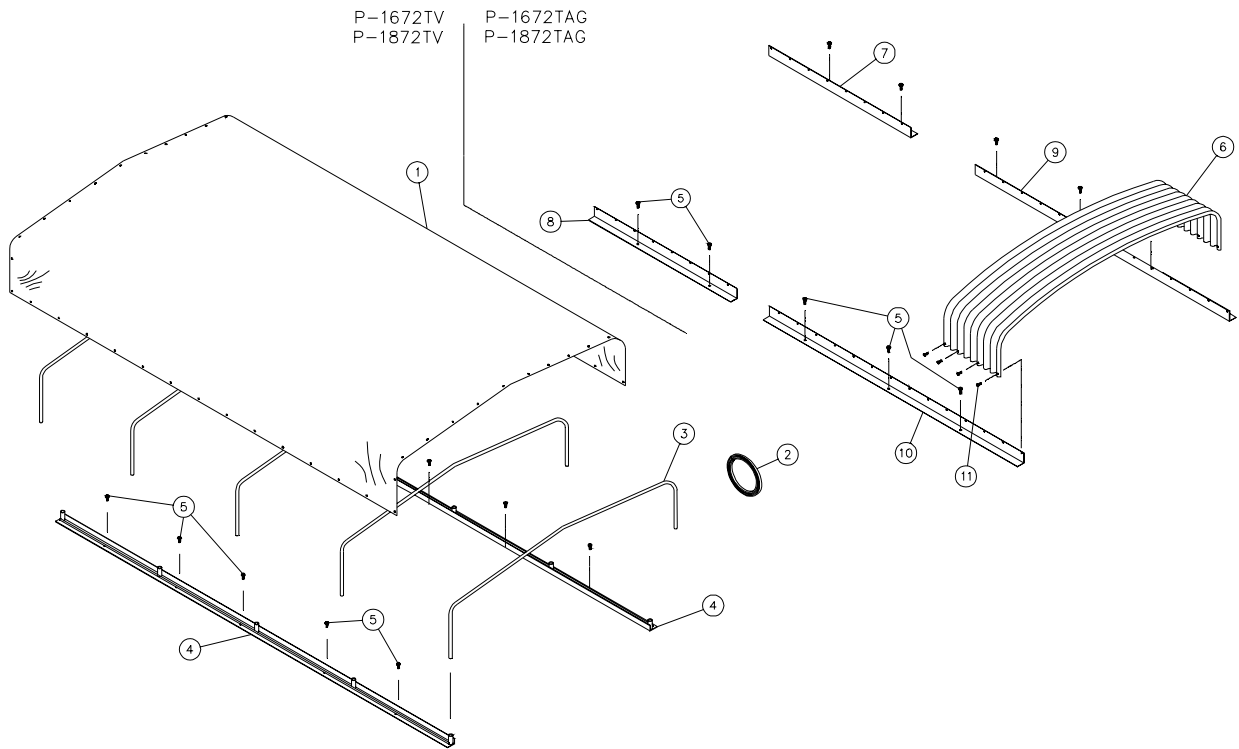

REF.	PART #	DESCRIPTION	QTY			
			P-1672TV	P-1872TV	P-1672TAG	P-1872TAG
1	190-03821	Canvasroof .....	1	-	-	-
1	190-03791	Canvasroof .....	-	1	-	-
2	190-04401	Nylon rope 50' lg .....	1	-	-	-
2	190-04411	Nylon rope 54' lg .....	-	1	-	-
3	160-07091	Roof support for canvas .....	5	6	-	-
4	190-03771	Iron angle for canvas roof .....	2	-	-	-
4	190-03781	Iron angle for canvas roof .....	-	2	-	-
5	Std.	Bolt 7/16" x 1" lg + nylon locknut .....	10	10	10	10
6	130-21891	Galvanized steel roof .....	-	-	7	8
7	130-17541	Iron angle for galvanized steel roof (left rear) .....	-	-	1	-
7	130-17521	Iron angle for galvanized steel roof (left rear) .....	-	-	-	1
8	130-17981	Iron angle for galvanized steel roof (right rear) .....	-	-	1	-
8	130-17522	Iron angle for galvanized steel roof (right rear) .....	-	-	-	1
9	130-17531	Iron angle for galvanized steel roof (left front) .....	-	-	1	-
9	130-17511	Iron angle for galvanized steel roof (left front) .....	-	-	-	1
10	130-17971	Iron angle for galvanized steel roof (right front) .....	-	-	1	-
10	130-17512	Iron angle for galvanized steel roof (right front) .....	-	-	-	1
11	Std.	Bolt 5/16" NC x 1" lg + nylon locknut & flat washer .....	-	-	44	55

8

# TELESCOPIC CYLINDER 110-00471

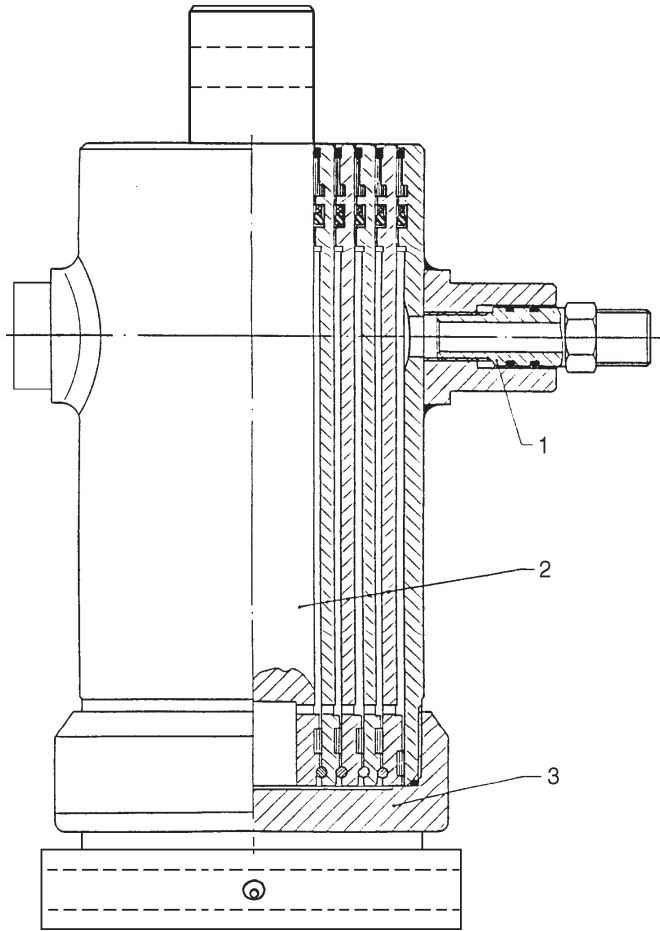

REF.	PART #	DESCRIPTION	QTY
1	51586	Connector .....	1
2	51595	Piston .....	1
3	110-00472	Threaded cylinder base .....	1
NI*	51597	Repair kit for cylinder .....	1
NI*	51589	Seal kit for connector .....	1

\*NI = Not illustrated

8

# HUB H8001 (36132)

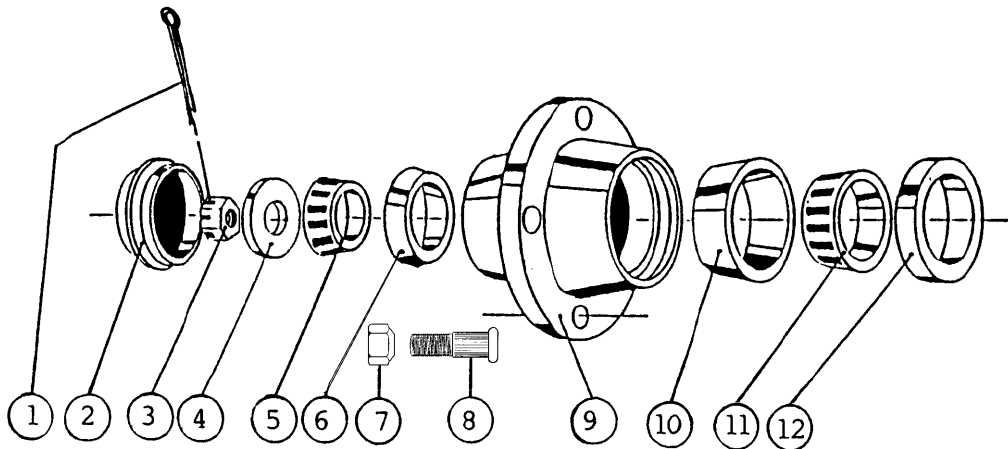







REF.	PART #	DESCRIPTION	QTY
1	Std.	Cotter pin 3/16" x 2 1/2" .....	1
2	36114	Dust cap 3.135" ø .....	1
3	36116	Castle nut 1" - 14 .....	1
4	Std.	Flat washer 1" .....	1
5	36118	Roller bearing Timken: cone no. LM 501349 .....	1
6	36120	Roller bearing Timken: cup no. LM 501310 .....	1
7	36135	Nut 5/8" .....	8
8	36122	Stud 5/8" x 2 1/8" .....	8
9	36123	Hub only H8001 .....	1
10	36125	Roller bearing Timken: cup no. LM 506810 .....	1
11	36127	Roller bearing Timken: cone no. LM 506849 .....	1
12	36129	Oil seal no. CR27361 .....	1







# TORQUE CHART

## TORQUE SPECIFICATION TABLE

Thread UNC and UNF		Grade 2 				Grade 5   				Grade 8*   			
Bolt size		Torque				Torque				Torque			
Inches	mm	Pound feet min.	max.	Newton meters min.	max.	Pound feet min.	max.	Newton meters min.	max.	Pound feet min.	max.	Newton meters min.	max.
1/4	6.35	5	6	6.8	8.13	9	11	12.2	14.9	12	15	16.3	30.3
5/16	7.94	10	12	13.6	16.3	17	20.5	23.1	27.8	24	29	32.5	39.3
3/8	9.53	20	23	27.1	31.2	35	42	47.5	57.0	45	54	61.0	73.2
7/16	11.11	30	35	40.7	47.4	54	64	73.2	86.8	70	84	94.9	113.9
1/2	12.70	45	52	61.0	70.5	80	96	108.5	130.2	110	132	149.2	179.0
9/16	14.29	65	75	88.1	101.6	110	132	149.2	179.0	160	192	217.0	260.4
5/8	15.88	95	105	128.7	142.3	150	180	203.4	244.1	220	264	298.3	358.0
3/4	19.05	150	185	203.3	250.7	270	324	366.1	439.3	380	456	515.3	618.3
7/8	22.23	160	200	216.8	271.0	400	480	542.4	650.9	600	720	813.6	976.3
1	25.40	250	300	338.8	406.5	580	696	786.5	943.8	900	1080	1220.4	1464.5
1 1/8	25.58	-	-	-	-	800	880	1084.8	1193.3	1280	1440	1735.7	1952.6
1 1/4	31.75	-	-	-	-	1120	1240	1518.7	1681.4	1820	2000	2467.9	2712.0
1 3/8	34.93	-	-	-	-	1460	1680	1979.8	2278.1	2380	2720	3227.3	3688.3
1 1/2	38.10	-	-	-	-	1940	2200	2630.6	2983.2	3160	3560	4285.0	4827.4

\* Thick nuts must be used with grade 8 bolts.

Size of screw	Thread	Pitch (mm)	Grade 4T  				Grade 7T 				Grade 8T  			
			Torque				Torque				Torque			
			Pound feet min.	max.	Newton meters min.	max.	Pound feet min.	max.	Newton meters min.	max.	Pound feet min.	max.	Newton meters min.	max.
M6	UNC	1.00	3.6	5.8	4.9	7.9	5.8	9.4	7.9	12.7	7.2	10	9.8	13.6
M8	UNC	1.25	7.2	14	9.8	19	17	22	23	29.8	20	26	27.1	35.2
M10	UNC	1.5	20	25	27.1	33.9	34	40	46.1	54.2	38	46	51.5	62.3
M12	UNC	1.75	28	34	37.9	46.1	51	59	69.1	79.9	57	66	77.2	89.4
M14	UNC	2.0	49	56	66.4	75.9	81	93	109.8	126	96	109	130.1	147.7
M16	UNC	2.0	67	77	90.8	104.3	116	130	157.2	176.2	129	145	174.8	196.5
M18	UNC	2.0	88	100	119.2	136	150	168	203.3	227.6	175	194	237.1	262.9
M20	UNC	2.5	108	130	146.3	176.2	186	205	252	277.8	213	249	288.6	337.4
M8	UNF	1.0	12	17	16.3	23	19	27	25.7	36.6	22	31	29.8	42
M10	UNF	1.25	20	29	27.1	39.3	35	47	47.4	63.7	40	52	54.2	70.5
M12	UNF	1.25	31	41	42	55.6	56	68	75.9	92.1	62	75	84	101.6
M14	UNF	1.5	52	64	70.5	86.7	90	106	122	143.6	107	124	145	168
M16	UNF	1.5	69	83	93.5	112.5	120	138	162.6	187	140	158	189.7	214.1
M18	UNF	1.5	100	117	136	158.5	177	199	239.8	269.6	202	231	273.7	313
M20	UNF	1.5	132	150	178.9	203.3	206	242	279.1	327.9	246	289	333.3	391.6

Use the above torques when special torque is not given.

NOTE: These values apply to fasteners as received from supplier, dry, or when lubricated with normal engine oil. They do not apply if extreme pressure lubricants are used.

---

---

## **WARRANTY**

---

PRONOVOST warrants this product to the initial purchaser for the period of one year from the date of purchase against defects in materials and workmanship.

We will replace or repair defective parts free of charge if they are returned to our plant in St-Tite, Quebec, Canada.

Transportation charges are the responsibility of the customer. This warranty is not transferable.

Hydraulic cylinders are covered by the manufacturer of these items.

All PRONOVOST spare parts purchased are covered by a three (3) month warranty.

This warranty becomes void and nul if the equipment is modified, breaks down as the result of an accident, is not operated according to manufacturer's recommendations, damaged by negligence or if maintenance has not been carried out as specified.

Our obligation is limited to the replacement or repair of the defective part. PRONOVOST accepts no responsibility for direct or indirect consequential damages of any kind.



Ce manuel est aussi disponible en français.  
Veuillez téléphoner.



**INNOVATION - EXCELLENCE**

**LES MACHINERIES PRONOVOST INC.**  
260, route 159,  
Saint-Tite, Quebec, Canada, G0X 3H0  
Tel.: (418) 365-7551, Fax: (418) 365-7954  
[www.pronovost.qc.ca](http://www.pronovost.qc.ca)