



**OPERATOR'S / PARTS  
MANUAL**



***Auto-Load Round Bale Handler***  
**Models**

<b>P-6808</b>	<b>P-6812</b>	<b>P-6816</b>
<b>P-6808M</b>	<b>P-6812M</b>	<b>P-6816M</b>

VISIT OUR WEBSITE



[www.pronovost.qc.ca](http://www.pronovost.qc.ca)

Copyright © Les Machineries Pronovost Inc., 2006

All rights reserved.  
Printed in Canada.

---



---

# TABLE OF CONTENTS

---

Section	Item	Page
<b>1</b>	<b>Introduction .....</b>	<b>5</b>
<b>2</b>	<b>Safety .....</b>	<b>6</b>
	General Safety .....	6
	Safety in Operation .....	6
	Safety with Maintenance .....	6
	Safety in Transport .....	6
	Safety in Storage .....	6
<b>3</b>	<b>Decals .....</b>	<b>7</b>
	Safety Decals .....	7
	Maintenance Decals .....	8
<b>4</b>	<b>Start-up .....</b>	<b>9</b>
	Basic Start-up Procedures .....	9
	Adjustments .....	10
	Operation .....	11
<b>5</b>	<b>Maintenance .....</b>	<b>13</b>
<b>6</b>	<b>Storage .....</b>	<b>14</b>
<b>7</b>	<b>Specifications .....</b>	<b>15</b>
<b>8</b>	<b>Parts List .....</b>	<b>16</b>
	Auto-Load Round Bale Handler P-6808 and P-6808M .....	16
	Auto-Load Round Bale Handler P-6812 and P-6812M .....	19
	Auto-Load Round Bale Handler P-6816 and P-6816M .....	22
	Electric system P-6808, P-6812 and P-6816 .....	25
	Electrique cchema "LADDER diagram" .....	27
	Hydraulic system: P-6808 .....	29
	Hydraulic system: P-6808M and third bale row option .....	30
	Hydraulic system: P-6812 .....	32
	Hydraulic system: P-6812M and third bale row option .....	34
	Hydraulic system P-6816 .....	36
	Hydraulic system: P-6816M and third bale row option .....	38
	Hydraulic system for third bale row on P-6808, P-6812 and P-6816 .....	40
	Cylinder 30AT20 .....	41
	Cylinder 35B24 .....	42
	Cylinder 30FT84 .....	43
	Cylinder 30TR12 .....	44
	Cushion valve .....	45
	Telescopic cylinder 110-00471 .....	46
	Hubs H8001 H10000 .....	47
<b>9</b>	<b>Torque Chart .....</b>	<b>48</b>
<b>10</b>	<b>Warranty .....</b>	<b>49</b>



---

---

# INTRODUCTION

---

## CONGRATULATIONS!

Thank you for choosing PRONOVOST. We are confident this equipment will meet your requirements in terms of quality, performance and reliability.

This manual was prepared to assist you in the safe operation of your new Auto-Load Round Bale Handler. It contains important information which will help you achieve excellent returns with your round bale handler for years to come.

Please read this manual completely before operating this equipment and keep it for future reference.

Before using the equipment, you or any other person who will be operating the Round Bale Handler must be familiarized with the safety recommendations. Please read carefully and be sure to understand and follow all recommendations and procedures.

In this manual, the right and left sides of the equipment are identified while standing behind the machine and facing it.

If you require additional information on your Round Bale Handler, please contact your PRONOVOST Dealer.

**NOW** take a moment to enter the model, serial number and the date of purchase of your Auto-Load Round Bale Handler in the space provided.

When ordering parts from your Dealer, please refer to these numbers for a fast and efficient service. Use PRONOVOST replacement parts.

The model and serial numbers are on the nameplate shown on Figure 1.

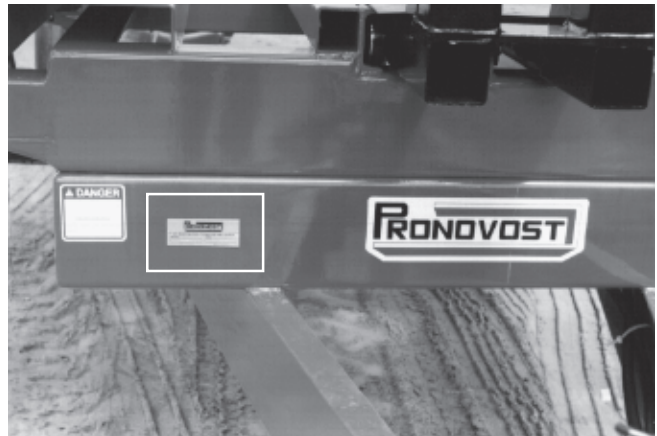

Figure 1

MODEL: \_\_\_\_\_ ✍

SERIAL NO.: \_\_\_\_\_ ✍

DATE OF PURCHASE: \_\_\_\_\_ ✍

---

---

# ***SAFETY***

---

## ***GENERAL SAFETY***

### **WHEN YOU SEE THIS SYMBOL**

**2**



**ATTENTION!**

**BE ALERT  
YOUR SAFETY IS INVOLVED**

This symbol "**SAFETY ALERT**" is used in this manual and on the safety decals on the Round Bale Handler. It warns you of the possibility of danger. Carefully read, understand and follow all safety recommendations before operating the unit.

- 1) Careful operation is the best assurance against accidents. Carefully read this manual and follow all recommendations before operating your Round Bale Handler. It is the owner's responsibility to make sure that anyone who will operate the unit will read this manual before operating the equipment.
- 2) Never let a child nor unauthorized persons operate the machine.
- 3) Do not modify the equipment. Any non authorized modification may affect the efficiency and/or safety of the equipment.
- 4) Never operate the Round Bale Handler with defective parts or if damaged in any way. Have it repaired before operating.
- 5) Make sure all fasteners are in place and properly secured or tightened. Refer to torque chart on page 48.
- 6) Hydraulic fluids under pressure can damage your skin. Do not use your hands to locate a leak. Gloves must be worn.

## ***SAFETY IN OPERATION***

- 1) Be sure there are no obstructions around the equipment and that no one stands near the machine when in operation or unloading.
- 2) Be careful when adjusting equipment with engine running.
- 3) Keep your body, hands, feet, hair and clothing away from moving parts.
- 4) Do not stand nor allow anyone to stand under elevated parts of the machine.
- 5) When not in use, always lock the loading arms with the pin provided. (Figure 10, page 9)

## ***SAFETY WITH MAINTENANCE***

- 1) Perform maintenance according to the recommendations contained in this manual.
- 2) Stop engine and relieve all hydraulic pressures before doing inspection, maintenance or repairs.
- 3) Regularly check hydraulic lines and fittings for leaks. Replace if necessary.
- 4) If you must perform work under the raised platform, **always block it in position in a safe manner.**

## ***SAFETY IN TRANSPORT***

- 1) Check local regulations for the transport of your Round Bale Handler on the road.
- 2) Be alert when pulling the Round Bale Handler on the road. Do not allow anyone to stand on it while in motion.
- 3) Be careful while backing-up.

## ***SAFETY IN STORAGE***

- 1) Lock the loading arms with the pin provided. (Figure 10, page 9)

# DECALS

## SAFETY DECALS

The safety decals are affixed wherever special safety precautions are indicated. Locate them on the machine and read them carefully. If a decal is damaged, lost or illegible, install a new one. Each decal is identified with a letter and part number. The following photos indicate where each one must be installed.



Figure 2  
Decal A

Part no.: A101

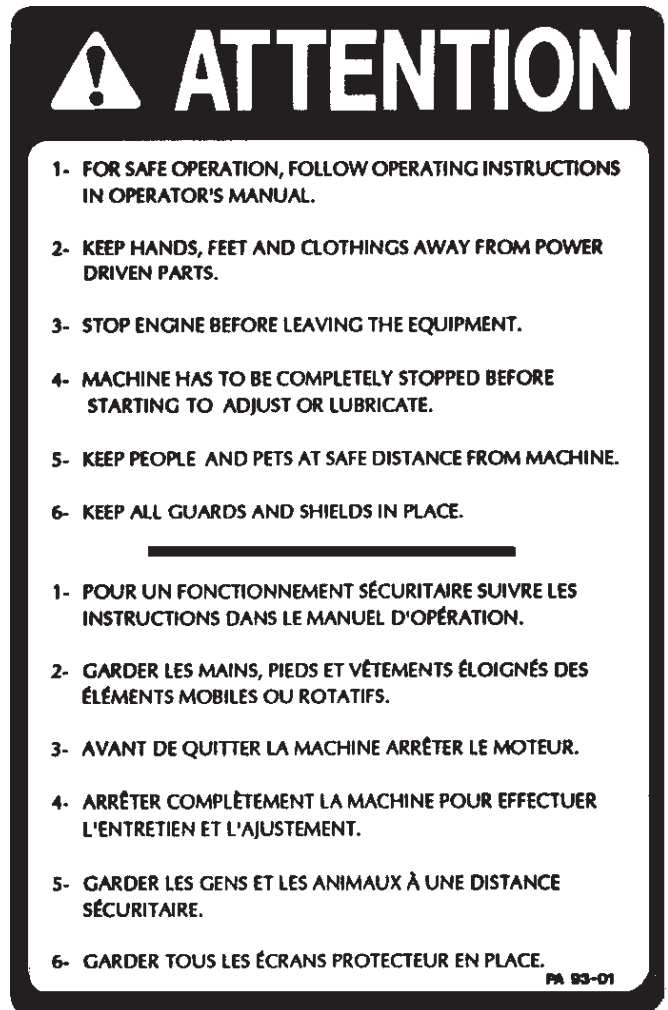

Figure 4  
Decal B

Part no.: A102

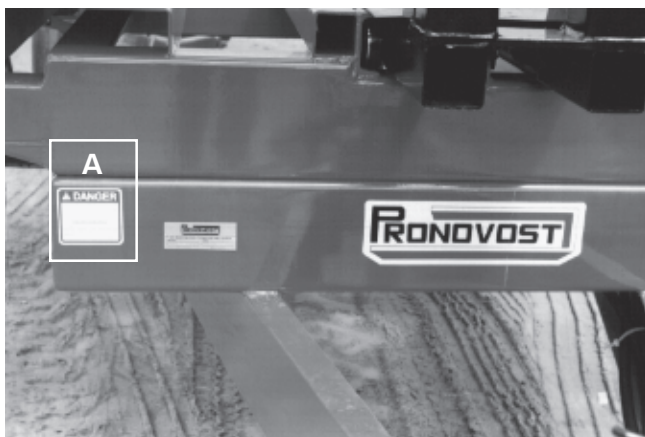

Figure 3

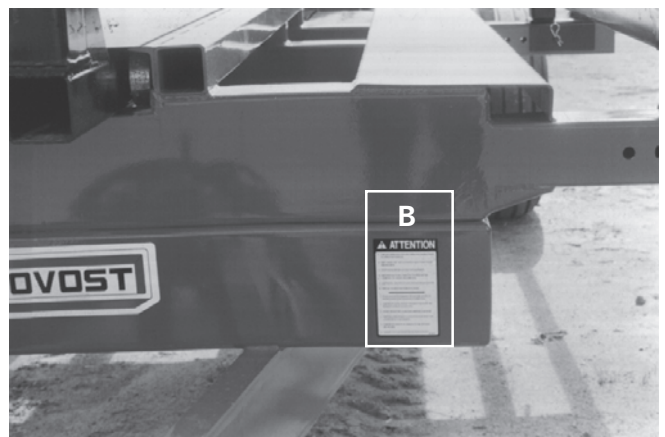

Figure 5

---

---

## DECALS (cont'd)

---



Figure 6  
Decal C

Part no.: A103

3



Figure 7

### MAINTENANCE DECALS

The maintenance decals indicate the points requiring lubrication. Refer to the maintenance section for more details.

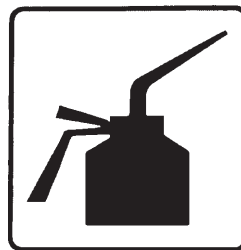

Part no.: A105



Part no.: A106

Figure 8



# START-UP



Figure 9

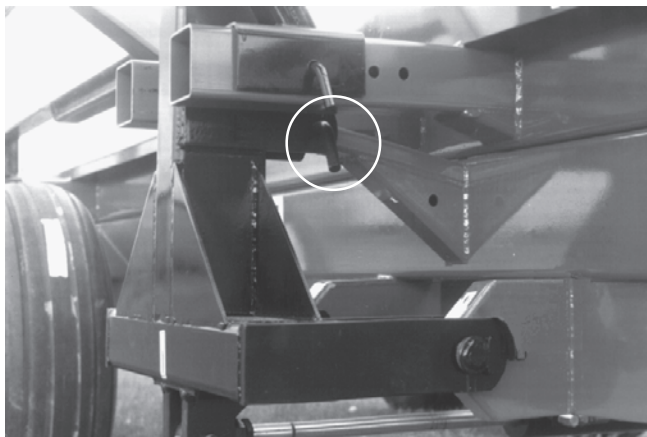

Figure 10

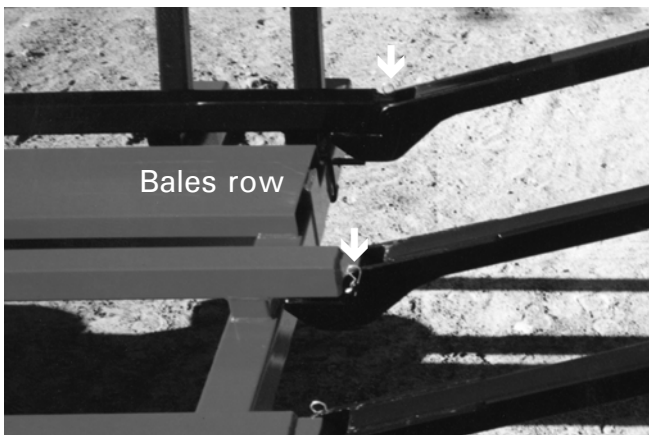

Figure 11

## BASIC START-UP PROCEDURES

- 1) Oil flow recommended 15 to 18 gal. US / min.
- 2) Lubricate all points with a good quality multi use grease.
- 3) Adjust tire pressure according to manufacturer's recommendation.
- 4) Install all hydraulic hoses and fittings compatible with your equipment.

### Models P-6808, P-6812 & P-6816 only.

- 5) If your tractor is equipped with a closed center hydraulic system, the conversion kit P-6890CF must be installed. A plug-in solenoid valve is provided as an option and must be connected to the hydraulic circuit and to the electric circuit. (Figure 9).

### Models P-6812 & P-6816 only.

- 6) A third hydraulic line is required to return the oil directly to the hydraulic reservoir of the tractor.
- 7) Hook up the Round Bale Handler to the tractor and connect the hydraulic hoses as indicated in page 28, 30, 32,34, 36 or 38.

### Models P-6808, P-6812 & P-6816 only.

- 8) Install the control module in a convenient location near the tractor seat, usually on the right hand side.
- 9) Operate all hydraulic functions in order to purge the system. **Do not forget to remove the pin locking the loading arm in the upright position (Figure 10) and assure there is no one within 10 feet of the loading area.**
- 10) Check the oil level in the tractor's hydraulic oil reservoir.
- 11) Install hinged bale slides. Insert the bolts so that the nuts are toward the outer side of the bale row to prevent the bale twine from snagging on the nuts. (Figure 11)
- 12) Although it is possible to transport an additional bale in the loading arm, **its weight must not exceed 1000 lbs.**

4

## START-UP (cont'd)

4

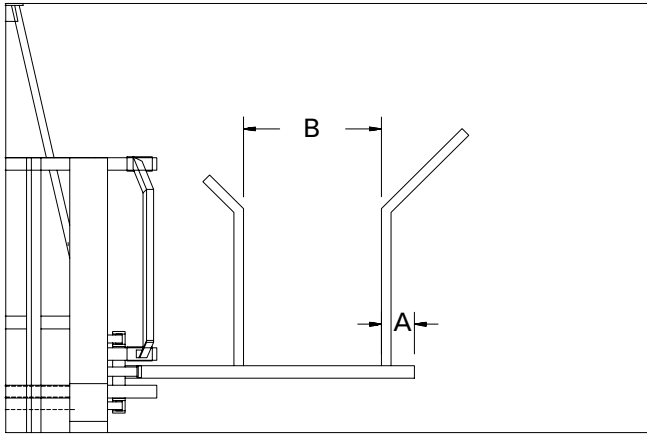

Figure 12

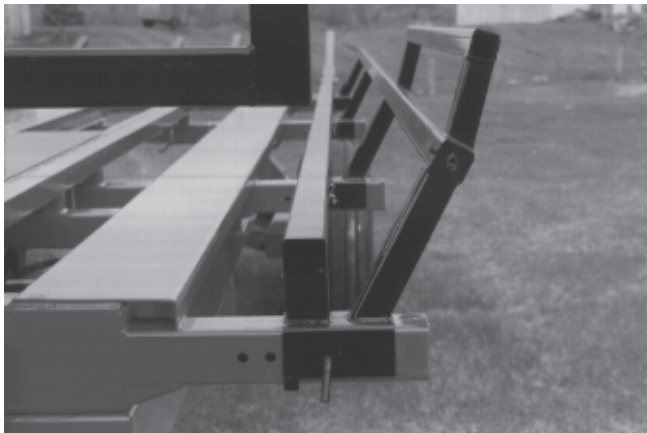

Figure 13



Figure 14

## ADJUSTMENTS

### LOADING ARMS (Patented)

- 1) Adjust the opening and position of the loading arms according to recommendations (Figure 12). Adjust length A to 14" and length B to (Bale diameter less 8" to 10"). The dimensions given are to be used as a guide only since they may vary according to the bale size, weight and degree of softness.

### SIDE RAILS

- 1) Adjust the side rails position according to the bale size and configuration (Figure 13). This adjustment is to prevent the rocking of the bales from side to side during transportation.

### BALE RAM

#### Models P-6808, P-6812 & P-6816 only.

- 1) The length of stroke is factory set for the longest bale dimension (5 1/2') (holes A & B) although the stroke can be shortened to further increase the efficiency of the machine while handling shorter bales (4') (holes B & C) (Figure 14).

### SWIVEL HITCH ASSEMBLY

- 1) Adjust the swivel hitch assembly to keep the machine parallel with the ground. Two sets of bolt holes are provided (Figure 15) to keep the machine level in operation.

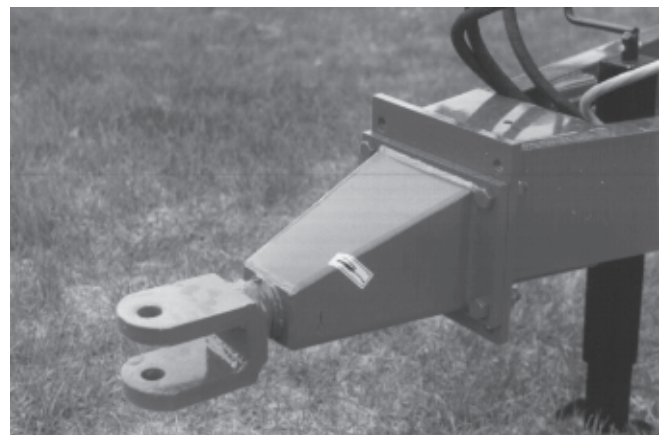

Figure 15

## START-UP (cont'd)

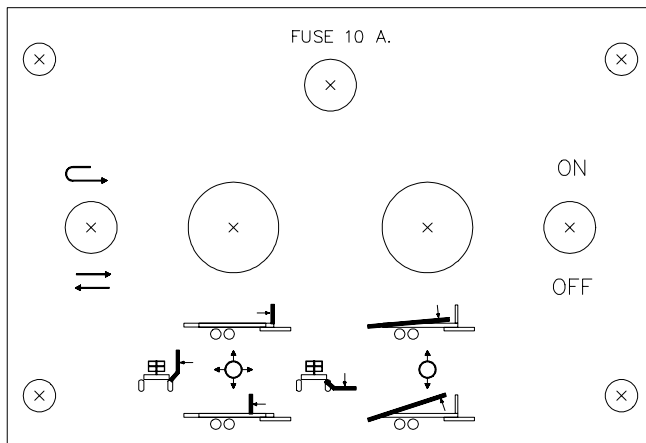

Figure 16

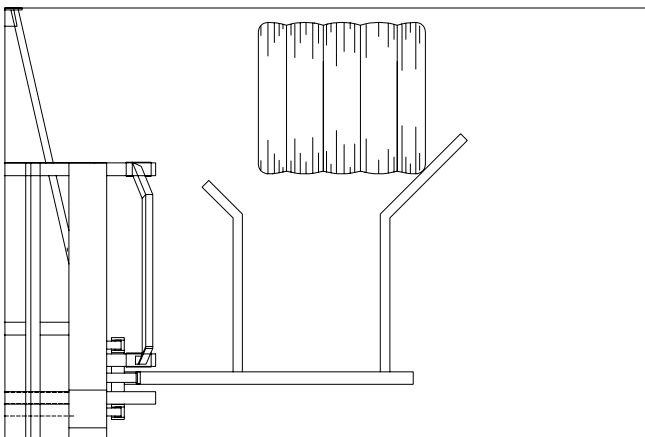

Figure 17

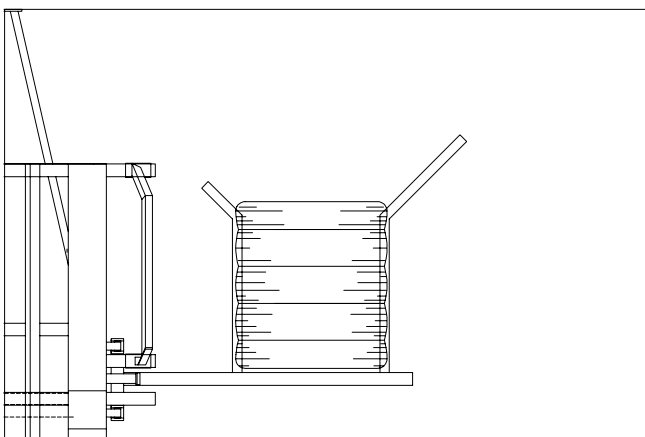

Figure 18

## OPERATION

### Models P-6808, P-6812 & P-6816 only.

- 1) First familiarize yourself with the controls and their functions. (Figure 16)
- 2) Remember that the Round Bale Handler is designed and built to turn the bales and load them non stop, consequently, the direction of travel will usually be the same as the baler's.
- 3) When ready for the first bale, lower the loading arm to just a few inches above the ground, slow down this is a practice round, line up the machine so that the outer corner of the bale will touch at approximately 1/3 to 1/2 way up the angled part of the outer arm. (Figure 17)
- 4) Raise the loading arm as soon or slightly before the bale reaches the bottom of the "U". (Figure 18)
- 5) Keep raising the bale until it drops onto the platform. Do the same for loading the second row. Then start lowering the loading arm in order to disengage the limit switch (there is a limit switch installed on the machine, preventing the bale ram and the dumping platform from being activated if the loading arm isn't lowered enough).

### Models P-6808, P-6812 & P-6816 only.

- 6) Momentarily actuate the ram control lever (ram switch in the "AUTO" position). The ram will index the two bales toward the rear and will automatically return to the front position.
- 7) Once accustomed to the machine and its operation, you will notice that by slightly altering the alignment of the bale relative to the outside loading arm, you will be able to turn it and load it much more rapidly. In this case, the bale should hit the loading arm slightly closer to the heel.

4

## START-UP (cont'd)

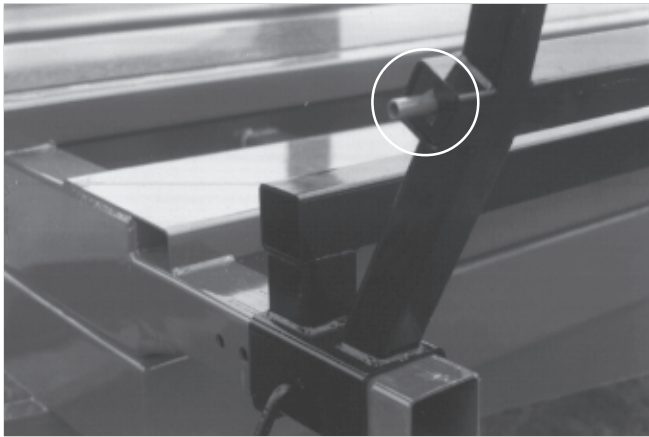

4 Figure 19

**Models P-6812, P-6812M, P-6816 & P-6816M only.**

7) When the first pair of bales loaded reach the bale supports at the extreme rear end of the platform, an indicator will pop out on the front corner of the platform opposite from the loading arm. (Figure 19)

8) To unload the bales, simply back up to the area where you wish to deposit the bales, open up the loading arm slightly to clear the platform. Raise the platform fully, then slowly move forward.



Figure 20

**Model P-6808 & P-6808M only.**

9) The P-6808 and P-6808M models permits to unload 2 stacks of 3 bales high vertically (Fig. 20), by using the vertical forks at rear (Fig. 21) included with the machine. Therefore, the loading capacity is limited to 6 bales (4' long bales).

10) To unload in rows on the ground, the rear bale support must be used, which permits maximum capacity load of 8 bales. A maximum angle indicator is installed on the machine. When the yellow pin appears, the ideal unload angle is reached (Fig.22).



Figure 21



Figure 22

---

---

## ***MAINTENANCE***

---

**The Auto-Load Round Bale Handler is designed to save you energy, time and money, take care of it, protect your investment.**

- 1) Wipe off all grease fittings with a clean cloth before adding grease to avoid injecting contaminants.
- 2) Repair or replace damaged grease fittings.
- 3) Lubricate all grease fittings every 20 hours of operation. (Do not forget the Bale Ram, 4 bronze bushings).
- 4) Open, clean and lubricate wheel bearings once a year.
- 5) Check nuts and bolts once a year. If necessary, use torque chart page 48.
- 6) Check all bolts on wheels after the first 5 hours of operation and then every 50 hours.
- 7) Check tire pressure every 50 hours. Adjust according to manufacturer's recommendations indicated on the tires.
- 8) Keep your equipment clean, it is good practice.

---

---

## ***STORAGE***

---

- 1) Store the Auto-Load Round Bale Handler in a cool, dry place.
- 2) Keep tires off the ground and cover them if left exposed to the sun.
- 3) Keep all piston rod in the retracted position. This will assure better protection against the elements.
- 4) Clean your Auto-Load Round Bale Handler.
- 5) Thoroughly inspect all parts of the Round Bale Handler. Replace or repair worn or defective parts.
- 6) Touch-up or repaint if necessary.
- 7) Lubricate all points before storage.

# SPECIFICATIONS

MODELS	P-6808	P-6808M	P-6812	P-6812M	P-6816	P-6816M
Gross Vehicle Weight Rating (tons)	8		12		16	
Diam. of bales	4' to 5 1/2' (6' opt.)		4' to 5 1/2' (6' opt.)		4' to 5 1/2' (6' opt.)	
Length of bales	4' to 5 1/2'		4' to 5 1/2'		4' to 5 1/2'	
Sides adjustable to bales ø	Std.		Std.		Std.	
4' b a l e s	Number of bales		6 vertical - 8 horizontal		12	
	Vertical unloading		2 stacks of 3 bales		---	
	Horizontal unloading		2 parallel rows of 4 bales		2 parallel rows of 6 bales	
5' b a l e s	Number of bales		4 vertical - 6 horizontal		10	
	Vertical unloading		2 stacks of 2 bales		---	
	Horizontal unloading		2 parallel rows of 3 bales		2 parallel rows of 5 bales	
Overall length	24' 9"		31' 7"		39' 7"	
Overall width	8' 6" to 10' 0"		8' 6" to 10' 0"		8' 6" to 10' 0"	
Platform height	44"		44"		44"	
Dumping angle	35 deg. and 90 deg.		35 degrees		35 degrees	
Tread width (c/c)	81½"		85"		81½"	
Hitch weight (empty)	1500 lbs.approx.		1800 lbs.approx.		2800 lbs.approx.	
Swivel hitch	Std.		Std.		Std.	
Automatic return of bale ram	Std.	-	Std.	-	Std.	-
Remote control	Std.	-	Std.	-	Std.	-
Axle	Simple		Tandem		Tandem	
Hub (capacity)	10000 lbs.		8000 lbs.		10000 lbs.	
Spindles (diameter)	3 1/4"		3 1/4"		3 1/4"	
Standard wheels (dimensions)	W16C16.1		W14C16.1		W16C16.1	
Optional wheels (dimensions)	-		W16C16.1		-	
Wheels (number of bolts)	8 bolts		8 bolts		8 bolts	
Standard tires	21.5L16.1/10ply		16.5L16.1/10ply		21.5L16.1/10ply	
Optional tires	-		21.5L16.1/10ply		-	
Oil flow recommended	15 to 18 gal. US/ min.		15 to 18 gal. US/ min.		15 to 18 gal. US/ min.	
Tractor required	65 to 80 HP		80 to 100 HP		100 to 150 HP	
Total weight	5700 lbs approx.		6800 lbs approx.		9500 lbs approx.	

Design and specifications subject to change without notice.

# AUTO-LOAD ROUND BALE HANDLER P-6808 & P-6808M

170-01117

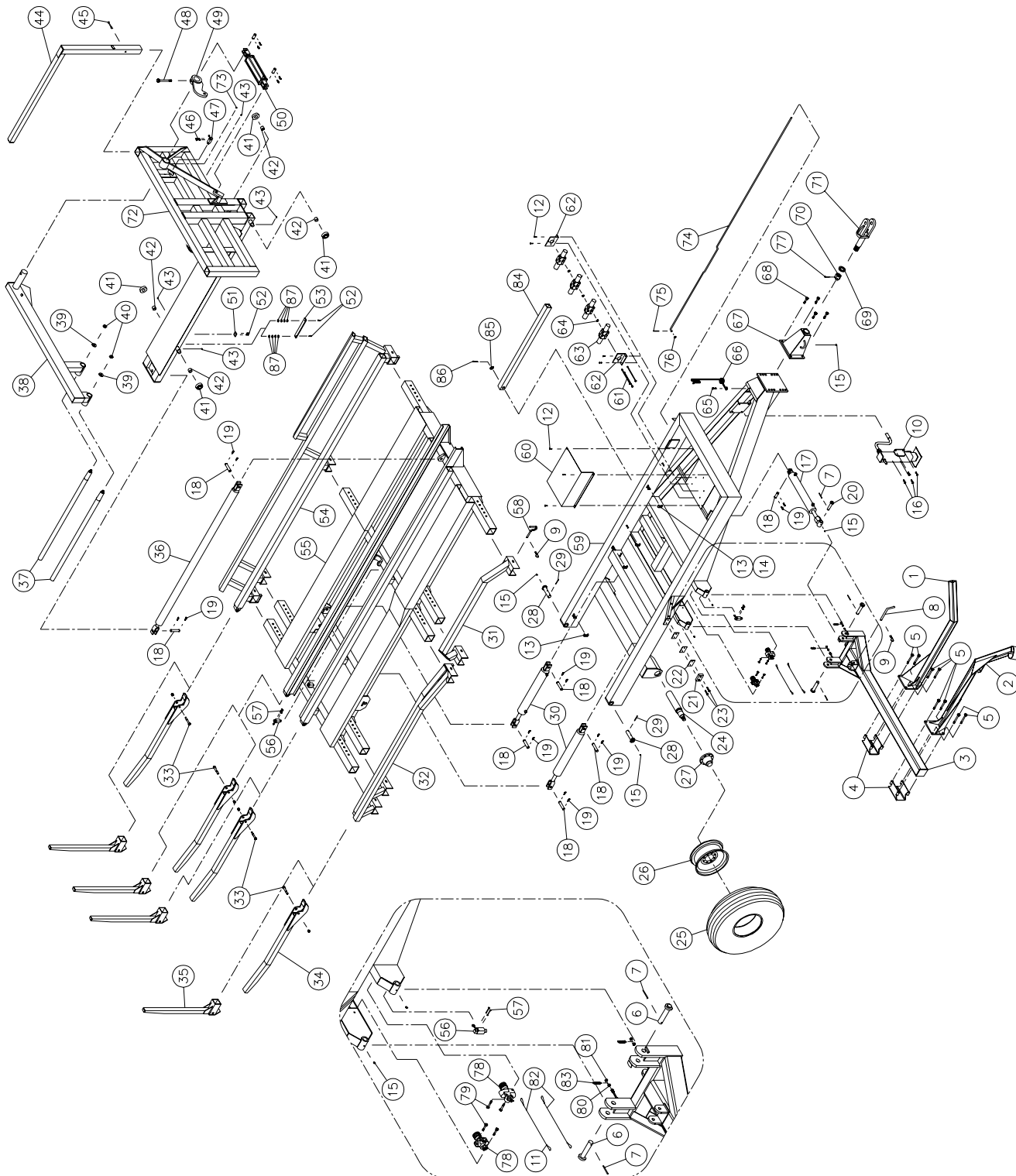

8



# AUTO-LOAD ROUND BALE HANDLER P-6808 & P-6808M (cont'd)

REF.	PART #	DESCRIPTION	QTY	
			P-6808	P-6808M
1	110-27061	Inner arm .....	1	1
2	120-00122	Outer arm .....	1	1
3	110-00382	Loading arm support .....	1	1
4	110-27101	Back plate .....	2	2
5	307-46490	Bolt 3/4" NF x 4 1/2" lg GR12 + nylon locknut .....	8	8
6	110-00411	Clevis pin 1 1/4" dia. x 6 3/8" lg .....	2	2
7	Std.	Roll pin 1/4" dia. x 2 " lg .....	3	3
8	150-00271	Pin .....	1	1
9	Std.	Hitch pin clip .....	10	10
10	110-20561	Jack 12 000 lbs (drop leg) .....	1	1
11	Std.	Wire clip 1/8" .....	-	4
12	300-32250	Bolt 1/4" NC x 1" lg + nylon locknut .....	7	3
13	140-00481	Collar 3" lg .....	8	6
14	140-04801	Collar 4 1/2" lg .....	-	2
15	Std.	Grease fitting 1/4-28 right .....	5	5
16	300-40310	Bolt 1/2" NC x 1 1/2" lg + nylon locknut .....	4	4
17	30AT20	Cylinder .....	1	1
18	150-01841	Clevis pin 1" dia. x 3 1/8" lg .....	7	7
19	Std.	Hairpin cotter .....	10	10
20	110-00431	Clevis pin 1" dia. x 5 3/8" lg .....	1	1
21	190-00071	Loading arm stopper .....	1	1
22	140-04671	Spacer .....	as required	
23	327-36310	Hexagonal socket set screw 3/8" NC x 1 1/2" lg .....	2	2
24	150-00142	Axle 3 1/4" dia. x 18" lg .....	2	2
25	PN-21.5L16.1	Tire 21.5L16.1 - 10 plys .....	2	2
26	W16C16.1	Rim 16.1 x 16 - 8 bolts .....	2	2
27	36133	Hub H10000 .....	2	2
28	110-00391	Clevis pin 1 1/2" dia. x 6 1/2" lg .....	2	2
29	Std.	Roll pin 1/4" dia. x 2 1/2" lg .....	4	4
30	35B24	Cylinder .....	2	2
31	110-00282	Front rail (right side) .....	1	1
32	120-00082	Rear rail (right side) .....	1	1
33	300-46490	Bolt 3/4" NC x 4 1/2" lg + nylon nut .....	4	4
34	110-06501	Rear horizontal forks .....	4	4
35	110-06511	Rear vertical forks .....	4	4
36	30FT84	Cylinder .....	1	1
37	150-00911	Forks for third row of bales (2) .....	opt.	opt.
38	110-03831	Loading arm for third row of bales .....	opt.	opt.
39	371-46000	Lock washer 3/4" (2) .....	opt.	opt.
40	336-46000	Nut 3/4" NC (2) .....	opt.	opt.
41	130-00591	Pusher wheel .....	4	4
42	160-00811	Bushing for pusher wheel 1 1/4" d.i. x 1 1/2" d.e. x 1 1/4" lg .....	4	4
43	Std.	Grease fitting 1/4-28 at 90 deg. .....	4	4
44	110-03851	Third bale guard rail .....	opt.	opt.
45	300-38490	Bolt 7/16" NC x 4 1/2" lg + nylon locknut (1) .....	opt.	opt.
46	322-20310	Square headed bolt 10-24 NC x 1 1/2" lg (2) .....	opt.	opt.
47	32254	Limit switch (1) .....	opt.	opt.
48	306-50640	Bolt 1" NC x 7" lg + nylon locknut (1) .....	opt.	opt.
49	110-04761	Third row lever .....	opt.	opt.



## AUTO-LOAD ROUND BALE HANDLER P-6808 & P-6808M (cont'd)

REF.	PART #	DESCRIPTION	QTY	
			P-6808 opt.	P-6808M opt.
50	30TR12	Cylinder + 2 clevis 1" dia. x 3" lg + 4 hairpin cotter .....	opt.	opt.
51	140-00411	Limit switch trip .....	1	1
52	300-32250	Bolt 1/4" NC x 1" lg + lock washer .....	4	4
53	140-00471	Limit switch trip .....	1	1
54	120-00091	Left rail .....	1	1
55	120-00071	Platform frame for P-6808 .....	1	1
56	32254	Limit switch .....	3	-
57	322-20310	Square headed bolt 10-24 NC x 1 1/2" lg .....	6	-
58	150-00281	Pin .....	9	9
59	120-00062	Frame P-6808 .....	1	1
60	130-00742	Valve shroud .....	1	1
61	110-20501	Threaded rod 3/8" NC x 9" lg + 2 nylon locknut .....	3	-
61	110-20491	Threaded rod 3/8" NC x 11 1/2" lg + 2 nylon locknut for third row option (3) ....	opt.	-
62	130-00731	Solenoid valve support .....	2	-
63	18019	Solenoid valve .....	3	-
63	18019	Additional solenoid valve for third row option .....	opt.	-
64	QR-4021	Quad ring .....	2	-
64	QR-4021	Additional quad ring for third row option .....	opt.	-
65	300-40310	Bolt 1/2" NC x 1 1/2" lg + nylon locknut .....	1	1
66	150-00291	Hoses support .....	1	1
67	120-00141	Hitch assy. ....	1	1
68	300-46400	Bolt 3/4" NC x 3" lg + nylon locknut .....	4	4
69	130-21111	Flat washer 1 13/16" i.d. x 3" o.d. ....	1	1
70	357-62000	Castle nut 1 3/4"-5 NC .....	1	1
71	110-00491	Swivel hitch .....	1	1
72	120-00132	Pusher .....	1	1
73	Std.	Grease fitting 1/4-28 straight (1) .....	opt.	opt.
74	150-00301	Ideal unload angle indicator .....	1	1
75	Std.	Cotter pin 5/32" dia. x 1 1/2" lg .....	1	1
76	376-40000	Flat washer 1/2" .....	1	1
77	Std.	Cutter pin 1/4" x 3 1/2" lg .....	1	1
78	644-10000	Cushion valve 3/8" NPT .....	-	2
79	300-38250	Bolt 7/16" NC x 1 " lg + nylon locknut .....	-	4
80	349-38500	Two-way locknut 7/16" NC .....	-	2
81	346-38000	Nylon locknut 7/16" NC .....	-	2
82	190-04591	Wire 1/8" x 15" .....	-	2
83	- - -	Spring 5/32" wire x 23/32" o.d. x 3 1/4" lg (included with valve 644-1000) .....	-	2
84	160-12781	Safety prop .....	1	1
85	376-50000	Flat washer 1" .....	1	1
86	Std.	Cotter pin 1/4" dia. x 2" lg .....	1	1
87	376-32000	Flat washer 1/4" .....	8	-



# AUTO-LOAD ROUND BALE HANDLER P-6812 & P-6812M

170-01069

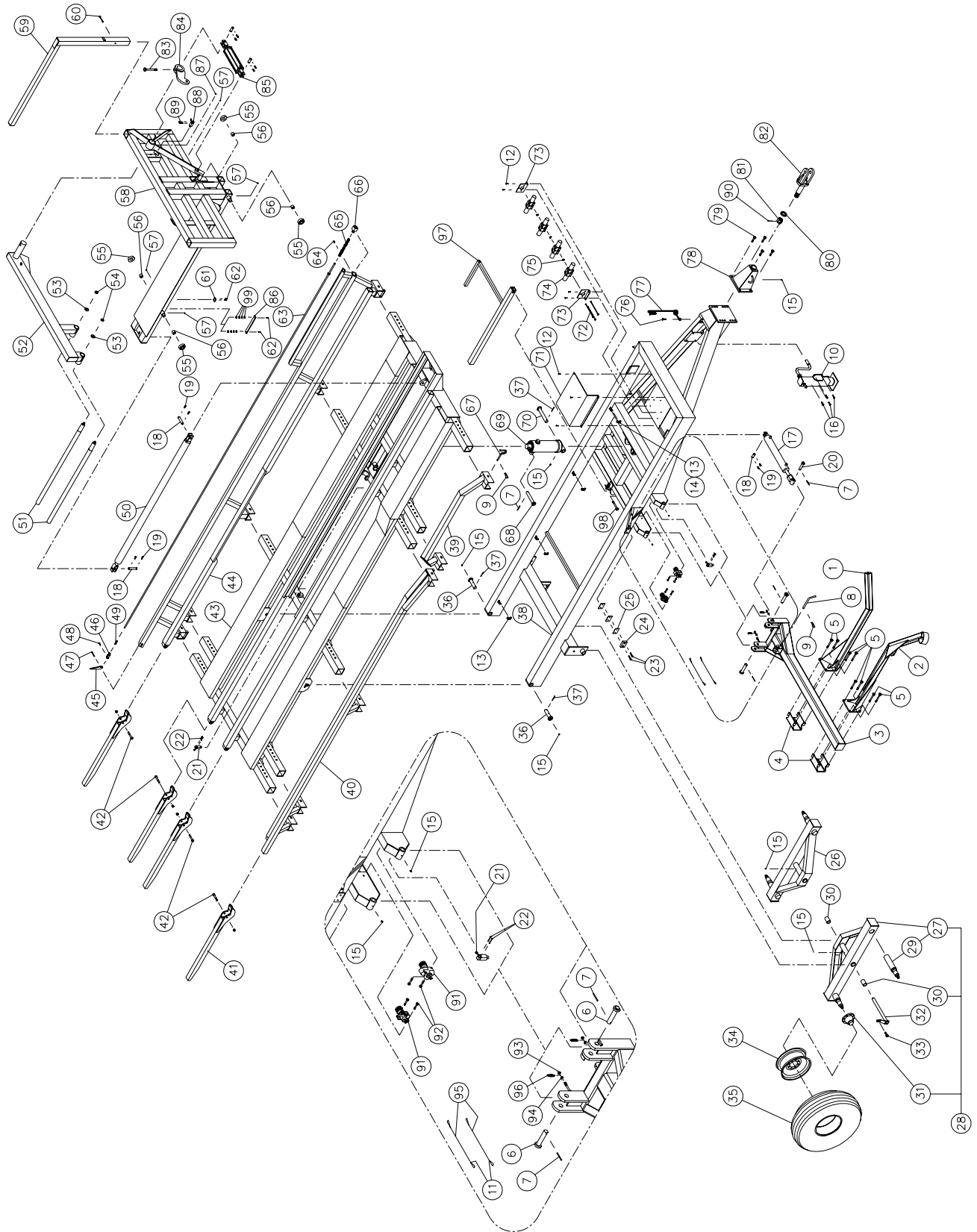

## AUTO-LOAD ROUND BALE HANDLER P-6812 & P-6812M (cont'd)

REF.	PART #	DESCRIPTION	QTY	
			P-6812	P-6812M
1	110-27061	Inner arm .....	1	1
2	120-00122	Outer arm .....	1	1
3	110-00382	Loading arm support .....	1	1
4	110-27101	Back plate .....	2	2
5	307-46490	Bolt 3/4" NF x 4 1/2" lg GR12 + nylon locknut .....	8	8
6	110-00411	Clevis 1 1/4" dia. x 6 3/8" lg .....	2	2
7	Std.	Roll pin 1/4" dia. x 2 " lg .....	3	3
8	150-00271	Pin .....	1	1
9	Std.	Hitch pin clip .....	12	12
10	110-20561	Jack 12 000 lbs (drop leg) .....	1	1
11	Std.	Wire clip 1/8" .....	-	4
12	300-32250	Bolt 1/4" NC x 1" lg + nylon locknut .....	7	3
13	140-00481	Collar 3" lg .....	8	6
14	140-04801	Collar 4 1/2" lg .....	-	2
15	Std.	Grease fitting 1/4-28 straight .....	8	8
16	300-40310	Bolt 1/2" NC x 1 1/2" lg + nylon locknut .....	4	4
17	30AT20	Cylinder .....	1	1
18	150-01841	Clevis 1" dia. x 3 1/8" lg .....	3	3
19	Std.	Hairpin cotter .....	6	6
20	110-00431	Clevis 1" dia. x 5 3/8" lg .....	1	1
21	32254	Limit switch .....	3	-
22	322-20310	Square headed bolt 10-24 NC x 1 1/2" lg .....	6	-
23	327-36310	Hexagonal socket set screw 3/8" NC x 1 1/2" lg .....	2	2
24	190-00071	Loading arm stopper .....	1	1
25	140-04671	Spacer .....	as required	
26	110-31402	Left tandem frame .....	1	1
26	110-31772	Left tandem frame .....	opt.	opt.
NI*	110-31403	Left tandem assembly .....	1	1
NI*	110-31773	Left tandem assembly .....	opt.	opt.
27	110-31404	Right tandem frame .....	1	1
27	110-31774	Right tandem frame .....	opt.	opt.
28	110-31401	Right tandem assembly .....	1	1
28	110-31771	Right tandem assembly .....	opt.	opt.
29	150-00213	Axle (welded) .....	4	4
29	150-06961	Axle (welded) .....	opt.	opt.
30	160-00661	Bushing 1 3/4" d.i. x 2" d.e. x 3" lg .....	4	4
31	36132	Hub H-8001 assembly .....	4	4
31	36133	Hub H-10000 assembly .....	opt.	opt.
32	110-27111	Clevis 1 3/4" dia. x 22 1/8" lg .....	2	2
33	302-46310	Bolt 3/4" NF x 1 1/2" lg + loctite .....	2	2
34	W14C16.1	Rim 16.1 x 14-8 bolts .....	4	4
34	W16C16.1	Rim 16.1 x 16-8 bolts .....	opt.	opt.
35	PN-165161	Tire 16.5 x 16.1 - 10 plys .....	4	4
35	PN-215161	Tire 21.5 x 16.1 - 10 plys .....	opt.	opt.
36	110-00391	Clevis pin 1 1/2" dia. x 6 1/2" lg .....	2	2
37	Std.	Roll pin 1/4" dia. x 2 1/2" lg .....	2	2
38	120-00043	Frame for P-6812 .....	1	1
39	110-00282	Front rail (right side) .....	1	1
40	120-03872	Rear rail (right side) .....	1	1
41	110-06471	Rear forks .....	4	4
42	300-46520	Bolt 3/4" NC x 5" lg + nylon nut + flat washer .....	4	4
43	120-00052	Platform for P-6812 .....	1	1
44	120-03881	Left rail .....	1	1
45	130-00701	Load indicator lever .....	1	1
46	51435	Yoke 1/2" NF + nut .....	1	1

## AUTO-LOAD ROUND BALE HANDLER P-6812 & P-6812M (cont'd)

REF.	PART #	DESCRIPTION	QTY	
			P-6812	P-6812M
47	300-34400	Bolt 5/16" NC x 3" lg + nylon locknut .....	1	1
48	Std.	Clevis + cotter pin 3/32" dia. x 3/4" lg .....	1	1
49	190-00051	Threaded rod 1/2" NF x 2 3/8" lg .....	1	1
50	30FT84	Cylinder .....	1	1
51	150-00911	Forks for third row of bales (2) .....	opt.	opt.
52	110-03831	Loading arm for third row of bales .....	opt.	opt.
53	371-46000	Lock washer 3/4" (2) .....	opt.	opt.
54	336-46000	Nut 3/4" NC (2) .....	opt.	opt.
55	130-00591	Pusher wheel .....	4	4
56	160-00811	Bushing for pusher wheel 1 1/4" d.i. x 1 1/2" d.e. x 1 1/4" lg .....	4	4
57	Std.	Grease fitting 1/2-28 elbow 90 deg. ....	4	4
58	120-00132	Pusher .....	1	1
59	110-03851	Third bale guard rail .....	opt.	opt.
60	300-38490	Bolt 7/16" NC x 4 1/2" lg + nylon locknut (1) .....	opt.	opt.
61	140-00411	Limit switch trip .....	1	1
62	300-32250	Bolt 1/4" NC x 1" lg + nylon locknut .....	4	4
63	110-09621	Rod for load indicator .....	1	1
64	300-34220	Bolt 5/16" NC x 3/4" lg + nylon locknut .....	1	1
65	610-023	Compression spring 1 3/16" d.e. x 11" lg .....	1	1
66	110-00521	Load indicator .....	1	1
67	150-00281	Pin .....	11	11
68	110-00421	Clevis .....	1	1
69	110-00471	Telescopic cylinder .....	1	1
70	110-00401	Clevis .....	1	1
71	130-00742	Valve shroud .....	1	1
72	110-20501	Threaded rod 3/8" NC x 9" lg + 2 nylon locknut .....	3	-
72	110-20491	Threaded rod 3/8" NC x 11 1/2" lg + 2 nylon locknut for third row option (3) ....	opt.	-
73	130-00731	Solenoid valve support .....	2	-
74	18019	Solenoid valve .....	3	-
74	18019	Additional solenoid valve for third row option (1) .....	opt.	-
75	QR-4021	Quad ring .....	2	-
75	QR-4021	Additional quad ring for third row option (1) .....	opt.	-
76	300-40310	Bolt 1/2" NC x 1 1/2" lg + 2 nylon locknut .....	1	1
77	150-00291	Hoses support .....	1	1
78	120-00141	Hitch assy. ....	1	1
79	300-46400	Bolt 3/4" NC x 3" lg + nylon locknut .....	4	4
80	130-21111	Flat washer 1 13/16" i.d. x 3" o.d. ....	1	1
81	357-62000	Castle nut 1 3/4"-5 NC .....	1	1
82	110-00491	Swivel hitch .....	1	1
83	306-50640	Bolt 1/2" NC x 7" lg + nylon locknut (1) .....	opt.	opt.
84	110-04761	Third row lever .....	opt.	opt.
85	30TR12	Cylinder + 2 clevis 1" dia. x 3" lg + 4 hairpin cotter .....	opt.	opt.
86	140-00471	Limit switch trip .....	1	1
87	Std.	Grease fitting 1/4-28 straight (1) .....	opt.	opt.
88	32254	Limit switch (1) .....	opt.	opt.
89	322-20310	Square headed bolt 10-24 NC x 1 1/2" lg (2) .....	opt.	opt.
90	Std.	Cotter pin 1/4" x 3 1/2" lg .....	1	1
91	644-10000	Cushion valve 3/8" NPT .....	-	2
92	300-38250	Bolt 7/16" NC x 1" lg + nylon locknut .....	-	4
93	349-38500	Two-way locknut 7/16" NC .....	-	2
94	346-38000	Nylon locknut 7/16" NC .....	-	2
95	190-04591	Wire 1/8" x 15" .....	-	2
96	- - -	Spring 5/32" wire x 23/32" o.d. x 3 1/4" lg (included with valve 644-1000) .....	-	2
97	110-24511	Safety prop .....	1	1
98	300-46520	Bolt 3/4" NC x 5" lg + nylon locknut .....	1	1
99	376-32000	Flat washer 1/4" .....	8	-

# AUTO-LOAD ROUND BALE HANDLER P-6816 & P-6816M

170-01617

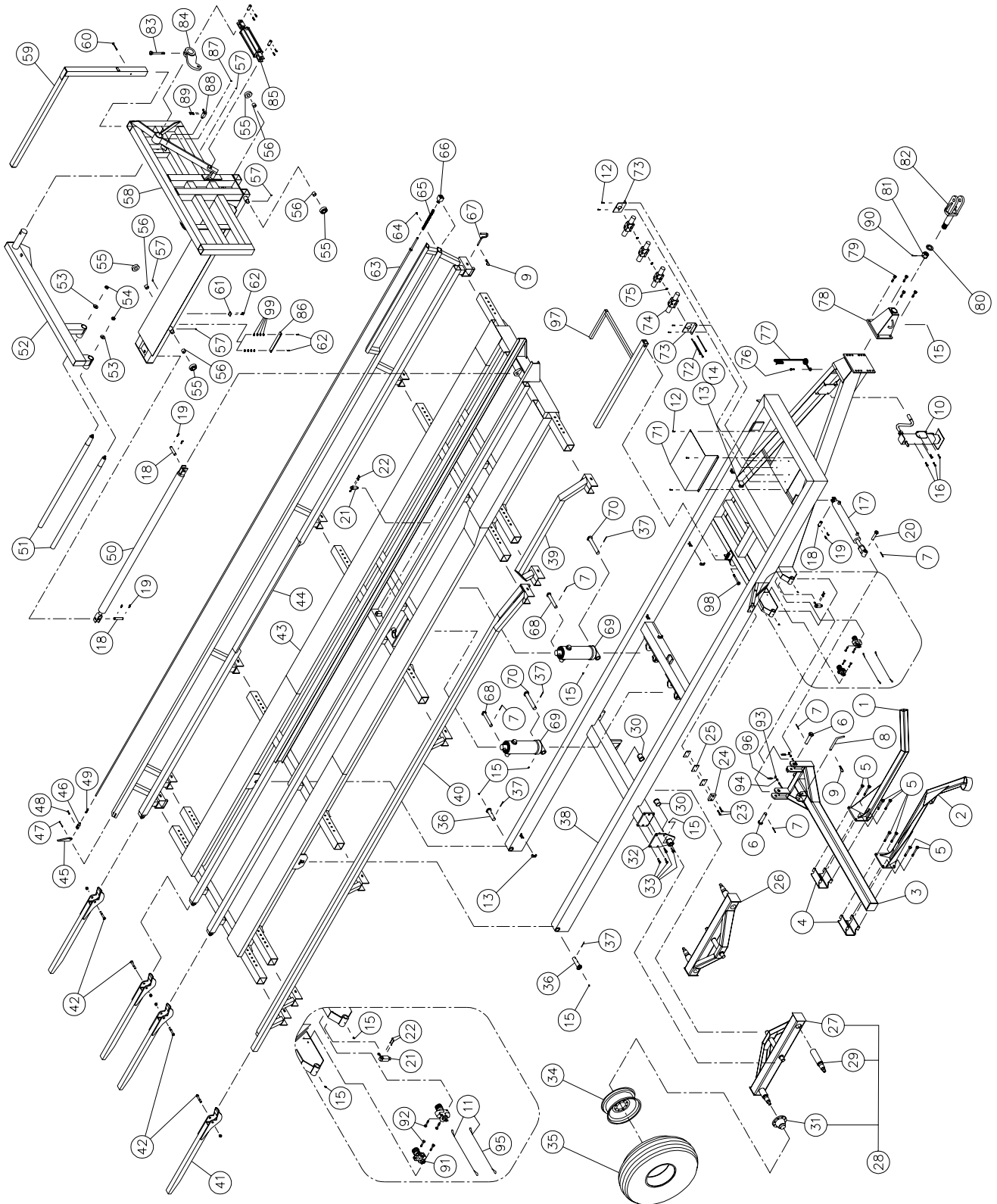

# AUTO-LOAD ROUND BALE HANDLER P-6816 & P-6816M (cont'd)

REF.	PART #	DESCRIPTION	QTY	
			P-6816	P-6816M
1	110-27061	Inner arm .....	1	1
2	120-00122	Outer arm .....	1	1
3	110-00382	Loading arm support .....	1	1
4	110-27101	Back plate .....	2	2
5	307-46490	Bolt 3/4" NF x 4 1/2" lg GR12 + nylon locknut .....	8	8
6	110-00411	Clevis 1 1/4" dia. x 6 3/8" lg .....	2	2
7	Std.	Roll pin 1/4" dia. x 2 " lg .....	5	5
8	150-00271	Pin .....	1	1
9	Std.	Hitch pin clip .....	14	14
10	110-20561	Jack 12 000 lbs (drop leg) .....	1	1
11	Std.	Wire clip 1/8" .....	-	4
12	300-32280	Bolt 1/4" NC x 1 1/4" lg + nylon locknut .....	7	3
13	140-00481	Collar 3" lg .....	8	6
14	140-04801	Collar 4 1/2" lg .....	-	2
15	Std.	Grease fitting 1/4-28 straight .....	11	11
16	300-40310	Bolt 1/2" NC x 1 1/2" lg + nylon locknut .....	4	4
17	30AT20	Cylinder .....	1	1
18	150-01841	Clevis 1" dia. x 3 1/8" lg .....	3	3
19	Std.	Hairpin cotter .....	6	6
20	110-00431	Clevis 1" dia. x 5 3/8" lg .....	1	1
21	32254	Limit switch .....	3	-
22	322-20310	Square headed bolt 10-24 NC x 1 1/2" lg .....	6	-
23	327-36310	Hexagonal socket set screw 3/8" NC x 1 1/2" lg .....	2	2
24	190-00071	Loading arm stopper .....	1	1
25	140-04671	Spacer .....	as required	
26	110-09125	Left tandem frame .....	1	1
NI*	110-09126	Left tandem assembly .....	1	1
27	110-09127	Right tandem frame .....	1	1
28	110-09128	Right tandem assembly .....	1	1
29	150-06961	Axle .....	4	4
30	160-15481	Bushing 2" d.i. x 2 1/2" d.e. x 2 1/2" lg .....	4	4
31	36133	Hub H-10000 assembly .....	4	4
32	110-27201	Plate for tandem .....	2	2
33	300-46400	Bolt 3/4" NC x 3" lg + nylon locknut .....	2	2
34	W16C16.1	Rim 16.1 x 16-8 bolts .....	4	4
35	PN-215161	Tire 21.5 x 16.1 - 10 plys .....	4	4
36	110-00391	Clevis 1 1/2" dia. x 6 1/2" lg .....	2	2
37	Std.	Roll pin 1/4" dia. x 2 1/2" lg .....	4	4
38	120-00232	Frame for P-6816 .....	1	1
39	110-00282	Front rail (right side) .....	1	1
40	120-01822	Rear rail (right side) .....	1	1
41	120-00101	Rear forks .....	4	4
42	300-46490	Bolt 3/4" NC x 4 1/2" lg + nylon lock .....	4	4
43	120-00242	Platform for P-6816 .....	1	1
44	120-01811	Left rail .....	1	1
45	130-00701	Load indicator lever .....	1	1
46	51435	Yoke 1/2" NF + nut .....	1	1
47	300-34400	Bolt 5/16" NC x 3" lg + nylon locknut .....	1	1
48	Std.	Clevis + cotter pin 3/32" dia. x 3/4" lg .....	1	1
49	190-00051	Threaded rod 1/2" NF x 2 3/8" lg .....	1	1
50	30FT84	Cylinder .....	1	1
51	150-00911	Forks for third row of bales (2) .....	opt.	opt.



## AUTO-LOAD ROUND BALE HANDLER P-6816 & P-6816M (cont'd)

REF.	PART #	DESCRIPTION	QTY	
			P-6816	P-6816M
52	110-03831	Loading arm for third row of bales .....	opt.	opt.
53	371-46000	Lock washer 3/4" (2) .....	opt.	opt.
54	336-46000	Nut 3/4" NC (2) .....	opt.	opt.
55	130-00591	Pusher wheel .....	4	4
56	160-00811	Bushing for pusher wheel 1 1/4" d.i. x 1 1/2" d.e. x 1 1/4" lg .....	4	4
57	Std.	Grease fitting 1/2-28 elbow 90 deg. ....	4	4
58	120-00132	Pusher .....	1	1
59	110-03851	Third bale guard rail .....	opt.	opt.
60	300-38490	Bolt 7/16" NC x 4 1/2" lg + nylon locknut (1) .....	opt.	opt.
61	140-00411	Limit switch trip .....	1	1
62	300-32250	Bolt 1/4" NC x 1" lg + lock washer .....	4	4
63	110-09631	Rod for load indicator .....	1	1
64	300-34220	Bolt 5/16" NC x 3/4" lg + nylon locknut .....	1	1
65	610-023	Compression spring 1 3/16" d.e. x 11" lg .....	1	1
66	110-00521	Load indicator .....	1	1
67	150-00281	Pin .....	13	13
68	110-00421	Clevis .....	2	2
69	110-00471	Telescopic cylinder .....	2	2
70	110-00401	Clevis .....	2	2
71	130-00742	Valve shroud .....	1	1
72	110-20501	Threaded rod 3/8" NC x 9" lg + 2 nylon locknut .....	3	-
72	110-20491	Threaded rod 3/8" NC x 11 1/2" lg + 2 nylon locknut for third row of bales (3) .....	opt.	-
73	130-00731	Solenoid valve support .....	2	-
74	18019	Additional solenoid valve .....	3	-
74	18019	Solenoid valve for third row of bales (1) .....	opt.	-
75	QR-4021	Quad ring .....	2	-
75	QR-4021	Additional quad ring for third row of bales (1) .....	opt.	-
76	300-40310	Bolt 1/2" NC x 1 1/2" lg + 2 nylon locknut .....	1	1
77	150-00291	Hoses support .....	1	1
78	120-00141	Hitch assy. ....	1	1
79	300-46400	Bolt 3/4" NC x 3" lg + nylon locknut .....	4	4
80	130-21111	Flat washer 1 13/16" i.d. x 3" o.d. ....	1	1
81	357-62000	Castle nut 1 3/4"-5 NC .....	1	1
82	110-00491	Swivel hitch .....	1	1
83	306-50640	Bolt 1" NC x 7" lg + nylon locknut (1) .....	opt.	opt.
84	110-04761	Third row lever .....	opt.	opt.
85	30TR12	Cylinder + 2 clevis 1" dia. x 3" lg + 4 hairpin cotter .....	opt.	opt.
86	140-00471	Limit switch trip .....	1	1
87	Std.	Grease fitting 1/4-28 straight (1) .....	opt.	opt.
88	32254	Limit switch (1) .....	opt.	opt.
89	322-20310	Square headed bolt 10-24 NC x 1 1/2" lg (2) .....	opt.	opt.
90	Std.	Cotter pin 1/4" x 3 1/2" lg .....	1	1
91	644-10000	Cushion valve 3/8" NPT .....	-	2
92	300-38250	Bolt 7/16" NC x 1" lg + nylon locknut .....	-	4
93	349-38500	Two-way locknut 7/16" NC .....	-	2
94	346-38000	Nylon locknut 7/16" NC .....	-	2
95	190-04591	Wire 1/8" x 15" lg .....	-	2
96	- - - -	Spring 5/32" wire x 23/32" o.d. x 3 1/4" lg (included with valve #644-10000) .	-	2
97	110-24511	Safety prop .....	1	1
98	300-46520	Bolt 3/4" NC x 5" lg + nylon locknut .....	1	1
99	376-32000	Flat washer 1/4" .....	8	-





## ***ELECTRIC SYSTEM P-6808 P-6812 & P-6816 (cont'd)***

REF.	PART #	DESCRIPTION	QTY
1	36100	Switch on-off .....	2
2	36101	Control lever 4 ways .....	1
3	18005	Fuse holder 10A .....	1
4	36102	Control box .....	1
5	36142	Harness 12 wires 16GA (12'6" lg) .....	1
6	36143	Harness 12 wires 16GA (15'6" lg) .....	1
7	36144	Harness 12 wires 16GA (5'6" lg) (black: 21'6", orange and blue/black: 49', green and blue: 58') .....	1
8	36145	12V accessories socket .....	1
9	18017	Limit switch .....	3
10	18017	Limit switch .....	opt.
11	36112	Two way valve (closed circuit) .....	opt.
12	36108	5 connector relay .....	1
13	36109	Single way diode .....	8
14	18019	Solenoid valve .....	3
15	18019	Solenoid valve .....	opt.
16	190-08381	Harness 16GA jaune (x' 0" lg) .....	1
17	36113	Control lever 2 ways .....	1
18	36146	Switch 3 way .....	1

# ELECTRIC SCHEMA "LADDER DIAGRAM"

110-29961

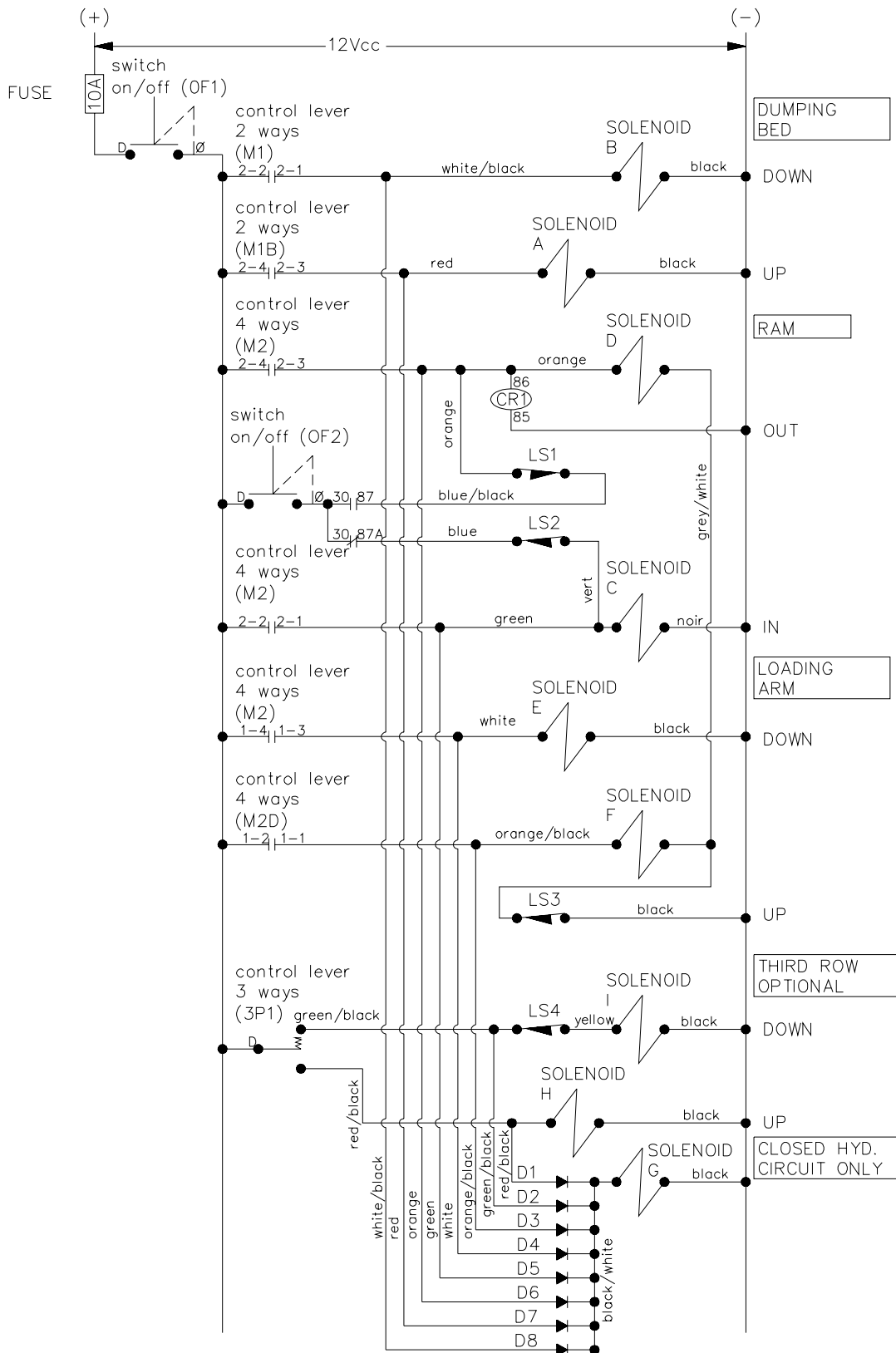

# HYDRAULIC SYSTEM P-6808

170-02287

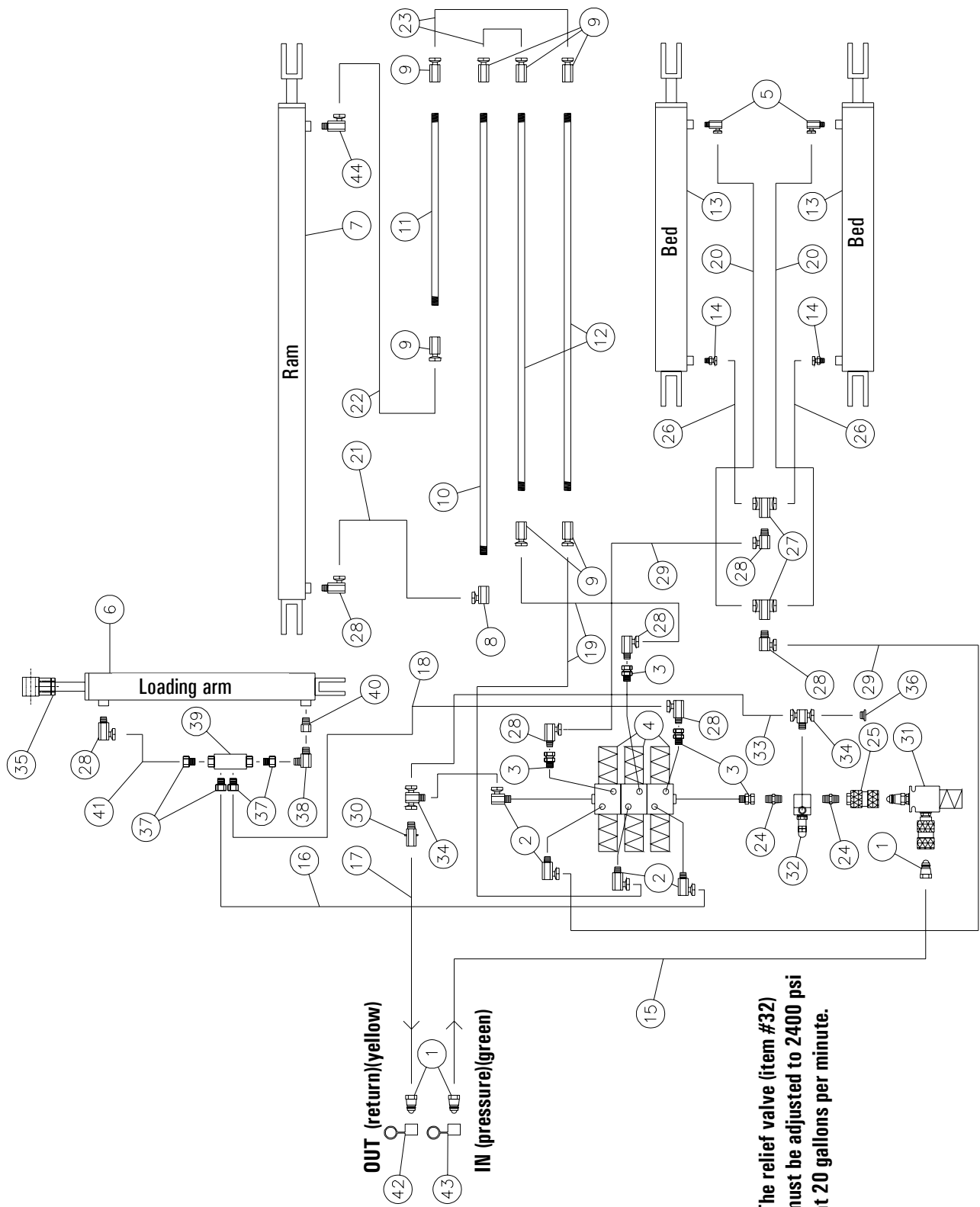

The relief valve (item #32) must be adjusted to 2400 psi at 20 gallons per minute.

# HYDRAULIC SYSTEM P-6808

REF.	PART #	DESCRIPTION	QTY
1	S71-4	Quick coupler 1/2" male .....	3
2	9515x8x8	Fitting 3/4" ORB male x 1/2" NPTF female 90° swivel .....	4
3	9315x8x8	Fitting 3/4" ORB male x 1/2" NPTF female straight swivel .....	4
4	18019	Solenoid valve .....	3
5	9405x6x6	Fitting 3/8" NPTM x 3/8" NPTF 90° swivel .....	2
6	30AT20	Arm cylinder .....	1
7	30FT84	Ram cylinder .....	1
8	9455x8x6	Fitting 3/8" NPTF x 1/2" NPTF 90° swivel .....	1
9	9255x8x6	Fitting 3/8" NPTF x 1/2" NPTF straight swivel .....	7
10	160-00491	Hydraulic line 3/8" x 127" lg .....	1
11	160-00471	Hydraulic line 3/8" x 43" lg .....	1
12	160-00481	Hydraulic line 3/8" x 97" lg .....	2
13	35B24	Dumping cylinder .....	2
14	9205x6x6	Fitting 3/8" NPTM x 3/8" NPTF straight swivel .....	2
15	190-00161	Hose 1/2" x 168" lg + 2 fittings 8U108 .....	1
16	190-00112	Hose 1/2" x 108" lg + 2 fittings 8U108 .....	1
17	190-00091	Hose 1/2" x 180" lg + 2 fittings 8U108 .....	1
18	190-00122	Hose 1/2" x 88" lg + 2 fittings 8U108 .....	1
19	190-00102	Hose 1/2" x 36" lg + 2 fittings 8U108 .....	2
20	190-00221	Hose 3/8" x 48" lg + 1 fitting 6U108 & 1 fitting 6U106 .....	2
21	190-00142	Hose 1/2" x 20" lg + 2 fittings 8U108 .....	1
22	190-00152	Hose 1/2" x 49" lg + 2 fittings 8U108 .....	1
23	190-00132	Hose 1/2" x 18" lg + 2 fittings 8U108 .....	2
24	C3069x8	Close nipple 1/2" NPTM .....	2
25	S75-4	Quick coupler 1/2" female .....	1
26	190-00231	Hose 3/8" x 26" lg + 1 fitting 6U108 & 1 fitting 6U106 .....	2
27	C3709x8	"T" 1/2" NPTF .....	2
28	9405x8x8	Fitting 1/2" NPTM x 1/2" NPTF 90° swivel .....	7
29	190-00241	Hose 1/2" x 108" lg + 2 fittings 8U108 .....	2
30	LT-50-0	Check valve 1/2" NPT .....	1
31	110-00651	Valve for closed center hydraulic system .....	opt.
32	JL50-2400	Relief valve .....	1
33	190-03671	Hose 1/2" x 22" lg + 2 fittings 8U108 .....	1
34	9457-08-08	"T" 1/2" NPSM x 1/2" NPTF .....	2
35	190-00241	Locknut 1 1/2" - 12 x 1/2" lg. ....	1
36	3159-08	Plug 1/2" - 14 .....	1
37	3269x10x08	Fitting 7/8" ORB male x 1/2" NPTF female .....	4
38	3529x8x8	Fitting 1/2" NPTF male x 1/2" NPTF male 90° .....	1
39	36137	Stop valve .....	1
40	190-06121	Restrictor 5/32" .....	1
41	190-06131	Hose 1/2" x 16" lg + 2 fittings 8U108 .....	1
42	36139	Female cap (yellow) .....	1
43	36140	Female cap (green) .....	1
44	9405x8x6	Adaptor 3/8" NPTF male x 1/2" NPSM female 90 deg. swivel .....	1

8



# HYDRAULIC SYSTEM P-6808M & THIRD ROW OPTION

REF.	PART #	DESCRIPTION	QTY
			P-6808M      OPTION
1	S71-4	Quick coupler 1/2" male .....	6 2
2	190-00231	Hose 3/8" x 26" lg + 1 fitting 6U108 + 1 fitting 6U106 .....	2 -
3	190-04531	Hose 1/2" x 232" lg + 2 fittings 8U108 .....	3 -
4	190-04541	Hose 1/2" x 152" lg + 2 fittings 8U108 .....	1 2
5	9405x8x8	Fitting 1/2" NPTM x 1/2" NPTF 90° swivel .....	6 2
6	30AT20	Arm cylinder .....	1 -
7	30FT84	Ram cylinder .....	1 -
8	9455x8x6	Fitting 3/8" NPTF x 1/2" NPTF 90° swivel .....	1 -
9	9255x8x6	Fitting 3/8" NPTF x 1/2" NPTF straight swivel .....	7 -
10	160-00491	Hydraulic line 3/8" x 127" lg .....	1 -
11	160-00471	Hydraulic line 3/8" x 43" lg .....	1 -
12	160-00481	Hydraulic line 3/8" x 97" lg .....	2 2
13	35B24	Dumping cylinder .....	2 -
14	9205x6x6	Fitting 3/8" NPTF x 3/8" NPTF straight swivel .....	2 -
15	190-04551	Hose 1/2" x 100" lg + 2 fittings 8U108 .....	1 -
16	644-10000	Cushion valve 3/8" NPT .....	2 -
17	190-04561	Hose 1/2" x 212" lg + 2 fittings 8U108 .....	1 -
18	190-00142	Hose 1/2" x 20" lg + 2 fittings 8U108 .....	1 -
19	190-00152	Hose 1/2" x 49" lg + 2 fittings 8U108 .....	1 -
20	190-00132	Hose 1/2" x 18" lg + 2 fittings 8U108 .....	2 -
21	190-03721	Stopper 1 1/2" -12 x 1/2" lg .....	1 -
22	190-04571	Hose 1/2" x 247" lg + 2 fittings 8U108 .....	1 -
23	9405x8x6	Fitting 3/8" NPTM x 1/2" NPTF 90° swivel .....	2 -
24	9205x8x6	Fitting 3/8" NPTM x 1/2" NPTF straight swivel .....	2 -
25	9385x6X6	Fitting 3/8" NPTF x 3/8" NPSM 45° swivel .....	- 2
26	9255x6x6	Fitting 3/8" NPTF x 3/8" NPTF straight swivel .....	- 2
27	190-03951	Hose 3/8" x ..." lg + 2 fittings 6U106 .....	- 2
28	160-06751	Hydraulic line 3/8" x 104" lg .....	- 2
29	9455x6x6	Fitting 3/8" NPTF x 3/8" NPTF 90° swivel .....	- 4
30	190-00771	Hose 3/8" x 20" lg+ 1 fitting 6U108 + 1 fitting 6U106 .....	- 1
31	30TR12	Cylinder for 3 <sup>rd</sup> row option .....	- 1
32	190-03871	Hose 3/8" x 34" lg+ 1 fitting 6U108 + 1 fitting 6U106 .....	- 1
33	9405x6x6	Fitting 3/8" NPTM x 3/8" NPTF 90° swivel .....	2 2
34	C3709x8	Fitting en «T» 1/2" NPTF .....	2 -
35	190-00221	Hose 3/8" x 48" lg + 1 fitting 6U108 + 1 fitting 6U106 .....	2 -
36	190-04581	Hose 1/2" x 60" lg + 2 fittings 8U108 .....	1 -
37	36139	Female cap (yellow) .....	2 -
38	36140	Female cap (green) .....	2 -
39	36138	Female cap (red) .....	2 -
40	36141	Female cap (blue) .....	- 2



# HYDRAULIC SYSTEM P-6812

170-02277R1

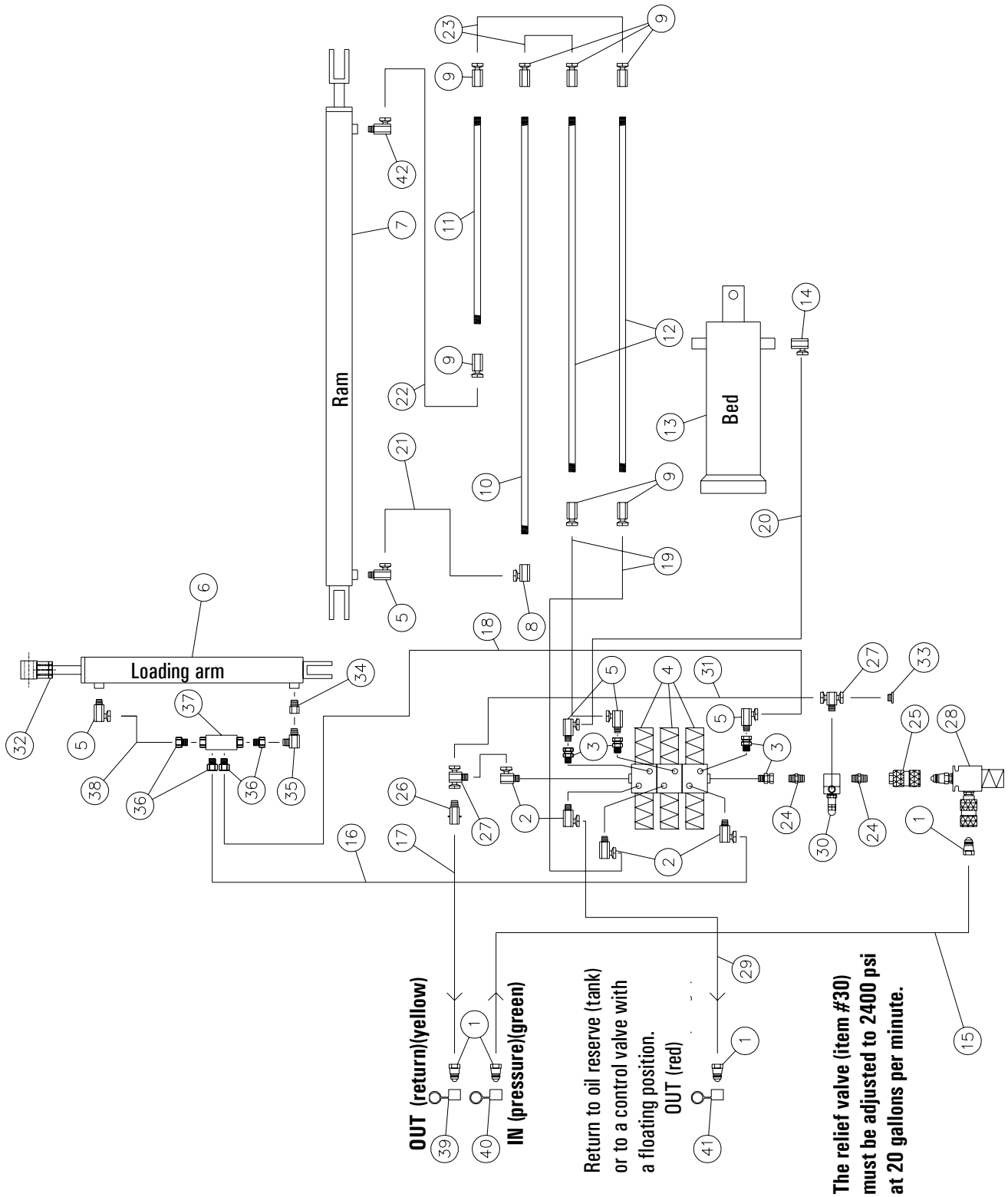



# HYDRAULIC SYSTEM P-6812

REF.	PART #	DESCRIPTION	QTY
1	S71-4	Quick coupler 1/2" male .....	4
2	9515x8x8	Fitting 3/4" ORB male x 1/2" NPTF femelle 90° swivel .....	4
3	9315x8x8	Fitting 3/4" ORB male x 1/2" NPTF femelle straight swivel .....	4
4	18019	Solenoid valve .....	3
5	9405x8x8	Fitting 1/2" NPTM x 1/2" NPTF 90° swivel .....	5
6	30AT20	Arm cylinder .....	1
7	30FT84	Ram cylinder .....	1
8	9455x8x6	Fitting 3/8" NPTF x 1/2" NPTF 90° swivel .....	1
9	9255x8x6	Fitting 3/8" NPTF x 1/2" NPTF straight swivel .....	7
10	160-01031	Hydraulic line 3/8" x 192" lg .....	1
11	160-01001	Hydraulic line 3/8" x 108" lg .....	1
12	160-01021	Hydraulic line 3/8" x 162" lg .....	2
13	110-00471	Telescopic cylinder .....	1
14	9455x8x8	Fitting 1/2" NPTF x 1/2" NPTF 90° swivel .....	1
15	190-00161	Hose 1/2" x 168" lg + 2 fittings 8U108 .....	1
16	190-00112	Hose 1/2" x 108" lg + 2 fittings 8U108 .....	1
17	190-00091	Hose 1/2" x 180" lg + 2 fittings 8U108 .....	1
18	190-00122	Hose 1/2" x 88" lg + 2 fittings 8U108 .....	1
19	190-00102	Hose 1/2" x 36" lg + 2 fittings 8U108 .....	2
20	190-00171	Hose 1/2" x 49" lg + 2 fittings 8U108 .....	1
21	190-00142	Hose 1/2" x 20" lg + 2 fittings 8U108 .....	1
22	190-00152	Hose 1/2" x 49" lg + 2 fittings 8U108 .....	1
23	190-00132	Hose 1/2" x 18" lg + 2 fittings 8U108 .....	2
24	C3069x8	Close nipple 1/2" NPTM .....	2
25	S75-4	Quick coupler 1/2" female .....	1
26	LT-50-0	Check valve 1/2" NPT .....	1
27	9457-08-08	"T" 1/2" NPSM x 1/2" NPTF .....	2
28	110-00651	Valve for closed center hydraulic system .....	opt.
29	190-02092	Hose 1/2" x 168" lg + 2 fittings + 1 fitting 8UR68 .....	1
30	JL50-2400	Relief valve .....	1
31	190-03671	Hose 1/2" X 22" lg + 2 fittings 8U108 .....	1
32	190-00241	Locknut 1 1/2" - 12 x 1/2" lg .....	1
33	3159-08	Plug 1/2" - 14 .....	1
34	190-06121	Restrictor 5/32" .....	1
35	3529x8x8	Fitting 1/2" NPTF male x 1/2" NPTF male 90° .....	1
36	3269x10x08	Fitting 7/8" ORB male x 1/2" NPTF female .....	4
37	36137	Stop valve .....	1
38	190-06131	Hose 1/2" x 16" lg + 2 fittings 8U108 .....	1
39	36139	Female cap (yellow) .....	1
40	36140	Female cap (green) .....	1
41	36138	Female cap (red) .....	1
42	9405x8x6	Adaptor 3/8" NPTF male x 1/2" NPSM female 90 deg. swivel .....	1



# HYDRAULIC SYSTEM P-6812M & THIRD ROW OPTION

170-02851R1

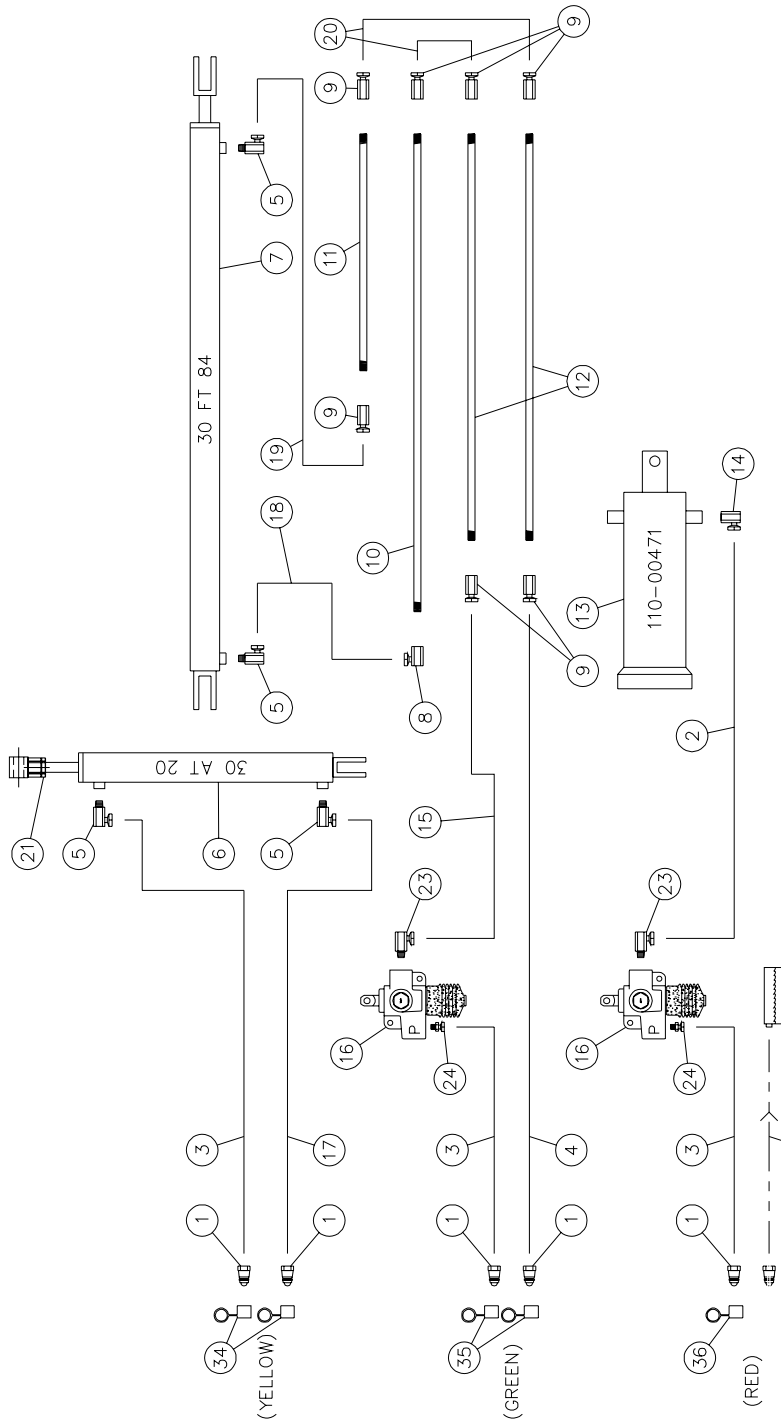

P-6812M

Third row option

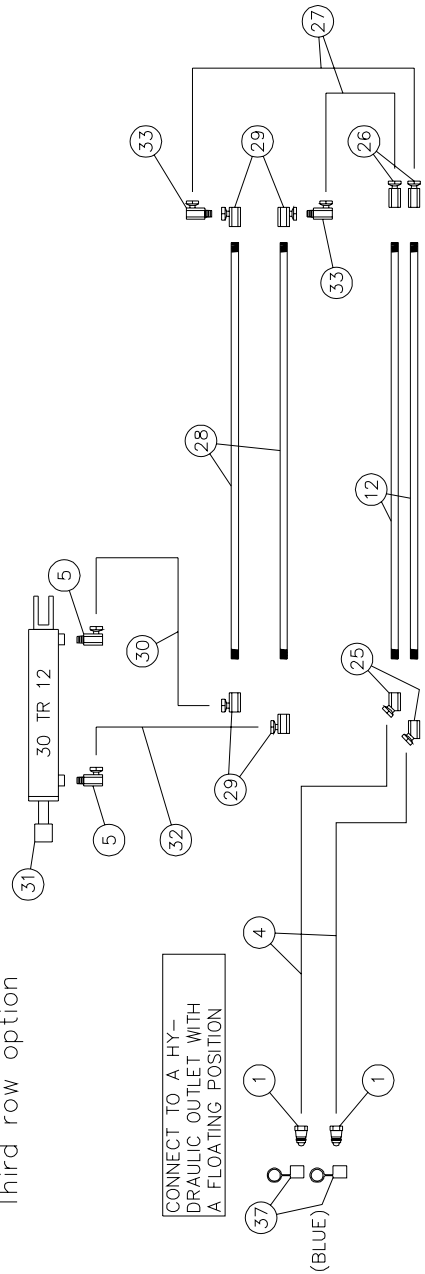

CONNECT TO A HYDRAULIC OUTLET WITH A FLOATING POSITION

## **HYDRAULIC SYSTEM P-6812M & THIRD ROW OPTION (cont'd)**

REF.	PART #	DESCRIPTION	QTY	
			P-6812M	OPTION
1	S71-4	Quick coupler 1/2" mâle .....	5	2
2	190-03861	Hose 1/2" x 60" lg + 2 fittings 8U108 .....	1	-
3	190-04531	Hose 1/2" x 232" lg + 2 fittings 8U108 .....	3	-
4	190-04541	Hose 1/2" x 152" lg + 2 fittings 8U108 .....	1	2
5	9405x8x8	Fitting 1/2" NPTM x 1/2" NPTF 90° swivel .....	4	2
6	30AT20	Arm cylinder .....	1	-
7	30FT84	Ram cylinder .....	1	-
8	9455x8x6	Fitting 3/8" NPTF x 1/2" NPTF 90° swivel .....	1	-
9	9255x8x6	Fitting 3/8" NPTF x 1/2" NPTF straight swivel .....	7	-
10	160-01031	Hydraulic line 3/8" x 180" lg .....	1	-
11	160-01001	Hydraulic line 3/8" x 108" lg .....	1	-
12	160-01021	Hydraulic line 3/8" x 162" lg .....	2	2
13	110-00471	Telescopic cylinder .....	1	-
14	9455x8x8	Fitting 1/2" NPTF x 1/2" NPTF 90° swivel .....	1	-
15	190-04551	Hose 1/2" x 100" lg + 2 fittings 8U108 .....	1	-
16	644-10000	Cushion valve 3/8" NPT .....	2	-
17	190-04561	Hose 1/2" x 212" lg + 2 fittings 8U108 .....	1	-
18	190-00142	Hose 1/2" x 20" lg + 2 fittings 8U108 .....	1	-
19	190-00152	Hose 1/2" x 49" lg + 2 fittings 8U108 .....	1	-
20	190-00132	Hose 1/2" x 18" lg + 2 fittings 8U108 .....	2	-
21	190-03721	Stopper 1 1/2" -12 x 1/2" lg .....	1	-
22		Hose 1/2" (return to oil reservoir) supplied by customer .....	1	-
23	9405x8x6	Fitting 3/8" NPTM x 1/2" NPTF 90° swivel .....	2	-
24	9205x8x6	Fitting 3/8" NPTM x 1/2" NPTF straight swivel .....	2	-
25	9385x6X6	Fitting 3/8" NPTF x 3/8" NPSM 45° swivel .....	-	2
26	9255x6x6	Fitting 3/8" NPTF x 3/8" NPTF straight swivel .....	-	2
27	190-00721	Hose 3/8" x 152" lg + 2 fittings 6U106 .....	-	2
28	160-06751	Hydraulic line 3/8" x 104" lg .....	-	2
29	9455x6x6	Fitting 3/8" NPTF x 3/8" NPTF 90° swivel .....	-	4
30	190-00771	Hose 3/8" x 20" lg + 1 fitting 6U108 + 1 fitting 6U106 .....	-	1
31	30TR12	Cylinder for 3 <sup>rd</sup> row option .....	-	1
32	190-03871	Hose 3/8" x 34" lg + 1 fitting 6U108 + 1 fitting 6U106 .....	-	1
33	9405x6x6	Fitting 3/8" NPTM x 3/8" NPTF 90° swivel .....	-	2
34	36139	Female cap (yellow) .....	2	-
35	36140	Female cap (green) .....	2	-
36	36138	Female cap (red) .....	1	-
37	36141	Female cap (blue) .....	-	2

# HYDRAULIC SYSTEM P-6816

170-02297R1

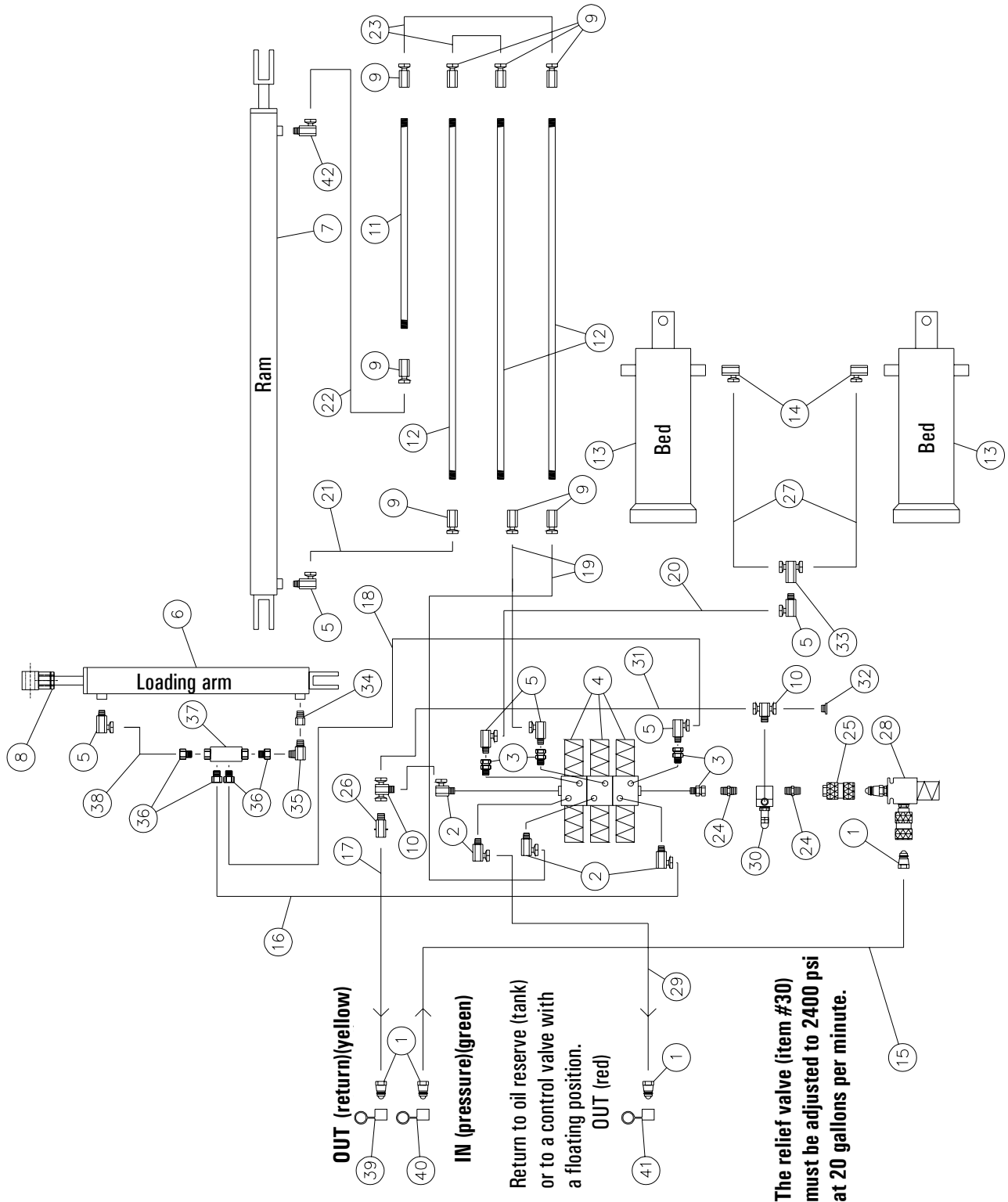

# HYDRAULIC SYSTEM P-6816

REF.	PART #	DESCRIPTION	QTY
1	S71-4	Quick coupler 1/2" male .....	4
2	9515x8x8	Fitting 3/4" ORB male x 1/2" NPTF female 90° swivel .....	1
3	9315x8x8	Fitting 3/4" ORB male x 1/2" NPTF female straight swivel .....	1
4	18019	Solenoid valve .....	3
5	9405x8x8	Fitting 1/2" NPTM x 1/2" NPTF 90° swivel .....	6
6	30AT20	Arm cylinder .....	1
7	30FT84	Ram cylinder .....	1
8	190-00241	Locknut 1 1/2" - 12 x 1/2" lg .....	1
9	9255x8x6	Fitting 3/8" NPTF x 1/2" NPTF straight swivel .....	7
10	9457x8x8	"T" 1/2" NPSM x 1/2" NPTF .....	2
11	160-01311	Hydraulic line 3/8" x 204" lg .....	1
12	160-01321	Hydraulic line 3/8" x 252" lg .....	3
13	110-00471	Telescopic cylinder 5 sections .....	2
14	9455x8x8	Fitting 1/2" NPTF x 1/2" NPTF 90° swivel .....	2
15	190-00161	Hose 1/2" x 168" lg + 2 fittings 8U108 .....	1
16	190-00112	Hose 1/2" x 108" lg + 1 fitting 8U108 & 1 fitting 8UR68 .....	1
17	190-00091	Hose 1/2" x 180" lg + 2 fittings 8U108 .....	1
18	190-00122	Hose 1/2" x 88" lg + 1 fitting 8U108 & 1 fitting 8UR68 .....	1
19	190-03222	Hose 1/2" x 42" lg + 2 fittings 8U108 .....	2
20	190-00351	Hose 1/2" x 158" lg + 1 fitting 8U108 & 1 fitting 8UR68 .....	1
21	190-03861	Hose 1/2" x 60" lg + 2 fittings 8U108 .....	1
22	190-00152	Hose 1/2" x 49" lg + 2 fittings 8U108 .....	1
23	190-00132	Hose 1/2" x 18" lg + 2 fittings 8U108 .....	2
24	C3069x8	Close nipple 1/2" NPTM .....	2
25	S75-4	Quick coupler 1/2" female .....	1
26	LT-50-0	Check valve 1/2" NPT .....	1
27	190-00341	Hose 1/2" x 34" lg + 2 fittings 8U108 .....	2
28	110-00651	Valve for closed center hydraulic system .....	opt.
29	190-02092	Hose 1/2" x 168" lg + 2 fittings 8U108 .....	1
30	JL50-2400	Relief valve .....	1
31	190-03671	Hose 1/2" x 22" lg + 2 fittings 8U108 .....	1
32	3159-08	Plug 1/2" - 14 .....	1
33	5855-08	"T" 1/2" NPSM x 1/2" NPTF .....	1
34	190-06121	Restrictor 5/32" .....	1
35	3529x8x8	Fitting 1/2" NPTF male x 1/2" NPTF male 90° .....	1
36	3269x10x08	Fitting 7/8" ORB male x 1/2" NPTF female .....	4
37	36137	Stop valve .....	1
38	190-06131	Hose 1/2" x 16" lg + 2 fittings 8U108 .....	1
39	36139	Female cap (yellow) .....	1
40	36140	Female cap (green) .....	1
41	36138	Female cap (red) .....	1
42	9405x8x6	Adaptor 3/8" NPTF male x 1/2" NPSM female 90 deg. swivel .....	1



# HYDRAULIC SYSTEM P-6816M & THIRD ROW OPTION

170-03231R1

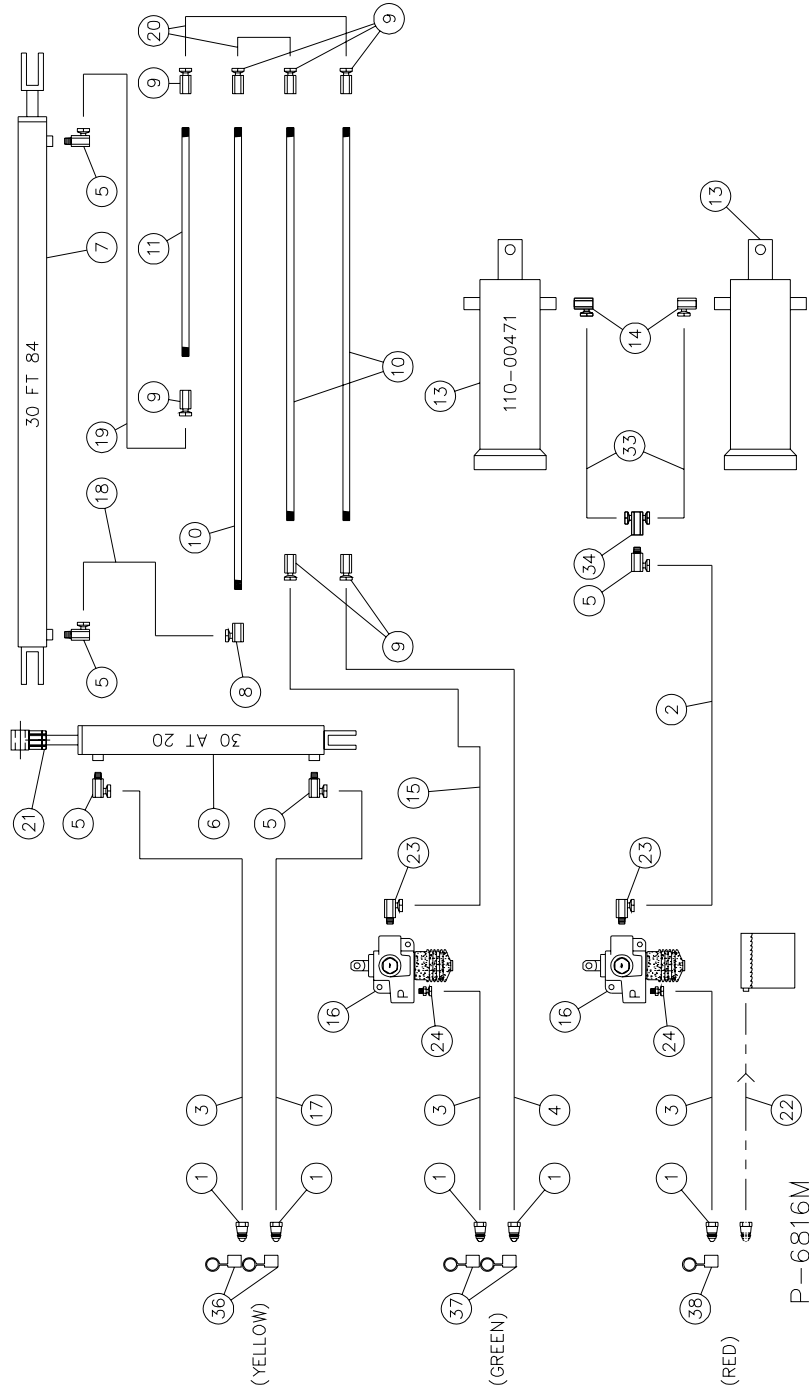

P-6816M

Third row option

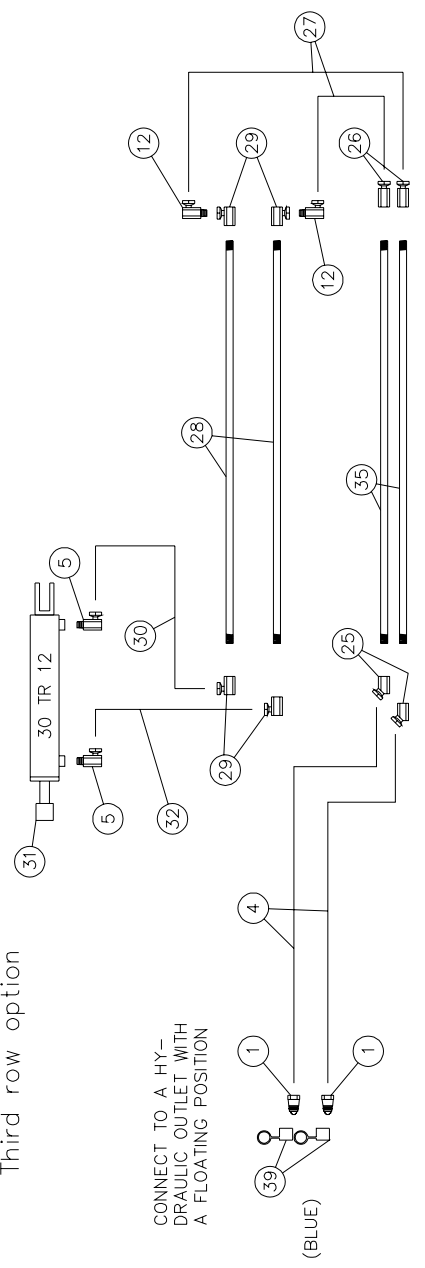

CONNECT TO A HYDRAULIC OUTLET WITH A FLOATING POSITION

## HYDRAULIC SYSTEM P-6816M & THIRD ROW OPTION (cont'd)

REF.	PART #	DESCRIPTION	QTY	
			P-6816M	OPTION
1	S71-4	Quick coupler 1/2" male .....	5	2
1	S71-4	Quick coupler 1/2" male .....	5	2
2	190-05551	Hose 1/2" x 136" lg + 2 fittings 8U108 .....	1	-
3	190-04531	Hose 1/2" x 232" lg + 2 fittings 8U108 .....	3	-
4	190-04541	Hose 1/2" x 152" lg + 2 fittings 8U108 .....	1	2
5	9405x8x8	Fitting 1/2" NPTM x 1/2" NPTF 90° swivel .....	5	2
6	30AT20	Arm cylinder .....	1	-
7	30FT84	Ram cylinder .....	1	-
8	9455x8x6	Fitting 3/8" NPTF x 1/2" NPTF 90° swivel .....	1	-
9	9255x8x6	Fitting 3/8" NPTF x 1/2" NPTF straight swivel .....	7	-
10	160-01321	Hydraulic line 3/8" x 252" lg .....	3	-
11	160-01311	Hydraulic line 3/8" x 204" lg .....	1	-
12	9405x6x6	Fitting 3/8" NPTM x 3/8" NPTF 90° swivel .....	-	2
13	110-00471	Telescopic cylinder 5 sections .....	2	-
14	9455x8x8	Fitting 1/2" NPTF x 1/2" NPTF 90° swivel .....	1	-
15	190-04551	Hose 1/2" x 100" lg + 2 fittings 8U108 .....	1	-
16	644-10000	Cushion valve 3/8" NPT (see detail p. 44) .....	2	-
17	190-04561	Hose 1/2" x 212" lg + 2 fittings 8U108 .....	1	-
18	190-00142	Hose 1/2" x 20" lg + 2 fittings 8U108 .....	1	-
19	190-00152	Hose 1/2" x 49" lg + 2 fittings 8U108 .....	1	-
20	190-00132	Hose 1/2" x 18" lg + 2 fittings 8U108 .....	2	-
21	190-03721	Stopper 1 1/2" -12 x 1/2" lg .....	1	-
22		Hose 1/2" (return to oil reservoir) supplied by customer .....	1	-
23	9405x8x6	Fitting 3/8" NPTM x 1/2" NPTF 90° swivel .....	2	-
24	9205x8x6	Fitting 3/8" NPTM x 1/2" NPTF straight swivel .....	2	-
25	9385x6X6	Fitting 3/8" NPTF x 3/8" NPSM 45° swivel .....	-	2
26	9255x6x6	Fitting 3/8" NPTF x 3/8" NPTF straight swivel .....	-	2
27	190-05561	Hose 3/8" x ___" lg + 2 fittings 6U106 .....	-	2
28	160-06751	Hydraulic line 3/8" x 104" lg .....	-	2
29	9455x6x6	Fitting 3/8" NPTF x 3/8" NPTF 90° swivel .....	-	4
30	190-00771	Hose 3/8" x 20" lg + 1 fitting 6U108 + 1 fitting 6U106 .....	-	1
31	30TR12	Cylinder for 3 <sup>rd</sup> row option .....	-	1
32	190-03871	Hose 3/8" x 34" lg + 1 fitting 6U108 + 1 fitting 6U106 .....	-	1
33	190-00341	Hose 1/2" x 34" lg + 2 fittings 8U108 .....	2	-
34	5856-08	"T" 1/2" NPSM .....	1	-
35	160-01021	Hydraulic line 3/8" x 162" lg .....	-	2
36	36139	Female cap (yellow) .....	2	-
37	36140	Female cap (green) .....	2	-
38	36138	Female cap (red) .....	1	-
39	36141	Female cap (blue) .....	-	2



# HYDRAULIC SYSTEM FOR 3<sup>rd</sup> ROW OPTION P-6808, P-6812 & P-6816

170-02421

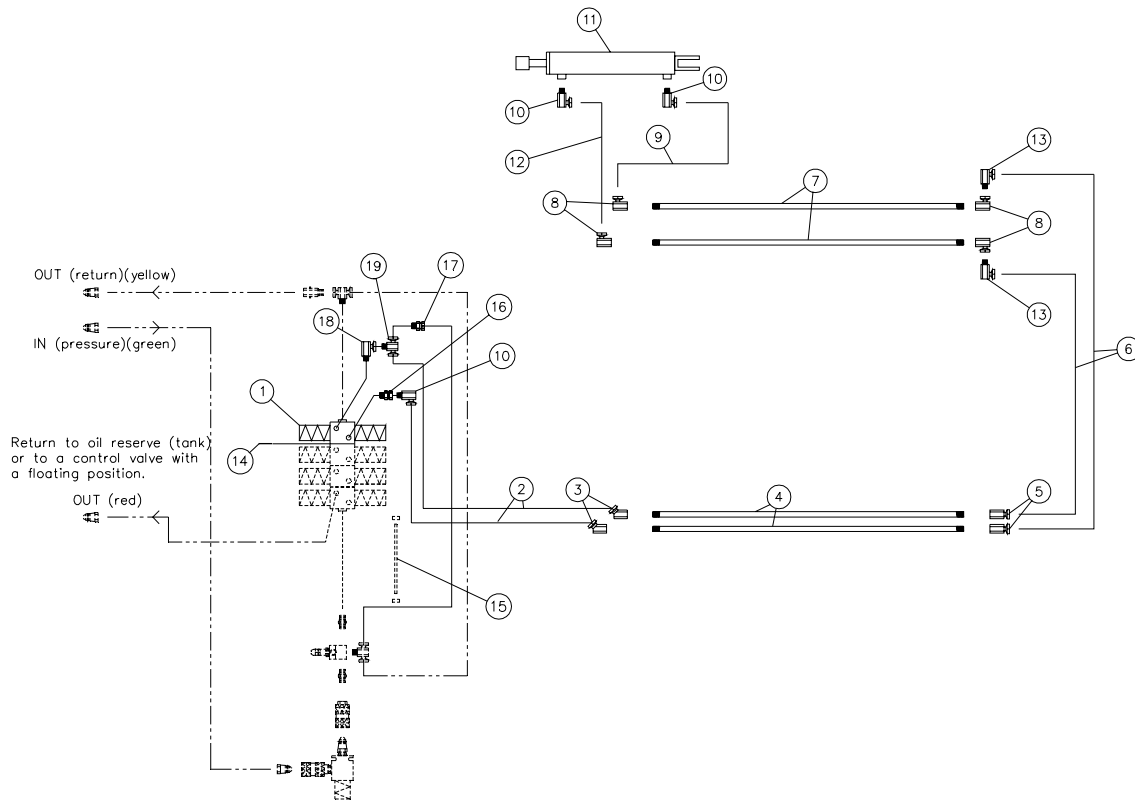

REF.	PART #	DESCRIPTION	QTY		
			P-6808	P-6812	P-6816
1	18019	Solenoid valve .....	1	1	1
2	190-00742	Hose 1/2" x 49" lg + 1 fitting 8U106 + 1 fitting 8U-R68 .....	2	2	2
3	9385x6x6	Fitting 3/8" NPTF x 3/8" NPSM 45° swivel .....	2	2	2
4	160-00481	Hydraulic line 3/8" x 97" lg .....	2	-	-
4	160-01021	Hydraulic line 3/8" x 162" lg .....	-	2	-
4	160-01321	Hydraulic line 3/8" x 252" lg .....	-	-	2
5	9255x6x6	Fitting 3/8" NPTF x 3/8" NPTF straight, swivel .....	2	2	2
6	190-03951	Hose 3/8" x ..." lg + 2 fittings 6U106 .....	2	-	-
6	190-00721	Hose 3/8" x 152" lg + 2 fittings 6U106 .....	-	2	-
6	190-03961	Hose 3/8" x ..." lg + 2 fittings 6U106 .....	-	-	2
7	160-06751	Hydraulic line 3/8" x 104" lg .....	2	2	2
8	9455x6x6	Fitting 3/8" NPTF x 3/8" NPTF 90° swivel .....	4	4	4
9	190-00771	Hose 3/8" x 20" lg + 1 fitting 6U108 + 1 fitting 6U106 .....	1	1	1
10	9405x8x8	Fitting 1/2" NPTM x 1/2" NPTF 90° swivel .....	2	2	2
11	30TR12	Cylinder for 3 <sup>rd</sup> row option .....	1	1	1
12	190-03871	Hose 3/8" x 34" lg + 1 fitting 6U108 + 1 fitting 6U106 .....	1	1	1
13	9405x6x6	Fitting 3/8" NPTM x 3/8" NPTF 90° swivel .....	2	2	2
14	Std.	Quad ring 1 1/32" o.d. x 29/32" i.d. x 1 1/16" .....	1	1	1
15	190-00781	Threaded rod 3/8" x 11 1/2" lg .....	3	3	3
16	9315x8x8	Fitting 3/4" - 16 x 1/2" - 14 .....	1	1	1
17	HSR882	Modified restrictor 3/16" .....	1	1	1
18	9515x8x8	Fitting 3/4" - 16 x 1/2" - 14 .....	1	1	1
19	15855x8x8x8	"T" .....	1	1	1





# CYLINDER 30AT20

110-00711

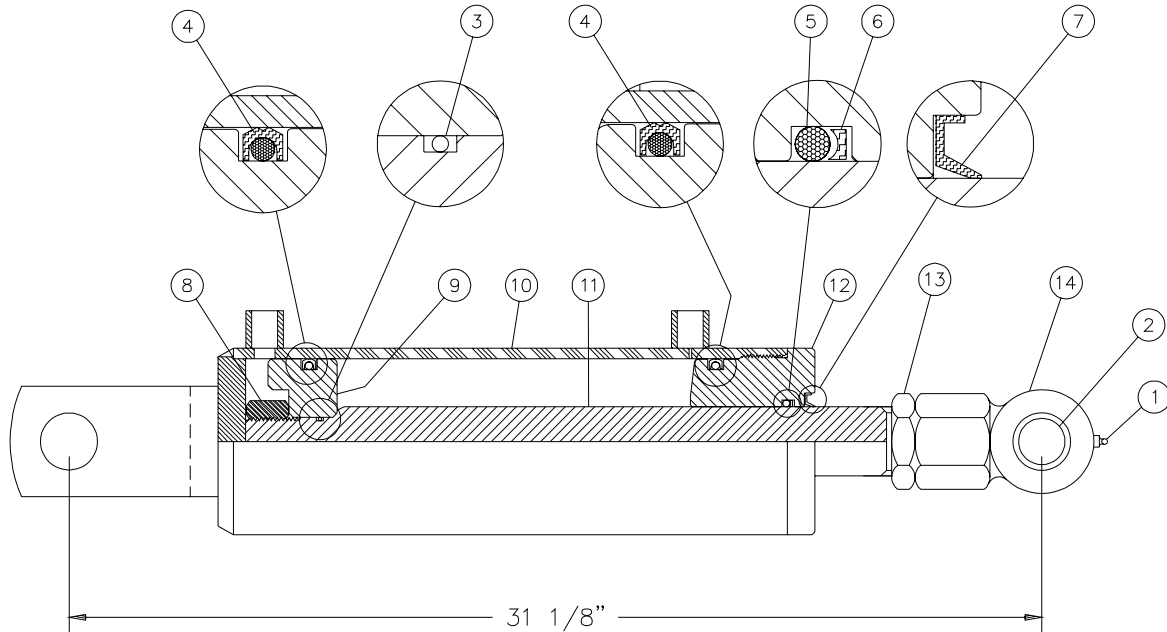

REF.	PART #	DESCRIPTION	QTY
1	Std.	Grease fitting 1/4" - 28 straight .....	1
2	D-6161	Bushing 1" i.d. x 1 1/4" o.d. x 2 1/2" .....	1
3	OR-018	O-ring 1/16" x 3/4" x 7/8" .....	1
4	PSP-334	O-ring 3/16" x 2 5/8" x 3" .....	2
5	OR-222	O-ring 1/8" x 1 1/2" x 1 3/4" .....	1
6	BU-222	Back-up 1/8" x 1 1/2" x 1 3/4" .....	1
7	AR-2269F0	Wiper 1/8" x 1 1/2" x 2" .....	1
8	Std.	Nut 7/8" - 14NF .....	1
9	150-06741	Piston 3" dia. ....	1
10	110-00891	Cylinder body 3" dia. ....	1
11	D-5000031	Piston rod 1 1/2" x 26 1/8" .....	1
12	D-5000041	Head 3" dia. ....	1
13	Std.	Stopper 1 1/2" - 12 x 1 1/2" .....	1
14	110-14621	Piston rod end 1 1/2" - 12 .....	1

8

# CYLINDER 35B24

110-00701

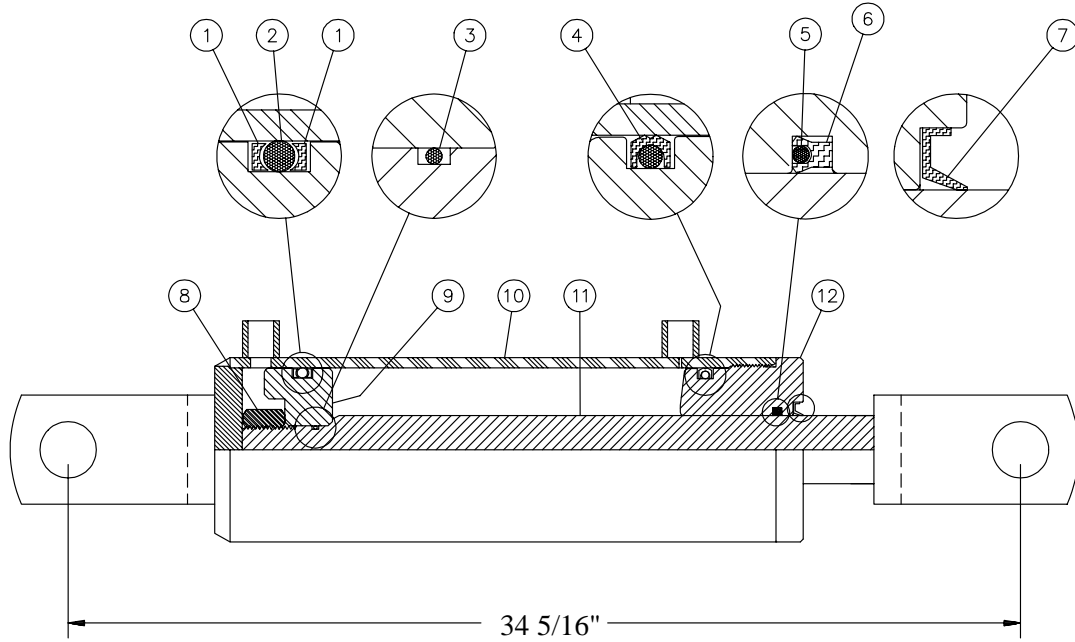

REF.	PART #	DESCRIPTION	QTY
1	BU-338	Back-up ring 3/16" x 3 1/8" x 3 1/2" .....	2
2	OR-338	O-ring 3/16" x 3 1/8" x 3 1/2" .....	1
3	OR-018	O-ring 1/16" x 3/4" x 7/8" .....	1
4	PSP-338	O-ring 3/16" x 3 1/8" x 3 1/2" .....	1
5	OR-222	O-ring 1/8" x 1 1/2" x 1 3/4" .....	1
6	BU-222	Back-up 1/8" x 1 1/2" x 1 3/4" .....	1
7	AR-2269F0	Wiper 1/8" x 1 1/2" x 1 3/4" .....	1
8	Std.	Nut 7/8" - 14NF .....	1
9	D-6113	Piston 3 1/2" dia. ....	1
10	D-A6157	Cylinder body 3 1/2" dia. ....	1
11	D-A6158	Piston rod 1 1/2" x 28 9/16" .....	1
12	D-6114	Head 3 1/2" dia. ....	1

8

# CYLINDER 30FT84

110-00691

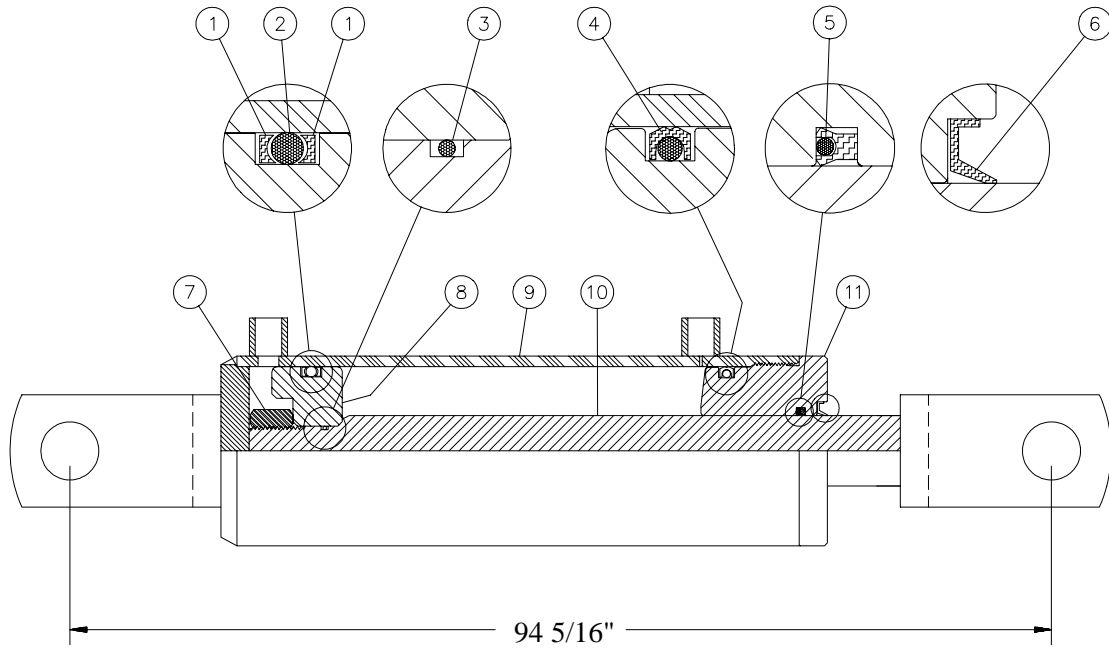

REF.	PART #	DESCRIPTION	QTY
1	BU-334	Back-up ring 3/16" x 2 5/8" x 3" .....	2
2	OR-334	O-ring 3/16" x 2 5/8" x 3" .....	1
3	OR-018	O-ring 1/16" x 3/4" x 7/8" .....	1
4	PSP-334	O-ring 3/16" x 2 5/8" x 3" .....	1
5	3C-375	U-cup 1 3/4" x 2 1/4" .....	1
6	CR-17240	Wiper 5/16" x 1 3/4" x 2 1/4" .....	1
7	Std.	Nut 7/8" - 14NF .....	1
8	D-6000	Piston 3" dia. ....	1
9	110-00881	Cylinder body 3" dia. ....	1
10	D-6126	Piston rod 1 3/4" x 85 9/16" .....	1
11	D-6106	Head 3" dia. ....	1

8

# CYLINDER 30TR12

15050

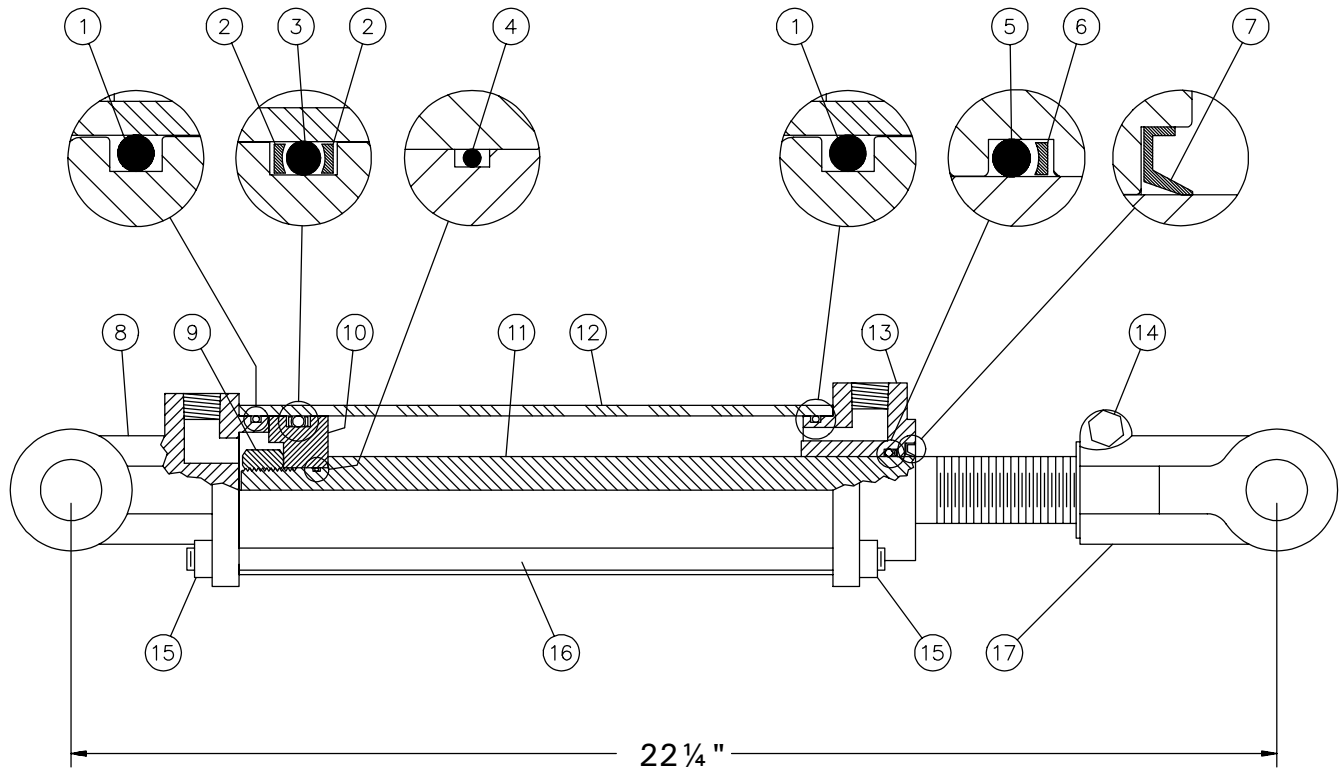

REF.	PART #	DESCRIPTION	QTY
1	See RK30TR	O-ring .....	2
2	See RK30TR	Back-up ring .....	2
3	See RK30TR	O-ring .....	1
4	See RK30TR	O-ring .....	1
5	See RK30TR	O-ring .....	1
6	See RK30TR	Back-up ring .....	1
7	See RK30TR	Wiper .....	1
8	492402	Yoke (for 3" tube) .....	1
9	Std.	Nut 3/4" NF .....	1
10	492432	Piston 3" ø .....	1
11	492042	Piston rod 1 1/4" .....	1
12	491742	Cylinder body 3" ø .....	1
13	492440	Cylinder head (for 3" tube) .....	1
14	Std.	Bolt 3/8" NC x 2 1/4" + nut .....	1
15	Std.	Nut 3/8" NC .....	8
16	Std.	Threaded rod 3/8" NC .....	4
17	458600	Yoke (for 1 1/4" rod) .....	1
NI*	8183	Pin 1" ø + cotter pin .....	2
NI*	RK30TR	Repair kit for cylinder 3" (includes # 1, 2, 3, 4, 5, 6, & 7) .....	1

\*NI = Not illustrated

8

# DIRECTIONAL CONTROL VALVE (Models «M» only)

170-00951

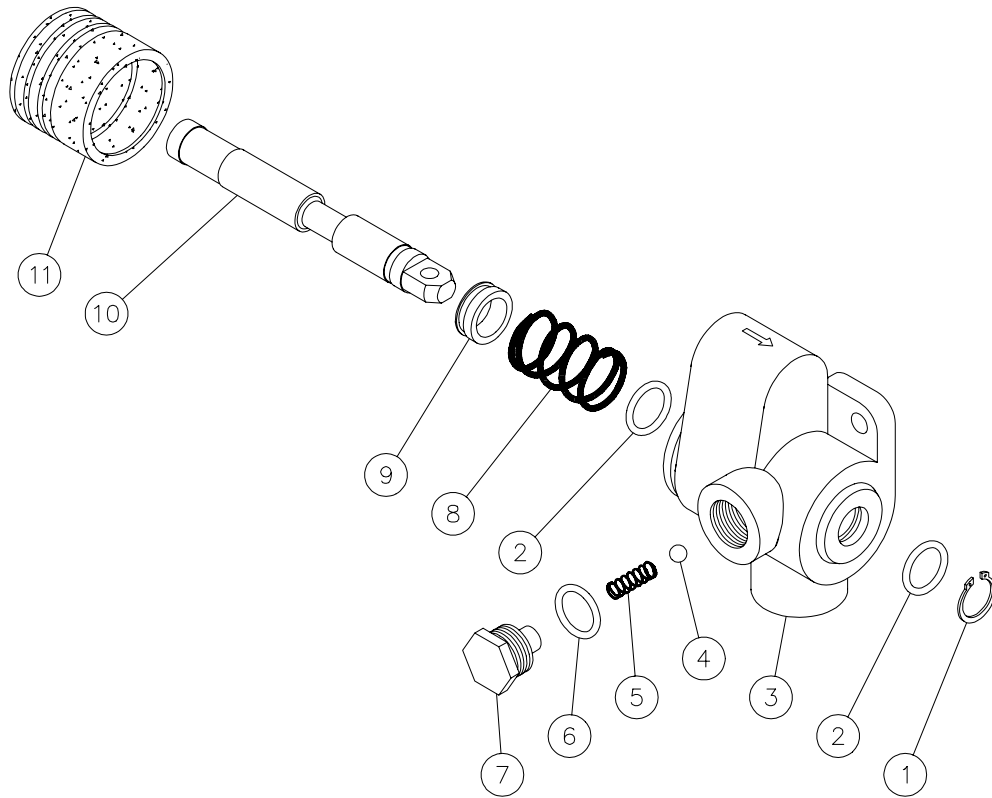

REF.	PART #	DESCRIPTION	QTY
1	649-00022	Snap ring .....	1
2	649-00023	O-ring .....	2
3	649-00024	Body .....	1
4	649-00025	Ball for pressure valve .....	1
5	649-00026	Spring for pressure valve .....	1
6	649-00027	O-ring .....	1
7	649-00028	Cap for pressure valve .....	1
8	649-00029	Spring .....	1
9	649-00030	Ring .....	1
10	649-00031	Spool .....	1
11	649-00032	Rubber boot .....	1

\* Some parts might not be available apart.



# TELESCOPIC CYLINDER 110-00471

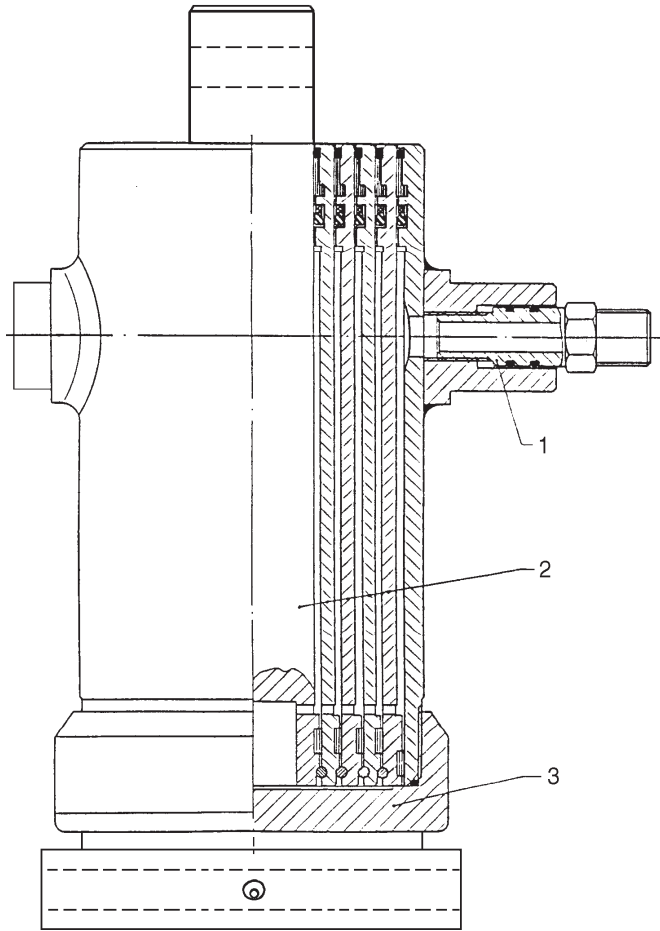

REF.	PART #	DESCRIPTION	QTY
1	51586	Connector .....	1
2	51595	Piston .....	1
3	110-00472	Threaded cylinder base .....	1
NI*	51597	Repair kit for cylinder .....	1
NI*	51589	Seal kit for connector .....	1

8

# HUBS H8001 (36132) H10000 (36133)

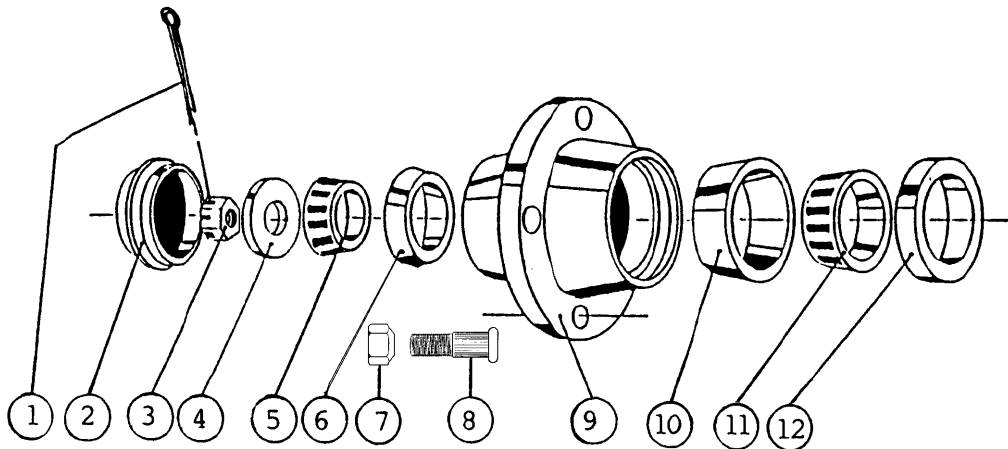







REF.	PART #	DESCRIPTION	QTY	
			H-8001	H-10000
1	Std.	Cotter pin 3/16" x 2 1/2" .....	1	-
1	Std.	Cotter pin 1/4" x 2 1/2" .....	-	1
2	36114	Dust cap 3.135" ø .....	1	-
2	36115	Dust cap 3.360" ø .....	-	1
3	36116	Castle nut 1" - 14 .....	1	-
3	36117	Castle nut 1 1/4" - 12 .....	-	1
4	Std.	Flat washer 1" .....	1	-
4	Std.	Flat washer 1 1/4" .....	-	1
5	36118	Roller bearing: cone no. LM 501349 .....	1	-
5	36119	Roller bearing: cone no. 4T-25580 .....	-	1
6	36120	Roller bearing: cup no. LM 501310 .....	1	-
6	36121	Roller bearing: cup no. 4T-25520 .....	-	1
7	36135	Nut 5/8" .....	8	8
8	36122	Stud 5/8" x 2 1/8" .....	8	8
9	36123	Hub only H8000 .....	1	-
9	36124	Hub only H10000 .....	-	1
10	36125	Roller bearing: cup no. LM 506810 .....	1	-
10	36126	Roller bearing: cup no. 4T-28921 .....	-	1
11	36127	Roller bearing: cone no. LM 506849 .....	1	-
11	36128	Roller bearing: cone no. 4T-28995 .....	-	1
12	36129	Oil seal no. CR27361 .....	1	-
12	36130	Oil seal no. CR29273 .....	-	1







# TORQUE CHART

## TORQUE SPECIFICATION TABLE

Thread UNC and UNF		Grade 2 				Grade 5   				Grade 8*   			
Bolt size		Torque				Torque				Torque			
Inches	mm	Pound feet		Newton meters		Pound feet		Newton meters		Pound feet		Newton meters	
		min.	max.	min.	max.	min.	max.	min.	max.	min.	max.	min.	max.
1/4	6.35	5	6	6.8	8.13	9	11	12.2	14.9	12	15	16.3	30.3
5/16	7.94	10	12	13.6	16.3	17	20.5	23.1	27.8	24	29	32.5	39.3
3/8	9.53	20	23	27.1	31.2	35	42	47.5	57.0	45	54	61.0	73.2
7/16	11.11	30	35	40.7	47.4	54	64	73.2	86.8	70	84	94.9	113.9
1/2	12.70	45	52	61.0	70.5	80	96	108.5	130.2	110	132	149.2	179.0
9/16	14.29	65	75	88.1	101.6	110	132	149.2	179.0	160	192	217.0	260.4
5/8	15.88	95	105	128.7	142.3	150	180	203.4	244.1	220	264	298.3	358.0
3/4	19.05	150	185	203.3	250.7	270	324	366.1	439.3	380	456	515.3	618.3
7/8	22.23	160	200	216.8	271.0	400	480	542.4	650.9	600	720	813.6	976.3
1	25.40	250	300	338.8	406.5	580	696	786.5	943.8	900	1080	1220.4	1464.5
1 1/8	25.58	-	-	-	-	800	880	1084.8	1193.3	1280	1440	1735.7	1952.6
1 1/4	31.75	-	-	-	-	1120	1240	1518.7	1681.4	1820	2000	2467.9	2712.0
1 3/8	34.93	-	-	-	-	1460	1680	1979.8	2278.1	2380	2720	3227.3	3688.3
1 1/2	38.10	-	-	-	-	1940	2200	2630.6	2983.2	3160	3560	4285.0	4827.4

\* Thick nuts must be used with grade 8 bolts.

Size of screw	Thread	Pitch (mm)	Grade 4T  				Grade 7T 				Grade 8T  			
			Torque				Torque				Torque			
			Pound feet		Newton meters		Pound feet		Newton meters		Pound feet		Newton meters	
		min.	max.	min.	max.	min.	max.	min.	max.	min.	max.	min.	max.	
M6	UNC	1.00	3.6	5.8	4.9	7.9	5.8	9.4	7.9	12.7	7.2	10	9.8	13.6
M8	UNC	1.25	7.2	14	9.8	19	17	22	23	29.8	20	26	27.1	35.2
M10	UNC	1.5	20	25	27.1	33.9	34	40	46.1	54.2	38	46	51.5	62.3
M12	UNC	1.75	28	34	37.9	46.1	51	59	69.1	79.9	57	66	77.2	89.4
M14	UNC	2.0	49	56	66.4	75.9	81	93	109.8	126	96	109	130.1	147.7
M16	UNC	2.0	67	77	90.8	104.3	116	130	157.2	176.2	129	145	174.8	196.5
M18	UNC	2.0	88	100	119.2	136	150	168	203.3	227.6	175	194	237.1	262.9
M20	UNC	2.5	108	130	146.3	176.2	186	205	252	277.8	213	249	288.6	337.4
M8	UNF	1.0	12	17	16.3	23	19	27	25.7	36.6	22	31	29.8	42
M10	UNF	1.25	20	29	27.1	39.3	35	47	47.4	63.7	40	52	54.2	70.5
M12	UNF	1.25	31	41	42	55.6	56	68	75.9	92.1	62	75	84	101.6
M14	UNF	1.5	52	64	70.5	86.7	90	106	122	143.6	107	124	145	168
M16	UNF	1.5	69	83	93.5	112.5	120	138	162.6	187	140	158	189.7	214.1
M18	UNF	1.5	100	117	136	158.5	177	199	239.8	269.6	202	231	273.7	313
M20	UNF	1.5	132	150	178.9	203.3	206	242	279.1	327.9	246	289	333.3	391.6

Use the above torques when special torque is not given.

NOTE: These values apply to fasteners as received from supplier, dry, or when lubricated with normal engine oil. They do not apply if extreme pressure lubricants are used.



---

---

## **WARRANTY**

---

PRONOVOST warrants this product to the initial purchaser for the period of one year from the date of purchase against defects in materials and workmanship.

We will replace or repair defective parts free of charge if they are returned to our plant in St-Tite, Quebec, Canada.

Transportation charges are the responsibility of the customer. This warranty is not transferable.

Tires are covered by the manufacturers of these items.

All PRONOVOST spare parts purchased are covered by a three (3) month warranty.

This warranty becomes void and nul if the equipment is modified, breaks down as result of an accident, if not operated according to manufacturer's recommendations, damaged by negligence or if maintenance has not been carried out as specified.

Our obligation is limited to the replacement or repair of the defective part. PRONOVOST accepts no responsibility for direct or indirect consequential damages of any kind.





Ce manuel est aussi disponible en français.  
Veuillez téléphoner.



**INNOVATION - EXCELLENCE**

**LES MACHINERIES PRONOVOST INC.**

260, route 159,

Saint-Tite, Quebec, Canada, G0X 3H0

Tel.: (418) 365-7551, Fax: (418) 365-7954

[www.pronovost.qc.ca](http://www.pronovost.qc.ca)