



Macerator 6620

Operator's Manual
April 2011



AgLand
INDUSTRIES INC.

Replacement Parts

To obtain prompt, efficient service, give the dealer the following information.

1. Correct stock number.
2. Model number of the machine.
3. Serial number of the machine.

The serial number is important in identifying your machine. It contains information for ordering replacement parts and options which may vary depending on the serial number identification.

Measurements are given in U.S. units followed by the equivalent in metric units. Hardware sizes are given in inches for U.S. hardware and millimeters for metric hardware.

All nuts and bolts are specified in Grade 5 unless otherwise indicated.

| | |
|----------------------------|-----------------------|
| AgLand | |
| Box 479 Arborg MB, R0C 0A0 | |
| Model #: | Macerator 6620 |
| Serial #: | |
| Made in Canada | |

Serial # on plate inside right side cover.

| | |
|--|------------|
| Warranty Registration Form | 3 |
| Introduction..... | 5 |
| Safety..... | 6-7 |
| Transport Safety | 6 |
| Operating Safety | 7 |
| Hydraulic Safety | 7 |
| Air Safety | 7 |
| Safety Decals | 8 |
| Specifications | 9 |
| Assembly | 10 |
| Assembly (Attachments) | 11-13 |
| Moldboard Merger | 11 |
| Spreader | 12 |
| Windrower..... | 13 |
| Tedder | 14-15 |
| Tedder Hydraulics..... | 16-17 |
| Field Set Up..... | 18-19 |
| PTO Speed..... | 18 |
| Pickup Height and Adjustment | 18 |
| Steel Roll Adjustment..... | 18 |
| Preparation (Air System) | 19 |
| Rubber Roll Pressure Adjustment | 19 |
| Steel Roll Pressure Adjustment..... | 19 |
| Maintenance | 20-23 |
| Checklist..... | 20 |
| Roll Drive Belt Replacement..... | 21 |
| Bearing Replacement..... | 22 |
| Replacing or Repacking Wheel Bearings | 22 |
| Pickup Teeth, Wrappers, and Wear Strips..... | 22 |
| Inch Torque Chart for Bolts and Nuts | 23 |
| Metric Torque Chart for Bolts and Nuts | 23 |
| Lubrication | 24 |
| Belts..... | 25 |
| Optional Kits..... | 26 |
| Troubleshooting | 27 |
| Warranty | Back Cover |

Congratulations, you have just purchased the new and improved AgLand Macerator 6620. To get the maximum benefit from your Macerator we suggest that you read this manual carefully.



The Macerator is designed to condition hay for a super fast dry down while maintaining the maximum amount of nutrients and color. The Macerator utilizes special steel rolls, each running at a different speed allowing for a measured nicking of the stem for greater air exposure. The low profile, heavy duty pickup allows for rapid operation with minimal leaf loss.

The roll system of the Macerator is designed to allow for the right amount of maceration without cutting up the hay.

These operating and maintenance instructions have been compiled from extensive field experience and engineering data. Some information is general in nature due to unknown and varying conditions. However, through experience and these instructions, you will be able to develop operating procedures suitable to your particular situation.

Please study this manual from the beginning to end BEFORE operating your new Macerator 6620. Pay special attention to the Safety section in this manual and the safety cautions on your equipment. Should anyone else operate this equipment be sure that they understand ALL safety, operating, and maintenance information presented in this manual.

The terms 'right' and 'left' as used throughout this manual, are determined by facing the direction the machine will travel when in use.

The photographs, illustrations, and data used in this manual were current at the time of printing, but due to possible inline production changes, your machine can vary slightly in detail. The Manufacturer reserves the right to redesign and change the machine as necessary without notification.

WARNING

Some pictures in this manual show the machine with shields removed to allow for a better view of the subject. The machine must never be operated with any of the shields removed.

AgLand Industries Inc. is a Canadian owned and operated company located in central Canada, in the province of Manitoba. AgLand was founded in 2001 by a group of innovative entrepreneurs that transformed their ideas and expertise into a leading manufacturing company of agricultural crop equipment.

Box 479, Arborg MB, Canada ROC OAO

Tel: 204.364.2211

Fax: 204.364.2472

Email: sales@aglandindustries.com

Web: www.aglandindustries.com



Safety

Read this manual completely and understand all operating instructions and precautions **BEFORE** attempting to operate or service your machine.

The safety information given in this manual does not replace safety codes, insurance needs, or state/province and local laws. Make sure your machine has the correct equipment needed as specified by the local laws and regulations.

Understand that your safety and the safety of others is measured by how you service and operate this machine.

IMPORTANT! Review and understand the positions and functions of all machine controls before operating this machine.

WARNING! Do **NOT** attempt any adjustments, maintenance, troubleshooting, or repairs while machine components are moving or activated with pressure.

- Lower machine to ground or onto appropriate blocks.
- Stop tractor engine and remove ignition key.
- Set tractor parking brake prior to leaving operator station.

Safety Alert Symbol



The Safety Alert symbol identifies important safety messages in the manual and on the machine. When you see this symbol, be alert to the possibility of personal injury or death. Follow all instructions in the safety message given. This symbol means attention, be alert, and your safety is involved.

Three Reasons To Follow Safety Instructions:

1. Accidents disable and kill.
2. Accidents cost.
3. Accidents can be avoided.

Slow Moving Vehicle Emblem



The Slow Moving Vehicle (SMV) emblem must be placed on the rear of the machine and be visible to traffic approaching the machine from the rear while traveling on public roads. Keep the SMV emblem clean and replace when damaged or emblem materials have faded. The SMV should only be displayed on the machine at road speeds less than 25 MPH (40 km/h).

Signal Words

DANGER

DANGER: Indicates an imminently hazardous situation that, if not avoided, **WILL** result in death or serious injury if proper precautions are not taken.

WARNING

WARNING: Indicates a potentially hazardous situation that, if not avoided, **COULD** result in death or serious injury if proper precautions are not taken.

CAUTION

CAUTION: Indicates a potentially hazardous situation that, if not avoided, **MAY** result in minor or moderate injury if proper practices are not taken, or serves as a reminder to follow appropriate safety practices.

Transport Safety

- The operator is responsible for complying with all local regulations regarding transporting agricultural equipment on public roads.
- Ensure all lights and reflectors, as required by local law, are in place, intact, and clean before transporting machine on public roads.
- Connect electrical socket on machine wiring harness to tractor receptacle.
- Ensure SMV emblem is clean and properly displayed, where required by law, before transporting machine on public roads.
- Do **NOT** allow riders on machine at any time, including transport of machine on public roads.
- Maximum transport speed is 20 MPH (32 km/h). Reduce speed on rough roads and surfaces.
- Use proper retainer on drawbar hitch pin and attach safety tow chain to tractor prior to transporting machine on public roads.
- Ensure that transport lock pin is installed and secured in the hole provided for transport.
- Tractor light switches should be set for road transport. Refer to tractor operator's manual for information.



Hitch and safety chain.

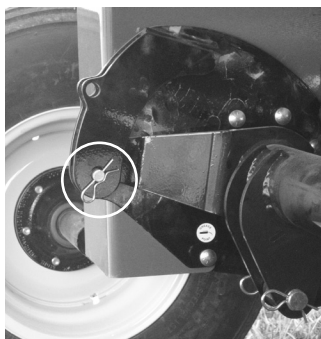

Lock travel pin in place.

Operating Safety

- REVIEW ALL SAFETY INSTRUCTIONS with all operators before allowing them to operate the equipment. Review instructions at least once each year.
- All shields and guards must be intact and in position and securely fastened before operating the Macerator.
- Only use a tractor equipped with ROPS cab and seat belt. Use caution when operating close to a road or building, the machine can throw stones and other objects during operation.
- Emphasize the importance of safety when working around and operating the machine.
- Do NOT allow riders on any part of the equipment at any time.
- Always keep hands, feet, and clothing away from moving parts.
- Always lower the Macerator to the ground when parking.
- Use transport lock pin and retainer to secure the lift linkage of the Macerator before transporting equipment.
- Use safety tow chain at all times.
- NEVER attempt to unplug the machine when the tractor is running and hydraulic system is pressurized.
- Keep hands, feet, and clothing away from the pickup area when in operation to avoid entanglement hazards. Do not open or remove shields or guards while machine is running.
- Relieve all pressure from hydraulic lines before disconnecting them. Before applying pressure to the system, make sure all connections are tight and that hoses and lines have not been damaged.

Hydraulic Safety

- Ensure that all components in the hydraulic system are kept in good condition.
- Replace any worn, cut, abraded, flattened, or crimped hoses and/or metal lines.
- Do not attempt any poorly executed repairs to hydraulic lines, fittings, or hoses by using tape, clamps, or cements. The hydraulic system operates under extremely high pressure: 1600 to 2300 PSI (11,033 to 15,859 kPa). Such repair will fail suddenly and create unsafe conditions.
- Wear proper hand and face protection (e.g. face shield) when searching for a high pressure hydraulic leak. Use a piece of wood or cardboard as a backdrop instead of hands. A high pressure concentrated stream of hydraulic fluid can pierce the skin. If such happens, seek immediate medical attention as infection and toxic reaction could develop.
- Before applying hydraulic pressure to the system, make sure all connections are tight and that lines, hoses, and couplings are not damaged.

Air Safety

- Make sure all hoses and bellows are kept in good condition and are clean.
- Replace any damaged lines or bellows.
- Do not exceed 120 PSI (827 kPa) air pressure in tank and 100 PSI (689 kPa) in air bags.

**Think Safety,
Work Safely!**

Operator's Manual Storage Container

Keep the Operator's Manual in the storage container provided on the Macerator. The Operator's Manual must be available for use by all operators.



Safety Decals

Moving Parts Hazard

! DANGER!



MOVING PARTS HAZARD

To prevent serious injury or death from moving parts:

- KEEP AWAY, Moving Parts can crush and dismember.
- Do not operate without guards and shields in place.
- Close and secure guards and shields before starting.
- Keep hands, feet, hair, and clothing away from moving parts.
- Disconnect and lockout power source before adjusting or servicing.
- Do not stand or climb on machine when operating.

DC0063

High Pressure Fluid Hazard

! WARNING!



HIGH PRESSURE FLUID HAZARD

To prevent serious injury or death:

- Relieve pressure on system before repairing, adjusting or disconnecting.
- Wear proper hand and eye protection when searching for leaks. Use wood or cardboard instead of hands.
- Keep all components in good repair.

DC0068

Keep Shields and Guards in Place

! DANGER!



KEEP SHIELDS AND GUARDS IN PLACE

DC0064

AgLand Macerator Model 6620

Dimensions

| | |
|-------------------------|--|
| Overall Width | 10'6" (3.20 m) |
| Length | 11'4" (3.45 m) |
| Height | operation 3'6" (1.07 m) transport 5'6" (1.68 m) |
| Weight (with windrower) | 4,334 lbs. (1966 kg) |

Tires (4)

| | |
|-------------------|----------------------|
| Tire Size | 11 L - 15 SL |
| Pressure | 20 PSI (138 kPa) |
| Wheel Hub | 6 bolt |
| Wheel Bolt Torque | 85 ft-lbs (115.3 Nm) |

Pickup

| | |
|----------------------|---------------------------------|
| Width | 5'6" (1.68 m) |
| Clearance* | 14" to 16" (35.6 cm to 40.6 cm) |
| Tooth Clearance** | 10" to 12" (24.5 cm to 30.5 cm) |
| Pickup Tooth Spacing | 2.75" (7 cm) |

* Under pickup when raised.

** When raised.

Rolls

| | |
|------------------------------------|----------------|
| Width of rubber feed rolls | 5'6" (1.68 m) |
| RPM of rubber feed rolls | 645 RPM |
| Minimum space between rubber rolls | 1/32" (0.8 mm) |
| Width of steel rolls | 5'6" (1.68 m) |
| RPM of top steel roll | 1372 RPM |
| RPM of bottom steel roll | 1514 RPM |
| Minimum space between steel rolls | 1/32" (0.8 mm) |

Tractor Requirements

Suggested tractor size* **Min. 80 HP - Max. 120 HP**
 (Min. 60 kW - Max. 89 kW)

Suggested min. under frame clearance 15" (38 cm)**

* Tractor should be of sufficient size to maintain operator control in all situations.

** To allow swath to flow freely under tractor.

Air System

| | |
|------------------------------|---------------------|
| Size of air pressure tank | 12 US Gallon (45 L) |
| Maximum air pressure in tank | 120 PSI (827.4 kPa) |

Hydraulic outlets required

1

Operating Speed

Approximate range* 5 to 10 MPH (8 to 16 km/h)

**Depending on crop conditions.*

Swath Size

Maximum Width 5' (1.52 m)

Cut Width

Recommended Width 14' to 16' (4.27 m to 4.88 m)

Capacity

Maximum 5.0 ton/acre (11.4 tonne/hectare)

Lubrication

NGLI No. 2 multi-purpose high temperature lithium base grease

Gear Box

SAE15W40 (Diesel Motor Oil) 2.6 US qt. (2.5 L)

Some weights and measurements are approximate.

All specifications, statements, and information shown in this manual are believed to be accurate at the time of printing. Specifications are subject to change without notice.

Assembly

Attaching Hitch

Sometimes the hitch will be shipped detached from the unit to allow for a more compact shipping package.

1. Bolt hitch to main frame, Figure 1, using fourteen 5/8" x 1-1/2" carriage bolts. Ensure all bolts are securely tightened.
2. Remove bearing on front of hitch (C), slide drive shaft (B) onto override clutch (A) through front bearing hole. Reinstall bearing and tighten shaft bolts on override clutch (A).
3. Install the long hydraulic hose (G) securely with the clamps (F) provided, as shown in Figure 2.
4. Torque required on 5/8" bolt for overriding clutch (A) is 65 ft-lbs (88.1 Nm).

- A. Override Clutch
- B. Drive Shaft
- C. Front Hitch Bearing
- D. A Frame Cover (Back)
- E. A Frame Cover (Front)
- F. Hose Clamp
- G. Long Hydraulic Hose

Figure 1

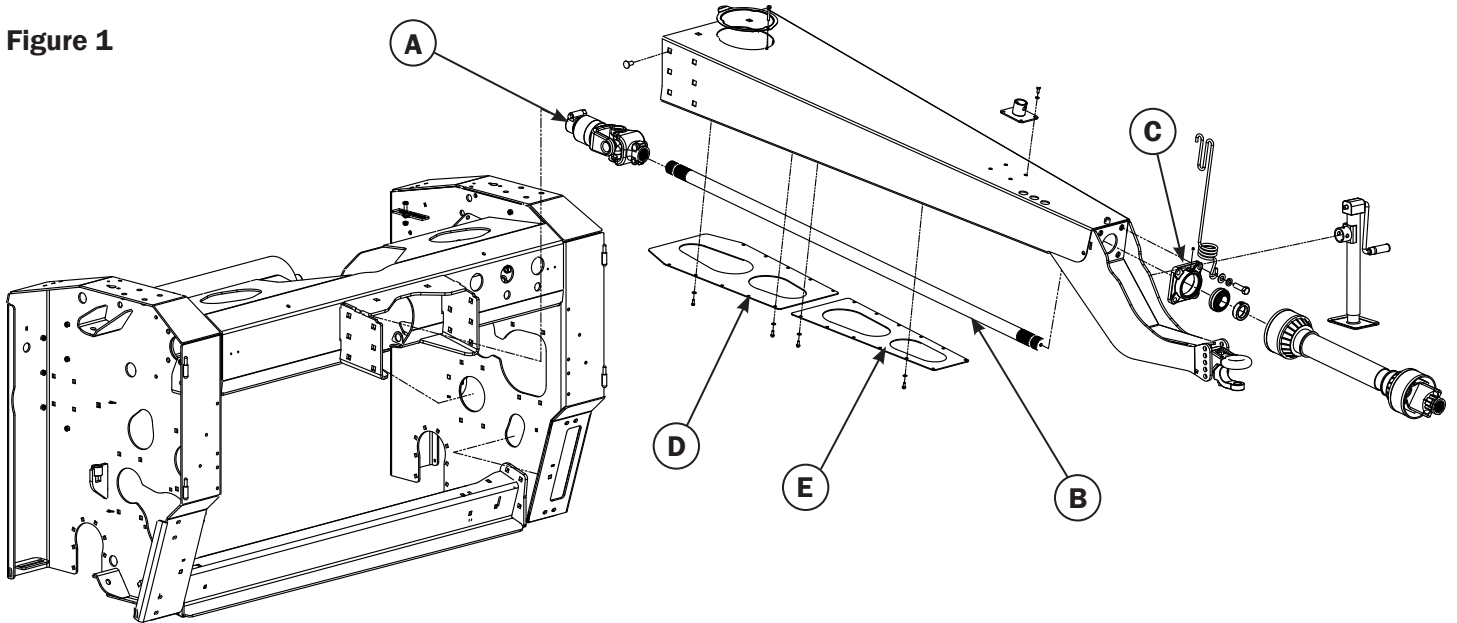
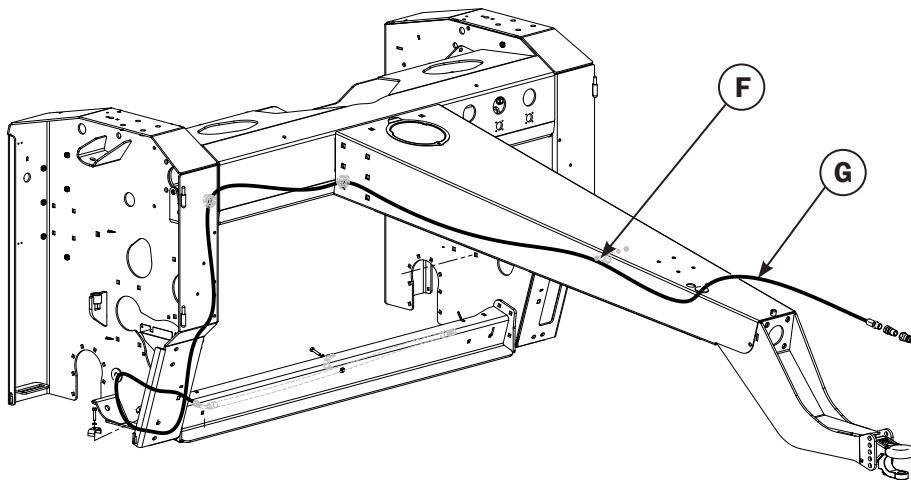

Figure 2



Moldboard Merger

1. Attach left hand (L/H) moldboard attachment bracket (A) to the moldboard main frame (B) and attach main frame to quick attach bracket (C - already installed) and insert lynch pin (O).
2. Attach right hand (R/H) moldboard attachment bracket (E) to the adjustment bar (D) and attach bar to bracket (F - already installed) and insert lynch pin (O).
3. Attach small frame (G) to the main frame (B), using 1/2" x 1-1/2" hex bolts with bushings, washers, lock washers, and hex nuts.
4. Attach extension adjustment bar (H) to small frame (G) using 1/2" x 1-1/2" standard bolt, bushing, washer, lock washer and standard nut and insert adjuster pin (J).
5. Slide main frame adjustment bar (D) through the adjustment bracket (P) and insert 1/2" x 4-1/2" pin (K).

Moldboard Sheet Installation

6. Install short moldboard (L) to outside portion of small frame (G) using 5/16" x 3/4" carriage bolts and hex nuts.
7. Install long moldboard sheet (M) onto the main frame (B) using 5/16" x 3/4" carriage bolts, overlapping the short moldboard sheet.
8. All bolts holding the moldboard sheets can now be fully tightened.
9. Adjust angle of moldboard by moving adjustment bar (D) in or out of adjustment bracket (P) to preferred moldboard angle and insert 1/2" x 4-1/2" pin. A tighter angle will result in less inversion. A wider angle will result in a greater inversion.

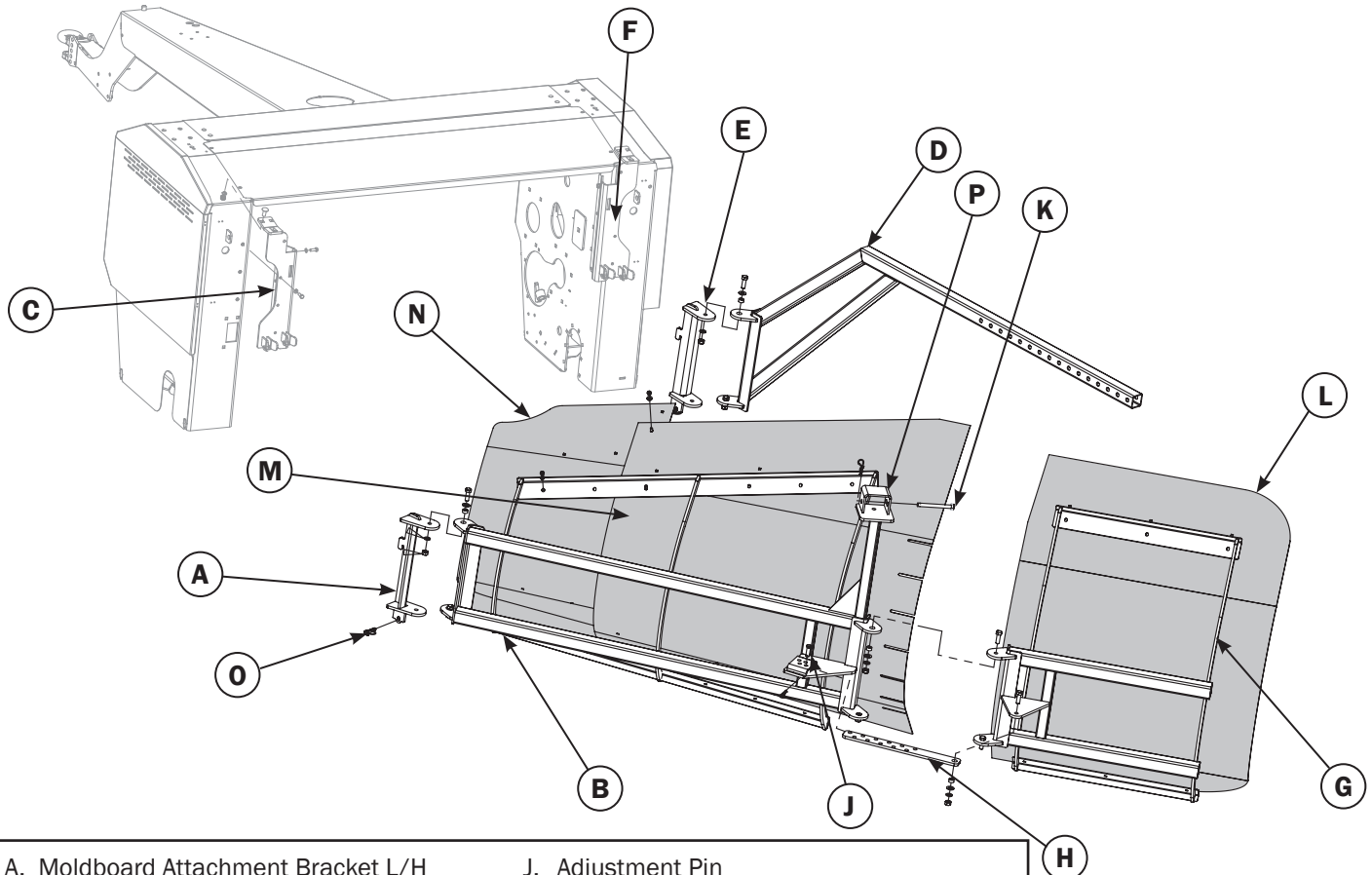

A. Moldboard Attachment Bracket L/H
 B. Moldboard Main Frame
 C. Quick Attach Bracket L/H
 D. Adjustment Bar
 E. Moldboard Attachment Bracket R/H
 F. Quick Attach Bracket R/H
 G. Small Frame
 H. Extension Adjustment Bar

J. Adjustment Pin
 K. Pin
 L. Short Moldboard Sheet
 M. Long Moldboard Sheet
 N. Small Moldboard Sheet
 O. Lynch Pin
 P. Adjustment Bracket

Moldboard Attachment

Assembly (Attachments)

Spreader Attachment

The spreader attachment allows the Macerator to spread a wider swath and leave a thinner layer on the field for greater sun and wind exposure.

The spreader attachment attaches to the rear of the main frame.

1. Attach bracket (A) to the side panels (C and D) using 3/8" x 1-1/4" bolts with washers, lock washers, and nuts.
2. Mount side panels (C and D) to top plate (B) with 5/16" x 3/4" bolts, washers, and lock washers.
3. Assemble reinforcement plates and brackets (K) with hardware bolts, nuts and washers (L).

4. Mount deflector fins (F) to top plate (B) using 3/8" x 3/4" bolts (G) and washers, lock washers, and nuts (H).
5. Hook spreader attachment to the quick mounting brackets (E - on main frame) and insert lynch pin (J).

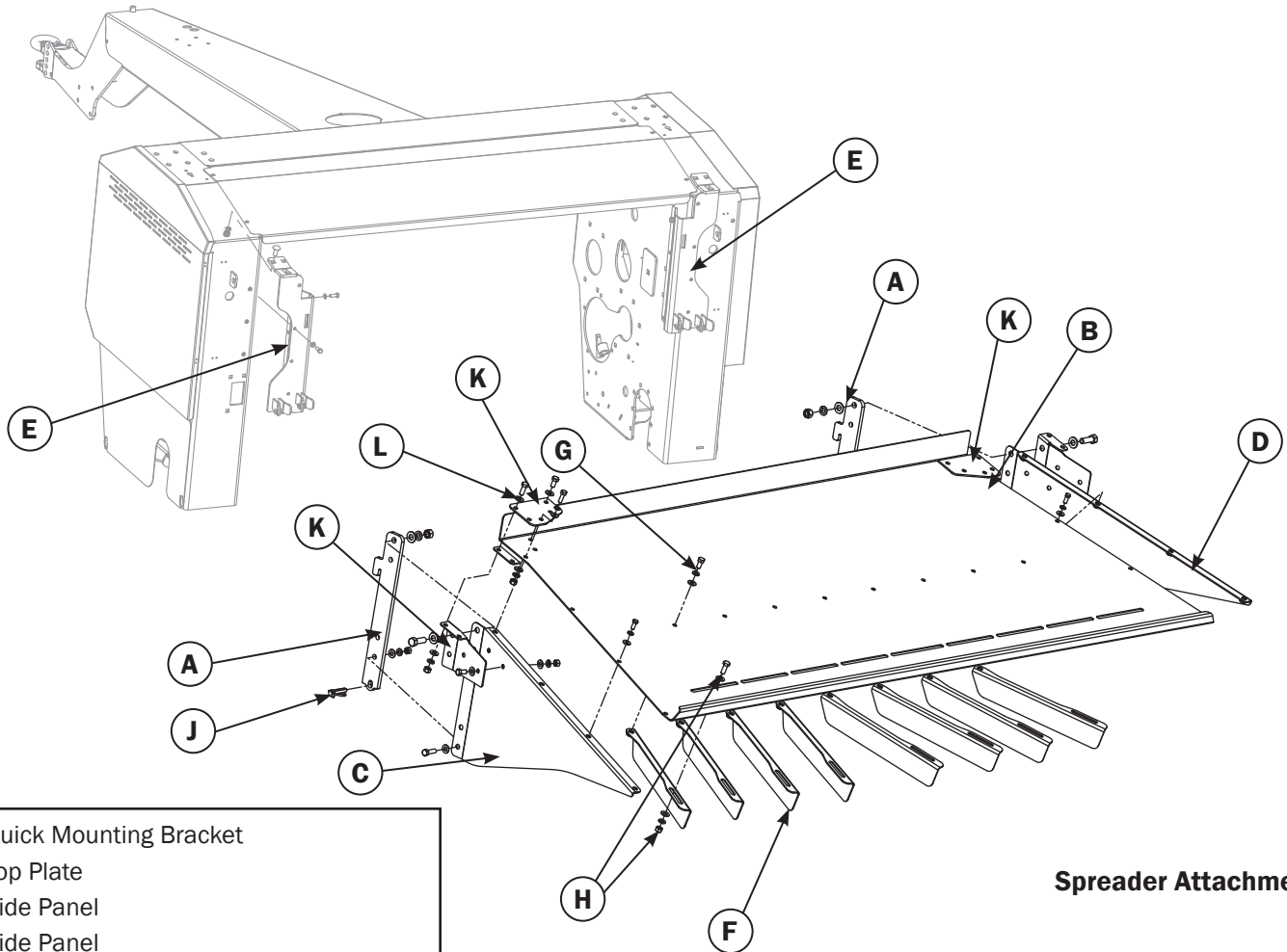

Spreader Attachment

- A. Quick Mounting Bracket
- B. Top Plate
- C. Side Panel
- D. Side Panel
- E. Quick Mounting Bracket (on main frame)
- F. Deflector Fin
- G. Bolt
- H. Nuts and Washers
- J. Lynch Pins
- K. Reinforcement Plates and Brackets
- L. Bolt, Nut and Washer

Windrower Attachment

The windrower attachment allows you to direct the cut hay down to keep a tighter narrow windrow, or up for a wider swath width.

1. Insert 3/8" x 1-1/4" bolts through side panel (A and K) and attach quick mounting bracket (B) to both side panels.
2. Mount side panels (A and K) to top plate (G) with 5/16" x 3/4" bolts. Do not tighten bolts.
3. Assemble reinforcement plates (O) with hardware bolts, nuts and washers (P).
4. Mount side bracket (C) to panel (A) with 3/8" x 3/4" bolts. Only two bolts.
5. Insert windrow baffle (E) into hole of side bracket (C).
6. Mount the other side bracket (F) to side panel (K) with 3/8" x 3/4" bolts.
7. Mount adjustment bracket (H) using 5/16" x 1-1/2" socket head cap screws and wing bolts (D).
8. Install left and right side width adjusters (J and M) using 3/8" x 1" bolt and bushing (L) through top plate (G).
9. Insert wing bolt (D) with washer through slot into width adjusters (J and M).
10. Tighten all bolts evenly.
11. Hook spreader attachment to the quick mounting bracket on main frame and insert lynch pin (N).

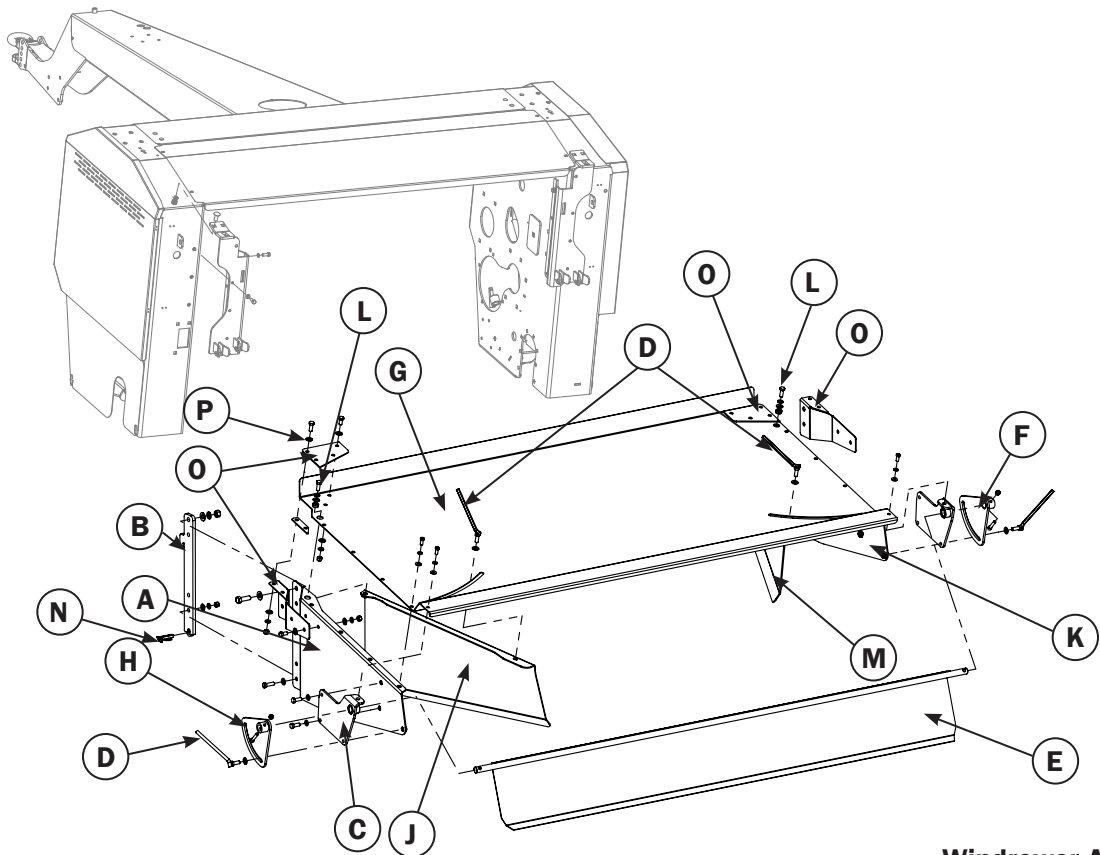

- | | |
|---------------------------|-------------------------|
| A. Side Panel | J. Width Adjuster |
| B. Quick Mounting Bracket | K. Side Panel |
| C. Left Side Bracket | L. Bushing |
| D. Wing Bolt | M. Width Adjuster |
| E. Windrow Baffle | N. Lynch Pin |
| F. Right Side Bracket | O. Reinforcement Plates |
| G. Top Plate | P. Bolt, Nut and Washer |
| H. Adjustment Bracket | |

Windrower Attachment

Note:
Use supplied washers and nuts with described bolts above.

Assembly (Attachments)

Tedder Attachment

| Item No. | Stock No. | Description | Qty. |
|----------|-----------|-----------------------------------|------|
| 1 | 800165 | Bolt, Standard, NC, 1/2" x 1-1/2" | 20 |
| 2 | 800166 | Bolt, Standard, NC, 1/2" x 1-1/4" | 4 |
| 3 | 800167 | Bolt, Standard, NC, 1/2" x 1-3/4" | 8 |
| 4 | 800190 | Bolt, Standard, NC, 3/4" x 2" | 4 |
| 5 | 800191 | Bolt, Standard, NC, 3/4" x 2-1/2" | 1 |
| 6 | 800233 | Nut, Standard, NC, 1/4" | 10 |

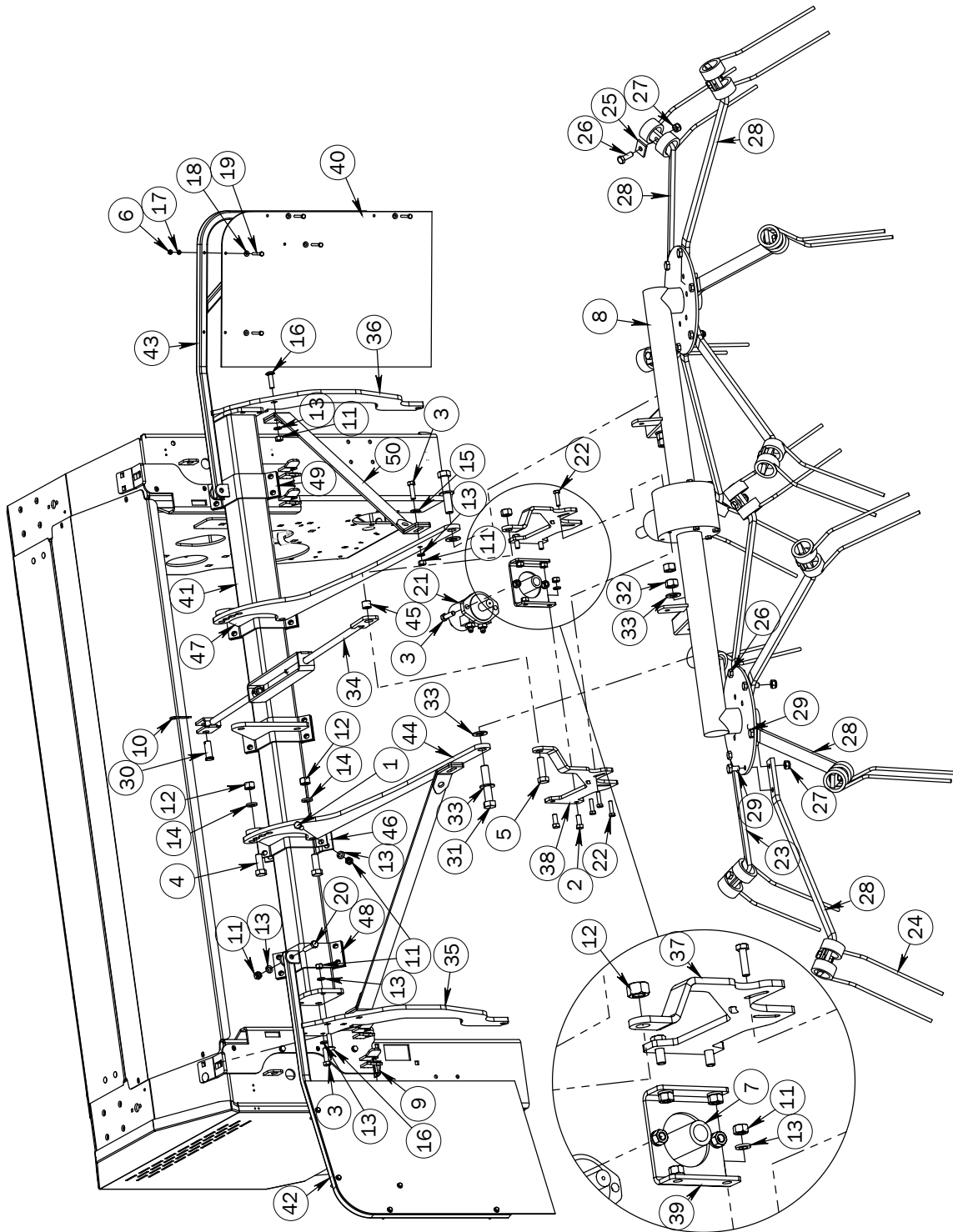

Tedder Attachment

| Item No. | Stock No. | Description | Qty. |
|----------|-----------|---|------|
| 7 | 800321 | Coupler, 1-3/8" | 1 |
| 8 | 801682 | Tedder, Daros (Rossi) | 1 |
| 9 | 801818 | Pin, Lynch, 7/16" | 2 |
| 10 | 801820 | Pin, Hitch, R, 1/8" x 2-5/8" | 1 |
| 11 | 804196 | Nut, Standard, NC, 1/2" | 36 |
| 12 | 804199 | Nut, Standard, NC, 3/4" | 5 |
| 13 | 804367 | Washer, Lock, Spring, 1/2" Gr. 8 | 40 |
| 14 | 804369 | Washer, Lock, 3/4" | 4 |
| 15 | 807524 | Washer, SAE, 1/2" | 2 |
| 16 | 807706 | Bolt, Carriage, NC, 1/2" x 1-3/4" | 6 |
| 17 | 808353 | Washer, Lock, Spring, 1/4" Gr. 8 | 10 |
| 18 | 808781 | Washer, Flat, 1/4" SAE | 10 |
| 19 | 808782 | Bolt, Standard, NC, 1/4" x 2" | 10 |
| 20 | 808784 | Bolt, Standard, NC, 1/2" x 2-1/4" Gr. 8 | 2 |
| 21 | 808785 | Motor, Hydraulic, 2001 DH 50 | 1 |
| 22 | 809040 | Bolt, Standard, Metric, 10 x 1.5 x 40, Gr. 8.8 | 6 |
| 23 | 809090 | Tooth Arm, Fixed, Tedder | 8 |
| 24 | 809091 | Tooth, Tedder | 12 |
| 25 | 809092 | Plate, Tooth Clamp, Tedder | 12 |
| 26 | 809094 | Bolt, Standard, Metric, 14 x 2.0 x 40, Gr. 8.8 | 20 |
| 27 | 809095 | Nut, Standard, Lock, Nylon Insert, Metric, 14 x 2.0 Gr. 8.8 | 24 |
| 28 | 809096 | Tooth Arm, Adjustable, Tedder | 4 |
| 29 | 809098 | Bolt, Standard, Metric, 14 x 2.0 x 25, Gr. 8.8 | 4 |
| 30 | 809586 | Pin, Clevis, 3/4" x 2" | 1 |
| 31 | 812755 | Bolt, Standard, NC, 7/8" x 4-1/2" | 2 |
| 32 | 812756 | Nut, Standard, NC, 7/8" | 4 |
| 33 | 812757 | Washer, SAE, 7/8" | 6 |
| 34 | 810158 | Turnbuckle Assembly, Tedder | 1 |
| 35 | 810553 | Hook, Attachment, L/H, Tedder | 1 |
| 36 | 810555 | Hook, Attachment, R/H, Tedder | 1 |
| 37 | 807861 | Arm, Motor Mounting, R/H | 1 |
| 38 | 807864 | Arm, Motor Mounting, L/H | 1 |
| 39 | 807859 | Motor Mounting Plate | 1 |
| 40 | 807882 | Tedder Flap | 2 |
| 41 | 807876 | Tedder Main Beam | 1 |
| 42 | 810559 | Tedder Flap Frame, L/H | 1 |
| 43 | 810562 | Tedder Flap Frame, R/H | 1 |
| 44 | 810557 | Arm, Tedder | 2 |
| 45 | 810157 | Bushing, Turnbuckle, Tedder | 1 |
| 46 | 813960 | Clamp, Tedder | 5 |
| 47 | 813968 | Bracket, Attachment, Tedder | 3 |
| 48 | 813970 | Clamp, Bracket, Flap Attach, L/H, Tedder | 1 |
| 49 | 813972 | Clamp, Bracket, Flap Attach, R/H, Tedder | 1 |
| 50 | 814677 | Stabilizer Bar, Tedder | 2 |

Assembly (Attachments)

Tedder Attachment Hydraulics

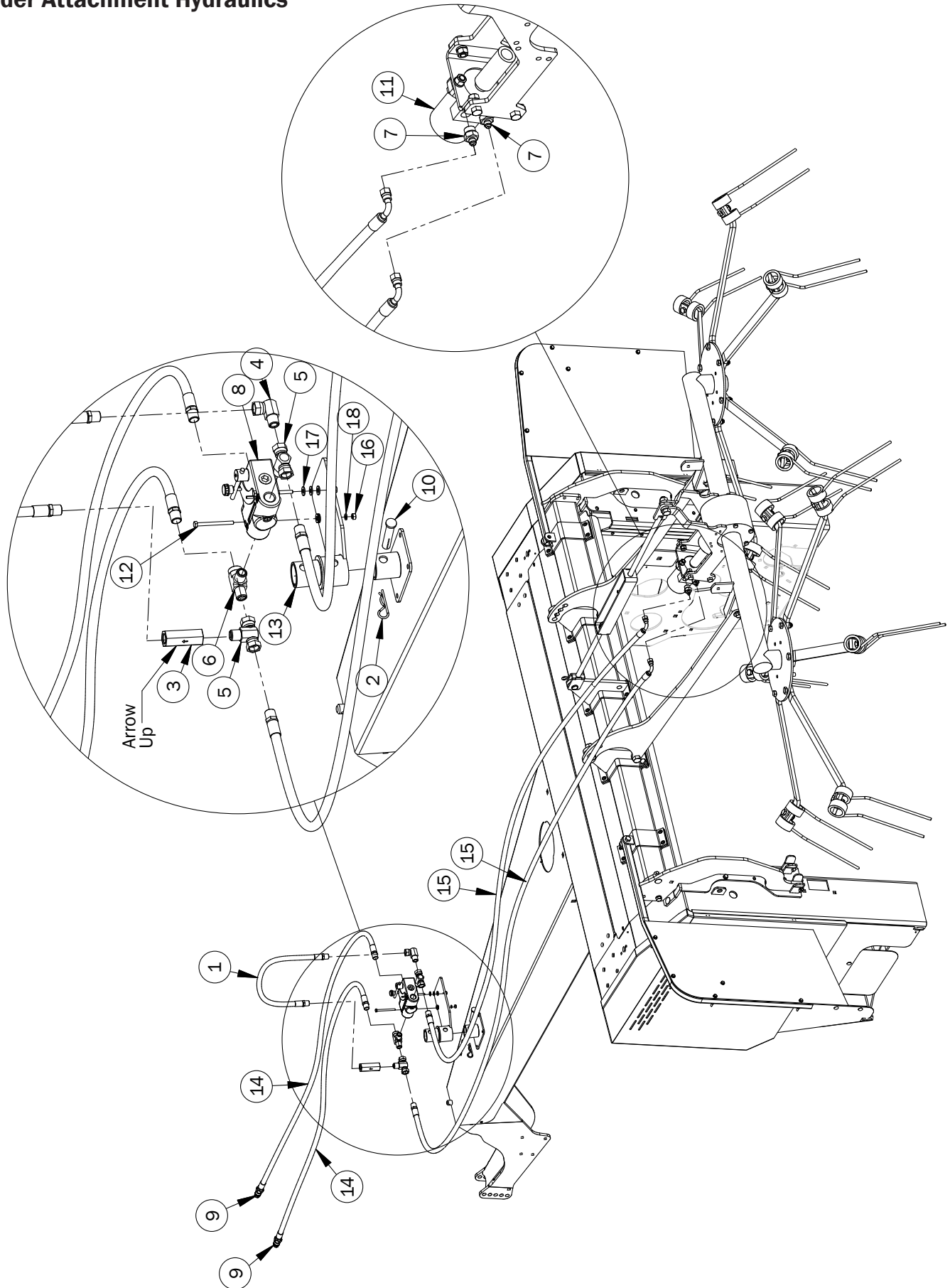

Tedder Attachment Hydraulics

| Item No. | Stock No. | Description | Qty. |
|-----------------|------------------|------------------------------|-------------|
| 1 | 802478 | Hydraulic Hose, 24" | 1 |
| 2 | 801820 | Pin, R, 1/8" | 1 |
| 3 | 802474 | Valve, Check | 1 |
| 4 | 802482 | Elbow, Hydraulic | 1 |
| 5 | 802484 | Tee, Hydraulic | 2 |
| 6 | 802485 | Tee, Hydraulic | 1 |
| 7 | 802486 | Adapter, Hydraulic | 2 |
| 8 | 802836 | Valve Body | 1 |
| 9 | 804099 | Quick Coupler | 2 |
| 10 | 807055 | Pin, Clevis | 1 |
| 11 | 808785 | Motor, Hydraulic, 2001 DH 50 | 1 |
| 12 | 808783 | 1/4" x 3" Bolt, Standard | 2 |
| 13 | 807879 | Valve Body Holder | 1 |
| 14 | 808721 | Hydraulic Hose | 2 |
| 15 | 808722 | Hydraulic Hose | 2 |
| 16 | 800233 | 1/4" Nut, Standard | 2 |
| 17 | 807522 | 5/16" SAE Washer, Flat | 6 |
| 18 | 808353 | 1/4" Washer, Lock | 2 |

Field Set Up

Use with a tractor having a minimum of 80 HP (60 kW). Tractor should have sufficient ground clearance for swath to pass cleanly under it.

PTO Speed

Unless otherwise specified, units are shipped with 1000 PTO speed. Units with 540 RPM PTO are also available. Contact your dealer for more information.

The PTO should be run at approximately 1000 RPM. The front rubber rolls run at 645 RPM and the bottom steel roll runs at 1514 RPM at a tractor PTO speed of 1000. The upper steel roll runs at 1372 RPM at 1000 tractor PTO speed.

Pickup Height & Adjustment

The Macerator 6620 pickup should be adjusted so that it will cleanly pick up all material off of the field without gouging the soil. The height may need resetting in order to arrive at the best working height.

1. If the pickup is too low to the ground use the tractor hydraulic cylinder control to raise the pickup.
2. Remove pin (A) and slide adjuster bar (B) to desired height. Pushing bar in raises machine, and pulling the bar out lowers the machine.
3. Reinsert pin and lock in place.

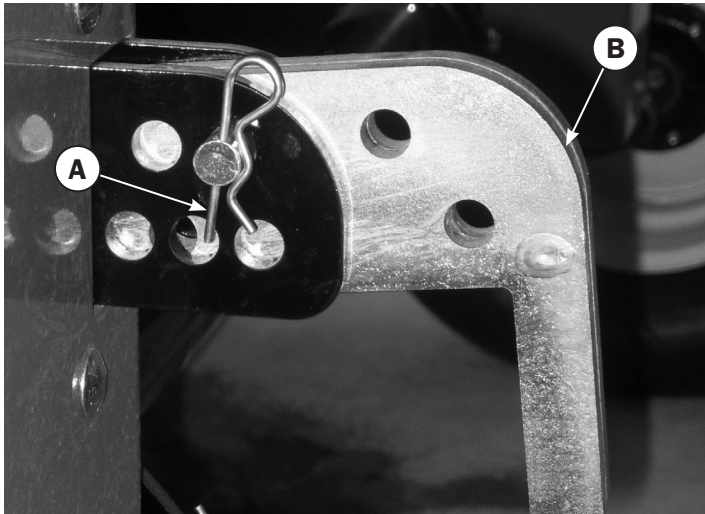

Steel Roll Adjustment

For best results adjust the Macerator 6620 for your specific field conditions. The smaller the gap between the steel serrated rolls, the more aggressive the maceration of the hay will be. Both the space between the rolls and the air pressure need to be adjusted for maximum efficiency.

1. Raise the Macerator using the hydraulics.
2. Turn crank (A) clockwise to widen the gap or counter-clockwise to narrow the gap. 1/2 turn = .02" (0.5 mm). For a better fine tune, adjust bolt (D).
3. Ensure to set the gap exactly the same on both sides, using a gauge.

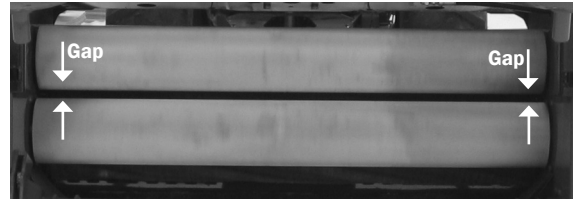

4. Put crank lock (B) in place and secure with pin (C).
5. To ensure that the rolls do not touch, the safety stop is set by the factory at 1/32" or .8 mm.
6. If the safety stop (E) needs adjusting put the travel pin (F) in place while unit is raised.
7. Adjust the safety stop bolt (E) as needed. Ensure the rolls do not touch during operation.
8. Repeat steps 1-7 to fine tune if necessary.

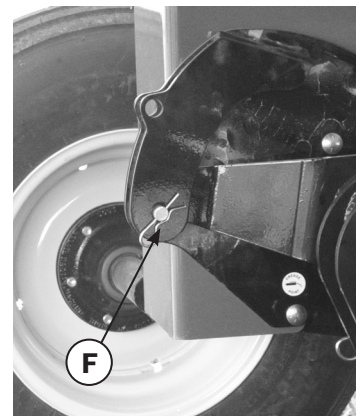
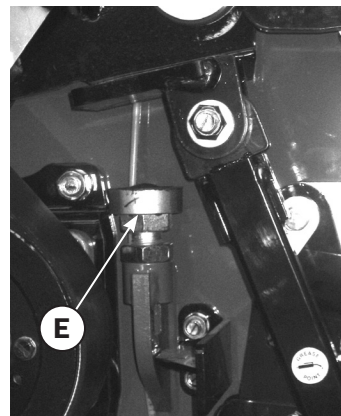
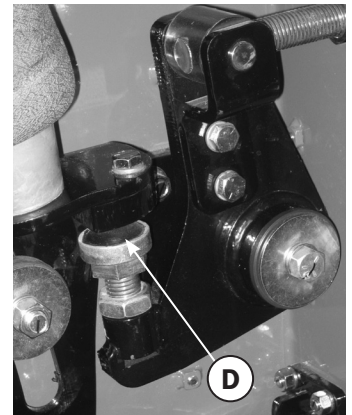
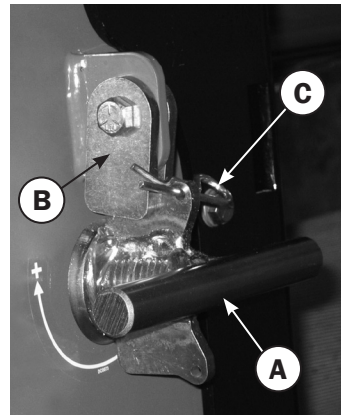

Preparation (Air System)

The purpose of the air system on the Macerator 6620 is to keep continuous pressure on the rolls.

The pressure can make a difference on how well the machine performs on the field. While the pressure on the rubber rolls may not be as crucial, too much pressure on the steel rolls will result in considerable leaf loss and some plugging may result in short wet hay.

Before heading out to the field, ensure the air pressure tank has a minimum of 100 PSI (689 kPa) pressure. Not to exceed 120 PSI (827 kPa). This should give the operator sufficient air supply for the day.



3. If there is too much leaf loss or the plants are crushed too intensely, lower the air pressure.
4. If there is not enough maceration, increase pressure to the rolls by increasing the air pressure. Ensure the gap is adjusted as per the attached table.

Note: *Steel Roll Pressure should not be set higher than 65 PSI (448 kPa) at any time during field operation.*

Rubber Roll Pressure Adjustment

The rubber rolls are designed to take the material from the pickup and feed it into the steel rolls. The rubber rolls do not crush or crimp the hay.

As a standard setting, we recommend 20–30 PSI (138 - 207 kPa) pressure on the rubber rolls. Regulate the pressure by pulling out the knob on the regulator marked 'rubber rolls' and turning it clockwise or counter-clockwise. When turning the knob counter-clockwise the sound of air escaping from the regulator should be heard.

In extreme conditions, increase or decrease the pressure. For example, very heavy swaths may require more pressure.



Figure 1

Steel Roll Pressure Adjustment

The steel serrated rolls (rear) take the material from the rubber rolls and crack the stems. To achieve the right setting, some field testing may be necessary. (Trial and error.)

1. Pull out the knob on the air regulator marked 'steel rolls' and turn the knob clockwise or counter-clockwise to set the pressure to the steel rolls as per the attached table.
2. On 2008 Macerators, lower the Steel Roll Air Pressure by pulling the Relief Valve Ring at top of Left Side Air Bag (Fig. 1) to relieve pressurized air. (Ensure the Pressure Valve Knob is pulled out and turned all the way counter-clockwise before relieving air from the bag.) Repeat pressure setting as in step 1 above to set a new air pressure.



Initial Field Settings

Initial Recommended Roll Settings (Starting Point)

| Crop Types | Steel Roll Gap | Steel Roll PSI (kPa) | Rubber Roll Gap | Rubber Roll PSI (kPa) |
|-------------------------------------|------------------------------|----------------------|-----------------|-----------------------|
| Timothy/Grasses | 1/32" (0.8mm) | 60 (414) | 1/32" (0.8mm) | 50 (345) |
| Bermuda/Brougham Grasses | 1/32" (0.8mm) | 60 (414) | 1/32" (0.8mm) | 50 (345) |
| Cereals, Oat Hay/Wheat | 1/32" (0.8mm) | 50 (345) | 1/32" (0.8mm) | 50 (345) |
| 1st Cut Alfalfa | 1/8" (3.2mm) | 5 (34) | 1/32" (0.8mm) | 20 (138) |
| 2nd, 3rd, 4th Cut Alfalfa | 3/16" (4.8mm) - 1/4" (6.4mm) | 5-7 (34-48) | 1/32" (0.8mm) | 15-20 (103-138) |
| Broad Leaf and Heavy Stemmed Plants | 1/4" (6.4mm) | 60 (414) | 1/32" (0.8mm) | 50 (345) |

Checklist

CAUTION

Use Good Safety Practices When Working On This Machine

Before doing any maintenance or service on the machine you must:

- Park machine on a solid level surface.
- Lower the machine fully to the ground or onto blocks.
- Disengage all power.
- Put the tractor transmission in PARK or apply the tractor parking brake.
- Stop the tractor engine and remove key from the ignition.
- Look and listen. Make sure all moving parts have stopped.

First Time Use

- Tighten hub bolts A-E* after the first one (1) hour of operation and repeat procedure after ten (10) hours and fifty (50) hours.

***Important**

Hubs A - tighten to 60 ft-lbs

Hubs B - tighten to 30 ft-lbs

Hubs C - tighten to 9 ft-lbs

Hubs D - tighten to 6 ft-lbs

Hub E - tighten to 15 ft-lbs

Daily

- Check and tighten all hub bolts.
- Remove all dirt and crop deposits from machine.

After The First Twenty-Five (25) Hours Of Use

- Check bearing and set screw tightness.

At The Beginning Of Each Season

- Review all safety instructions.
- Carefully inspect all components for excessive wear or hazardous conditions.
- Lubricate the machine at all lubrication points.*
- Check tires for correct inflation pressure.
- Tighten bolts.

**See lubrication schedule and procedures on page 24.*

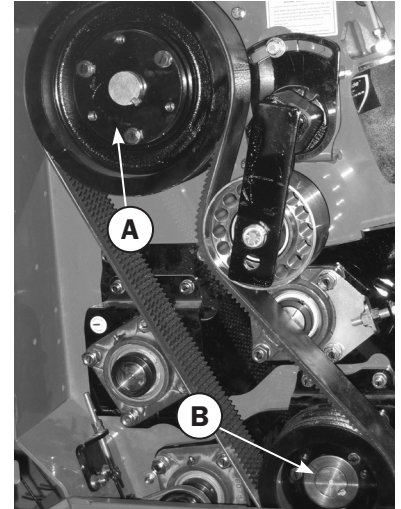
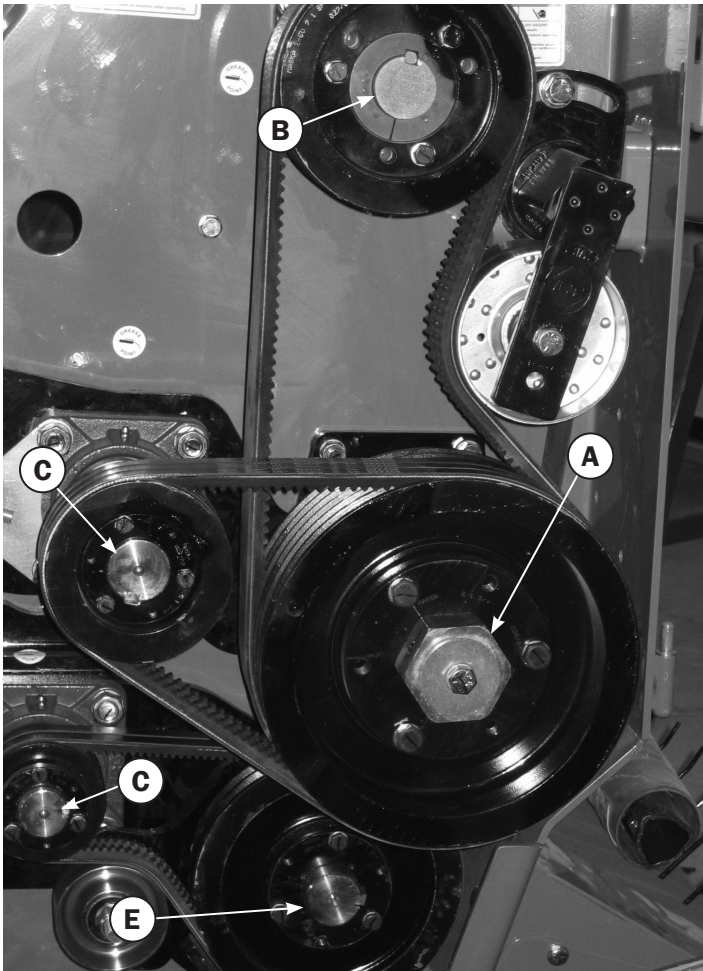

Roll Drive Belt Replacement

Replace worn or damaged belts as follows:

1. Raise Macerator and secure travel safety pin, see page 6.
2. To remove belts (A) loosen and turn flattened bolt (B) counter-clockwise.
3. To remove belts (C) loosen 4 bolts (D), then loosen bolt (E) and slide roll forward.*
4. To remove belt (F) loosen bolt (G) behind tightener, then loosen bolt (H) and slide tightener forward.
5. To remove belt (M) loosen bolt (N) on the other side of the panel behind tightener. Take tightening wrench (O) (use a pipe for leverage) and hold spring loaded tightener (P) firmly in place while loosening bolt (Q), then release tension slowly with wrench.
6. Replace all belts and tighten bolts (reverse sequence of steps 2-5).
7. To remove belt (J) loosen spring tension by turning off nut (K) counter-clockwise. To tighten the belt, tighten nuts (K) until you measure approximately 1-1/2 inches (3.8cm) (L) or proper tension on the belt, see drawing below.
8. Reinstall all covers.

* To maintain proper roll alignment be sure to adjust the opposite tightener on the other side of the machine.

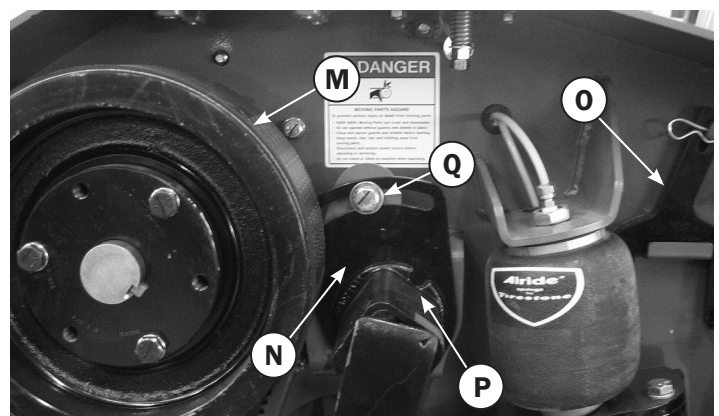
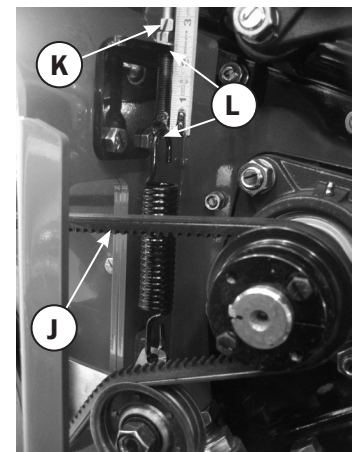
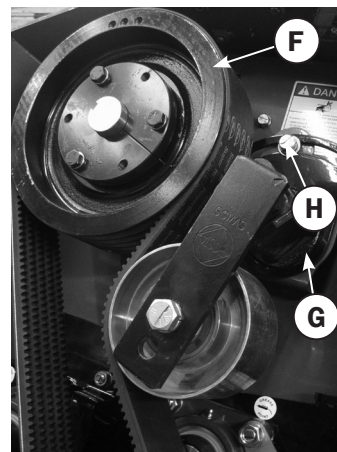
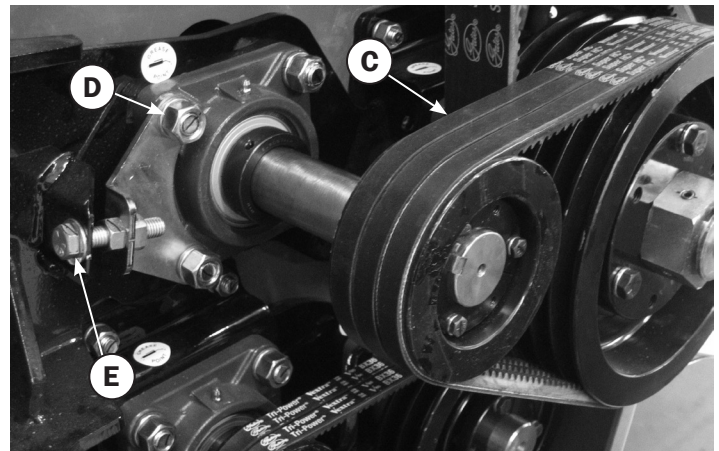
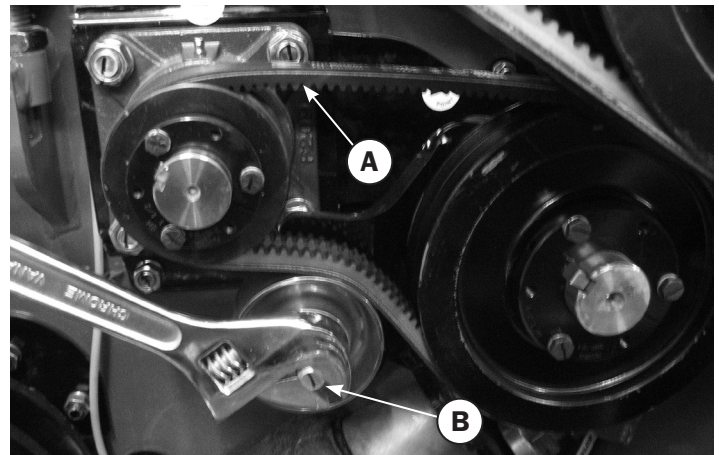
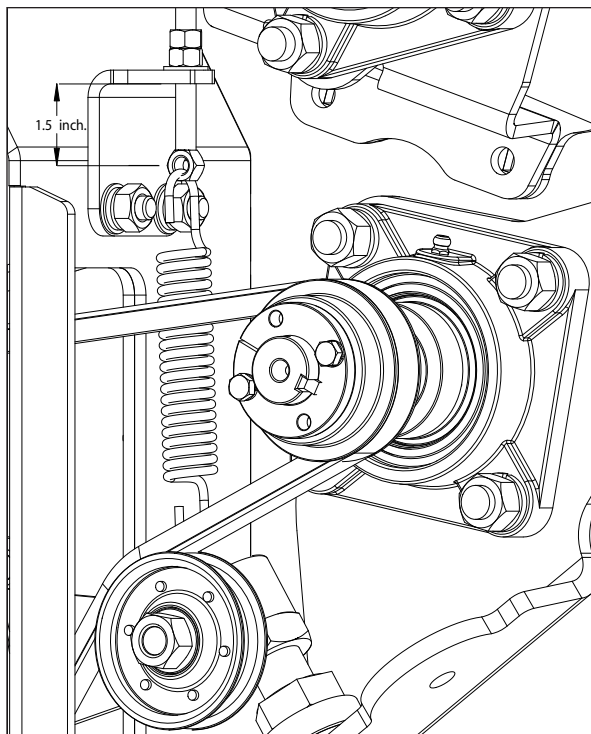

Bearing Replacement

Sealed ball bearings are held in position on the shaft by a locking collar, Figure 1, which is rotated to lock the assembly on the shaft and secured by a set screw. To remove bearing:

1. Loosen set screw.
2. Use a drift punch inserted in the drift pin hole to rotate and loosen the locking collar (A). Rotate the locking collar counter-shaft rotation.
3. Remove the locking collar.
4. Support the shaft, for easier assembly later.
5. Remove the bolts for the bearing flanges.
6. Slide the bearing and the flanges from the shaft. Note: Cleaning paint and corrosion from the shaft will make removal easier.
7. Put on the new bearing and flanges.
8. Replace locking collar on the shaft. Rotate the locking collar in the direction of the shaft rotation until lightly engaged. Tighten the collar by hitting it with a drift pin punch inserted in the drift pin hole rotating it further until fully tightened.
9. Tighten set screw.

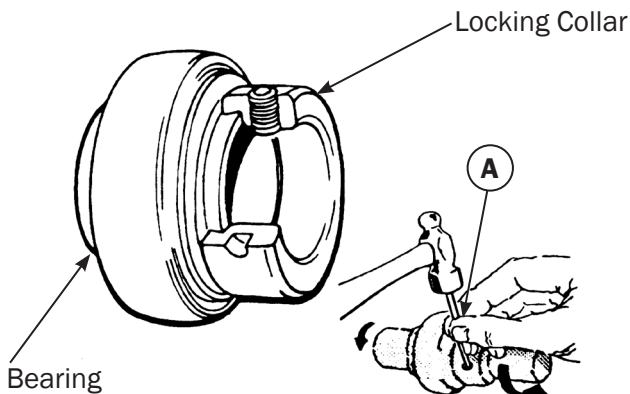

Figure 1

Replacing or Repacking Wheel Bearings

1. Remove wheel hubs and disassemble.
2. Clean bearings, seals, caps, washers, nuts, and hubs with kerosene or other solvent.
3. Replace bearings or seals if worn or damaged.
4. Pack bearing cones and seals with No. 2 multipurpose lithium grease or equivalent.
5. Reassemble hub and bearings, Figure 2.
6. Press cups (race) against the shoulder in the hub.

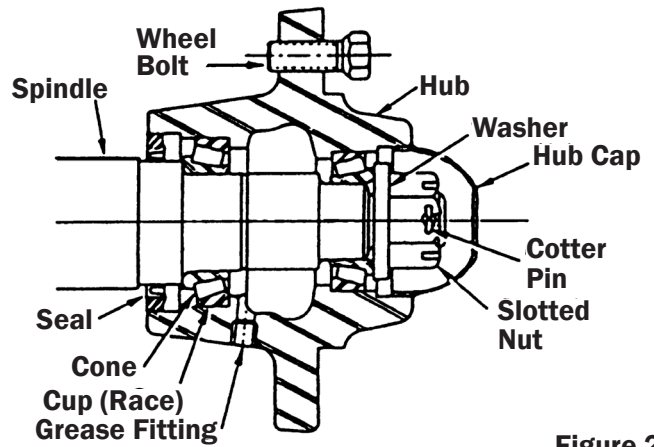

Figure 2

1. Press seal flush into hub after bearing.
2. Place hub on shaft taking care not to damage the seal.
3. Tighten the wheel bearing nut. Do not overtighten.
4. Secure nut with a cotter pin.
5. Be sure to replace hub cap.

Pickup Teeth, Wrappers, and Wear Strips

Check for bent, broken or loose parts. If it is necessary to replace teeth or related parts, proceed as follows.

1. Ensure that the Macerator is blocked securely. Loosen the bolt holding the wrapper(s) on the pickup, Figure 3. Lift the wrapper on top, tilt and slide forward to remove, Figure 4.
2. Should the plastic wear strip require removal and replacement, drill out or carefully grind off the 'pop' rivets. Replace strip with new rivets, Figure 5.
3. Install new teeth or wrapper(s).



Figure 3



Figure 4

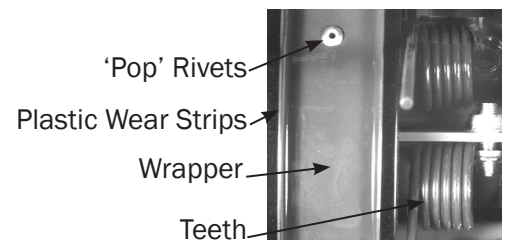

Figure 5

Inch Torque Chart for Bolts and Nuts

Standard Torque Requirements Foot-Pounds
Use this chart as a guide when tightening bolts/nuts which do not have special torque requirements.

| Bolt Diameter (inches) | Bolts | | Locknuts | |
|------------------------|---------------------------|---------------------------|-----------------------|-----------------------|
| | SAE Grade 5 Plated W/ZnCr | SAE Grade 8 Plated W/ZnCr | Grade B with GR5 Bolt | Grade C with GR8 Bolt |
| 1/4 | 112* | 157* | 61* | 86* |
| 5/16 | 229* | 324* | 125* | 176* |
| 3/8 | 34 | 48 | 19 | 26 |
| 7/16 | 54 | 77 | 30 | 42 |
| 1/2 | 83 | 117 | 45 | 64 |
| 9/16 | 120 | 169 | 65 | 92 |
| 5/8 | 165 | 233 | 90 | 127 |
| 3/4 | 293 | 413 | 160 | 226 |
| 7/8 | 473 | 667 | 258 | 364 |
| 1 | 708 | 1000 | 386 | 545 |



SAE Grade 5



SAE Grade 8



*Torque values are inch-pounds.

Note: For inch and metric bolts and nuts:

- These values are based on clean, dry threads. Reduce the value by 10% when a lubricant is used. Reduce the value by 20% if new plated bolts are used.
- Bolts threaded into aluminum must have two diameters of thread engagement and may require 30% more reduction in the torque.

Metric Torque Chart for Bolts and Nuts

Standard Torque Requirements Foot-Pounds
Use this chart as a guide when tightening bolts/nuts which do not have special torque requirements.

Metric Bolt Markings & Torque Values

Metric bolts are identified by the grade number stamped on the head of the bolt or on the surface of metric nuts. The higher the number, the greater the strength of the bolt.

| Bolt Diameter | Grade 8.8 | Grade 10.9 |
|---------------|-----------|------------|
| 6mm | 60* | 108* |
| 7mm | 108* | 168* |
| 8mm | 18 | 23 |
| 10mm | 30 | 45 |
| 12mm | 55 | 75 |
| 14mm | 85 | 120 |
| 16mm | 130 | 175 |
| 18mm | 170 | 240 |



8.8



10.9

*Torque values are inch-pounds.

Lubrication

General Information

A NLGI No. 2 multi-purpose high temperature lithium base grease is recommended.

Use a manual grease gun for all greasing. Air powered grease guns may damage the seal on the bearings.

Wipe all grease fittings with a clean cloth before greasing to avoid injecting dirt or grit in the bearings.

At The Beginning Of The Season

Grease all sealed bearings, front rolls (two places), rear rolls (two places) and drive shaft (one place) one shot, Figures 1 and 2.

Thereafter, grease all sealed bearings and universal joints weekly or every fifty (50) hours. Bushings and axle bushings daily or every ten (10) hours.

It is recommended that the steel roll bearings be changed every 3000 acres or yearly.

It is also recommended that the pickup cam follower bearings be changed on a yearly basis.

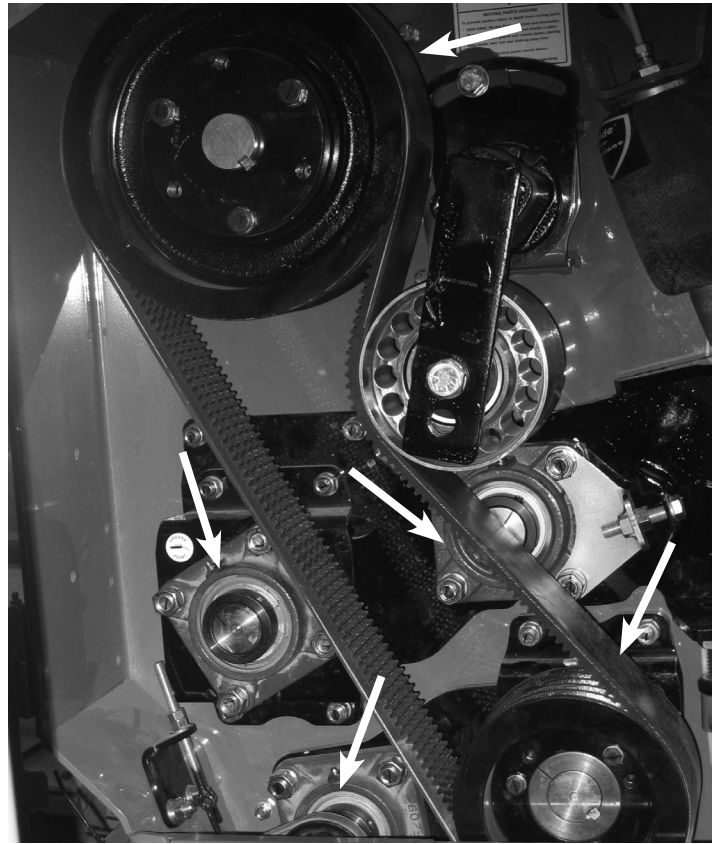

Figure 1

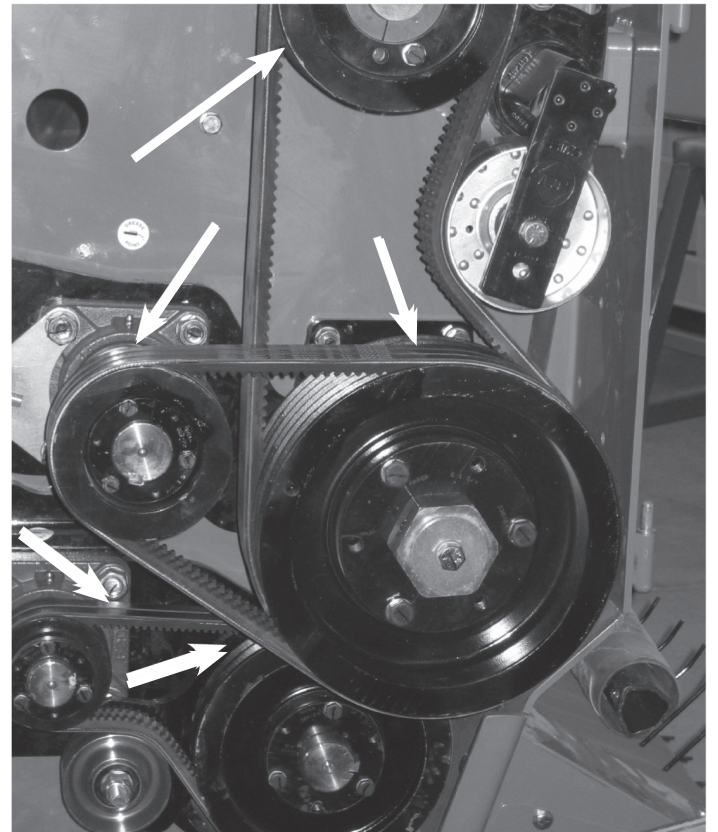
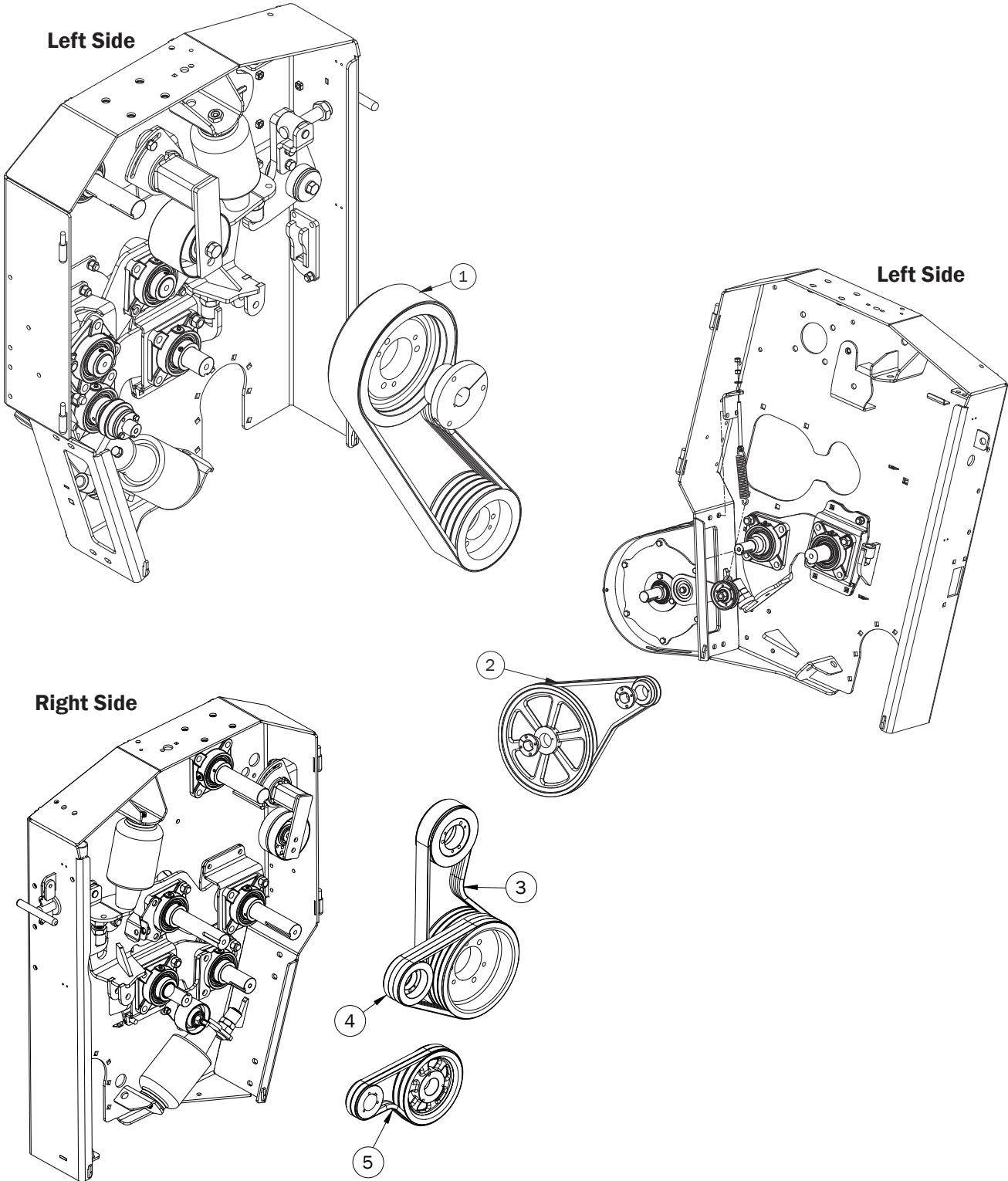

Figure 2

| Reference | Part Number | Description | Drive | Qty. |
|-----------|-------------|-------------|--------------------|------|
| 1 | 806943 | 5-5VX800 | Bottom Steel Roll | 1 |
| 2 | 802922 | BX-54 | Pickup | 1 |
| 3 | 806942 | 3-5VX630 | Top Rubber Roll | 1 |
| 4 | 802911 | 5VX450 | Top Steel Roll | 3 |
| 5 | 802917 | BX-36 | Bottom Rubber Roll | 2 |



Optional Kits

The following is a list of the Optional Kits for the Macerator, please contact your Dealer for availability and pricing.

| Kit Number | Description |
|------------|---|
| K107 | Gathering Wheels Kit |
| K6005 | Tooth Clamp Kit |
| K6008 | Alfalfa Roll Speed Kit |
| K6009 | Air Regulator Kit |
| K6010 | Hitch Clevis Kit |
| K6012 | Windrower Reinforcement Kit |
| K6016 | Bottom Rubber Roll Adjustment Bracket Revision, L/H and R/H |

| Problem | Possible Cause | Solution |
|--|---|--|
| Pickup is skipping swath or not picking cleanly. | <ul style="list-style-type: none"> ▪ Missing or broken pickup teeth. ▪ Pickup too high. ▪ Driving too fast for pickup speed. ▪ Not following the same direction as swath was cut. | <ul style="list-style-type: none"> ▪ Replace missing teeth. ▪ Adjust pickup height. ▪ Use lower tractor gear with higher RPM. ▪ Follow same direction as swath cut. |
| Material wrapping in pickup. | <ul style="list-style-type: none"> ▪ Pickup running too low. ▪ Pickup and travel speeds are not matched. | <ul style="list-style-type: none"> ▪ Set pickup teeth 1" to 2" above ground. ▪ Match pickup and ground speed as close as possible. |
| Breakage or bending of pickup teeth. | <ul style="list-style-type: none"> ▪ Running pickup too low. ▪ Excessive pickup rotation speed in rough or rocky conditions. | <ul style="list-style-type: none"> ▪ Adjust pickup height. ▪ Reduce pickup or ground speed. |
| Excessive noise or heat from gear box. | <ul style="list-style-type: none"> ▪ Insufficient oil in gear box. ▪ Worn or broken parts inside gear box. | <ul style="list-style-type: none"> ▪ Top up gear oil as needed. ▪ Replace parts as needed. |
| Air pressure does not hold in air tank and air bags. | <ul style="list-style-type: none"> ▪ Broken air line. ▪ Torn or punctured air bag. ▪ Air regulator not working. | <ul style="list-style-type: none"> ▪ Repair or replace line as needed. ▪ Replace air bag as needed. ▪ Clean or replace regulator. |
| Pickup does not rise or lower. | <ul style="list-style-type: none"> ▪ Worn or punctured hydraulic cylinder or hydraulic oil line. ▪ Bushings too tight. | <ul style="list-style-type: none"> ▪ Replace hydraulic lines and cylinders as needed. ▪ Replace or clean bushings. |
| Pickup height adjustment does not hold. | <ul style="list-style-type: none"> ▪ Broken or worn parts on adjuster. | <ul style="list-style-type: none"> ▪ Replace worn parts as needed. |
| Rubber rolls not feeding properly. | <ul style="list-style-type: none"> ▪ Air pressure too high or low. ▪ Gap between rolls too tight or too wide. | <ul style="list-style-type: none"> ▪ Adjust air pressure using regulator. ▪ Adjust gap width. |
| Wax buildup on steel rolls. | <ul style="list-style-type: none"> ▪ Temperature and hay conditions cause the wax to come off of the plant and stick to the rolls. | <ul style="list-style-type: none"> ▪ The wax will come off after the rolls cool down. |
| Excessive leaf loss. | <ul style="list-style-type: none"> ▪ Too much air pressure on steel rolls. ▪ Hay conditions too dry. ▪ The gap between steel rolls is too narrow or the rolls are going too fast. | <ul style="list-style-type: none"> ▪ Release air pressure. ▪ Condition hay early in the morning. ▪ Adjust gap between steel rolls. |
| Hay is not being macerated. | <ul style="list-style-type: none"> ▪ Not enough air pressure on steel rolls. ▪ Gap between rolls is too wide. ▪ Windrow is too thick. ▪ Steel rolls not running fast enough. | <ul style="list-style-type: none"> ▪ Adjust air pressure as required. ▪ Narrow the gap between steel rolls. ▪ Cut wider or thinner windrows. ▪ Increase tractor RPM. |
| Swath not being inverted completely. | <ul style="list-style-type: none"> ▪ Moldboard is not adjusted properly. | <ul style="list-style-type: none"> ▪ Adjust moldboard angle. A tighter angle will result in less inversion. A wider angle will result in a greater inversion. |

LIMITED WARRANTY

AGLAND INDUSTRIES INC. WARRANTY

AgLand Industries Inc. (hereinafter called "AgLand"), as the Manufacturer, warrants to the original owner of the AgLand Macerator (hereinafter called the "Macerator") the following:

A one (1) year* warranty that the purchased Macerator will be free of defects in material or workmanship and workmanship on all parts manufactured by AgLand, including AgLand manufactured owner-serviceable parts (provided such parts are serviced in accordance with the Operator's Manual), from the date of delivery to the original retail purchaser under normal farm use and service, excluding normal wear items such as (but not limited to) belts, pickup tines, tires, and exterior finish.

*Three (3) months after delivery when purchased by a commercial operator.

The sole obligation of the Manufacturer is limited to repairing or replacing, as the Manufacturer may elect, any part or parts that prove, in the Manufacturer's judgement, to be defective in material or workmanship.

Warranty service may only be performed by an authorized AgLand Dealer or an authorized AgLand Service Centre or as determined by AgLand.

Defective parts must be returned to the Manufacturer or the AgLand Dealer who sold the Macerator at the expense of the retail purchaser and are to be inspected by the Manufacturer prior to any warranty work being approved. The AgLand Dealer will forward, at the retail purchaser's expense, any defective parts to AgLand with a written request of warranty work required.

Note: All parts NOT manufactured by AgLand carry their own manufacturer's warranty. The customer is responsible for all costs necessary to replace those parts unless covered by the applicable manufacturer.

The above warranty is based on the following factors:

AgLand reserves the right to repair or replace, at its discretion, any defective part in whole or in part.

All instructions in the AgLand Macerator Operator's Manual must be followed.

The Warranty Registration must be forwarded to AgLand within thirty (30) days of the date of delivery of the Macerator to the Retail Purchaser to validate the warranty.

All warranties are subject to legislation of the state or province in which the Macerator is sold.

AgLand will not be responsible or liable for any of the following:

a) The return of any part or parts, or the Macerator as a whole, to the selling AgLand Dealer or to the Manufacturer, neither AgLand or its authorized AgLand Dealer are responsible for the cost of shipping, transport, or freight, labour, or any cost other than the replacement part itself, if that is what AgLand determines; b) The care, maintenance and safe operation of the Macerator is the responsibility of the owner of the Macerator; c) Any accidents, injury, damage or loss incurred due to use by any operator of the Macerator; d) Any accidents, injury, damage or loss incurred due to faulty use, repair, operation or maintenance of the Macerator; e) Any cost incurred for replacing or repairing of parts not manufactured by AgLand which carry their own manufacturer's warranty; f) Any out-of-pocket expenses or loss of revenue as a result of any defect in material or workmanship of any part or parts, or the Macerator as a whole; g) Damages, malfunctions or failures resulting from the use of any attachment not authorized by AgLand; h) Any accidents, injury, damages, or loss incurred due to any safety shields, lights, reflectors, decals, emblems, etc., being removed or covered; i) Any

accidents, injury, damage or loss due to the improper, or lack of, use of the safety tow chain or transport lock pin during transport; j) Any accidents, injury, damage or loss due to the lack of safety precautions when performing routine maintenance; k) Damages, malfunctions or failures caused by force majeure, abuse, accident, fire, or acts of God; l) All customers outside of North America are responsible for compliance with local laws, codes and regulations regarding operating requirements and certification, as well as all costs associated with such requirements and certification.

Any available warranty will be void if: a) Annual maintenance procedures are not followed as per the Operator's Manual; b) Any altering or modification is performed on the Macerator which is not approved by the Manufacturer; c) Any additional equipment is installed on the Macerator which has not been approved by the Manufacturer; d) Any instruction given in the Operator's Manual which has not been followed including during set up or assembly of attachments, or regular maintenance; or e) Any claim made under this warranty by, or for, a person other than the original owner.

There are no other warranties, expressed or implied, by AgLand or its Authorized AgLand Macerator Dealers regarding the AgLand Macerator except the warranty expressed herein. ANY IMPLIED WARRANTIES, INCLUDING MERCHANTABILITY, OR FITNESS FOR A PARTICULAR PURPOSE, SHALL NOT EXTEND BEYOND THE APPLICABLE WARRANTY PERIODS SPECIFIED ABOVE. AGLAND'S SOLE LIABILITY, WITH RESPECT TO ANY DEFECT, SHALL BE AS SET FORTH IN THIS LIMITED WARRANTY, AND ANY CLAIMS FOR INCIDENTAL OR CONSEQUENTIAL DAMAGES ARE EXCLUDED.

No person is authorized to bind AgLand to any other warranty whatsoever.

AgLand reserves the right at any time to make changes or improvements to the design, materials, or specifications of the Macerator or parts without thereby becoming liable to make similar changes to the Macerator or any of its parts previously manufactured.

Manufactured by:
AgLand Industries Inc.

