

windrower | moldboard merger | swath spreader | tedder

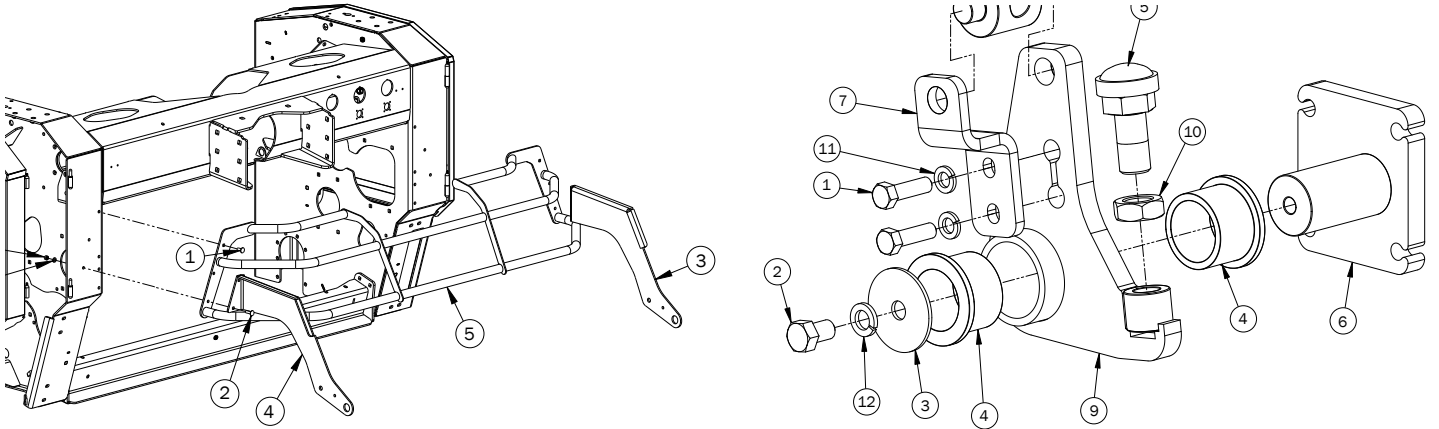

Macerator 6610



Parts Catalogue 2006

July 2006



Replacement Parts

To obtain prompt, efficient service, give the dealer the following information.

1. Correct stock number.
2. Model number of the machine.
3. Serial number of the machine.

The serial number is important in identifying your machine. It contains information for ordering replacement parts and options which may vary depending on the serial number identification.

Measurements are given in U.S. units followed by the equivalent in metric units. Hardware sizes are given in inches for the U.S. hardware and millimeters for the metric hardware.

All nuts and bolts are specified in Grade 5 unless otherwise specified.

AgLand	
Box 479 Arborg MB, R0C 0A0	
Model #:	Macerator 6610
Serial #:	
Made in Canada	

Serial # on plate inside right side cover.



AgLand Industries Inc.
Box 479 Arborg MB Canada R0C 0A0
☎ 1.888.933.4440
☎ 204.364.2211
☎ 204.364.2472
🌐 www.aglandindustries.com

AgLand Macerator 6610 Parts Order Form

Dealer Name: _____

Phone: _____ Fax: _____

Purchase Order: _____

Order Date: _____

Contact: _____

Date Required: _____

Qty	Part #	Description	Price

Order Name

Signature

Date

Note: Photocopy original and keep for future use.

Table of Contents

Macerator Parts Order Form	Front of Catalogue
Pickup, Guards & Shields Assembly	
View A.....	2-3
View B.....	4-5
Side Covers	6-7
Top Cover - Hingeable	8-9
Pickup	
Right Side.....	10-11
Left Side.....	12-13
Left Side Drive.....	14-15
Pickup Wrappers, Short	16-17
Main Frame & Hitch Assembly	18-19
Drive Line Assembly	20-21
Steel Roll Assembly	22-23
540 RPM Gearbox - MC611A	24-25
1000 RPM Gearbox - MC611	26-27
540 RPM Drive Shaft - MC612B	28-29
1000 RPM Drive Shaft - MC612C	30-31
Over-Running Clutch - MC617A	32-33
Gearbox U-Joints - MC616A	34-35
Right Side	
View A.....	36-37
View B.....	38-39
Drives.....	40-41
Left Side	
View A.....	42-43
View B.....	44-45
Drives.....	46-47
Lift Bracket Assembly - Right & Left Sides	48-49
Height Adjuster	50-51
Gap Adjusters	52-53
Axle Assembly	54-55
Wheel Hub Assembly	56-57
Hydraulics	58-59
Cylinder Assembly	60-61
Air System	62-63
Lights & Emblem Assembly	64-65
Attachments	
Attachment Brackets.....	66-67
Windrower Attachment Kit K101.....	68-69
Spreader, Adjustable Attachment Kit K102.....	70-71
Moldboard Attachment Kit K105.....	72-73
Tedder Attachment Kit K104.....	74-75
Tedder Attachment Kit K104 Hydraulics.....	76-77
Tedder Attachment Kit K104 Turnbuckle Assembly.....	78-79
Decals	80-81
Index	82-89
Warranty	Back Cover

Pickup, Guards & Shields Assembly - View A

Item No.	Stock No.	Description	Qty.
1	800159	Rivet, Steel, Blind, 0.187"	4
2	800396	Steel Latch	2

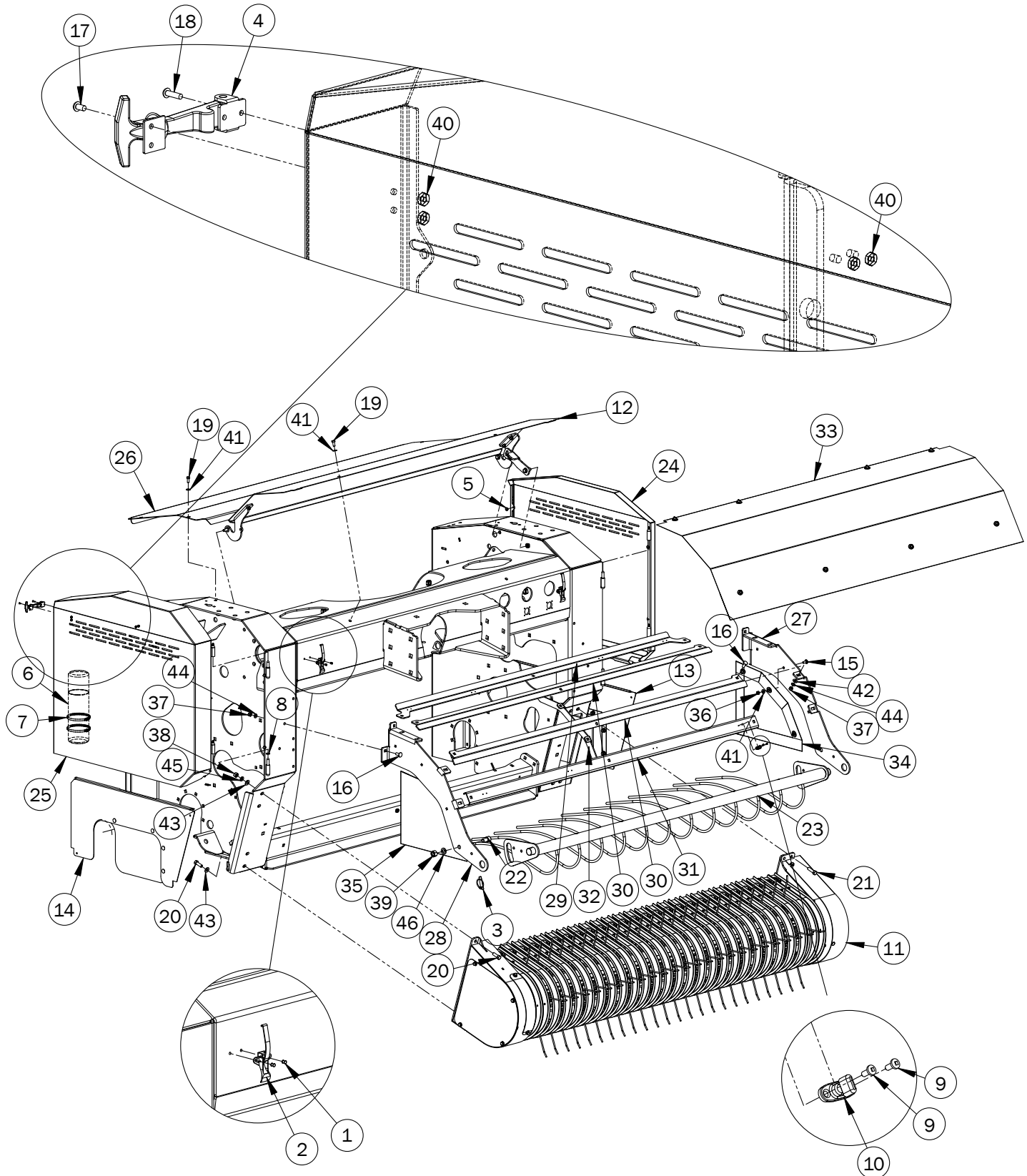

Pickup, Guards & Shields Assembly - View A

Item No.	Stock No.	Description	Qty.
3	801818	Pin, Lynch, 7/16"	2
4	804137	Draw Latch	4
5	807546	Silencer, Steel Door	8
6	807559	Container - Manual	1
7	807581	Clamp, Hose, #72	2
8	808476	Hinge Washer	4
9	808716	R1 No. 6 x 3/8" Screw, Sheetmetal, Round Head	16
10	808816	Stud, Twist Lock, Turn Fastener	8
11	804157r01	Pickup, Macerator (See pages 10-17)	1
12	-	Top Cover, Hingeable (See pages 8-9)	1
13	-	Cover, Side, L/H (See pages 6-7)	1
14	-	Cover, Side, R/H (See pages 6-7)	1
15	800062	5/16" x 3/4" Bolt, Carr.	6
16	800057	3/8" x 1" Bolt, Carr.	16
17	803611	6-32 x 1/4" Screw	8
18	803612	6-32 x 1/2" Screw	8
19	800209	5/16" x 3/4" Bolt, Standard	6
20	803625	7/16" x 1-1/4" Bolt, Standard	6
21	800219	7/16" x 1-1/2" Bolt, Standard	2
22	800231	5/8" x 1" Cap Screw, Socket Head	2
23	803780r02	Comb	1
24	803861r01	Door, L/H	1
25	803863r01	Door, R/H	1
26	803970r02	Top Cover, Rear	1
27	808682	Comb Arm, L/H	1
28	808678	Comb Arm, R/H	1
29	808685	Bar, Guard Front	1
30	808688	Bar, Guard Front	2
31	808694	Bar, Guard Front	1
32	808691	Support, Guard Front	1
33	808718	Screen, Main, Macerator	1
34	808720	Screen, Side, L/H, Macerator	1
35	808719	Screen, Side, R/H, Macerator	1
36	804194	5/16" Nut, Standard	6
37	800236	3/8" Nut, Standard	16
38	800240	7/16" Nut, Standard	3
39	804198	5/8" Nut, Standard	2
40	804191	6-32 Nut, Machine	16
41	807522	5/16" SAE Washer, Flat	12
42	807523	3/8" SAE Washer, Flat	12
43	807799	7/16" SAE Washer, Flat	8
44	804366	3/8" Washer, Lock	16
45	806556	7/16" Washer, Lock	8
46	804368	5/8" Washer, Lock	2

Pickup, Guards & Shields Assembly - View B

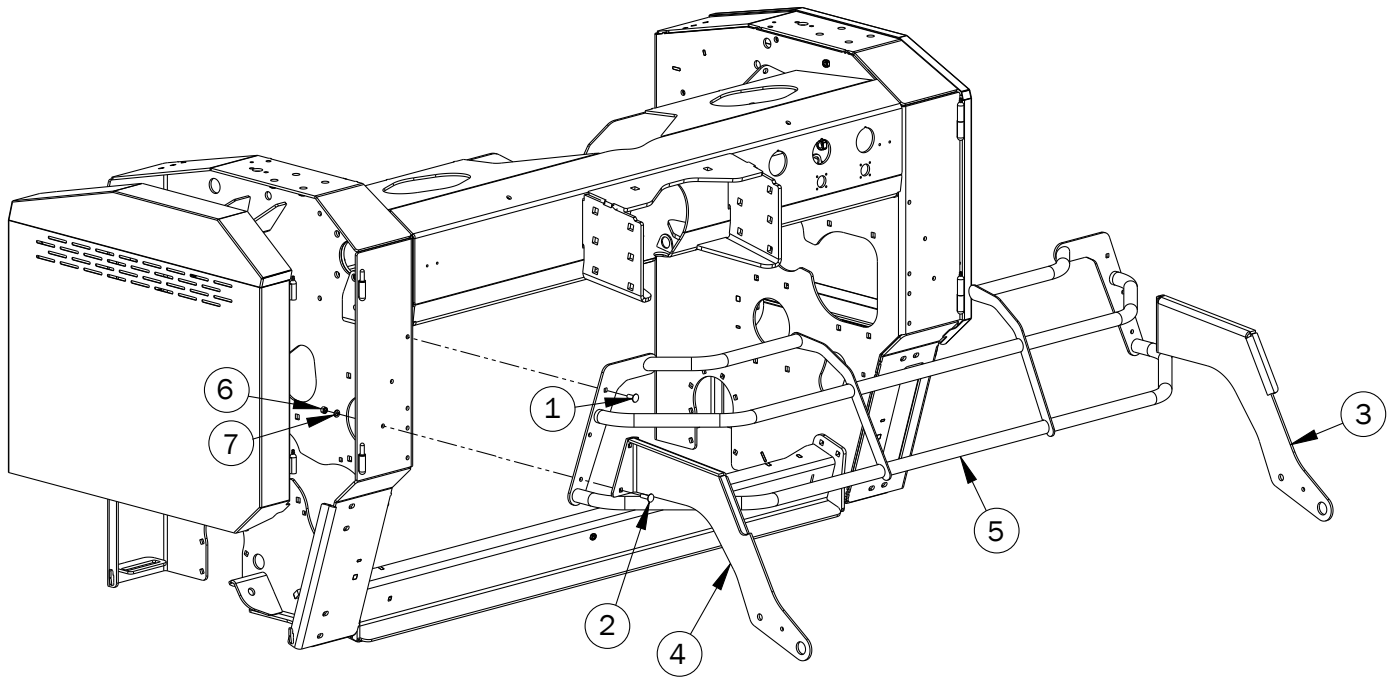

Pickup, Guards & Shields Assembly - View B

Item No.	Stock No.	Description	Qty.
1	800057	3/8" x 1" Bolt, Carr.	2
2	800059	3/8" x 1-1/4" Bolt, Carr.	4
3	807045	Comb Arm, L/H	1
4	807047	Comb Arm, R/H	1
5	804057r01	Guard	1
6	800236	3/8" Nut, Standard	6
7	804366	3/8" Washer, Lock	6

Side Covers

Side Cover - Right Side

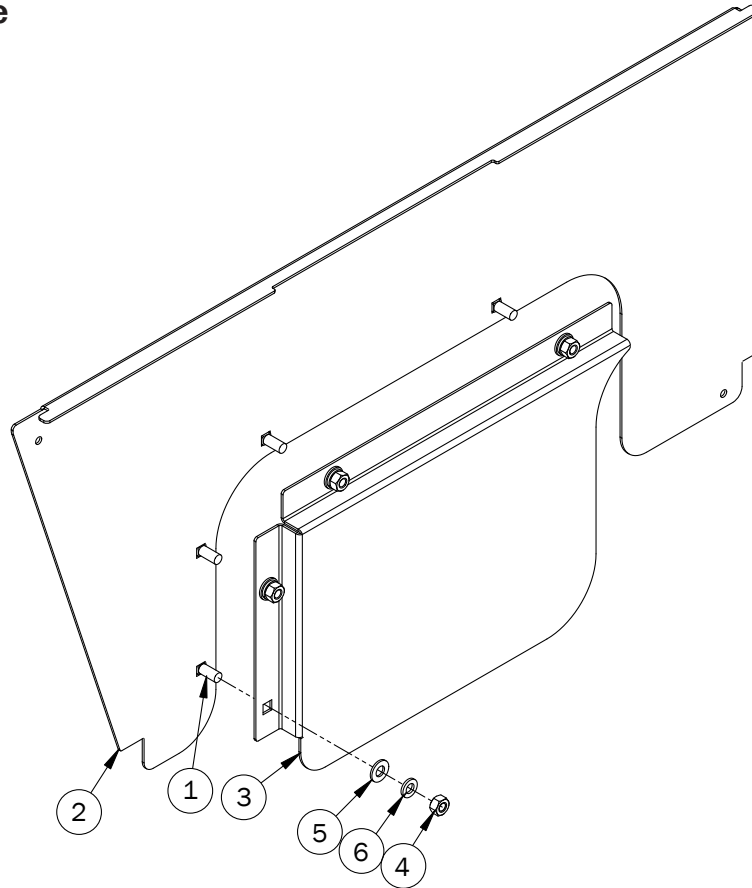

Side Cover - Left Side

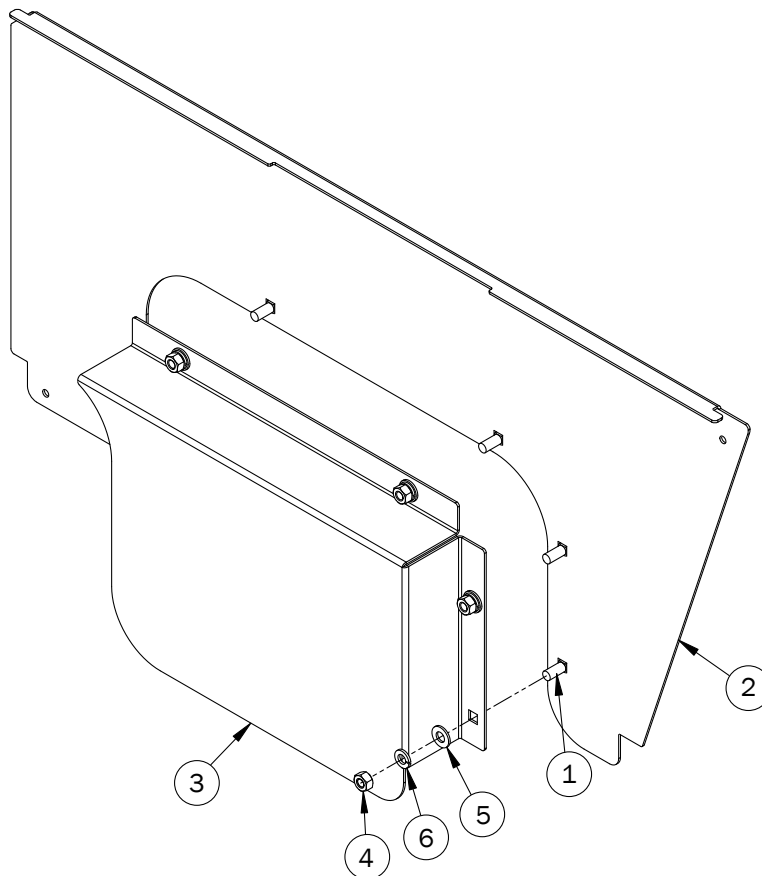

Side Covers**Side Cover - Right Side**

Item No.	Stock No.	Drawing No.	Description	Qty.
1	800062	5/16" x 3/4" Bolt, Carr.		4
2	810504	Cover, Side, R/H		1
3	810512	Plate, Cover, R/H		1
4	804194	5/16" Nut, Standard		4
5	807522	5/16" SAE Washer, Flat		4
6	807528	5/16" Washer, Lock		4

Side Cover - Left Side

Item No.	Stock No.	Description	Qty.
1	800062	5/16" x 3/4" Bolt, Carr.	4
2	810501	Cover, Side, L/H	1
3	810509	Plate, Cover, L/H	1
4	804194	5/16" Nut, Standard	4
5	807522	5/16" SAE Washer, Flat	4
6	807528	5/16" Washer, Lock	4

Top Cover - Hingeable

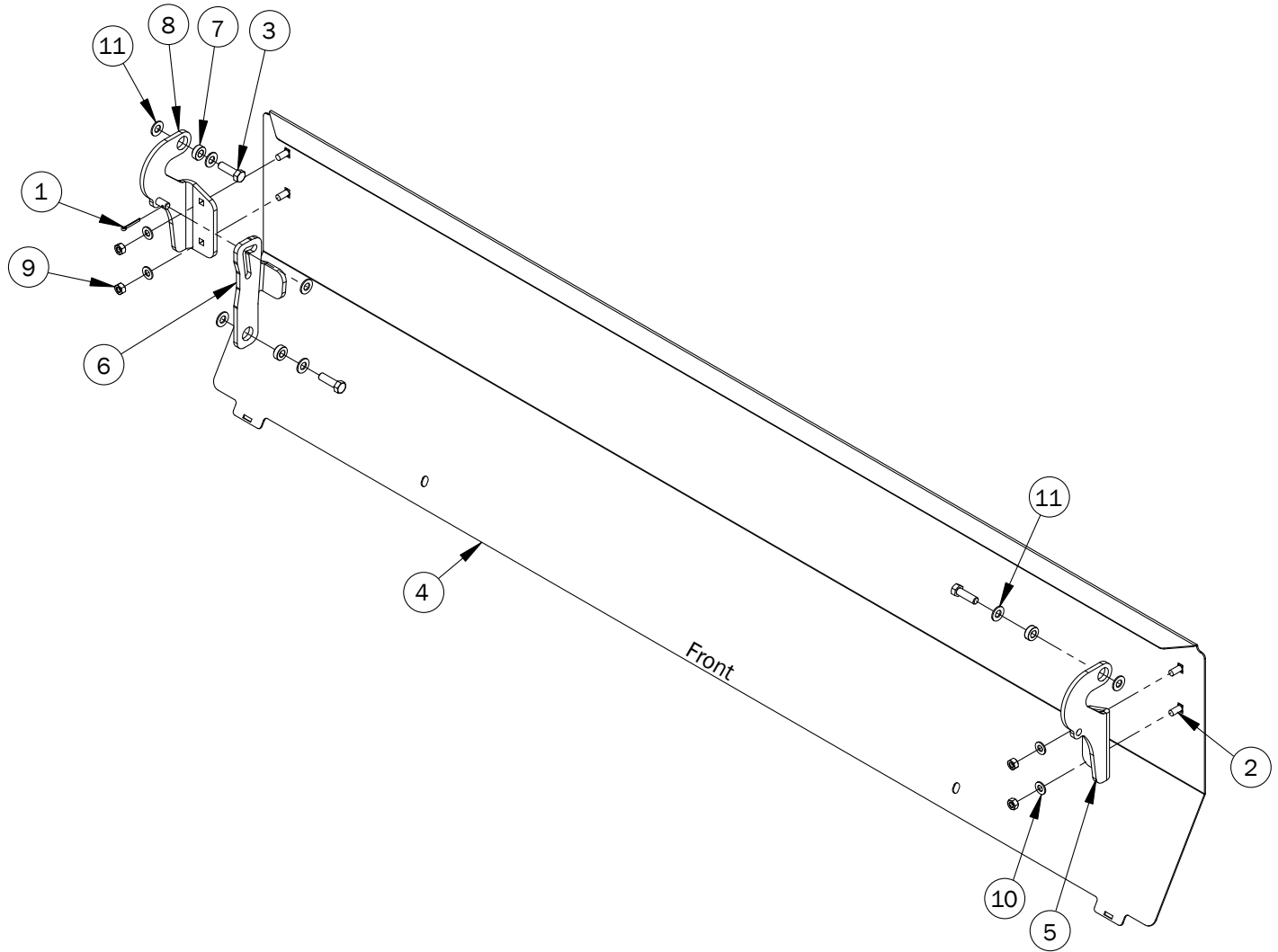

Top Cover - Hingeable

Item No.	Stock No.	Description	Qty.
1	807685	Pin, Cotter, 0.125" x 1"	1
2	800062	5/16" x 3/4" Bolt, Carr.	4
3	800197	3/8" x 1-1/4" Bolt, Standard	3
4	807043	Top Hingeable Cover	1
5	807034	Top Cover Hinge Brk, R/H	1
6	807035	Top Cover Hinge Brace	1
7	803994	7mm Bushing 3/8" ID	3
8	807033	Hinge - Top Cover	1
9	804194	5/16" Nut, Standard	4
10	807522	5/16" SAE Washer, Flat	4
11	807523	3/8" SAE Washer, Flat	7

Pickup - Right Side

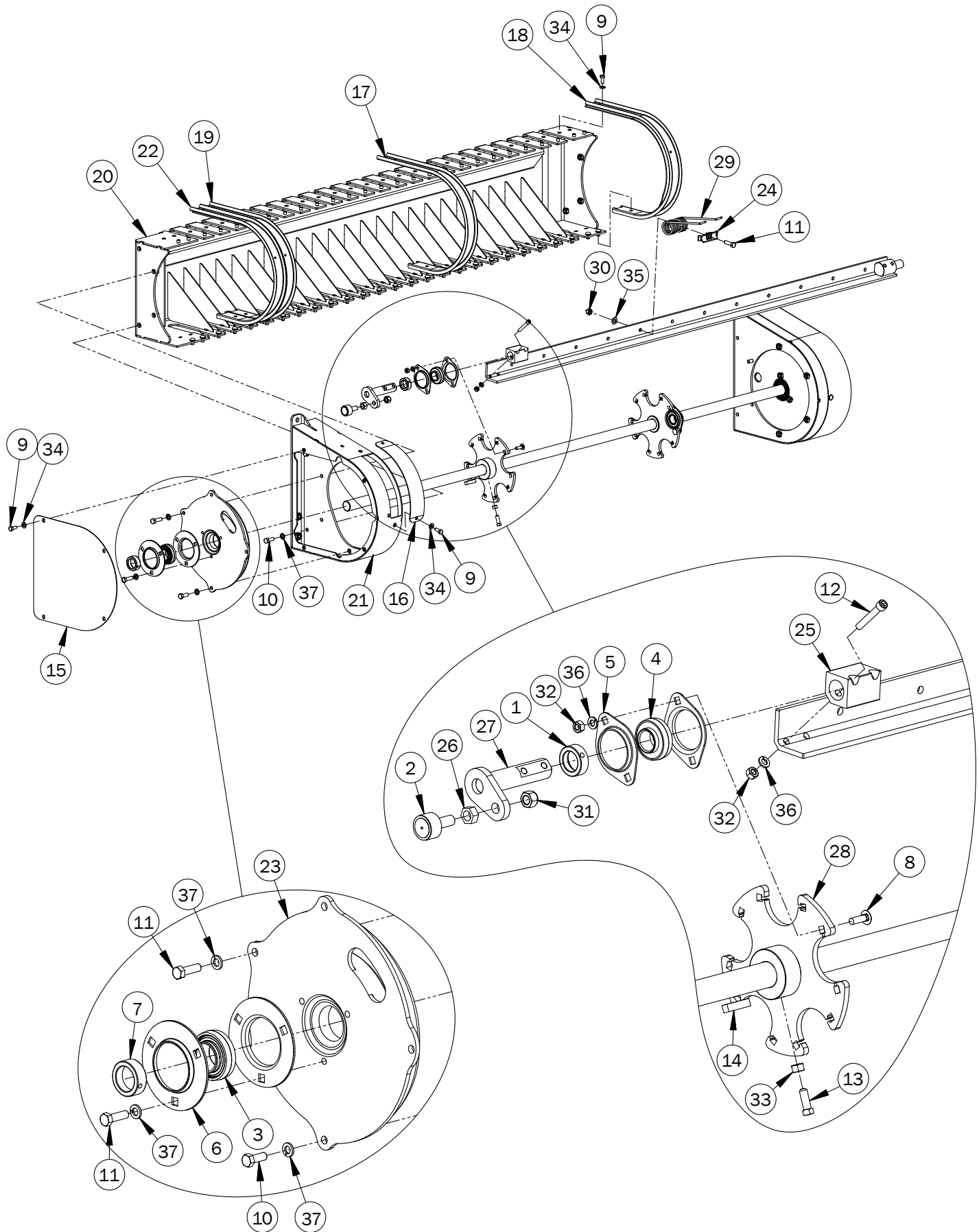

Pickup - Right Side

Item No.	Stock No.	Description	Qty.
1	800045	Collar, Locking	5
2	804059	Stud Bearing	5
3	804061	Bearing/Locking Collar	1
4	804062	Bearing/Locking Collar	5
5	804064	Bearing Flange, 2 Bolt	10
6	804066	Bearing Flange, 3 Bolt	2
7	808355	Collar, Locking	1
8	807516	5/16" x 1" Bolt, Carr.	10
9	800209	5/16" x 3/4" Bolt, Standard	33
10	800195	3/8" x 1" Bolt, Standard	5
11	800197	3/8" x 1-1/4" Bolt, Standard	65
12	800228	5/16" x 2" Cap Screw, Socket Head, Gr. 8	10
13	800259	3/8" x 1" Setscrew, Sq Hd	2
14	807869	3/8" x 1-1/2" Key	1
15	803716r02	Cover, Pickup	1
16	803722	Access Cover	1
17	803730r01	Wrapper, Pickup	23
18	803732r01	Pickup Wrapper, Short, L/H (See pages 16-17)	1
19	803734r01	Pickup Wrapper, Short, R/H (See pages 16-17)	1
20	803742r02	Pickup Cross Frame	1
21	803746r03	Pickup Frame, R/H	1
22	803748r01	Wrapper, Pickup End, Short	2
23	807406	Cam Track	1
23	810787	Cam Track - Heavy Duty	1
24	808596	Clamp, Pickup Tooth	60
25	803765	Tooth Bar, Block	5
26	803767	Cam Bearing Spacer	5
27	803773	Cam Arm	5
28	810383	Bearing Bracket Star Wheel	1
29	804113	Tooth, Pickup	60
30	806636	3/8" Nut, Pinch Lock	60
31	804190	1/2" Nut, Pinch Lock, Fine Thread	5
32	804194	5/16" Nut, Standard	20
33	800236	3/8" Nut, Standard	2
34	807522	5/16" SAE Washer, Flat	33
35	807523	3/8" SAE Washer, Flat	60
36	807528	5/16" Washer, Lock	20
37	804366	3/8" Washer, Lock	10
38	809470	Tooth Clamp Kit (Including items 11, 24, 29, 30 and 35.)	1

Pickup - Left Side

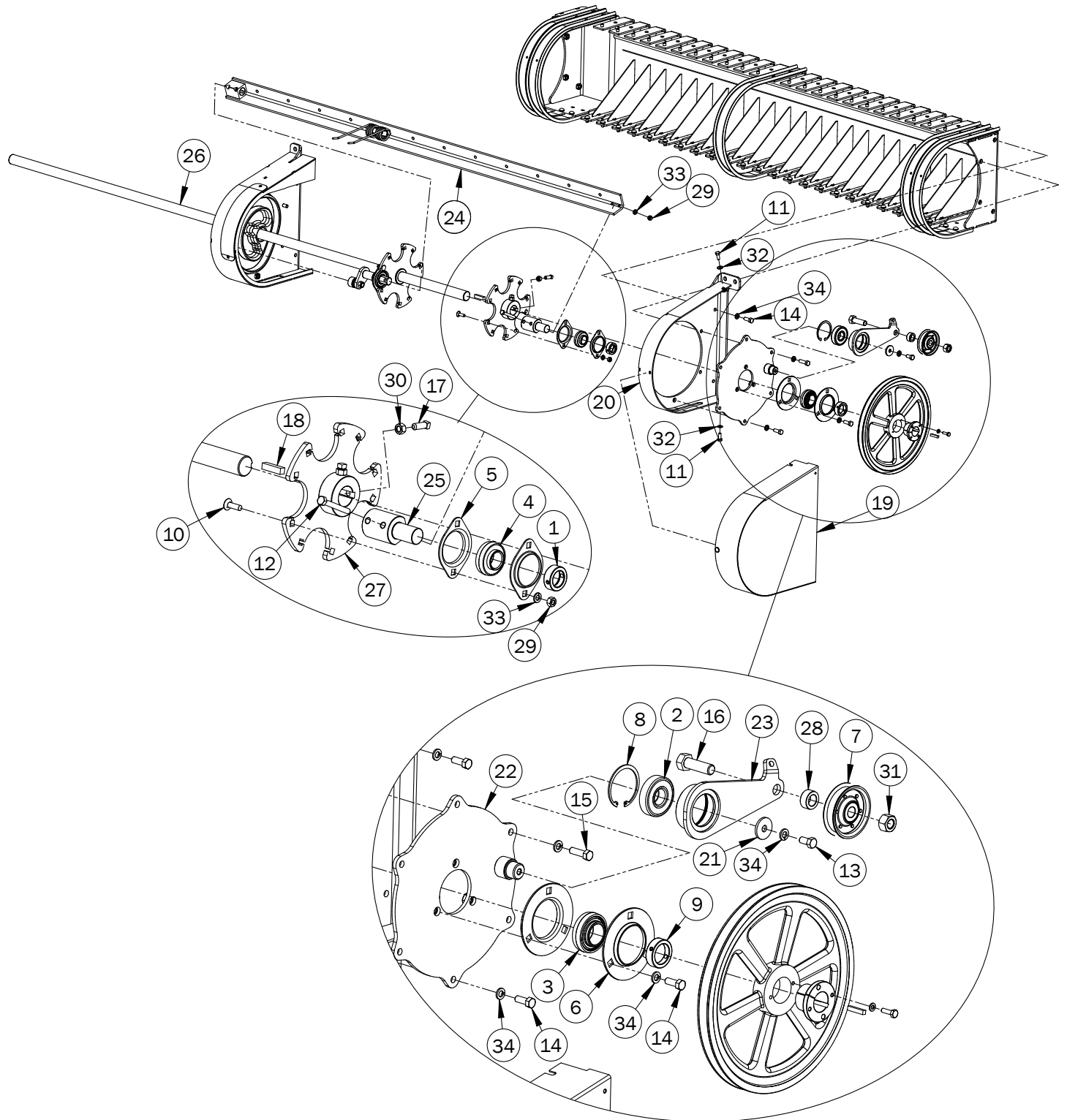

Pickup - Left Side

Item No.	Stock No.	Description	Qty.
1	800045	Collar, Locking	5
2	803586	Bearing	1
3	804061	Bearing	1
4	804062	Bearing	5
5	804064	Bearing Flange, 2 Bolt	10
6	804066	Bearing Flange, 3 Bolt	2
7	804237	3" Flat Idler	1
8	807402	Internal Retaining Ring	1
9	808355	Collar, Locking	1
10	807516	5/16" x 1" Bolt, Carr.	10
11	800209	5/16" x 3/4" Bolt, Standard	2
12	800207	5/16" x 2-1/2" Bolt, Standard, Gr. 8	10
13	803623	3/8" x 3/4" Bolt, Standard	1
14	800195	3/8" x 1" Bolt, Standard	9
15	800197	3/8" x 1-1/4" Bolt, Standard	2
16	800212	5/8" x 2" Bolt, Standard	1
17	800259	3/8" x 1" Setscrew, Sq Hd	2
18	807869	3/8" x 1-1/2" Key	1
19	807101	Pickup Side Cover	1
20	803744r03	Pickup Frame, L/H	1
21	807472	Washer	1
22	803755r02	Plate, Holder, Bearing	1
23	803760r01	Tightener Arm, Pickup Belt	1
24	803764	Tooth Bar	5
25	803766	Tooth Bar Shaft	5
26	810386	Main Shaft, Pickup	1
27	810383	Bearing Bracket Star Wheel	1
28	804042r02	Spacer - Belt Tightener	1
29	804194	5/16" Nut, Standard	20
30	800236	3/8" Nut, Standard	2
31	804198	5/8" Nut, Standard	1
32	807522	5/16" SAE Washer, Flat	2
33	807528	5/16" Washer, Lock	20
34	804366	3/8" Washer, Lock	12

Pickup - Left Side Drive

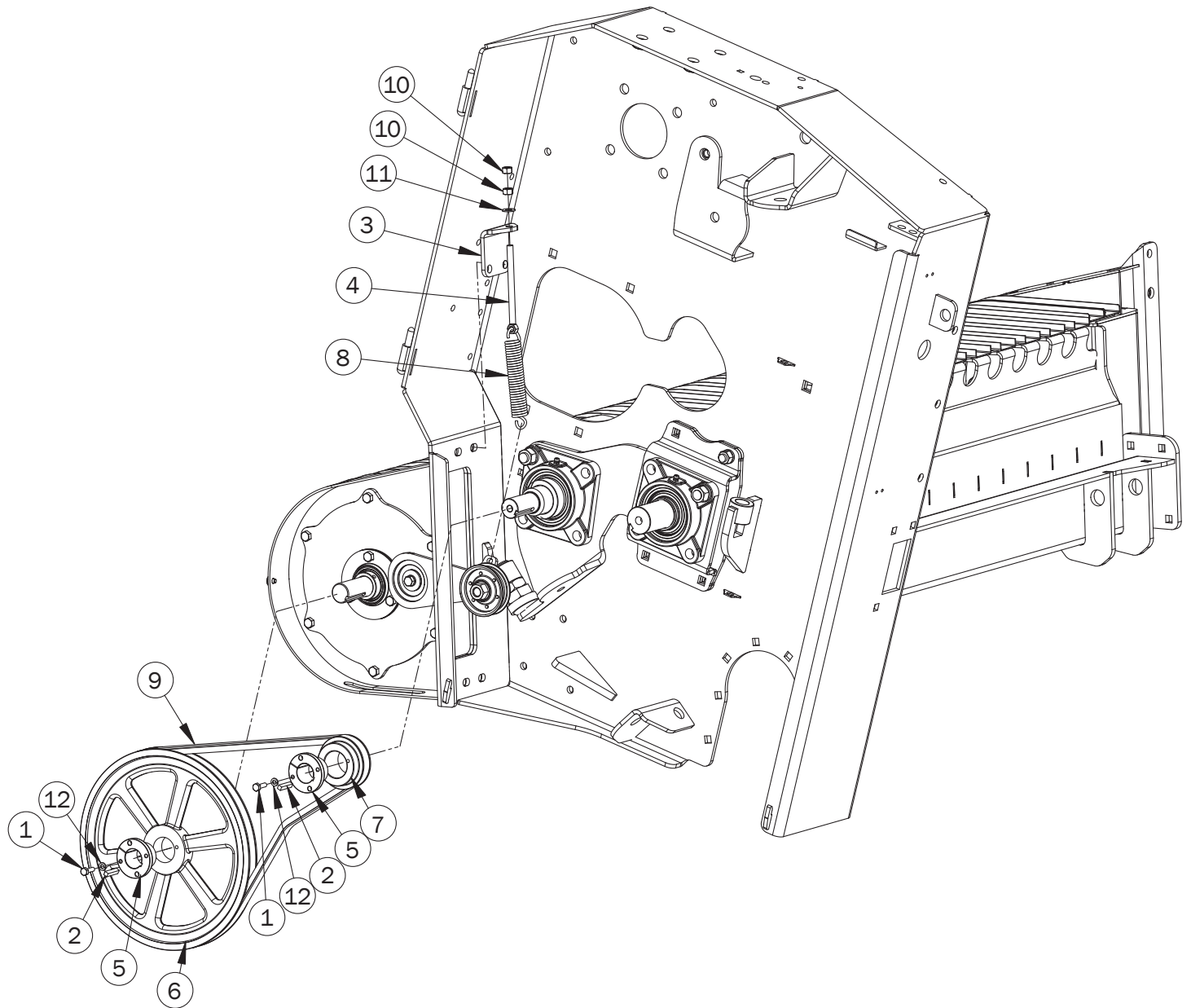

Pickup - Left Side Drive

Item No.	Stock No.	Description	Qty.
1	808111	1/4" x 7/8" Bolt, Standard	4
2	803660	1/4" x 1-1/4" Key	2
3	807037	Tightener Pull Bracket - Pickup	1
4	803761	Tightening Rod	1
5	801171	L 1-1/4" Hub	2
6	804238	MBL127 Pulley	1
7	804239	MBL33 Pulley	1
8	804134	Spring Extension Pickup Idler	1
9	802922	V-Belt, BX54	1
10	800236	3/8" Nut, Standard	2
11	807523	3/8" SAE Washer, Flat	1
12	808353	1/4" Washer, Lock	4

Pickup Wrappers, Short

Pickup Wrapper, Short - Right Side MC118R

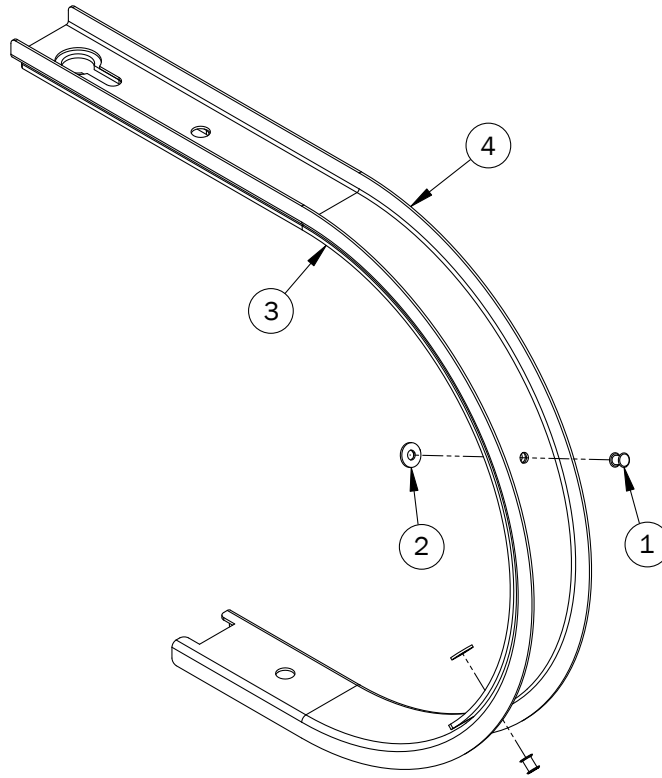

Pickup Wrapper, Short - Left Side MC118L

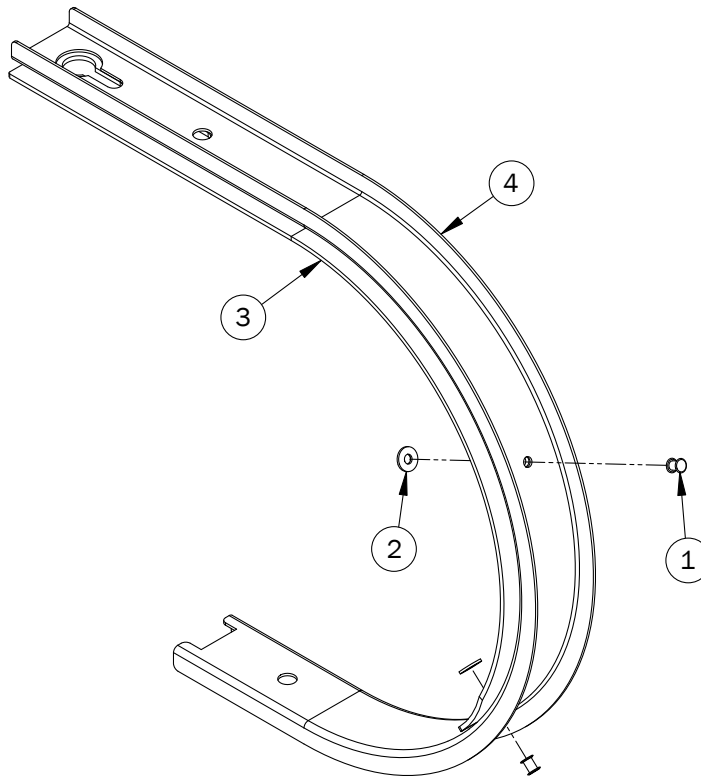

Pickup Wrappers, Short

Pickup Wrapper, Short - Right Side MC118R

Item No.	Stock No.	Drawing No.	Description	Qty.
1	800159	800159	Rivet, Steel, Blind, 0.187"	2
2	800276	800276	No. 10 Washer, Flat	2
3	803729	MC114B	Spacer, Pickup Wrapper	1
4	803733r01	MC114S	Wrapper, Pickup	1

Pickup Wrapper, Short - Left Side MC118L

Item No.	Stock No.	Description	Qty.
1	800159	Rivet, Steel, Blind, 0.187"	2
2	800276	No. 10 Washer, Flat	2
3	803729	Spacer, Pickup Wrapper	1
4	803733r01	Wrapper, Pickup	1

Main Frame & Hitch Assembly

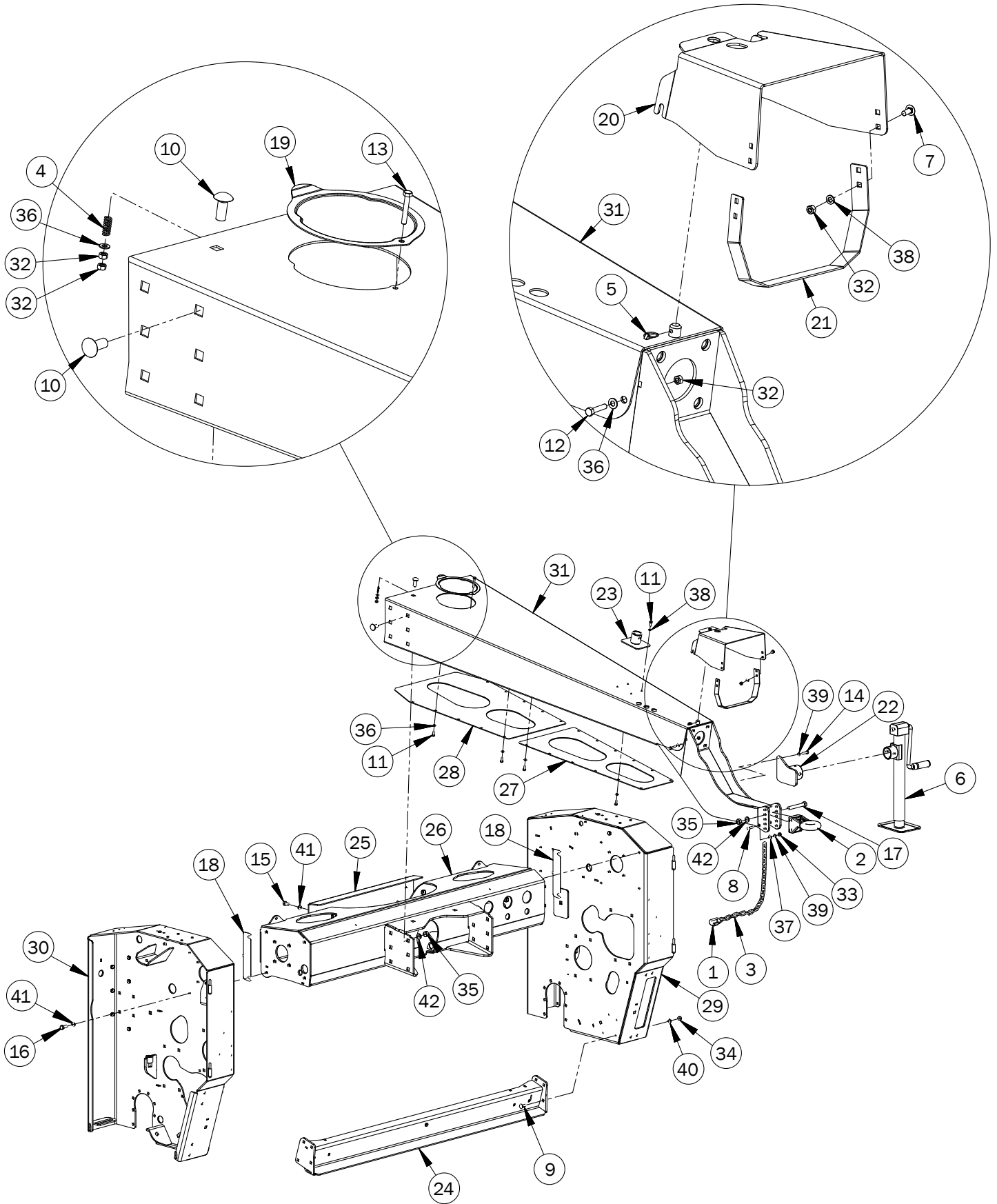

Main Frame & Hitch Assembly

Item No.	Stock No.	Description	Qty.
1	803622	Quick Link, Chain, 5/16"	2
2	804090	Cast Hitch	1
3	804110	Chain, Travel Safety	2
4	804301	Spring, Compression	1
5	807403	3/16" Lynch Pin	1
6	807550	Side Wind Jack	1
7	800062	5/16" x 3/4" Bolt, Carr.	4
8	800059	3/8" x 1-1/4" Bolt, Carr.	2
9	800073	7/16" x 1-1/4" Bolt, Carr.	8
10	800064	5/8" x 1-1/2" Bolt, Carr.	14
11	800209	5/16" x 3/4" Bolt, Standard	26
12	800205	5/16" x 1-1/2" Bolt, Standard	2
13	800206	5/16" x 2" Bolt, Standard	1
14	800197	3/8" x 1-1/4" Bolt, Standard	4
15	800164	1/2" x 1" Bolt, Standard	4
16	800166	1/2" x 1-1/4" Bolt, Standard	8
17	800216	5/8" x 4-1/2" Bolt, Standard	2
18	808714	Shim, Main Crossbeam (Optional)	-
19	803824	Drive Line Service Cover	1
20	803827	Cover, Safety, PTO	1
21	807578	Strap - Safety, PTO	1
22	803855	Jack Mount Bracket	1
23	803857	Jack Storage Bracket	1
24	803869	Crossbeam, Cylinder	1
25	810473	Plate, Reinforcement, Crossbeam	1
26	810437	Crossbeam, Main	1
27	810427	Cover, Front, A-Frame	1
28	810429	Cover, Back, A-Frame	1
29	810392	Main Frame, L/H	1
30	810388	Main Frame, R/H	1
31	810446	A-Frame	1
32	804194	5/16" Nut, Standard	8
33	800236	3/8" Nut, Standard	2
34	800240	7/16" Nut, Standard	8
35	804198	5/8" Nut, Standard	16
36	807522	5/16" SAE Washer, Flat	25
37	807523	3/8" SAE Washer, Flat	2
38	807528	5/16" Washer, Lock	8
39	804366	3/8" Washer, Lock	6
40	806556	7/16" Washer, Lock	8
41	804367	1/2" Washer, Lock	12
42	804368	5/8" Washer, Lock	16

Drive Line Assembly

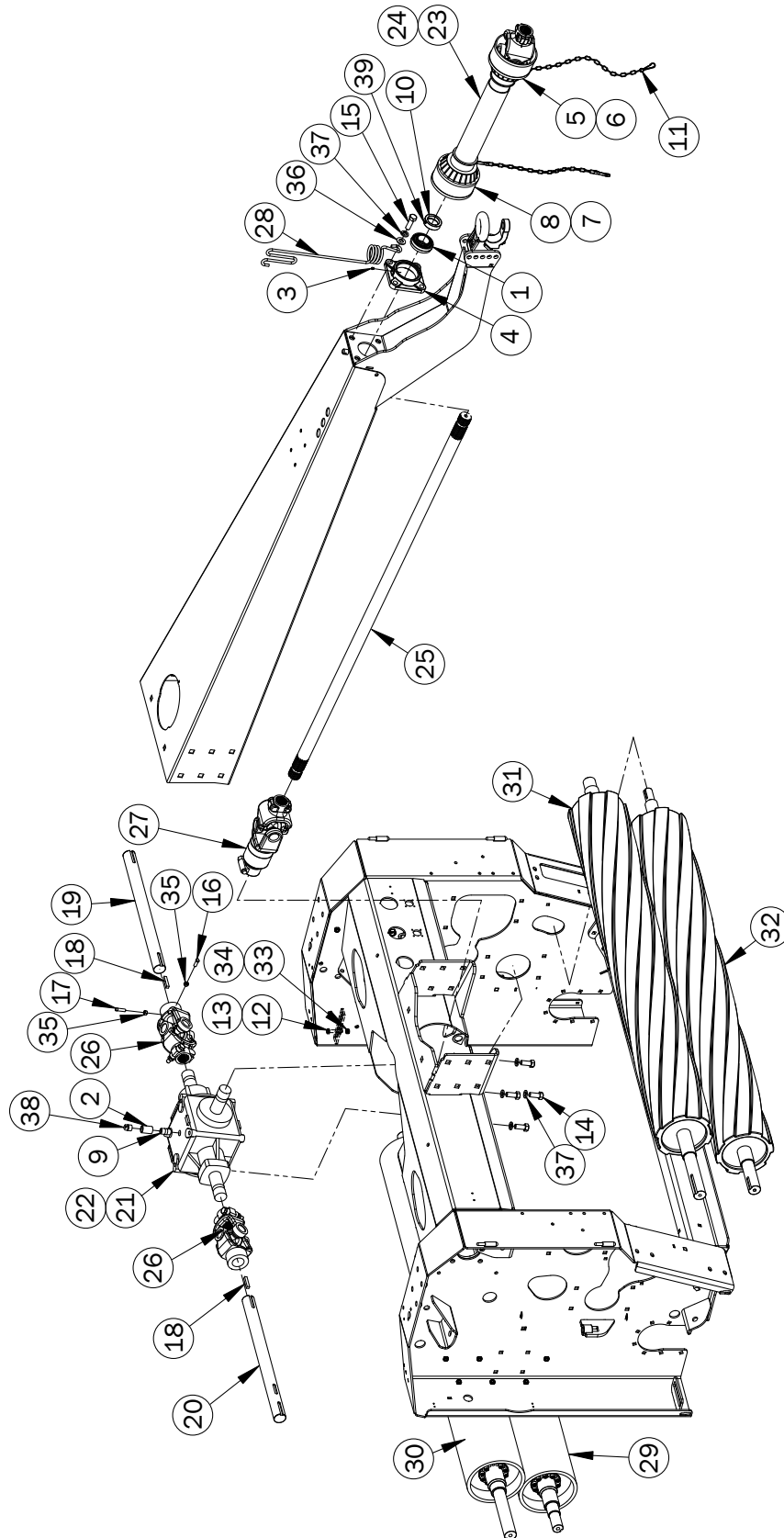

Drive Line Assembly

Item No.	Stock No.	Description	Qty.
1	800048	Bearing	1
2	800876	Coupling, Black 1/2"	1
3	807558	Nipple, Grease 1/4" NF	1
4	807890	Housing, 4 Bolt	1
5	808044	Shaft, Outer Half, 1000 RPM	1
6	808045	Shaft, Outer Half, 540 RPM	1
7	808046	Shaft, Inner Half, 540 RPM	1
8	808047	Shaft, Inner Half, 1000 RPM	1
9	808107	Nipple, Black 1/2" x 1-1/2"	1
10	808109	Collar, Locking	1
11	808776	Chain, Safety Tube, PTO	2
12	807784	10mm x 50mm Bolt, Metric (Shear Bolt 1000 RPM)	5
13	807791	12mm x 50mm Bolt, Metric (Shear Bolt 540 RPM)	5
14	800211	5/8" x 1-1/2" Bolt, Standard	4
15	800212	5/8" x 2" Bolt, Standard	4
16	800259	3/8" x 1" Setscrew, Sq Hd	2
17	807156	3/8" x 1-1/4" Setscrew, Sq Hd	2
18	803662	3/8" x 2" Key	2
19	803897	Stub, Drive Shaft	1
20	807041	Stub, Drive Shaft	1
21	804081	Gear Box, Black, 1000 RPM (See pages 26-27)	1
22	804082	Gear Box, Silver, 540 RPM (See pages 24-25)	1
23	807562	PTO Drive Shaft Assembly, 540 RPM	1
24	807563	PTO Drive Shaft Assembly, 1000 RPM	1
25	804087	Drive Shaft	1
26	807565	U Joint (See pages 34-35)	2
27	807564	Over-Running Clutch (See pages 32-33)	1
28	807513	Spring - Hose Holder	1
29	804114r02	Bottom Steel Roll (See pages 22-23)	1
30	804115r03	Top Steel Roll (See pages 22-23)	1
31	801609r02	Top Rubber Roll	1
32	801612r01	Bottom Rubber Roll	1
33	804189	10mm Nut, Nylon Lock (1000 RPM)	5
34	807792	12mm Nut, Nylon Lock (540 RPM)	5
35	800236	3/8" Nut, Standard	4
36	807525	5/8" SAE Washer, Flat	1
37	804368	5/8" Washer, Lock	8
38	807866	Vent: 1/2 NPT	1
39	808200	Screw, Set, 3/8" x 3/8"	1

Steel Roll Assembly

Top Steel Roll Assembly MC761

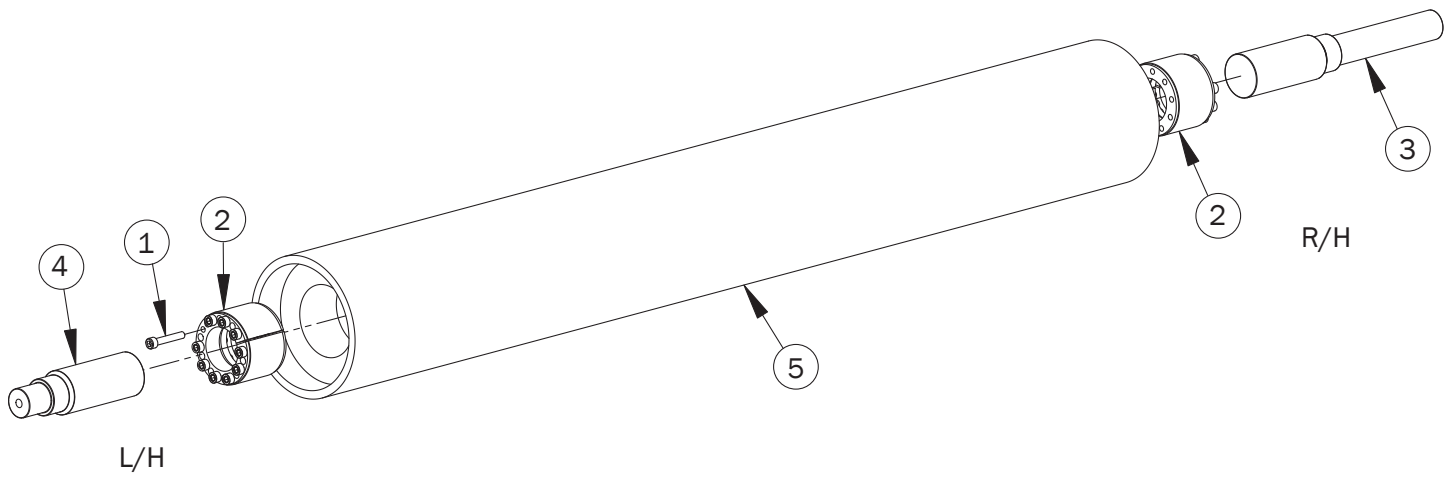

Bottom Steel Roll Assembly MC760

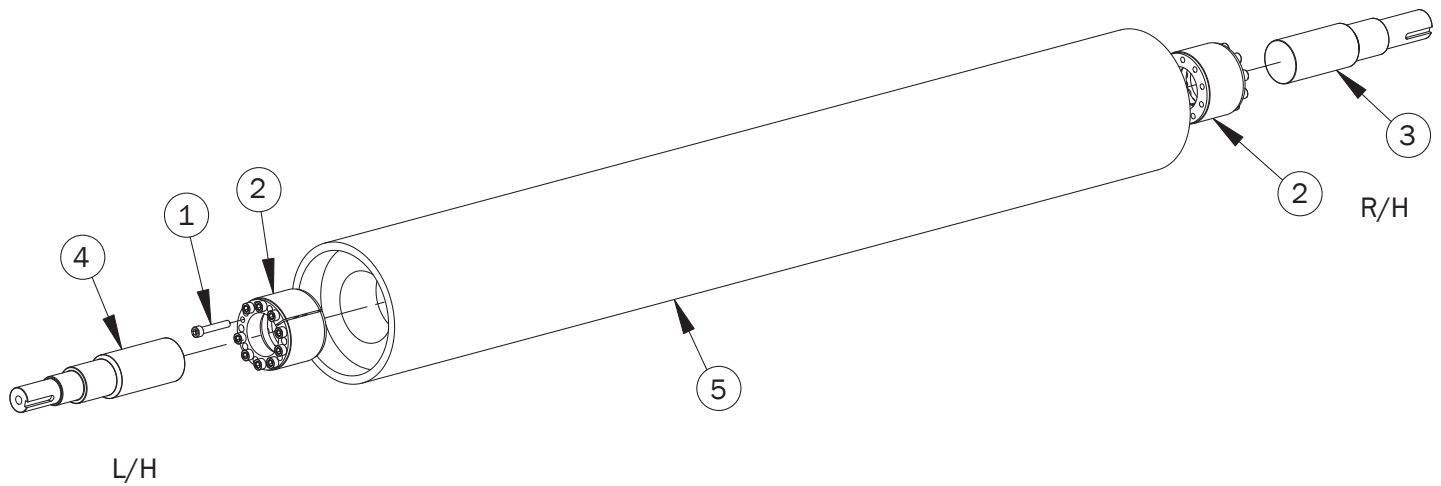

Steel Roll Assembly

Top Steel Roll Assembly MC761

Item No.	Stock No.	Description	Qty.
1	808123	10mm x 60mm Capscrew, Socket Head, Gr. 8	20
2	808128	B-Lock Hub	2
3	808359	Stub Shaft, R/H	1
4	808360	Stub Shaft, L/H	1
5	808352	Steel Roll Tube	1

Bottom Steel Roll Assembly MC760

Item No.	Stock No.	Description	Qty.
1	808123	10mm x 60mm Capscrew, Socket Head, Gr. 8	20
2	808128	B-Lock Hub	2
3	808357	Stub Shaft, R/H	1
4	808358	Stub Shaft, L/H	1
5	808352	Steel Roll Tube	1

540 RPM Gearbox - MC611A

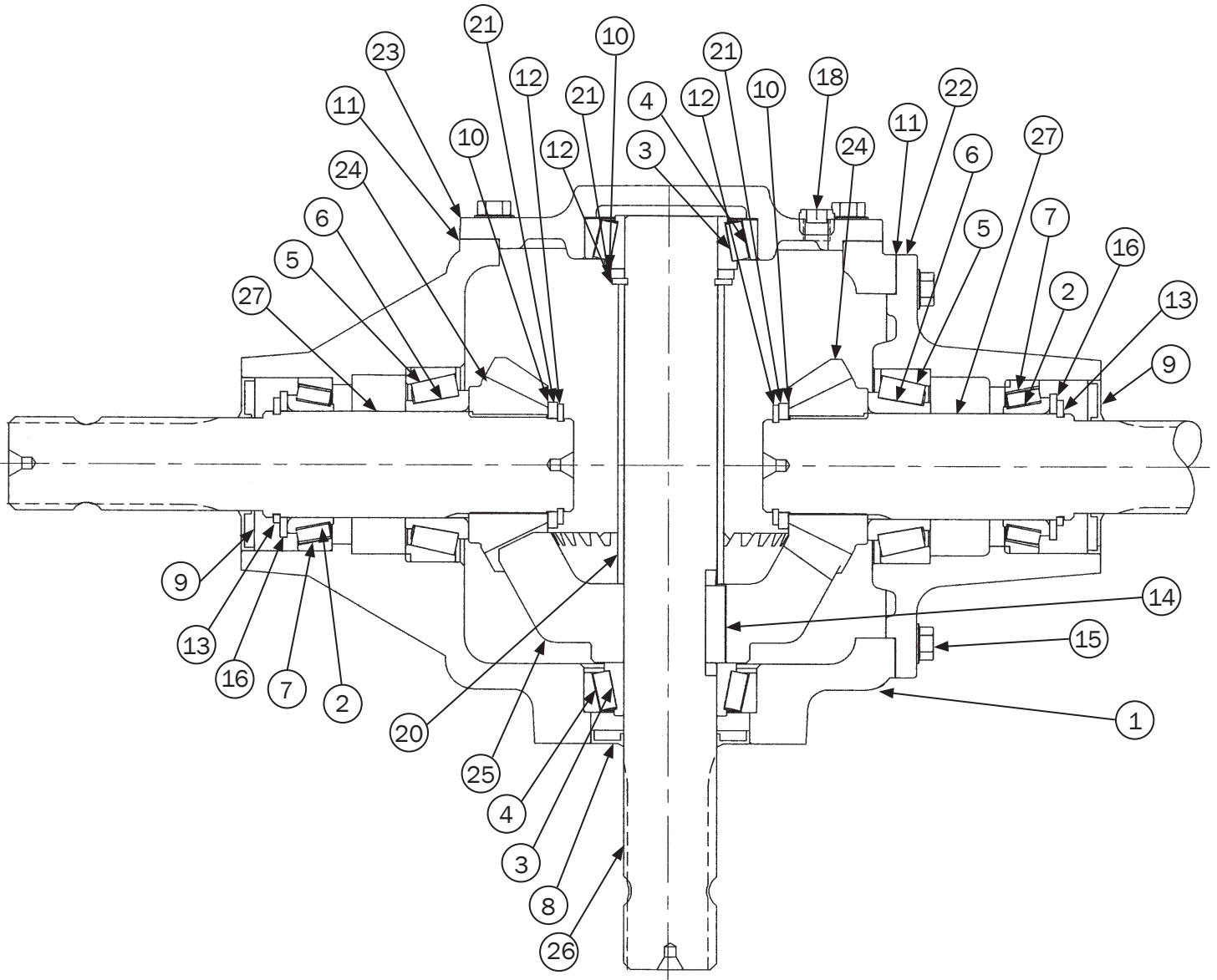

540 RPM Gearbox - MC611A

Item No.	Stock No.	Description	Qty.
1	807746	Case - 900	1
2	807824	Brg. Cone LM104949	2
3	807825	Brg. Cone 25581	2
4	807820	Brg. Cup 25520	2
5	807819	Brg. Cup 3730	2
6	807823	Brg. Cone 3780	2
7	807818	Brg. Cup LM104912	2
8	806268	Oil Seal - Viton	1
9	806269	Oil Seal - Viton Ø1.75 - 3.27	2
10	807847	Shim - Ø1.75 - .007	3
11	807747	Shim - Cover	2
12	807839	Snap Ring (5160 - 175)	3
13	807838	Snap Ring (5160 - 200)	2
14	803662	Key: 3/8 Sq.	1
15	800195	Bolt: 3/8 - 16UNC - 1.00	16
16	807835	Washer: Ø2.00 - .134	2
17	804142	Plug: 1/2 NPT	1
18	800972	Plug: 3/8 NPT	1
19	807866	Vent: 1/2 NPT	1
20	807853	Spacer Tube	1
21	807837	Washer: Ø1.75 - .179	3
22	807749	Quill Housing	1
23	807852	Cover - Closed 3/8 NPT	1
24	807750	Pinion - 16T	2
25	807841	Gear - 29T	1
26	807851	Shaft - Cross	1
27	807836	Shaft - Quill	2

1000 RPM Gearbox - MC611

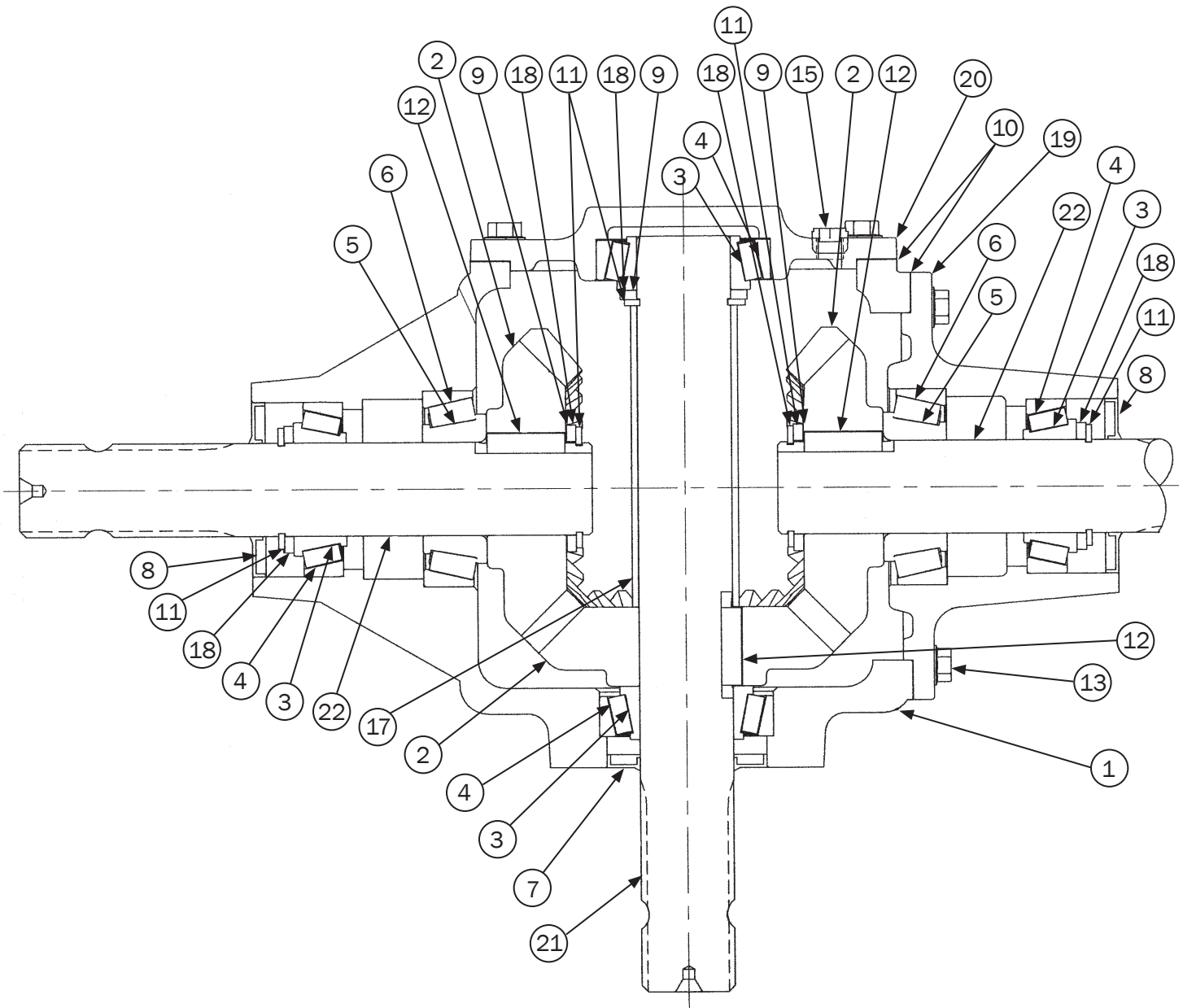

1000 RPM Gearbox - MC611

Item No.	Stock No.	Description	Qty.
1	807746	Case - 900	1
2	807843	Gear - 22T	3
3	807825	Brg. Cone 25581	4
4	807820	Brg. Cup 25520	4
5	807826	Brg. Cone 3782	2
6	807819	Brg. Cup 3730	2
7	806268	Oil Seal - Viton	1
8	806269	Oil Seal - Viton Ø1.75 - 3.27	2
9	807847	Shim - Ø1.75 - .007	3
10	807747	Shim - Cover	2
11	807839	Snap Ring (5160 - 175)	5
12	803662	Key: 3/8 Sq.	3
13	800195	Bolt: 3/8 - 16UNC - 1.00	16
14	804142	Plug: 1/2 NPT	1
15	800972	Plug: 3/8 NPT	1
16	807866	Vent: 1/2 NPT	1
17	807853	Spacer Tube	1
18	807837	Washer: Ø1.75 - .179	5
19	807749	Quill Housing	1
20	807852	Cover - Closed 3/8 NPT	1
21	807851	Shaft - Cross	1
22	806138	Shaft - Quill	2

540 RPM Drive Shaft - MC612B

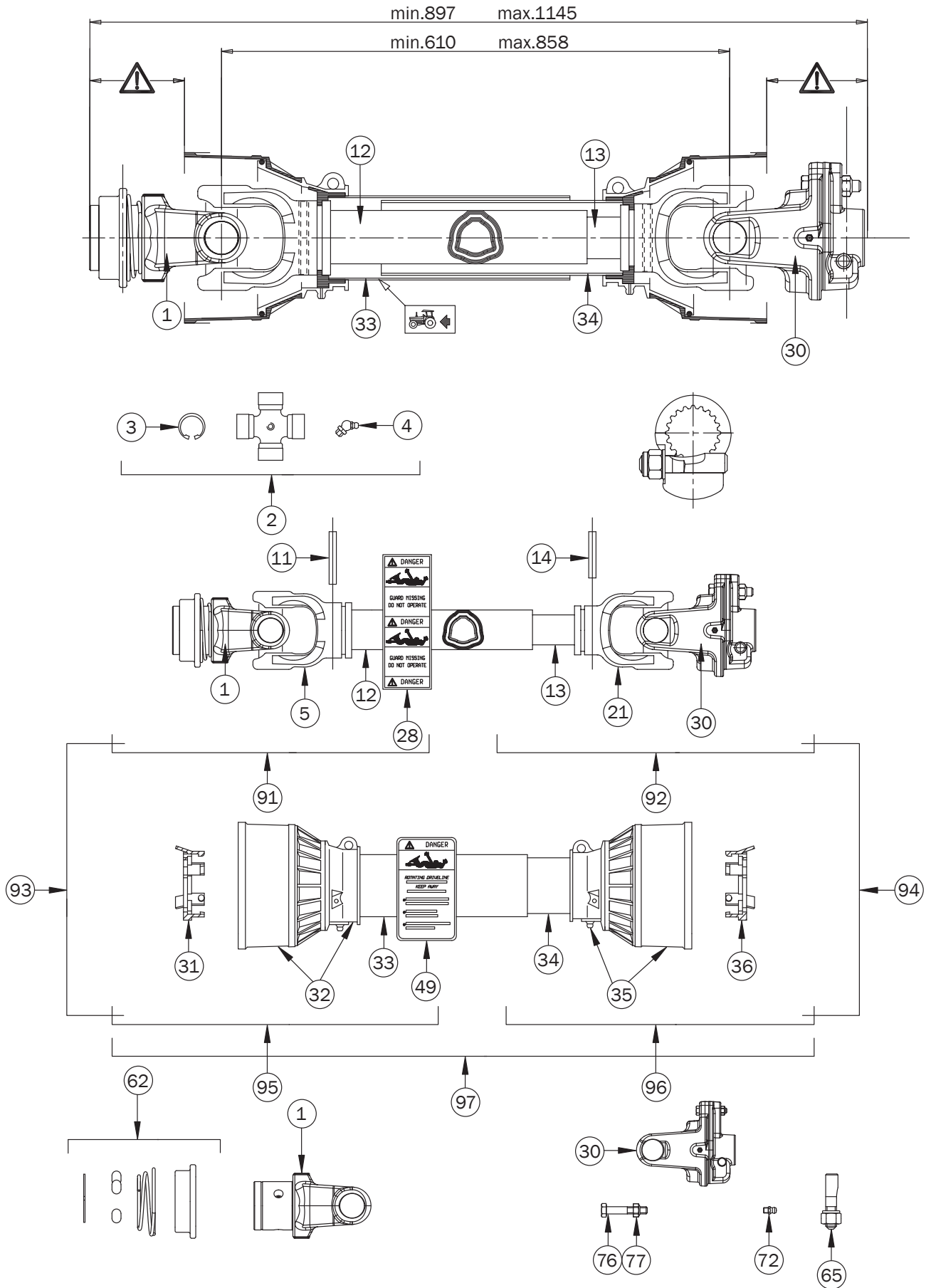

540 RPM Drive Shaft - MC612B

Item No.	Stock No.	Description	Qty.
1	807964	Yoke S9 1 3/8Z6 RT	1
2	807966	Cross Journal Assembly	2
3	807969	Circlip	8
4	807970	Grease Zerk	2
5	807972	Outer Tube Yoke	1
11	808016	Flexible Pin	1
12	808018	Cardan Tube, Outer	1
13	808019	Cardan Tube, Inner	1
14	808022	Flexible Pin	1
21	808024	Inner Yoke Tube	1
28	808025	Label	1
30	808028	LB Torque Limiter Yoke Assembly	1
31	808030	Shield Supporter 8-9-0	1
32	808033	O. Cone Sets F8-9	1
33	808040	Safety Tube	1
34	808039	Safety Tube	1
35	808034	I. Cone Sets F8-9	1
36	808032	Shield Support 8-9-0	1
49	808026	Label	1
62	808041	Ball Collar Kit	1
65	808043	Pin/Nut	1
72	808064	Grease Nipple	1
76	807791	Bolt, 12 x 50mm (PTO Shear Bolt, 540 RPM)	1
77	807792	12mm Nylon Locknut (540 RPM)	1
91	808045	Outer Half Shaft	1
92	808046	Inner Half Shaft	1
93	808049	Outer Half Shaft Assembly	1
94	808050	Inner Half Shaft Assembly	1
95	808053	Outer Half Shaft Shield	1
96	808054	Inner Half Shaft Shield	1
97	808057	Complete Shield	1

1000 RPM Drive Shaft - MC612C

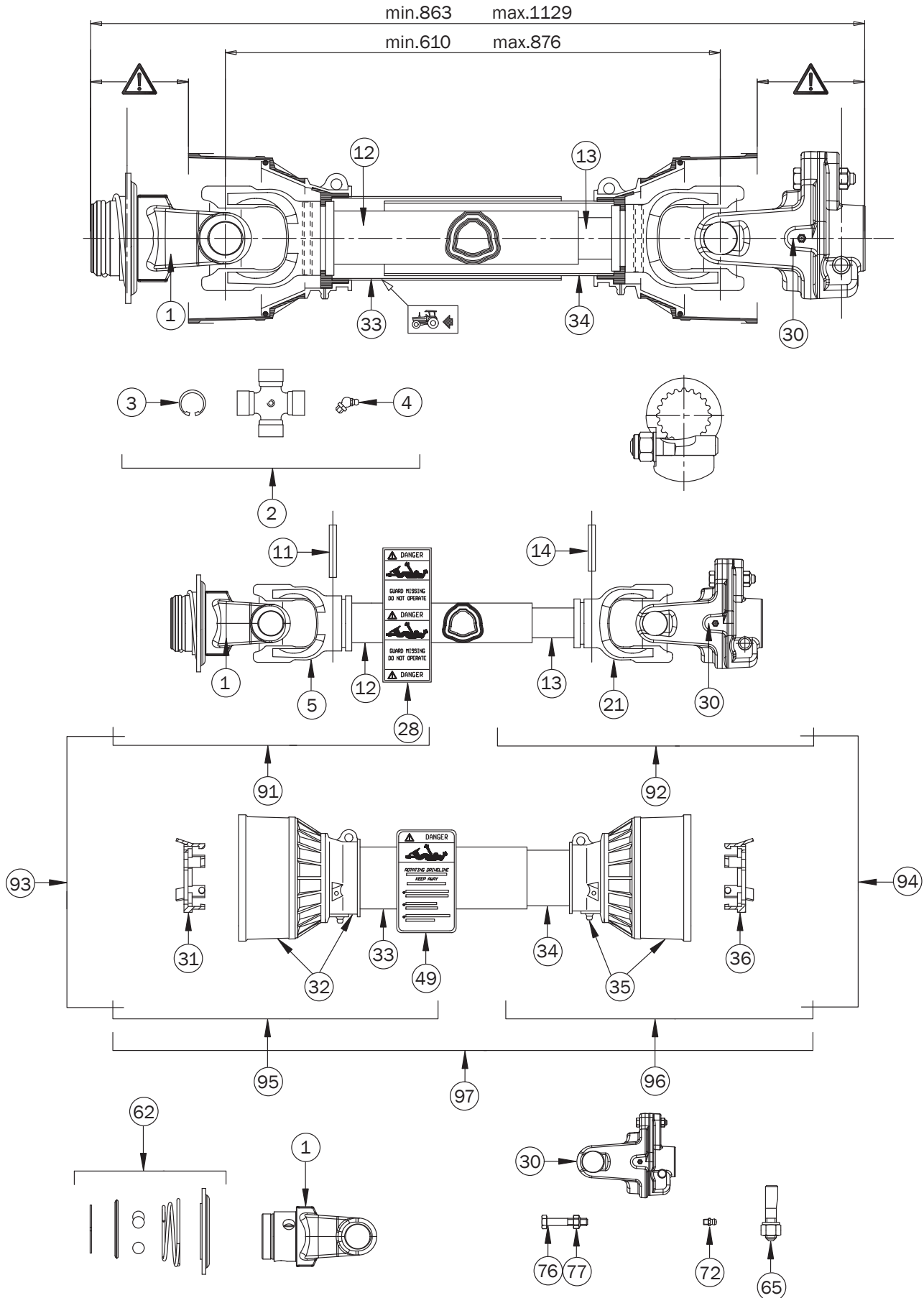

1000 RPM Drive Shaft - MC612C

Item No.	Stock No.	Description	Qty.
1	807965	Yoke	1
2	807967	Cross Journal Assembly	2
3	807968	Circlip	8
4	807970	Grease Zerk	2
5	807971	Outer Tube Yoke	1
11	808015	Flexible Pin	1
12	808017	Cardan Tube, Outer	1
13	808020	Cardan Tube, Inner	1
14	808021	Flexible Pin	1
21	808023	Inner Yoke Tube	1
28	808025	Label	1
30	808027	LB Torque Limiter Yoke Assembly	1
31	808029	Shield Supporter 8-9-0	1
32	808036	O. Cone Sets F5-6-7	1
33	808037	Safety Tube	1
34	808038	Safety Tube	1
35	808035	I. Cone Sets F5-6-7	1
36	808031	Shield Support 6-7	1
49	808026	Label	1
62	808042	Ball Collar Kit	1
65	808043	Pin/Nut	1
72	808064	Grease Nipple	1
76	807784	Bolt, 10 x 50mm (PTO Shear Bolt, 1000 RPM)	1
77	804189	10mm Nylon Locknut (1000 RPM)	1
91	808044	Outer Half Shaft	1
92	808047	Inner Half Shaft	1
93	808048	Outer Half Shaft Assembly	1
94	808051	Inner Half Shaft Assembly	1
95	808052	Outer Half Shaft Shield	1
96	808055	Inner Half Shaft Shield	1
97	808056	Complete Shield	1

Over-Running Clutch - MC617A

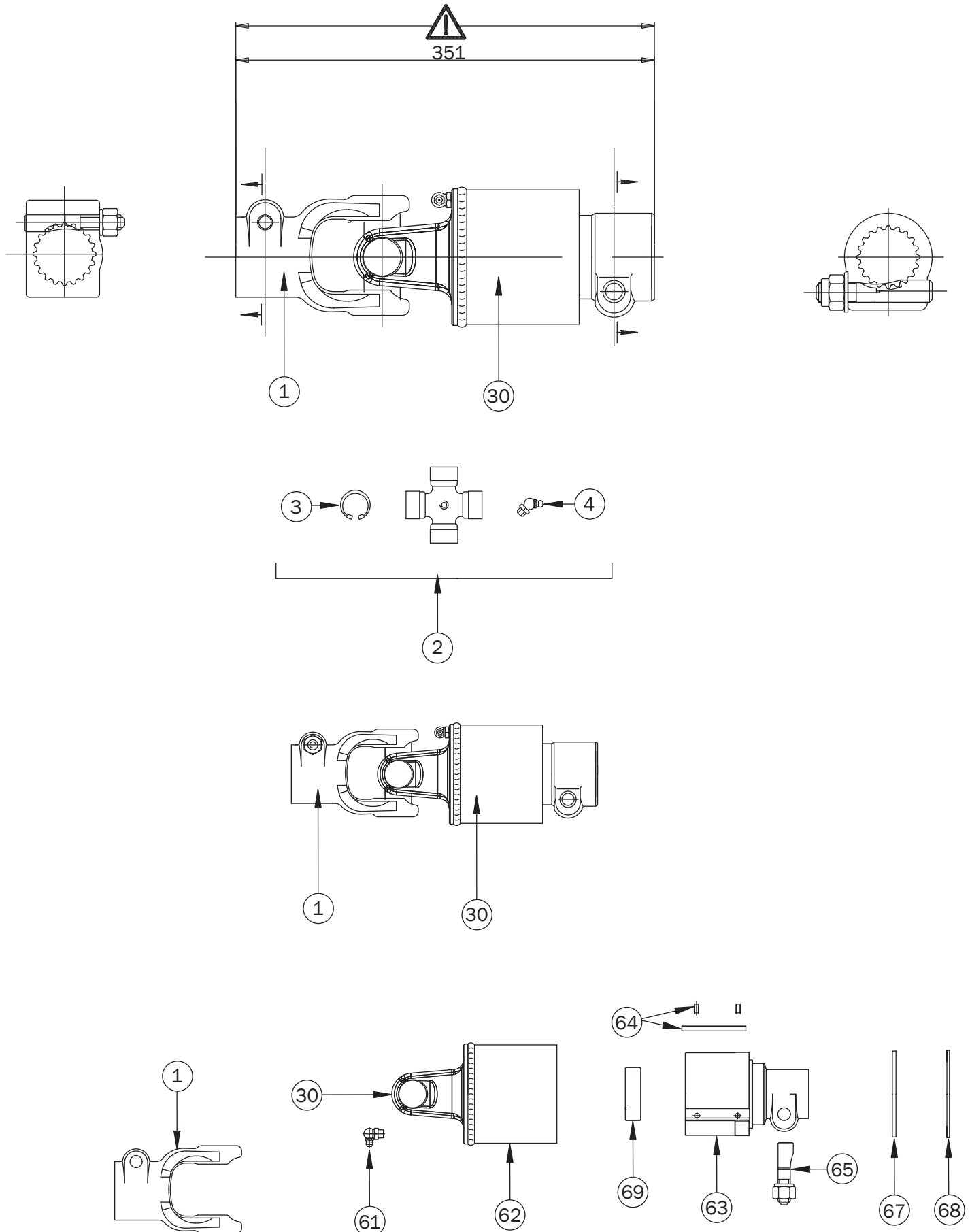

Over-Running Clutch - MC617A

Item No.	Stock No.	Description	Qty.
1	808068	Yoke, Size 8 C, Bolt 1-3/4" 20SP (017)	1
2	807966	Cross Journal Assembly	1
3	807969	Circlip	4
4	807970	Grease Zerk	2
30	808072	RA3/8 1-3/4" Z20 Taper Pin	1
61	808073	Grease Nipple	1
62	808070	Yoke & Outer Body	1
63	808074	Inner Part, Over-Run Clutch	1
64	808075	Kit	3
65	808067	Pin/Nut	2
67	808076	Half Disc	2
68	808077	Ring	1
69	808078	Ball Bearing 25 x 52 x 15 2RS 6205	1

Gearbox U-Joints - MC616A

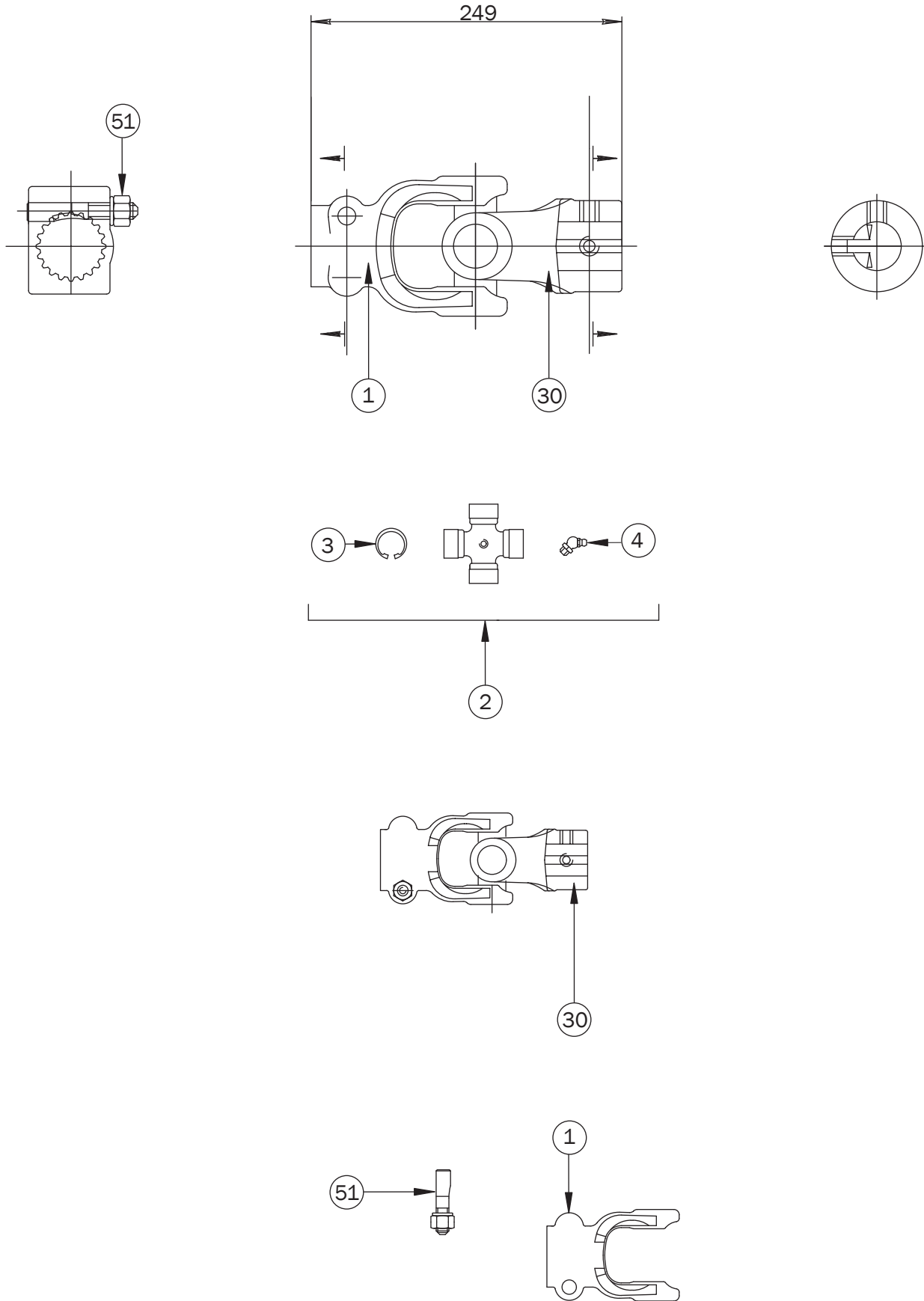

Gearbox U-Joints - MC616A

Item No.	Stock No.	Description	Qty.
1	808065	Yoke	1
2	807966	Cross Journal Assembly	1
3	807969	Circlip	4
4	807970	Grease Zerk	1
30	808066	Yoke	1
51	808067	Pin/Nut	1

Right Side - View A

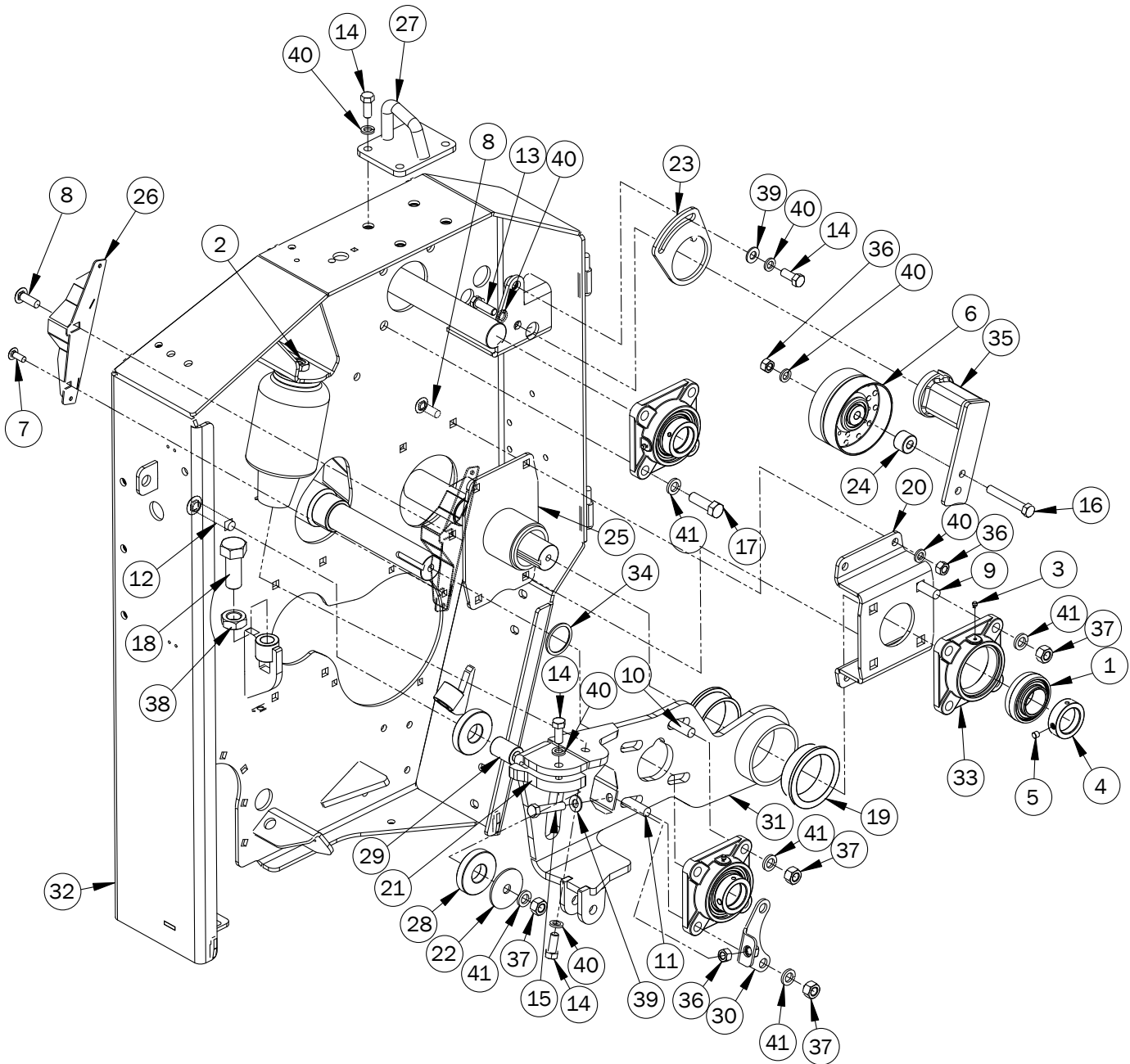

Right Side - View A

Item No.	Stock No.	Description	Qty.
1	800048	Bearing	3
2	804155	3/4" Nut, Jam, NF	1
3	807558	Nipple, Grease 1/4" NF	3
4	808109	Collar, Locking	3
5	808200	Screw, Set, 3/8" x 3/8"	3
6	808522	5" Idler Pulley	1
7	800057	3/8" x 1" Bolt, Carr. (See pages 38-39, Item 9)	-
8	800054	1/2" x 1-1/2" Bolt, Carr.	4
9	807517	5/8" x 1-3/4" Bolt, Carr.	4
10	800065	5/8" x 2" Bolt, Carr.	2
11	810550	5/8" x 2-1/4" Bolt, Carr.	2
12	800068	5/8" x 3-1/2" Bolt, Carr.	1
13	808362	12mm x 40mm Bolt, Metric	1
14	800166	1/2" x 1-1/4" Bolt, Standard	7
15	800170	1/2" x 2-1/2" Bolt, Standard, Full Thread	1
16	800174	1/2" x 3-1/2" Bolt, Standard	1
17	800212	5/8" x 2" Bolt, Standard	4
18	800187	1" x 2-1/2" Bolt, Standard, Full Thread	1
19	801484	Bushing, Steel Roll Pivot	2
20	803876	Bearing Bracket - Rubber Roll, R/H	1
21	807788	Spacer, Pivot Arm, Steel Roll, R/H	1
22	803884	2-3/4" Washer	1
23	807052	Bracket, Rubber Roll Belt Tightener	1
24	808530	Spacer	1
25	803902	Pivot Arm Holder, R/H	1
26	807031	Shield Anti-Wrapper, R/H	1
27	807591	Lifting Hook	1
28	810496	Washer, Guide	2
29	810497	Trunnion, Pivot Arm, Steel Roll	1
30	807738	Bracket, Belt Tightening, R/H	1
31	810524	Pivot Arm, Steel Roll, R/H	1
32	810388	Main Frame, R/H	1
33	807890	Housing, 4 Bolt	3
34	807778	Shim - Steel Roll (Optional)	-
35	808966	Tightener	1
36	804196	1/2" Nut, Standard	6
37	804198	5/8" Nut, Standard	9
38	800133	1" Nut, Jam	1
39	807524	1/2" SAE Washer, Flat	2
40	804367	1/2" Washer, Lock	13
41	804368	5/8" Washer, Lock	13

Right Side - View B

Item No.	Stock No.	Description	Qty.
1	800048	Bearing	2
2	801820	Pin, R, 1/8"	2
3	803583	Bearing	2

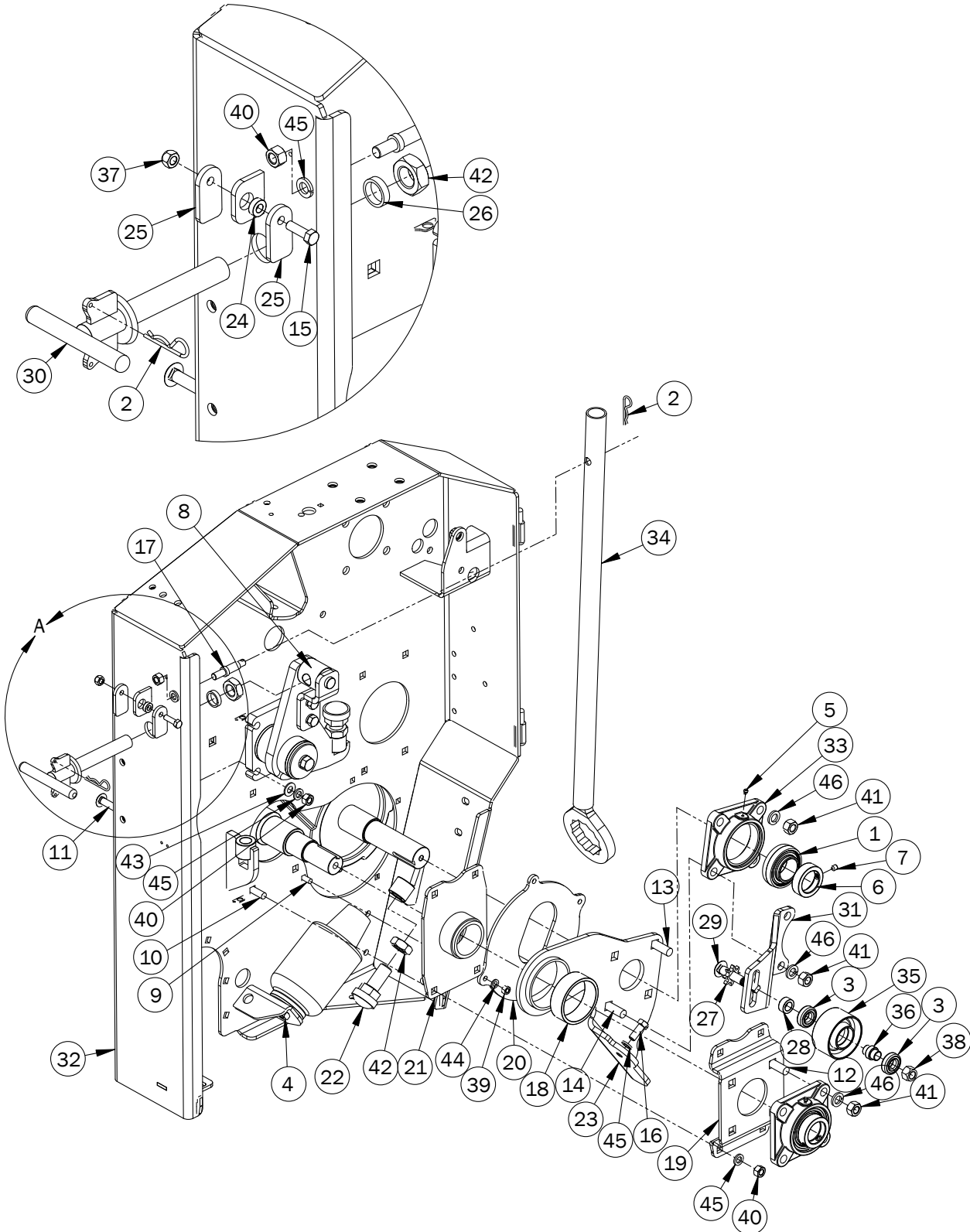

Right Side - View B

Item No.	Stock No.	Description	Qty.
4	804155	3/4" Nut, Jam, NF	1
5	807558	Nipple, Grease 1/4" NF	2
6	808109	Collar, Locking	2
7	808200	Screw, Set, 3/8" x 3/8"	2
8	803929r01	Gap Adjuster, R/H (See pages 52-53)	1
9	800057	3/8" x 1" Bolt, Carr.	4
10	800054	1/2" x 1-1/2" Bolt, Carr.	4
11	807706	1/2" x 1-3/4" Bolt, Carr.	4
12	807517	5/8" x 1-3/4" Bolt, Carr.	4
13	800065	5/8" x 2" Bolt, Carr.	2
14	810550	5/8" x 2-1/4" Bolt, Carr.	2
15	800197	3/8" x 1-1/4" Bolt, Standard	1
16	800166	1/2" x 1-1/4" Bolt, Standard	1
17	807884	Stud - Reversing Wrench Holder	1
18	801481	Pivot Bushing	1
19	803878	Roll Bearing Bracket	1
20	803895	Rubber Roll Cover	1
21	803904	Pivot Arm Holder	1
22	803908	Rubber Bumper	1
23	803915	Pivot Arm, Rubber Roll, R/H	1
24	803994	7mm Bushing 3/8" ID	1
25	804035r01	Crank Lock	2
26	804037	Crank Arm Spacing Bushing	1
27	804039r01	Belt Tightener Sprocket	1
28	804042r02	Spacer - Belt Tightener	1
29	807487	Bolt, Belt Tightener	1
30	804049r01	Rubber Bumper Crank	1
31	804050r02	Bracket, Belt Tightening	1
32	810388	Main Frame, R/H	1
33	807890	Housing, 4 Bolt	2
34	807028r01	Reversing Wrench	1
35	807456	Pulley - Idler - 3.5"	1
36	807457	Spindle - Idler	1
37	806636	3/8" Nut, Pinch Lock	1
38	807521	5/8" Nut, Pinch Lock	1
39	800236	3/8" Nut, Standard	4
40	804196	1/2" Nut, Standard	10
41	804198	5/8" Nut, Standard	8
42	800133	1" Nut, Jam	2
43	807524	1/2" SAE Washer, Flat	4
44	804366	3/8" Washer, Lock	4
45	804367	1/2" Washer, Lock	10
46	804368	5/8" Washer, Lock	8

Right Side - Drives

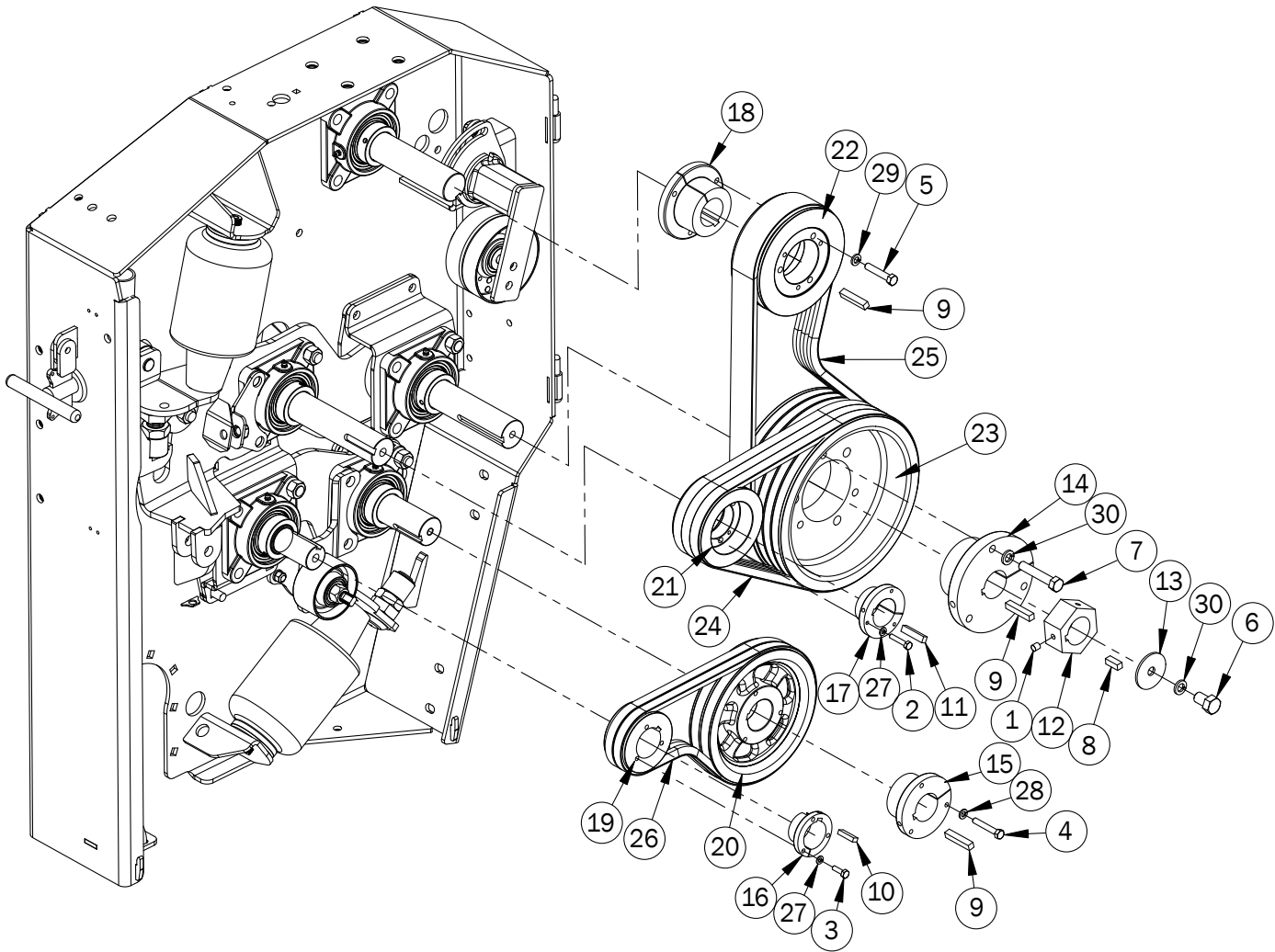

Right Side - Drives

Item No.	Stock No.	Description	Qty.
1	808200	Screw, Set, 3/8" x 3/8"	2
2	808341	1/4" x 1-3/8" Bolt, Standard, Full Thread	3
3	808342	1/4" x 7/8" Bolt, Standard, Full Thread	3
4	808343	5/16" x 2" Bolt, Standard, Full Thread	3
5	808340	3/8" x 2" Bolt, Standard, Full Thread	3
6	800164	1/2" x 1" Bolt, Standard	1
7	808339	1/2" x 2-3/4" Bolt, Standard, Full Thread	3
8	803661	3/8" x 1" Key	1
9	803662	3/8" x 2" Key	3
10	808344	3/8" x 1/4" x 1-1/4" Key	1
11	808345	3/8" x 5/16" x 1-3/4" Key	1
12	804116	Reversing Hex Block	1
13	807794	Washer - Hex Block	1
14	801169	Hub, E 1-3/4"	1
15	806941	Hub, SK 1-3/4"	1
16	806940	Hub, SH 1-1/2"	1
17	801176	Hub, SDS 1-3/4"	1
18	801177	Hub, SF 1-3/4"	1
19	806938	2B34 Pulley	1
20	806939	2B80 Pulley	1
21	804232	3-5V5.2 Pulley	1
22	804233	3-5V7.1 Pulley	1
23	804236	6-5V10.9 Pulley	1
24	802911	V-Belt, 5VX450	3
25	806942	V-Belt, 3-5VX630 Banded	1
26	802917	V-Belt, BX36	2
27	808353	1/4" Washer, Lock	6
28	807528	5/16" Washer, Lock	3
29	804366	3/8" Washer, Lock	3
30	804367	1/2" Washer, Lock	4

Left Side - View A

Item No.	Stock No.	Description	Qty.
1	800048	Bearing	3
2	803585	Bearing	1
3	803587	Bearing	1
4	804155	3/4" Nut, Jam, NF	1
5	807558	Nipple, Grease 1/4" NF	3

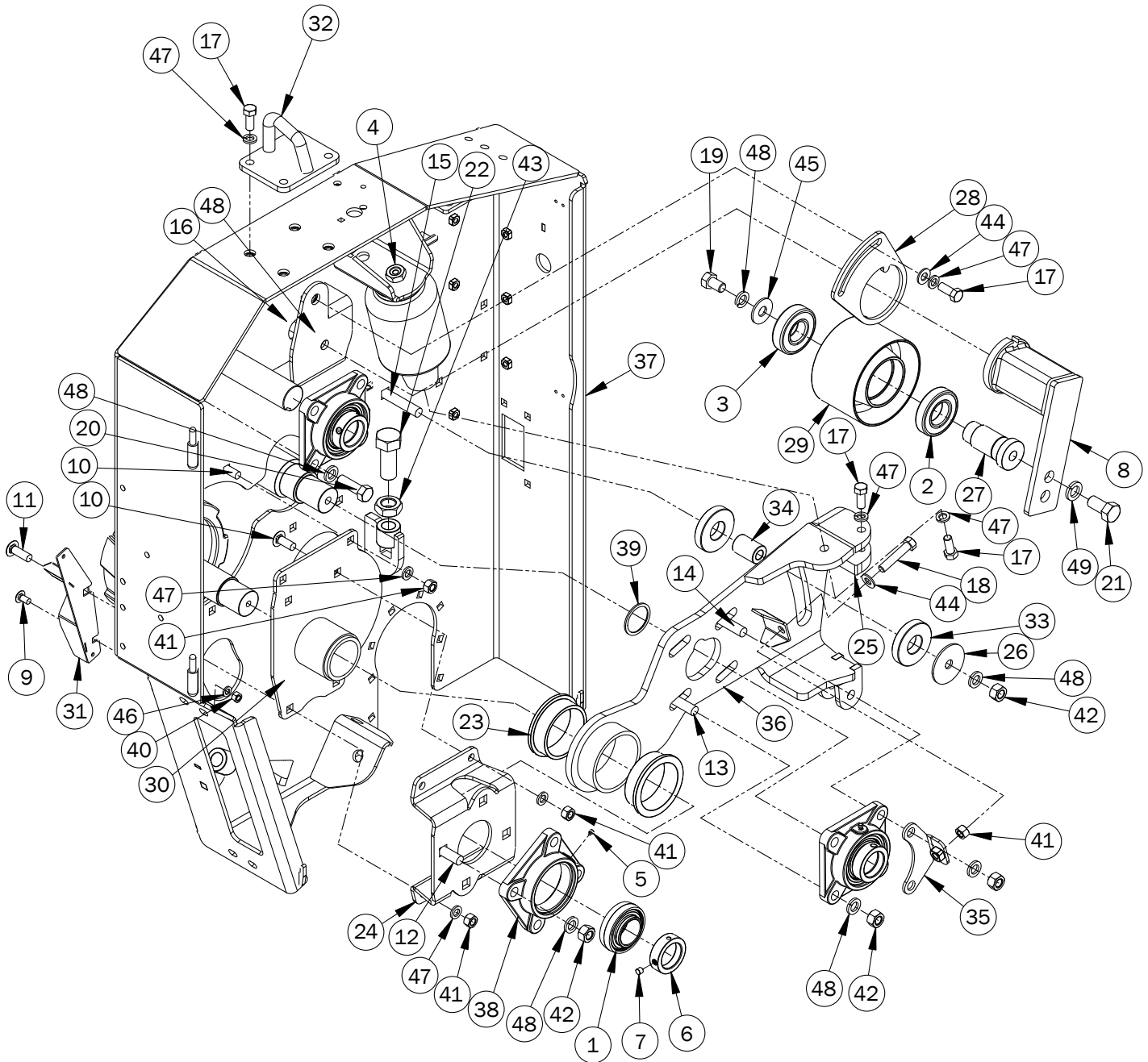

Left Side - View A

Item No.	Stock No.	Description	Qty.
6	808109	Collar, Locking	3
7	808200	Screw, Set, 3/8" x 3/8"	3
8	808965	Tightener	1
9	800061	3/8" x 3/4" Bolt, Carr.	1
10	800055	1/2" x 1-1/4" Bolt, Carr.	4
11	800054	1/2" x 1-1/2" Bolt, Carr.	2
12	807517	5/8" x 1-3/4" Bolt, Carr.	4
13	800065	5/8" x 2" Bolt, Carr.	2
14	810550	5/8" x 2-1/4" Bolt, Carr.	2
15	800068	5/8" x 3-1/2" Bolt, Carr.	1
16	808363	16mm x 40mm Bolt, Metric	1
17	800166	1/2" x 1-1/4" Bolt, Standard	7
18	800170	1/2" x 2-1/2" Bolt, Standard, Full Thread	1
19	800210	5/8" x 1" Bolt, Standard	1
20	808212	5/8" x 2" Bolt, Standard	4
21	800189	3/4" x 1-1/2" Bolt, Standard	1
22	800187	1" x 2-1/2" Bolt, Standard, Full Thread	1
23	801484	Bushing, Steel Roll Pivot	2
24	803874	Bearing Bracket, L/H, Rubber Roll	1
25	807786	Spacer, Pivot Arm, Steel Roll, L/H	1
26	803884	2-3/4" Washer	1
27	803892	Shaft - Steel Roll Drive Spindle	1
28	803894	Belt Tightener Holder	1
29	807461	Pulley - Idler - 6"	1
30	803906	Pivot Arm Holder, L/H	1
31	807032	Shield, Anti-Wrapper, L/H	1
32	807591	Lifting Hook	1
33	810496	Washer, Guide	2
34	810497	Trunnion, Pivot Arm, Steel Roll	1
35	807734	Bracket, Belt Tightening, L/H	1
36	810523	Pivot Arm, Steel Roll, L/H	1
37	810392	Main Frame, L/H	1
38	807890	Housing, 4 Bolt	3
39	807778	Shim - Steel Roll (Optional)	-
40	800236	3/8" Nut Standard	1
41	804196	1/2" Nut, Standard	7
42	804198	5/8" Nut, Standard	9
43	800133	1" Nut, Jam	1
44	807524	1/2" SAE Washer, Flat	2
45	804365	5/8" Washer, Flat	1
46	804366	3/8" Washer, Lock	1
47	804367	1/2" Washer, Lock	13
48	804368	5/8" Washer, Lock	15
49	804369	3/4" Washer, Lock	1

Left Side - View B

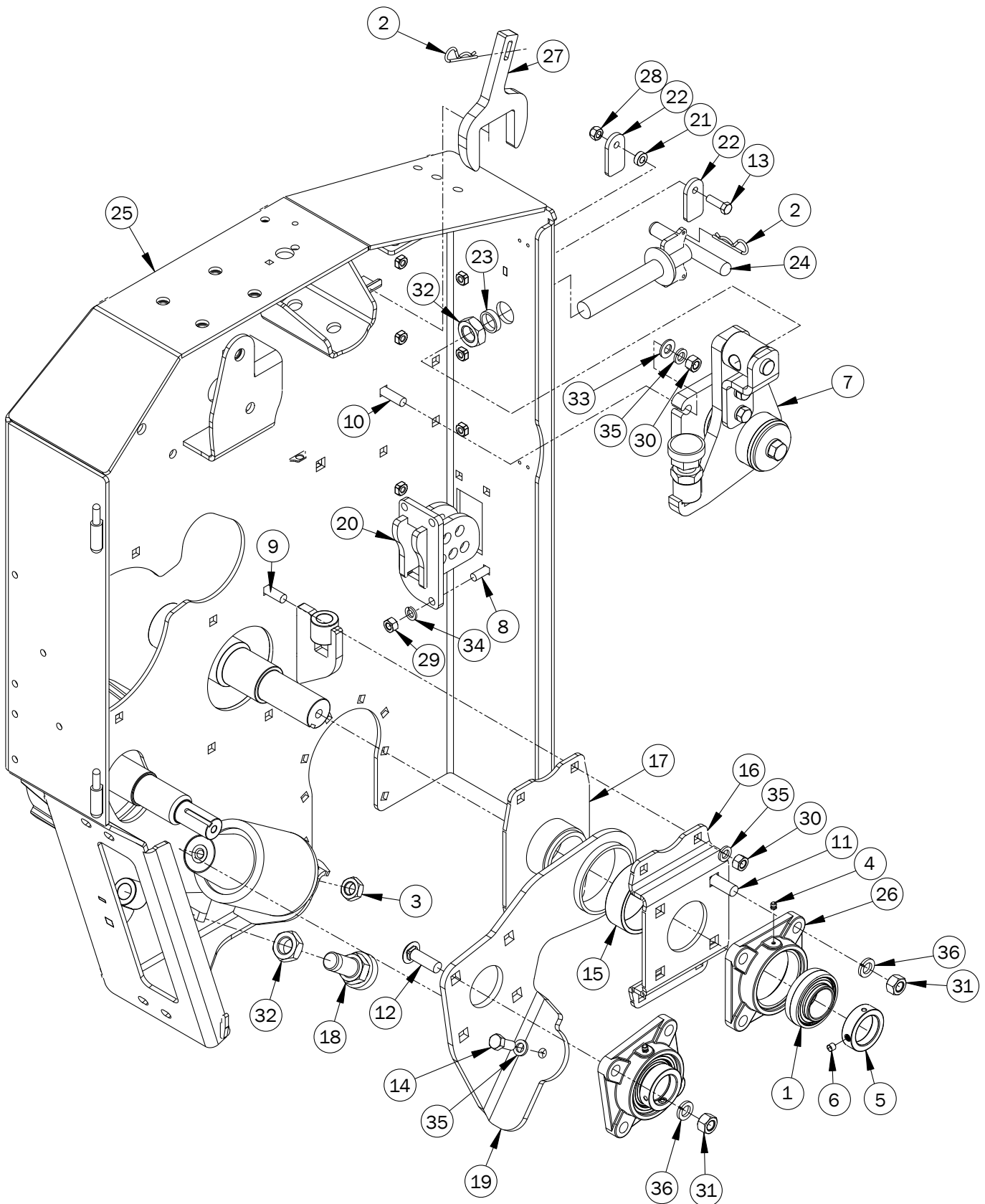

Left Side - View B

Item No.	Stock No.	Description	Qty.
1	800048	Bearing	2
2	801820	Pin, R, 1/8"	2
3	804155	3/4" Nut, Jam, NF	1
4	807558	Nipple, Grease 1/4" NF	2
5	808109	Collar, Locking	2
6	808200	Screw, Set, 3/8" x 3/8"	2
7	803927r01	Gap Adjuster, L/H (See pages 52-53)	1
8	800073	7/16" x 1-1/4" Bolt, Carr.	3
9	800054	1/2" x 1-1/2" Bolt, Carr.	4
10	807706	1/2" x 1-3/4" Bolt, Carr.	4
11	807517	5/8" x 1-3/4" Bolt, Carr.	4
12	800065	5/8" x 2" Bolt, Carr.	4
13	800197	3/8" x 1-1/4" Bolt, Standard	1
14	800166	1/2" x 1-1/4" Bolt, Standard	1
15	801481	Pivot Bushing	1
16	803878	Roll Bearing Bracket	1
17	803904	Pivot Arm Holder	1
18	803908	Rubber Bumper	1
19	803912	Rubber Roll Pivot Arm, L/H	1
20	803963r01	Height Adjuster Bracket	1
21	803994	7mm Bushing 3/8" ID	1
22	804035r01	Crank Lock	2
23	804037	Crank Arm Spacing Bushing	1
24	804049r01	Rubber Bumper Crank	1
25	810392	Main Frame, L/H	1
26	807890	Housing, 4 Bolt	2
27	804160	Torque Wrench	1
28	806636	3/8" Nut, Pinch Lock	1
29	800240	7/16" Nut, Standard	3
30	804196	1/2" Nut, Standard	8
31	804198	5/8" Nut, Standard	8
32	800133	1" Nut, Jam	2
33	807524	1/2" SAE Washer, Flat	4
34	806556	7/16" Washer, Lock	3
35	804367	1/2" Washer, Lock	9
36	804368	5/8" Washer, Lock	8

Left Side - Drives

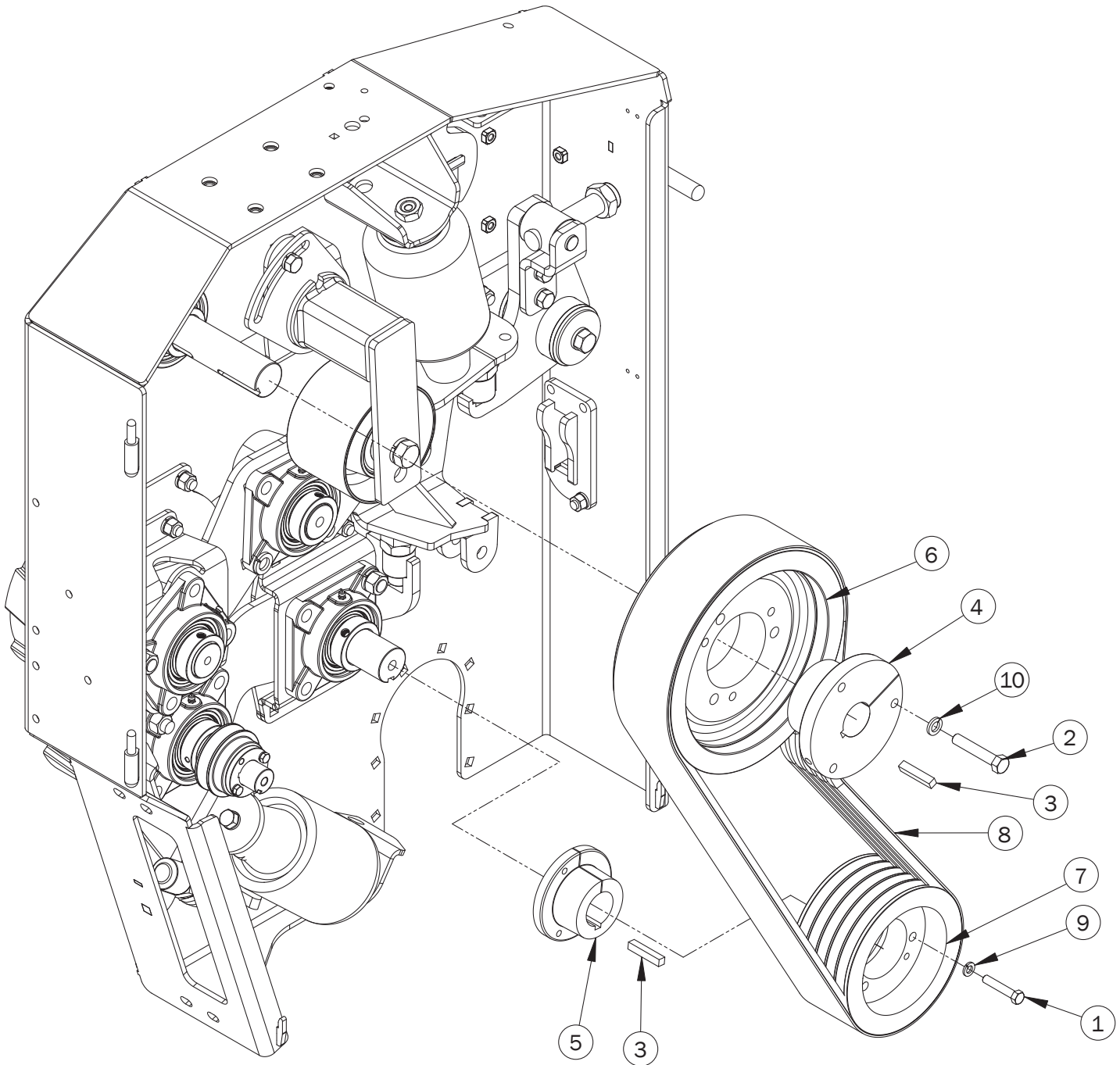

Left Side - Drives

Item No.	Stock No.	Description	Qty.
1	808340	3/8" x 2" Bolt, Standard, Full Thread	3
2	808339	1/2" x 2-3/4" Bolt, Standard, Full Thread	3
3	803662	3/8" x 2" Key	2
4	801169	Hub, E 1-3/4"	1
5	801177	Hub, SF 1-3/4"	1
6	804234	5-5V11.3 Pulley	1
7	804235	5-5V7.5 Pulley	1
8	806943	V-Belt, 5-5VX800 Banded	1
9	804366	3/8" Washer, Lock	3
10	804367	1/2" Washer, Lock	3

Lift Bracket Assembly - Right & Left Sides

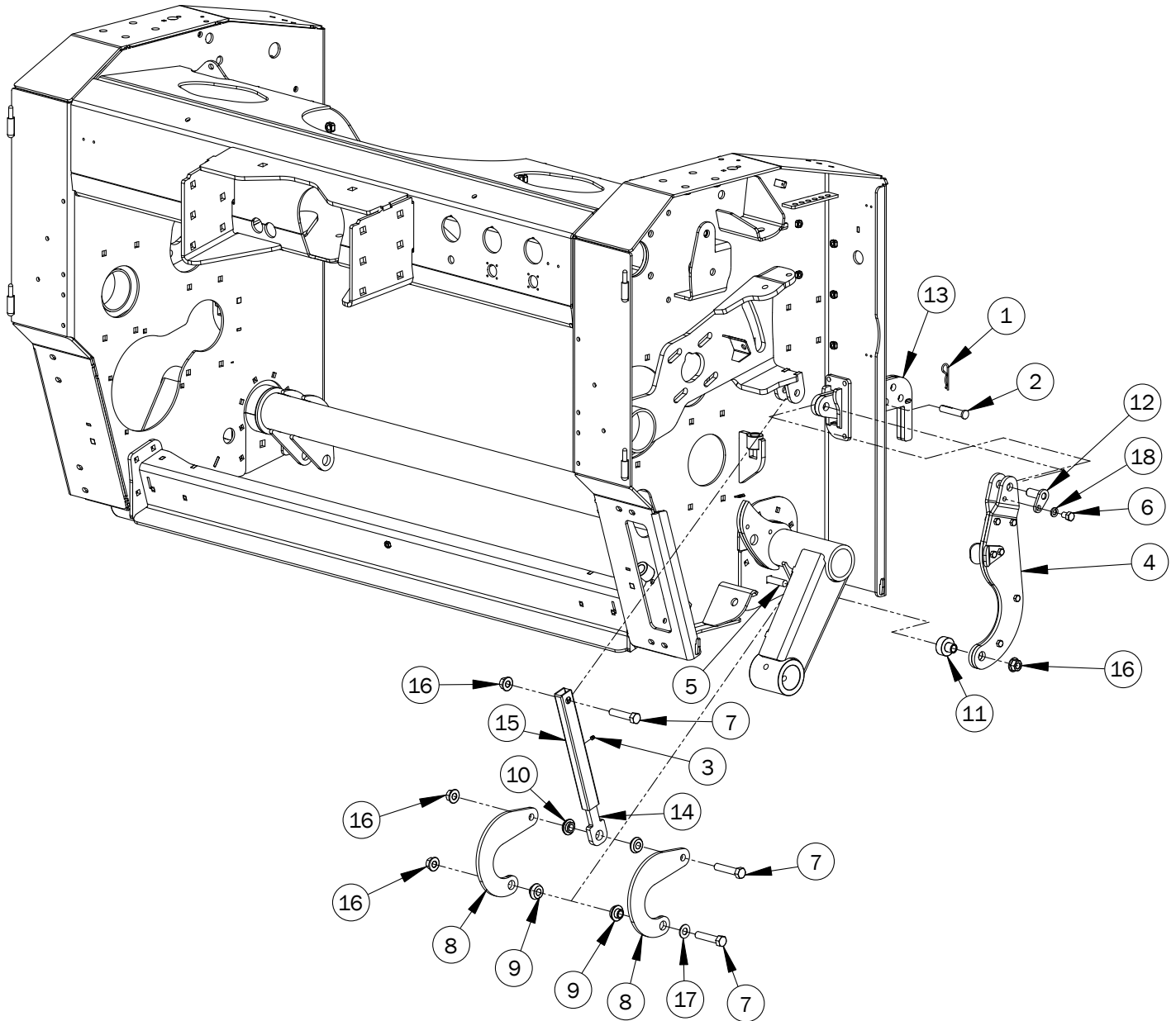

Lift Bracket Assembly - Right & Left Sides

Item No.	Stock No.	Description	Qty.
1	801820	Pin, R, 1/8"	1
2	807055	Pin, Clevis	1
3	807558	Nipple, Grease 1/4" NF	2
4	803947	Arm, Height Adjuster (See pages 50-51)	1
5	800066	5/8" x 2-1/2" Bolt, Carr.	1
6	800173	1/2" x 3/4" Bolt, Standard	1
7	800214	5/8" x 3" Bolt, Standard	6
8	803939	Bracket, Lift, Roll	4
9	803938r01	Lift Bracket Bushing	4
10	803941r01	Lift Arm Bushing	4
11	803951	Bushing, Spacer, Height Adjuster	1
12	803962	Height Adjuster Arm Pin	1
13	803966r02	Height Adjuster Bar	1
14	810536	Insert, Roll Lift Arm	2
15	810531	Tube, Roll Lift Arm	2
16	804187	5/8" Nut, Flange Pinch Lock	7
17	807525	5/8" SAE Washer, Flat	2
18	804367	1/2" Washer, Lock	1

Height Adjuster

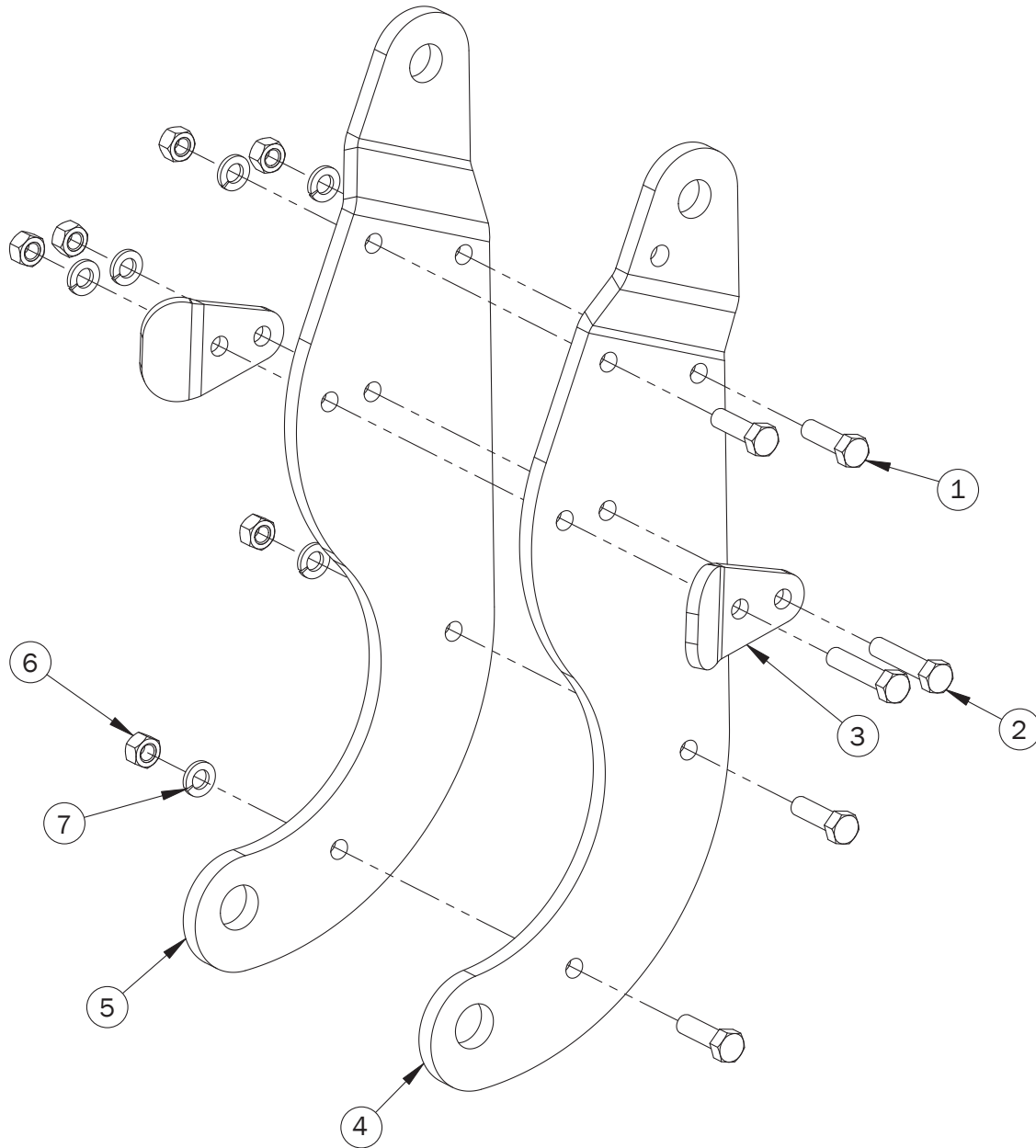

Height Adjuster

Item No.	Stock No.	Description	Qty.
1	800197	3/8" x 1-1/4" Bolt, Standard	4
2	800198	3/8" x 1-3/4" Bolt, Standard	2
3	803950	Guide	2
4	803953	Height Adjuster Arm, L/H	1
5	803955	Height Adjuster Arm, R/H	1
6	800236	3/8" Nut, Standard	6
7	804366	3/8" Washer, Lock	6

Gap Adjusters

Gap Adjuster - Right Side

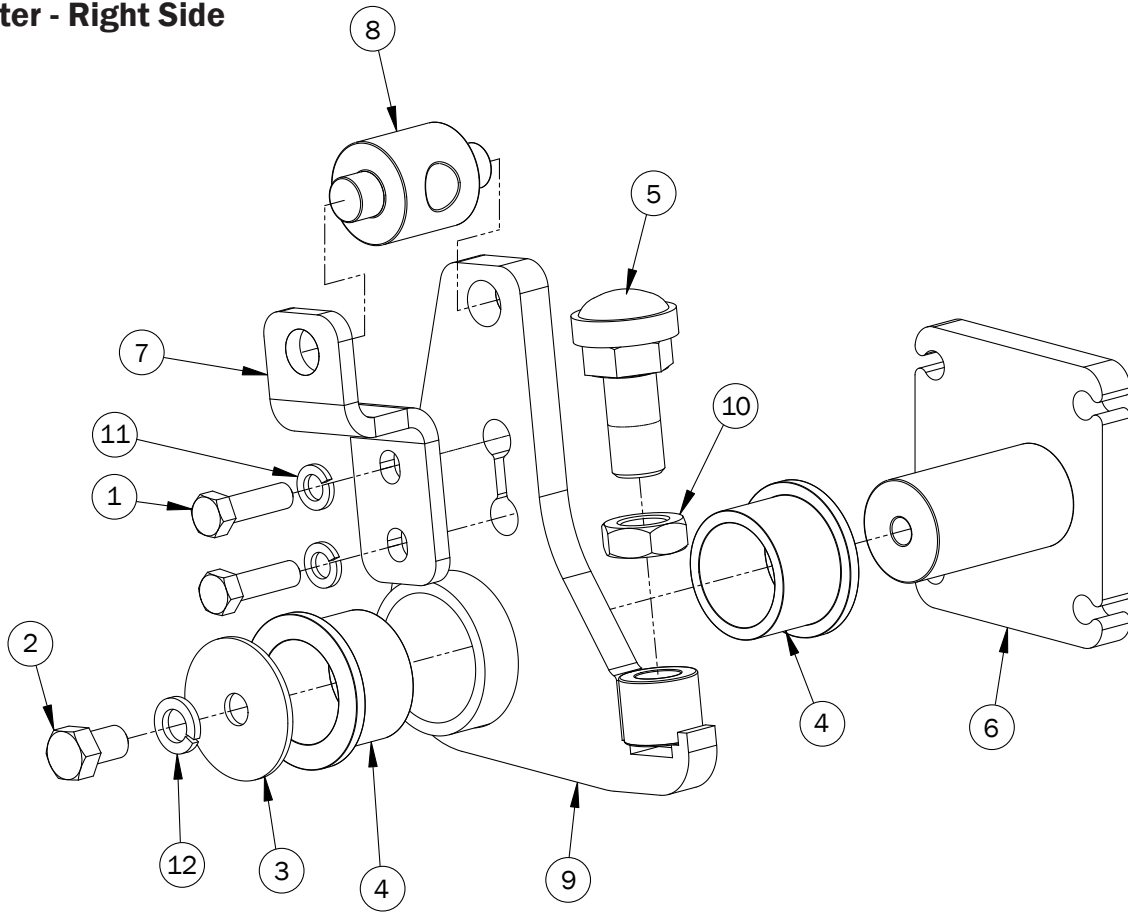

Gap Adjuster - Left Side

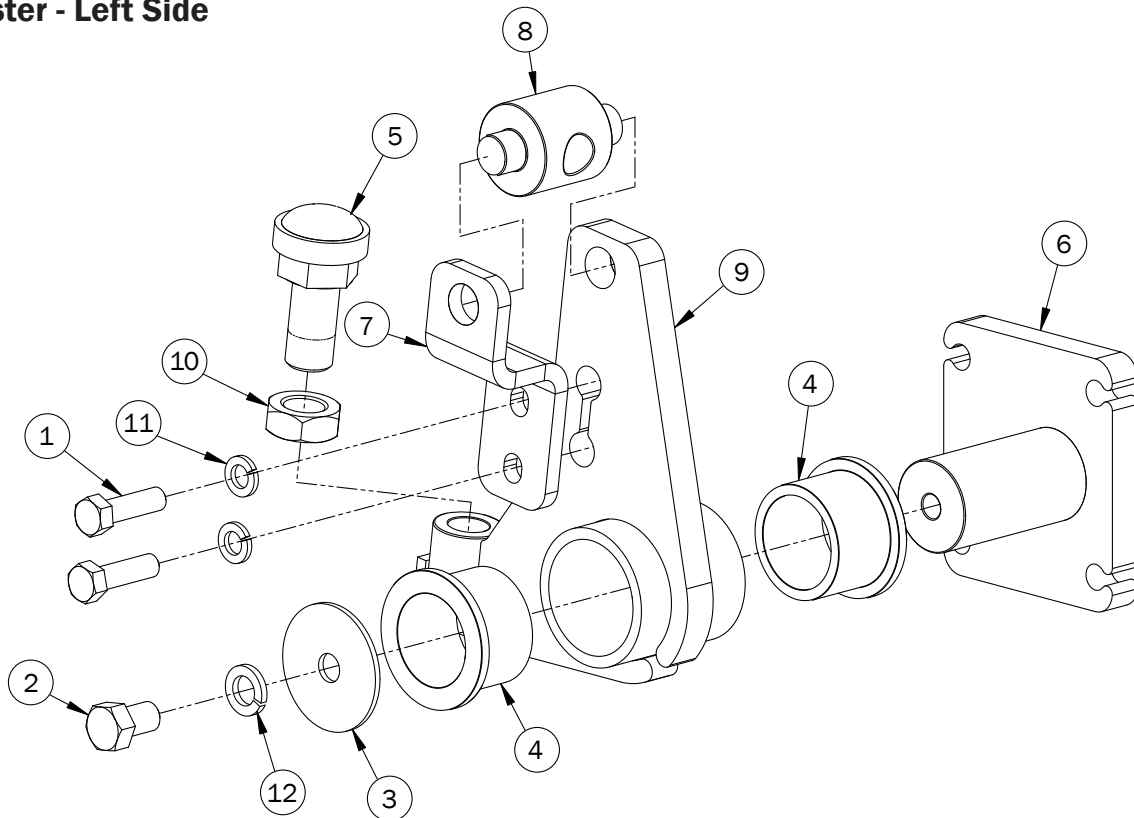

Gap Adjusters

Gap Adjuster - Right Side

Item No.	Stock No.	Drawing No.	Description	Qty.
1	800167	BOS32075	1/2" x 1-3/4" Bolt, Standard	2
2	800210	BOS40045	5/8" x 1" Bolt, Standard	1
3	803884	MC225A	2-3/4" Washer	1
4	801518	MC228A	Rubber Bumper Pivot, Bushing	2
5	803908	MC22W3	Rubber Bumper	1
6	803928	MC22W9	Pivot, Rubber Bumper	1
7	810416	MC237C	Holder, Swivel Nut	1
8	810418	MC237D	Swivel Nut, Rubber Bumper Adjuster	1
9	810412	MC23W7R	Pivot, Rubber Bumper, R/H	1
10	800133	NUTSJ64	1" Nut, Jam	1
11	804367	WAL32	1/2" Washer, Lock	2
12	804368	WAL40	5/8" Washer, Lock	1

Gap Adjuster - Left Side

Item No.	Stock No.	Description	Qty.
1	800167	1/2" x 1-3/4" Bolt, Standard	2
2	800210	5/8" x 1" Bolt, Standard	1
3	803884	2-3/4" Washer	1
4	801518	Rubber Bumper Pivot, Bushing	2
5	803908	Rubber Bumper	1
6	803928	Pivot, Rubber Bumper	1
7	810416	Holder, Swivel Nut	1
8	810418	Swivel Nut, Rubber Bumper Adjuster	1
9	810410	Pivot, Rubber Bumper, L/H	1
10	800133	1" Nut, Jam	1
11	804367	1/2" Washer, Lock	2
12	804368	5/8" Washer, Lock	1

Axle Assembly

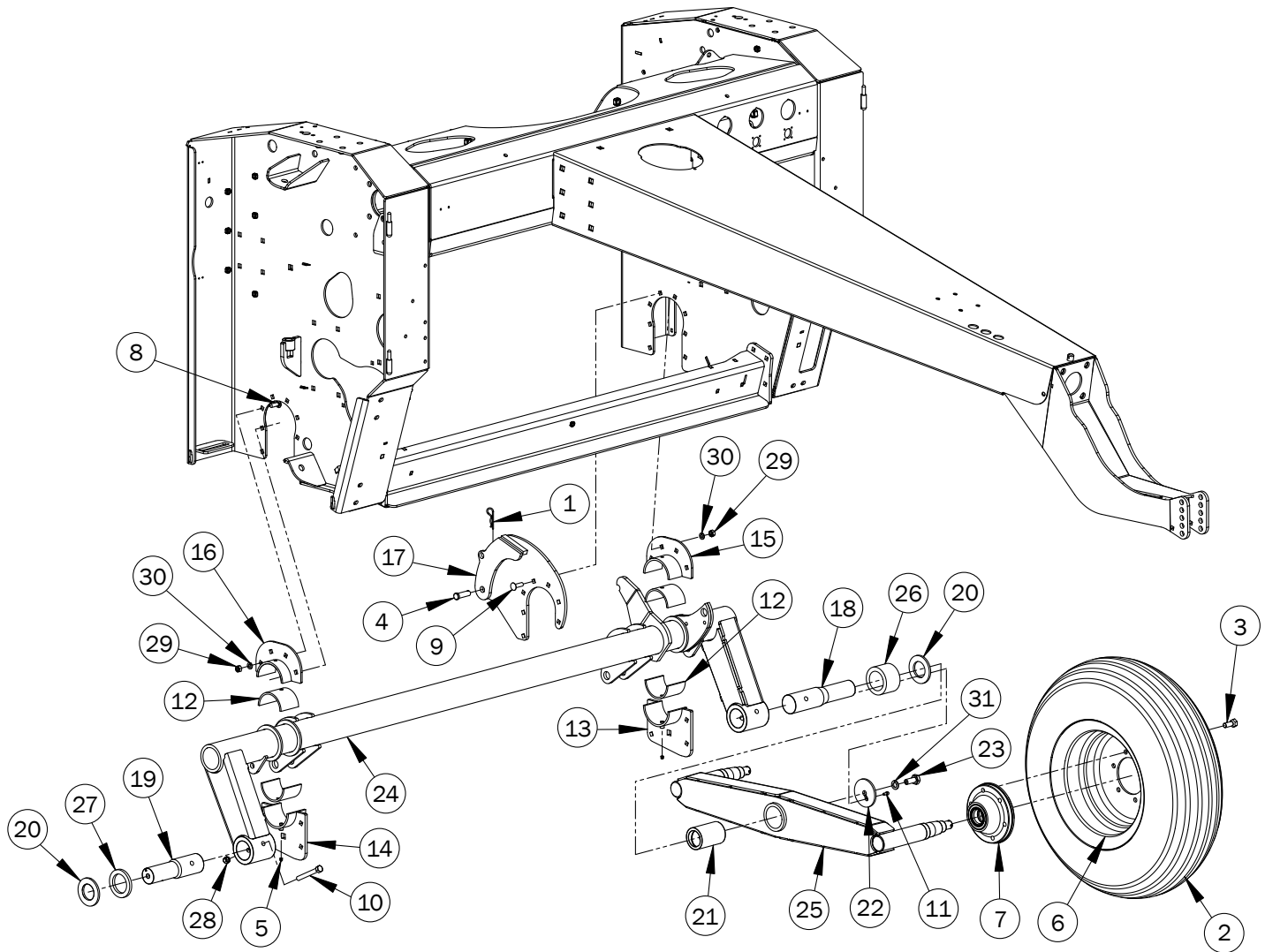

Axle Assembly

Item No.	Stock No.	Description	Qty.
1	801820	Pin, R, 1/8"	1
2	804067	Wheel (Tire, Rim, and Valve)	4
3	804078	Wheel Bolt	24
4	804111	Pin, Travel Safety	1
5	807558	Nipple, Grease 1/4" NF	2
6	808115	Rim	4
7	808587	Wheel Hub Assembly (See pages 56-57)	4
8	800073	7/16" x 1-1/4" Bolt, Carr.	9
9	800072	7/16" x 1-1/2" Bolt, Carr.	7
10	800176	1/2" x 4" Bolt, Standard	2
11	807757	1/4" x 1/2" Cap Screw, Socket Head	2
12	801471r01	Axle Bushing	4
13	803851r01	Axle Support, L/H, Bottom	1
14	803853r01	Axle Support, R/H, Bottom	1
15	803865r01	Axle Seat, L/H, Top	1
16	803867r01	Axle Seat, R/H, Top	1
17	803871	Travel Safety Bracket	1
18	810407	Pivot Shaft, Walking Beam, Axle, L/H	1
19	810408	Pivot Shaft, Walking Beam, Axle, R/H	1
20	810406	Washer, Pivot Shaft, Walking Beam, Axle	2
21	801538r02	Bushing, Walking Beam	2
22	803946r01	Washer, Walking Beam	2
23	807000	Axle Grease Bolt	2
24	810398	Axle	1
25	803959	Walking Beam	2
26	810420	Spacer, Walking Beam, Axle, L/H	1
27	810422	Spacer, Walking Beam, Axle, R/H	1
28	810649	1/2" Nut, Pinch Lock	2
29	800240	7/16" Nut, Standard	16
30	806556	7/16" Washer, Lock	16
31	804368	5/8" Washer, Lock	2

Wheel Hub Assembly

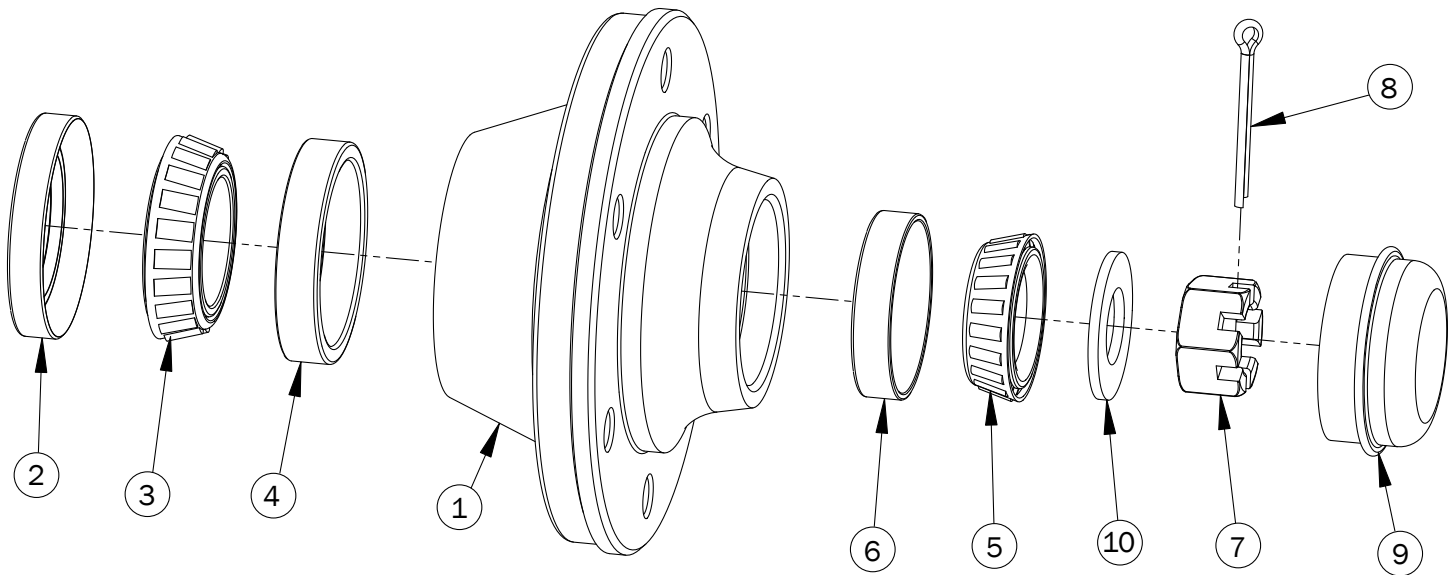

Wheel Hub Assembly

Item No.	Stock No.	Description	Qty.
1	804069	Wheel Hub/Race	1
2	804070	Oil Seal	1
3	804071	Bearing	1
4	807822	Race	1
5	804073	Bearing	1
6	807821	Race	1
7	804075	Nut	1
8	804076	Cotter Pin	1
9	804077	Hub Cap	1
10	804080	Washer	1

Hydraulics

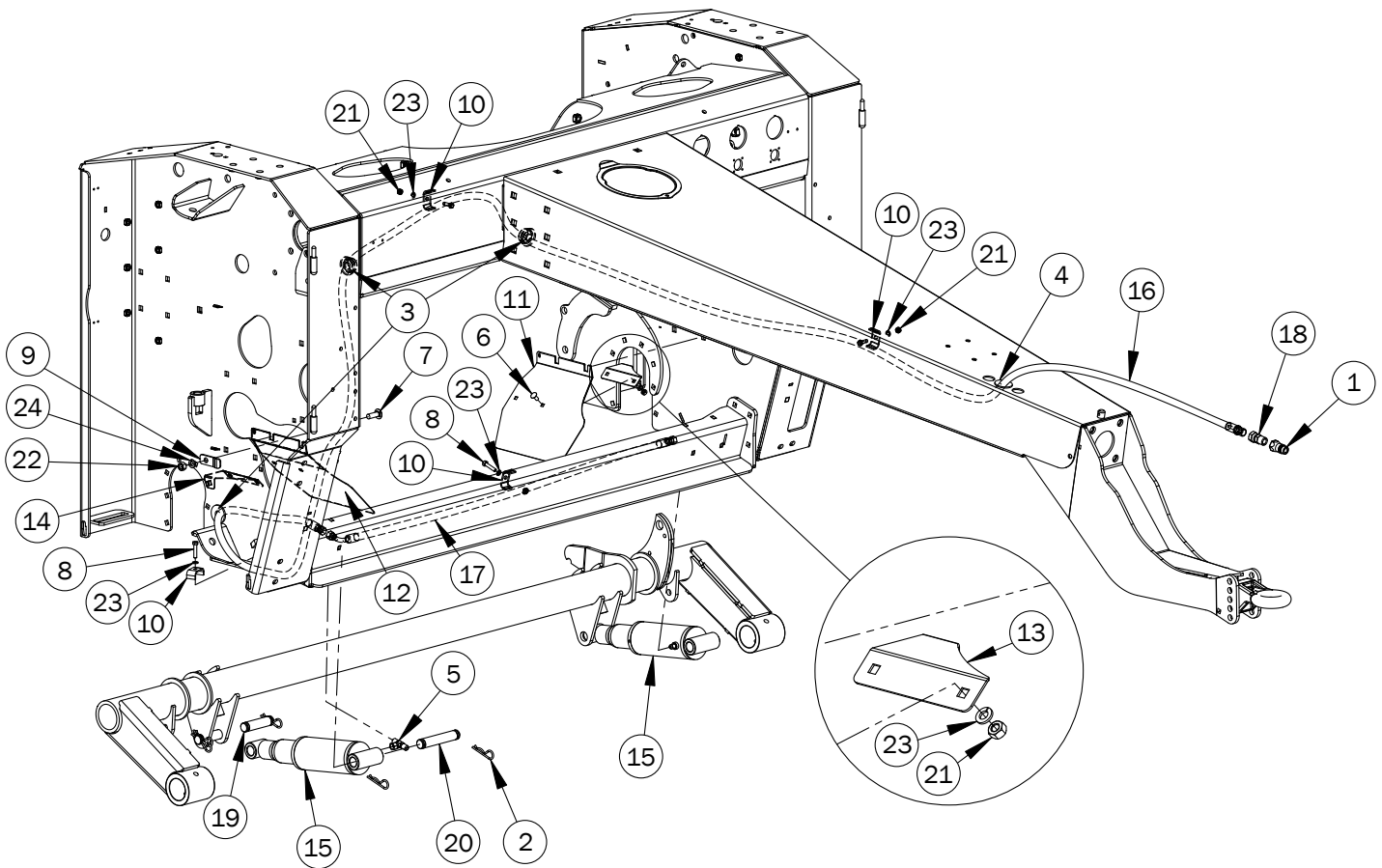

Hydraulics

Item No.	Stock No.	Description	Qty.
1	804099	Quick Coupler	1
2	804103	Pin, Hitch, R, 5/32" x 2-15/16"	8
3	804105	Grommet	3
4	804106	Grommet	1
5	807452	Tee # 6 JIC	1
6	800062	5/16" x 3/4" Bolt, Carr.	4
7	800054	1/2" x 1-1/2" Bolt, Carr. (See pages 36-37, Item 8)	-
8	800205	5/16" x 1-1/2" Bolt, Standard	2
9	803795	Hose Clamp	1
10	803829	Hydraulic Hose Clamp	4
11	807639	Shield, Cylinder, L/H	1
12	807642	Shield, Cylinder, R/H	1
13	810432	Brace, Shield, Cylinder, L/H	1
14	810435	Brace, Shield, Cylinder, R/H	1
15	807445	Cylinder Assembly (See pages 60-61)	2
16	807449	Hydraulic Hose - Long	1
17	807451	Hydraulic Hose - Short	1
18	807705	Flow Restrictor	1
19	804101	Cylinder Pin, 3-1/4"	2
20	804102	Cylinder Pin, 4-3/4"	2
21	804194	5/16" Nut, Standard	6
22	804196	1/2" Nut, Standard (See pages 36-37, Item 36)	-
23	807528	5/16" Washer, Lock	8
24	804367	1/2" Washer, Lock (See pages 36-37, Item 40)	-

Cylinder Assembly

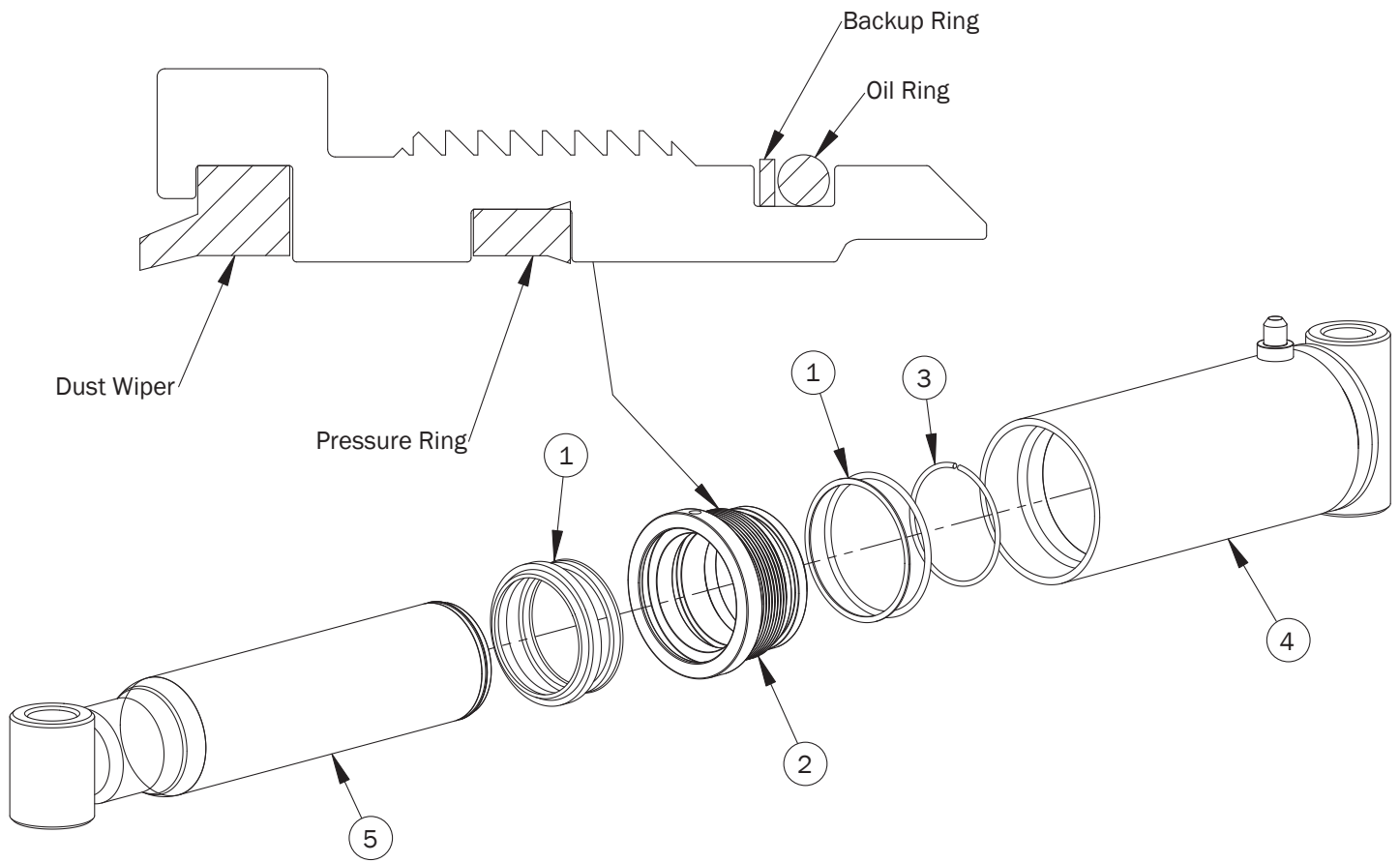

Cylinder Assembly

Item No.	Stock No.	Description	Qty.
1	807355	Seal Kit, Cylinder	1
2	807633	Nut, Cylinder	1
3	807356	Retaining Snap Ring	1
4	807635	Tube, Cylinder	1
5	807634	Shaft, Cylinder	1

Air System

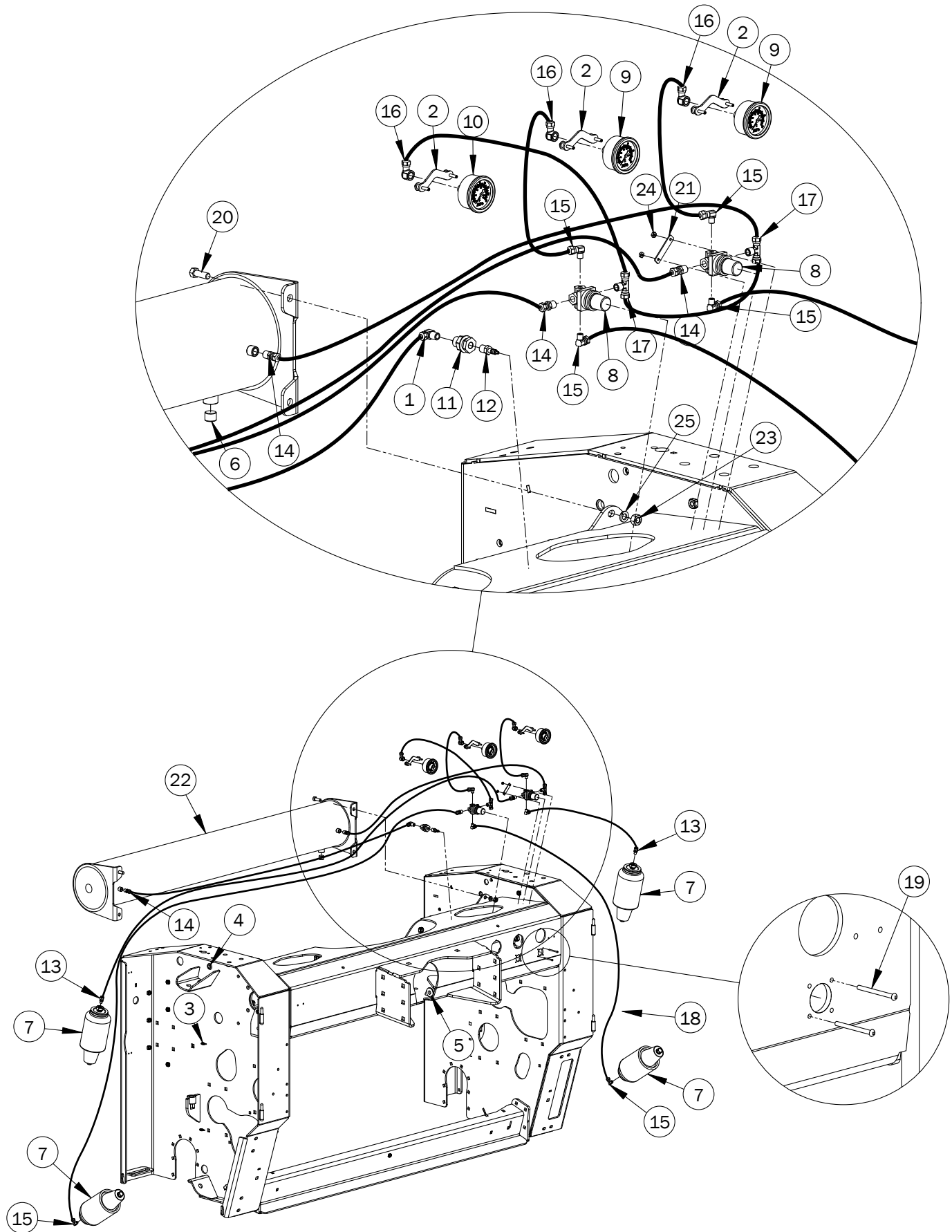

Air System

Item No.	Stock No.	Description	Qty.
1	800755	1/4" Compression x 1/4" Male Pipe Thread Elbow	1
2	801714	Clamp, U, Gauge	3
3	804107	Grommet	4
4	804108	Grommet	8
5	804109	Grommet	9
6	804142	Plug, 1/2" NPT	1
7	804143	Air Bag	4
8	804144	Regulator	2
9	804146	Gauge, Roll Pressure	2
10	804147	Gauge, Air Tank Pressure	1
11	804148	Bulkhead Fitting	1
12	804149	Shrader Valve	1
13	804150	Straight Fitting, 1/8" x 1/4"	2
14	804151	Straight Fitting, 1/4" x 1/4"	4
15	804152	1/8" Male x 1/4" Hose End Elbow	6
16	804153	1/4" Female End x 1/4" Hose End Elbow	3
17	804154	Tee	2
18	808623	Green Tubing 1/4" (For whole machine.)	35.5ft
19	810773	8-32 x 2" Screw	4
20	803625	7/16" x 1-1/4" Bolt, Standard	4
21	810772	Clamp, Air Regulator	2
22	810494	Air Tank	1
23	800240	7/16" Nut, Standard	4
24	800143	8-32 Nut, Machine	4
25	806556	7/16" Washer, Lock	4

Lights & Emblem Assembly

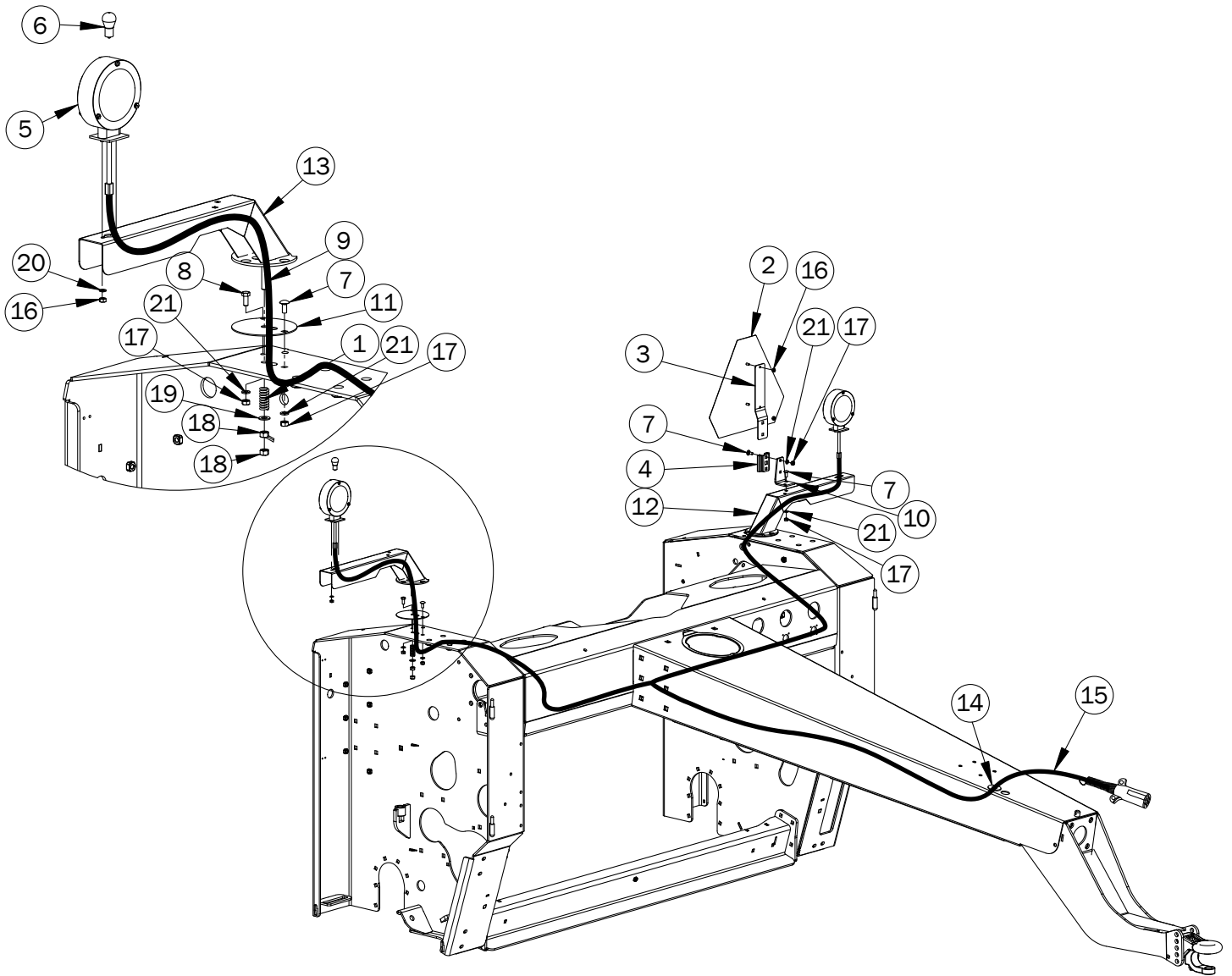

Lights & Emblem Assembly

Item No.	Stock No.	Description	Qty.
1	804302	Compression Spring	2
2	807712	SMV Emblem Triangle	1
3	807713	SMV Emblem Bracket, 2" x 11"	1
4	807919	SMV Emblem Bracket, 2" x 2-1/2"	1
5	808262	Light Assembly	2
6	808267	Bulb	2
7	800062	5/16" x 3/4" Bolt, Carr.	6
8	800209	5/16" x 3/4" Bolt, Standard	2
9	800200	3/8" x 2-1/2" Bolt, Standard	2
10	807802	Bracket - SMV Emblem	1
11	804032	Light Bracket, Pivot Wear Plate	2
12	804044r02	Light Bracket, L/H	1
13	808381	Light Bracket, R/H	1
14	804106	Grommet	1
15	801732	Wire Harness (With plug-ins complete.)	1
16	800233	1/4" Nut, Standard	6
17	804194	5/16" Nut, Standard	8
18	800236	3/8" Nut, Standard	4
19	807523	3/8" SAE Washer, Flat	2
20	808353	1/4" Washer, Lock	4
21	807528	5/16" Washer, Lock	8

Attachment Brackets

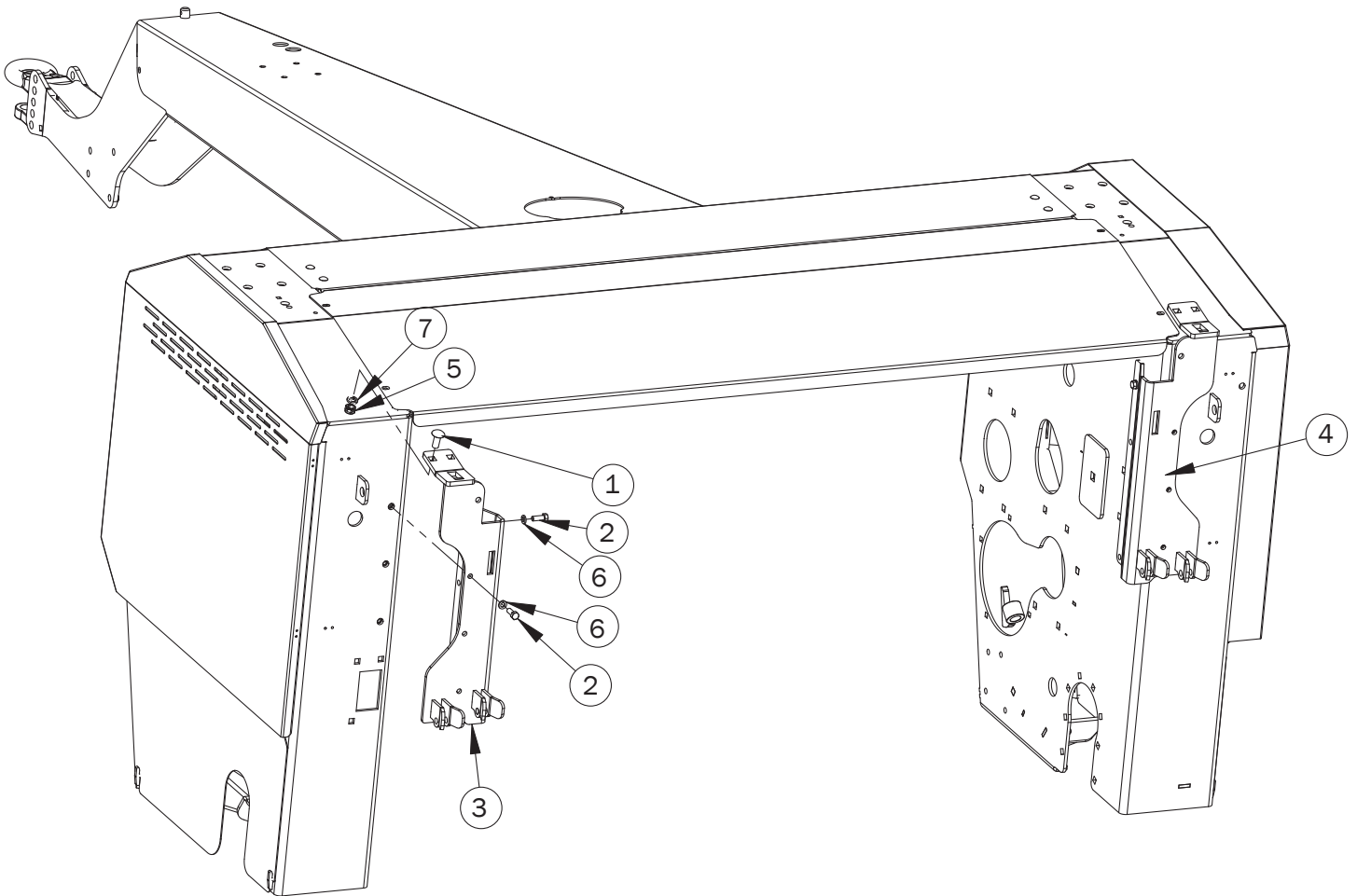

Attachment Brackets

Item No.	Stock No.	Description	Qty.
1	800055	1/2" x 1-1/4" Bolt, Carr.	4
2	800195	3/8" x 1" Bolt, Standard	14
3	807828	Tedder Quick Attach Hook Eye, L/H	1
4	807830	Tedder Quick Attach Hook Eye, R/H	1
5	804196	1/2" Nut, Standard	4
6	804366	3/8" Washer, Lock	14
7	804367	1/2" Washer, Lock	4

Windrower Attachment Kit K101

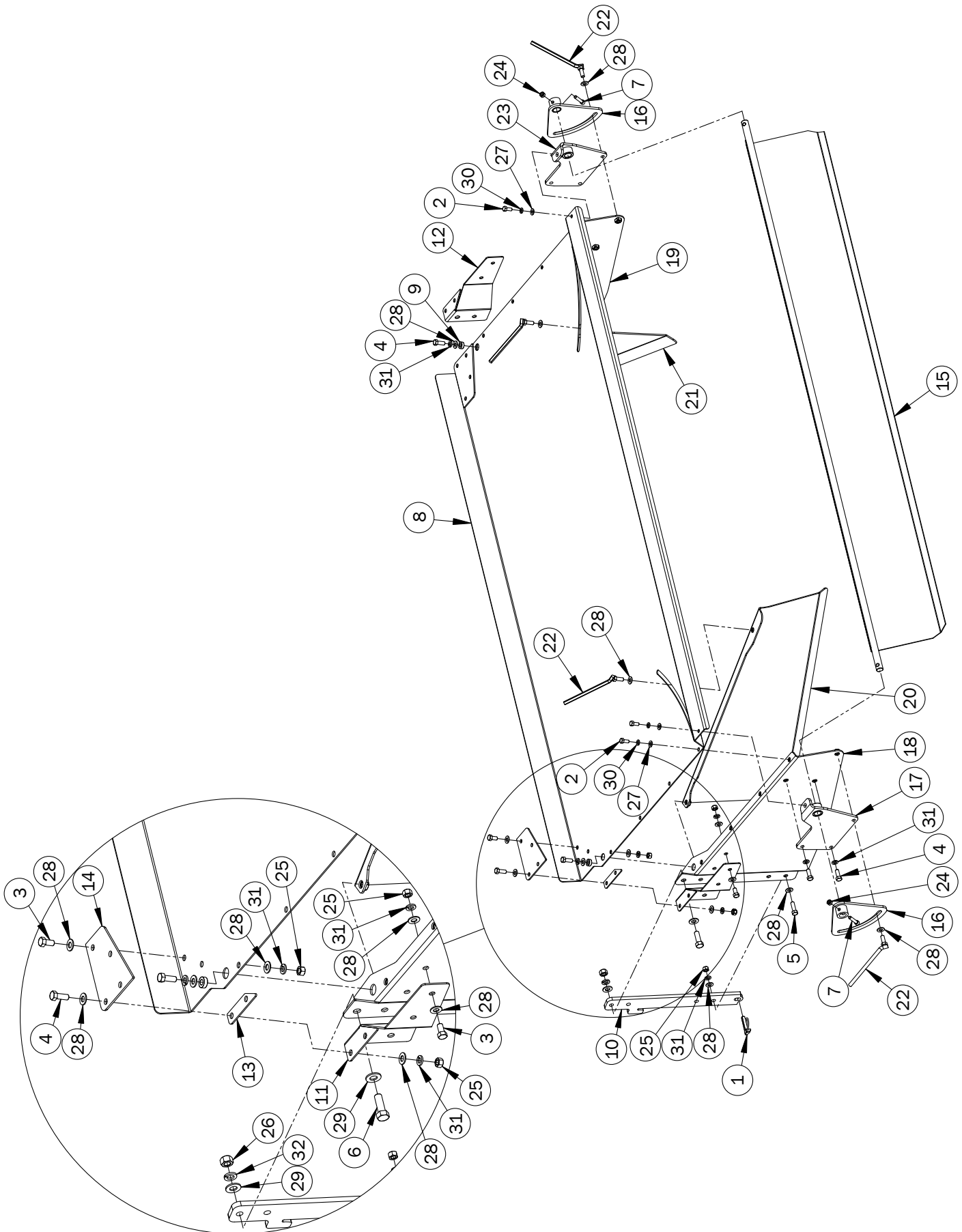

Windrower Attachment Kit K101

Item No.	Stock No.	Description	Qty.
1	801818	Pin, Lynch, 7/16"	2
2	800209	5/16" x 3/4" Bolt, Standard	10
3	803623	3/8" x 3/4" Bolt, Standard	8
4	800195	3/8" x 1" Bolt, Standard	10
5	800197	3/8" x 1-1/4" Bolt, Standard	6
6	800165	1/2" x 1-1/2" Bolt, Standard	2
7	800225	5/16" x 1-1/2" Cap Screw, Socket Head	2
8	803998	Top, Windrower	1
9	803994	7mm Bushing 3/8" ID	2
10	803996	Hook, Attachment	2
11	810636	Brace, Windrower, L/H	1
12	810633	Brace, Windrower, R/H	1
13	810621	Spacer, Windrower,	2
14	810622	Plate, Reinforcement, Windrower	2
15	804000	Chute Adjuster Plate	1
16	804002	Chute Adjuster Slide	2
17	804026	Chute Adjuster Bracket, L/H	1
18	804016	Support, Windrower, L/H	1
19	804018	Support, Windrower, R/H	1
20	804020	Windrower Width Adjuster, L/H	1
21	804022	Windrower Width Adjuster, R/H	1
22	804025	Wing Bolt, Windrower	4
23	804028	Chute Adjuster Bracket, R/H	1
24	804194	5/16" Nut, Standard	2
25	800236	3/8" Nut, Standard	18
26	804196	1/2" Nut, Standard	2
27	807522	5/16" SAE Washer, Flat	10
28	807523	3/8" SAE Washer, Flat	42
29	807524	1/2" SAE Washer, Flat	4
30	807528	5/16" Washer, Lock	10
31	804366	3/8" Washer, Lock	24
32	804367	1/2" Washer, Lock	2

Spreader, Adjustable Attachment Kit K102

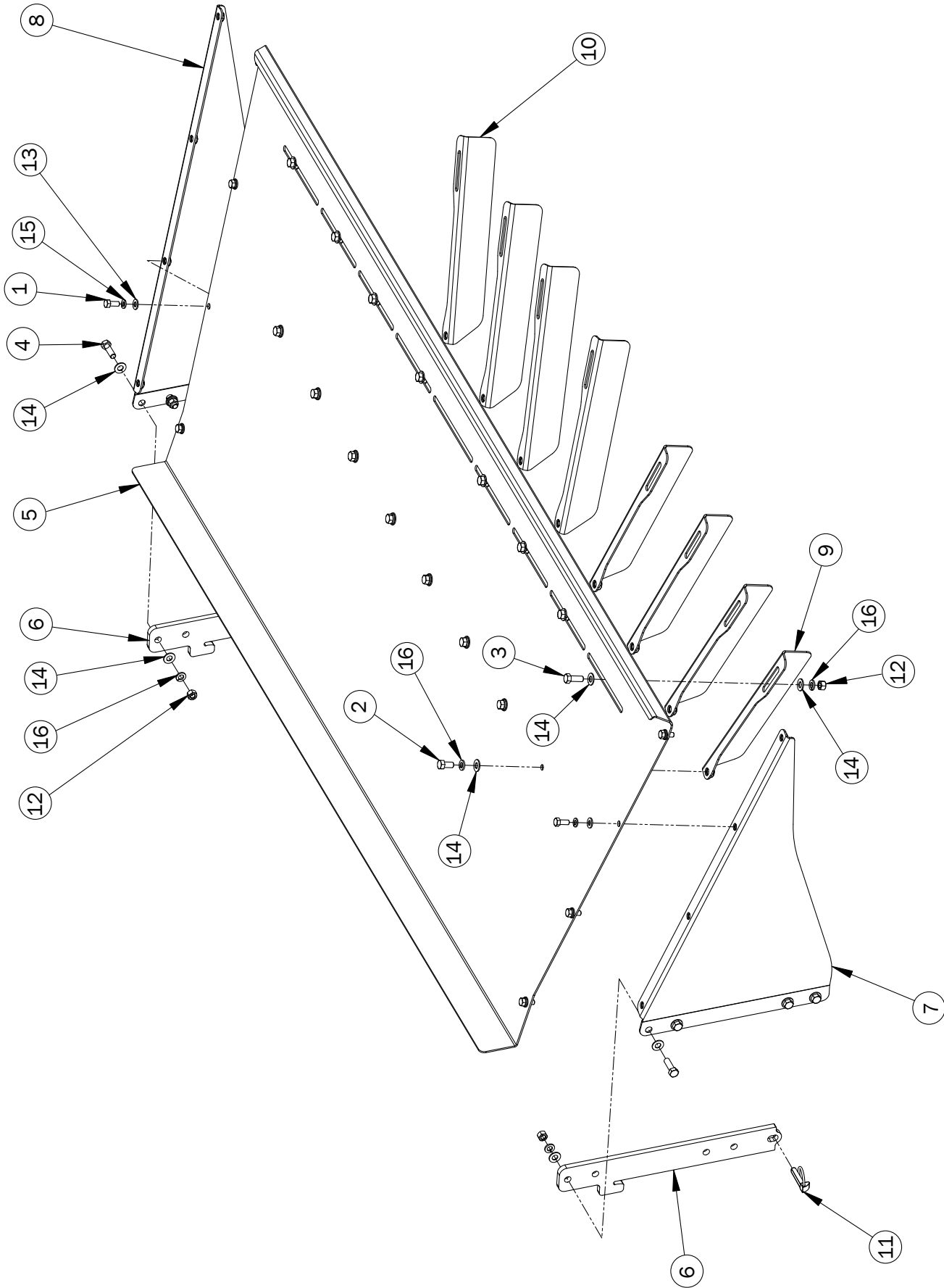

Spreader, Adjustable Attachment Kit K102

Item No.	Stock No.	Description	Qty.
1	800209	5/16" x 3/4" Bolt, Standard	8
2	803623	3/8" x 3/4" Bolt, Standard	8
3	800195	3/8" x 1" Bolt, Standard	8
4	800197	3/8" x 1-1/4" Bolt, Standard	8
5	807729	Spreader Top Plate	1
6	803996	Attachment Hook	2
7	804010	Spreader Support, L/H	1
8	804012	Spreader Support, R/H	1
9	807728	Fin - Spreader Adjustable, L/H	4
10	807726	Fin - Spreader Adjustable, R/H	4
11	801818	7/16" Lynch Pin	2
12	800236	3/8" Nut, Standard	16
13	807522	5/16" SAE Washer, Flat	8
14	807523	3/8" SAE Washer, Flat	40
15	807528	5/16" Washer, Lock	8
16	804366	3/8" Washer, Lock	24

Moldboard Attachment Kit K105

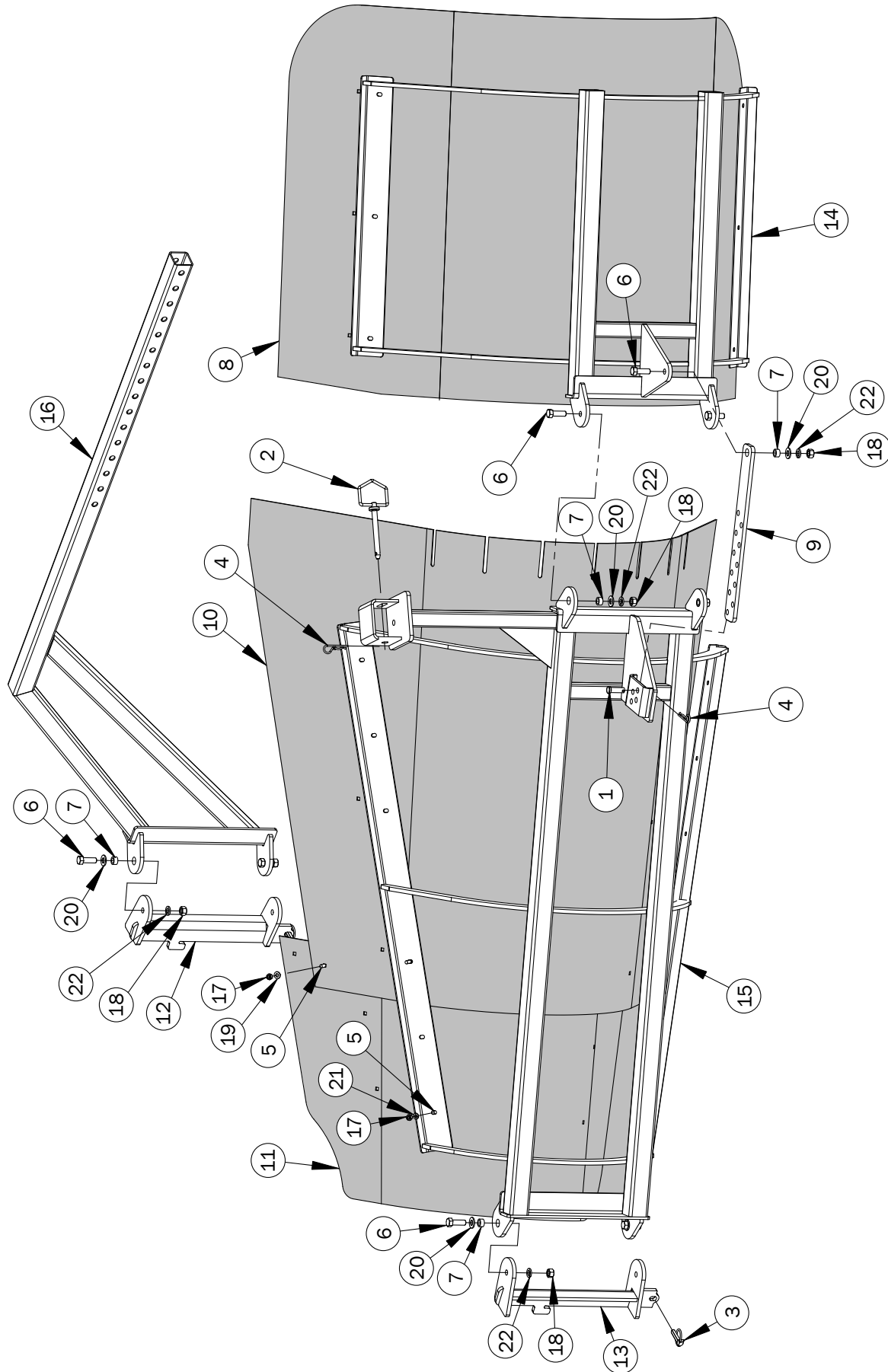

Moldboard Attachment Kit K105

Item No.	Stock No.	Description	Qty.
1	801081	Pin, Clevis, 1/2" x 1-3/4"	1
2	801082	Pin, 1/2" x 3-1/2"	1
3	801818	Pin, Lynch, 7/16"	2
4	801820	Pin, R, 1/8"	2
5	800062	5/16" x 3/4" Bolt, Carr.	18
6	800165	1/2" x 1-1/2" Bolt, Standard	7
7	803676	Moldboard Hinge Bushing	7
8	808547	Plastic Moldboard Extension	1
9	803692	Extension Angle Adjuster Bar	1
10	808546	Plastic Moldboard	1
11	808175	Plastic Moldboard	1
12	803696	Moldboard Quick Attach Hook, R/H	1
13	803694	Moldboard Quick Attach Hook, L/H	1
14	808566	Moldboard Extension Frame	1
15	810581	Main Frame, Moldboard	1
16	810584	Arm, Adjuster, Moldboard	1
17	804194	5/16" Nut, Standard	18
18	804196	1/2" Nut, Standard	7
19	807522	5/16" SAE Washer, Flat	2
20	807524	1/2" SAE Washer, Flat	7
21	807528	5/16" Washer, Lock	16
22	804367	1/2" Washer, Lock	7

Tedder Attachment Kit K104

Item No.	Stock No.	Description	Qty.
1	800321	Coupler, 1-3/8"	1
2	801682	Tedder, Daros (Rossi)	1
3	801818	Pin, Lynch, 7/16"	2
4	801820	Pin, R, 1/8"	1

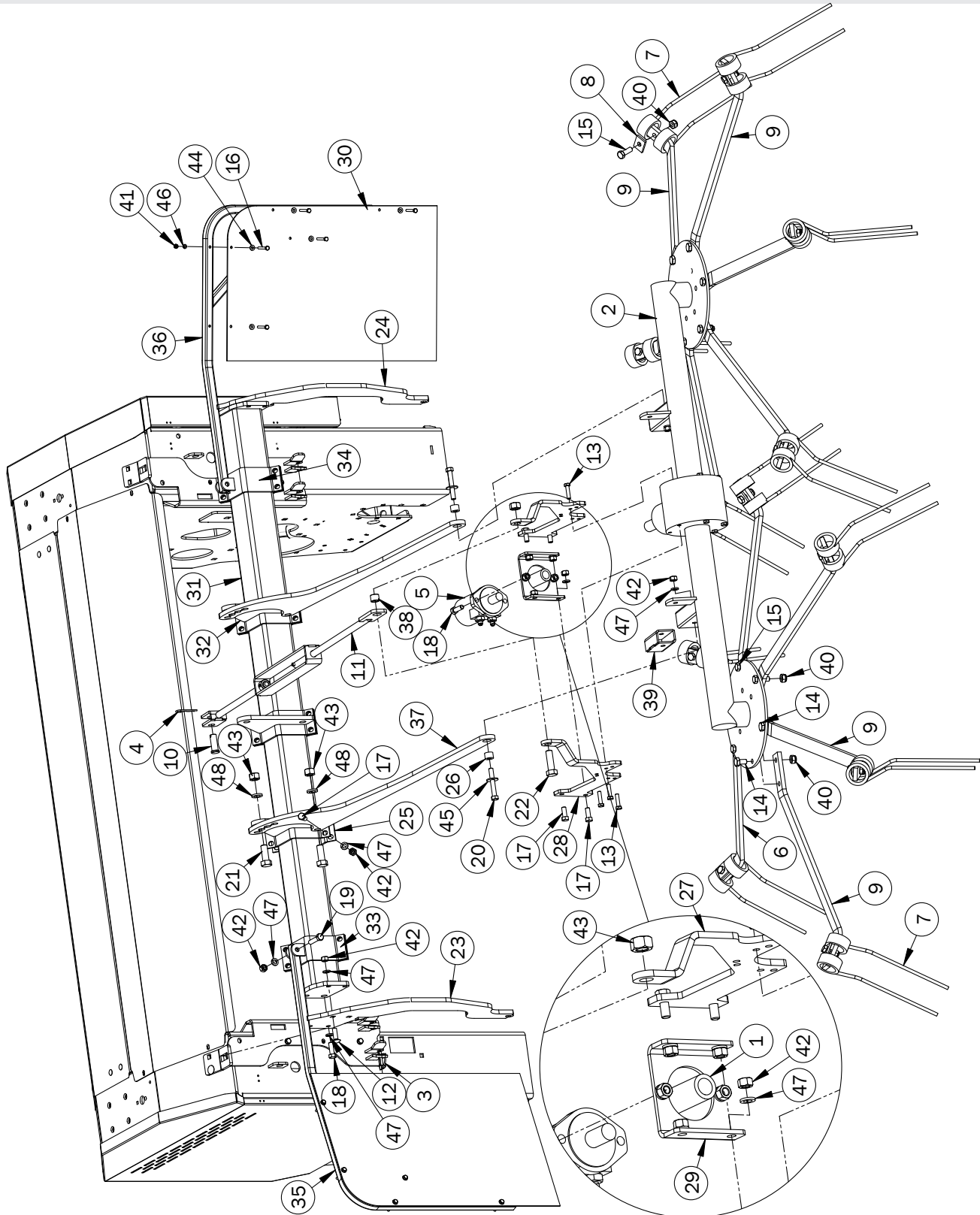

Tedder Attachment Kit K104

Item No.	Stock No.	Description	Qty.
5	808545	Motor, Hydraulic, 2006 DH 50 (See pages 76-77, Item 11)	-
6	809090	Tooth Arm, Fixed, Tedder	8
7	809091	Tooth, Tedder	12
8	809092	Plate, Tooth Clamp, Tedder	12
9	809096	Tooth Arm, Adjustable, Tedder	4
10	809586	Pin, Clevis, 3/4" x 2"	1
11	810158	Turnbuckle Assembly, Tedder (See pages 78-79)	1
12	800054	1/2" x 1-1/2" Bolt, Carr.	4
13	809040	10mm x 40mm Bolt, Metric	6
14	809098	14mm x 25mm Bolt, Metric	4
15	809094	14mm x 40mm Bolt, Metric	20
16	800182	1/4" x 2" Bolt, Standard	10
17	800166	1/2" x 1-1/4" Bolt, Standard	24
18	800165	1/2" x 1-1/2" Bolt, Standard	6
19	808784	1/2" x 2-1/4" Bolt, Standard, Gr. 8	2
20	800174	1/2" x 3-1/2" Bolt, Standard	2
21	800190	3/4" x 2" Bolt, Standard	4
22	800191	3/4" x 2-1/2" Bolt, Standard	1
23	810553	Tedder Attachment Hook, L/H	1
24	810555	Tedder Attachment Hook, R/H	1
25	808174	Tedder Clamp	5
26	808172	Tedder Attachment Arm Spacer	2
27	807861	Arm, Motor Mounting, R/H	1
28	807864	Arm, Motor Mounting, L/H	1
29	807859	Motor Mounting Plate	1
30	807882	Tedder Flap	2
31	807876	Tedder Main Beam	1
32	807844	Tedder Attachment Bracket	3
33	807854	Tedder Flap Attachment Bracket, L/H	1
34	807857	Tedder Flap Attachment Bracket, R/H	1
35	810559	Tedder Flap Frame, L/H	1
36	810562	Tedder Flap Frame, R/H	1
37	810557	Tedder Attachment Arm	2
38	810157	Bushing, Turnbuckle, Tedder	1
39	810566	Tube, Tedder Arm	2
40	809095	14mm Nut, Nylon Lock	24
41	800233	1/4" Nut, Standard	10
42	804196	1/2" Nut, Standard	34
43	804199	3/4" Nut, Standard	5
44	808781	1/4" SAE Washer, Flat	10
45	804364	1/2" Washer, Flat	2
46	808353	1/4" Washer, Lock	10
47	804367	1/2" Washer, Lock	38
48	804369	3/4" Washer, Lock	4

Tedder Attachment Kit K104 Hydraulics

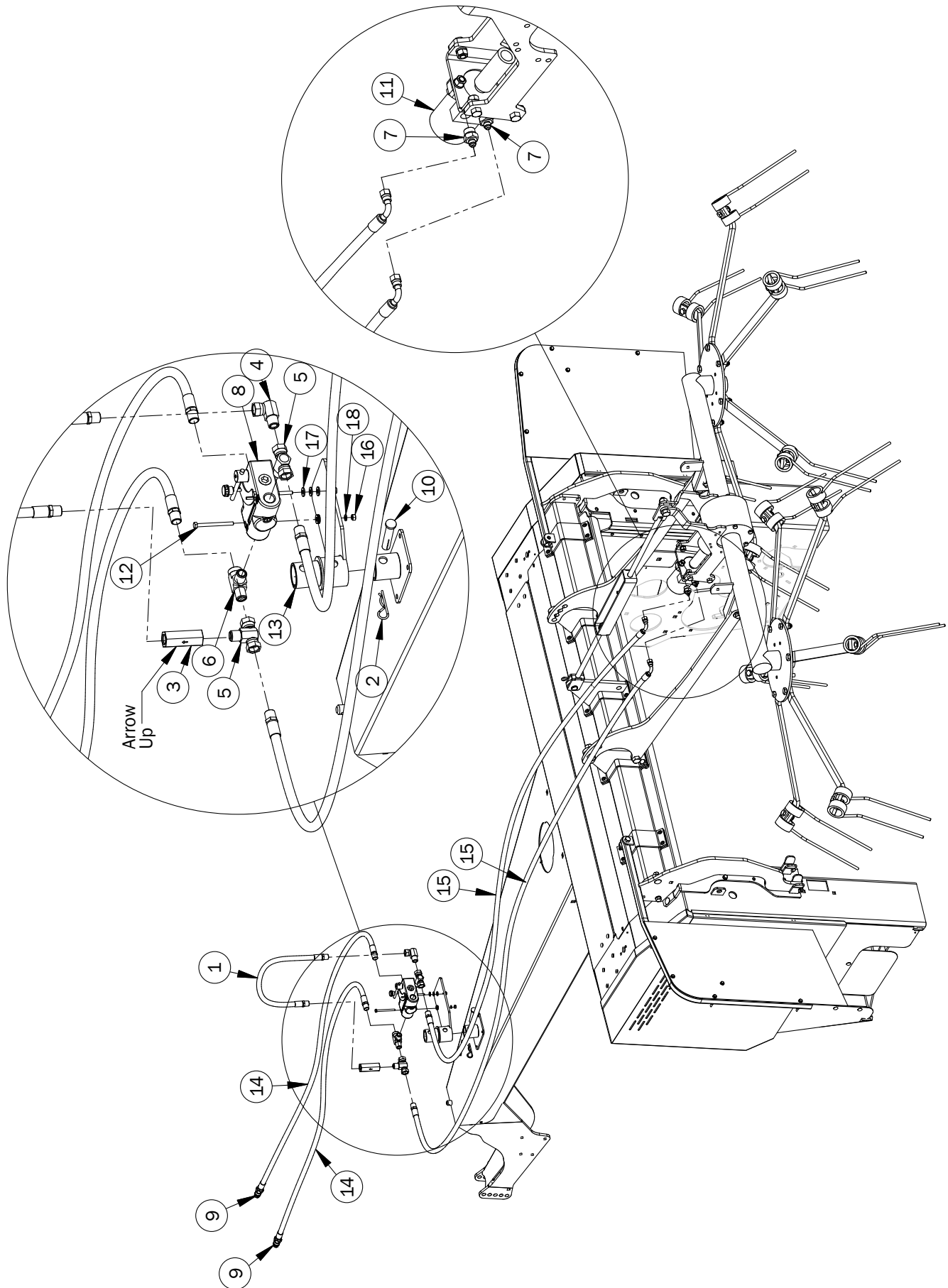

Tedder Attachment Kit K104 Hydraulics

Item No.	Stock No.	Description	Qty.
1	802478	Hydraulic Hose, 24"	1
2	801820	Pin, R, 1/8"	1
3	802474	Valve, Check	1
4	802482	Elbow, Hydraulic	1
5	802484	Tee, Hydraulic	2
6	802485	Tee, Hydraulic	1
7	802486	Adapter, Hydraulic	2
8	802836	Valve Body	1
9	804099	Quick Coupler	2
10	807055	Pin, Clevis	1
11	808545	Motor, Hydraulic, 2001 DH 50	1
12	808783	1/4" x 3" Bolt, Standard	2
13	807879	Valve Body Holder	1
14	808721	Hydraulic Hose	2
15	808722	Hydraulic Hose	2
16	800233	1/4" Nut, Standard	2
17	807522	5/16" SAE Washer, Flat	6
18	808353	1/4" Washer, Lock	2

Tedder Attachment Kit K104 Turnbuckle Assembly

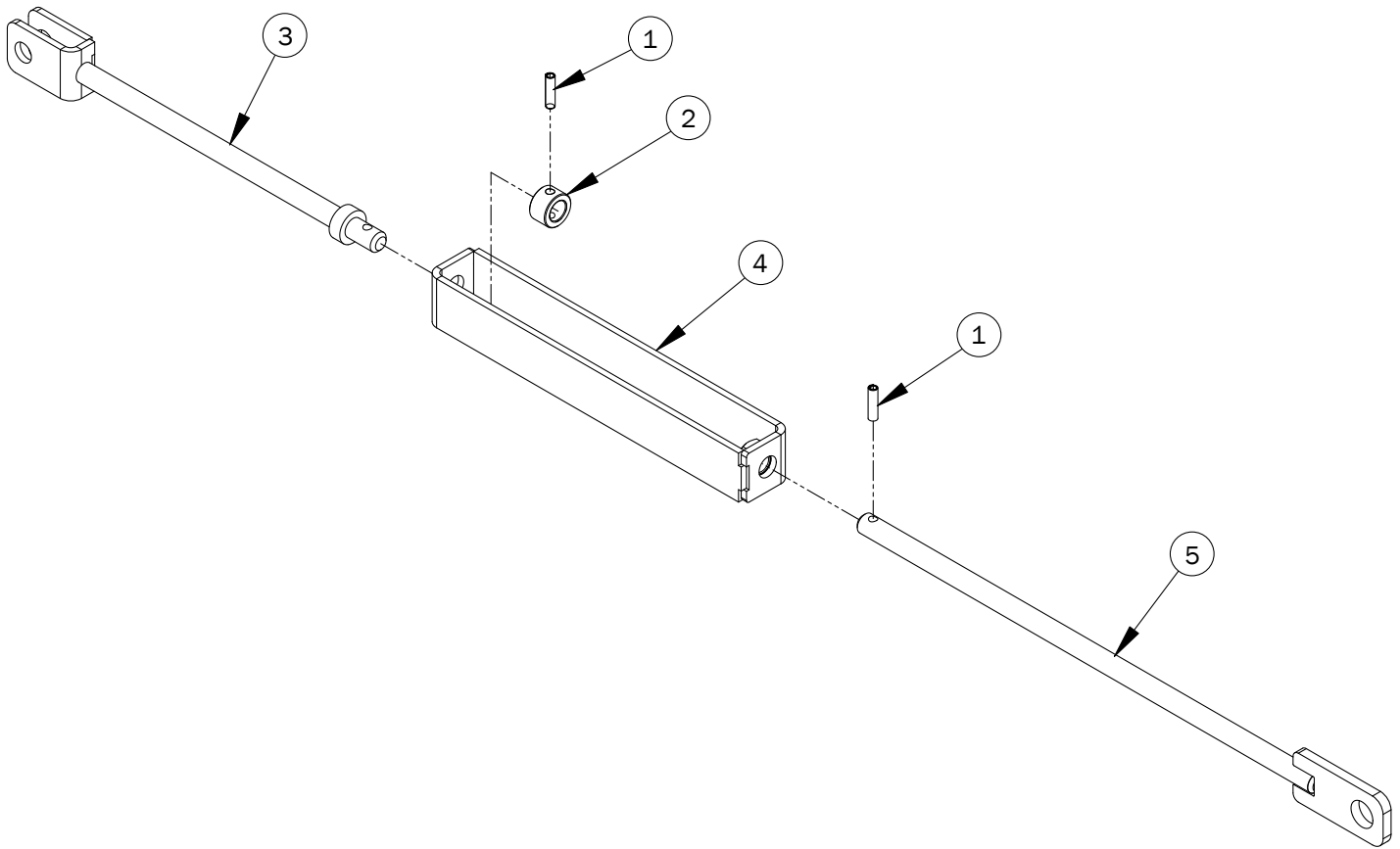

Tedder Attachment Kit K104 Turnbuckle Assembly

Item No.	Stock No.	Description	Qty.
1	809600	Pin, Coiled Spring, 0.312" x 1.25"	2
2	810155	Spacer, Bushing, Tedder	1
3	810138	Clevis, Turnbuckle, Tedder	1
4	810144	Arm Weldment, Turnbuckle, Tedder	1
5	810149	Rod Weldment, Turnbuckle, Tedder	1

Decals

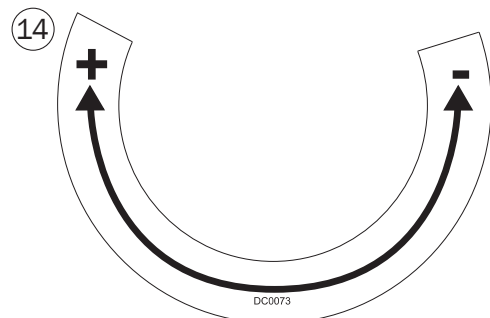
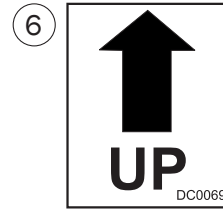
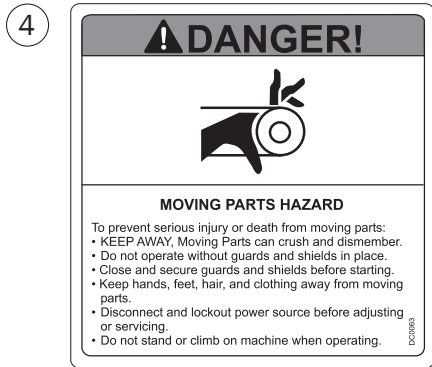
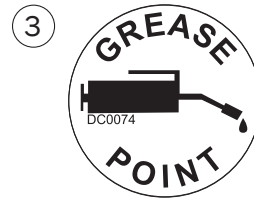

Decals

Item No.	Stock No.	Description	Qty.
1	808626	Macerator 6610 Side Panel Decal	2
2	808625	Side Panel Grains Decal	2
3	801621	Grease Point Decal	18
4	801620	Moving Parts Hazard Decal	3
5	801629	High Pressure Fluid Hazard Decal	4
6	801628	Up Decal	2
7	801615	AgLand Decal	2
8	801613	1000 RPM Decal	1
9	801625	Rubber Roll Air Bags Decal	1
10	801614	540 RPM Decal	1
11	801627	Steel Roll Air Bags Decal	1
12	801618	Air Tank Pressure Decal	1
13	801617	Air Tank Fill Decal	1
14	808660	Close/Widen Gap Decal	2
15	801619	Keep Shields and Guards in Place Decal	4

Index

Stock Number	Page Number	Stock Number	Page Number
		800212.....	13, 21, 37
800045	11, 13	800214.....	49
800048	21, 37, 38, 42, 45	800216.....	19
800054	37, 39, 43, 45, 59, 75	800219.....	3
800055	43, 67	800225	69
800057.....	3, 5, 37, 39	800228	11
800059	5, 19	800231.....	3
800061.....	43	800233	65, 75, 77
800062	3, 7, 9, 19, 59, 65, 73	800236	3, 5, 11, 13, 15, 19, 21, 39, 43, 51, 65, 69, 71
800064	19	800240.....	3, 19, 45, 55, 63
800065	37, 39, 43, 45	800259	11, 13, 21
800066	49	800276.....	17
800068	37, 43	800321.....	74
800072.....	55	800396	2
800073.....	19, 45, 55	800755	63
800133.....	37, 39, 43, 45, 53	800876.....	21
800143.....	63	800972.....	25, 27
800159.....	2, 17	801081.....	73
800164.....	19, 41	801082.....	73
800165.....	69, 73, 75	801169.....	41, 47
800166.....	19, 37, 39, 43, 45, 75	801171	15
800167.....	53	801176	41
800170.....	37, 43	801177	41, 47
800173.....	49	801481.....	39, 45
800174	37, 75	801484.....	37, 43
800176	55	801518.....	53
800182.....	75	801613.....	81
800187	37, 43	801614	81
800189.....	43	801615	81
800190.....	75	801617	81
800191.....	75	801618.....	81
800195.....	11, 13, 25, 27, 67, 69, 71	801619.....	81
800197	9, 11, 13, 19, 39, 45, 51, 69, 71	801620.....	81
800198.....	51	801621.....	81
800200	65	801625.....	81
800205	19, 59	801627	81
800206	19	801628.....	81
800207.....	13	801629.....	81
800209	3, 11, 13, 19, 65, 69, 71	801682.....	74
800210.....	43, 53	801714	63
800211.....	21	801732.....	65

Index

801818.....	3, 69, 71, 73, 74	803857.....	19
801820.....	38, 45, 49, 55, 73, 74, 77	803869.....	19
802474.....	77	803871.....	55
802478.....	77	803874.....	43
802482.....	77	803876.....	37
802484.....	77	803878.....	39, 45
802485.....	77	803884.....	37, 43, 53
802486.....	77	803892.....	43
802836.....	77	803894.....	43
802911.....	41	803895.....	39
802917.....	41	803897.....	21
802922.....	15	803902.....	37
803583.....	38	803904.....	39, 45
803585.....	42	803906.....	43
803586.....	13	803908.....	39, 45, 53
803587.....	42	803912.....	45
803611.....	3	803915.....	39
803612.....	3	803928.....	53
803622.....	19	803939.....	49
803623.....	13, 69, 71	803947.....	49
803625.....	3, 63	803950.....	51
803660.....	15	803951.....	49
803661.....	41	803953.....	51
803662.....	21, 25, 27, 41, 47	803955.....	51
803676.....	73	803959.....	55
803692.....	73	803962.....	49
803694.....	73	803994.....	9, 39, 45, 69
803696.....	73	803996.....	69, 71
803722.....	11	803998.....	69
803729.....	17	804000.....	69
803761.....	15	804002.....	69
803764.....	13	804010.....	71
803765.....	11	804012.....	71
803766.....	13	804016.....	69
803767.....	11	804018.....	69
803773.....	11	804020.....	69
803795.....	59	804022.....	69
803824.....	19	804025.....	69
803827.....	19	804026.....	69
803829.....	59	804028.....	69
803855.....	19	804032.....	65

Index

804037.....	39, 45	804149.....	63
804059.....	11	804150.....	63
804061.....	11, 13	804151.....	63
804062.....	11, 13	804152.....	63
804064.....	11, 13	804153.....	63
804066.....	11, 13	804154.....	63
804067.....	55	804155.....	37, 39, 42, 45
804069.....	57	804160.....	45
804070.....	57	804187.....	49
804071.....	57	804189.....	21, 31
804073.....	57	804190.....	11
804075.....	57	804191.....	3
804076.....	57	804194.....	3, 7, 9, 11, 13, 19, 59, 65, 69, 73
804077.....	57	804196.....	37, 39, 43, 45, 59, 67, 69, 73, 75
804078.....	55	804198.....	3, 13, 19, 37, 39, 43, 45
804080.....	57	804199.....	75
804081.....	21	804232.....	41
804082.....	21	804233.....	41
804087.....	21	804234.....	47
804090.....	19	804235.....	47
804099.....	59, 77	804236.....	41
804101.....	59	804237.....	13
804102.....	59	804238.....	15
804103.....	59	804239.....	15
804105.....	59	804301.....	19
804106.....	59, 65	804302.....	65
804107.....	63	804364.....	75
804108.....	63	804365.....	43
804109.....	63	804366.....	3, 5, 11, 13, 19, 39, 41, 43, 47, 51, 67, 69, 71
804110.....	19	804367.....	19, 37, 39, 41, 43, 45, 47, 49, 53, 59, 67, 69, 73, 75
804111.....	55	804368.....	3, 19, 21, 37, 39, 43, 45, 53, 55
804113.....	11	804369.....	43, 75
804116.....	41	806138.....	27
804134.....	15	806268.....	25, 27
804137.....	3	806269.....	25, 27
804142.....	25, 27, 63	806556.....	3, 19, 45, 55, 63
804143.....	63	806636.....	11, 39, 45
804144.....	63	806938.....	41
804146.....	63	806939.....	41
804147.....	63	806940.....	41
804148.....	63		

Index

806941	41	807546.....	3
806942	41	807550.....	19
806943	47	807558.....	21, 37, 39, 42, 45, 49, 55
807000.....	55	807559.....	3
807031.....	37	807562.....	21
807032.....	43	807563.....	21
807033.....	9	807564.....	21
807034.....	9	807565.....	21
807035.....	9	807578.....	19
807037.....	15	807581.....	3
807041.....	21	807591.....	37, 43
807043.....	9	807633.....	61
807045.....	5	807634.....	61
807047.....	5	807635.....	61
807052.....	37	807639.....	59
807055.....	49, 77	807642.....	59
807101.....	13	807685.....	9
807156.....	21	807705.....	59
807355.....	61	807706.....	39, 45
807356.....	61	807712.....	65
807402.....	13	807713.....	65
807403.....	19	807726.....	71
807406.....	11	807728.....	71
807445.....	59	807729.....	71
807449.....	59	807734.....	43
807451.....	59	807738.....	37
807452.....	59	807746.....	25, 27
807456.....	39	807747.....	25, 27
807457.....	39	807749.....	25, 27
807461.....	43	807750.....	25
807472.....	13	807757.....	55
807487.....	39	807778.....	37, 43
807513.....	21	807784.....	21, 31
807516.....	11, 13	807786.....	43
807517.....	37, 39, 43, 45	807788.....	37
807521.....	39	807791.....	21, 29
807522.....	3, 7, 9, 11, 13, 19, 69, 71, 73, 77	807792.....	21, 29
807523.....	3, 9, 11, 15, 19, 65, 69, 71	807794.....	41
807524.....	37, 39, 43, 45, 69, 73	807799.....	3
807525.....	21, 49	807802.....	65
807528.....	7, 11, 13, 19, 41, 59, 65, 69, 71, 73	807818.....	25

Index

807819.....	25, 27	807970.....	29, 31, 33, 35,
807820.....	25, 27	807971.....	31
807821.....	57	807972.....	29
807822.....	57	808015.....	31
807823.....	25	808016.....	29
807824.....	25	808017.....	31
807825.....	25, 27	808018.....	29
807826.....	27	808019.....	29
807828.....	67	808020.....	31
807830.....	67	808021.....	31
807835.....	25	808022.....	29
807836.....	25	808023.....	31
807837.....	25, 27	808024.....	29
807838.....	25	808025.....	29, 31
807839.....	25, 27	808026.....	29, 31
807841.....	25	808027.....	31
807843.....	27	808028.....	29
807844.....	75	808029.....	31
807847.....	25, 27	808030.....	29
807851.....	25, 27	808031.....	31
807852.....	25, 27	808032.....	29
807853.....	25, 27	808033.....	29
807854.....	75	808034.....	29
807857.....	75	808035.....	31
807859.....	75	808036.....	31
807861.....	75	808037.....	31
807864.....	75	808038.....	31
807866.....	21, 25, 27	808039.....	29
807869.....	11, 13	808040.....	29
807876.....	75	808041.....	29
807879.....	77	808042.....	31
807882.....	75	808043.....	29, 31
807884.....	39	808044.....	21, 31
807890.....	21, 37, 39, 43, 45	808045.....	21, 29
807919.....	65	808046.....	21, 29
807964.....	29	808047.....	21, 31
807965.....	31	808048.....	31
807966.....	29, 33, 35	808049.....	29
807967.....	31	808050.....	29
807968.....	31	808051.....	31
807969.....	29, 33, 35	808052.....	31

Index

808053	29	808357	23
808054	29	808358	23
808055	31	808359	23
808056	31	808360	23
808057	29	808362	37
808064	29, 31	808363	43
808065	35	808381	65
808066	35	808476	3
808067	33, 35	808522	37
808068	33	808530	37
808070	33	808545	75, 77
808072	33	808546	73
808073	33	808547	73
808074	33	808566	73
808075	33	808587	55
808076	33	808596	11
808077	33	808623	63
808078	33	808625	81
808107	21	808626	81
808109	21, 37, 39, 43, 45	808660	81
808111	15	808678	3
808115	55	808682	3
808123	23	808685	3
808128	23	808688	3
808172	75	808691	3
808174	75	808694	3
808175	73	808714	19
808200	21, 37, 39, 41, 43, 45	808716	3
808212	43	808718	3
808262	65	808719	3
808267	65	808720	3
808339	41, 47	808721	77
808340	41, 47	808722	77
808341	41	808776	21
808342	41	808781	75
808343	41	808783	77
808344	41	808784	75
808345	41	808816	3
808352	23	808965	43
808353	15, 41, 65, 75, 77	808966	37
808355	11, 13	809040	75

Index

809090	75	810504.....	7
809091.....	75	810509.....	7
809092	75	810512.....	7
809094	75	810523.....	43
809095	75	810524.....	37
809096	75	810531.....	49
809098	75	810536.....	49
809470.....	11	810550.....	37, 39, 43
809586	75	810553.....	75
809600	79	810555.....	75
810138.....	79	810557.....	75
810144	79	810559.....	75
810149	79	810562.....	75
810155.....	79	810566.....	75
810157	75	810581.....	73
810158.....	75	810584.....	73
810383.....	11, 13	810621.....	69
810386.....	13	810622.....	69
810388.....	19, 37, 39	810633.....	69
810392.....	19, 43, 45	810636.....	69
810398.....	55	810649.....	55
810406.....	55	810772	63
810407	55	810773	63
810408.....	55	810787	11
810410	53	801471r01	55
810412.....	53	801538r02.....	55
810416	53	801609r02.....	21
810418.....	53	801612r01.....	21
810420.....	55	803716r02	11
810422.....	55	803730r01.....	11
810427	19	803732r01.....	11
810429.....	19	803733r01.....	17
810432.....	59	803734r01.....	11
810435.....	59	803742r02	11
810437	19	803744r03	13
810446.....	19	803746r03	11
810473	19	803748r01	11
810494.....	63	803755r02.....	13
810496.....	37, 43	803760r01.....	13
810497	37, 43	803780r02.....	3
810501.....	7	803851r01.....	55

Index

803853r01.....	55
803861r01.....	3
803863r01.....	3
803865r01.....	55
803867r01.....	55
803927r01.....	45
803929r01.....	39
803938r01.....	49
803941r01.....	49
803946r01.....	55
803963r01.....	45
803966r02	49
803970r02.....	3
804035r01.....	39, 45
804039r01.....	39
804042r02	13, 39
804044r02	65
804049r01.....	39, 45
804050r02	39
804057r01.....	5
804114r02	21
804115r03.....	21
804157r01.....	3
807028r01.....	39

LIMITED WARRANTY

Warranty service will be performed by AgLand Dealer authorized to sell the Macerator.

AGLAND WARRANTY

AgLand Industries Inc. manufactures the AgLand Macerator. AgLand Industries Inc. (Manufacturer) warrants each Macerator sold by it to be free of defects in material or workmanship under normal use and service. The sole obligation of the Manufacturer is limited to repairing or replacing, as the Manufacturer may elect, any part or parts that prove, in the Manufacturer's judgement, to be defective in material or workmanship within one year* after delivery to the original Retail Purchaser under normal farm use. The defective part or parts will be replaced or repaired only to the original Retail Purchaser. Warranty repair or replacement will be done at the location of the AgLand dealer who sold the Macerator. Defective parts must be returned to the Manufacturer or Dealer who sold the Macerator at the expense of the Retail Purchaser to be inspected by the Manufacturer. Purchaser must give written notice to the Dealer from whom the Macerator was purchased of any claimed defect and the Dealer will repair or replace the part or parts found to be defective.

**3 months after delivery when purchased by a commercial operator.*

Note: The sole remedy of the Purchaser for claim under this warranty is the repair or replacement of defective parts.

This warranty does not extend to the drive components or tires, which are made by other manufacturers and carry warranties from said manufacturers. There are no representations, warranties, or conditions, express or implied, statutory or otherwise, except those herein contained and no agreement collateral otherwise except those herein contained, and no agreement collateral hereto shall be binding upon either party unless in writing hereon or attached hereto, signed by the Purchaser and accepted by the Manufacturer at its head office.

SERVICE AND WARRANTY INFORMATION

The Manufacturer's liability under this warranty is limited to the repairing or replacing of parts only, and the Manufacturer shall in no event be liable to the Retail Purchaser for consequential damage or loss of profits sustained by it as a result of any defect in material or workmanship on any of the equipment covered by this warranty.

The Macerator is warranted for agricultural use only. This warranty does not cover claims resulting from any use for other than agricultural applications.

Altering, modifying or adding additional equipment which is not approved for installation on the Macerator by the Manufacturer will void this warranty.

All warranties are subject to legislation of the state or province in which the Macerator is sold.

Note: There are no warranties, express or implied, by the Manufacturer or its Dealer regarding the Macerator except the warranty against defects in the material or workmanship expressed herein. No person is authorized to bind the Manufacturer to any other warranty whatsoever.

The Manufacturer reserves the right at any time to make changes in the design, material, parts, or specifications of the Macerator without thereby becoming liable to make similar changes in equipment, machinery or parts previously manufactured.



AgLand Industries Inc.