

ZENIT ZATURN JUPITER MERCURY



Original

Instruction book

67033402-100 - version 2.00

GB - 06.2020



www.hardi.es

www.hardi-international.com



Congratulations for choosing a HARDI crop protection product. The reliability and efficiency of this machine depend entirely on the care it receives. The first step is to carefully read and pay attention to this instruction book. It contains essential information on correctly using and ensuring a long useful life of this quality product.

As this instruction book includes all versions of the equipment, including the entire different hydraulic boom and operating unit versions, please pay particular attention to the paragraphs dealing with your specific model.

This book should be read in conjunction with the 'Spraying Techniques' booklet.

The original instruction book is approved and published in English. All other languages are translations of the original. In the event of any conflicts, inaccuracies or deviations between the English original and other languages the English version shall prevail.

Since it is ILEMO-HARDI S.A.U. policy to continually improve our products, we reserve the right to make changes in the design, accessories, specifications and maintenance instructions at any time and without notice.

ILEMO-HARDI S.A.U. is exempt from any obligation as regards instruments purchased before or after such changes. ILEMO-HARDI S.A.U. cannot undertake any responsibility for possible omissions or inaccuracies in this publication, although it has done everything in its power to make this information as complete and correct as possible.

As this instruction book covers models, specifications or equipment that are only available in certain countries, please pay particular attention to the paragraphs dealing with your specific model.

Published and printed by ILEMO-HARDI S.A.U.

Table of Contents

1 - EC Declaration	
EC Declaration of Conformity	7
2 - Safety	
Operator safety	9
Symbols.....	9
Precautions.....	9
3 - Description	
General information	11
Overview ZATURN, JUPITER	11
Overview MERCURY	13
Overview ZENIT	14
Use of the mistblower	15
Roadworthiness	16
Identification plate	16
Chassis.....	16
Tank.....	16
Liquid system	17
General information	17
The liquid circuit	17
Diaphragm pump.....	17
Valves	17
Valves and symbols.....	17
Manifold system.....	18
Blue valve – Blue disc = Return valve	18
Circuit Diagram ZATURN, JUPITER.....	19
Circuit Diagram ZENIT	20
Suction filter	20
Circuit diagram MERCURY	21
Safety valve.....	23
Safety Valve Activation	23
Pressure manifold.....	23
Suction and pressure pulsation dampers	23
Agitator.....	24
Operating unit.....	24
SA operating unit	24
CB operating unit	24
Filters	24
Powder mixer	24
TurboFiller	25
Axial blower units	26
Technical information.....	26
EF820, EF920, AB750, AB820, AB920, AG820, AG920, IAG820, IAG920, SF65, SF85 and XF90.....	26
Air flow for axial air kits	28
Deflectors.....	29
Gearbox.....	30
Fan	30
Specific for SF and XF axial fans	30
Centrifugal Blower Units (Turbines)	31
General information	31
HF540 (TS3 P540 / TS6 P540 Single).....	31
HF540D (TD3-P540 Double)	31
HF640D (TD3-P640 Double)	31
Protective grid.....	32
Gearbox.....	33
HF540, HF540D and HF 640D Turbines	33
Clutch (All blower types)	33
Equipment	34
Ring drawbar.....	34
Fork drawbar	34

Table of Contents

Turnable drawbar	34
Wedges.....	35
Light kit.....	35
Booms.....	35
The LINER boom	35
The ATLAS boom	36
The BOXER boom	36
The CRONOS boom.....	37
Break away clutch	38
Particularly for CRONOS boom	38
The RAIL boom	39
OPTIMUS 15	40
OPTIMUS 35	41
OPTIMUS 55	41

4 - Starting up

General information.....	42
Unloading the mistblower from the truck	42
Before starting up for the first time.....	42
Counterweights	42
Mechanical connections	43
Adjusting the drawbar length.....	43
Jockey wheel.....	43
Connecting the fork drawbar	43
Connecting the ring drawbar.....	43
Connecting the turnable drawbar	44
Lock device on turnable drawbar	44
Hooking up the mistblower	45
Towing	45
Disablement.....	46
Coupling the driveshaft.....	48
Hydraulic connections.....	49
General information	49
Tractor requirements.....	49
Electrical connections	50
General information	50
Standard control box	50
Technical control box.....	50
Rate controller.....	51
Rate controller DB 3610.....	52
Rate controller DB 3620.....	52
Fluid circuit	53
Suction filter	53
Pressure damper.....	53
Diaphragm pump.....	53
Piston pumps.....	53
Deflectors.....	54
Booms	57
General information	57
FIX	57
START	57
ATLAS AGILE.....	58
ATLAS SOLID and ATLAS SOLID GV.....	58
ATLAS SOLID and ATLAS SOLID GV	58
BOXER SOLID VERTICAL.....	58
BOXER SOLID HORIZONTAL	58
Adjustment of BOXER boom.....	59
CRONOS BOOM.....	59
RIDER.....	59
VARIA.....	60
CRONOS GV	60

Table of Contents

General for all boom models	61
Break away clutch	61
Adjustment of hydraulic fold	61
Transport bracket	62
Adjustment of upright	62
Adjustment of out spray device.....	62
The hydraulic version.....	63
Adjustment of inner 4 spray device.....	63
Hydraulic adjustment of the Convert brackets	63
OPTIMUS spray spouts.....	64
Cannons	65
Calibration.....	65

5 - Operation

Blower unit..... 67

Safety information	67
Selecting the gear.....	67
While moving the Sprayer	68
Adjusting the fan A6820 and SF65/SF85 and XF90	69
Single side blinds (Optional)	69

Fluid circuit 70

Filling/washing location requirements.....	70
Filling with water	70
Filling through tank lid.....	71
Filling the rinsing tank.....	71
Rinsing nozzle.....	71
Filling the clean water tank.....	72
Drain valve	72
Manifold system.....	72
Manifold valves and pressure distributor MERCURY	73
Suction Filter.....	75
Filling liquid chemicals with HARDI TurboFiller (optional)	75
TurboFiller rinsing.....	76
Pressure filters.....	77
Agitation	77
Clean water tank.....	77
Powder mixer.....	77
Filling through tank lid.....	78
Filling the rinsing tank.....	78
Power supply.....	79
Installation of control unit brackets.....	79
SV operating unit.....	80
The CA Operating unit: 2, 4 or more sections	80
CB operating unit.....	80
CB operating unit with bypass valve.....	81
Control boxes.....	81
FB 3610	81
FB 3620	81
HB 3610	81
The Joystick S selector	82
HB 3620	82
Cannon L-M-T	82
Hydraulic control of the CANNON	83
The hydraulic adjustment	83
Throttle valves	83
Vegetation sensor is optionally equipped.....	84
Rate controller DB3610	85
Rate controller DB3620	86
Extended joystick	87
Example of speed and pressure limit settings.....	87

Table of Contents

Cleaning	88
General information	88
Cleaning and maintaining the filters	88
Cleaning the tank and liquid system	89
Use of rinsing tank and rinsing nozzles (optional).....	89
6 - Maintenance	
Lubrication	92
General information	92
Lubricating and greasing the mistblower	92
Suitable lubricants	93
Transmission shaft	95
Tank transmission shaft	95
Diaphragm pump.....	95
Piston pump	96
Filters and fittings.....	96
Fork drawbar	96
Ring drawbar.....	96
Turnable drawbar.....	97
Axles with brake.....	97
Service and maintenance intervals	98
General information	98
Every 10 working hours – Spray circuit	98
Every 10 working hours – Suction filter	98
Every 10 working hours – Pressure filters.....	99
Every 10 working hours – Nozzles.....	99
Every 50 working hours – Transmission shaft, chassis, air pressure and diaphragm pump	100
Every 100 working hours – Drawbar.....	100
Every 250 working hours – Wheels, brakes, hoses and gearbox	100
Every 1000 working hours – Full service.....	100
Every 1000 working hours - Gearbox oil change	100
Every 1000 working hours - Fan clutch inspection.....	101
Annual maintenance of tank PTO	102
Occasional maintenance	103
Replacing the 321 valves and diaphragms	103
SV operating unit.....	103
CB Section valve.....	104
Cleaning the air kit	106
Tank level indicator adjustment.....	107
Replacing the valves and 364 and 464 diaphragms	107
Grease Gun Calibration.....	108
Greasing the Pump	108
Service and Maintenance Intervals	109
50 Hours Service - Greasing the Pump.....	109
Occasional Maintenance	110
Lifting and Removing the Pump.....	110
Pump Valves and Diaphragms Renewal	110
Piston pumps	112
Adjusting the 3-way valve	114
Replacing the driveshaft protector guard	114
Replacing the driveshaft crossheads	114
Replacing the seal on the drain valve.....	115
Storing the mistblower at the end of the season	115
Preparing the machine for use after storage	116
7 - Troubleshooting	
Operational problems	117
General information	117
Fluid circuit.....	118
Blower unit	119
Electrical problems	120
Emergency function – Fluid circuit.....	120

8 - Technical specifications

Axial dimensions and weight	121
Dimensions	123
Zenit Axial	123
Zenit Liner	123
Turbines dimensions and weight	124
Conversion factors (SI to Imperial).....	126
Specifications	127
Pump model 363/7	127
Pump model 321/10	127
Filters and nozzles.....	127
Temperature and pressure range.....	127
Materials and recycling.....	128
Disposing of the mistblower.....	128

Index

Table of Contents

EC Declaration of Conformity



Manufacturer: ILEMO HARDI S.A.U.
Polígono Industrial El Segre, 712, 713
25191 Lleida
SPAIN

Hereby declare that the following product

Field sprayer
ZENIT - ZATURN - JUPITER - MERCURY
Identification number*
Specific for each sprayer

* Further data for this sprayer are shown on its type sign.

fulfils all the relevant provisions of the following Directives of the European Parliament and of the Council:

- 2006/42/EC, regarding the Machinery Directive (CE marking).
- 2009/127/EC, and later amendments, regarding machinery for pesticide application.
- 2014/30/EU, regarding electromagnetic compatibility (EMC). Electronic components on the machine are tested and installed according to the requirements of the EMC Directive.

as well as the following ISO standard.

- ISO 14982, regarding test methods and acceptance criteria for electromagnetic compatibility for agricultural machinery.

ILEMO HARDI S.A.U.
Lleida, SPAIN

Date	September 2019
Signature	
Name	Mr. Josep Antoni Minguell
Job title	Managing Director, ILEMO HARDI S.A.U.

Operator safety

Symbols

These symbols are used in the book and require special attention. The meaning of the four symbols is:



This symbol means DANGER. Be alert as your safety is involved!



This symbol means WARNING. Be alert as your safety may be involved!



This symbol means ATTENTION. This will guide you on how to correctly and safely use the sprayer equipment.



This symbol means NOTE.

Precautions

Please note these precautions and safe operating practices before using the sprayer.

General information



Read and fully understand this instruction book before using the equipment. It is also equally important that other operators of the equipment read and understand this book.

If you do not fully understand any part of this instruction book after reading it, please contact your HARDI distributor for further information before using the equipment.



Local law may demand the operator to be certified to use this spray equipment. Comply with the law.



The tractor seat is the safest area when handling the equipment.



Wear protective clothing. Protective clothing may vary according to the chemical product being used. Comply with regulations. Wash and change clothes after spraying. Clean the tools if they are contaminated.



Do not eat, drink or smoke while spraying or working with contaminated equipment.

In the event of poisoning, immediately seek medical advice. Remember to identify the chemicals used.



If any of the warning stickers deteriorate, or break, it must be replaced immediately. Through the AGROPARTS service it can be obtained a new one.

Filling and spraying



Be careful not to hit people or objects while manoeuvring the spraying equipment, especially when reversing.



Slow down when driving over uneven terrain as the machine could overturn.



Keep children away from the sprayer.



Do not attempt to enter the tank.



Do not climb over the sprayer unless it has been securely fastened. The boom is only secure when it is placed on the transport brackets.

2 - Safety

Service



Always pressure test with clean water before filling with chemicals. Do not remove the hose if the machine is turned on.

DANGER! Do not exceed the maximum recommended r.p.m.



Rinse and wash out the equipment after use and before servicing.



Do not remove the hose if the machine is turned on. Always replace all safety devices or shields immediately after servicing.



Disconnect the power supply before servicing, and de-pressurise the equipment after use and servicing.



If an arc welder is used on the equipment, disconnect any power leads before welding.



Remove all inflammable or explosive materials from the area.



The External Cleaning Device should not be used if any part of the equipment has been damaged, including safety devices, high-pressure hoses, etc.



Be careful when work during a storm, there is a risk of lightning striking the equipment.



The equipment must not circulate on land that exceeds a 36% inclination.

General information

Overview ZATURN, JUPITER

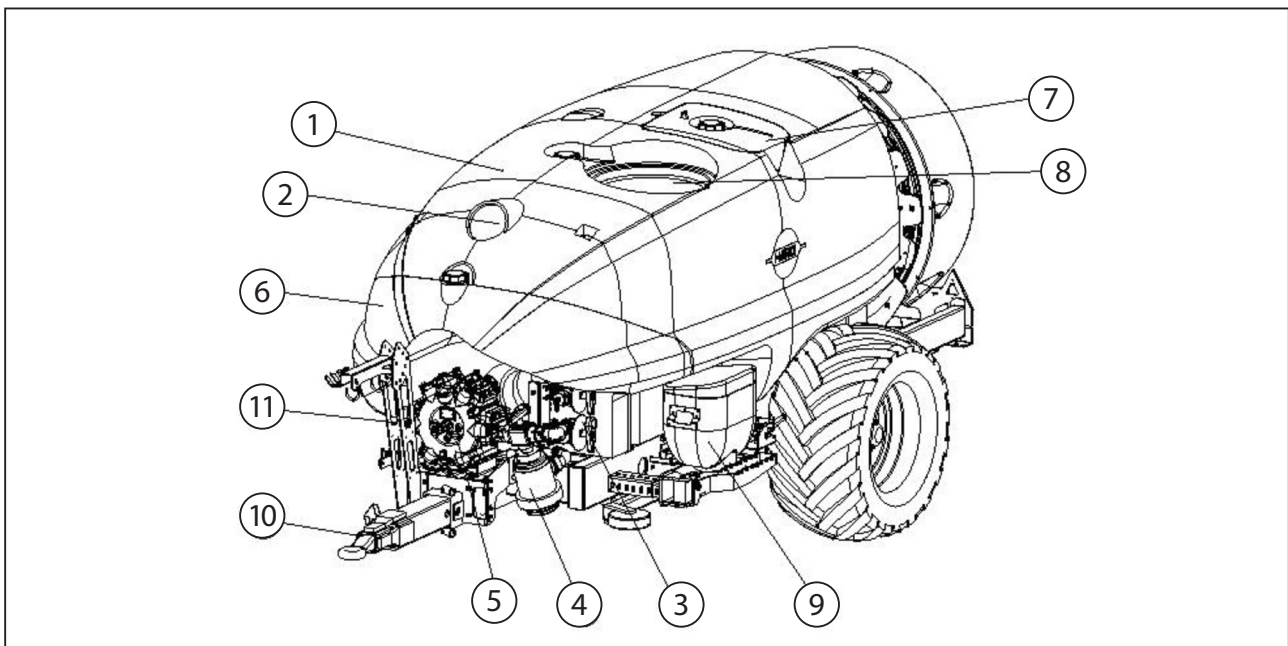

- | | |
|---------------------------------------------------|--------------------------|
| 1. Main tank | 7. Clean water tank |
| 2. Level indicator, optionally on top of the tank | 8. Main lid and strainer |
| 3. Manifold valves | 9. TurboFiller |
| 4. Suction filter | 10. Drawbar |
| 5. Pump | 11. Operating unit |
| 6. Rinsing tank | |

3 - Description

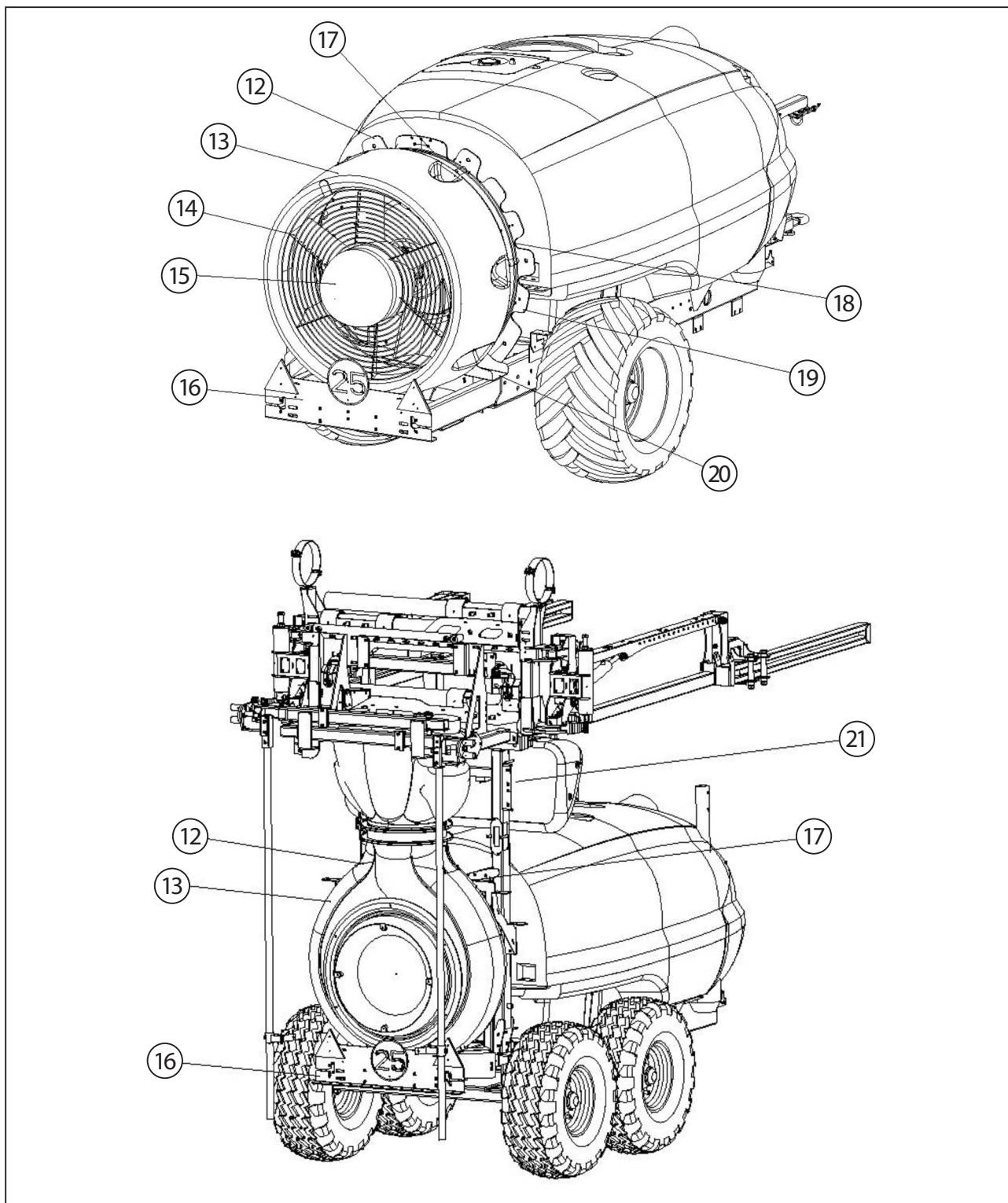

- 12. Chassis
- 13. Fan house
- 14. Grid and air guide
- 15. Centre cover
- 16. Bumper and light bar

- 17. Gear box filling point
- 18. Air outlet
- 19. Spray line
- 20. Adjustable bottom deflector
- 21. Operating unit and hydraulic valves

General information

Overview MERCURY

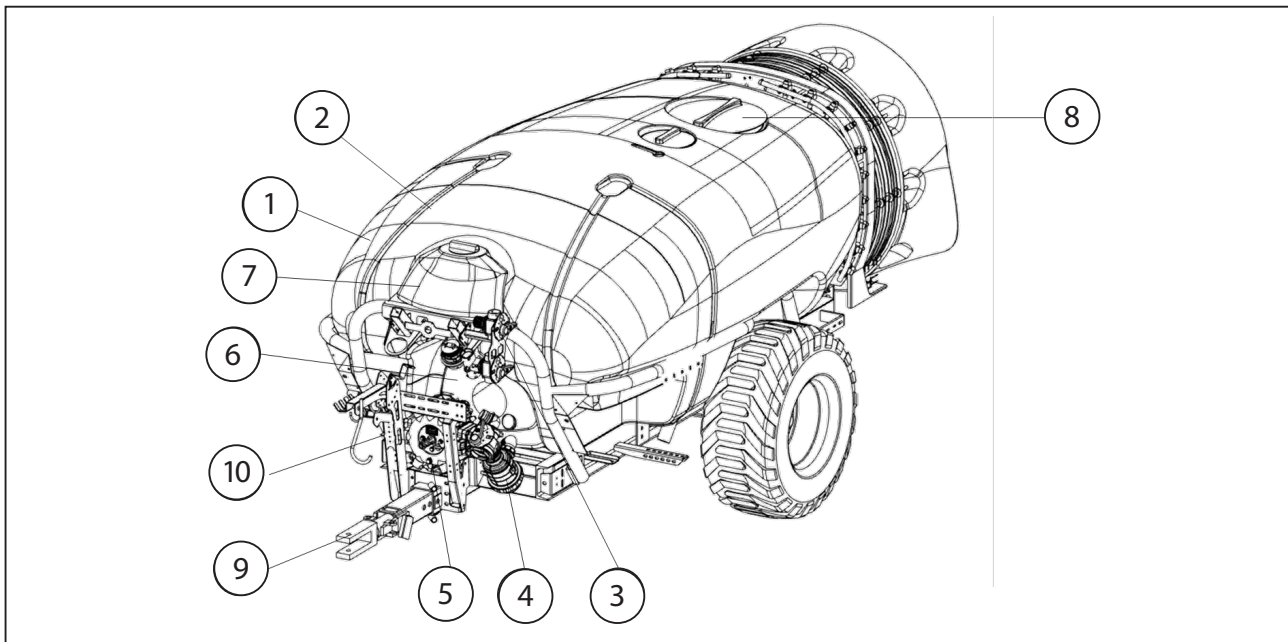

- | | |
|---------------------------------------------------|--------------------------|
| 1. Main tank | 7. Clean water tank |
| 2. Level indicator, optionally on top of the tank | 8. Main lid and strainer |
| 3. Manifold valves | 9. Drawbar |
| 4. Suction filter | 10. Operating unit |
| 5. Pump | |
| 6. Rinsing tank | |

3 - Description

Overview ZENIT

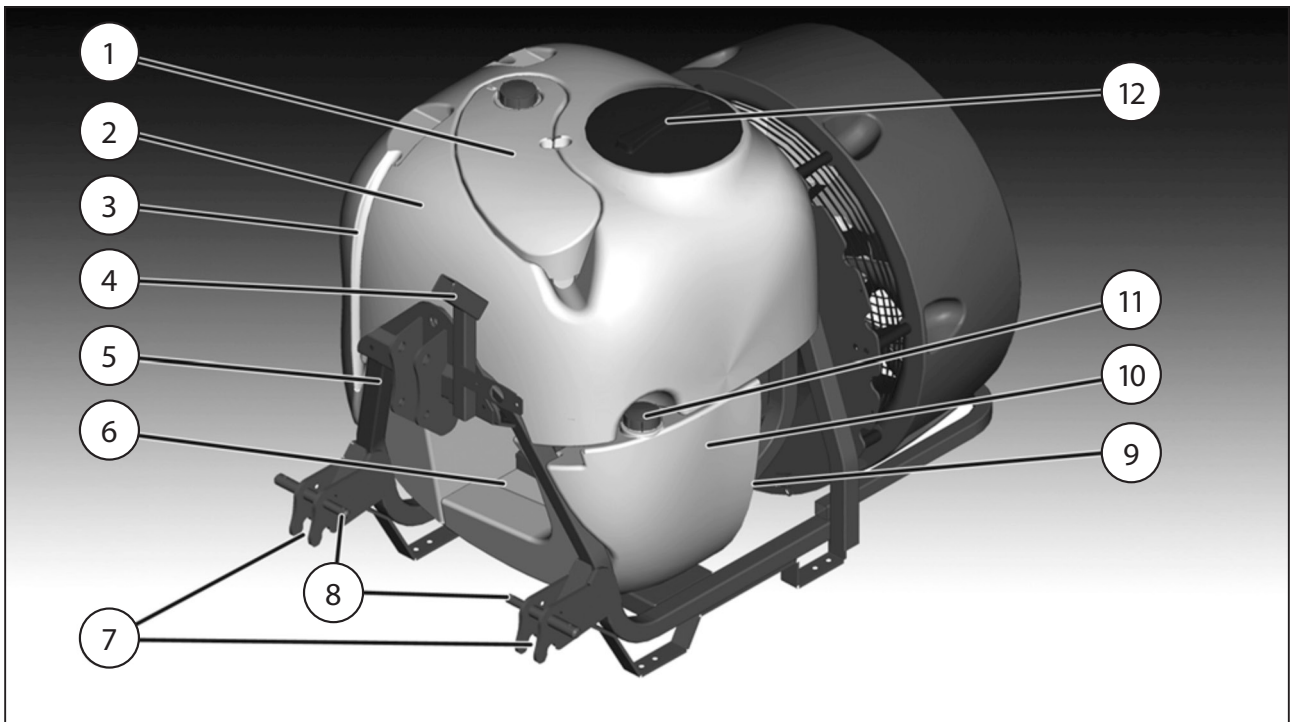

- | | |
|--------------------------|--------------------------|
| 1. Clean water tank | 7. Quick hitch |
| 2. Main tank | 8. Attachment, lift arms |
| 3. Front level indicator | 9. Suction filter |
| 4. Operating Unit | 10. Rinse tank |
| 5. 3-point hitch | 11. Rinse tank cap |
| 6. Pump | 12. Main tank lid |

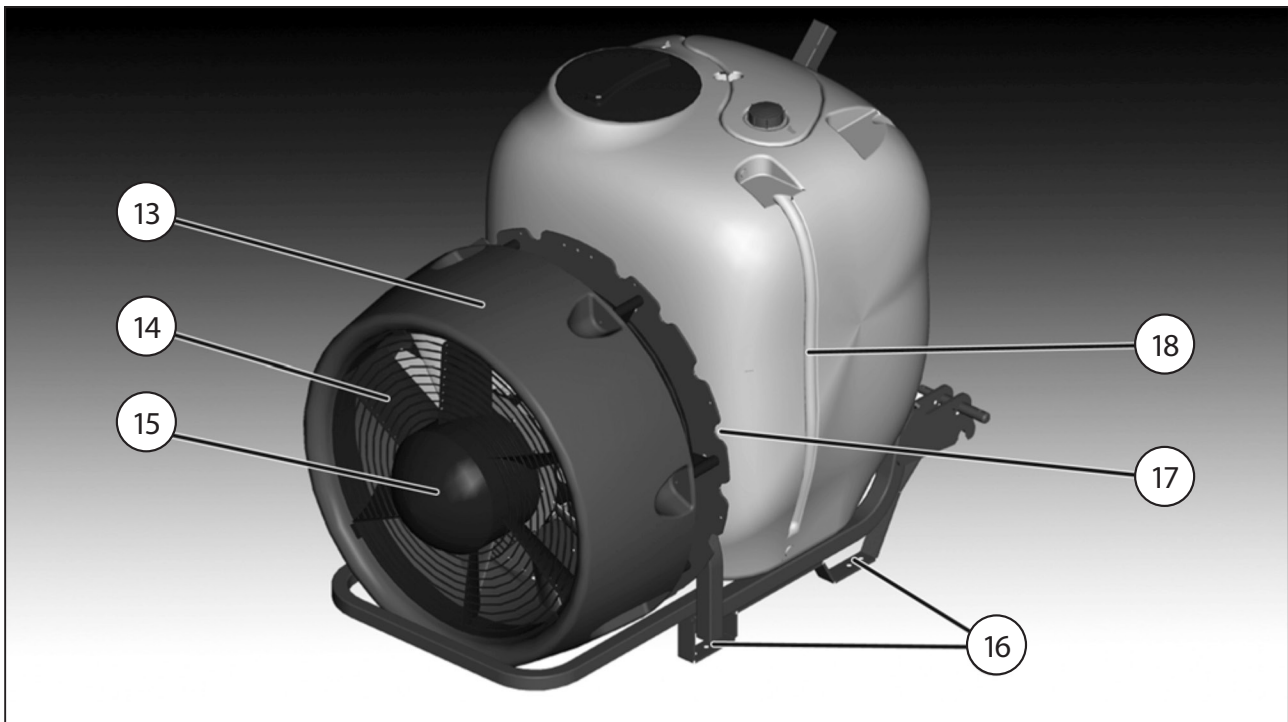

- 13. Polyethylene fan housing
- 14. Air inlet grid
- 15. Fan
- 16. Support legs
- 17. Air outlet grid
- 18. Side level indicator

The illustrations are covering axial and turbine machines, both can be equipped with optional extras, that might be or not be illustrated. The turbine machine is either equipped with boom or a cannon spout, as well as the axial machines might be equipped with deflectors. More details are described further ahead in this chapter, and the following.

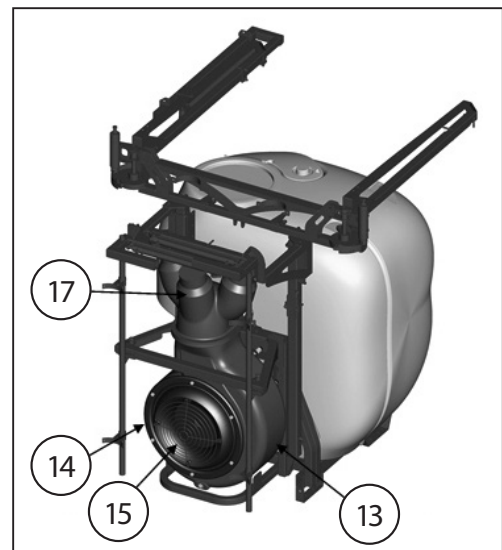

Use of the mistblower

Any addition and / or modification made to the equipment, outside of the ILEMO-HARDI manufacturing criteria, may alter the integrity and / or stability. These will be borne by the person responsible for making such modifications.

The HARDI mistblower is designed for applying chemical products used for crop protection. This equipment may only be used for this purpose. The use of this equipment for other purposes is not allowed. If there is no special law in your region which obliges the user to have a permit, it is recommended to be well-prepared for protecting crops in a correct way and for handling chemical products safely so as to avoid unnecessary risks to people and the environment while spraying takes place.

For environmental issues the air kit is offered with option to close either left or right side of the air stream from the blower. These blinds, are mandatory in some sensitive areas, to avoid chemical contaminated air, blowing towards river sides and water channels

3 - Description

Roadworthiness

When driving on public roads and other places where the road safety code or where there are other special rules and regulations for marking and lights on machinery, the machine must be equipped to comply with these regulations.



ATTENTION! For models not fitted with brakes the maximum speed is 25 km/h and 40 km/h for those with brakes.

This could vary according to local legislation. Contact your local authorities to find out the current maximum speed limits.

Identification plate

The identification plate is located on the front right-hand side of the machine and is riveted to the chassis. It indicates the make, model, serial number, and date of manufacture.

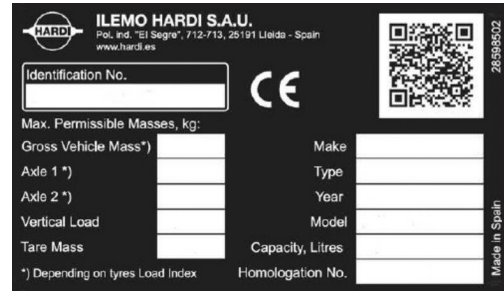

The serial number is also engraved onto the chassis. The number is found above the identification plate, as indicated in the picture. The serial number consists of a combination of numbers and letters that indicate the model, the year of manufacturing among others.



Identification number

MODEL	INICIAL NUMBERS SERIAL NUMBER	
	AXIAL	VINEYARD
ZP/NP/JP 2000	UKHAX204*****	UKHVV204*****
MR 2000	UKHAX206*****	UKHVV206*****
ZP 3000	UKHAX205*****	UKHVV205*****
ZP/JP 1500	UKHAX203*****	UKHVV203*****
ZC 600/800/1000/1300	UKHAX202*****	UKHVV202*****
ZP 1000		

Chassis

The monoblock cold-pressed metal chassis is highly durable and built to last under everyday use under extreme conditions. It is manufactured using only the most advanced laser cutting and automated welding processes. To protect against corrosion it is coated with a polyurethane bi-component paint on top of a highly adherent, steel blasted base.

Tank

The main tank made of impact-proof, UV-resistant and chemical resistant polyethylene has a purposeful design with no sharp corners for easy cleaning. Nominal contents are 1000, 1500, 2000 or 3000 l. A large, easy to read tank contents indicator is placed on the front - right-hand side and another one is placed on the left side. First one is visible from the tractor cabin. The filling hole is accessible from the left-hand side. This ensures an easy access for the filling of spray liquid, cleaning of the tank, etc. The mistblower is equipped with a clean water tank integrated with the main tank design.

Liquid system

General information

All the suction system functions are operated via a 3-way valve. The pressure valve is also to be found in the pressure circuit. The low pressure circuit is called HLC (Hardi Liquid Circuit).

The liquid circuit

Consist of manifold system in the working zone (front part) where pressure manifold receives liquid from the pump, and distributes to the different options on the sprayer – to the operating unit, to the TurboFiller, to the bottle cleaner, to the Powder mixer in strainer etc., all according to configuration of options. The suction manifold in same area allows suction from main tank, rinsing tank or external water source, if fitted, depending on its configuration.

The pressure side of the liquid circuit is fitted with a safety valve to protect the circuit against misuse of excessive pressure. See chapter "Safety valve"

Diaphragm pump

Pumps with a diaphragm: Models 321/10 (max. 20 bar) or 363/7 (max. 20 bar)

They are low pressure and robustly built. Use only grease for lubrication. The 363 model has six diaphragms and the 321 has two. This type of pump is self-priming, works without oil and can run dry as long as necessary.

Valves

The suction valve is located above the pump and is used to select where to suck liquid from. Either suction from the main tank for spraying or from the rinse tank for internal cleaning of the liquid circuit. The function is selected by turning the handle of the valve towards the desired function.

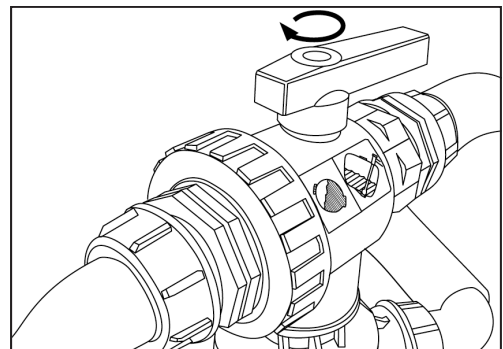

ATTENTION! If one of the handles is too tight - or too loose (=liquid loss) - the valve needs to be serviced. For more information, see section on "Maintenance".

Valves and symbols

The valves are identified by coloured discs fitted on the valves themselves. The symbols correspond to the optional accessories, and are located on the discs for quick identification and handling. To activate/open a function, turn the lever to the desired function.



ATTENTION: Only the functions to be used should be activated – the other valves should always be kept closed.

3 - Description

Manifold system

The functions of the spray circuit are operated via the centrally situated MANIFOLD with colour coded plates and pictorial symbols for easy operation.

The modular valve system facilitates the addition of optional extras on both pressure (A) and suction (B) for agitation and for rinsing nozzle (optional equipment).

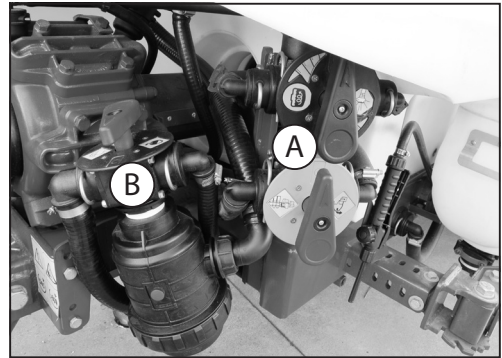

Blue valve – Blue disc = Return valve

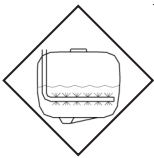

Towards agitation

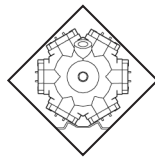

Towards the suction pump

The position of the return MANIFOLD valve determines where the excess flow from the fluid circuit goes. When the arrow on the handle points to a symbol, the excess fluid will be fully sent towards that function (the example shows agitation). This valve does not have the '0' position.

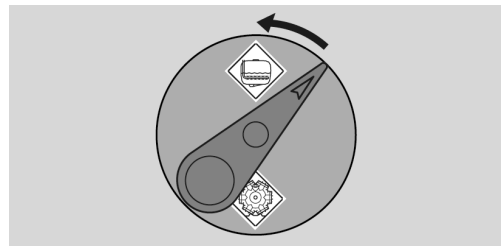

Circuit Diagram ZATURN, JUPITER

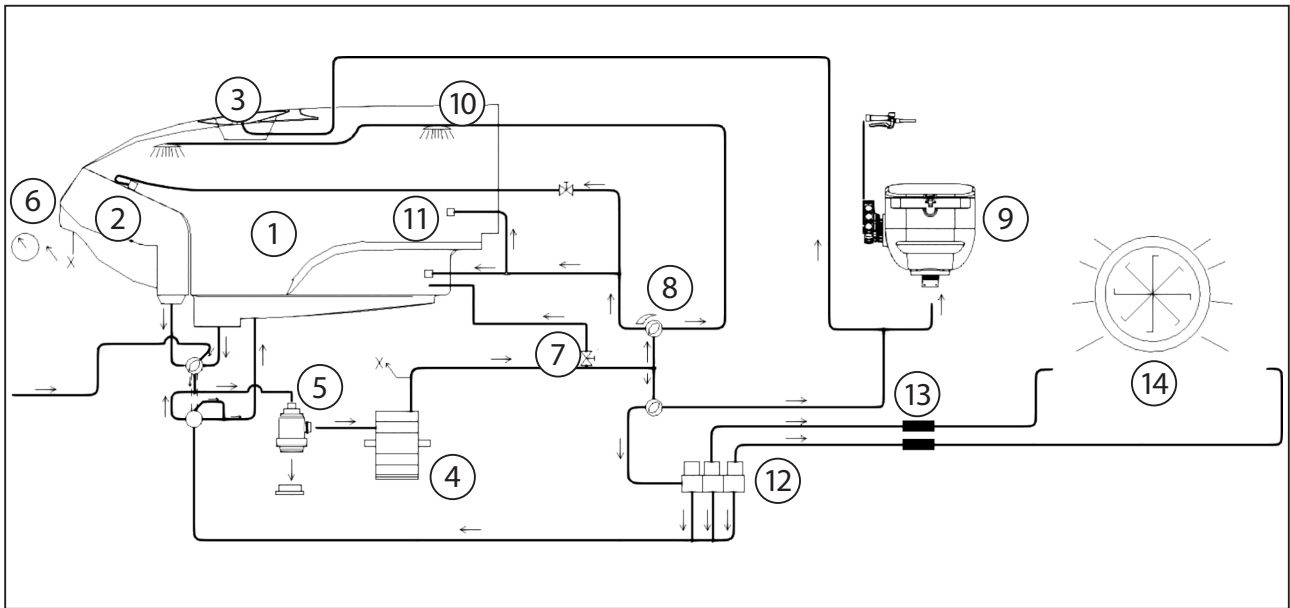

- | | |
|------------------------------------------------|-------------------------------|
| 1. Main tank | 8. Manifold valves |
| 2. Rinsing tank | 9. TurboFiller |
| 3. Powder mixer or bottle cleaner (optionally) | 10. Rinsing nozzles |
| 4. Pump | 11. Ventury agitation nozzles |
| 5. Suction filter | 12. Operating unit |
| 6. Manometer | 13. Inline filters |
| 7. Safety valve | 14. Spray line |

3 - Description

Circuit Diagram ZENIT

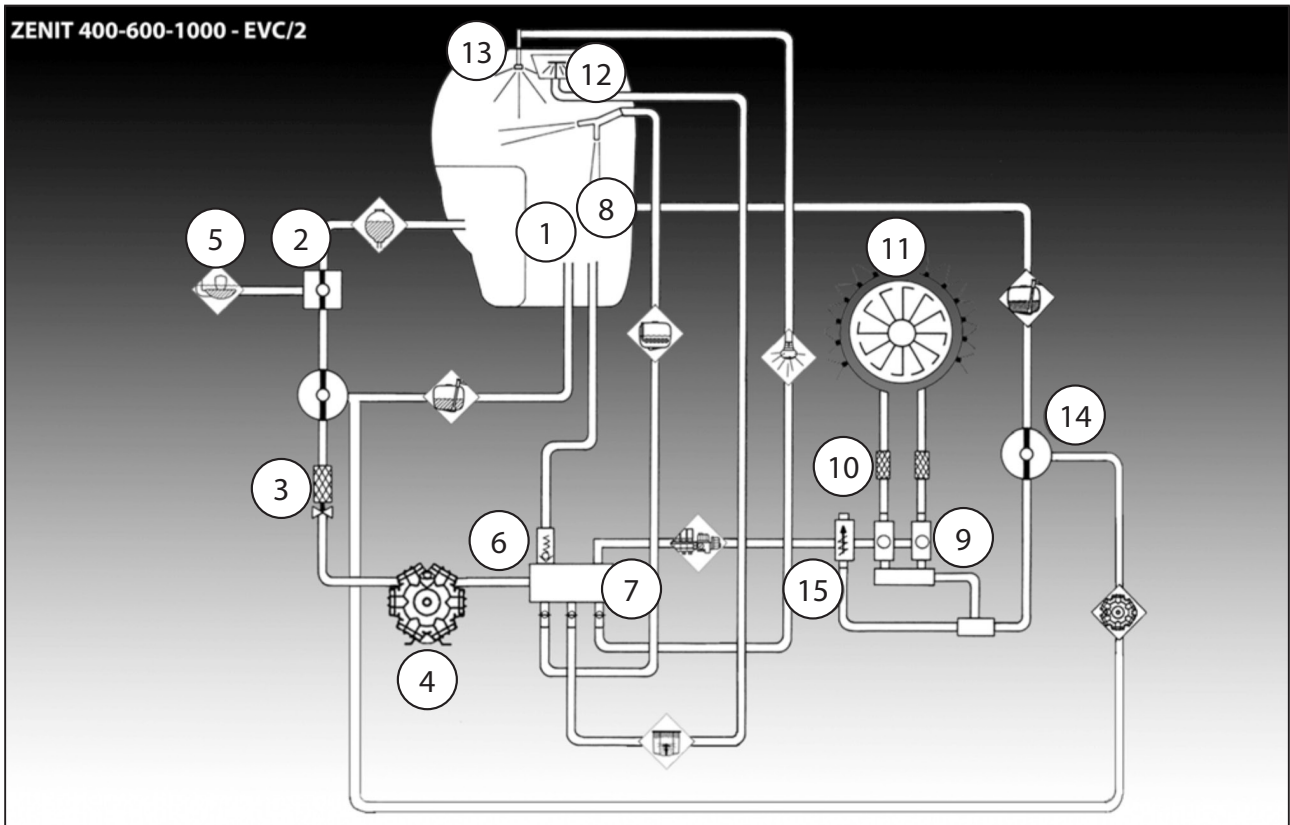

- | | |
|-----------------------------|----------------------------------|
| 1. Main tank | 9. Section valves |
| 2. Suction MANIFOLD (black) | 10. Pressure filters |
| 3. Suction filter | 11. Fan and nozzles |
| 4. Pump | 12. Powder mixer |
| 5. External filling | 13. Nozzle for internal cleaning |
| 6. Safety valve | 14. Return Manifold (Blue) |
| 7. Pressure collector | 15. Pressure regulator |
| 8. Agitation | |

Circuit configuration can vary according to local legislation and standards, e.g. dump valve.

Suction filter

The suction filter is located underneath the three-way suction valve.

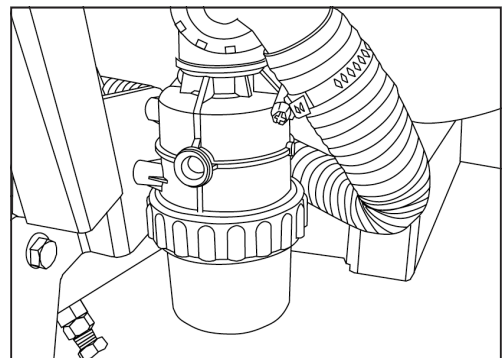

3 - Description

Circuit Diagram MERCURY

The operating units available for HARDI MERCURY machines are: MC/2, BS/2, BKC/2 y CB/2.

1. Main tank
2. Int./ext.source selector
3. Suction filter
4. Pump
5. Plug for filling device
6. Safety valve
7. Pressure distributor
8. Valve for spray gun
9. Pressure agitation
10. Return chamber
11. Operating unit
12. Spray arcs

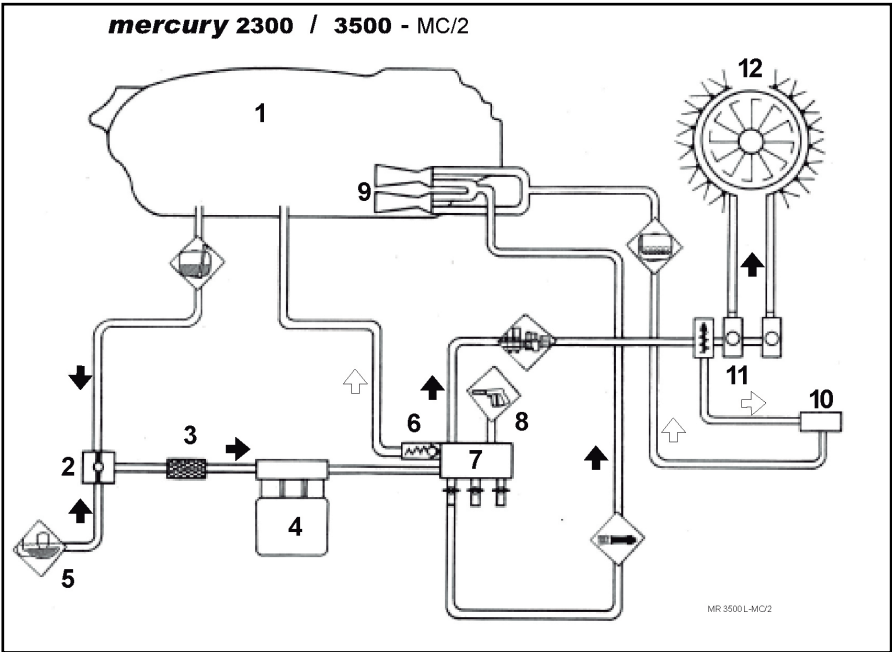

1. Main tank
2. Int./ext.source selector
3. Suction filter
4. Pump
5. Plug for filling device
6. Safety valve
7. Pressure distributor
8. Valve for spray gun
9. Pressure agitation
10. Return chamber
11. Operating unit
12. Spray arcs
13. Pressure filters
14. Powder mixer

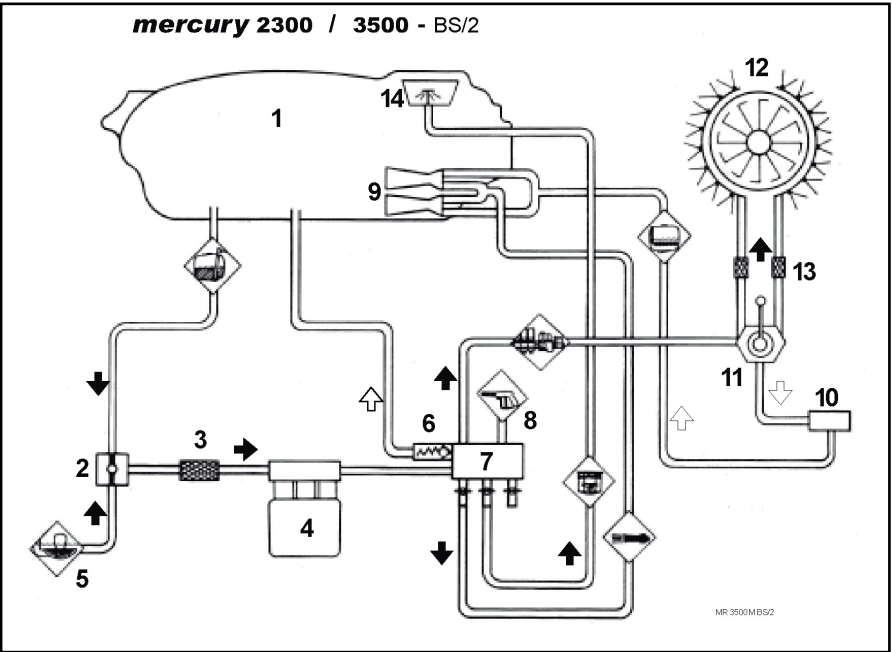

3 - Description

1. Main tank
2. Int./ext.source selector
3. Suction filter
4. Pump
5. Inlet for filling device
6. Safety valve
7. Pressure distributor
8. Valve for spray gun
9. Pressure agitation
10. Return chamber
11. Operating unit
12. Spray arcs
13. Pressure filters
14. Powder mixer

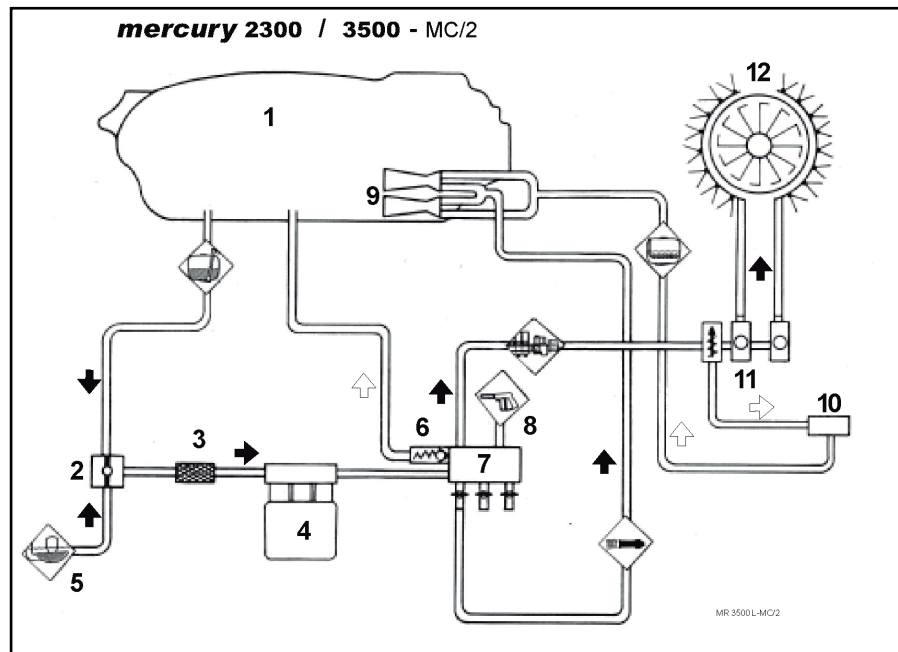

1. Main tank
2. Int./ext.source selector
3. Suction filter
4. Pump
5. External source
6. Safety valve
7. Pressure distributor
8. Valve for spray gun
9. Pressure agitation
10. Return chamber
11. Operating unit
12. Spray arcs
13. Pressure filters
14. Powder mixer
15. Tank flushing nozzles
16. Suction Manifold
17. Return Manifold
18. Clean water tank

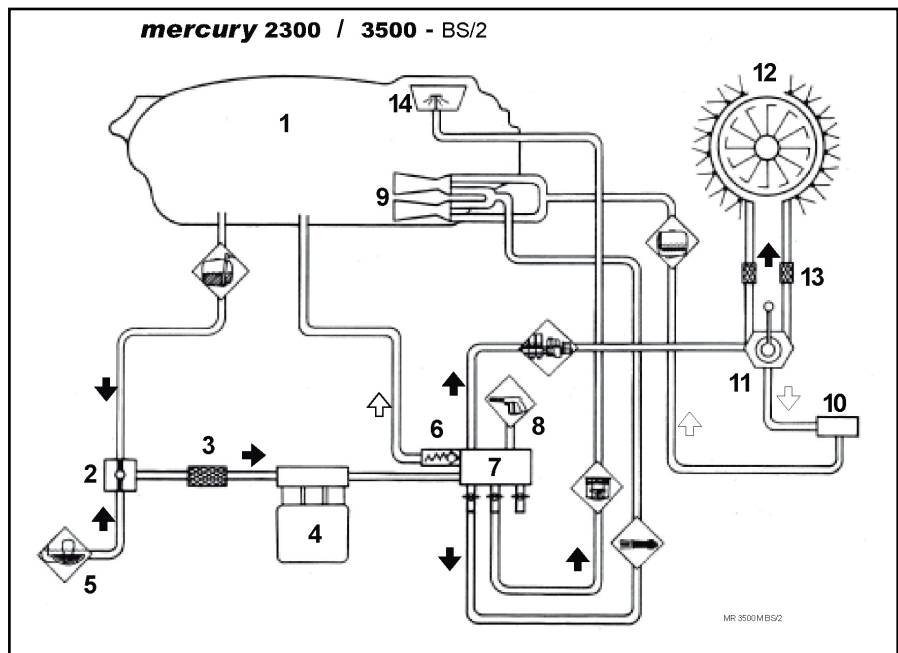

3 - Description

Safety valve

It is made of cast iron and is situated at the front of the machine next to the operating unit. From this manifold it is possible to activate the agitator and the rinsing nozzle for internal cleaning (optional), as well as the Turbofiller (optional) or powder mixer. Do only open the manifold valve in order to send pressure to the desired device, as in the example given: the Turbofiller.

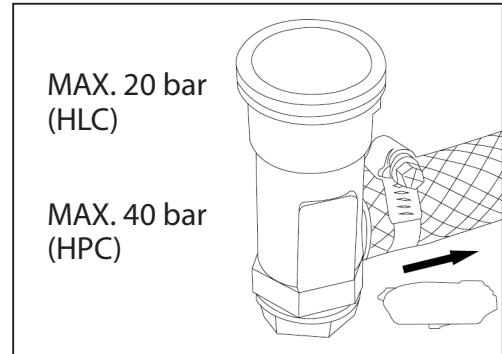

Safety Valve Activation

To make the fluid system work perfectly over time, it is good practice to regularly provoke opening of the safety valve. This prevents clogging and ensures proper function of the safety valve.

Turn all manifold valves to zero for 1 second, and the safety valve must pop.



Pressure manifold

It is made of plastic and is situated on the front of the machine next to the operating unit. From this manifold it is possible to activate the agitator and the rinsing nozzle for internal cleaning (optional).

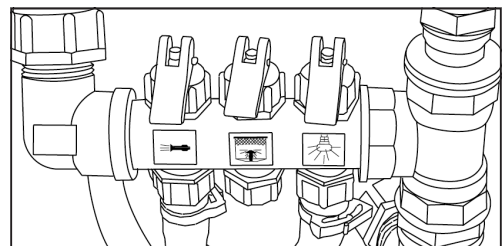

Suction and pressure pulsation dampers

The 321 pump is fitted with a pulsation damper on suction and pressure sides. The pressure side damper is pressurized. The dampers will reduce pulsations and secure an even flow from the pump.

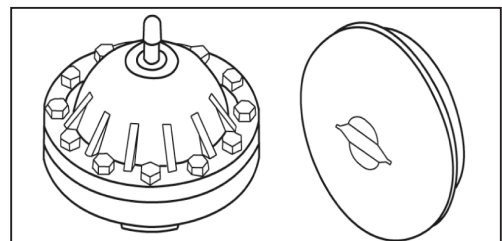

3 - Description

Agitator

At the front and on each side of the inside of the tank there are two ventury-shaped agitators. The agitators are activated by a valve on the pressure manifold.

Each agitator has a \varnothing 3mm nozzle (D).

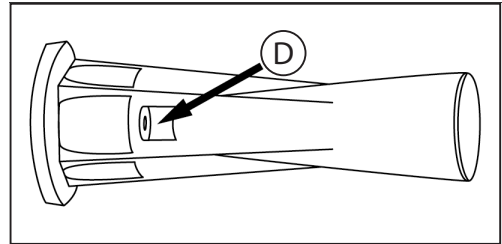

Operating unit

Your sprayer will be equipped with operating unit accordingly to country specifications.

The mistblower can be equipped with following types of operating units: MC/2, CB/2, SV and CB.

SA operating unit

Remote operated solenoid section valves with manual pressure regulation.

CB operating unit

Electrical remote pressure regulation, section valves by means of motor valves with pressure equalization device.

Filters

The pressure filters are located on the bumper next to the air outlet nozzle. In the HLC circuit the filters are made of plastic and in the HPC circuit they are made of brass.

All filters should be kept in good condition and cleaned regularly. Make sure you to use the correct combinations of filter and mesh size. The mesh size should always be less than the average of the total flow from the nozzles.

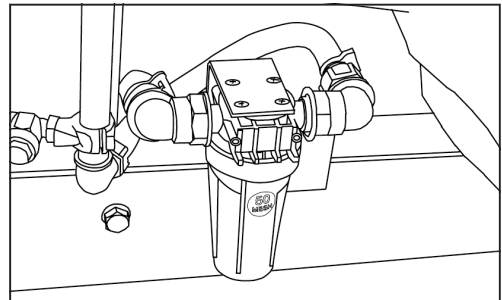

Powder mixer

This is used to rinse the filter basket in tank's filling hole when adding powdered products that do not dissolve properly or form lumps in contact with the water in the tank.

After using the powder mixer it must be disengaged as it uses a large amount of the available pump capacity.

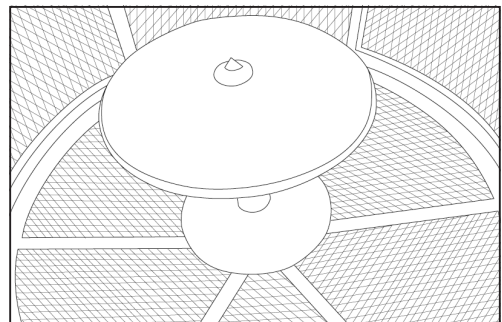

3 - Description

TurboFiller

Chemical inductor, TurboFiller (optional)

The TurboFiller allows the filling of both powder and liquid spray chemicals safe and conveniently when standing next to the machine.

The Turbofiller is neatly stowed under the main tank when not in use.



ATTENTION! Local legislation may require chemicals to be filled using a chemical inductor - Always follow local legislation in force at any time.

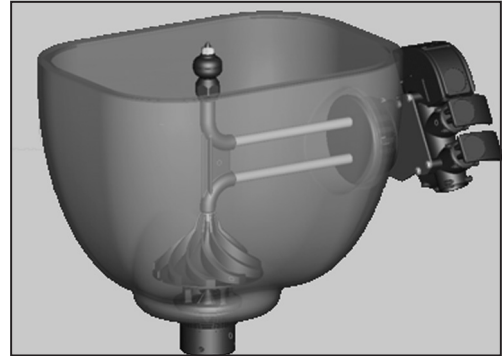

TurboFiller suction valve

The valve is used simultaneously with the TurboFiller. The valve has 2 settings: In the position A, indicated on the picture, it is closed. Open the valve when chemicals are to be filled into the TurboFiller.

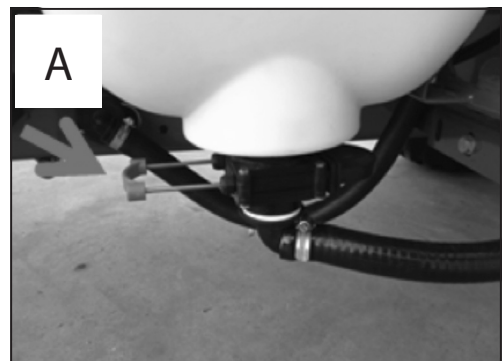

Turbo Deflector valve

This Turbo Deflector valve activates the Vortex flushing of the TurboFiller. Lift the lever to lock it in open position for continuous liquid rotation in the hopper.



Start Turbo Deflector

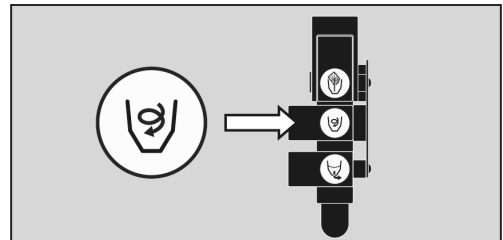

Chemical Container Rinsing lever

The upper lever is used for two purposes:

When the TurboFiller lid is open: For rinsing empty containers. Place the container over the rotating flushing nozzle in the middle of the TurboFiller to rinse the inside of the container.

When the TurboFiller lid is closed: Use the Chemical Container Rinsing lever to rinse the hopper when the filling of chemicals is completed.



Chemical Container Rinsing



DANGER! Do not press the lever unless the multi-hole nozzle is covered by a container as spray liquid may otherwise hit the operator.

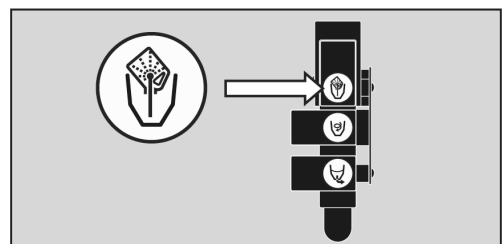

3 - Description

Axial blower units

Technical information

The air kits fitted on the HARDI ZATURN mistblowers are the AG820 and AG920, both having a polyethylene housing and fan blades made of a hardened synthetic material. Their aerodynamic shape offer a high quantity and perfect air distribution, low noise levels and low power consumption when adjusted to standard levels. The fan clutch enables a smooth start and stop.

EF820, EF920, AB750, AB820, AB920, AG820, AG920, IAG820, IAG920, SF65, SF85 and XF90

The air kits are fitted with a grid with air guides at the air intake, which forms the air flow before reaching the fan, to decrease the imbalance in the airflow. The fan is either 820 or 920 mm of diameter and is fitted with blades made of a hardened synthetic material. This reduces the power consumption to a minimum as a result of low material density.

There is a channel between the air intake and the cone of the air kit which increases the air speed through the outlet, and ensures that a high uniformity in air distribution is achieved.

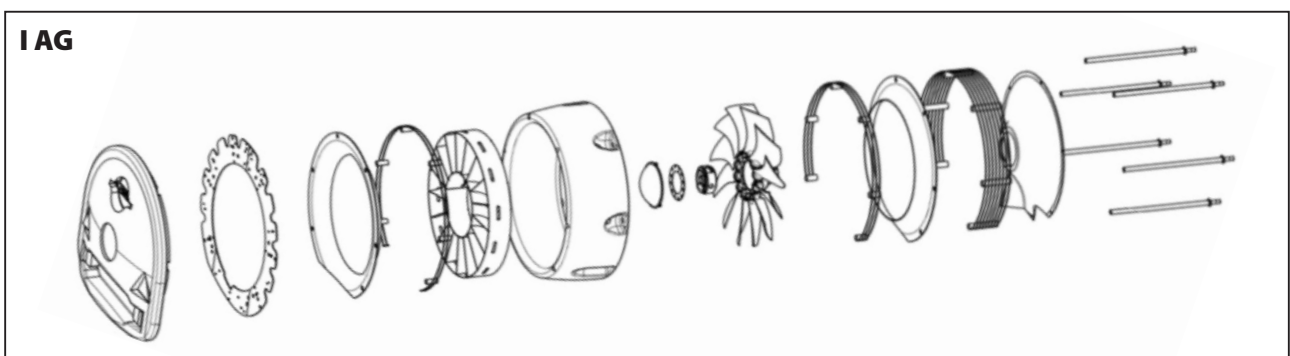
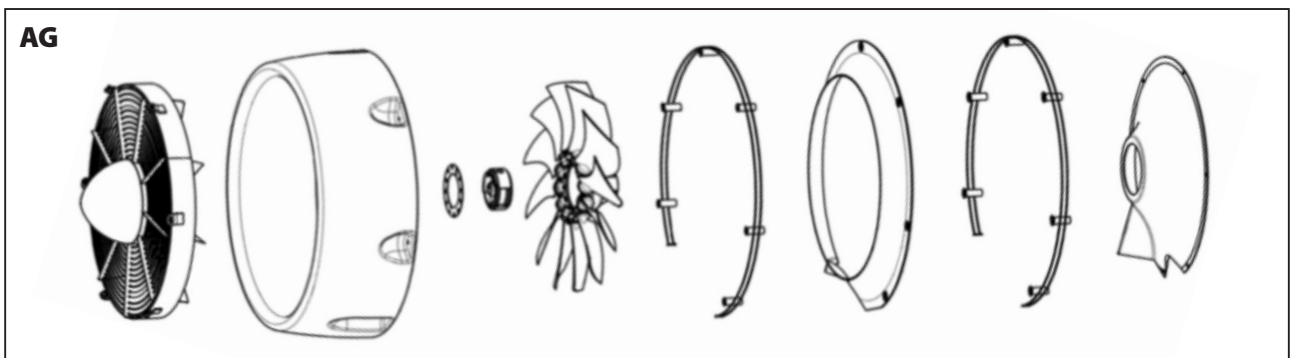
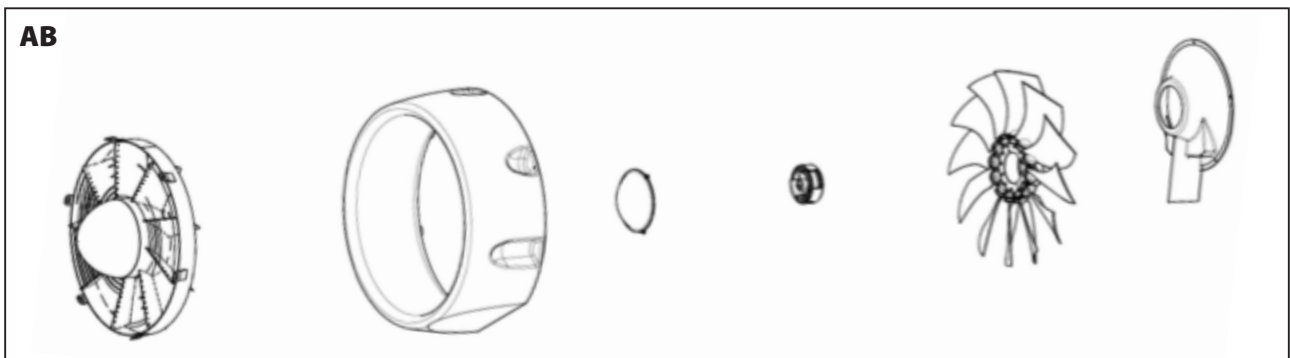

3 - Description

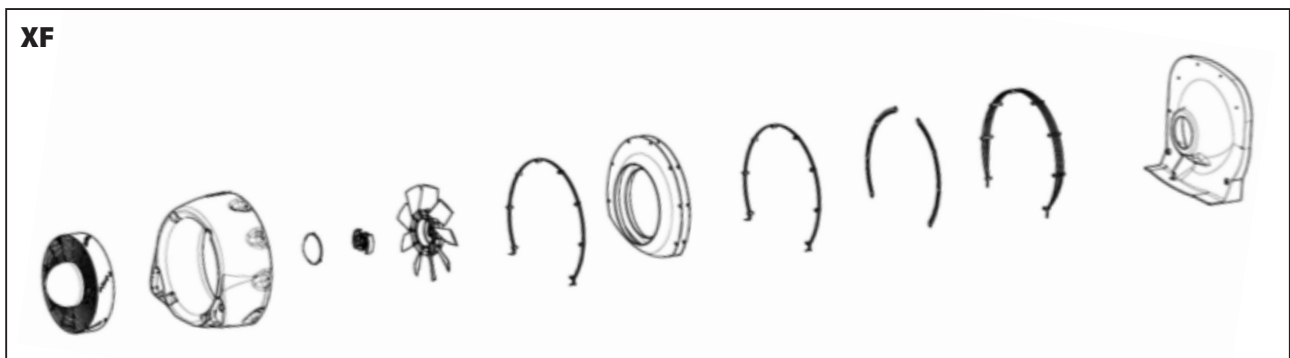
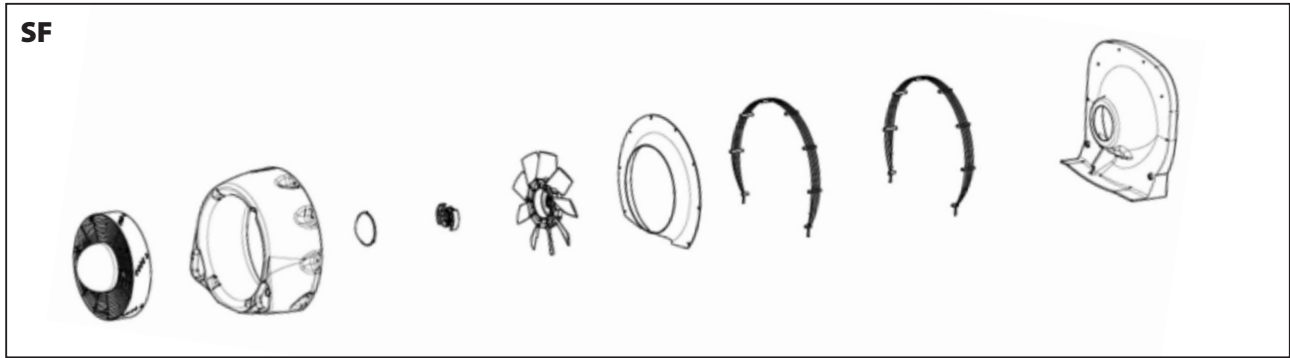

NEVER exceed 540 r.p.m. on the tractor P.T.O.! The fan may explode if overspeeded!



KEEP AWAY from the air inlets and outlets while the fan is on. Some objects may be shot out of the air outlet or a piece of clothing could be sucked into the air inlet.



The fan is the most dangerous part of the machine. Do not try to replace any of the parts without consulting your HARDI dealer first. Any service job or modifications on fan and air kit is to be carried out by your HARDI dealers qualified technicians.

3 - Description

Air flow for axial air kits

	Blower unit	Speed	Relationship	Fan diameter	Power		Air flow	
					kW	Hp	m3/h	cubic foot/minute
ZATURN	iAG820	1st low	1:3.5	820 mm / 32"	26	36	34.000	20.000
		2nd high	1:4.4		30	42	40.000	24.000
	AG820	1st low	1:3.5	820 mm / 32"	27	38	43.000	25.000
		2nd high	1:4.4		33	45	50.000	29.000
	AG920	1st low	1:3.5	920 mm / 36"	30	42	51.000	30.000
2nd high		1:4.4	36		50	60.000	35.000	
JUPITER/ MERCURY	SF65	1st low	1:3.5	820 mm / 32"	41	56	55.000	32.000
		2nd high	1:4.4		40	55	65.000	38.000
	SF85	1st low	1:3.5	920 mm / 36"	37	51	72.000	42.000
		2nd high	1:4.4		44	60	85.000	50.000
	XF90 Low pitch	1st low	1:3.5	920 mm / 36"	37	50	70.000	41.000
2nd high		1:4.4	42		58	80.000	47.000	
XF90 Medium pitch	1st low	1:3.5	920 mm / 36"	44	60	85.000	50.000	
	2nd high	1:4.4		52	70	100.000	60.000	
ZENIT	AB820	1st low	1:3.5	820 mm / 32"	25	35	36.000	21.000
		2nd high	1:4.4		32	44	43.000	25.000

Protective grid

The air kits are fitted with protection grids. They are fundamental for avoiding accidents and for stopping foreign bodies from getting inside the air kit.



Tractor driver's seat is the intended working place during operation.



This product is designed to be used in agriculture orchard application.





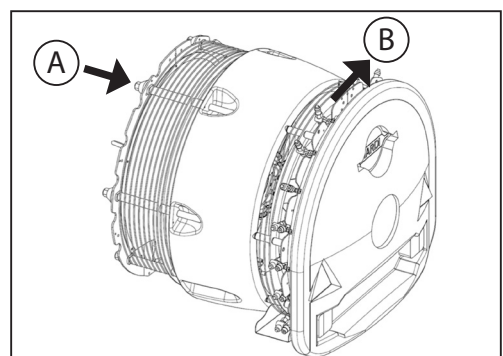
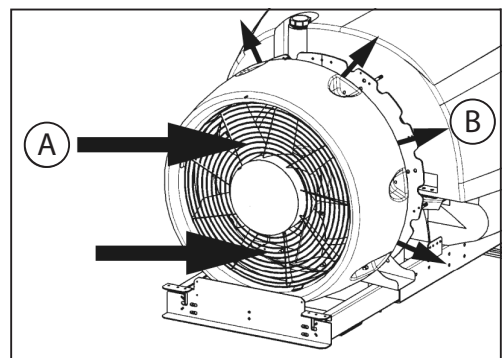

Do never pass 540 rpm on tractor PTO

Invers air inhalation

A is air inhale and **B** is air out let



3 - Description

-  DANGER! It is strictly forbidden to use the blower unit without the protective grid.
-  DANGER! Do not approach the fan when in use.
-  DANGER! Do not introduce foreign bodies through the grid, regardless of whether the fan is in use or not.
-  DANGER! During the working day, protect your hearing from the noise produced with EN 352-1:1992 approved hearing protection or similar.
-  DANGER! If you notice vibrations or unusual noise, stop the fan immediately and consult your HARDI dealer.

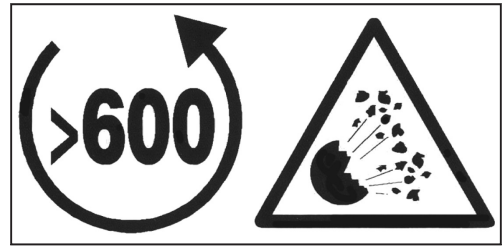

Deflectors

Axial air sprayer known as well as air sprayers can optionally be equipped with mentioned deflectors.

Deflectors contribute to an increased efficacy in the spray job, as they reduce drift, and provide direction of air and spray mist in direction to the target, according to adjustment.

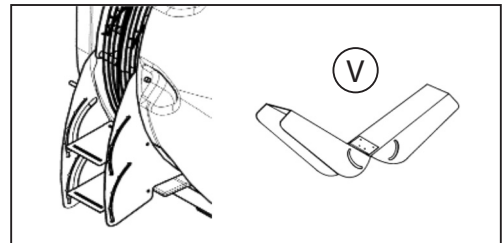

Top

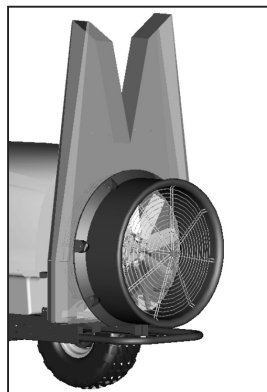

DUO P



DUO T



JET

3 - Description

Gearbox

The AG820 and AG920 are fitted with a 2-speed gear box with a neutral position. The front and lower area of the gear box are attached to the chassis. It is fitted with a speed selector that prevents from jumping out of gear when engaged.

The speed ratios are following:

1st speed, low gear: 1 – 3.6

2nd speed, high gear: 1 – 4.4

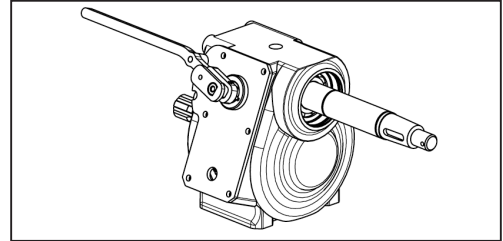

Fan

The axial fan has synthetic impact proof blades resistant to high and low temperatures as well as chemical products.

The blades have 3 different angle settings to adjust the air flow. To change the angle, see the section 'adjusting the fan'

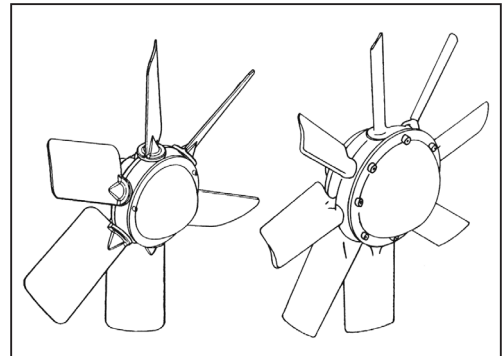

Specific for SF and XF axial fans

After changing pitch, the fan needs to be balanced.

Position P1 (35°) must coincide with C1, in other words the first groove on the fan blade with the first groove on the crown.

Second position P2 (40°, standard factory setting) must coincide with C2.

Third position P3 (45°) must coincide with C3.

After changing pitch, the fan must be calibrated, either at the factory, or by a certified dealer or workshop, under the instructions of the factory (HARDI).

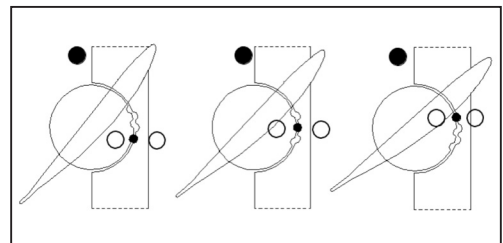

Centrifugal Blower Units (Turbines)

General information

The blower unit is located at the back of the machine. It contains a gearbox unit, blanking plate, casing, outlet hoses and nozzles, turbine and clutch.

There are two different turbine models: the steel model assembled in P540 and P540D centrifugal blower units, and the aluminium model assembled in HF600 blower units.



ATTENTION! The clutch is one of the most important parts in the blower unit in terms of safety. Make sure that it is in perfect conditions (i.e. that it is not blocked, etc.). Otherwise, it could cause the blower unit to explode.

HF540 (TS3 P540 / TS6 P540 Single)

HF540D (TD3-P540 Double)

HF640D (TD3-P640 Double)

The air kit should adapt to the requirements of the booms' width and crop in order to give the best application results. The following section gives more details about the different pneumatic air kits available.

The letters HF***D means High Flow and Double, respectively. They have a polyethylene casing and turbines of 540 mm / 21" or 640 mm / 25" diameter.

Components

- | | |
|---------------------------|------------------|
| A. Grid | D. Steel turbine |
| B. Polyethylene crankcase | E. Gearbox |
| C. Clutch | F. Chassis |

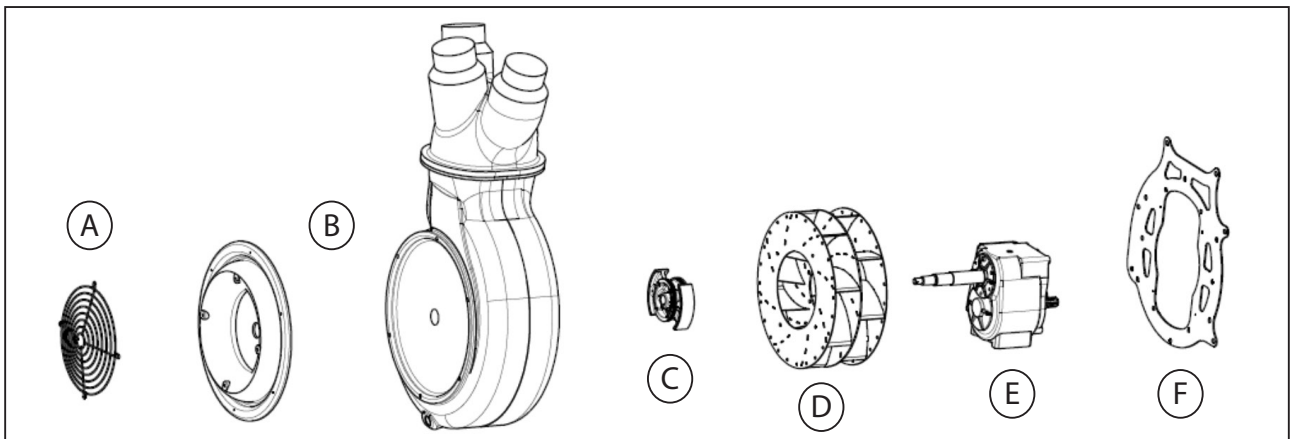

DANGER! UNDER NO CIRCUMSTANCES should you exceed 540 r.p.m. from the tractor PTO as there is a serious danger of air kit explosion.



DANGER! STAY CLEAR of the air inlet and outlet while the turbine is in use. Foreign objects could be expelled from the air outlet or parts of clothing could be sucked into the air inlet.



WARNING! The blower units are the most dangerous part of the machine. Do not attempt to alter any of its components without checking with your nearest distributor first. Manipulating blower units to change their characteristics should only be carried out by qualified personnel that has been expressly authorised by the manufacturer.





3 - Description

Air flow of HF540, HF540D and HF640D centrifugal turbines

Blower unit	Speed	Relationship	Turbine diameter	Power		Air flow	
						m3/h	cubic foot/minute
HF540	1st low	1 - 6.6	540 mm	12 Kw	16 HP	8.000	4700
TS3 P540 / TS6 P540	2nd high	1 - 7.8		16 Kw	21	10.000	5900
HF540D	1st low	1 - 5.7	540 mm	14 Kw	19	11.000	6500
TD3-P540	2nd high	1 - 6.6		22 Kw	29	15.000	9000
HF640D	1st low	1 - 4.5	640 mm	24 Kw	33	27000	16000
TD3-P640	2nd high	1 - 5.7		36 Kw	49	37000	22000

Protective grid

The blower units have protective grids fitted to the air inlets. They are essential for avoiding accidents and preventing small stones, leaves or other foreign bodies from entering the blower unit that could cause damage inside the grid.

-  DANGER! It is strictly forbidden to use the blower unit without the protective grid.
-  DANGER! Do not approach the fan when in use.
-  DANGER! Do not introduce foreign bodies through the grid, regardless of whether the turbine is in use or not.
-  DANGER! During the working day, protect your hearing from the noise produced with EN 352-1:1992 approved earmuffs or similar.
-  DANGER! In the case of vibrations or knocking, stop the turbine immediately.

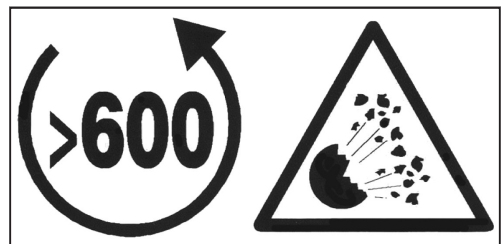
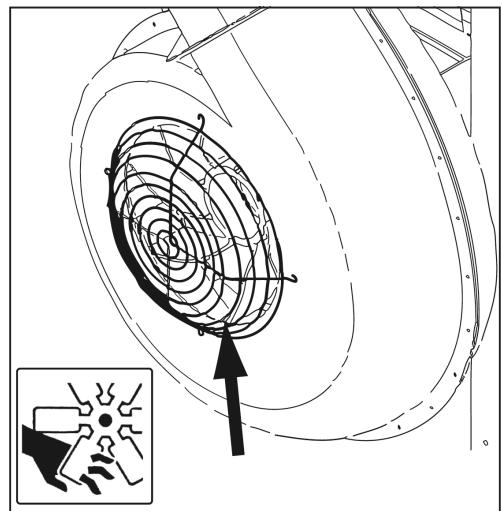

3 - Description

Gearbox

The HF540, HF540D and HF640D blowers have a two-speed gearbox with neutral position.

Upper pos: High speed

Middle pos.: Neutral

Lower pos.: Low speed



DANGER! Do not attempt to engage or disengage the speed with the PTO in operation.

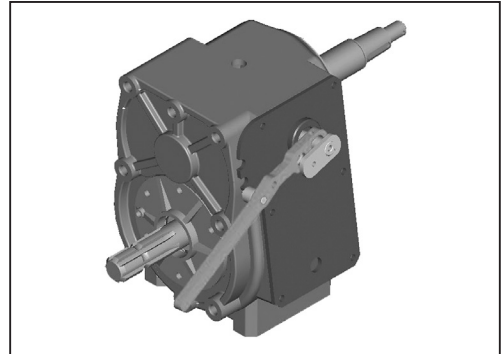

HF540, HF540D and HF 640D Turbines

The HF540 and HF540D centrifugal blower units contain a galvanised steel turbine. The difference between the single model and the double model is that the double provides the same power as two single turbines combined.

The position of the blades in this type of turbine is fixed. Their angle cannot be changed like in axial fans.

The turbines are allowed to turn at a maximum of 540 r.p.m.

The clutch is at the centre of the turbines, which ensures smooth start-up and stops - see section "Clutch" for further information.

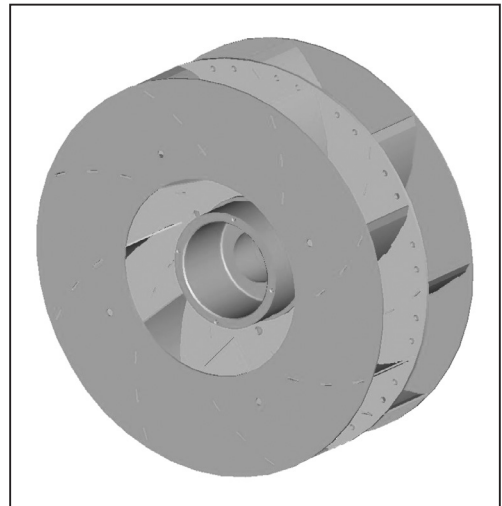

Clutch (All blower types)

The clutch is integrated at the centre of all the fan models and will ensure a smooth start-up and stop of the fan. The clutch design may vary from model to model, but the functioning and maintenance is the same.



WARNING! The clutch is a vital part in the blower unit. Poor condition could cause the blower unit to break or explode.

The condition of this part should be regularly checked. Please carefully read the section on its 'Maintenance'.



DANGER! The clutch is one of the most important parts in the blower unit in terms of safety. Make sure that it is in perfect conditions (i.e. that it is not blocked, etc.) Otherwise, it could cause the blower unit to explode.



3 - Description

Equipment

Ring drawbar

This is attached near the tractor's rear axle. Before engaging the tractor PTO (Power take-off), make sure the drawbar pin is firmly in place and secured, and that the tractor's wheels do not touch the mistblower when turning.

There needs to be a CV joint on the side of the tractor. The length of the drawbar can be adjusted (see section "Adjusting the length of the drawbar").

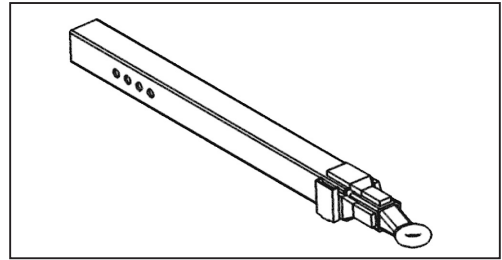

Fork drawbar

This is attached to a transversal hole boom fitted to tractor's lift arms. Before engaging the tractor PTO make sure the drawbar pin is firmly in place and secured, and that the tractor's wheels do not touch the mistblower when turning.

A CV joint is not required. The length of the drawbar can be adjusted (see section "Adjusting the length of the drawbar").

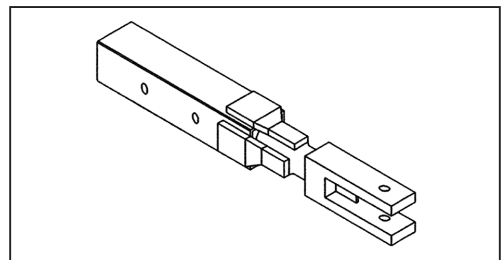

Turnable drawbar

This is attached to the tractor's lift arms. Before engaging the tractor PTO make sure the diameter of the shaft fits the ball couplers at the lift arms. Also make sure to fit the securing pins and check that the tractor's wheels do not touch the mistblower when turning.

This type of coupling allows narrow turns, if a CV joint is fitted at the mistblower's power intake. The length of the drawbar can be adjusted (see section "Adjusting the length of the drawbar").

The turnable drawbars, model X and Y are fitted under the rear axle of the tractor, a common arrangement on smaller fruit orchard models of tractors. It is important that the two stop bolts are tightened up, to avoid slackening.



Angle transmission shaft fitted. Tight turns with PTO engaged may damage the transmission shaft, the pump crank shaft and induce huge vibrations through the gearbox. This may lead to severe damages on gearbox and/or fan.

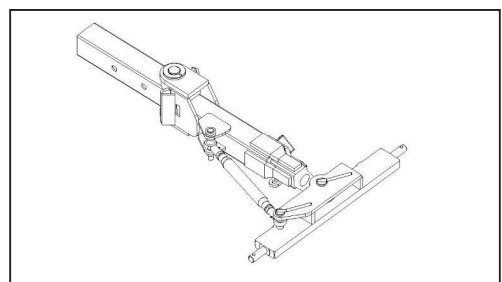
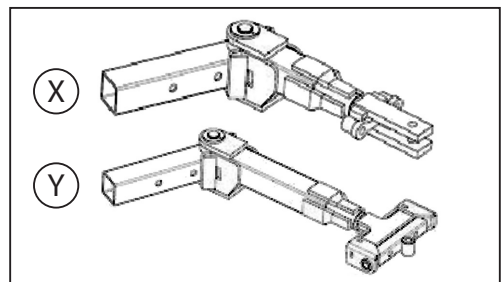
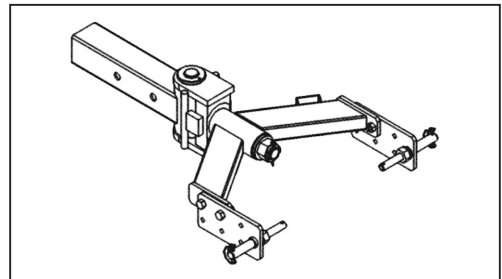

Self-steering drawbar.

3 - Description

Wedges

The wedges are located on the left-hand side of the machine. They should always be carried in their support so they are available when required.

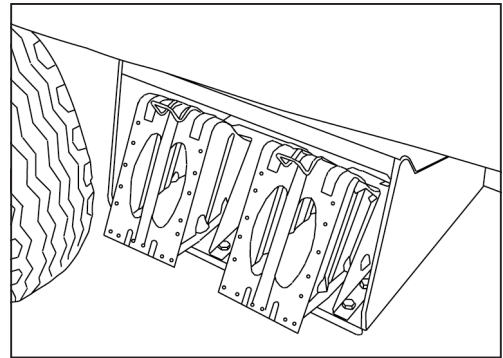

Light kit

The light kit can be fitted to the rear bumper at the fan. They are connected via a universal plug adaptable to any make and model of tractor.



Lights must be used when driving on public roads both inside and outside urban areas. If any of the components should break, they should be replaced immediately. In order for the device to work, connect the plug to the light socket on the tractor.



Booms

Hardi offers 4 booms programs, LINER, ATLAS, BOXER or CRONOS.

The booms are equipped with pneumatic or hydro pneumatic spouts or OPTIMUS drop legs.

If hydraulic folding and adjustment is offered, it is direct to the tractor or electro hydraulic, see separate chapter.

The LINER boom

Manual adjusted support to position spray device either behind the turbine with the FIX system, or on each side of the turbine unit, the START system. Both can be combined to START FIX boom system.

Optimally, last mentioned can be offered with hydraulic side adjustment.

An in-between row solution.

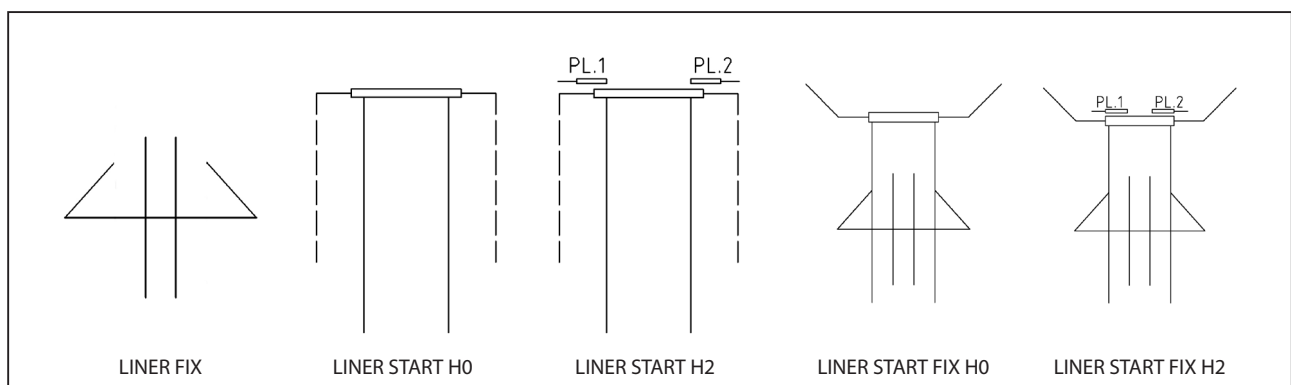

3 - Description

The ATLAS boom

The boom program is divided in following versions: START, AGILE and SOLID.

According to specification, hydraulically adjusted , The SOLID addition is as well offered in a GV version, Geometry Variable.

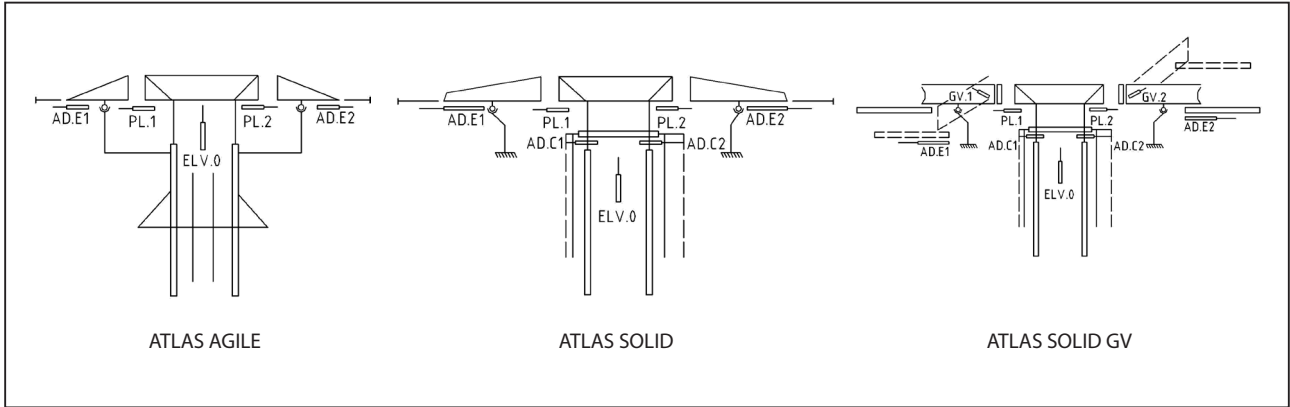

The BOXER boom

3 additions: START, AGILE and SOLID

Hydraulically adjusted, the first has a light structure and SOLID has a reinforced and wider boom structure.

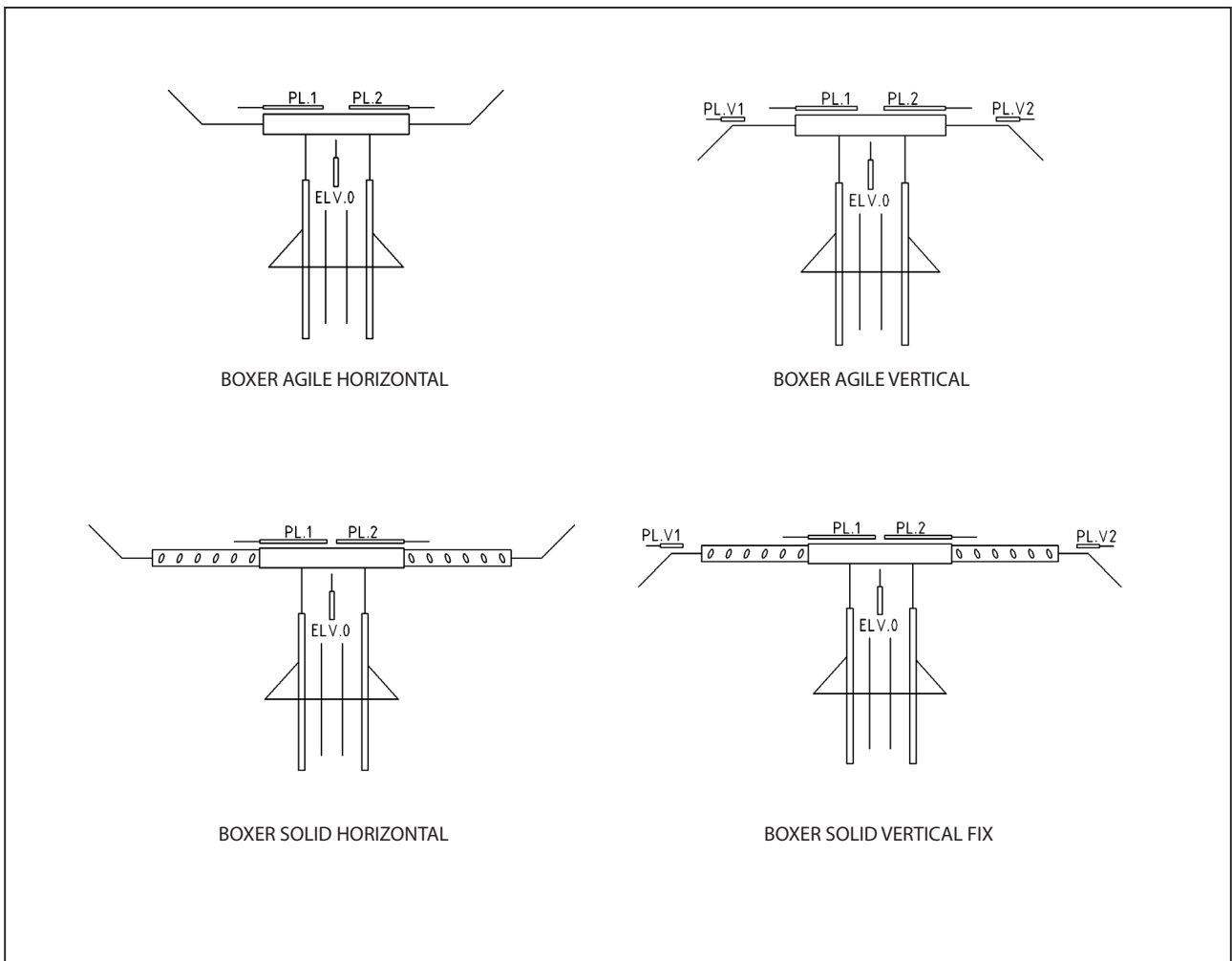

3 - Description

The CRONOS boom

The boom program is divided in the following versions , SOLID, RIDER and VARIA

According to specification, hydraulically adjusted. Common for all booms is the rubber bump absorber in the boom wing. SOLID has no trapeze suspension. RIDER & VARIA have trapeze suspension.

All 3 versions of the CRONOS boom are offered in FIX boom wing (no angling – Tilt function in boom wing, or GV boom wing (Geometry Variable) allows Tilt up in positive 60° and negative -25° down to adapt to the target.

The inner spray device can optionally be hydraulically adjusted but the “ADAPTA” as well as the outer device can optionally be hydraulically adjusted

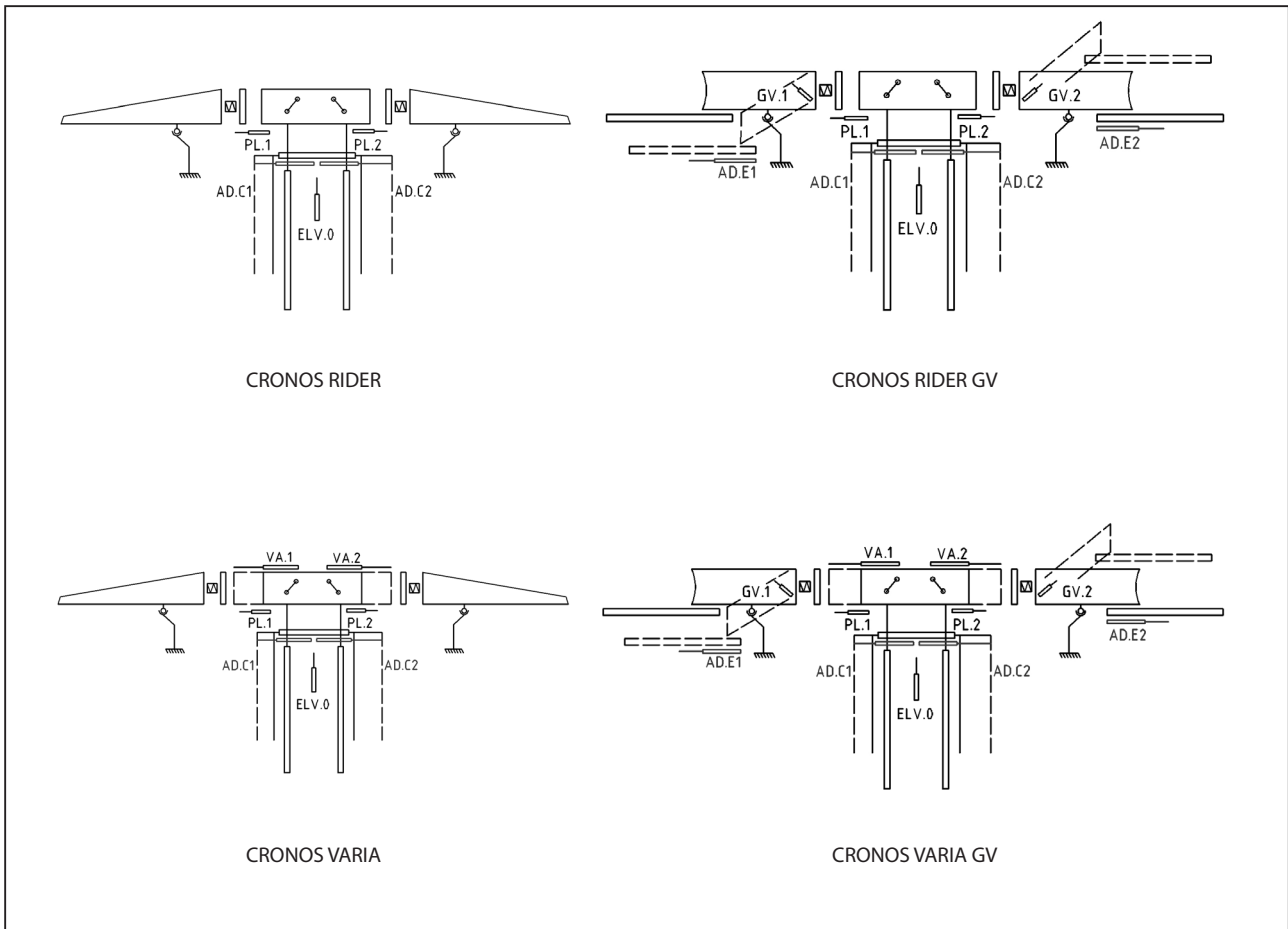

3 - Description

Break away clutch

All boom wings are equipped with brake away clutches, in vertical as well as horizontal direction, according to boom specifications.

The clutch is adjusted according to boom weight and field conditions.

Soft and loose the clutch. Loosen counter nut A, loosen bolt B. To tighten clutch to be harder; loosen nut A, tighten bolt B. Tightness must never be harder than 15 Kg / 30 pounds, or the outer boom wing will open / activate the boom clutch.

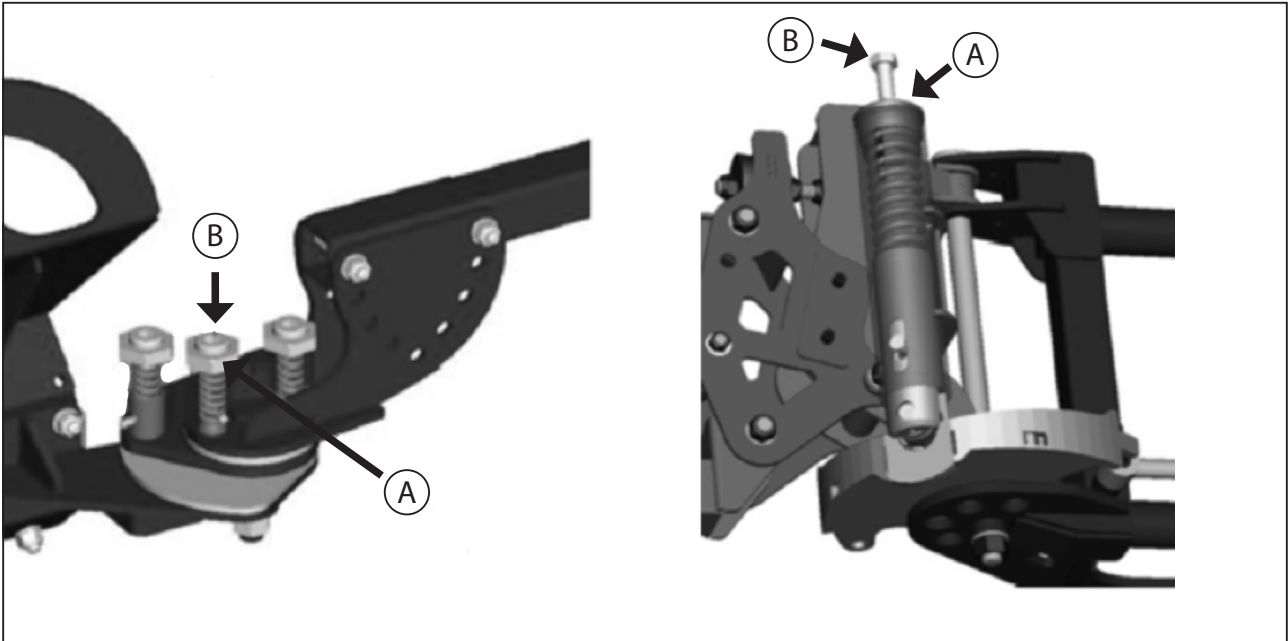

Particularly for CRONOS boom

The boom's parts are equipped with a non-adjustable rubber sustention B, to absorb the knocks from driving in the field. Be sure that the rubber parts are intact, and bolts are in place with the part well threaded over the bolt.

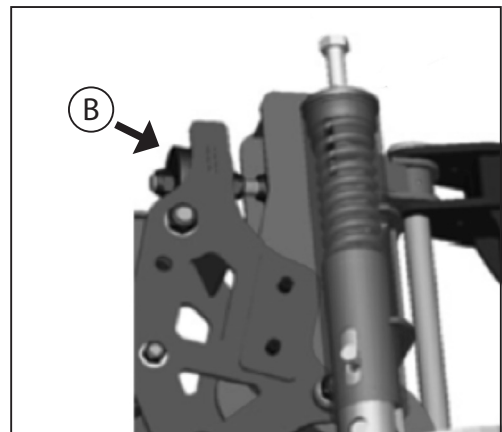

3 - Description

The RAIL boom

The boom is offered from 7 to 13 m, hydraulically folded, fitted with pneumatic or hydro pneumatic spray spouts. Booms up to 7 m are cross folded, larger booms are bi-articulated, and folds parallel to the sprayer tank.

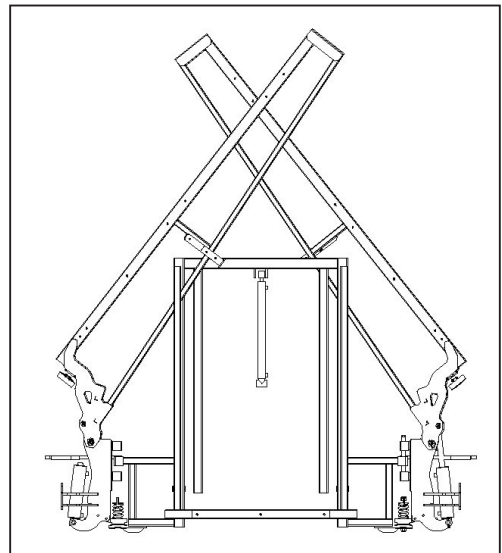
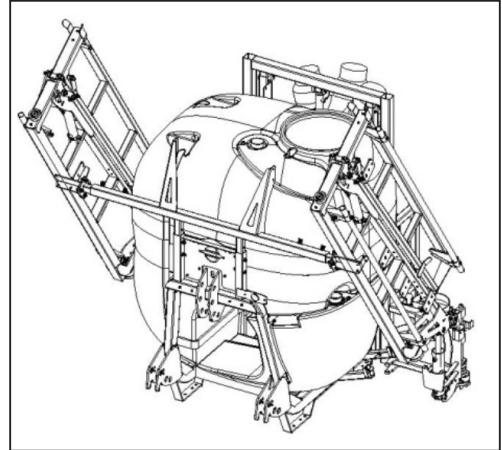

3 - Description

OPTIMUS system provided as Hydro pneumatic system or pneumatic system

The OPTIMUS application system allows individual air adjustment per each spout.

The spout can be completely closed, as well as the outlet can be narrowed, in order to speed up the air, and increase the penetration in the crop.

The droplet size of the hydropneumatic system atomiser is regulated by the choice of the nozzle.

The pneumatic system, has as well a nozzle to calibrate the flow, but the droplet size is generated by the air speed, the higher the speed, the smaller droplet size.

The system provides the required droplet size and air conduction to the target. The most delicate and difficult part of the vine, the grape cluster, is safely treated throughout the season, due to a very easy and quick calibration with the OPTIMUS system.

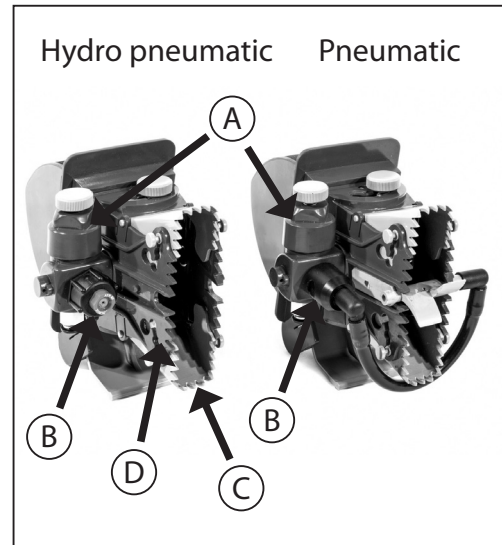

- A. Non-drip valve
- B. Nozzle
- C. Air guide (angle)
- D. Air vane adjustment, spread it slightly to the side, and move the air guide C

OPTIMUS 15

A polyethylene air body holds the spouts.

OPTIMUS 15 has 1 airstream right in the middle of the spout.



3 - Description

OPTIMUS 35

A polyethylene structure protects the front of the spouts. There are 3 air streams in each spout.

The 3 air streams , 1 in the centre of the spout, one in the front and one behind it, ensure that the droplets reach the target efficiently.

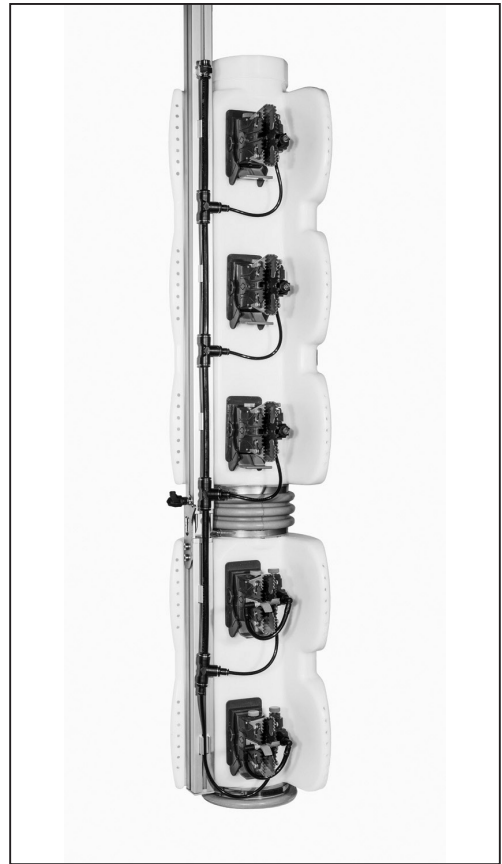

OPTIMUS 55

Recovery panels collect the product that is not fixed on the canopy, returning it to the tank.

Recovery panels have 5 air streams each to drive droplets to the target, as well as to provide a "tunnel effect" and avoid drift, even on windy days.



4 - Starting up

4 - Starting up

General information

Unloading the mistblower from the truck

When loading or unloading the mistblower to/from a lorry by using a lever and pulley or a crane, use the suspension points shown on the diagram and make sure the straps used are strong enough.



DANGER! Nobody must stand below or next to the machine during loading or unloading.

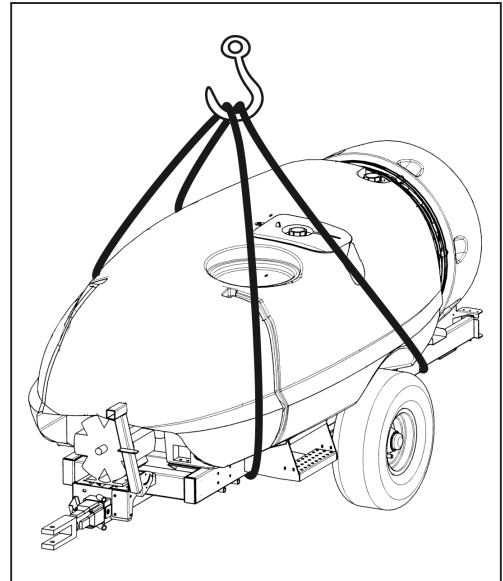

Before starting up for the first time

Although the surface of the metallic parts of the mistblower have been coated with a strong, protective product, we recommend you to apply a layer of anti-corrosion oil (e.g. CASTROL RUSTILLO or SHELL ENSIS FLUID) to all metal parts to avoid chemical products from discolouring the enamel, as well as to ease future cleaning.



ATTENTION! This treatment should be carried out whenever the protective layer wears off.

Counterweights

Check if it is necessary to place a counterweight on the front of the tractor, to increase the stability and steering performance.

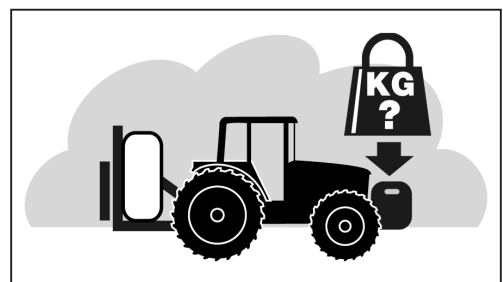

Mechanical connections

Adjusting the drawbar length

1. Place the jockey wheel in the position indicated on the photo.
2. Loosen the three bolts (A), located in the area where the drawbar is connected to the chassis.
3. Remove the bolt (B).
4. Adjust the drawbar to the desired position.
5. Replace bolt (B), making sure that it passes through the holes in the chassis and the shaft.
6. Tighten the bolts (A) and the locknut again.

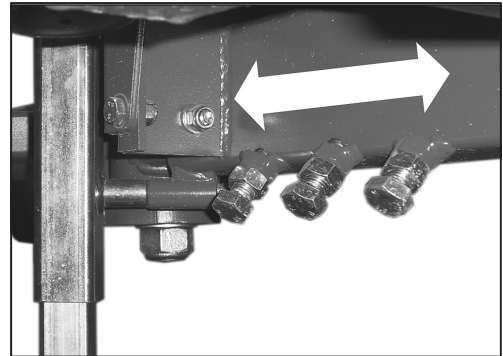

Jockey wheel

The jockey wheel allows the mistblower to be coupled to or uncoupled from the tractor. The illustration shows the position when the mistblower is detached from the tractor; when the mistblower is attached it will be stored on the left-hand side of the mistblower chassis using two pins.

The height of the machine can be adjusted by turning the handle (C).

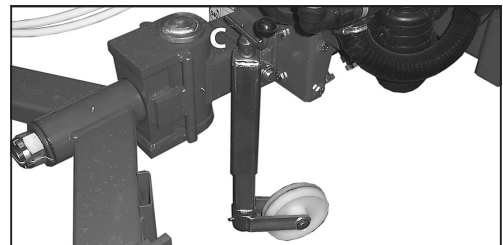

Connecting the fork drawbar

This is attached to the transversal hole boom mounted on the tractor lower links. Before connecting the PTO make sure that the coupler is correctly attached and secured, and that the tractor wheels do not touch the mistblower when turning. A transmission shaft with CV joint is not required.

Adjust the drawbar if necessary as explained in another section.

Connecting the ring drawbar

This is attached to the standard clevis-type coupler close to the tractor body. Before connecting the PTO make sure that the drawbar is correctly attached and secured, and that the tractor wheels do not touch the mistblower when turning. A transmission shaft with CV joint is required on the tractor's side. It is possible to adjust the length of the drawbar.

Adjust the drawbar if necessary as explained before.

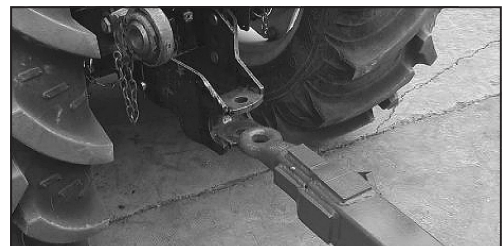

4 - Starting up

Connecting the turnable drawbars

This is attached to the tractor's lower linkage arms. Before connecting the PTO, make sure that the diameter of the pins matches the ball diameter on the lower links, that the snap locks are engaged and check that the tractor wheels do not touch the mistblower when turning.

Of the three hitch types, this is the one that permits the tightest turns, but a transmission shaft with CV joint is then required on the mistblower's power intake side. The length of the drawbar is adjustable.

Adjust the drawbar if necessary as explained.

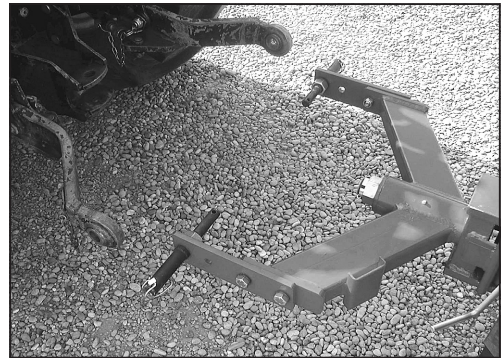

Lock device on turnable drawbar

The turnable drawbars are fitted with a lock device. Once down in forward and horizontal position, the pivoting effect is very limited. If the tractor has a weight 2 times the sprayer, it can be used in hilly conditions, where risk of tumbling the sprayer exists, but it is recommended to use the drawbar unlocked.



4 - Starting up

Hooking up the mistblower

If your mistblower has a semi-automatic quick hitch, follow the steps set out below:

1. Place the quick hitch boom in the hydraulic lift arms of the tractor.
2. Fit the lynch pins to secure the boom to the hydraulic lift arms.
3. Completely lower the boom with the tractor's hydraulic lever.
4. Reverse the tractor until it touches the chassis, placing this as near of the middle as possible.
5. Attach the top link to tractor and sprayer and adjust it by hand.
6. Raise the tractor's lower links with the hydraulic lever until the boom fits perfectly into place.
7. When the boom is correctly attached, the two hooks will close automatically and the equipment will be fixed to the tractor.
8. Put the safety pins of the semi-automatic quick hitch on to avoid the equipment from becoming detached during transportation or spraying.
9. Place the equipment at the height needed.
10. Adjust the top link until the equipment is completely perpendicular to the ground.

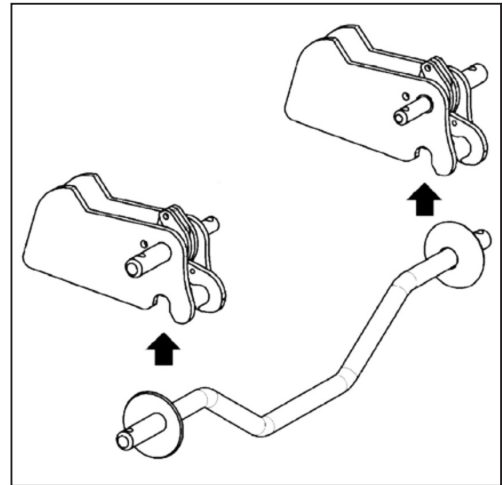

To detach the mistblower you should proceed in the following way:

1. Lower the tractor's hydraulic arms with the hydraulic lever until the equipment is touching the ground.
2. Pull the cable to release the boom from the semi-automatic quick hitch.
3. Loosen the top link.
4. Pull out the retaining pin from the top link to completely detach the mistblower.
5. Drive the tractor away slowly.

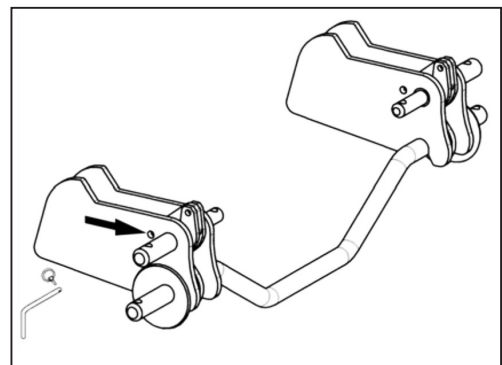

WARNING! The tractor's hydraulic lower links should be moved very gently to prevent damages or tipping over.

The mistblower towing

The equipment has to be towed by means of the hitch on its front. The same hitch is used to be coupled with the tractor. When carrying out the towing process, proceed with caution, ensuring at all times that there are no obstacles on the way to avoid a collision.

4 - Starting up

Disablement

The equipment has a security system, to prevent misuse. This system prevents the equipment from being coupled to the tractor.

Depending on the type of coupling available on the equipment, proceed as follows:

Type 1 / Type 4 / Type 7

To proceed with the use of the equipment, the padlock must be removed, located on the hitch, which prevents it from being coupled with the tractor.

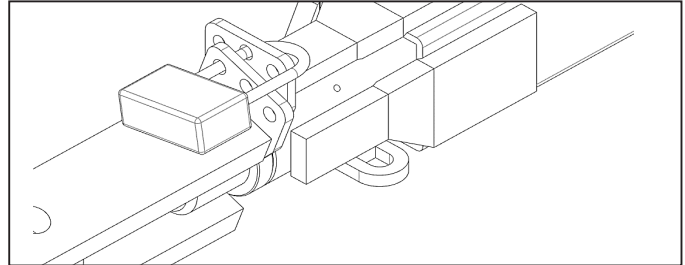

Once removed, put the padlock on the ring. This is the working position.

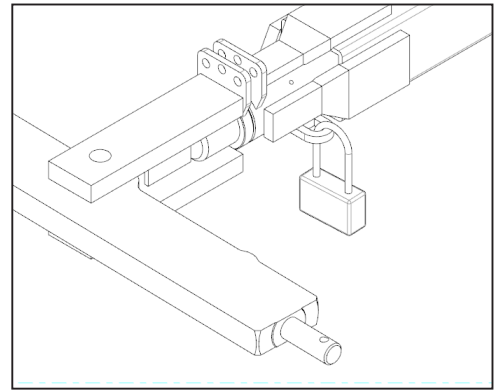

Type 2/ Type 3 have the same type

To proceed with the use of the equipment, the padlock must be removed, located on the hitch, which prevents it from being coupled with the tractor.

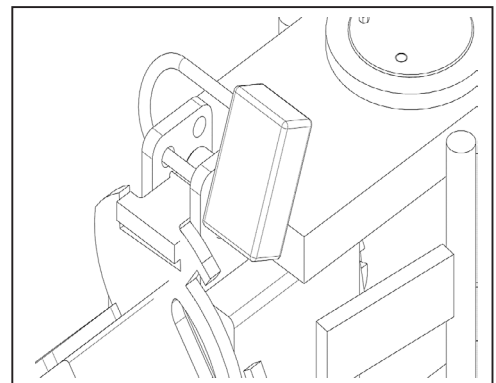
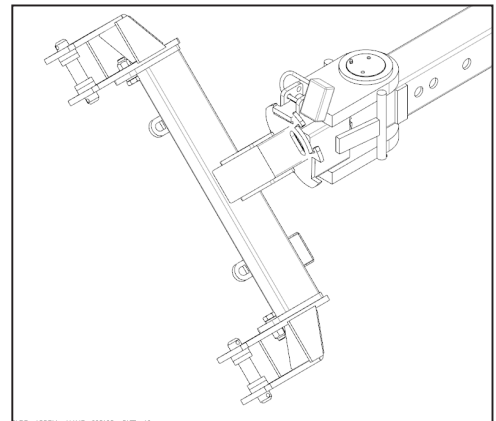

4 - Starting up

Once removed, put the padlock on the ring. This is the working position.

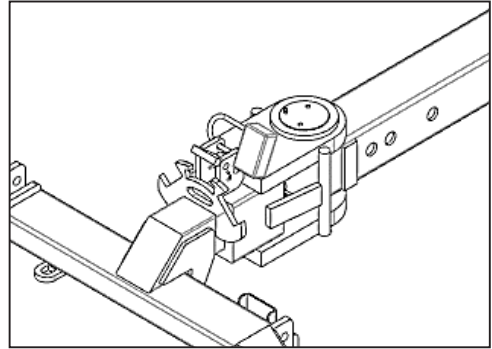
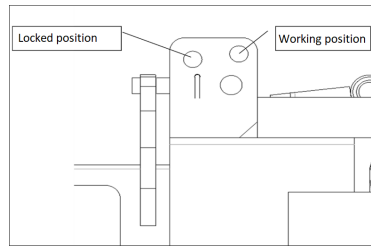

Type 5

To use the equipment, the padlock, located on the draft bar, must be removed and then the hitch ball must be placed.

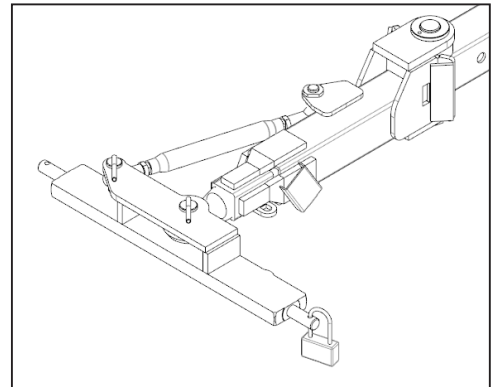

Once removed, put the padlock on the ring.

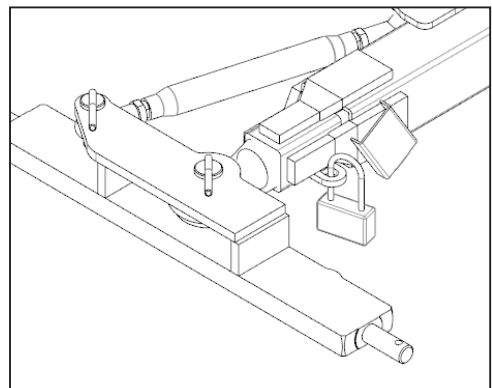

Standard Eye Ring Hitch & Type 8

To use the equipment, the padlock, located on the draft bar, must be removed and then remove the shaft on the eye trailer.

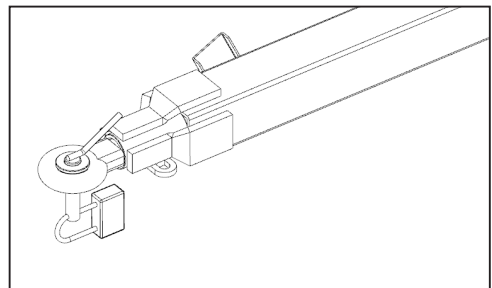

4 - Starting up

Coupling the driveshaft

Initial installation of the driveshaft may involve having to cut the axle to adapt it to the tractor to which it will be hitched. To hitch it for the first time, proceed as follows:

1. Attach the mistblower to the tractor in such a way that the distance between the PTO shaft and the mistblower pump is the shortest possible.
2. Stop the engine and remove the ignition key.
3. If the driveshaft needs to be shortened, pull the two parts of the shaft apart. Fit the two parts of the shaft, one to the tractor and the other to the mistblower crankshaft and measure out the length that needs to be removed. Mark the protection guards.



ATTENTION! The shafts must always have a minimum overlap of one third of their working length.

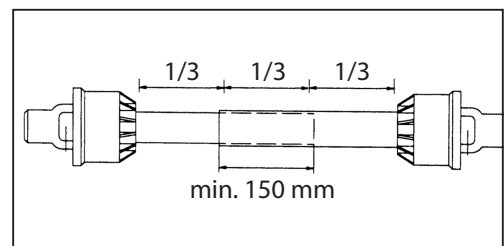
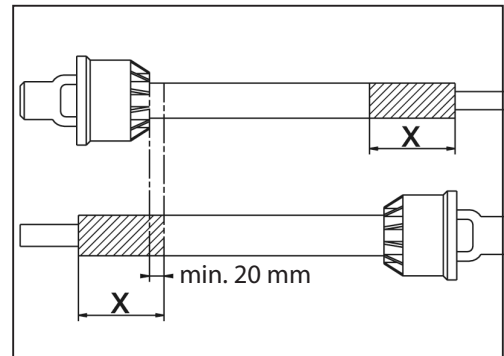

4. Cut both parts equally, using a saw. File the profiles afterwards to remove burrs.
5. Grease the profiles and reassemble male fitting and female fitting.
6. Fit the shaft to the tractor PTO and to the mistblower pump shaft.

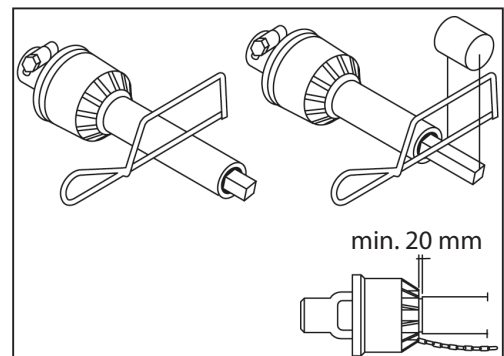

7. Place the input part towards the tractor. Fit the chains to prevent the protection guards from rotating with the shaft.

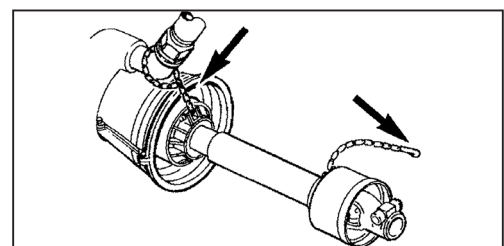

ATTENTION! To ensure long life of the driveshaft and prevent possible damage to the equipment, try to avoid working at angles of more than 15°.

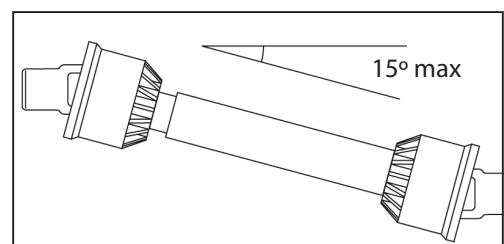

Hydraulic connections

General information

Make sure that the couplings are clean before fitting them!

After pressing the brake pedal and when the system is filled with oil, check the level of hydraulic oil in the tractor and refill if required.



DANGER! Testing the hydraulic system should be done with care. Air may have entered the system and cause sudden movements.



DANGER! Oil leakage: Do not use your hands under any circumstances to locate a leakage in any point in the hydraulic system. Due to the system's high pressure, the oil could penetrate the skin.

Tractor requirements

Hydraulic pressure of 180 Bar and a flow of 20 l/Min or 5 gal / min.

Below you'll find a table where the boom requirements are listed as 2D = 2 double acting hydraulic outlets 3D = double acting outlets etc.

Converted to 1 Double acting outlet.

All booms offer optionally a Small Joystick S3 or S5 to cover up to 5 double acting functions into just 1 double acting outlet.

Larger booms and sprayer with Combust circuit, are offered with V hydraulics, known as well as DAH – Direct activated Hydraulic.

Boom	Hydraulic rams	Operated by Optional or default
Liner		
Fix	N	
Start	N	
Start Fix	N	
Atlas		
Agile	3D	S3 or controlbox
Solid Agile GV	5D	S5 or controlbox
Solid GV	5D	S5 or controlbox
Boxer		
Agile	3D or 5D	S3 or S5 or controlbox
Solid	3D or 5D	S3 or S5 or controlbox
Cronos		
Rider H3	3D	S3 or combust
Rider H5	5D	S5 or combust
Varia H5	5D	S5 or combust
Varia GV H7	7D	Combust

4 - Starting up

Electrical connections

General information

If your equipment includes an electrical component, please note the following information to correctly connect the equipment and to prevent problems when working.

The voltage required by the electrical components is 12 V. Before connecting any component, make sure that the polarity is correct.

Red wire = 12 V (+ positive)

Black wire = (- negative)

This is the standards for the majority of modern tractors. If your tractor has another type of power supply connector, the supplied connector will need to be removed and adapted to the tractor connector.

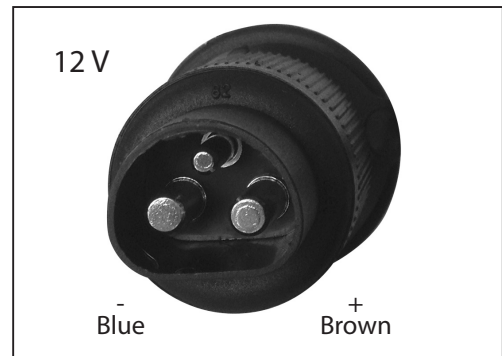

Standard control box

Bow with toggle switch.

Either 2 or four section

On off

Pressure regulation



Technical control box

Find a place in the tractor's cab where it is possible to fit the control box so you can operate it as comfortable as possible. The most recommended place is to the right of the driver's seat.

The control box must be properly attached to prevent it from being hit or from excessive vibrations.

The connector type is universal and it should be able to be connected to any tractor. Do not connect into coincidently wires in tractor cabin, as it will not secure stable power and current.

Minimum requirement: min 11V max 13 V Amp. Per SV section 2.5 Amp. Per CB section 0.75

As an emergency solution, remove the connector and splice the wires directly to the battery, remember to have fuse in-between.

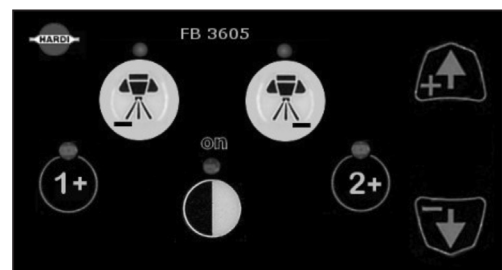

The control box must be properly attached to prevent it from being hit or excessive vibrations.

The connector type is universal and it should be able to be connected to any tractor.

As an emergency solution, remove the connector and splice the wires directly to the battery.



WARNING! Always remember: Red wire (+) Black wire (-)



DANGER! Always turn off any spray computer before you unplug the power supply and cable to the sprayer. Data transmission must stop, before power supply is stopped.

Rate controller

Rate controller DB 3610

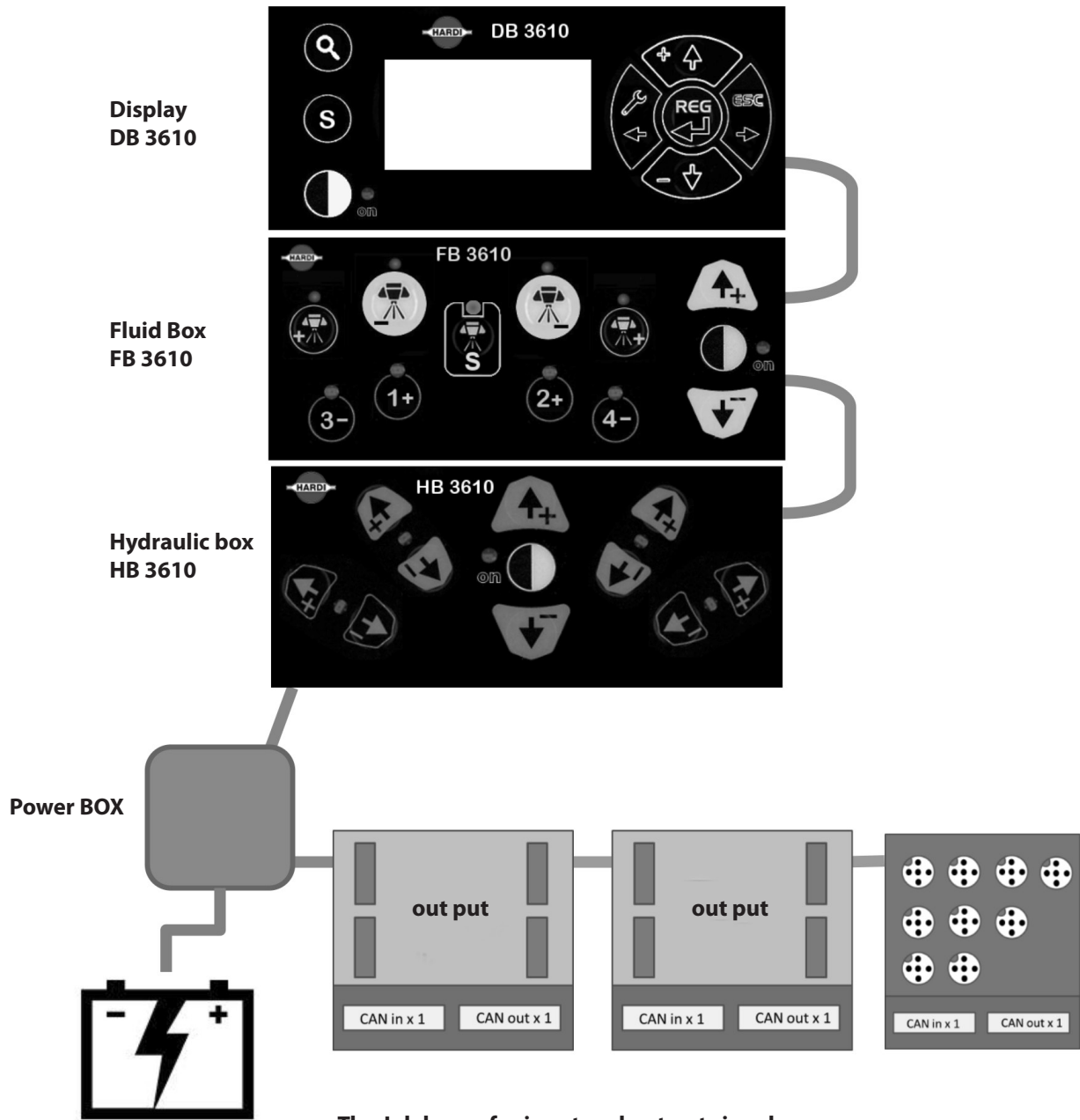

The Job boxes for input and out put signals

4 - Starting up

Rate controller DB 3620

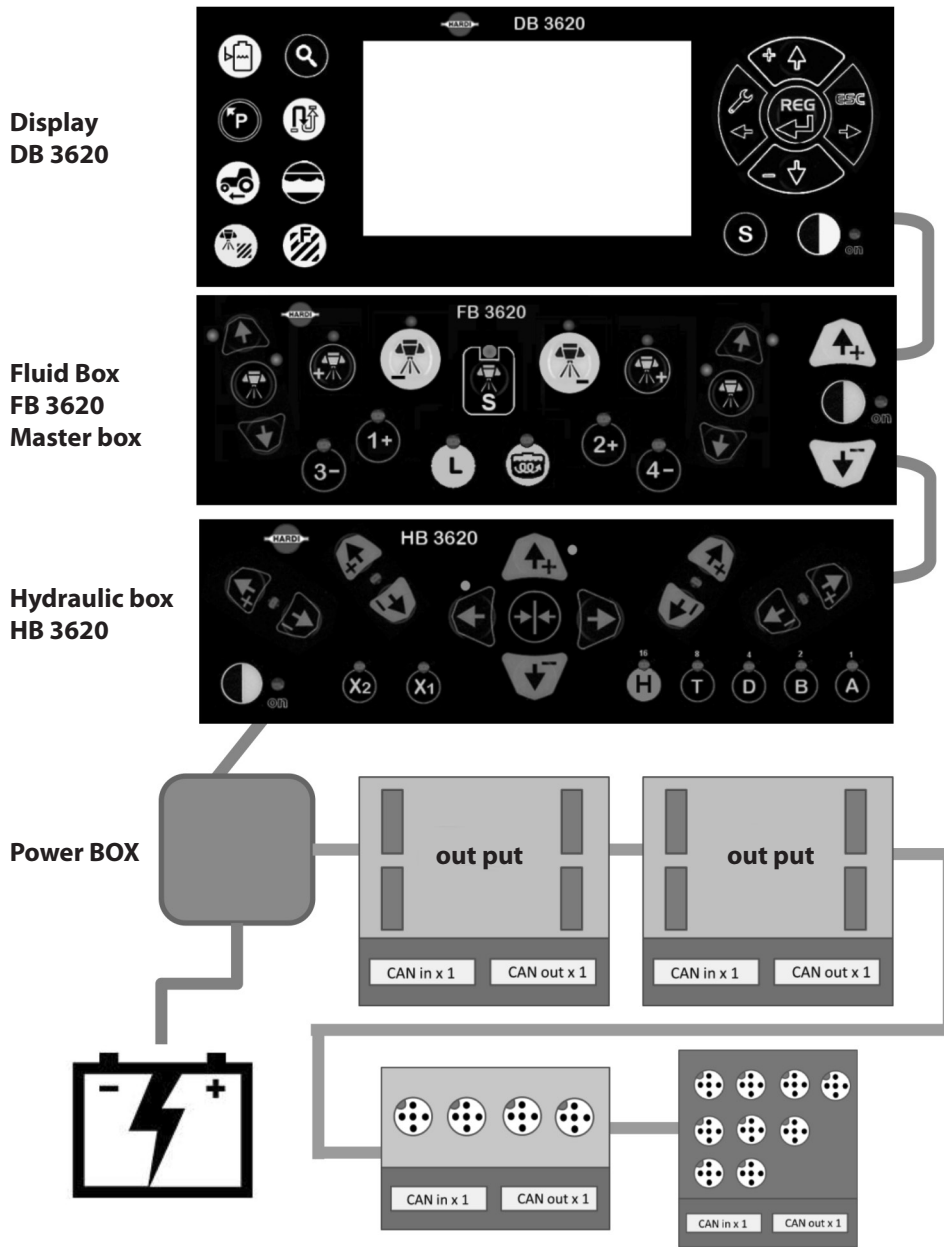

The Job boxes for input and out put signals

Fluid circuit

Suction filter

The mesh size of the standard filter is 50 meshes. 80 and 100 mesh filters are available and can be changed by opening the top lid of the filter. Check the O-ring before replacing the lid and replace it if it is damaged.



ATTENTION! For better sealing between the lid and the O-ring, coat the area between the joint and the lid with grease. This will make the O-rings seal and avoid suction of false air.

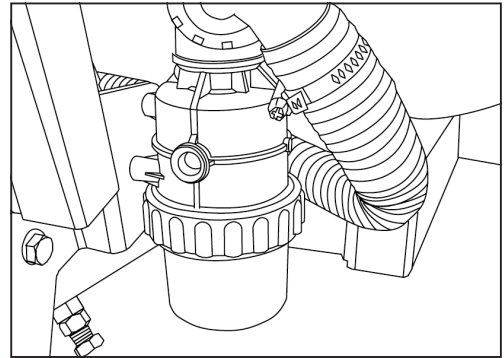

Pressure damper

The air pressure of the pulsation damper (321 pump) is factory-set at 2 bar to match spraying pressures between 3 and 15 bar.

When spraying with different pressures than this, you must change the pressure of the damper. Follow the list to adjust it to the correct pressure. This table is also engraved on the damper.

Spraying pressure bar	Pulsation damper air pressure bar
1.5 - 3	0 - 1
3 - 15	1 - 3
15 - 25	3 - 4

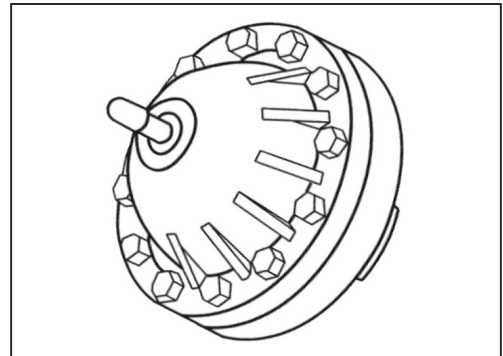

Diaphragm pump

Before starting to use the machine, make sure the diaphragm pump is well greased to prevent wear.

The pump is greased from factory, but should be greased again during bedding in and then every 50 hours.

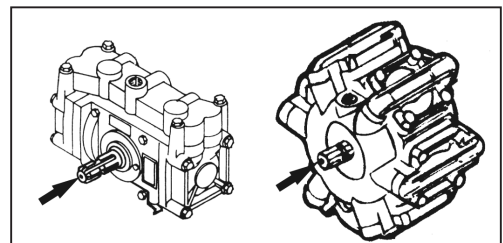

Piston pumps

It is advisable not to work at more than 540 r/min. Do not run the pump dry for more than 60 seconds.

Before starting check the oil level of the pump. It must be between the maximum and minimum marks (1) on the dipstick located on the upper part of the pump.

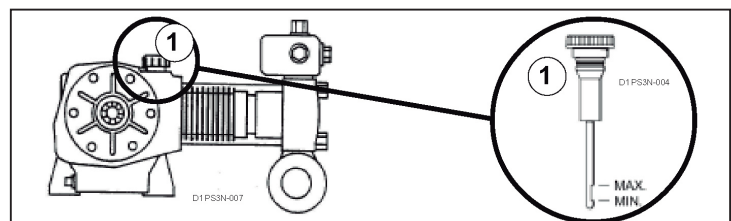

WARNING! Piston pumps need to be run in. When starting up take the following steps.

1. Start up the PTO at 540 r.p.m.
2. Raise the pressure to maximum and let it turn over for 5 minutes.
3. Halve the pressure and let it turn over for another 5 minutes.
4. Drop the pressure to 0 bar and let it turn over for another 5 mins.

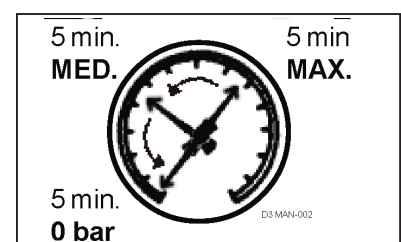

4 - Starting up

Deflectors



ATTENTION! Never access area or adjust deflector or any other part near the air kit, while tractor is started.

V deflector

Park the sprayer in the orchard, between 2 tree rows, adjusted it visually to point towards the tree top.

Tight up adjustment bolts, test with clean water. And verify target is well sprayed.

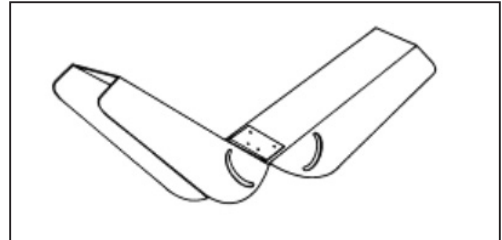

Top S or L

S is for the short version L the slightly higher version..

Parked between rows, orientate the adjustable air outlet towards the target, and test with clean water.

Top S adjust from 90° to 50°

Top L adjust from 110° to 70°

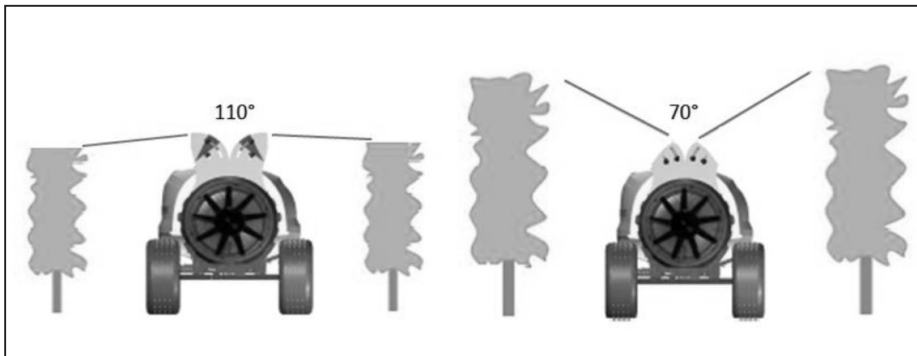

Adjustable bottom deflector

Allows directing the air upwards avoiding air turbulence on the ground and stems, as often used in e.g. plum orchards

Adjust it between rows, test with clean water.

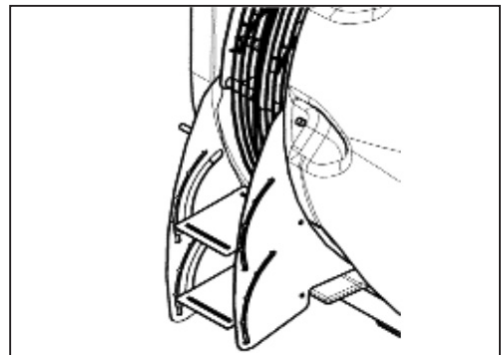

4 - Starting up

Adjustable bottom deflector

Allows directing the air upwards avoiding air turbulence on the ground and stems, as often used in e.g. plum orchards.

Adjust it between rows, test with clean water.

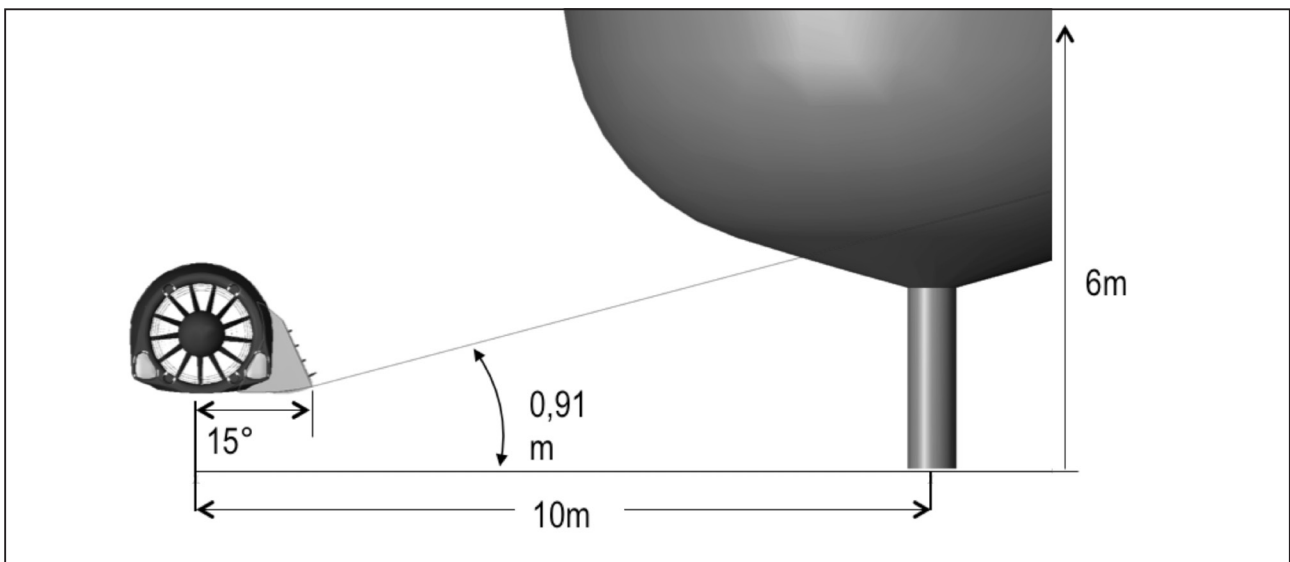
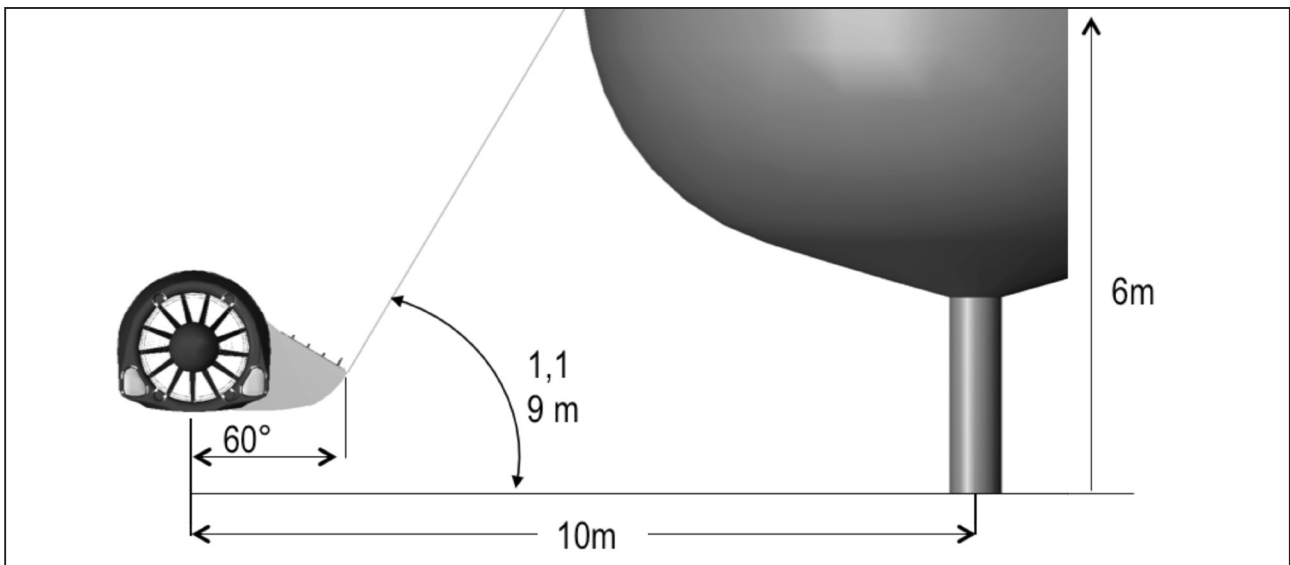
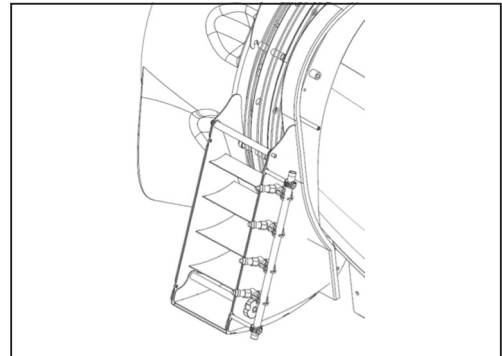

4 - Starting up

DUO P deflector

Fixed position of air outlet, nozzle holders placed in front of the air outlet, easy accessed for calibration.



DUO T and V deflector

Provides adjustability in the top of the deflector, to secure direction of air and spray mist towards the target. Loos the hand wheel, position the adjustable part in visual direction to the target, tighten up the hand wheel and test with clean water.

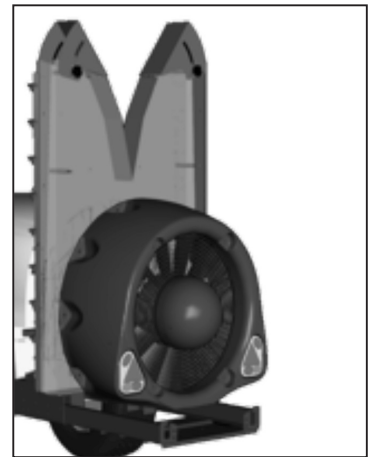

JET deflector

Provides adjustability in the top of the deflector as well as in the lower part.

Loosen the bolts of the adjustable bottom and top part, adjust it visually towards the target, tighten the bolts and test with clean water.



Booms

General information

All the booms have either minor or major options to adapt to the crop, all according to the technical level of the boom structure.



DANGER! When folding and unfolding the boom, be sure that nor people neither objects are in the operating area of the boom, and that the boom cannot touch any electrical conductors!

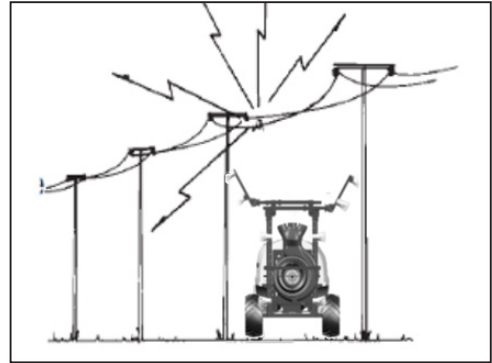

FIX

The FIX boom provides height and width adjustment of spraying device by loosening the bolts X and Y, positioning the spray device and tightening again.

Width adjustment from 7" to 40".

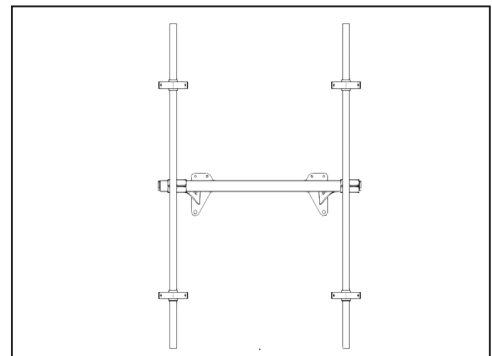

START

Provides telescopic width adjusted by loosening the bolt in pos, X. Once positioned, tighten the bolts again.

Width adjustment from 1.1 m to 1.8 m or 40" to 72"

The extreme part of the START boom can be equipped with 60° angling bracket, depending on the chosen spout set up. Remove pin bolt in pos. X and position it according to the crop.

The bracket as well allows to be turned 180° downwards by loosening bolts A.

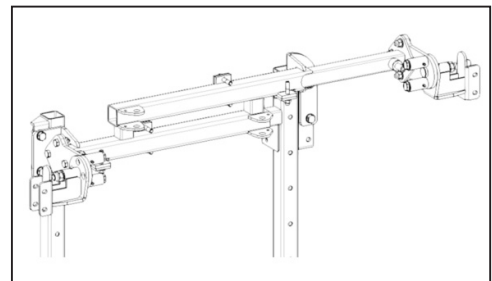

4 - Starting up

ATLAS AGILE

Boom wing width as ATLAS START, but combines with the FIX boom

ATLAS SOLID and ATLAS SOLID GV

The boom wing width adjusts from 13,7 ft. to 18ft or 4,2 m to 5,5 m

The centre section is the FIX system, consult description above.

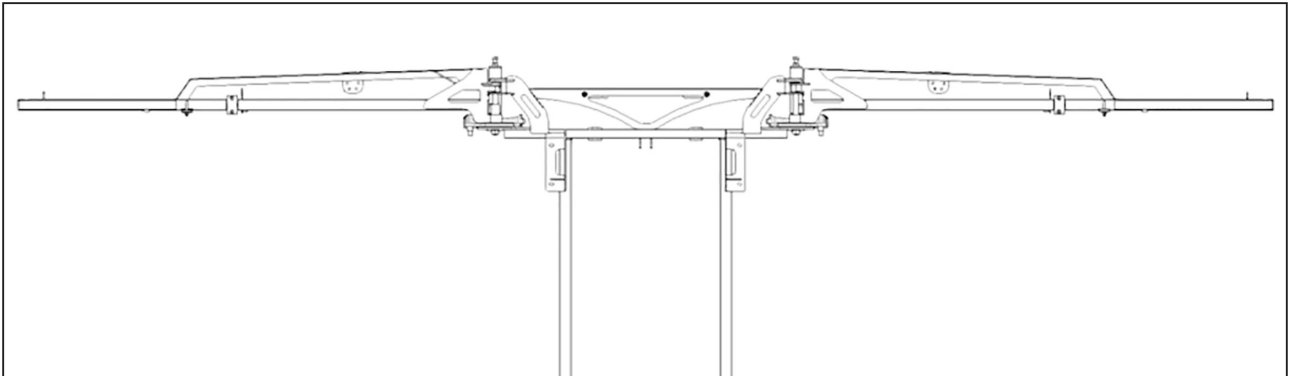

ATLAS SOLID and ATLAS SOLID GV

Same boom width as above, ATLAS SOLID, for adjustment of CONVERT boom part. Consult description above.

BOXER SOLID VERTICAL

Telescopes from 11.8ft to 15.7ft or 3,6m to 4,8m

Rear part FIX or CONVERT side adjustment, consult the respectively description above.

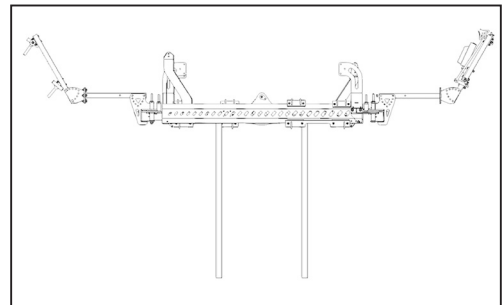

BOXER SOLID HORIZONTAL

Telescoping boom from 1,8 m to 5,4 m or 5.9ft. to 17.7ft.

Rear part FIX or CONVERT side adjustment, consult the respectively description above.

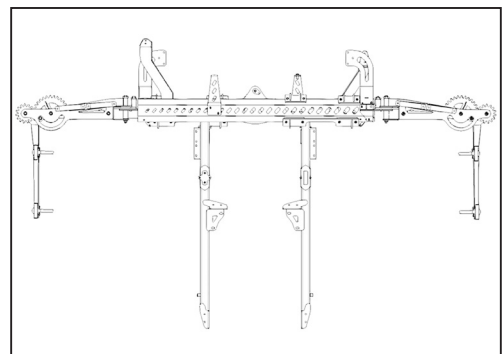

Adjustment of BOXER boom

Important to avoid destructive slack in the telescoping part, the slack must be adjusted.

Loosen counter bolt A tightened in bolt B , not to press into the telescoping boom part, but just hold it firmly and avoid slack. Tighten counter nut again.

Grease the part every 200 hours or annually.

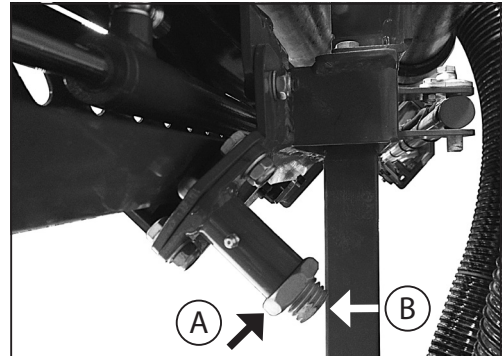

The indicated nylon friction parts must be kept clean, avoid sand and dust in them.

Replace when worn.

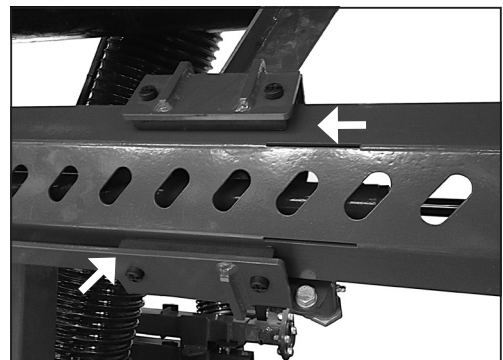

CRONOS BOOM

Exist as RIDER , GV or VARIA

RIDER

Has additionally to the boom wing rubber suspension, as well a trapeze suspension in the centre section.

Keep moveable parts free from dust and dirt. Grease weekly / every 50 hours.

The boom is 7.1 mts width. The spray device can easily be positioned on the boom with or on the centre section.

The boom's wing is equipped with a non-adjustable rubber suspension, to absorb the knocks from driving in the field. Be sure the rubber part is intact and that the bolts are well threaded.

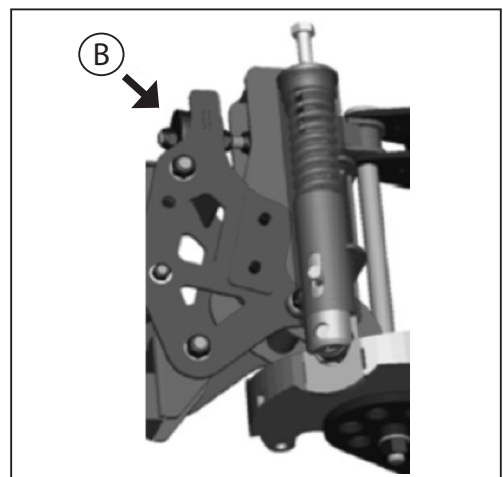
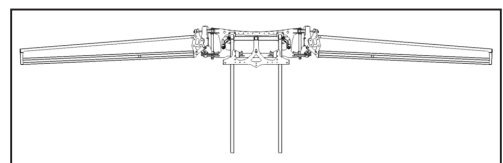

4 - Starting up

VARIA

The CRONOS VARIA provides hydraulic side adjustment, from the driver position.

The central part A is telescoping 0.65 m (26") to left and to the right side.

Secure the telescoping part is well lubricated, and all ways kept clean from sand and dust. The telescoping part has a guide in nylon friction pads; make sure they are in a proper condition.

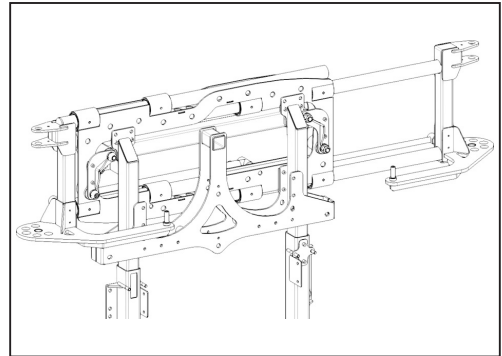

Once the VARIA system is telescoped out, it is not permitted to fold the boom, always roll up the VARIA system and then fold.

The drawing illustrates the VARIA system telescoped out to maximum position.

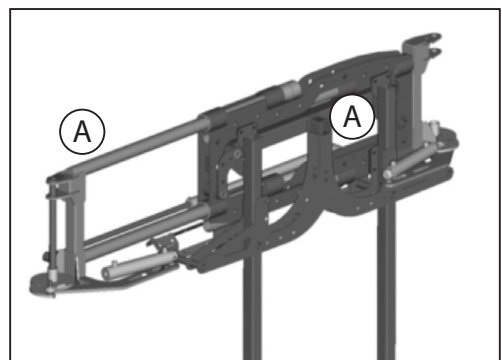

CRONOS GV

As in the RIDER and individual boom wing tilts.

Outer boom element can as well be positioned sideward, optionally with hydraulic piston.

General for all boom models

Break away clutch

All boom wings are equipped with brake away clutches, in vertical as well as in horizontal direction, according to boom specifications.

The clutch is adjusted according to boom weight and field conditions.

Soften and loose clutch. Loosen counter nut A, loosen bolt B. To tighten clutch to be harder; loosen nut A, tighten bolt B. Tension must never exceed of 15 Kg / 30 pounds, otherwise outer boom wing will open or activate the boom clutch.

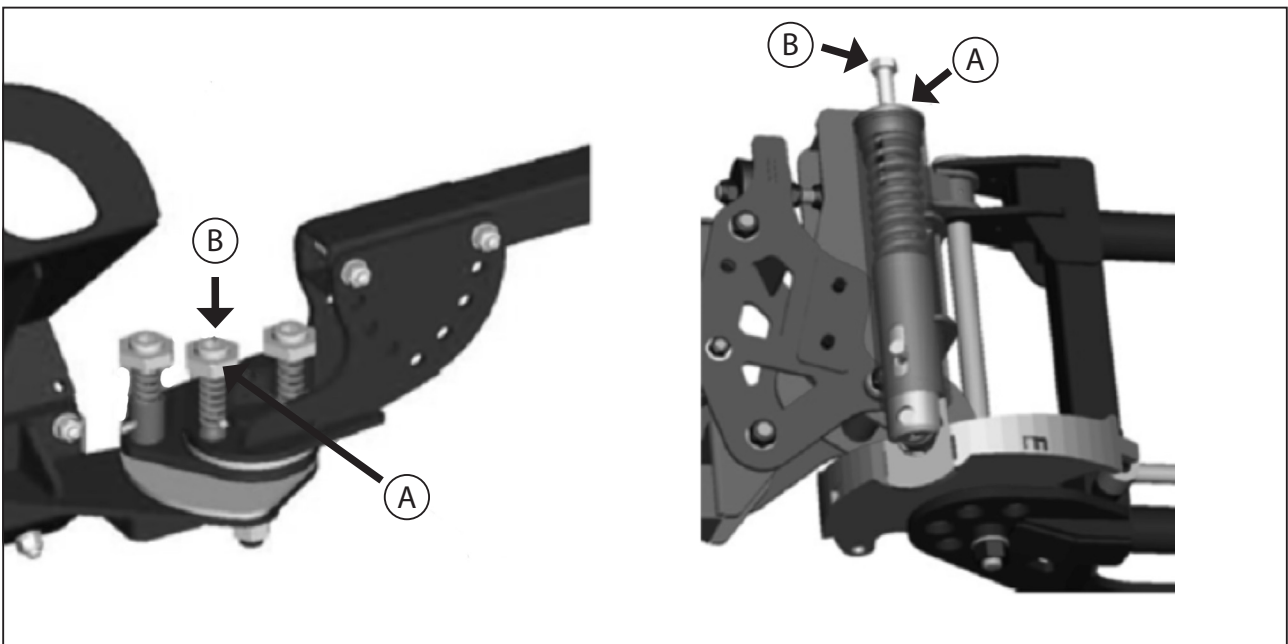

Adjustment of hydraulic fold

To achieve the correct folding position of the boom wing, the folding cylinder must be adjusted.

Undo the counter nut A, remove the cylinder eye B from the position, turn it either in or out accordingly to find the right position of the boom in transport as well as in working / spraying position.

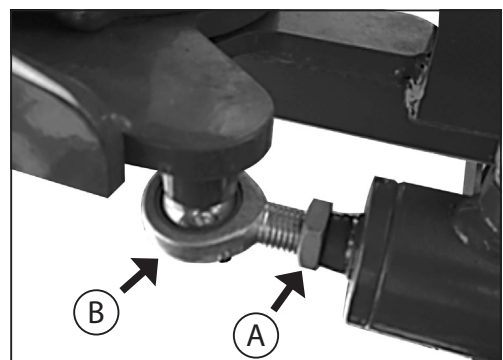

4 - Starting up

Transport bracket

The transport bracket secures the boom wing in transport. To position it, loosen the indicated bolts, adjust to the firm resting position of the boom, and tighten the bolts again.

Inspect weekly the transport bracket, and secure the nylon friction parts are intact.

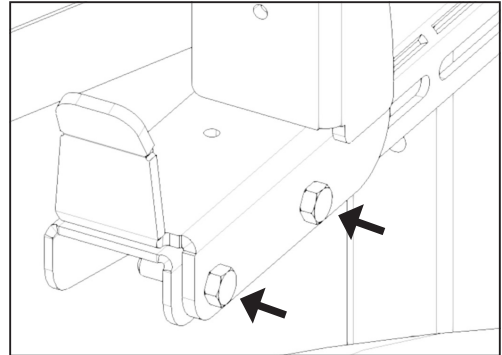

Adjustment of upright

The upright needs to be adjusted for slack between the male and female tubes.

Tighten on the two indicated nuts, just to make it press gently on the inner male tube, if it is too tight it will not be moveable, if it is too loose it will have destructive slack.

A nylon friction part is pressed towards the inner male tube; keep it clean from dust and sand. Replace the nylon friction part when worn.

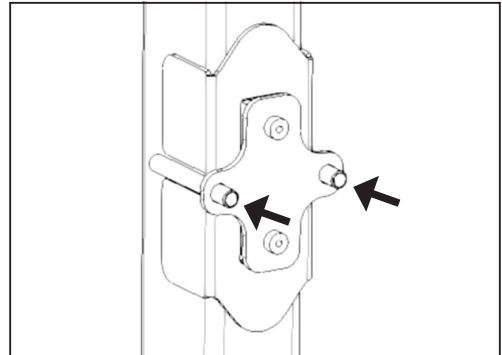

Adjustment of out spray device

The out spray device is easily adjusted

You can do it manually by loosening the indicated bolt A, moving it to the desired position, and tightening again the bolt.

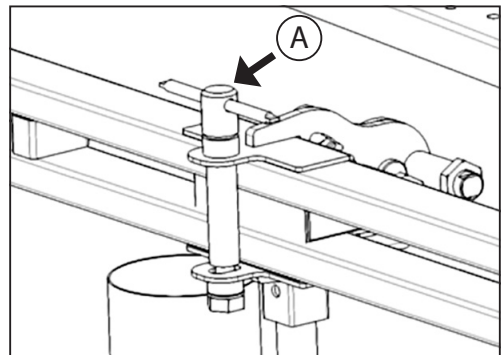

4 - Starting up

The hydraulic version

Make sure the indicated bolt B is not pressing hard on the sliding part, the black nylon roller must run freely in the rail.

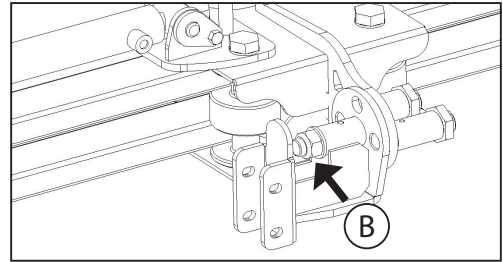

According to the spray device, the outer positioning is as show in the picture. To adjust to desired position, loosen the indicated bolt A, move the spray device to correct position and tighten the bolt again.

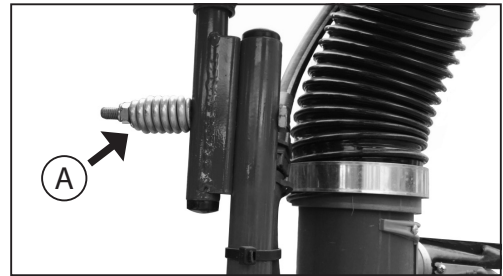

Adjustment of inner 4 spray device

The optional S bracket, as indicated by the arrow in the photo, can be mirrored 180°. Thereby the spray device is able to be positioned behind the sprayer.

Undo the 2X 4 bolts, turn the bracket 180° and fit all bolts again.

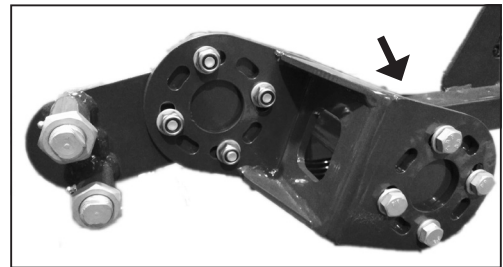

The Convert brackets provide a telescoping side adjustment, loosen the indicated bolts, slide the inner boom tube to desired position, and tighten again the bolts; just enough to let the nylon friction pads press and hold it in position.

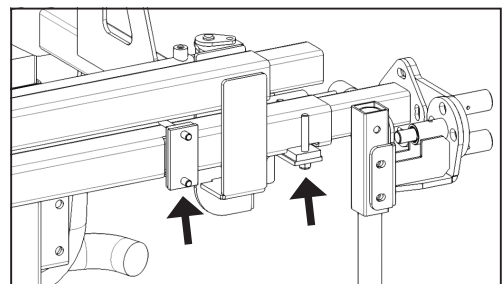

Hydraulic adjustment of the Convert brackets

Optionally the boom can be hydraulically adjusted from the tractor cabin.

In that case let the above indicated friction pads be just as loos as it allows the inner tube to slide in and out easily.

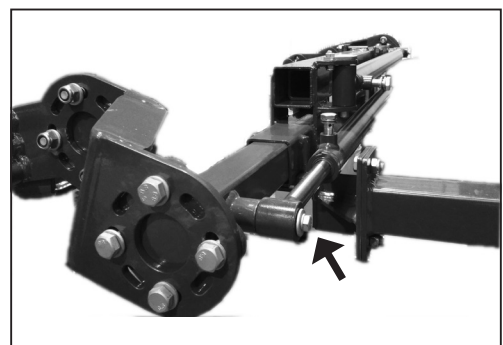

4 - Starting up

OPTIMUS spray spouts

The grey part, the air guide, allows multiple angle positions, to direct the air to the target.

Press gently the red wall side and set the desired angle.



The non drip valve closes at 0,4 bar and opens at 0,6 Bar.

Same valve has a tap, to close the liquid outlet, turn it clockwise to close, and opposite to open.

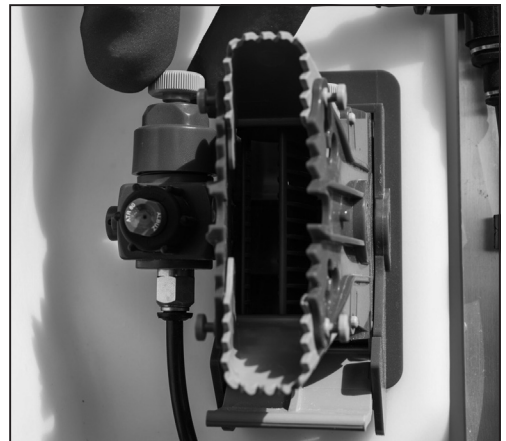

Close the air.

Loosen the bolt, turn the bolt side wise , and the internal wall blocks the outlet.

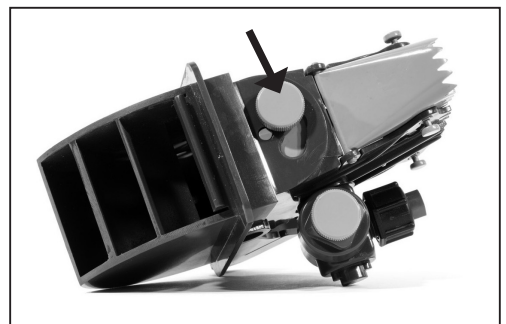

To remove the spout from the polyethylene body, flip down the grey pedal A, and the spout falls out.

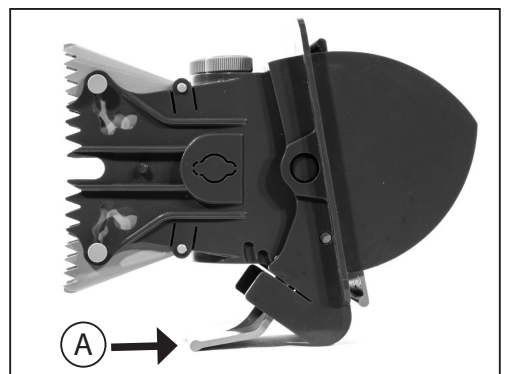

4 - Starting up

Cannons

On CANNON models, there are three different spout types. Model L is only fitted on variants with one turbine. It comprises 4 bi-jet holders with two nozzles each. In addition to the spout nozzles there are three adjustable nozzles outside the spout which allow treating the nearby crops also.

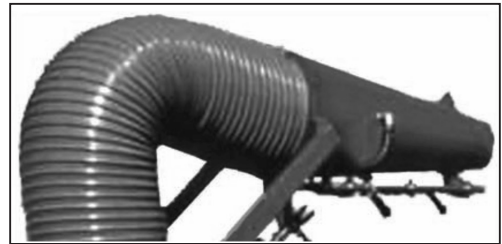

Model T is fitted on variants with two turbines. It has 7 bi-jet holders in a star-shaped pattern with three nozzles each. In addition to these nozzles, there are three adjustable nozzles outside the spout which allow treating the nearby crops also.



Model M is fitted on variants with two turbines. It comprises an outlet of 10 nozzles and there are two more with three nozzles each. You can adjust the direction in which the ends of the upper and lower spouts point.



Calibration

Enter www.hardi-international.com and download the Excel programme for calibration.

The working distance given is the total sprayed distance. If there are two rows of 1,8 then multiply by 2 that equals 3,6 m.

Check your speed.

See as well mistblower technique on www.hardi-international.com

In put		ATR	l/min
Work- Row dist. m	3,6	32	0,24
Velocity km/h	5,0		0,33
Pressure Bar	4,0		0,43
Read out			0,66
Dose rate l/ha.	259		0,88
Litres / min.	7,76		1,25
			1,34
			1,58
			1,79
			2,19

4 - Starting up

Enter field data in the green area

Enter the total nozzle combination of the machine

In put		ATR	l/min
Total sprayed distance in m.	3,5	W	0,27
Velocity km/h	4,7	L	0,37
Pressure Bar	5,0	B	0,48
Read out		Y	8
Dose rate l/ha.	501	O	8
Litres / min.	13,74	R	1,39
		G	1,50
		G	1,77
		B	2,00
		B	2,45



← Flow per nozzle at set pressure (1 nozzle).

Check nozzle out put on the sprayer every 150 hours.

In put		ISO	l/min
Total sprayed distance in m.	3,0	P	0,30
Velocity km/h	5,0	O	0,40
Pressure Bar	3,0	G	0,60
Read out		Y	0,80
Dose rate l/ha.	576	L	1,00
Litres / min.	14,40	B	1,20
		R	1,60
		B	2,00
		G	2,40
		X	3,20
		B	4,00



Work distance is the total width sprayed.

A sprayer covering 2 or 3 row or a CANNON spraying 20 meters.

Check the speed, do not trust the table read out from the tractor.



$$\frac{\text{metres driven} \times 3.6}{\text{Seconds it takes}} = \text{Km/h}$$



Manometer pressure must be checked with another manometer yearly, or if it had been bumped.

Colour of the nozzle

ISO	ATR 1299	Ceramic disc 1099	TRV
-----	----------	-------------------	-----

Make sure you are on the right page, ISO Nozzle or ATR nozzle. Pneumatic sprayers use Ceramic disc.

5 - Operation

Blower unit

Safety information

The fan must not be in operation when driving on public roads. The nozzle opening function should never be used on public roads. Any failures could cause injury to people and animals or damage the crops.

In the event that the machine needs to be in operation (agitation) while driving along public roads until reaching the field, make sure that the gearbox speed selector is switched to neutral position.



DANGER! If any unusual noise or excessive vibration in the air kit is detected then stop the equipment immediately and have it serviced by an authorised HARDI technician.

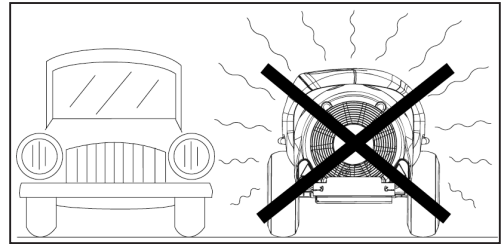

Selecting the gear

A low or high gear can be selected using the specially designed lever.

On the rear, left-hand side of the machine the selection lever is accessed between the tank and fan (A).

To change the speed, pull the lever outwards (A) and then move it up or down as required. Lock the lever in the selected position (at the lid).

Bottom position: 1st gear or low speed (1).

Top position: 2nd gear or high speed (2).

Centre position: Neutral (0).

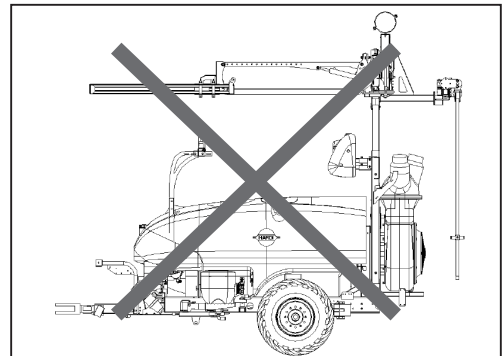
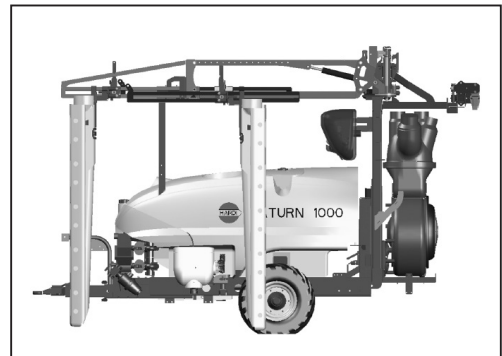
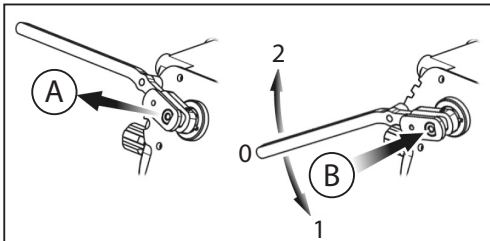

ATTENTION! Do never drive and fold booms at same time. Never manoeuvre the sprayer unless the boom is 100% unfolded, otherwise the upright will be damaged.

When the boom is folded, it must rest on transport bracket before driving.

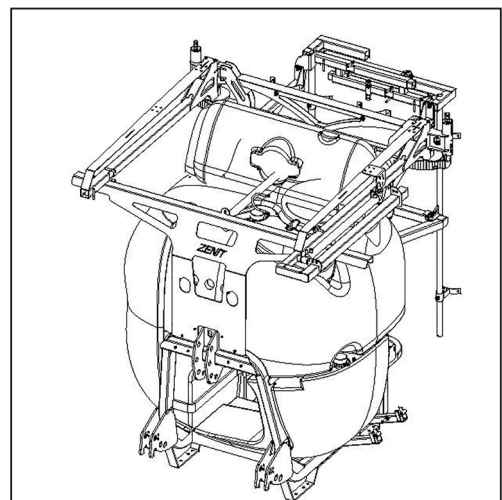

5 - Operation

While moving the Sprayer

The booms must be 100% unfolded or resting in the transport bracket.

The boom must unfold, and stay firmly, stiff, not wobbly. If the boom is not held firmly unfolded during spraying, it will auto damage the structure due to the movements caused from lack of firm position.

See maintenance and starting up (Adjustment of hydraulic fold).

Secure folding cylinder is correctly adjusted, and eventually the stop positions / stop bolts, are adjusted correctly in order to secure that the boom stays rigid and firm while working. To reinforce, eventually a trapeze or pendulum suspension can be activated, but it can't be rigid, it must be movable and floating.

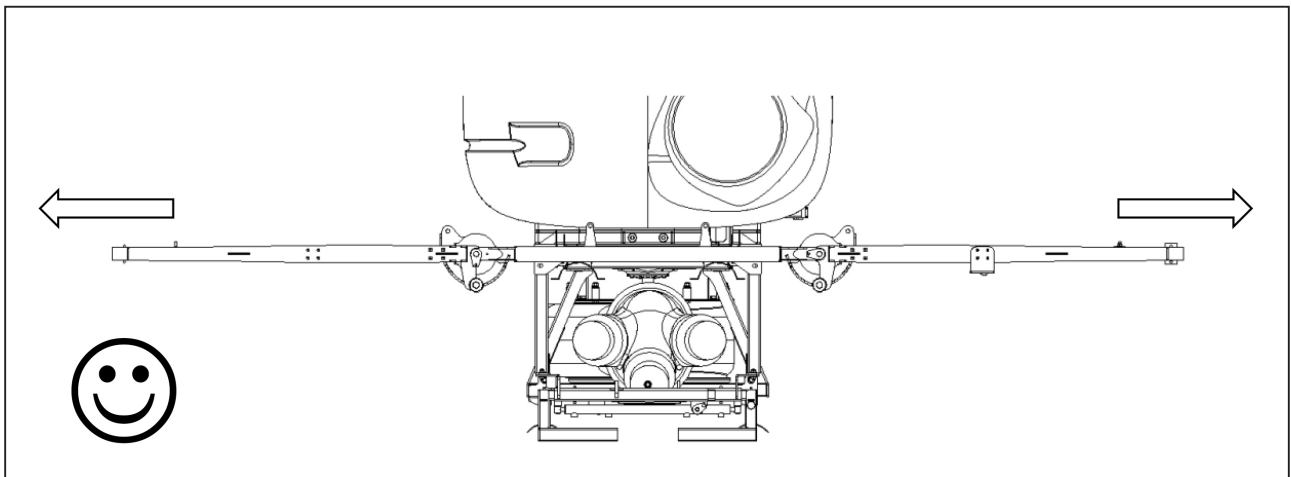
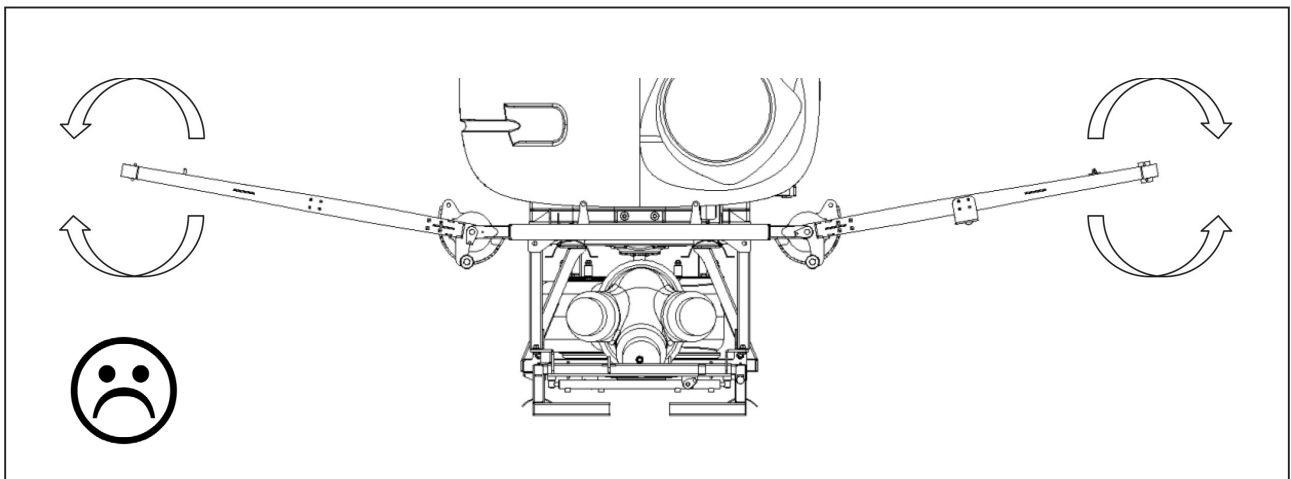

5 - Operation

Adjusting the fan A6820 and SF65/SF85 and XF90

The angle of the fan blades can be adjusted to 4 positions. The factory setting is pos. 3 (40°). Decreasing the angle of the blades (minimum angle, pos. 1 (30°)), reduces the air flow and power consumption. Increasing the angle (maximum angle, pos. 4 (45°)), will increase the air flow and power consumption. It allows the mistblower to be adapted to the different spray jobs and tractor sizes.

To change the angle of the fan blades you should follow these steps:

1. Loosen the Allen screws without taking them out completely.
2. Loosen the Allen screws whilst holding the nut at the back of the fan.
3. With both hands on opposite blades, turn them to the desired position between 1 and 4. All the blades should turn at the same time.
4. Finally, check that all the blades are in the correct position.
5. Tighten all the screws.

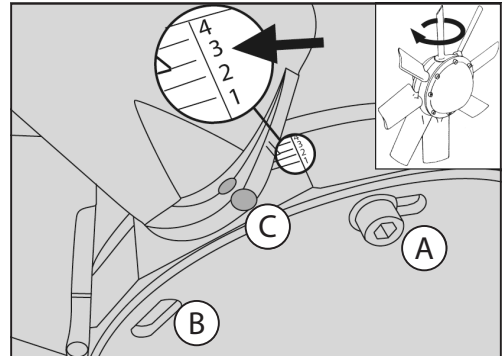

IMPORTANT The fan must be calibrated correctly after changing the pitch setting.

For technical details ask your dealer or the manufacturer.

Single side blinds (Optional)

The air stream can be blocked to one side to prevent spray drift towards sensitive areas.

This is used when one section valve is shut during spraying along orchard edges, streams, open waters or other sensitive areas where spray drift must be kept away.

Loosen the nuts, slide the blind over the air outlet and tighten the nuts again.



ATTENTION! Only slide the blind of one side at the time. Never close both sides at the same time!

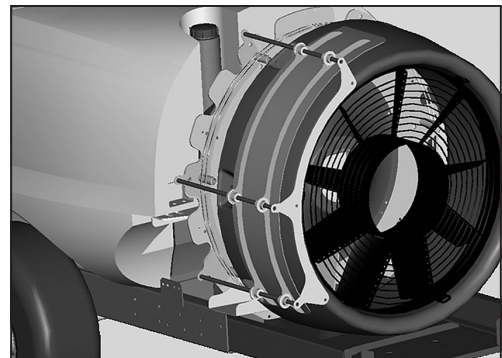

5 - Operation

Fluid circuit

Filling/washing location requirements

When filling the sprayer with chemicals and water it is important to avoid spot contamination by spray chemicals in order to protect the subsoil water resources.

- A. If the mistblower is always filled at the same place, a special filling/washing location should be established. This should have a hard, liquid-impenetrable surface (e.g. concrete) securing against seepage and edges securing against run-off to the surrounding areas. The place should be drained to an adequate receptacle (e.g. slurry tank or similar).

Any spillage or washings should be retained and diluted in order to be distributed on a larger area to ensure minimal environmental impact and avoid build-up of larger chemical concentrations at one spot.

If no other requirements of distances exist, the following general recommendation of distance could be used. Not closer than:

- 1) 50 metres from public water supplies for drinking purposes,
 - 2) 25 metres from non-public water supplies for drinking purposes, treatment sumps and cesspools of drainage systems, and
 - 3) 50 metres from surface water (watercourses, lakes and coastal waters) and from nature reserves.
- B. Alternatively the sprayer can be filled in the field where the spraying is to take place. If so, choose a different location for each refilling.

If no other requirements of distances exist, the filling should not be established closer than:

- 1) 300 metres from public or non-public water supplies for drinking purposes and
- 2) 50 metres from surface water (watercourses, lakes and coastal waters), treatment sumps, cesspools of drainage systems, and nature reserves.



ATTENTION! Legislation and requirements vary from country to country. Always follow local legislation in force at any time.



NOTE! It is the responsibility of the sprayer owner/operator to comply with all relevant legislation. HARDI cannot undertake any responsibilities for incorrect operation and use.

Filling with water

The tank should be filled to a third of its capacity with clean water before adding the chemical product. Always follow the instructions given on the product label!.



WARNING! If spray liquid is left in the tank, for safety reasons all valves must be shut.

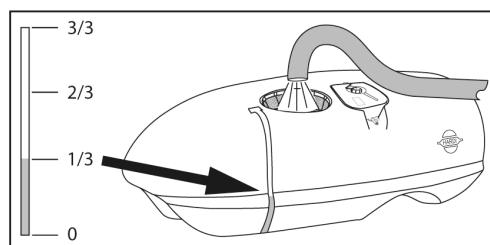

5 - Operation

Filling through tank lid

The tank is filled with water through the filling hole by removing the lid located on the top of the tank. The water used should be as clean as possible to obtain best results.

Fill the tank using the filter to prevent impurities from entering the tank. For greater filling capacity, an overhead tank can be used.



DANGER! Do not place the filling hose inside the tank. Keep it out of the tank at all times and only point it towards the filling hole. If the pressure hose was placed inside the tank and there was a drop in water supply pressure, the chemical product could be syphoned back and contaminate the water supply lines, plant and well.

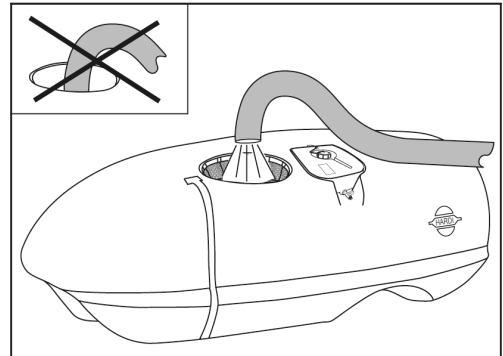

ATTENTION! The water supply line should be provided with a check valve as additional safety precaution. Follow local legislation in force at any time.



ATTENTION! The water supply should be provided with a meter to avoid spillage by over-filling. Follow local legislation in force at any time.

Filling the rinsing tank

The rinsing tank is integrated with the main tank.

Capacity: 90 litres for 1000 and 1500 litres main tanks, and 130 litres for 2000 and 3000 litres main tanks.

The illustration shows the location of the rinse tank.



ATTENTION! fill rinsing tank with clean water! To avoid algae developing in the rinsing tank always drain the rinsing tank if the sprayer is not in use for a long period of time.

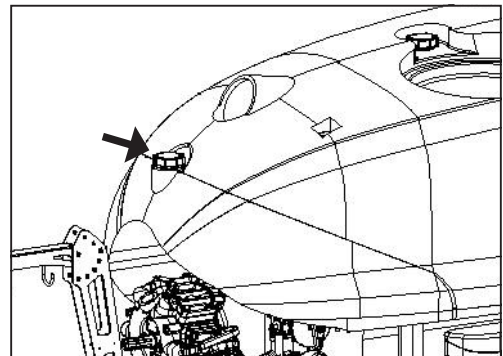

Rinsing nozzle

This is located inside the main tank. When the nozzle is engaged it rotates fast and sprays clean water in all directions.

If the machine is fitted with a rinsing system, there is one rinsing nozzle in 1,000-litre tanks, and two rinsing nozzles 1,500, 2,000 and 3000 litre tanks.

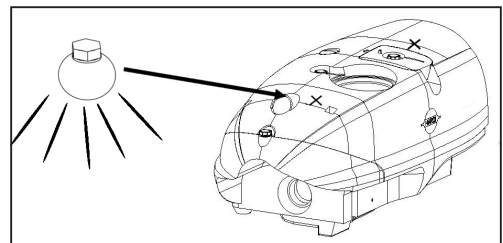

5 - Operation

Filling the clean water tank

The clean water tank is located at the front and integrated in the main tank design. It is used for washing hands, gloves and cleaning clogged nozzles, etc.



WARNING! Although this tank is completely separate from the main tank and should only be filled with clean water, this does not mean that the water is suitable for drinking.

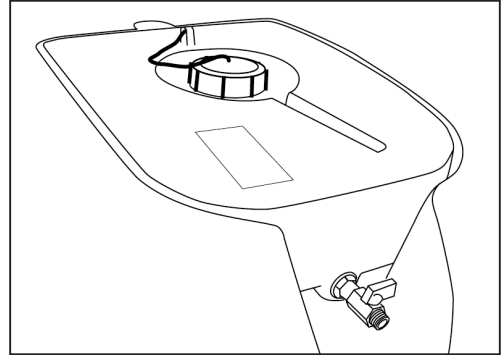

Drain valve

The valve for safe draining is located on the underneath of the tank. To access it, you must crouch on the left side of the equipment, where the jockey wheel is attached to the chassis when the equipment is hitched to the tractor.

To empty the tank, pull the handle towards the valve. To fill the tank again, pull the valve handle toward the front of the equipment and it will close.



WARNING! When opening the valve, take care to ensure that the liquid does not spill over your hands or feet.

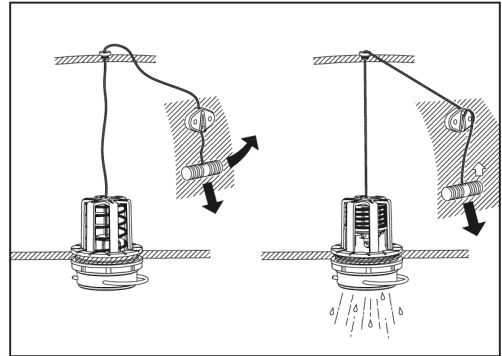

To empty the residual liquid in a special tank or container for storage, the quick release A of the drain valve can be adapted to connect a hose with the fitting B so that liquid can be emptied safely.

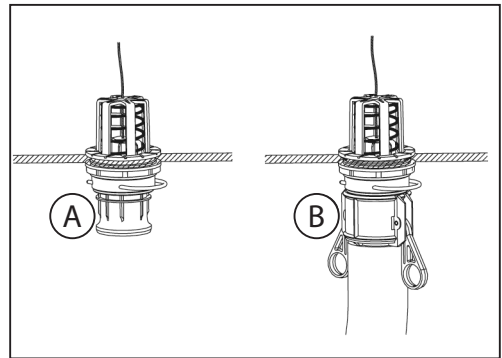

Manifold system

A & C is spraying position

B & C is TurboFiller position

D & E is Rinsing position

F is step less agitation. 3 is Max , 0 is closed

G is 15 bar safety valve; it is important to open it once in a while, especially under cleaning process, to avoid chemical residues in the tubes connected.

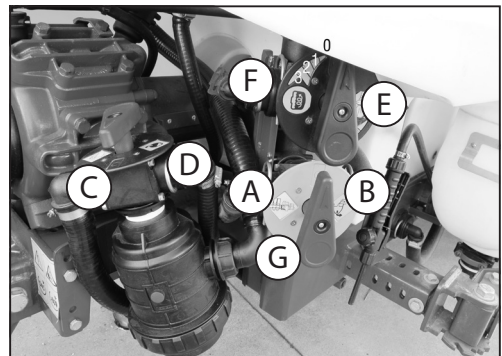

Manifold system MERCURY

MANIFOLD valves and pressure distributor

These are located at the front of the mistblower.

It consists of two manual three-way valves that allow different parts of the fluid circuit to be put into operation.

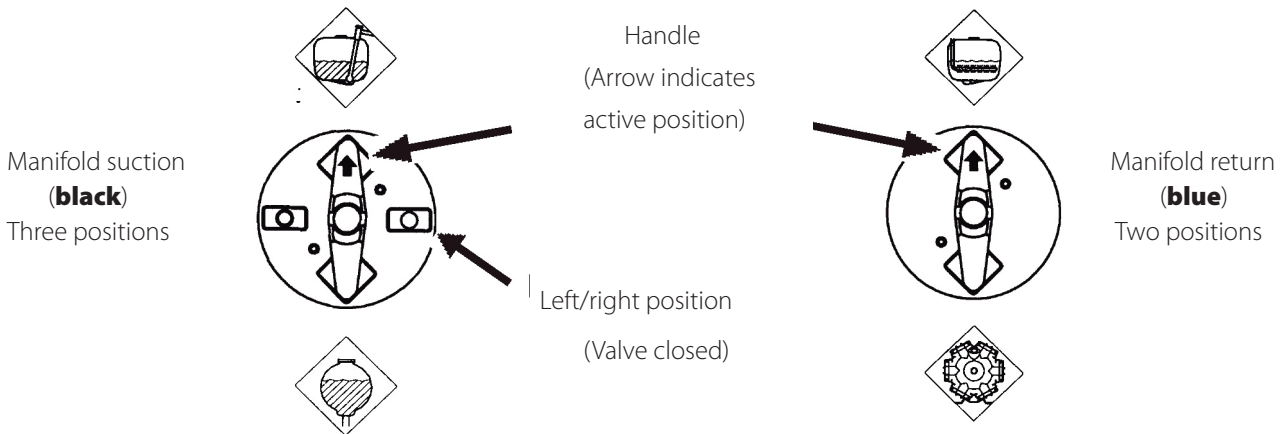

On the pressure distributor there are three taps (depending on the model), that send a pressure flow towards three different functions.

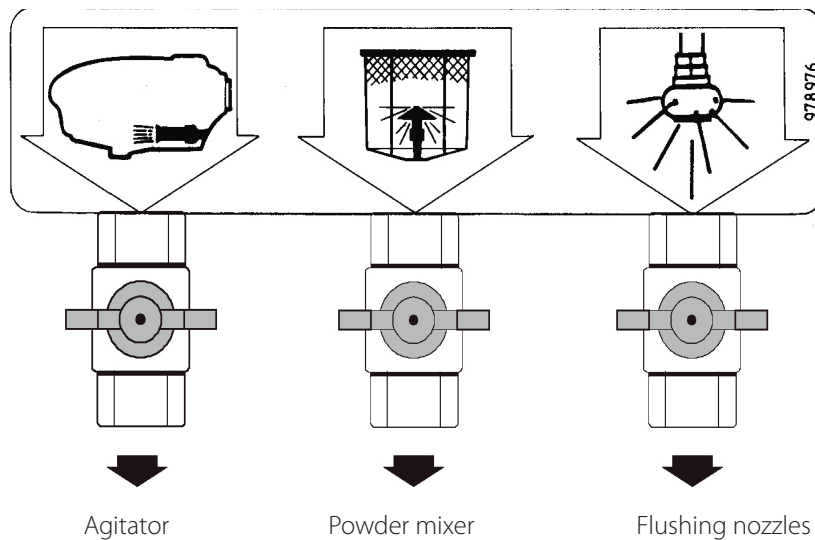

Operating instructions



The black suction valve has three positions. Two of the positions are for the optional equipment and the other, signalled by indicates that the valve is closed. The blue return valve has only two positions. The arrow on the handle points towards the chosen position.

Black suction valve



Turn the handle so that the arrow points towards the chosen option. The options that can be selected with this valve are the main tank or the clean water tank .

5 - Operation









Blue return valve

In the position , the liquid returns to the main tank through the agitator during the normal working operation. In order to empty the tank completely, turn the handle towards the symbol so  that the liquid is directed to the suction side of the pump.

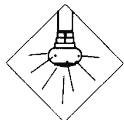
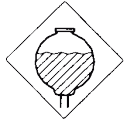
Blue return valve

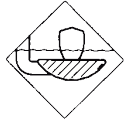
Turn the tap  on to send pressure to the agitator. By turning on the tap  you can operate the powder mixer, which will clean any product residues from the lid filter. By turning on the tap  you can clean the inside of the tank using the tank flushing nozzles.

Meaning of the graphic symbols

	Main tank		Pump return		Tank flushing nozzles
	Clean water tank		Pressure agitator		Filling device
	Return agitator		Powder mixer		Operating unit

Position of the handles during normal working operation

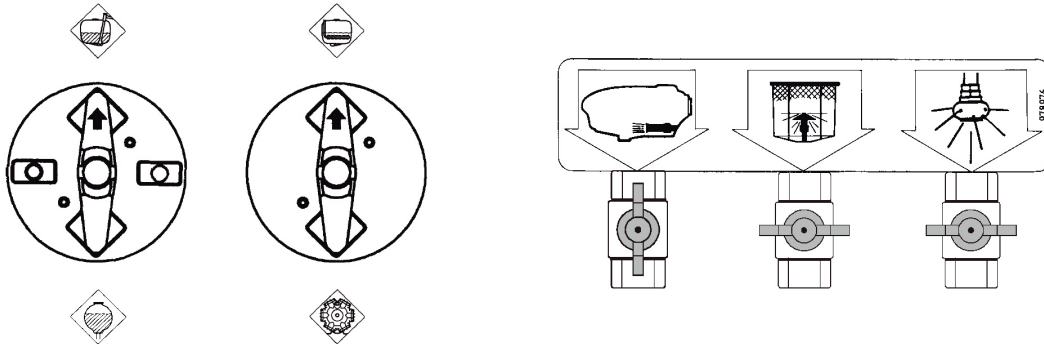

Position of the handles during machine cleaning operation

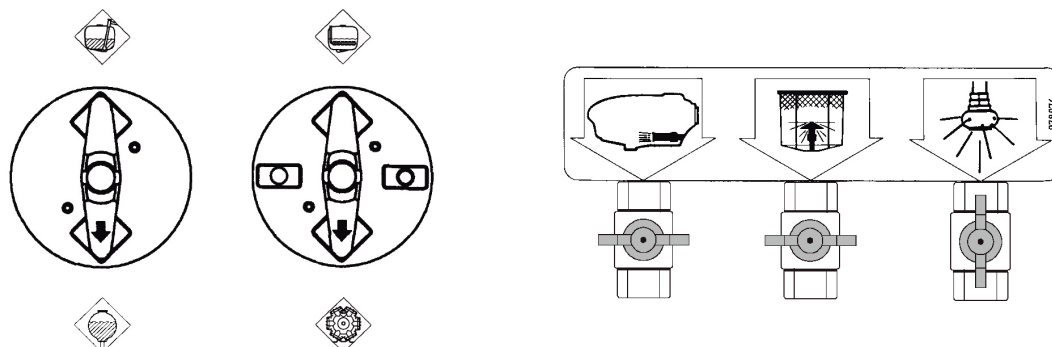

Suction Filter

This is located on the bottom left-hand side of the equipment and is easy to access. To clean the filter you should do as follows:

1. Close the three-way valve.
2. Shut the valve of the filter (A) before dismantling the filter.
3. Undo the filter housing (B) to access the filter screen.
4. Clean the filter (C) and assemble in reverse order.

The filter should be cleaned after each spray job while remaining spray liquid is still agitated. This will prevent operational problems caused by sediments.

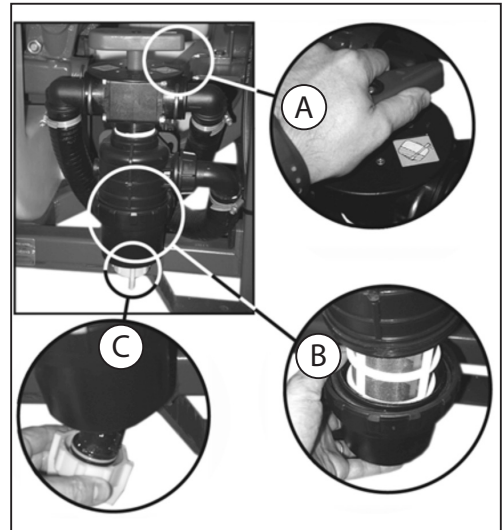

Filling liquid chemicals with HARDI TurboFiller (optional)

1. Fill the main tank at least 1/3 with water (unless something different is stated on the chemical container label).
2. Turn the Manifold valve towards TurboFiller.
3. Set the fan gear lever to neutral position, engage the pump and set P.T.O. at 540 r/min.
4. Open TurboFiller lid. Measure the correct quantity of chemical and fill in the hopper.
5. Engage the hopper transfer device by opening the TurboFiller suction valve so the chemical is being transferred to the main tank.

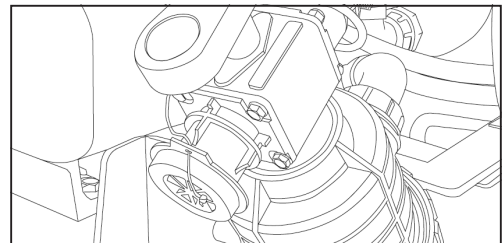
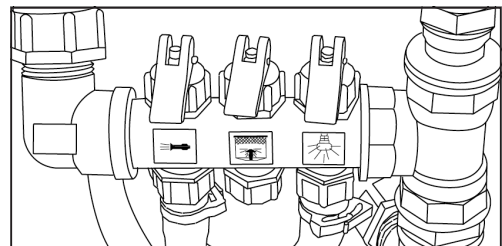

6. Engage the flushing device to flush the hopper. If powder chemicals are filled the flushing device must be open before pouring the powder into the hopper.

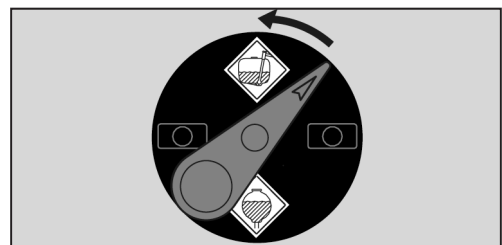

7. If the chemical container is empty, it can be rinsed by the Chemical Container Cleaning device. Place the container over the multi-hole nozzle and push the upper lever to the left of the TurboFiller.

8. Close TurboFiller suction valve when the hopper has been rinsed.
9. Close the TurboFiller lid.
10. Disconnect the pressure to the TurboFiller, and keep agitation activated to ensure homogeneous concentration.

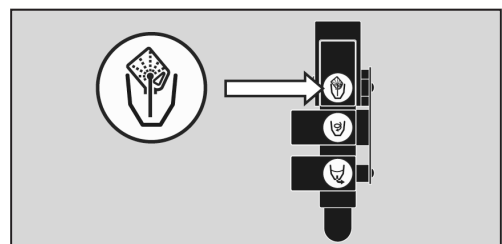

11. Engage the fan gearbox before spraying.

5 - Operation



DANGER! Always wear face shield and other appropriate personal safety equipment when filling chemicals.



ATTENTION! The scale in the hopper can only be used if the sprayer is parked on level ground! It is recommended to use a measuring jug for best accuracy.



DANGER! In order to avoid spray liquid hitting the operator, do not press lever unless the multi-hole nozzle is covered by a container as spray liquid may otherwise hit the operator.



ATTENTION! The rinsing device uses spray liquid to rinse containers for concentrated chemicals. Always rinse the chemical containers with clean water several times until they are clean before disposal.



ATTENTION! The hopper rinsing device is using spray liquid for rinsing the hopper of concentrated chemicals! Cleaning the TurboFiller must always be done when the spray job is ended and together with the entire sprayer. A cleaning after the last filling and before spraying the last tankful does not ensure a clean TurboFiller!

TurboFiller rinsing

Rinsing the TurboFiller and chemical containers is done in the following two ways:

When TurboFiller lid is open

For cleaning empty containers: put container over the rotating flushing nozzle in the middle of the TurboFiller so that the nozzle is inside the container. Press the Chemical Container Cleaning lever and the TurboFiller suction valve at the same time to activate the flushing nozzle in the middle of the TurboFiller and empty out the TurboFiller rinsing liquid.

When TurboFiller lid is closed

Use the Chemical Container Cleaning lever to rinse the hopper after filling of chemicals has ended. Press the Chemical Container Cleaning lever and the TurboFiller suction valve at the same time to activate the flushing nozzle in the middle of the TurboFiller and empty out the TurboFiller rinsing liquid. Do this 3 times and after the last flushing open the lid to inspect if the TurboFiller is empty. If not, close the lid again and press the TurboFiller suction valve until the TurboFiller is empty.



ATTENTION! The TurboFiller needs to be cleaned thoroughly after finishing spraying again to be sure it is clean before spraying other crops that may be sensitive to the chemicals just used. See section Cleaning for details.

5 - Operation

Pressure filters

Pressure filters will catch any remaining impurities and prevent nozzles clogging. To avoid blockage of those filters it is very important to check them regularly and clean them after each spray job to avoid chemical residues to deposit and block



WARNING! Wear appropriate personal protection when checking pressure filters.. As a minimum gloves and face shield.

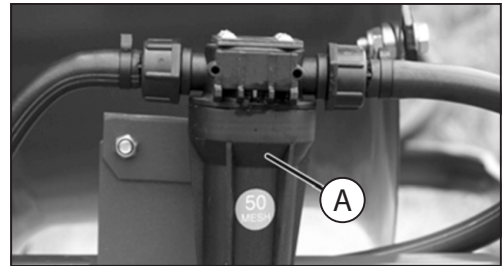

Agitation

The dual-nozzle agitation system injects the chemical product at high pressure from the pump inside the tank creating a turbulence that mixes the product with the water to a uniform liquid.

The standard agitation has 2 mm ventury nozzles. The ventury nozzle (B) allows an efficient agitation of the main tank content.

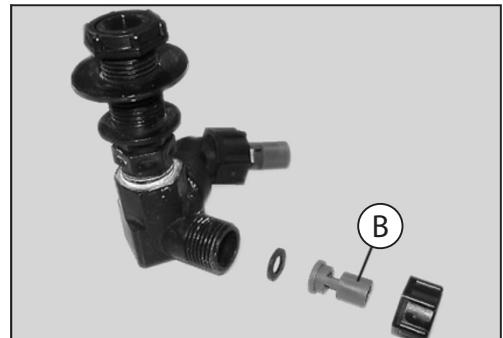

Clean water tank

The clean water tank is located at the top and integrated in the main tank design. It is used for washing hands, gloves and cleaning clogged nozzles, etc.

Unscrew the cap (A) to fill the tank. Open the tap (B) for clean water.



WARNING! Although this tank is completely separate from the main tank and should only be filled with clean water, the water is NOT suitable for drinking!

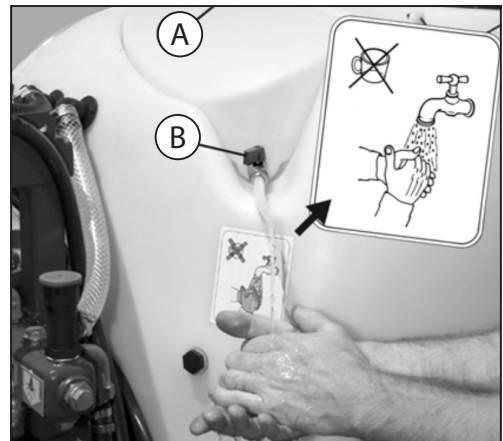

Powder mixer

This mixer will flush and dissolve powder chemicals through the tank strainer, eliminate lumpy spray liquid and improve mixing.



ATTENTION! After use, the powder mixer should be switched off, as it uses a lot of flow.

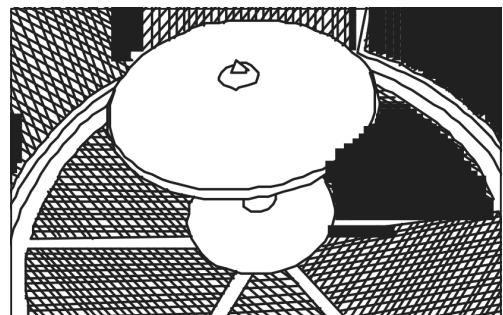

5 - Operation

Filling through tank lid

The tank is filled with water through the filling hole by removing the lid located on the top of the tank. The water used should be as clean as possible to obtain best results.

Fill the tank using the filter to prevent impurities from entering the tank. For greater filling capacity, an overhead tank can be used.



DANGER! Do not place the filling hose inside the tank. Keep it

out of the tank at all times and only point it towards the filling hole. If the pressure hose were placed inside the tank and there was a drop in water supply pressure, the chemical product could be syphoned back and contaminate the water supply lines, plant and well.



ATTENTION! The water supply line should be provided with a check valve as additional safety precaution. Follow local legislation in force at any time.



ATTENTION! The water supply should be provided with a meter to avoid spillage by over-filling. Follow local legislation in force at any time.

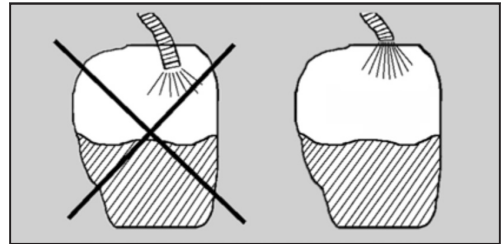

Filling the rinsing tank

The rinsing tank is integrated with the main tank.

Capacity: 40 , 60 or 100 litres for 400, 600 , 1000 and 1200 litres main tanks, litres for 2000 .

The illustration shows the location of the rinse tank. Fill through lid A.



ATTENTION! Only fill rinsing tank with clean water! To avoid algae developing in the rinsing tank always drain the rinsing tank if the sprayer is not in use for a longer period of time.



To clean the tank select "Rinsing tank" on the three-way valve located above the suction filter.

The multi-hole rinsing nozzle is located inside the main tank.

When pressurized the multi hole nozzle will rotate fast and rinse down spray chemical residues from the tank walls. To activate this multi-hole rinsing nozzle for internal cleaning you should turn the tap located on the pressure distributor.



5 - Operation

As this manual does not refer to only one model, since HARDI offers multiple configurations of the same sprayer, the following chapter refers to the available operating units.

Power supply

Power requirement is 12V DC. Always note polarity! For proper function of the electric equipment, the wires must have the following recommended cross sectional areas and correct fuses to ensure a sufficient power supply. The delivered power connectors follow the standard of most of the newest tractors. If you have a tractor with another power connector, it is necessary to disassemble the connector and fit it to the actual tractor connector. The number and the type of connectors may vary depending on the specifications.

When 12 V power is taken from other places than the battery, it often changes in voltage when other power consumption is activated (Air condition on / off ventilator on the radiator on/ off etc.) That assistance in voltage does affect the Spray Computer.

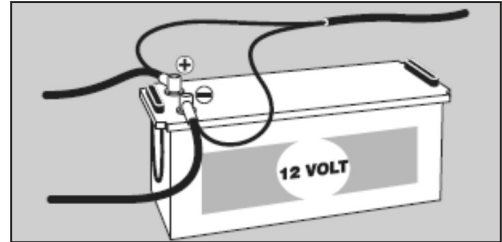

Installation of control unit brackets

Find a suitable place in the tractor cabin to mount the control units. Best recommended position is to the right of the driver seat.

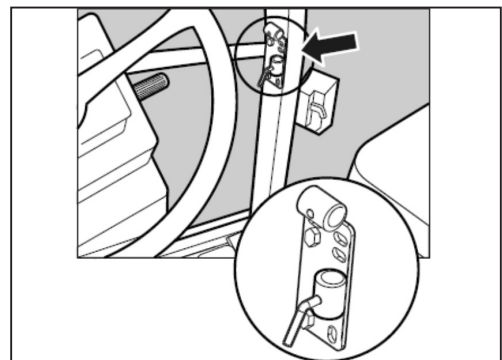

The supplied tractor pillar bracket (A) has a hole spacing of 100 and 120 mm that fits most tractors. Threaded mounting holes may be hidden behind the front corner cover. Check tractor instructions manual for information regarding attachment points. Three mounting tubes (B) are supplied. One, two or all three may be used. They can be bent and shortened. A spacer (C) is also supplied to allow further attachment possibilities. Find the best solution for your tractor or vehicle. Tube (B) plate is prepared so that, if correctly orientated, all boxes will line up.

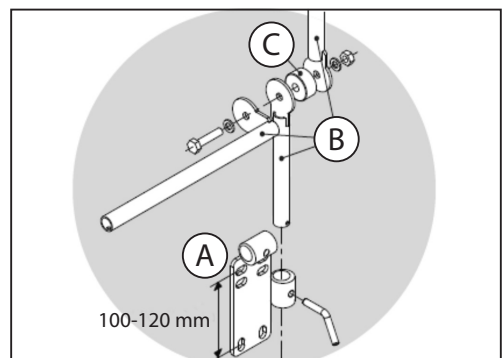

DANGER! turn off any spray computer before you unplug the power supply and cable to the sprayer.

Data transmission must stop, before power supply is stopped.

5 - Operation

SV operating unit

1. Manual pressure regulation, turn left for less pressure, right for higher pressure.
2. The section valve. No adjustment is needed.

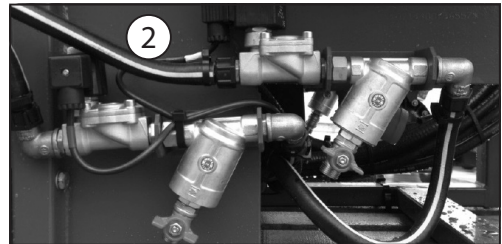
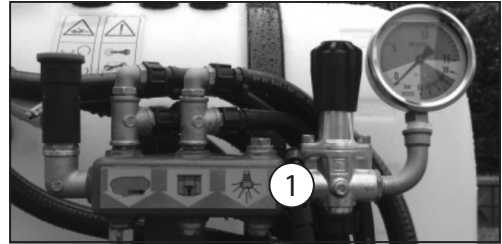

The CA Operating unit: 2, 4 or more sections

1. Constant pressure on the section valve.

Turn left or right to increase or decrease the pressure charge that occurs when turning the section valve off/on.

This is done once for all. If nozzles are changed, it might require repeating the procedure

2. The section valve
3. Bypass valve
4. Pressure regulation
5. Optional flowmeter

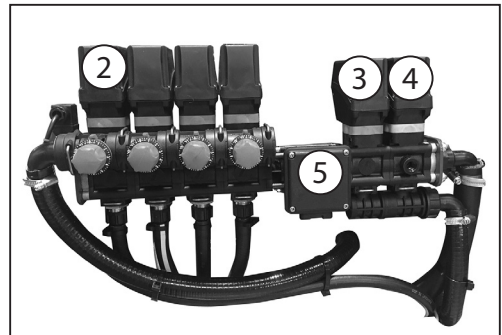

CB operating unit

1. Pressure equalisation device on the section valve.

Turn left, or right to increase or decrease the pressure change that occurs when turning the section on/off.

This is done once and for all. If nozzles are changed, a repetition of the procedure may be required.

2. Pressure regulation, no adjustment is needed.

This photo illustrates a 2 section operating unit CB2.

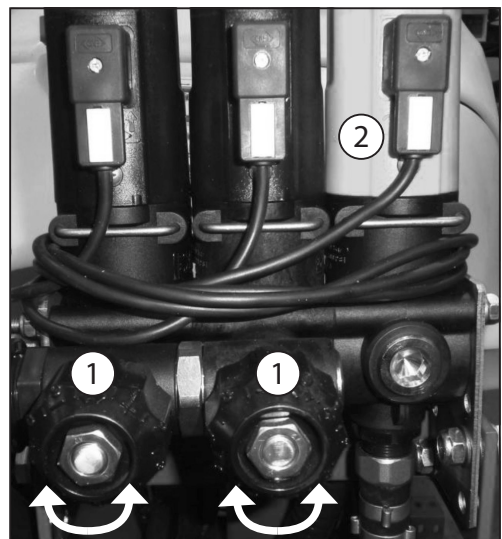

CB operating unit with bypass valve

The operating unit is used in case of low dose rates, as it is often the case in pneumatic sprayers, equipped with an additional bypass valve.

Open the valve to allow a certain quantity of flow return freely to tank. This provides a pressure drop in the system, and allows the pressure A to come very low.

Clock wise = closing

Anti-clock wise = opening

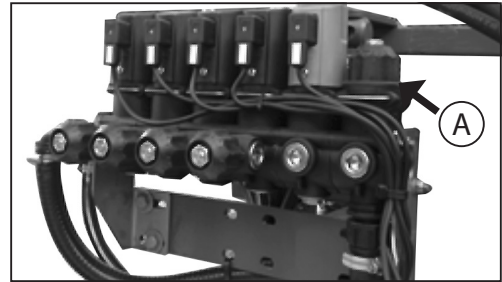

Control boxes

FB 3610

F0. Main Switch valves section

F1-F3 / F2-F4 Fluid sections: Odd on left / Even on right

S1-S2 / S3-S4. Hydraulic selectors

P+ / P- PRESSURE Regulation + & -

STB. ON / OFF

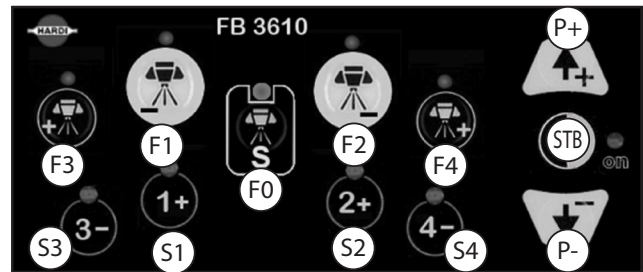

FB 3620

F0. Central fluid section or /

F1-F3-F5 / F2-F4-F6 Fluid sections: Odd on left / Even on right

S1-S2 / S3-S4. Hydraulic selectors

ANG1+ ANG1- / ANG2+ ANG2- Electric piston

L. Lights

M. Mixer

P+ / P- PRESSURE Regulation + & -

STB. ON / OFF

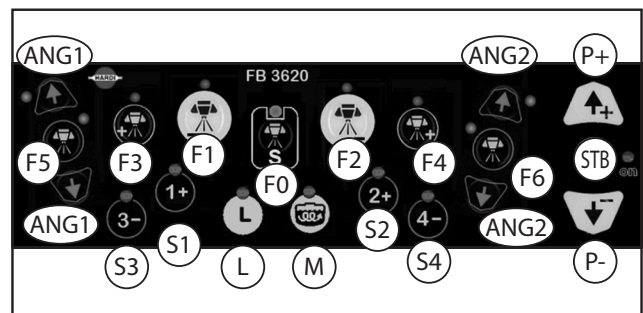

HB 3610

H0+ / H0-. Lift

H1+ / H1-. L Fold / Unfold

H2+ / H2-. R Fold / Unfold

H3+ / H3-. L Variable geometry

H4+ / H4-. R Variable geometry

STB. ON / OFF

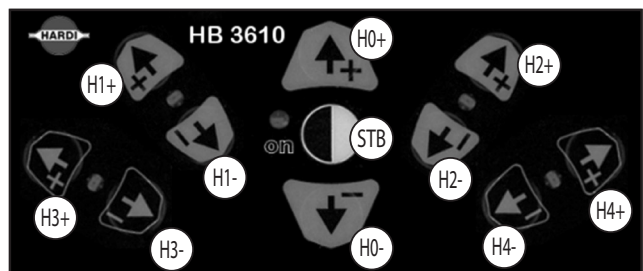

5 - Operation

The Joystick S selector

Remove the rubber protection in the lower end; screw it onto the hydraulic lever by means of the nut fitted inside the Joystick.

Connect the power plug to 12 V and connect the universal connection plug to the sprayer.

Push the lever / joystick forward without pressing any button and the lift will go up.

Push forward the lever / joystick, and press on the top left button and the left boom wing will fold out. The other way round it folds.



HB 3620

H0+ / H0-. Lift

H1+ / H1-. L Fold / Unofld

H2+ / H2-. R Fold / Unfold

H3+ / H3-. L Variable geometry

H4+ / H4-. R Variable geometry

H5+ / H5-. L Paralelogram variable geometry

H6+ / H6-. R Paralelogram variable geometry

H. Auto-variable geometry

T. Track (T and then buttons *)

D. Direction (D and then buttons *)

B. Block

A. Aditonal (A and then Hxx buttons)

STB. ON / OFF

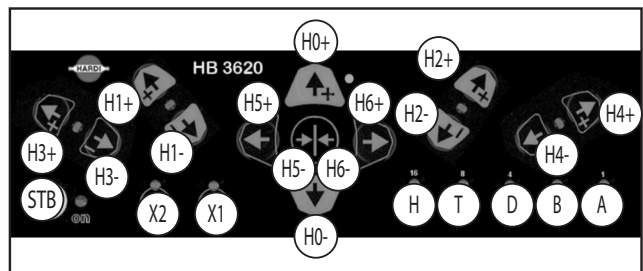

Cannon L-M-T

Hydraulic engine 180° turn = 1 double acting outlet

Spout lifting cylinder = 1 double acting outlet

Hydraulic control of the CANNON

The operating ranges of all three CANNON models are the same.

The lifting cylinder is controlled via a double acting outlet on the tractor and can be set vertically between -10 to 80° compared to horizontal.



The spout can be rotated 180° by another double acting outlet. This allows treatment to either side independently of the driving direction.

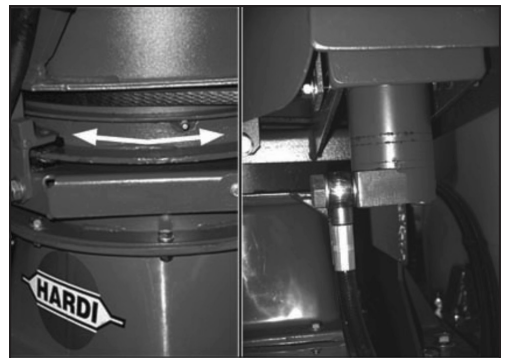

The hydraulic adjustment

The joystick activates the solenoids on the hydraulic block.

The oil flow from the tractor is different from model to model. Adjust the flow on indicated Allen bolt:

in = slows down out = speeds up

The boom must move slowly in all moves.

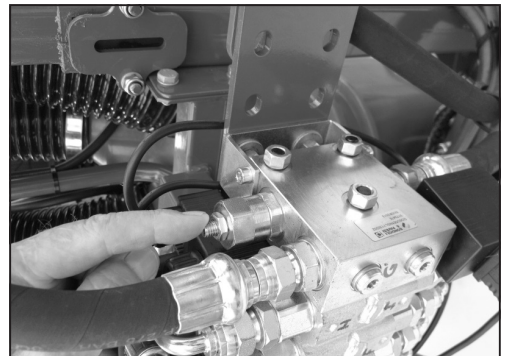

Throttle valves

Larger vine booms are as well equipped with throttle valves, in order to make an individual adjustment of the speed in the hydraulic cylinders. Clockwise to reduce oil flow.



5 - Operation

Vegetation sensor is optionally equipped

Opens and closes automatically if tree or bush is detected.

A time delay in opening and closing is programmed in the control box.

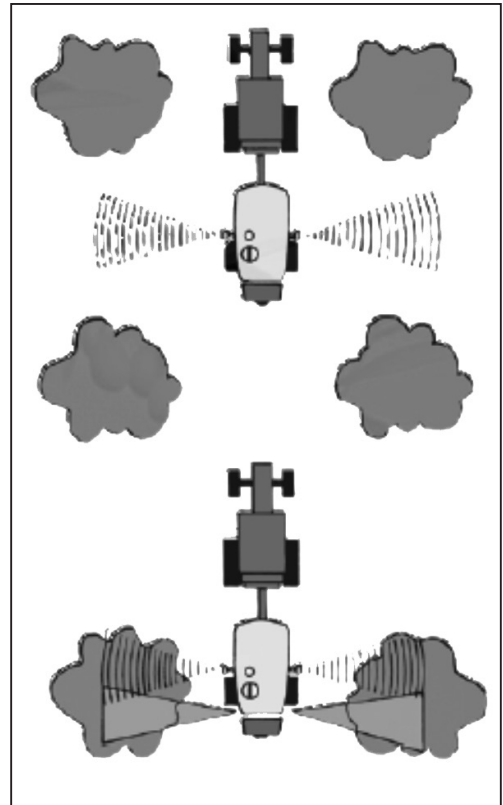

Rate controller DB3610



1-2-3-4. Fluid section. Odd on left / Even on right

5-6-7-8. Hydraulic selectors

9. Menu/Left

10. Up

11. Escape/Right

12. Down

13. Enter/Regulator

14. ON-OFF sonars/Screen views

15. ON/OFF/Pause

5 - Operation

Rate controller DB3620

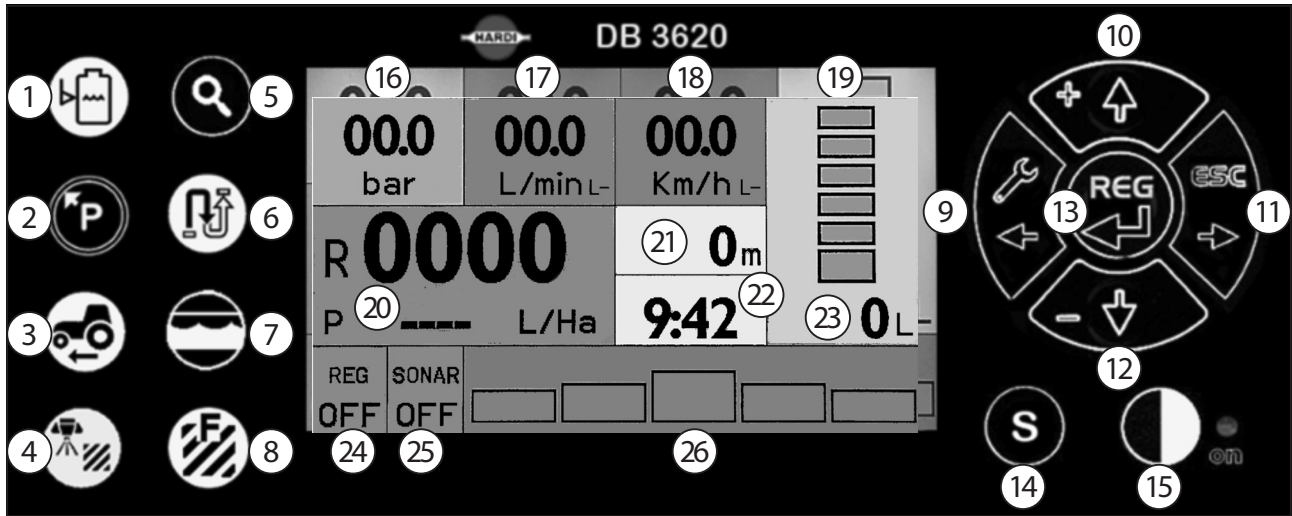

1. Tank shortcut
2. Pressure shortcut
3. Velocity shortcut
4. L/Ha shortcut
5. Change screen
6. Info menu
7. L/min shortcut
8. Land shortcut
9. Menu/Left
10. Up
11. Escape/Right
12. Down
13. Enter/Regulator
14. ON/OFF sonars
15. ON/OFF/Pause
16. Pressure
17. Flow in litres per minute
18. Speed
19. Tank level
20. Application dose R-real P- programed
21. Remaining capacity according to tank level
22. Time
23. Tank level
24. Rate controller in ON or OFF
25. Optional vegetation sensors
26. Section of operating unit

Above picture illustrates the rate controller / Spray computer DB3620.

It is the largest in the rate controller family 3600, with colour display. The rate controller DB3610 is very similar in function, but smaller and with the screen in black and white, versus the larger version which is in colour.

The functionality of the smaller DB3610 is identical,

Extended joystick

- H0+ H0-. Lift
- H1+ H1-. L Fold
- H2+ H2-. R Fold
- H3+ H3-. L Variable geometry
- H4+ H4-. R Variable geometry
- H5+ H5-. L Paralelogram variable geometry
- H6+ H6-. R Paralelogram variable geometry
- F0. Central fluid section or Sonar
- F1-F3-F5 / F2-F4-F6. Fluid section.
Odd on left. Even on right
- C1. Configurable 1
- C2. Configurable 2
- C3. Configurable 3
- C4. Configurable 4
- ON / OFF

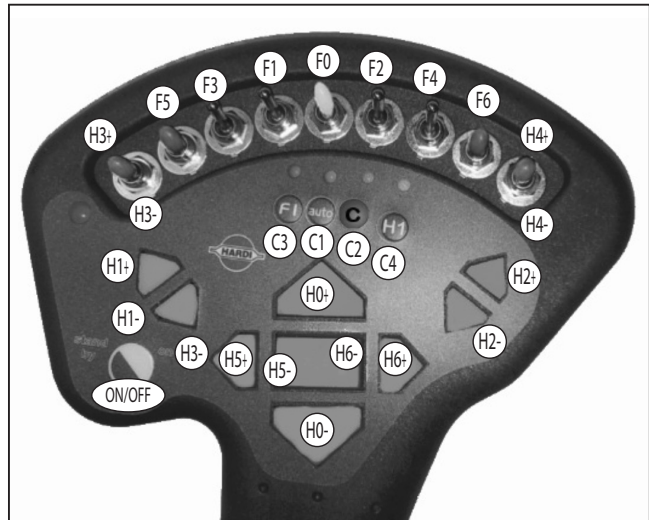

The buttons C1 to C4 allow a second level of buttons to hydraulic functions.

Example of speed and pressure limit settings

The pressure limits are set to 5 and 9 Bar, and speed limits are 2 and 6 km/h.

The pressure will not reach 11 Bar, the limit is 9 Bar.

If the speed is higher than 6 km/h the rate controller will not push up the pressure, as the programed max speed is 6 km/h.

Spray mist continues to flow through the nozzles, when we are beyond the limits, in the "dead zone", but the programed dose rate is no longer achieved. If speed is higher than the limit, we apply less dose rate per Ha. as the pressure does not follow the high speed.

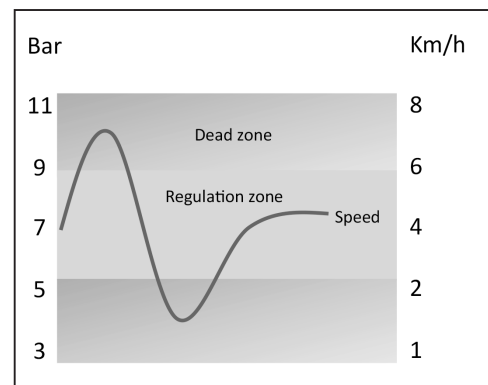

5 - Operation

Cleaning

General information

In order to be able to use your mistblower for many years, a maintenance programme needs to be followed. This programme should include a comprehensive cleaning procedure.



ATTENTION! Always read the individual sections. Carefully read the maintenance task instructions before starting. If any part of these instructions is unclear, for safety reasons, please contact your HARDI dealer for further information.



ATTENTION! A clean mistblower is a safe mistblower.
A clean mistblower is always ready for action.
Clean mistblowers are not damaged by pesticides and their solvents.

Steps to follow

1. Fully read the chemical product's label. Take note of any special instructions regarding protective clothing, deactivating agents, etc. Read the labels on the detergents and deactivating agents. If any cleaning procedure is specified, follow it accordingly.
2. Familiarise yourself with local legislation regarding the disposal of pesticides, mandatory decontamination methods, etc. Contact the appropriate department, e.g. Department of Agriculture.
3. Pesticide washings can usually be emptied out on a soakaway or retained at a washing location (See "Filling/washing location requirements"). This must be an area not used for crop growing. You must avoid seepage or runoff of residue into watercourses, wells, springs, pools, etc. The fluid remaining after rinsing the equipment cannot be disposed of down a sewer. It must be emptied into a suitable soakaway.
4. Cleaning starts with calibration. A properly calibrated mistblower ensures a minimal amount of fluid remaining. **Applying an anticorrosive wax or oil , makes next cleaning much easier, chemicals do not "burn" into the paint work and other surfaces.**
5. It is good practice to clean the mistblower immediately after use, leaving it safe and ready for the next spray job. This prolongs the life of the parts.
6. At times, the spray liquid may need to be left in the tank for a short time e.g. overnight or until weather is suitable for spraying. Unauthorised persons or animals should not have access the mistblower under these circumstances.
7. If the product applied is corrosive, all metal parts of the machine before and after use should be coated with a suitable rust inhibitor, **such anticorrosive wax or oil, as described under suitable lubricants.**

Cleaning and maintaining the filters

Clean filters ensure:

1. Mistblower parts, such as the valves, diaphragms and operating units, are not blocked or damaged during use.
2. Nozzles are not blocked during spraying.
3. The pump has a long service life. A clogged suction filter will result in pump cavitation. The main filter that protects the mistblower parts is the suction filter. Check it regularly.



ATTENTION! It is strongly recommended to pump antifreeze liquid, Glycol "through the entire circuit, move all manifolds valves; let the pressure safety valve pop..
No matter if the machine is in a warm climate, it simply conserves all synthetic part in the circuit.

Cleaning the tank and liquid system

1. Dilute remaining spray liquid in the tank with at least 10 parts of water and spray the liquid out in the crop/orchard just sprayed.
2. Select and use the appropriate protective clothing. Select detergent suitable for cleaning and suitable deactivating agents if necessary.
3. Rinse and clean mistblower and tractor externally. Use detergent if necessary.
4. Remove tank and suction filters and clean. Be careful not to damage the mesh. Replace suction filter top. Replace filters when the sprayer is completely clean.
5. With the pump running, rinse the inside of the tank. Don't forget the tank roof. Rinse and operate all components and any equipment that have been in contact with the chemical. Before opening the distribution valves and spraying the liquid out, decide whether this should be done in the field again or on the soakaway.
6. After spraying the liquid out, stop the pump and fill at least 1/5 of the tank with clean water. Note that some chemicals require the tank to be completely filled. Add appropriate detergent and/or deactivating agent, e.g. washing soda or Triple ammonia.
7. Start the pump and operate all controls enabling the liquid to come into contact with all the components. Leave the distribution valves until last. Some detergents and deactivating agents work best if left in the tank for a short period. Check the label.
8. Drain the tank and let the pump run dry. Rinse inside of the tank, again letting the pump run dry.
9. Stop the pump. If the pesticides used have a tendency to block nozzles and filters, remove and clean them immediately.
10. Replace all the filters and nozzles and store the mistblower. If, from previous experiences, it is noted that the solvents in the pesticide are particularly aggressive, store the sprayer with the tank lid open.



ATTENTION! It is advisable to increase the forward speed (double, if possible) and reduce the pressure to 1.5 bar (20 psi) when spraying diluted remaining liquid in the field just sprayed.



ATTENTION! If a cleaning procedure is given on the chemical label, follow it closely.



ATTENTION! If the sprayer is cleaned with a high pressure cleaner, lubrication of the entire machine is recommended.

Use of rinsing tank and rinsing nozzles (optional)

The incorporated rinsing tank can be used for two different purposes.



ATTENTION! If a cleaning procedure is given on the chemical label, follow it closely.

In-field diluting before cleaning

In-field diluting of remaining spray liquid residue in the spraying circuit, before cleaning the sprayer.

Rinsing the tank and liquid system

1. Empty the sprayer as much as possible. Close the Agitation Valve (no agitation) and spray till air comes out of all nozzles.
2. Turn suction valve towards "Rinsing tank" and pressure valve towards "Spraying".
3. Engage and set the pump at approximately 300 r.p.m.

5 - Operation

4. When 1/3 of the contents in the rinsing tank is used, turn suction valve towards "Main tank" and operate all valves on the pressure side of the system in the following order so that all hoses and components are rinsed:
 - I. Turn the pressure valve towards TurboFiller (if fitted) and open the TurboFiller suction valve.
 - II. Open TurboDeflector valve and close it again when clean water comes out of nozzles.
 - III. Close TurboFiller lid and squeeze the Chemical Container Cleaning grip to clean this device.
 - IV. Open TurboFiller lid again and make sure that TurboFiller is empty.
 - V. When empty, close the TurboFiller suction valve again.
 - VI. Turn the suction valve towards "Main tank" and the pressure valve towards "Spraying" and spray the liquid in the field just sprayed.

Cleaning of Main tank

5. Turn the suction valve towards "Rinsing tank" and the pressure valve towards "Internal Tank Rinsing". Remove the filling strainer to avoid any cleaning shadows behind it.
6. When another 1/6 of the contents in the rinsing tank is used, turn the suction valve towards "suction from Main tank".
7. Turn pressure valve towards "Spraying" and spray the liquid in the crop/orchard just sprayed.
8. Repeat point 6 - 8 one more time.



WARNING! When critical chemicals have been used, before spraying another crop/orchard sensitive to the chemical just used or a cleaning detergent it is highly recommended to do an extra cleaning:

9. Fill the rinse tank again.
10. Fill the main tank with 500 l clean water.
11. Add the **cleaning detergent** to the main tank by using the TurboFiller. Follow instructions on the label of the cleaning agent. Ask your chemical dealer for appropriated cleaning detergent, likewise deactivating agent as ALL CLEAR® EXTRA or washing soda (caustic soda ash), or Triple ammonia cleaning detergent.
12. Clean the whole system again.
13. To get the best cleaning effect the Self-Cleaning Filter and the Suction Filter sieves should be washed with clean water.
14. Rinse the sprayer with clean water afterwards. Then mix in glycol / antifreeze liquid, or cooking oil diluted in water, to conserve liquid circuit.



ATTENTION! The rinsing nozzles cannot always guarantee a 100% cleaning of the tank. Always clean manually with a brush afterwards, especially if crops sensitive to the chemical just sprayed are to be sprayed afterwards!

Rinsing when main tank is not empty

Rinsing the pump, operating unit, spray lines, etc. in case of stop in spraying before main tank is empty (e.g. beginning rain etc.).

Cleaning of the liquid system:

1. Turn suction valve towards "Rinsing tank". (Keep pressure valve in "Spraying"-position).
2. Close Agitation Valve (no agitation).
3. Engage the pump and spray the water from the rinsing tank in the field until all nozzle tubes/nozzles have been flushed with clean water.
4. Disengage pump again.

5 - Operation



ATTENTION! It is advisable to increase the forward speed (double, if possible) and reduce the pressure to 1.5 bar (20 psi) when spraying diluted remaining liquid in the field just sprayed.



ATTENTION! If the sprayer is cleaned with a high pressure cleaner, lubrication of the entire machine is recommended.

6 - Maintenance

Lubrication

General information

Always store lubricants clean, dry and cool - preferably at a constant temperature - to avoid contamination from dirt and condensed water. Keep oil filling jugs, hoppers and grease guns clean, and clean the lubricating points thoroughly before lubricating. Avoid skin contact with oil products for longer periods.

Always follow the quality and quantity recommendations. If no quantity is recommended, feed the lubricator until new grease becomes visible.

Pictograms in lubrication & oiling plans designate:

1. Lubricant to be used (see "Recommended lubricants" below).
2. Recommended intervals. Shown in hours or with a symbol for occasional maintenance.
3. Amount to be used. Only shown if an amount is specified.

 ATTENTION! If the sprayer has been cleaned with a high pressure washer, lubrication of the entire machine is recommended.

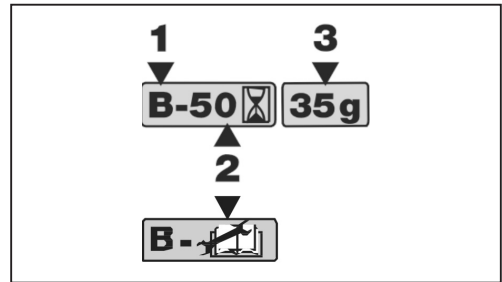



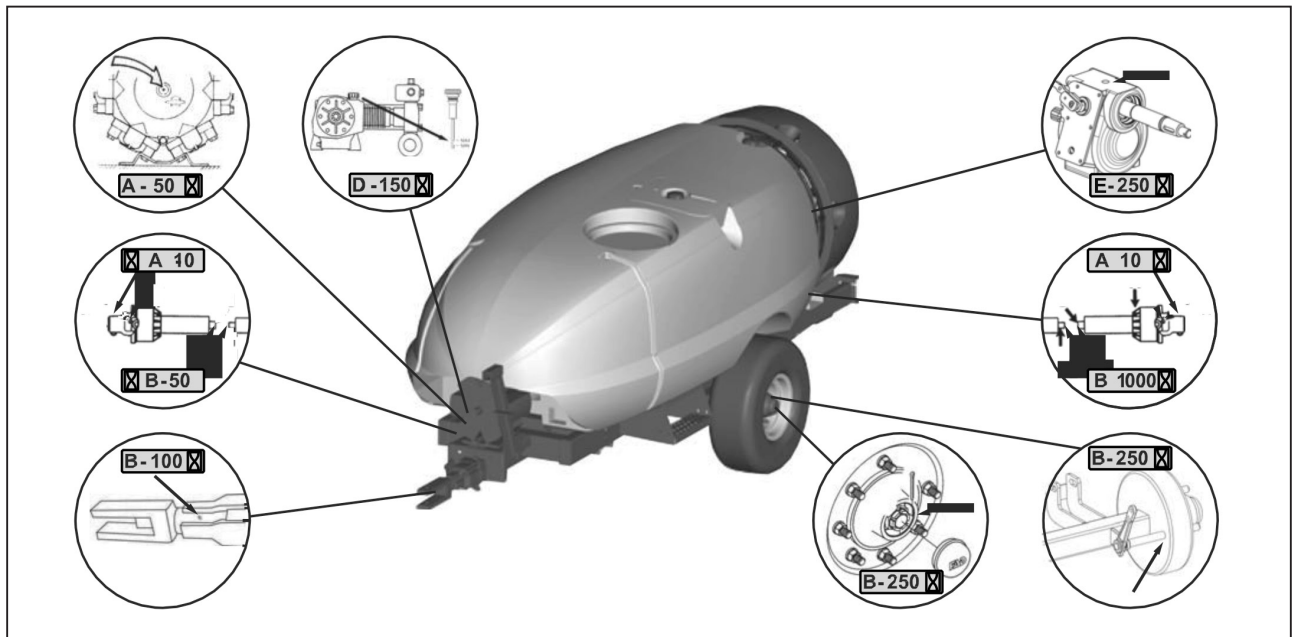









Lubricating and greasing the mistblower



 ATTENTION! Clean the Sprayer after use, as described in the chapter of Cleaning.
Flush liquid circuit with glycol / anti-freeze liquid, or cooking oil diluted in water, to conserve liquid circuit.
Apply on outer surfaces of the sprayer anticorrosive wax or oil.
Caution should be exercised when performing maintenance tasks on the gearbox, it contains oil and must always be handled when the temperature is the correct to avoid burns.

6 - Maintenance

Suitable lubricants

What to Lubricate?	Lubricant Type	Factory Use	Suitable Alternatives
 A BALL BEARINGS and PUMP	Lithium based grease Consistency NLGI grade 2 Viscosity (@40°C) > 460 cSt	SHELL Gadus S3 V550L 1 Hardi pump grease cartridge (400g): Item no. 28164600	MOBIL grease XHP 462 TOTAL Multis Complex SHD 460
 B SLIDE BEARINGS	Lithium based grease Consistency NLGI grade 1/2 Viscosity (@40°C) > 200 cSt	MOBIL XHP 222	SHELL Gadus S3 V220C 2 TOTAL Multis Complex SHD 220
 C OIL LUBRICATION POINTS	Engine or transmission oil Viscosity 20W-50 or 80W-90	OKTractor UTTO GL 4 80W	SHELL Spirax S4 TXM CASTROL ACT EVO 4T MOBIL Mobilube HD 80W/90
 D RUBBER YAW DAMPERS	Synthetic type of grease, e.g. silicone grease i NOTE! Never use a compound with kerosine or mineral oil	Kema Kem-Sil 350 cSt	
 D GLIDE SHOES	Stearic or a non-greasy type of wax		
 D BOLTS STAINLESS DEFLECTORS PAINT WORK	Anti-corrosive wax	PAVA PV 700	TECTYL 506 WD
 D VALVES and SEALS (O-RINGS)	NSF 51, NSF 61 silicone compound	DOW CORNING MOLYKOTE 111 Compound	
 E HYDROSTATIC FAN TRANSMISSION	Hydraulic oil type ISO VG 46, ISO 11158 ASTM D6158-05 DIN 51524-3	OK Hydraulic HVI 46	SHELL Tellus S2 V 46 CASTROL HYSPIIN AWH-M 46 MOBIL DTE Excel 46
 E GEARBOX	Gear oil type ISO VG 220 Fully synthetic	MOBIL SHC 630	SAE 90
 E HYDRAULIC DAMPING CYLINDER	Hydraulic oil type ISO HVLP Wide temperature range DIN 51524-3	CASTROL HYSPIIN AWH-M 68	
 E HYDRAULICS	Hydraulic oil type ISO VG 46, ISO 11158 ASTM D6158-05 DIN 51524-3	OK Hydraulic HVI 46a	SHELL Tellus S2 V 46 CASTROL HYSPIIN AWH-M 46 MOBIL DTE Excel 46
 E HYDRAULIC SUSPENSION	Hydraulic oil type ISO VG 46, ISO 11158 ASTM D6158-05 DIN 51524-3	OK Hydraulic HVI 46	SHELL Tellus S2 V 46 CASTROL HYSPIIN AWH-M 46 MOBIL DTE Excel 46

6 - Maintenance

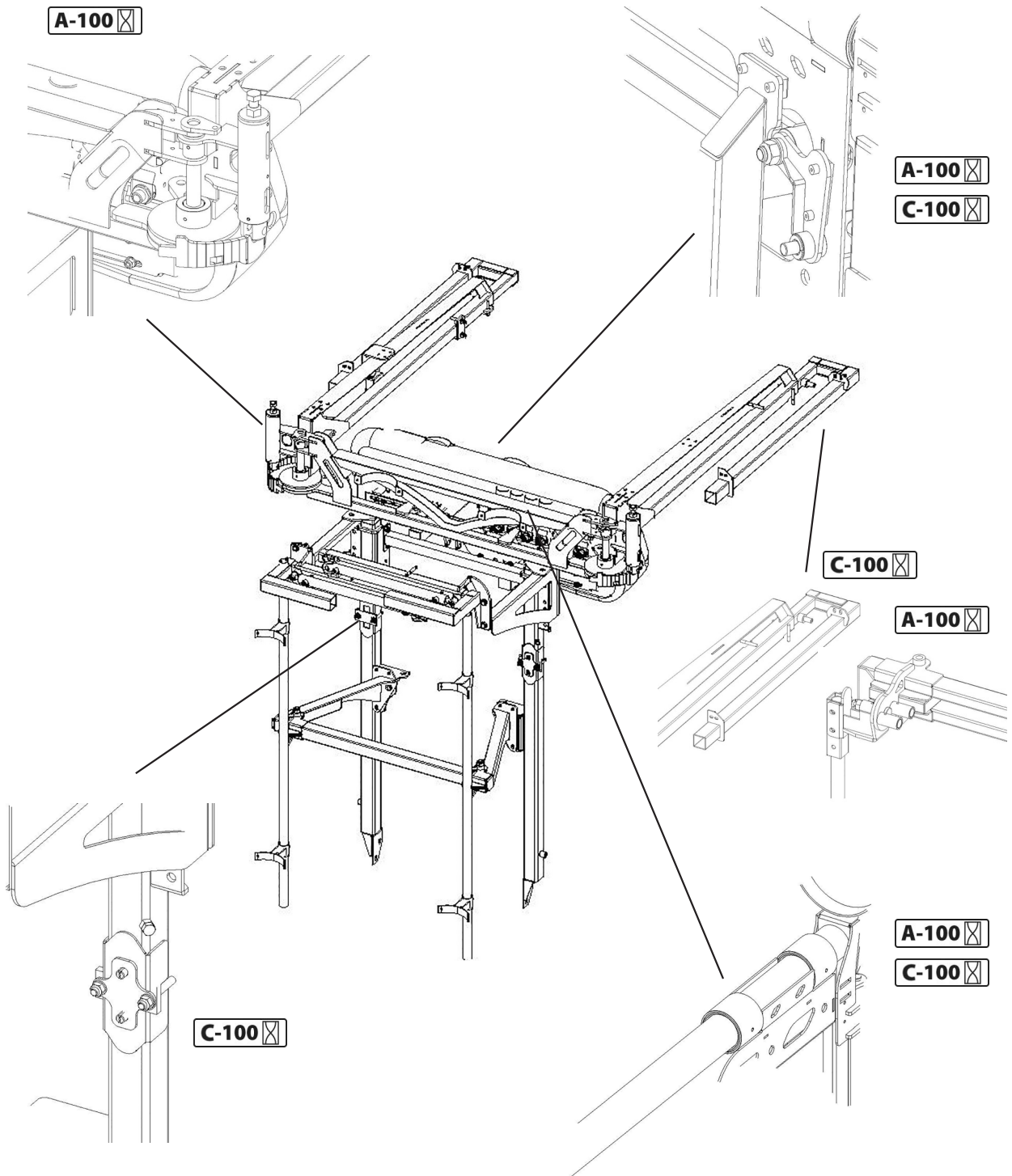

Grease or oil all pivoting, telescoping and moveable parts on all boom and spout types every 100 hours.

It is a general illustration, functions such as Varia and others, might not be present on your machine.

Stop tractor engine while servicing the machine.

6 - Maintenance

Transmission shaft

The universal joints and bearings should be lubricated with grease. At points marked (A), this should be done after every 10 working hours, and the tubes and axles (B) every 50 hours.

Remember to lubricate the joints of the transmission shaft between pump and fan gearbox as well.

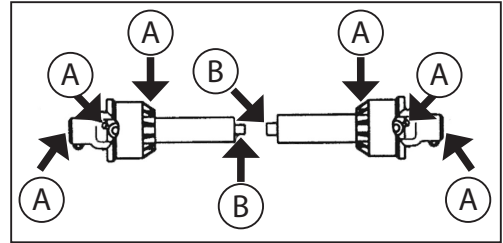

Tank transmission shaft

Loosen the two nuts on the PTO protection in ends, pumps and gearbox.

Twist and pull back the protection.

Grease the yoke.

Put back both protections and tighten the nuts.

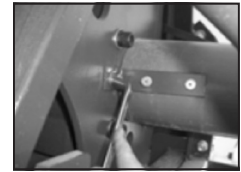
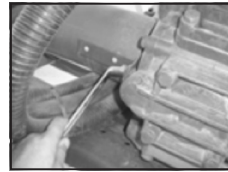

B-50 

Diaphragm pump

Grease the pump every 50 working hours or once a month through the grease nipple located at the crankshaft axle. The grease travels along the grooves in the crankshaft to reach the crankcase where it is distributed around bearings, connecting rods, etc.

Greasing is carried out in the same way on both pump models 363 and 463.



ATTENTION! Insufficient greasing of the pump could cause it to overheat and break the mobile parts inside.

Pump models 363 and 464 have external central grease nipples.

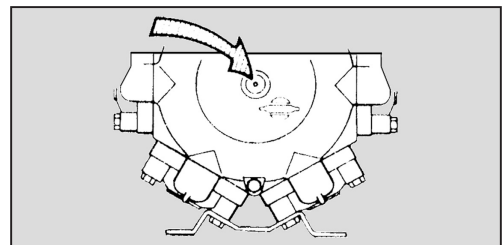

B-50  **35g**

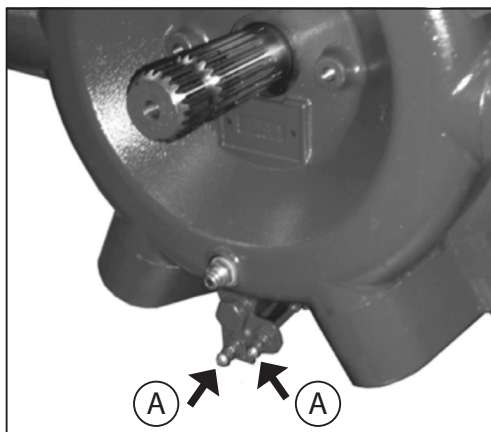

6 - Maintenance

Piston Pump

Check the oil level at regular intervals. This must be between the maximum and minimum marks on the dipstick. The factory always supplies a full pump. Change the oil after the first 50 working hours. The subsequent changes should be carried out every 150 hours or once a year.

MODEL	OIL CAPACITY	TYPE OF OIL	FIRST CHANGE	SUBSEQUENT CHANGES
PS3E 123 L	3.5 L	20/40 HD	50 hours	150 hours
PS3E 147 L	3.5 L	20/40 HD	50 hours	150 hours

Filters and fittings

Inspect the filters every 50 working hours. Apart from ensuring that they are clean, make sure that the mesh is in good condition. Otherwise, the efficiency of the filters will be reduced.

Whenever dismantling a filter or hose pipe, take care not to pinch the o-rings fitted to them. When replacing the pipe fitting, lubricate the o-ring with oil or grease so it seats in the groove.



ATTENTION! If the filter is not in good condition, it could cause numerous unnecessary interruptions during the working day, extending the working time required.



ATTENTION ! Each time you remove a fitting to check the condition of its o-ring or for any other reason, remember to lubricate the O-ring with oil or grease to prevent it from being pinched or breaking when reassembling the fitting in its housing.



ATTENTION! Insufficient greasing of the pump could cause it to overheat and break the moving parts inside.

Fork drawbar

Keep the moving parts greased through the grease nipple to avoid wear and seizing up.

Also grease the contact faces of fork and drawbar.

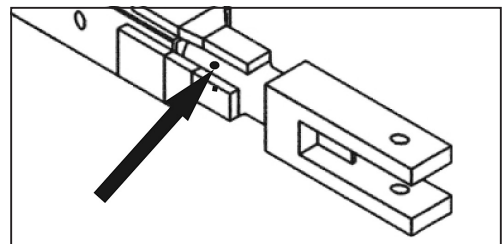

Ring drawbar

Keep the moving parts greased through the grease nipple to avoid wear and seizing up.

Also grease the contact faces of hitch ring and drawbar clevis.

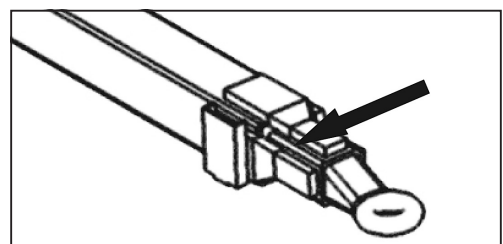

6 - Maintenance

Turnable drawbar

Keep the moving parts greased through the grease nipple to avoid wear and seizing up.

In the pivoting axle of the turnable drawbar a second grease nipple is to be greased.

Also grease the moving parts between pins and lower link balls.

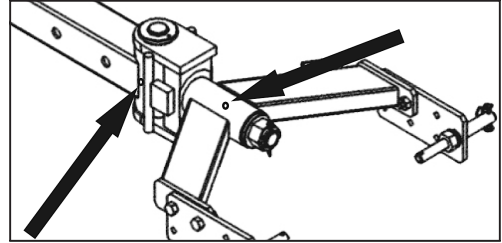

The turnable drawbars, must be greased as per every 100 hours, through indicated grease nipples.

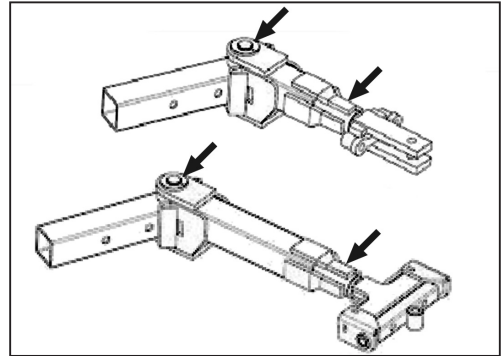

ATTENTION! The turn stop welded to the ball prevents the equipment from performing too tight turns that could cause it to break. Do not force turns beyond this point as this may damage the drawbar parts.



DANGER! Always stop the PTO when taking very tight turns, even when using a transmission shaft with wide-angle CV joint. Tight turns with the PTO on may cause the CV or the pump crankshaft to break and cause major vibrations in the gearbox. This may lead to damages of the fan or air kit.

Axles with brake

The hub is the part of the axle that must be greased. Remove hub cap (A) and grease the inside of the rotating head.

When your machine is fitted with the axle with hydraulic brake, the moving part of the brake (B) must also be greased. Grease at least once a year.

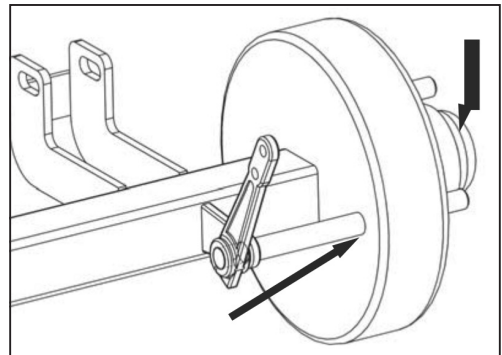

6 - Maintenance

Service and maintenance intervals

General information

The maintenance and replacement intervals of the elements listed as follows will depend on the conditions under which the mistblower will be used, and hence impossible to assess.



WARNING! If you do not feel confident in carrying out some of the maintenance jobs described below, then contact your HARDI dealer's workshop for assistance.

Every 10 working hours – Spray circuit

Fill the tank with clean water, activate all the functions and check for leaks using higher spray pressure than normal.

Check visually the cone of the nozzles to detect for imperfections.

After using the sprayer, hose it down, apply a thin layer of anti-corrosion oil, as described in the table Suitable Lubricants.

Before storing, clean as well the liquid circuit, and mix in anti-freeze liquid or at least sunflower oil or equivalent. Read chapter "Cleaning" for more details.

Every 10 working hours – Suction filter

To service the suction filter, proceed as follows:

1. Undo the nut (A) and open up the filter.
2. Remove the filter (B) from its housing.
3. Replace the O-rings (C) if necessary.

To put it back together:

4. Grease the O-rings.
5. Fit the filter inside its housing.
6. Grease the O-rings inside the cover of the filter.
7. Put the cover back on and tighten it.

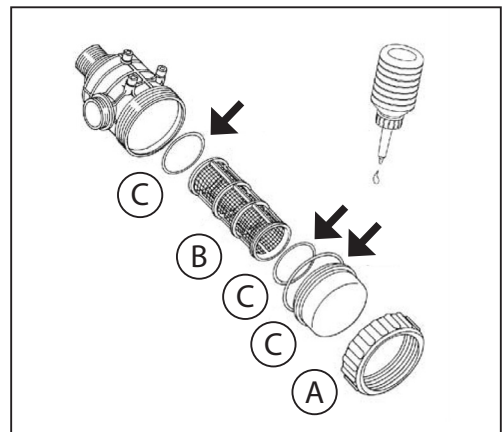

6 - Maintenance

Every 10 working hours – Pressure filters

Remove the pressure filter, unscrew the filter housing to inspect and clean the filter. When you reassemble the filter, grease the o-ring.

There are different mesh sizes. See the section “Technical specifications- Filters and nozzles”.

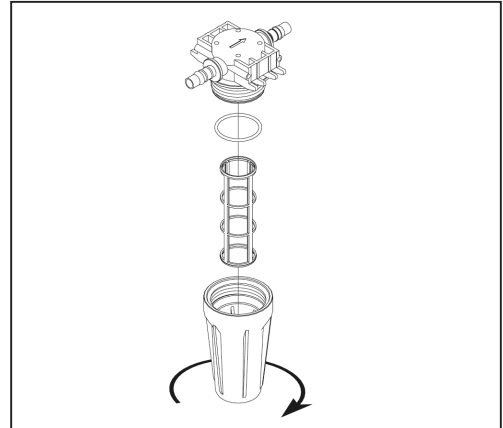

Inspect daily the oil level on the gear box.

Vine sprayers, at the galls level indicator.

Orchard sprayers, at the glass indicator on the gear box.

Change once per year.

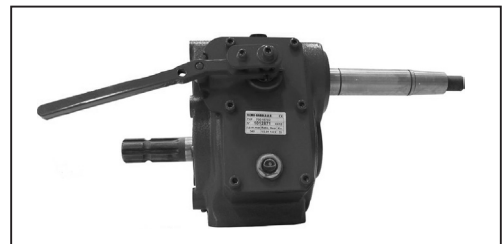

Air sprayers with axial fan equipped with DUO or Jet deflector and or Turbine air sprayers (Vine sprayers) have an external level indicator, as the access to the inspection glass on the gear box is hidden on those models. All other models need to be inspected on the gearbox glass.



Every 10 working hours – Nozzles

To clean or replace the nozzles, use a spanner to undo the nut (D).

Remove the nozzle and clean it with air, water or a toothbrush.



ATTENTION! Never use a piece of wire or a needle as this could cause irreparable damage to the nozzle.

If any of the nozzles leak when closing the spray section valve, the non-drip diaphragm should be replaced.

The nozzles should be replaced when their unit flow varies more than 10%. Worn or damaged nozzles may cause crop damages or insufficient results.

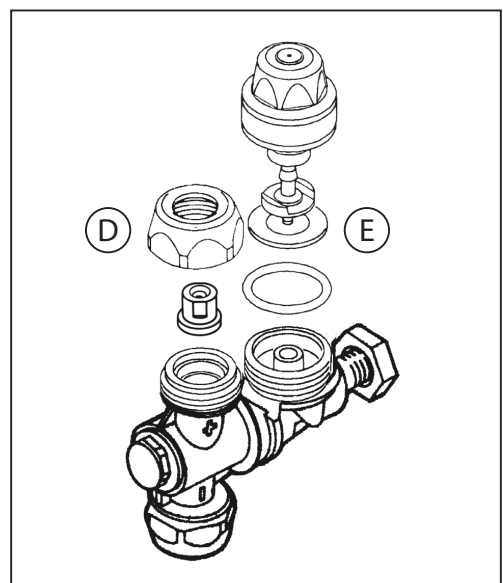

6 - Maintenance

Every 50 working hours – Transmission shaft, chassis, air pressure and diaphragm pump

Check the condition of the transmission shaft protection guard. Replace any damaged parts as required.

Re-tighten the bolts of the wheels and the areas under the greatest stress or torque.

The tire pressure must be periodically checked, this pressure is indicated on the tire itself installed in the equipment.

Inflation and checking should always be done cold.

Check/adjust pressure in pump pressure pulsation damper.

Grease the diaphragm pump.

Every 100 working hours – Drawbar

Grease the drawbar or ball of the mistblower.

Check that the pivoting axles are not blocked or deformed.

Grease and oil all moveable parts.

Every 250 working hours – Wheels, brakes, hoses and gearbox

Check and grease the hub and the wheel braking system.

Verify the hydraulic brake.

Check all the hoses in the circuit.

Check the gearbox support and re-tighten the bolts holding it in place.

Every 1000 working hours – Full service

Perform a full service on all the parts described previously.

Change the gearbox oil.

Dismantle and grease the transmission shaft and joints going through the main tank.

Dismantle the fan clutch and clean/lubricate.

Every 1000 working hours - Gearbox oil change

Change the oil after the first 150 working hours then every 1000 working hours or once a year - whichever comes first.

Run the mistblower until the gearbox has reached normal operating temperature before draining the oil.



Clean the pump and area around dip stick, and drain plug before changing the oil.

Fill with Fresh oil until the level reaches the level hole (B) Capacity: Approximately 1.25 litres.

A. For Oil filling (SAE 90)

B. Oil Level indicator

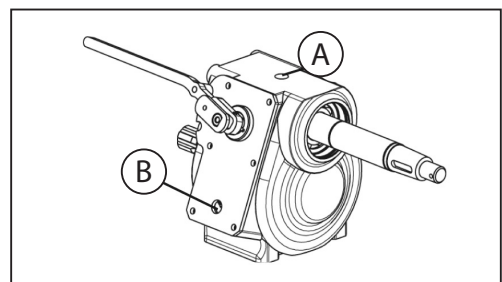

Every 1000 working hours - Fan clutch inspection

Every 1000 working hours or once a year the fan clutch is dismantled for inspection, cleaning and lubrication.

1. Remove the fan clutch from the fan using the puller tool (Part No. 289659).
2. Remove the springs (A) and the two wings (B) using a mallet.
3. Polish the two axles (C) of the core with a fine emery cloth to remove dirt and rust.
4. Also polish the inside hole of the wing (D).
5. Check that the discharge hole in the ferodes (E) is not blocked.
6. Lubricate the axles of the wings and inside the core lightly with oil before re-assembling.
7. Check that the springs still work properly.
8. Re-assemble in reverse order.



WARNING! If the clutch is not maintained it may malfunction and cause severe damages to the fan unit!

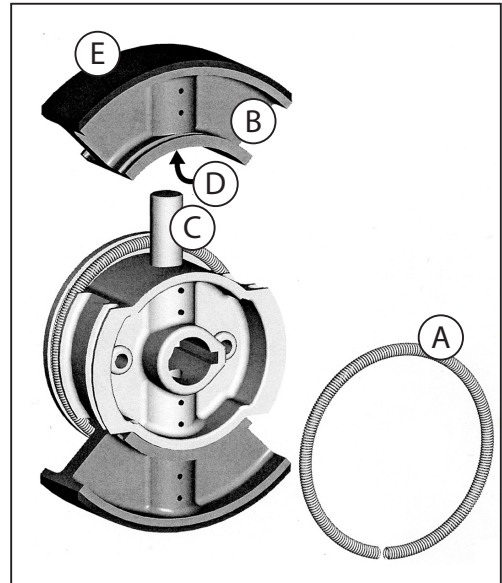

6 - Maintenance

Annual maintenance of tank PTO

The PTO through the tank must be kept in good condition and well-greased to secure it telescopes.

If it does not, it will provoke destructive pressure against the pump and gear box.

A non-telescoping PTO as well might provide destructive vibrations in the spray.

Unbolt the PTO from pump and gear box.

Unbolt and take the pump out with a crane.

Take the PTO shaft out.

Pull the PTO apart in male and female parts.

Clean it well.

Grease it.

Grease Gearbox PTO tap and pump PTO tap.

Put back in the PTO shaft and bolt on the gear box tap.

Put back the pump with a crane and bolt it to the chassis.

Bolt on the PTO to the pump.

Remember weekly PTO greasing / every 50 hours of the tank PTO.



WARNING! If the transmission shaft is not cleaned and lubricated as described it will not be able to extend or retract during operation when load is applied. This may overload the bearings on pump and gearbox or cause vibrations in the transmission and fan!

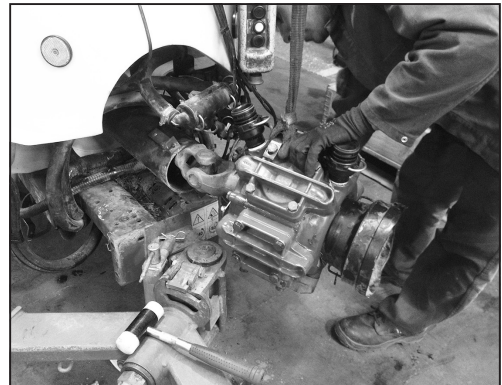

Occasional maintenance

Replacing the 321 valves and diaphragms

Diaphragms

Dismantle the crankcase (4). Now, the diaphragm (5) can be replaced. Grease the pump if the liquid has leaked to the inside. Make sure that the draining hole is not obstructed. Reassemble the pump again.

Torque settings for the 321 are:

Crankcase: 60 Nm / 44.4 lbft.

Crankshaft: 70 Nm / 51.8 lbft.

Diaphragm screws: 60 Nm / 44.4 lbft.



WARNING! Before assembling the covers, turn the shaft with the hand and make sure that the connecting rods are ascending and descending respectively. If not change the position of the 4 connecting rods. The first connecting rod must be assembled towards the right-hand side.

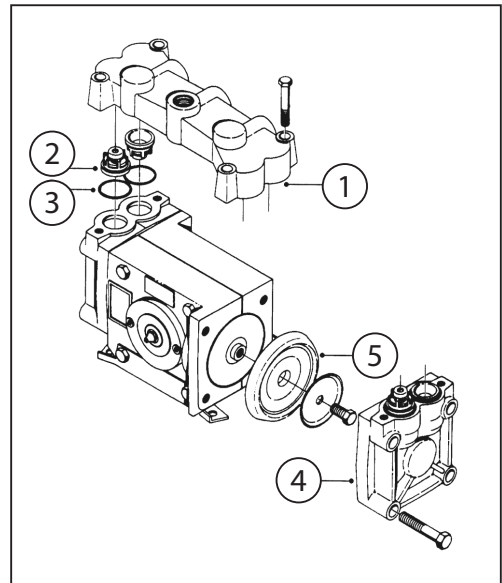

SV operating unit

The SV operating unit open and close via a pilot line as in picture A, a small piston activated by the solenoid, opens up a small hole, hereinafter the liquid pressure opens up the larger diaphragm B in the valve, and allows the liquid to flow to the nozzles.

The pilot line can get blocked due to sedimentation of chemicals.

Unscrew the 4 Allen bolt, lift up the piston as in picture A, rinse out and reassemble.

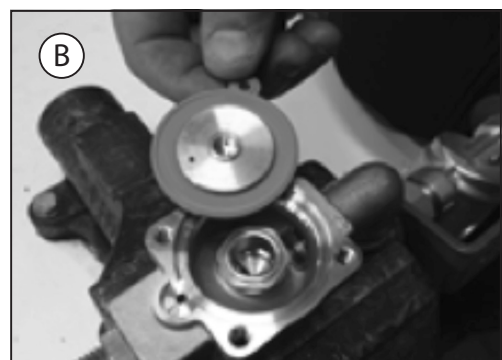
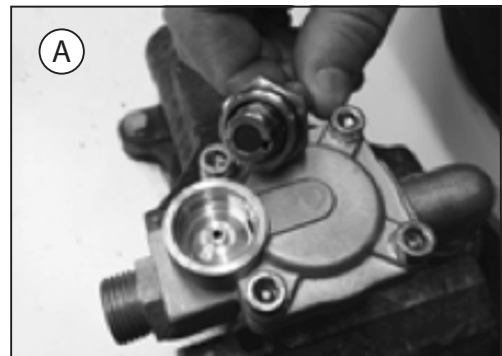

6 - Maintenance

CB Section valve

The CB operating motor valve, is fitted with an end stop, a micro switch. It can be worn out, if that is the case, the electrical supply is not cut by the micro switch. Therefore the motor keeps turning unlimitedly.

It will burn the fuse.

Pull out the clip as illustrated, lift gently up the gear motor, replace the micro switch as illustrated in the picture showing the gear motor end.

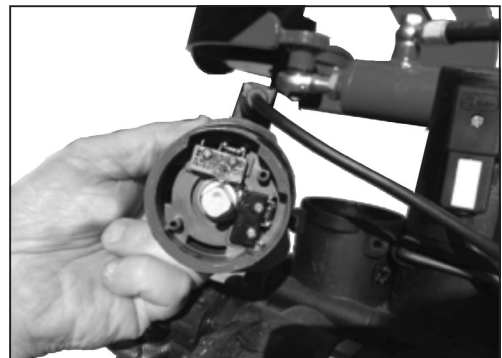
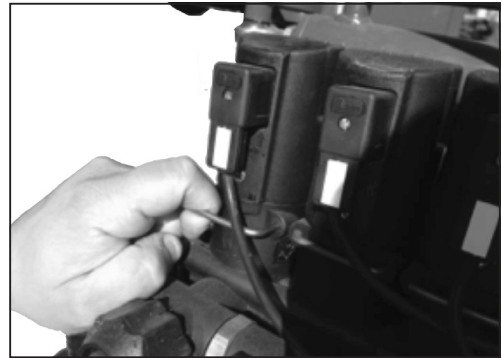

Sealing in the operating unit.

Wear and tear parts in the on/off function of the valve, need to be replaced if the nozzle keeps on spraying weakly after closing a section or the main valve.



6 - Maintenance

Apply thread sealant on the seat and screw it on the end of bypass hole up to beat. Use the socket wrench. Do not exceed with torque.

Apply the thread sealant on sleeve assembly, and tighten on valve body up to beat using the wrench.

Tighten up to beat the stud B on the seat forcing lightly to obtain a tighten connection.

Insert spring and lock into sleeve.

Apply some lubricant inside handle. Place sealant at the end of stud B thread and screw on handle C up to overlap the last notch on valve body.

Screw on and lock up to beat the nut holding the handle while tightening.



WARNING! To operate the gear motor unit 1, install 1.25A fuse on 12Vdc line.

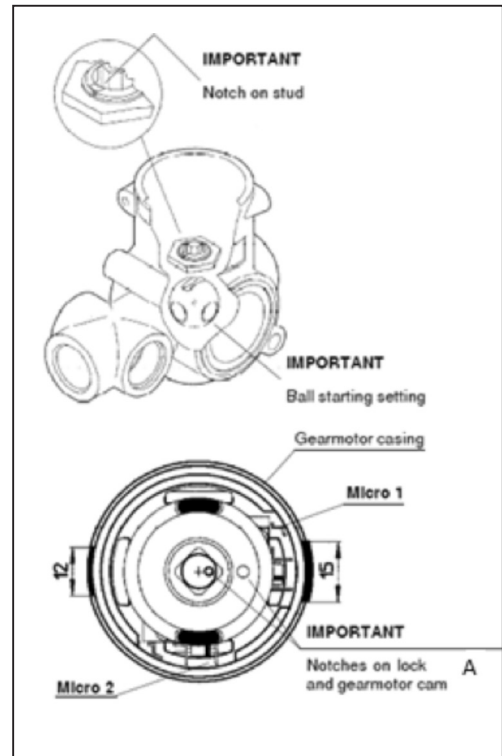

The mark on lock A and gear motor cam must be aligned as illustrated. These marks are referred to notch on gear motor crankcase. To obtain the correct position, connect the brown cable to + pole of battery and the blue one to - pole.

Lubricate the gear motor crankcase and O Rings. Insert the gear motor unit inside the valve body. The gear motor cap must beat on valve body.

Assemble the lock.

Assemble all accessories and connect wiring.



ATTENTION! Brown cable to + pole to obtain this position



6 - Maintenance

Cleaning the air kit



ATTENTION! Never access area or adjust deflector or any other part near the air kit, while tractor is started.



Cleaning of air kit: to prevent unbalance that can cause danger destructive vibrations with dangerous outcome for surroundings.

Inspect for dust and or dirt sedimentation in the air kit.

Hose out the air kit occasionally to prevent dust sedimentation to build up. If it built up, and drop of in uneven locations, it creates unbalance in the air kit, and destroys drive line and the air kit itself.

Rinse the fan blade and inner fan house wall and back end of the air kit. The axial air is designed with natural drain that will let the water out on left and right side.



Do not rinse with high pressure on sealing, as e.g. in the centrifugal clutch area, see separate chapter for clutch maintenance.

The turbine air kit is fitted with a drain plug that must be removed when rinsing out the dust and other dirt sedimentation from the turbine.

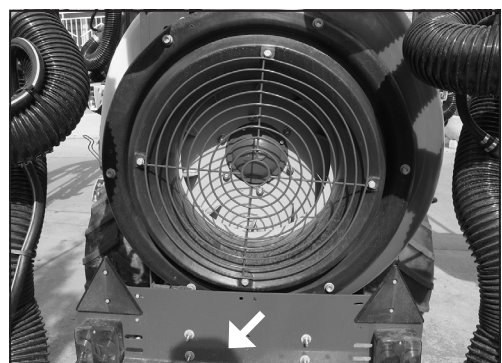
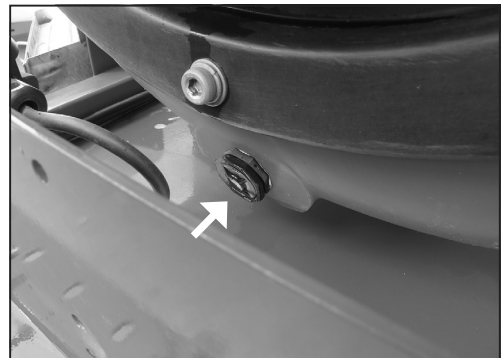
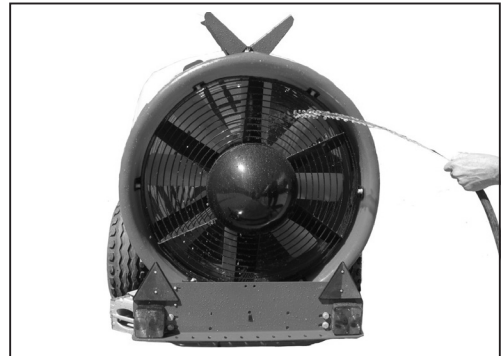

Tank level indicator adjustment

The level indicator reading should be checked regularly. When the tank is empty, the float should lie on the stop pin, of the rod, and the O-ring on the indicator should be positioned at the top position line (A).

If any deviation is found, pull out the plug (B), loosen screws (C), and adjust the length of the cord.

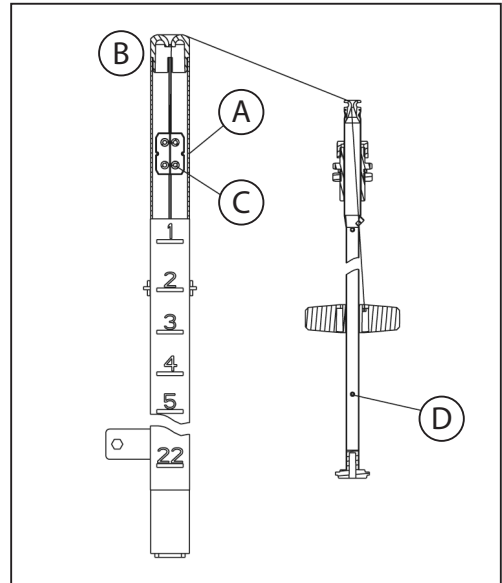

Replacing the valves and 364 and 464 diaphragms

Model 363

The repair kit for the 364 diaphragm pump (valves, seals, diaphragms, etc.) is available under HARDI part No. 75073700.

Valves

Remove crankcase cover before replacing the valves. Remember their direction in order to assemble them correctly afterwards!



ATTENTION! When you remove the crankcase covers, you will see that there are 2 valves that are slightly different from the rest. For correct operation, remember to fit them in the same position and location as before.

Diaphragms

Remove the diaphragm cover. The diaphragm can then be replaced. If the liquid has leaked to the inside of the crankcase, grease the pump thoroughly. Make sure that the drain hole at the bottom of the crankcase is not blocked. Reassemble the pump completely.

The torque wrench settings for the 364 and 464 pumps are the following:

Crankcase cover: 90 Nm

Diaphragm bolt: 90 Nm



ATTENTION! Before tightening the four screws on the crankcase cover, the diaphragms should be centred to ensure correct seating and sealing between the crankcase and the cover. Turn the crankshaft if necessary.

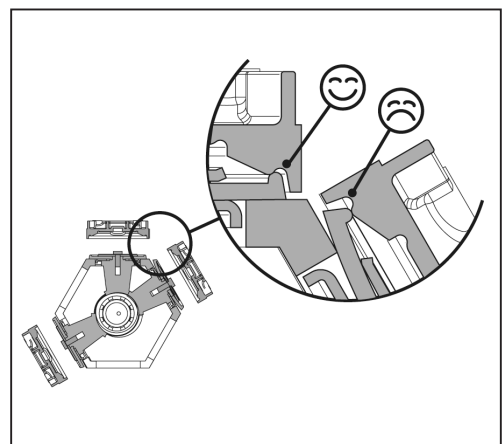
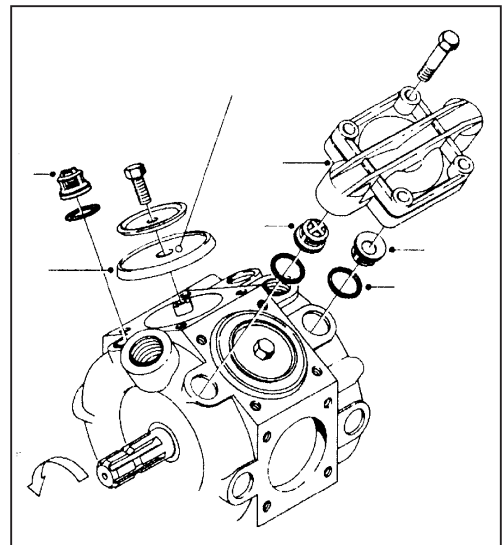

6 - Maintenance

Grease Gun Calibration

Before lubricating the sprayer, you must calibrate your grease gun to ensure that the correct amount of grease is applied to each lubrication point. The correct amount of grease applied will prolong the lifetime of the sprayer.

Calibration example

1. Insert the correct grease cartridge in your grease gun.
2. Apply grease onto a tissue or a piece of paper. Complete 10 full strokes of the grease gun.
3. Place the paper with grease on a scale.
4. If your grease pile weighs for example 10 grams (A), then 1 stroke equals 1 gram of grease.

Once calibrated you can count how many strokes you need to completely lubricate the different grease points on the sprayer according to the specifications.

Alternative method

1. Count the strokes, until you have 10 grams of grease piled up on the scale (A).
2. Now you can figure out how many strokes to use for applying a certain amount of grease to a lubrication point.

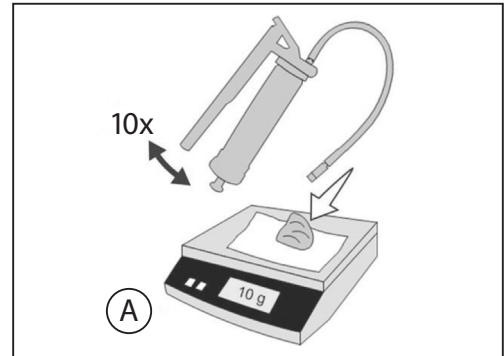

Greasing the Pump

The pump is greased as follows:

1. Factory greased:
300 g grease into each lubrication point (A).
2. Normal operation:
MUST be greased every 50 hours with 30 g grease into each lubrication point (A).
3. After disassembling the pump (diaphragm renewal, etc.):
MUST be greased with 200 g grease into each lubrication point (A).



ATTENTION! In order to avoid excessive wear it is important to use a recommended lubricant! See "Recommended lubricants".



ATTENTION! The pump MUST be stopped during greasing!

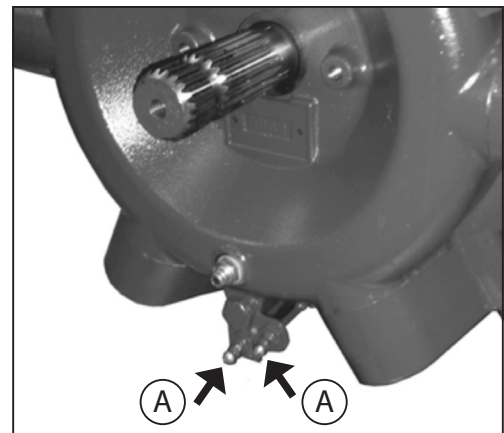

Service and Maintenance Intervals

50 Hours Service - Greasing the Pump

When operating the pump, it MUST be greased every 50 hours with 30 grams of grease into each lubrication point.



ATTENTION! In order to avoid excessive wear it is important to use a recommended lubricant! See "Recommended lubricants".



ATTENTION! The pump MUST be stopped during greasing!

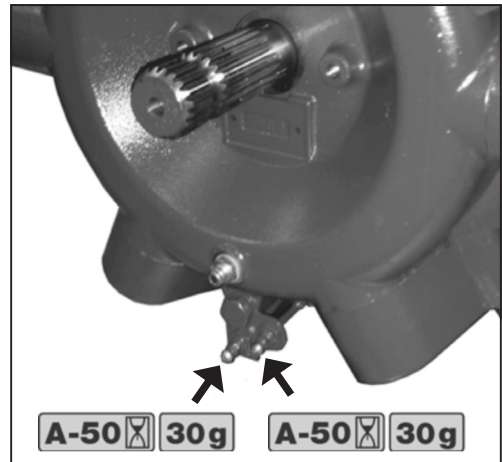

6 - Maintenance

Occasional Maintenance

Lifting and Removing the Pump

When lifting and removing the pump, use a shackle fitted to the built-in lifting eye located between the heads (A).



WARNING! To avoid damages in case of a free-falling pump, use lifting gear and a steel shackle with at least 3.5 tonnes max. tensile strength.



NOTE! Pump weight is approximately 75 kg.

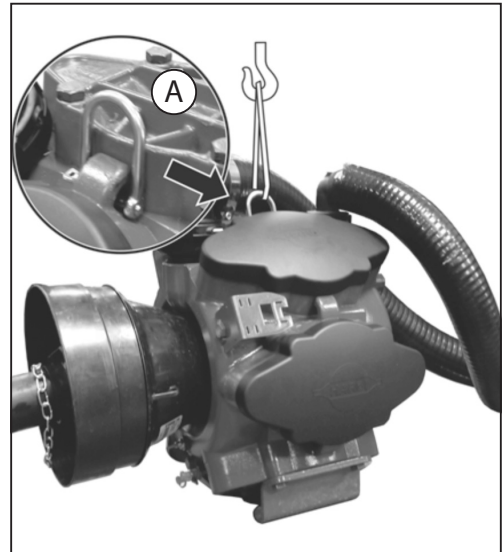

Pump Valves and Diaphragms Renewal

1. Lift off the plastic covers (C) with your hands (A) by pulling with the finger tips while pushing with the thumbs in the centre, as shown in (B).

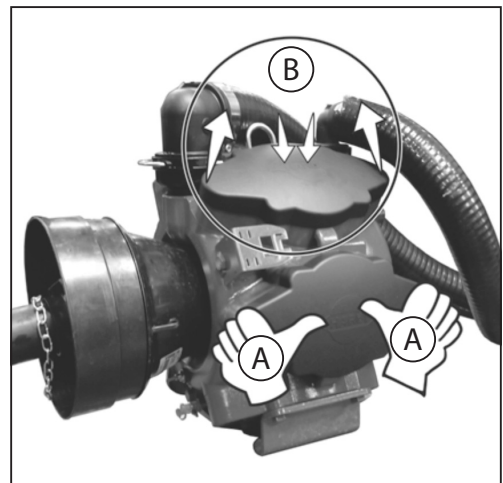

6 - Maintenance

Valves

2. Loosen the 4 head bolts (1).
3. Remove the head (2).
4. Change the valves (3) - note their orientation, so that they are replaced correctly!



ATTENTION! It is recommended to use new gaskets (4), when changing or checking the valves.

Diaphragms

5. Loosen the diaphragm bolt (5).
6. Remove the diaphragm washer (6).
7. The diaphragm (7) may then be changed.
8. Check that the drain hole (8) at the bottom of the pump is not blocked.
9. Apply a small amount of pump grease on the underside of the diaphragms (between diaphragm and conrod washer).
10. Reassemble the pump with the following torque setting.
 - Diaphragm head bolts (1): 90 Nm.
 - Diaphragm bolt (5): 90 Nm.
11. Refit the plastic covers (C).



NOTE! The diaphragm bolt on 1000 r.p.m. pumps must be secured with locking compound.



ATTENTION! Before tightening the 4 bolts for the head (2), the diaphragm must be positioned between centre and top to ensure correct sealing between diaphragm pump housing and diaphragm cover. Turn the crank shaft if necessary.

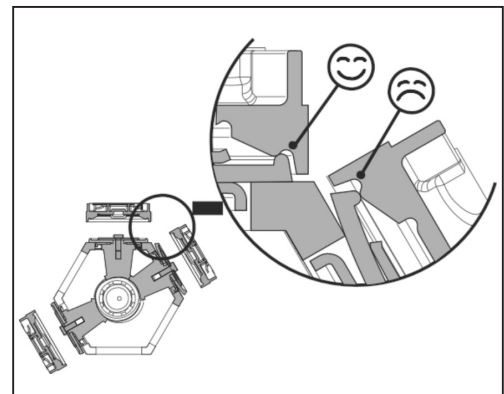
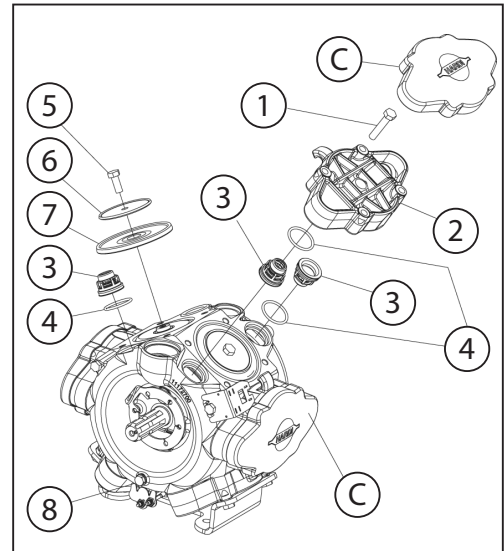

Re-lubrication after assembly

After disassembling the pump (diaphragm renewal, etc.) the pump MUST be lubricated with 200 g grease into each lubrication point. Hardi pump grease cartridge (400g): Item no. 28164600

Overhaul Kit

Pump model: 364 and 464.

Diaphragm pump overhaul kit (valves, seals, diaphragms etc.) can be ordered. Detect the pump model - the overhaul kit can be ordered by your local dealer.

Model 364: Item no. 75585900. Model 464: Item no. 75586000.

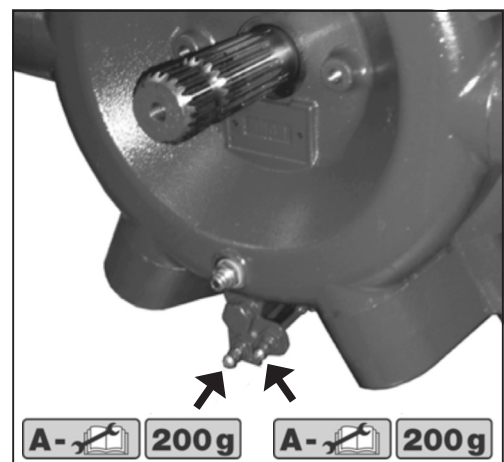

6 - Maintenance

Piston pumps

In order to change the valves and plungers in the case of a fault it is not necessary to dismantle the pump from the mistblower. When chemical product is found to be leaking continuously from the underside of the pump cylinders then there is something wrong with the plungers or the sleeves.

Whenever the pump is dismantled the o-rings must be replaced.

To replace the plungers and the valves follow this procedure:

1. Undo the two upper and six frontal nuts and remove the chambers and cylinder heads.



2. Spread grease on the new sleeves and place the plunger (1) inside.



3. The sleeves have a groove (2) that should be visible in this position.

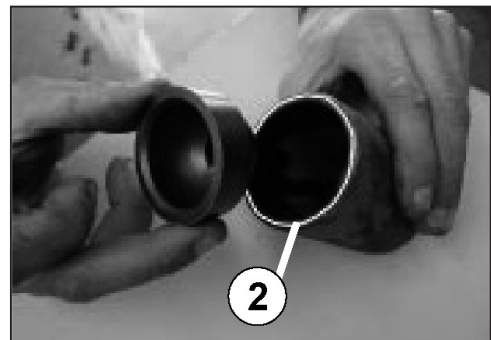

4. Attach the sleeve with plunger to the piston, then the washer (3) and tighten the nut fully.



6 - Maintenance

5. Now fit the cylinder heads (4) and place the nuts without overtightening them.



6. Grease the joints of the six valves before reassembling them.



7. Place the pressure valves on the cylinder heads and the suction valves on the suction chamber.



8. Fit the pressure and suction chambers, and tighten the nuts with a torque setting of 3.5 Nm.

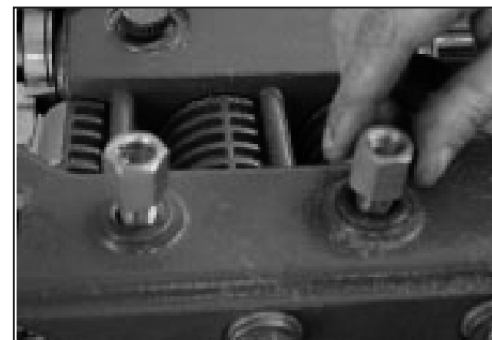

9. Now tighten all the other nuts simultaneously until the whole unit is tight and compact.



6 - Maintenance

Adjusting the 3-way valve

The 3-way valve can be adjusted if it is too tight or too loose (liquid loss). It is correctly adjusted when the valve handle can be turned using one hand only.

To ease operation clean the mating faces between ball (B) and the seat (A) of the valve.

Grease the valve every time you dismantle it for cleaning. This will extend the service life of ball and seat.

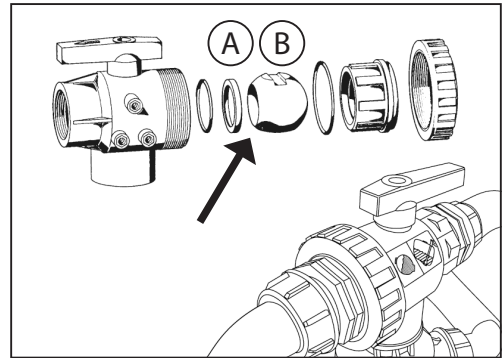

Replacing the driveshaft protector guard

1. Remove the screw (A), cap (B) and grease nipple (C): Twist the cover a quarter of a turn and pull it back.
2. Remove the synthetic bearings and the protection guard.
3. Remove the inner bush from the protection guard.
4. Re-assemble in the reverse order, using new parts if necessary. Remember to assemble the chains again.
5. Grease the bearings.



ATTENTION! Only use original HARDI parts to repair the driveshaft.

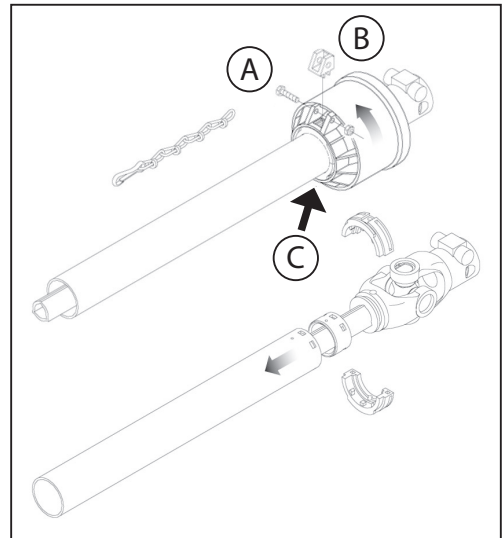

Replacing the driveshaft crossheads

1. Remove the protection guard as described previously.
2. Remove the Seeger rings.
3. Press the cross journals to one side (use a hammer and mandrel if necessary).
4. Remove the cross journal bearings and then remove the cross journal.
5. Remove the bearings from the new cross journal carefully and then install it. Before fitting the bearings again, check that the unit is assembled correctly. Protect the new bearings from dirt and dust.

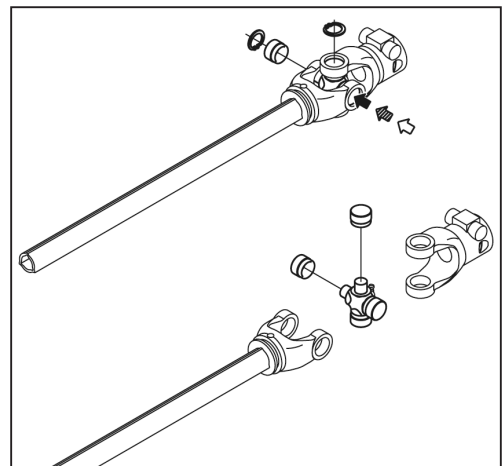

6 - Maintenance

Replacing the seal on the drain valve

If the drain valve leaks, the seal and the seat can be replaced as follows:

1. Make sure that the tank is empty and clean.
2. The valve must be closed and the lever loose.
3. Remove the U-clip A and pull the connection part B. Now the whole valve can be removed.
4. Check the condition and wear of the cord and the valve C, replace the seal D and reassemble.
5. Grease all o-rings F before assembling.
6. Fit the U-clip A again.



DANGER! Do not enter the tank – the parts can be replaced from outside the tank!



WARNING! Use a protective face mask when disassembling the drain valve!

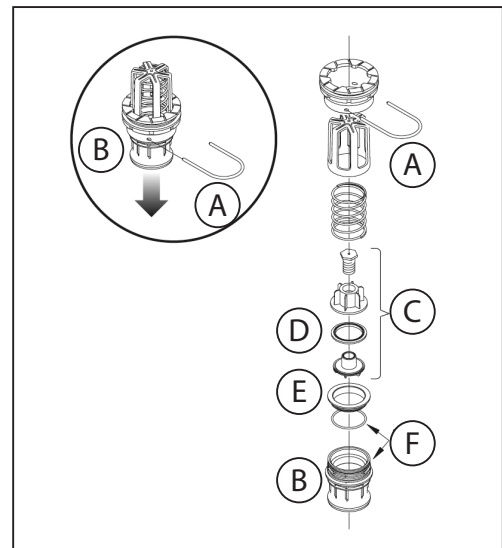

Storing the mistblower at the end of the season

When the spraying season is over, you should devote some extra time on the machine before storing it. If any chemical residues are left on the mistblower for a long period, it can reduce the service life of the components. To keep the mistblower intact and protect the components, you should perform the tasks as part of an off-season storage programme.

1. Clean the mistblower completely inside and out, as described in 'Cleaning the mistblower'. Make sure that all the valves, hoses and auxiliary equipment have been washed with detergent and rinsed with clean water afterwards, to ensure that no traces of chemical products are left on the mistblower.
2. Replace the o-rings and repair any possible leaks.
3. Empty the mistblower completely and let the pump work for five minutes. Open all the valves to drain as much water as possible from the circuit.
4. Pour approximately 50 litres Glycol / anti-freeze mixture in the tank, in order to lubricate diaphragms, valves etc. to prevent it from drying up, and be affected from that. (1/3 anti-freeze and 2/3 water).
Alternatively to anti-freeze, products like sun flower cooking oil can as well be used, but Glycol / anti-freeze liquid is better.
5. Start the pump and operate the controls of the 3-way valves, operating unit, etc. so that the anti-freeze is distributed throughout the entire circuit. Open the main ON/OFF valve and the distribution valves so that the anti-freeze is delivered through the nozzles also. The anti-freeze prevents the o-rings, seals, diaphragms, etc. from drying out.
6. Lubricate all the lubrication points according to the lubrication scheme. Disregard the normal lubrication intervals in this case.
7. When the mistblower is dry, remove the rust from any possible scratches or marks in the paint, and touch up the paintwork.
8. Remove the pressure gauge and store it a vertical position in a frost-free location.
9. Apply a thin layer of anti-corrosion oil (e.g. SHELL ENSIS FLUID, CASTROL RUSTILLO or similar) to all metal parts. Do not apply to hoses or rubber parts. See page of lubrication products.
10. All the electric plugs and sockets must be kept in plastic bags to protect them from damp, dirt and rust.
11. Remove the control box from the tractor (if fitted), and store it in a clean, dry place (in-house).
12. To protect the mistblower against dust, it can be covered with a tarpaulin. Make sure that it is ventilated to prevent condensation.

6 - Maintenance

Preparing the machine for use after storage

After storage, the machine should be prepared for safely starting work at the beginning of the season. To start up the machine correctly, proceed as follows:

1. Remove the tarpaulin protecting the machine if there is one.
2. Fit the pressure gauge again. Replace the old Teflon tape.
3. Connect the equipment to the tractor, including electric wires and hydraulic cables.
4. Check the brake.
5. Empty the tank of any remaining anti-freeze.
6. Rinse out the entire fluid circuit with clean water.
7. Fill the tank with clean water and check all functions.

Operational problems

General information

In almost all breakdowns, the same factors always seem to be present:

1. Small cracks or air leaks in suction side reduce the pump's capacity or stop suction completely.
2. A blocked suction filter causes the pump not to suck properly.
3. Clogged pressure filters cause pressure to rise on the pressure gauge but to fall at the nozzles.
4. Foreign bodies in the valves can cause the valve to not close completely. This reduces the pump's performance.
5. Poorly re-assembled pumps, especially diaphragm housings, cause the pump to suck air and hence, reduce or decrease the pump suction.
6. Hydraulic components that are contaminated with dirt result in rapid wear to the hydraulic system.

Therefore ALWAYS check that:

1. Suction, pressure and nozzle filters are clean.
2. Hoses have no leaks or cracks, especially the suction hoses.
3. Gaskets and o-rings are in good condition.
4. Pressure gauge marks the correct indication. Correct dosage depends on its accuracy.
5. Operating unit is in good working order. Use clean water to check it.
6. Hydraulic components are maintained clean.

7 - Troubleshooting

Fluid circuit

FAULT	PROBABLE CAUSE	POSSIBLE SOLUTION
On activating, the system doesn't spray	Air in the suction line.	Check the suction filter o-ring. Check the suction tube and fittings. Check the assembly of the pump crankcase covers and diaphragms.
	Air in the system.	Prime the pump by filling the hose with water
	Suction or pressure filters blocked.	Clean the filters Check the suction fitting and make sure that it is not too close to the outlet on the tank floor.
Loss of pressure	Incorrect assembly	The safety valve's spring is damaged. The suction fitting is blocked The suction filter is clogged
	Pump valves clogged or worn	Check for obstructions and wear
	Defective pressure gauge	Check for dirt in the intake
Pressure jumps	Filters clogged	Clean the filters. Clean with clean water. If powdered product is being used, check that agitation is on.
	Worn nozzles	Check that the air flow does not exceed 10%.
	Tank suction clogged	Check the suction tube
	Air suction	Reduce revolutions in the PTO
Increase in pressure	Pressure filters blocked	Clean the filters
Foam formed	Air in the circuit	Check the o-rings, gaskets, hoses and suction fittings
	Excessive agitation	Reduce revolutions in the PTO Check the voltage of the safety valve of the self-cleaning filter Make sure that there is return to the tank Use anti-foaming agent
Leak of pump liquid	Diaphragms damaged	Replace
The operating unit does not work	Fuse blown	Check the limit switches. Oil with lubricant if the limit switch does not make proper contact
	Incorrect polarity	Control box: Red - pos (+) Black - neg (-). Solenoid valves: Brown - pos (+). Blue - neg. (-).
	The valves do not close correctly.	Check for obstructions in the valves Check the limit switches
	No power	Incorrect polarity. Brown is pos. (+), Blue is neg. (-) Check the electric board Check that the fuse box makes contact with the bracket.

7 - Troubleshooting

Blower unit

FAULT	PROBABLE CAUSE	POSSIBLE SOLUTION
Excessive noise or vibrations in the blower unit	The fan is incorrectly counterbalanced	Balance the fan again
	The nuts that hold the air kit are loose.	Tighten the nuts.
	The clutch pads are broken or worn.	Change the pads and the clutch springs or replace the clutch for a new one
	Stiff tank transmission shaft	See annual maintenance Clean and oils shaft
Vibrations or noises in the gearbox	The gear is not properly engaged.	Move the gear lever to the correct position
	Worn gears	Replace the gears
	Oil level below minimum	Fill to the correct level and check for possible internal damage

7 - Troubleshooting

Electrical problems

Emergency function – Fluid circuit

In the event of power fault, the CB operating unit can be used manually. First disconnect the wire from the control box. Then manually turn the green throttle valve on each electric motor to open or close the valve.

The problem may result from a blown control box fuse.

8 - Technical specifications

Axial dimensions and weight

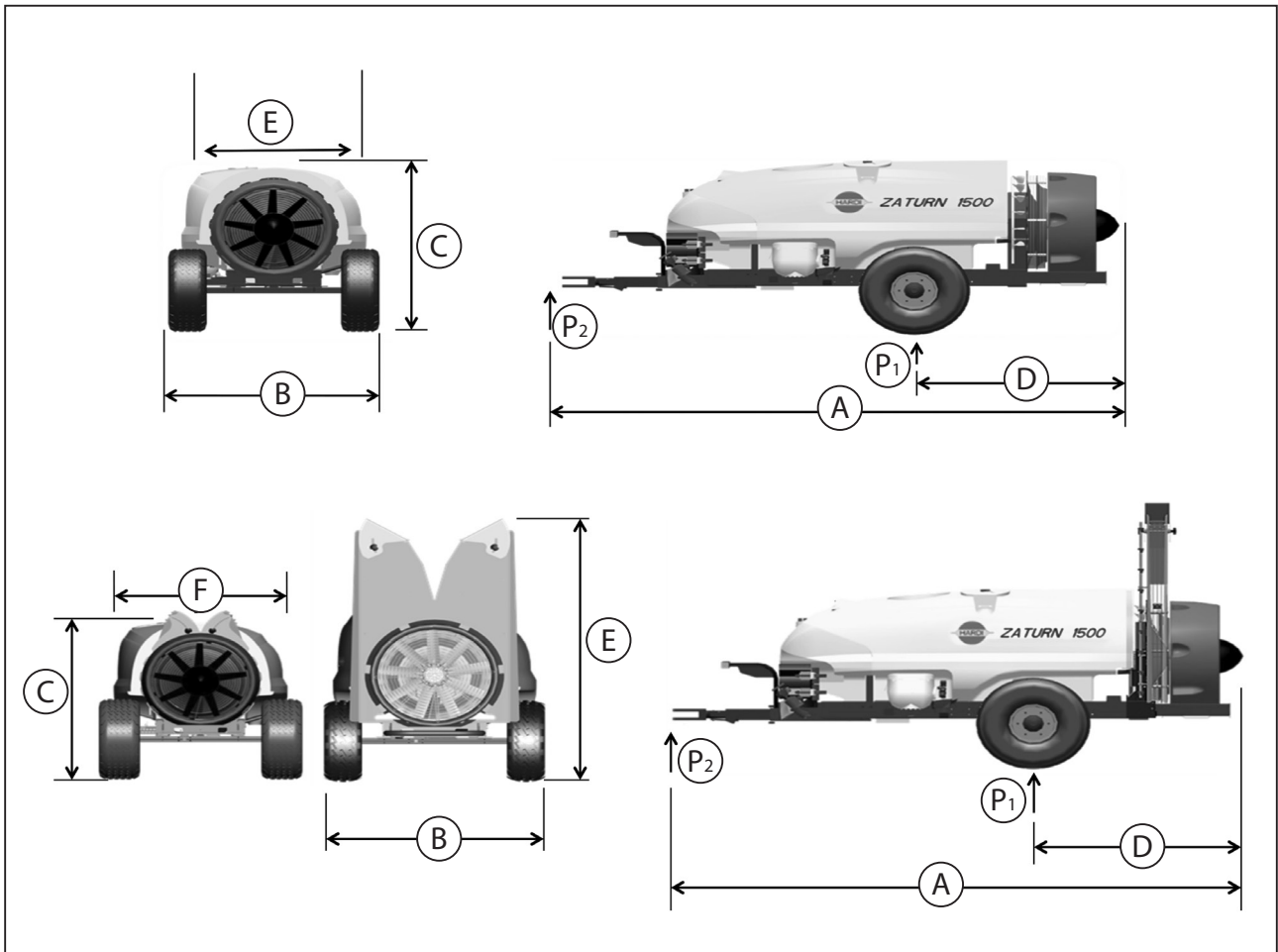

Zatur Compact

	A	B	C	D	E	F	P (Kg.)	P1 (Kg.)	P2 (Kg.)
800	3050-3550	1100-1550	1550	1000	2300	950	690	620	70
1000	3250-3550	1100-1550	1600	1000	2300	950	720	648	72
1300	3250-3550	1100-1550	1600	1000	2300	1200	740	658	82

8 - Technical specifications

Zaturn Plus AG

	A	B	C	D	E	P (Kg.)	P1 (Kg.)	P2 (Kg.)
1000	3386-3745	1450-2100	1455	650-1250	1200	695	625	70
1500	3596-4339	1550-2100	1550	650-1410	1350	845	791	54
2000	3995-4738	1550-2100	1550	650-1550	1500	905	847	58
3000	4095-4838	1550-2100	1800	650-1550	1680	1020	930	90

Zaturn plus AG with deflectors

	A	B	C	D	E	F	P (Kg.)	P1 (Kg.)	P2 (Kg.)
1000	3386-3745	1450-2100	1455	650-1250	2300	1200	795	715	80
1500	3596-4339	1550-2100	1550	650-1410	2300	1350	940	880	60
2000	3995-4738	1550-2100	1550	650-1550	2400	1500	1025	959	66
3000	4095-4838	1550-2100	1800	650-1550	2630	1680	1140	1039	101

Jupiter SF

	A	B	C	D	E	P (Kg.)	P1 (Kg.)	P2 (Kg.)
1500	3596-4339	1550-2100	1550	650-1410	1350	845	791	54
2000	3995-4738	1550-2100	1550	650-1550	1500	905	847	58
3000	4095-4838	1550-2100	1800	650-1550	1680	1020	930	90

Jupiter SF with deflector

	A	B	C	D	E	F	P (Kg.)	P1 (Kg.)	P2 (Kg.)
1500	3596-4339	1550-2100	1550	650-1410	2300	1350	940	880	60
2000	3995-4738	1550-2100	1550	650-1550	2400	1500	1025	959	66
3000	4095-4838	1550-2100	1800	650-1550	2630	1680	1140	1039	101

Mercury SF

	A	B	C	D	E	P (Kg.)	P1 (Kg.)	P2 (Kg.)
2300	4345-5088	1515-2350	1600-2630	1840-2225	1400	1040	936	104
3000	4515-5258	1700-2200	1810-1880	2030-2310	1650	1050-1250	945-1125	105-125
4000	4515-5258	1700-2200	1960-2030	2030-2310	1650	1380-1580	1242-1422	124-142

Mercury SF with deflector

	A	B	C	D	E	P (Kg.)	P1 (Kg.)	P2 (Kg.)
2300	4435-5158	1515-2500	2415-3450	2035-2315	1400	1140-1725	1026-1552	144-172.5
3000	4605-5348	1700-2500	2430-2920	2120-2400	1650	1100-1300	990-1170	110-130
4000	4605-5348	1700-2500	2430-2920	2120-2400	1650	1500-1700	1350-1530	135-153

8 - Technical specifications

Dimensions

Zenit Axial

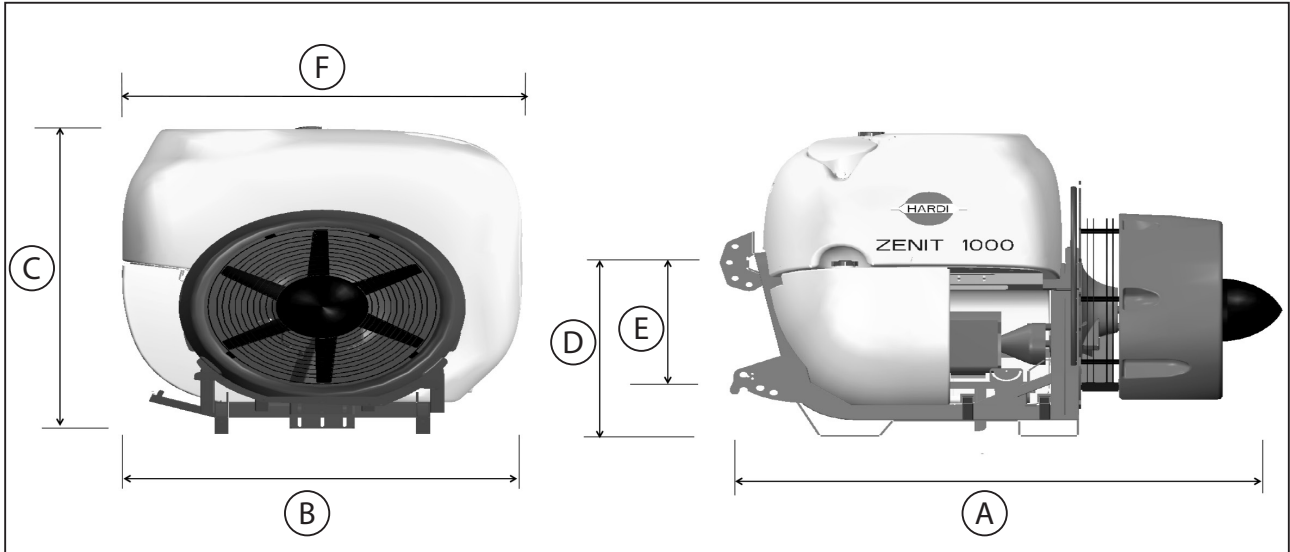

	A	B	C	D	E	F	P (Kg)
400	1542-1798	1000	1274	741	513	981	365
600	1542-1798	1200	1350	741	513	1200	372
1200	1880-2013	1615	1708	926	678	1430	450

Zenit Liner

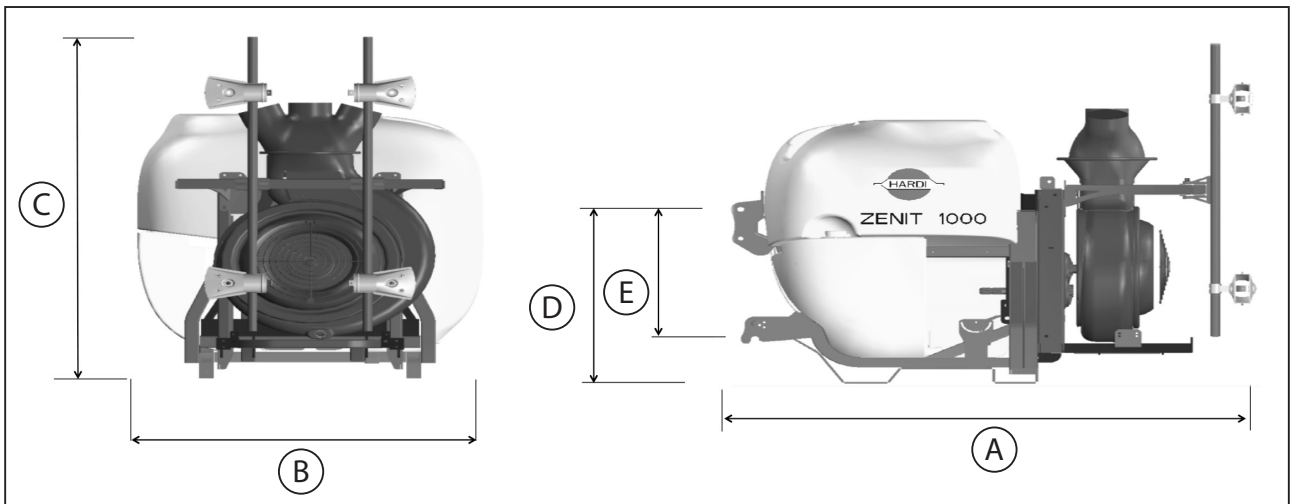

	A	B	C	D	E	P (Kg)
400	2000	2050	2300	892	663	365
600	2000	2050	2300	892	663	372
1200	2215	2050	2390	926	678	450

8 - Technical specifications

Turbines dimensions and weight

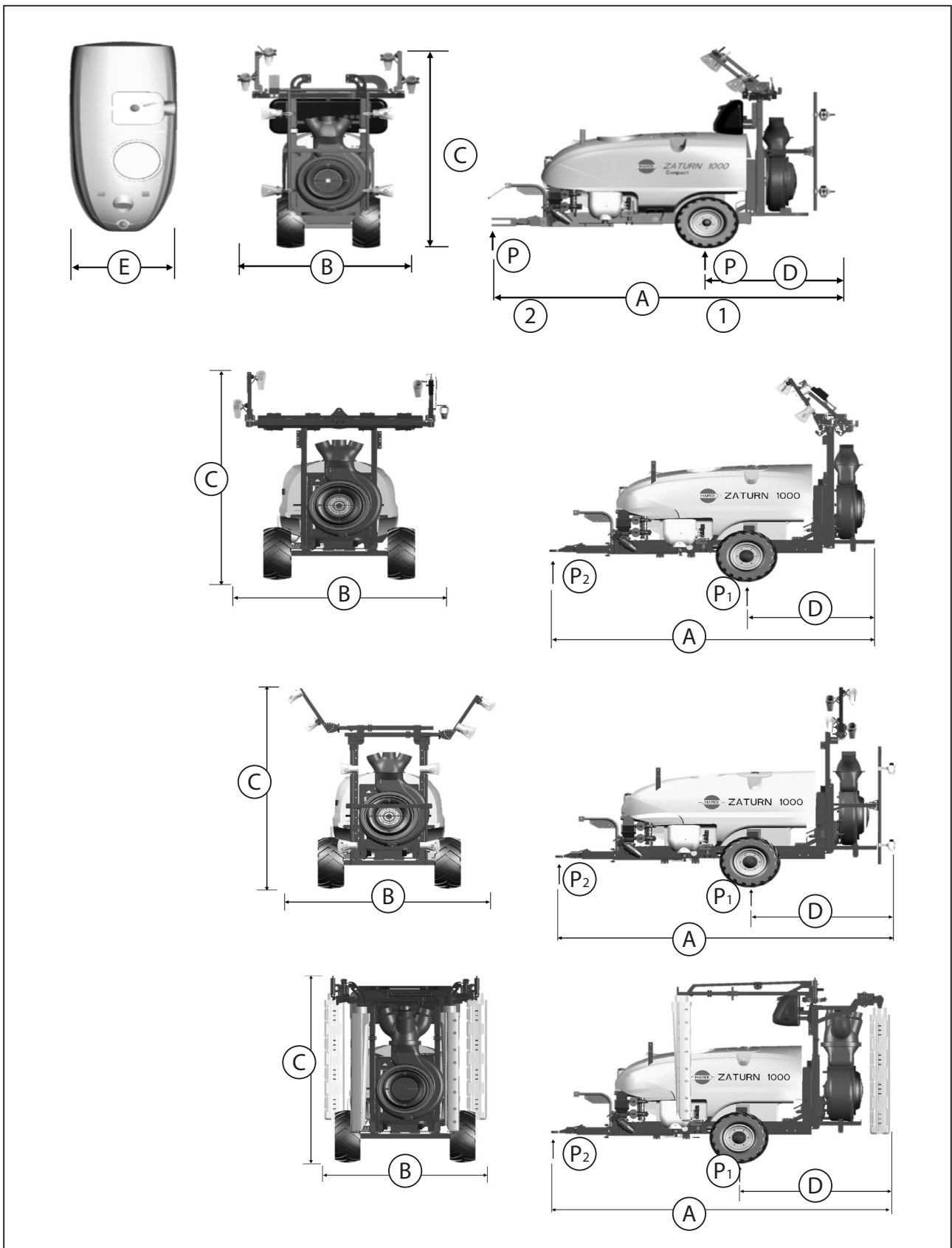

8 - Technical specifications

Zaturn Compact Liner

	A	B	C	D	E	P (Kg.)	P1 (Kg.)	P2 (Kg.)
600	2850-3150	1100-1550	1550	800	950	825	750	75
800	3050-3350	1100-1550	1550	1000	950	855	770	85
1000	3250-3550	1100-1550	1600	1000	950	915	813	102
1300	3250-3550	1100-1550	1600	1200	1200	940	828	112

Zaturn Plus Atlas

	A	B	C	D	E	P (Kg.)	P1 (Kg.)	P2 (Kg.)
1000	3386-3745	2300	2900	920 - 1860	1200	1150	987	163
1500	3596-4339	2300	2900	920 - 1860	1350	1300	1177	123
2000	3995-4740	2300	2900	920 - 1860	1500	1470	1420	50
3000	4095-4840	2300	2900	920 - 1860	1680	1475	1321	154

Zaturn Plus Boxer

	A	B	C	D	E	P (Kg.)	P1 (Kg.)	P2 (Kg.)
1000	3386-3745	2300	2900	920 - 1860	1200	1150	987	163
1500	3596-4339	2300	2900	920 - 1860	1350	1300	1177	123
2000	3995-4740	2300	2900	920 - 1860	1500	1470	1420	50
3000	4095-4840	2300	2900	920 - 1860	1680	1475	1321	154

Zaturn Plus Cronos

	A	B	C	D	E	P (Kg.)	P1 (Kg.)	P2 (Kg.)
1000	3386-3745	2300	2900	1170 - 2070	1200	1150	987	163
1500	3596-4339	2300	2900	1170 - 2070	1350	1300	1177	123
2000	3995-4740	2300	2900	1170 - 2070	1500	1470	1420	50
3000	4095-4840	2300	2900	1170 - 2070	1680	1475	1321	154

8 - Technical specifications

Conversion factors (SI to Imperial)

All units used in this instruction book are SI. In some cases, imperial units are used. Use these factors to convert between SI and Imperial units:

	SI unit	Imperial unit	Factor
Weight	kg	lb	x 2.205
Surface area	ha	acres	x 2.471
Length	cm	in	x 0.394
	m	ft	x 3.281
	m	yd	x 1.094
	km	mile	x 0.621
Speed	km/h	mile/h	x 0.621
	km/h	m/s	x 0.277
Volume/Surface area	l/ha	gal/acre	x 0.089
Volume	ml	fl. oz	x 0.0352
Torque	l	Imp. pt.	x 0.568
	l	gal	x 0.22
Pressure	bar	lb./inv (p.s.i.)	x 14.504
Temperature	°C	°F	(°C x 1.8) + 32
Power	kW	hp	x 1.341
Torque power	Nm	lb.ft.	x 0.74

8 - Technical specifications

Specifications

Pump model 363/7

HARDI		HARDI INTERNATIONAL A/S TAASTRUP DENMARK	
Type 363/7	 r/min.max. 700		
No.			
r/min.	l/min.	bar	kW
540	140	0	1.6
540	127	10	3.4
		max.20	

Pump model 321/10

HARDI		HARDI INTERNATIONAL A/S TAASTRUP DENMARK	
Type 321/10	 r/min.max. 700		
No.			
r/min.	l/min.	bar	kW
540	70	0	0.6
540	62	10	1.2
		max.20	

Filters and nozzles

Filter mesh width

30 mesh: 0.58 mm

50 mesh: 0.30 mm

80 mesh: 0.18 mm

100 mesh: 0.15 mm

Temperature and pressure range

Working temperature range: 2° – 40° C. (36°F – 104°F)

Pressure that activates the safety valve: 20 bar in HLC and 40 bar in HPC

Maximum pressure in the pressure valve: 20 bar in HLC and 40 bar in HPC

Maximum pressure in the suction valve: 7 bar

8 - Technical specifications

Materials and recycling

Disposing of the mistblower

When the mistblower has reached the end of its useful working life, it must be thoroughly cleaned. The tank, hoses and synthetic fittings can be incinerated in an authorised disposal depot. The metal parts can be scrapped. Always comply with existing local regulations.

Materials used:

Tank: MDPE

Hoses: EPDM

Valves: mainly PA+FG.

Fittings: PA+FG.

A

Adjustment 55
Air flow for axial air kits 23
Air kit 98
Anti-corrosive 85
Anticorrosive 80
Anti-freeze liquid 82
Apply on outer surfaces 84
Appropriate detergent 81
ATLAS boom 31
Axial blower units 21

B

BOXER boom 31
Break away clutch 33, 54
Bypass valve 73

C

Calibration 58, 100
CANNON 75
Cannons 58
Centrifugal Blower Units 26
Chemical inductor 20
Circuit 80
Circuit Diagram 16
Cleaning 80
Cleaning detergent 82
Clean water tank 66
Clutch 93
Clutch (All blower types) 28
Conserve liquid circuit 82, 84
Conserves all synthetic part 80
Control boxes 73
Convert 56
CRONOS 52
CRONOS boom 32

D

Deactivating agent 81
Deflector 47, 48
Diaphragm pump 14, 46
Diaphragms 95, 99
Display 44, 45
Drain valve 66, 105
Driveshaft 104
Drying out 105

E

Electrical connections 43

F

Filling the sprayer 64
Fluid Box 44, 45
Fold dépliage 74

G

Gear 60
Gearbox 28, 92
Glycol 80
Grease 85
GV 53

H

Hydraulic box 44, 45
Hydraulic connections 42
Hydraulic fold 54

I

Identification plate 13
IRIS system 35

J

Joystick 79
Joystick S selector 74

L

LINER boom 30

M

Manifold system 15, 66

P

Power supply 71
Pressure equalisation 72
Pressure regulation 72
Prevents 105
PTO 94
Pump 100

R

Rate controller 44, 45, 77, 78
RIDER 52
Rinsing tank 65, 70

S

Safety information 60
Safety valve 18, 80
Selecting the gear 61
Storing 105
Strictly forbidden 24
Suction filter 46
Suitable lubricants 80

T

The liquid circuit 14
Transport bracket 62
Turbines 26, 27
TurboFiller 20, 67

U

Use of the mistblower 12

V

VARIA 53
Vegetation sensor 76

W

Washing soda 81
While moving the Sprayer 62
Working hours 92

Spare parts

For updated information on spare parts, visit www.agroparts.com.
Here you can access information on all spare parts. Registration is free.



ILEMO HARDI S.A.U.

SPAIN - www.hardi.es

