

REVISIONS				
ZONE	REV.	DESCRIPTION	DATE	CHECKED BY

ITEM	PART No.	DESCRIPTION	Default/QTY.
1	ZS298	FLEXI ARM AND STUB (600KG)	1
2	UF128	BOLT, 3/8 X 1, HI TENSILE	6
3	UF029	NUT, 3/8 BSW, NYLOC, BZP	6
4	MW005	F100 HUB WITH 9/16" STUDS	1
5	ST055	R-Flex FS6 BODY (600kg)	1

hub - 5 lug on 5 1/2" pattern
 9/16" stud diameter
 inner seal CR14974 (204013)
 inner race LM67010
 inner bearing LM67048
 outer race LM11910
 outer bearing LM11949
 2.72" dust cap O.D.

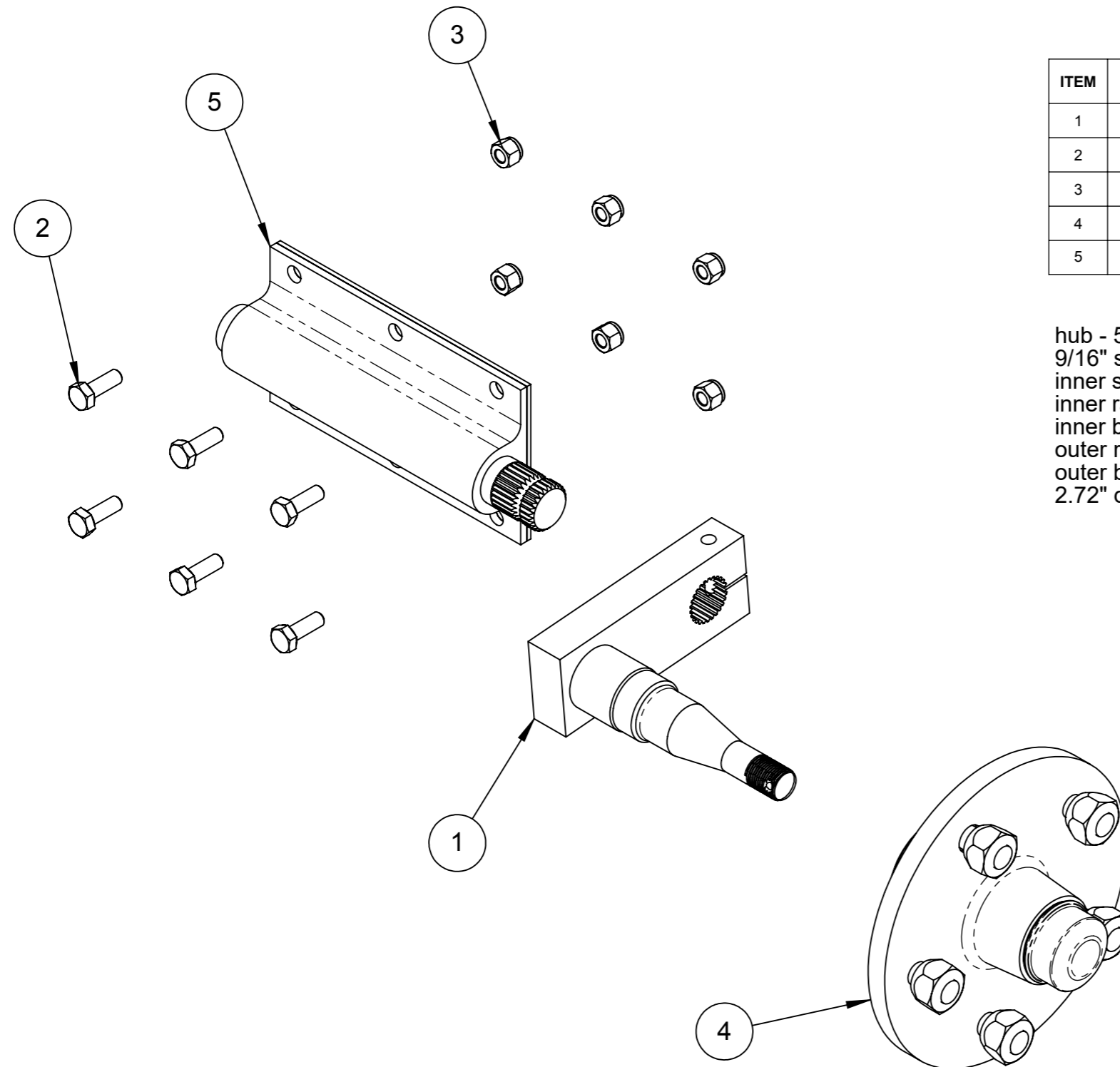

UNSPECIFIED TOLERANCES: 0.....±0.5 0.0.....±0.1 0.00.....±0.02	DEBUR AND BREAK SHARP EDGES DIMENSIONS IN MILLIMETERS UNLESS OTHERWISE STATED DO NOT SCALE
THIRD ANGLE PROJECTION	
DRAWN BY: M BOTFIELD	DATE: 22/03/2017
MATERIAL:	
FINISH:	
WEIGHT: 5525.3	

MICRON GROUP
 BROMYARD INDUSTRIAL ESTATE, BROMYARD, HEREFORDSHIRE, HR7 4HS
 TEL: 01885 482397 FAX:01885 483043

TITLE: HD SUSPENSION 600KG WITH HUB AND FIXINGS	
PART NO. ZS299	REVISION A
PROJECT SPRAYDOME ADJUSTABLE	
SCALE: 1:3	SHEET 1 OF 1