

REVISIONS				
ZONE	REV.	DESCRIPTION	DATE	CHECKED BY

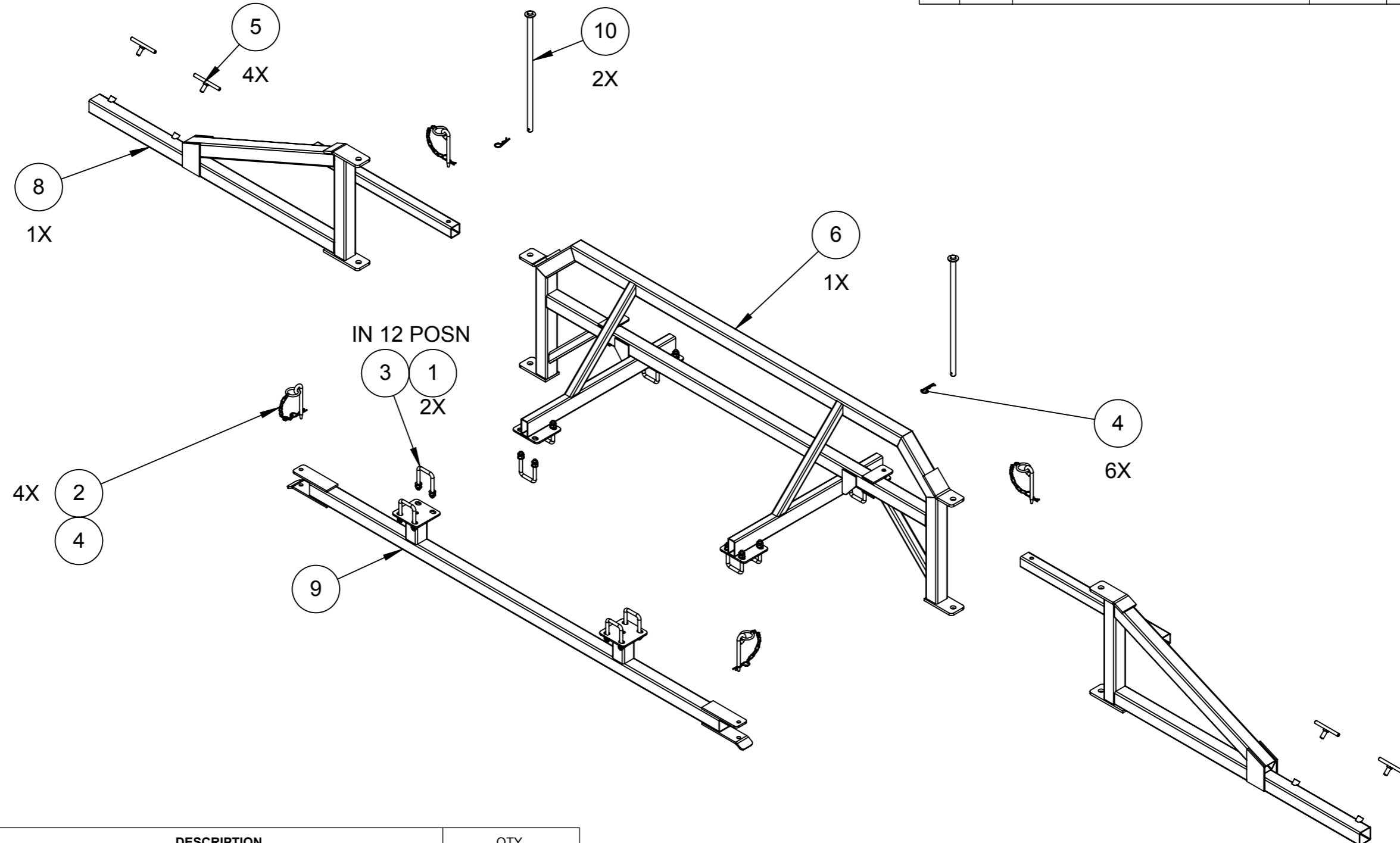

8	PART No.	DESCRIPTION	QTY.
1	5973	WASHER, M10 FLAT, S/S	24
2	7739	COTTER PIN & CHAIN, 10x109 LONG UNDRILLED	4
3	11261	C BOLT, M10 X 80, SS, FOR 50 X 50 RHS	12
4	GS076	R-PIN ϕ 3mm	6
5	ZS433	CLAMP BOLT 1/2" BSW	4
6	ZS811	FRAME, CENTRE, TRAILER BOOM	1
7	ZS812	ARM, TRAILER BOOM, LH	1
8	ZS813	ARM, TRAILER BOOM, RH	1
9	ZS814	BRACKET, BOOM SUPPORT	1
10	ZS815	TRAILER BOOM HINGE PIN	2

UNSPECIFIED TOLERANCES: 0..... \pm 0.5 0.0..... \pm 0.1 0.00..... \pm 0.02	DEBUR AND BREAK SHARP EDGES DIMENSIONS IN MILLIMETERS UNLESS OTHERWISE STATED DO NOT SCALE
THIRD ANGLE PROJECTION	
DRAWN BY: M BOTFIELD	DATE: 11/07/2019
MATERIAL:	
FINISH:	
WEIGHT: 62454.2	

MICRON GROUP
BROMYARD INDUSTRIAL ESTATE, BROMYARD, HEREFORDSHIRE, HR7 4HS
TEL: 01885 482397 FAX: 01885 483043

TITLE: **TRAILER BOOM FRAMES FOR 200L ORCHARD TRAILER**

PART NO. AA920	REVISION 1
PROJECT ENVIROMIST	

SCALE: 1:14 SIZE: A3 SHEET 1 OF 1