

TABLE OF CONTENTS

Introduction	1
Set-Up Instructions	1
Assembly Instructions	2-11
Drive Line Safety Tips	12
Drive-Line Safety Checklist	12
Drive-Line Specifications	12
Hazard Reduction	13
Guarding	13
Warnings and Instructions	14
Safety Instructions	15
Machine Checklist	16
Machine Operation	16-17
Lubrication Frequencies and Locations	18
Preventative Maintenance	18
Troubleshooting	19
Drive-Line Fitting Adjustments	20-21
Knife Changing / Adjusting Instructions	22-23
Flywheel Knife Sharpening Instructions	24
Hydraulic Filter Changing Instructions	24
Clearing an Object From the Flywheel Housing	25
Drive Belt Changing / Adjusting	26
Warranty	27
Appendix (Tech Drawings)	i-xvi

INTRODUCTION

CONGRATULATIONS! You have just purchased the **WoodMaxx™ WM-Series Wood Chipper**, the strongest, safest and the most compact PTO wood chipper available. We have compiled this owner's manual to help you understand and appreciate your chipper. By taking a few minutes to read this manual and understand the maintenance instructions, it will give you better performance and extend the life of your chipper. Read the manual before operating the chipper.

SET-UP INSTRUCTIONS

- Your chipper does need to be set up prior to installation. It arrives in a steel crate that can be dismantled in minutes. See Assembly Instructions The in-feed bin and discharge chute are shipped with the unit and are located in the bottom of the steel crate.
- Visually inspect the in-feed bin, and the fly wheel before attaching to tractor, and applying power to ensure that nothing is in the chipper head. If the chipper deflector or any of the guards have been removed for shipping, be sure to replace them properly before use.
- The PTO (Drive-Line) is also shipped with the unit and is located in the bottom of the steel crate.
- When mounting, keep the chipper as close to the tractor as possible.
- Important- Make sure that the PTO shaft is sized properly
- While in use, keep the PTO shaft as straight as possible. No more than 15 degrees from level is acceptable.
- Do not operate the chipper without the chip deflectors, and or drive belt cover properly in place.
- Read and understand all assembly instructions prior to assembly.

ASSEMBLY INSTRUCTIONS

Before you get started there are a few tools you will need:

- 13mm Wrench (same as 1/2")
- Adjustable Wrench
- 16mm Wrench (same as 5/8)
- 19mm Wrench or Socket (same as 3/4")

Assembly Time 2.5 Hours

- Remove the plastic wrapping from the crate and inspect the chipper for any obvious shipping damage
- Remove and unwrap all of the chipper components that are packaged with the crate.
- Remove the cardboard box from the in-feed bin; this box contains the user's manual, the hardware packet, extra shear bolts, and any additional items you may have purchased such as extra chipper knives. [Fig. 1a].



- Open the hardware packet and organize the enclosed fasteners into separate piles.
- There is a picture of the hardware on pg. 4 of this manual that you can use as a guide to ensure that you use the correct hardware in the upcoming steps.
- Remove the four bolts that secure the top of the crate frame.
- Remove the top of the crate, and set it aside.
- Located on the bottom of the crate is a cross bar that secures the chipper to the frame. Loosen the two bolts that hold this bar in place, and drive the bar forward with a dead blow hammer. [Fig. 1b].

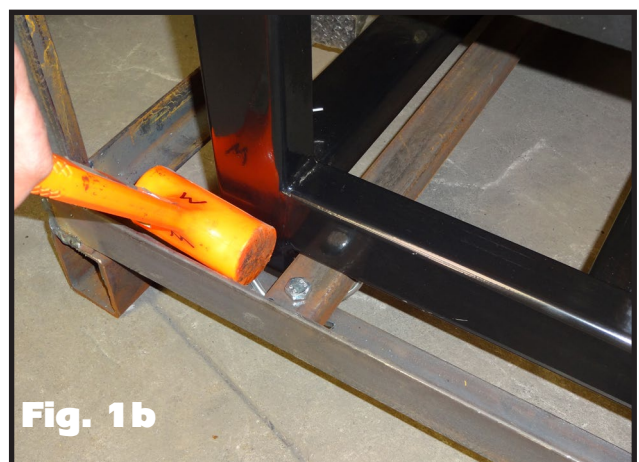

ASSEMBLY INSTRUCTIONS

- ✓ Locate the lift point on the top of the chipper. This is the balance point, and the only point the chipper should be lifted from.
- ✓ Using a chain or strap that is rated strong enough to lift the weight of the chipper, lift the chipper out of the crate. [Fig. 2]
- ✓ If you do not have a front end loader, attach the three point hitch of your tractor to the chipper to lift the chipper out of the crate.
- ✓ Measure the distance from the PTO spline of your tractor to the ground [Fig. 3]. Write down this measurement here _____. You will need it for the next step.
- ✓ While the chipper is raised in the air, attach the four adjustable base legs so that when the chipper is on the ground, the spline of the chipper is slightly lower than the spline of your tractor. [Fig. 4]. The shaft does not need to be perfectly horizontal, but it is recommended that the slope of the PTO shaft is no more than 15 degrees. [Fig. 5]

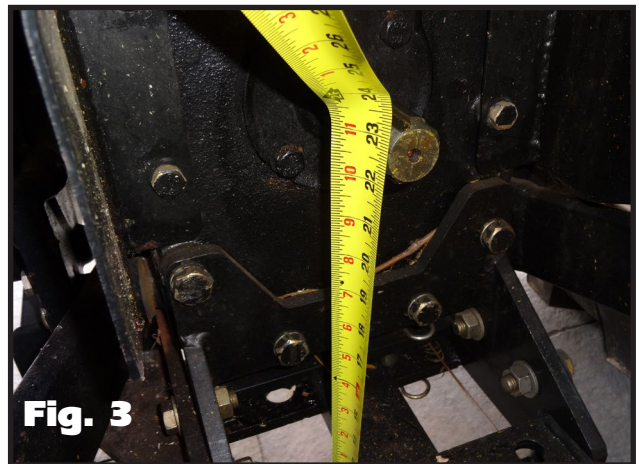
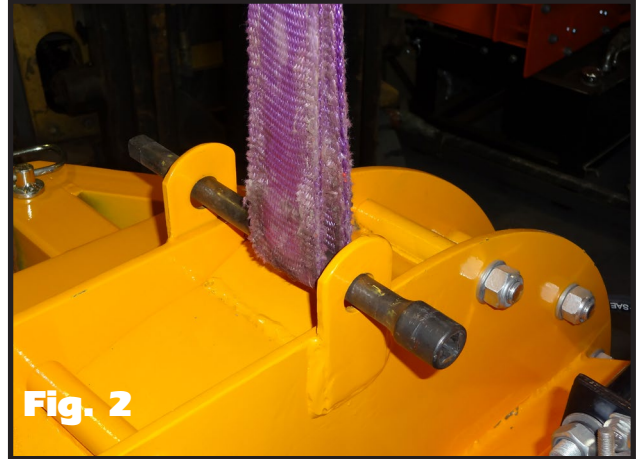

- ✓ At this time, carefully lower the chipper to the ground, and remove the chain or strap

ASSEMBLY INSTRUCTIONS

In-feed bin left side panel

In-feed bin right side panel (control valve side)

In-feed roller assist lever

In-feed bin bottom panel

Hardware box & accessories

In-feed bin top panel

Support leg

Adjustable base legs

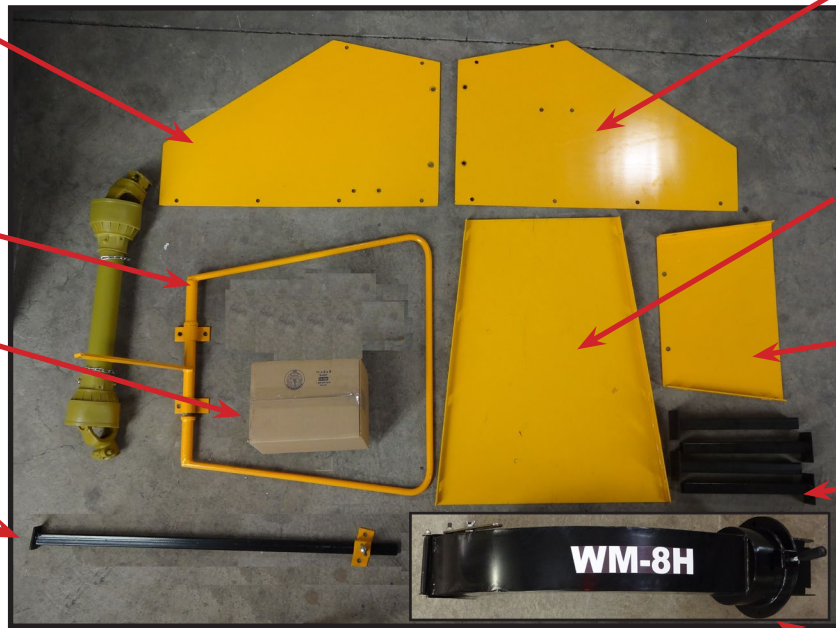

Discharge chute

(18) M10x-25mm

(2) CAT 1 Draw Pins

(4) M10x15

(1) Spring Removal Tool

(18) M10 Lock Nuts

(4) Lock Washers

(2) Bolts For Safety Bar

(8) Fender Washers

(1) 5/8"x4" Pin

(4) 2-Hole Straps

(2) 1/2"x4" Pins

(2) M8x60mm

(40) 10mm Washers

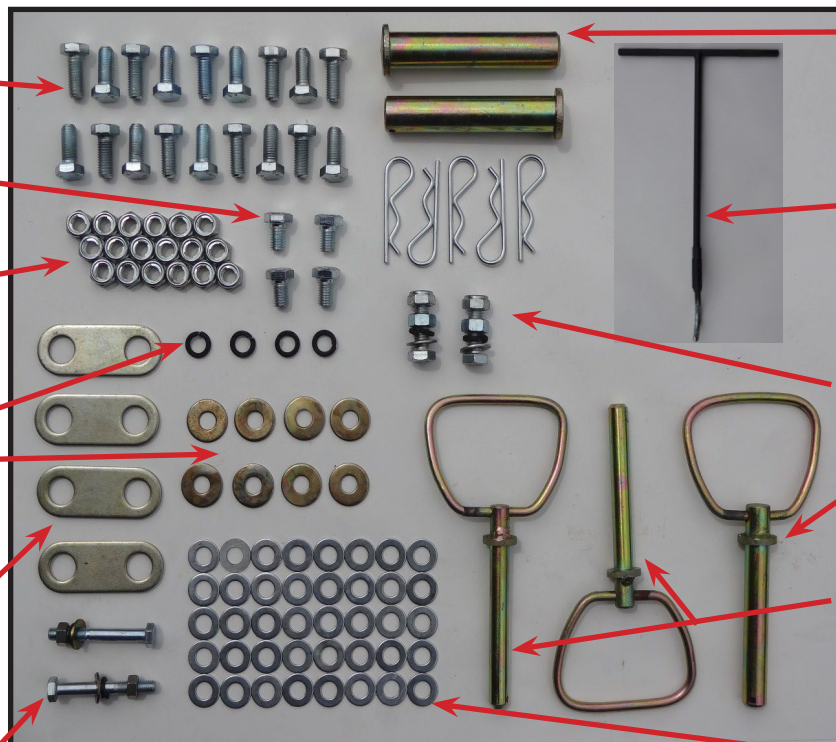

ASSEMBLY INSTRUCTIONS



Use Fender Washers Here

Outside mount

(bolt, fender washer)

Inside mount

(washer, lock nut)

[Above] View of proper assembly of in-feed bin using 2 hole straps. All other bolts are typically assembled as follows; bolt-washer-panel-washer-lock-nut



Fig. 6



Fig. 7



Fig. 8

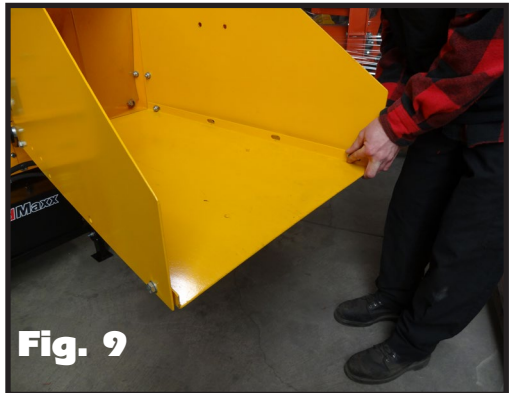

Fig. 9

- Attach the left panel of the in-feed bin using two of the 2-hole straps and two M10x-25mm bolts. The straps will bend when tightened down. This panel can be identified by the two small holes on the bottom of the panel where the fasteners for the support leg attach. [Fig. 6]
- Attach the right side panel in the same manner. This panel can be identified by the two fastener holes in the middle of the panel where the hydraulic control valve mounts. [Fig. 7]
- Attach the bottom panel of the in-feed bin, by first inserting the two M10x25 bolts through the side panels in the two holes closest to the feed roller. Do not tighten these bolts yet, and allow the panel to hang vertically. [Fig. 8]
- Raise the bottom panel in place and insert two M10x25 bolts through the side panel in the two holes closest to the end of the panel. [Fig. 9]
- Install the remaining four M10x25 bolts in the remaining four holes in the lower panel.

ASSEMBLY INSTRUCTIONS

- Before tightening the bolts, ensure that the lower panel is slightly higher than the in-feed bin. This will prevent material from hanging up where the two pieces join together. [Fig. 10]
- Attach the top panel of the in-feed bin by installing the two M10x25mm bolts in the two forward holes of the panel. [Fig. 11]
- Install the two M10x40mm bolts in the two holes closest to the opening. These bolts should be installed from the inside so that they point outward. [Fig. 12]. These bolts are used to connect the safety bar in an upcoming step.
- Attach the support leg with two M10x25 bolts. [Fig. 13]. Remember, the support leg should be in the down position during storage only. When the chipper is attached to the tractor, the support leg should be in the up position at all times.

Note: Although we choose to install the hardware with the bolts pointing into the in-feed bin, it is acceptable to point them outward to avoid the possibility of branches catching on the

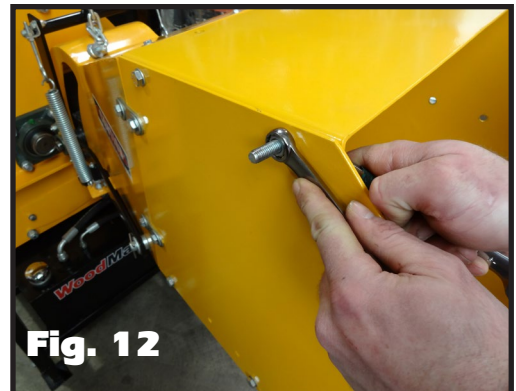
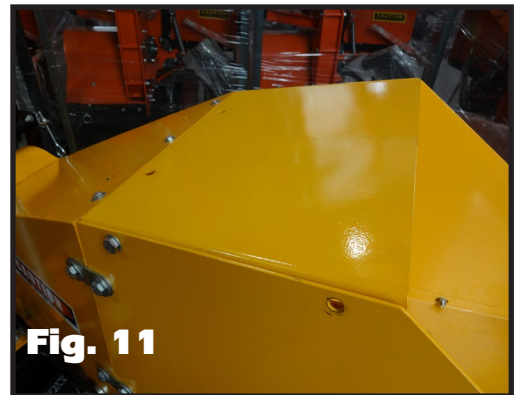

ASSEMBLY INSTRUCTIONS

- Attach the hydraulic control valve to the right side panel of the in-feed bin using two M8x60 bolts. [Fig. 14].
- Attach the upper feed roller assist lever using four M10x25mm bolts. [Fig. 15].
- Fasten the chain from the upper feed roller assembly to the feed roller assist lever. The hardware for this is found located on the end of the chain. [Fig. 16].
- Connect the safety bar to the two M10x40 bolts protruding from the top side of the in-feed bin. First, hook the control valve side of the safety bar over the bolt on the right side panel, then pull the opposite arm of the safety bar over the bolt on the left side panel. [Fig. 17, 18].

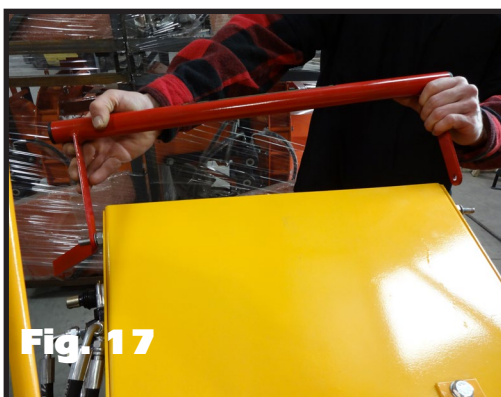

ASSEMBLY INSTRUCTIONS

- Thread an M10 locknut onto the bolt on either side, but do not tighten these nuts. This is a hinge point, and the safety bar must move freely. [Fig. 18].
- Connect the safety bar to the hydraulic control valve by removing the lever on the valve, aligning the slot on the safety bar to the valve, and reinstalling the lever. [Fig. 19, 20].
- Some hydraulic fittings are left slightly loose for shipping purposes, so at this time check and tighten them as needed.
- Affix the discharge chute to the chipper using four M10x15mm bolts along with the four 10mm lock washers that were included in the hardware packet. [Fig. 21].



Note: Please check to make sure all nuts and bolts on machine are tightened after you complete assembly, and before machine is first used. This step has not been done for you prior to shipment, except for the flywheel bolts and knife bolts.



Fig. 18



Fig. 19



Fig. 20



Fig. 21

ASSEMBLY INSTRUCTIONS

- Fill the hydraulic tank with 6-1/2 gallons of high quality hydraulic oil. There is a chart on page 18 that you can refer to determine the proper viscosity recommended for your region. Do not over fill the tank; there should be a 1" air space at the top of the tank.
- Connect the chipper to the 3 point hitch of your tractor [Fig. 23], or if you have one, using your category I quick hitch. [Fig. 24].



- Next you must measure to determine the proper length of the PTO shaft
- To do this, raise the chipper so that the spline of the chipper and that the spline of the tractor are horizontal with each other.
- Measure the distance from the end of the spline of your tractor to the end of the spline of the chipper. This is the Measured Shaft End Distance, or MSED. [Fig. 25].
- Now the shaft must be sized according to this measurement. Refer to the cart on the bottom of page 20 to determine if the shaft must be cut to size. If so, see the "PTO shaft cutting instructions" on page 21 .



ASSEMBLY INSTRUCTIONS

- After properly sizing the shaft, locate the three grease fittings on the shafts U-joints, and pump several shots of high quality grease into the fittings. [Fig. 26]. **NOTE: Check to ensure that the zerk (grease) fittings are screwed in tight. Occasionally, dried paint may cover the end of the zerk fitting on the PTO shaft. Remove this by scraping the paint off with a knife prior to attempting to pump grease into these fittings.**
- Attach the PTO shaft from the tractor to the chipper. Notice that one end of the shaft has a shear bolt, this end should be attached to the tractor. [Fig. 27]
- Prior to shipping the chipper to you, the following service has been done in our warehouse: the drive belts have been adjusted and tightened, the bearings on the chipper have been greased, USA made knives have been installed, adjusted, and the bolts were torqued to 40 ft. lbs.
- Before operating your chipper, you must first purge any air from the hydraulic system.
- First, locate the hydraulic flow valve (this valve is the in-line valve on the hydraulic line with a small dial). Turn the dial counter-clockwise, and ensure that the valve is fully opened. [Fig. 28]. This valve is used to increase or decrease the in-feed roller speed. Turn the dial counterclockwise to increase speed, and clockwise to decrease speed. Use slower speed for larger material, but for peak performance the valve should be kept open for optimal hydraulic flow and pressure.



Fig. 26



Fig. 27



Fig. 28

ASSEMBLY INSTRUCTIONS

- The hydraulic control valve has three detent positions. The center position is neutral. Pull back on the lever toward the hopper opening to engage the feed rollers, and push forward on the lever to reverse the feed rollers. At this time, leave the valve in the center position.
- Start your tractor's engine. While at idle, engage the power take off (PTO) of your tractor. Make sure that you are wearing protective safety gear at this time and that all bystanders are safely out of the way.
- Slowly increase the engine speed of your tractor until the PTO speed reaches 540 RPM. Usually there will be a mark on your tractor's tachometer that will indicate the necessary engine speed to achieve the required PTO speed of 540 RPM. [Fig. 29]



- Run the chipper with the hydraulic control valve in the center position for 2-3 minutes. Then move the lever into the remaining positions, and run it for an additional 2-3 minutes each. When you notice that the feed rollers change direction when the hydraulic valve is actuated, the system is purged. **NOTE: Occasionally when purging the hydraulic system, air bubbles (foaming) will develop in the lines. This is evident when, immediately after purging the system, the rollers do not run smoothly. To rectify this, let the chipper sit overnight. This will allow the bubble to settle out of the hydraulic fluid.**
- Disengage the tractor's power take off, and stop the engine. When the flywheel stops turning, recheck the hydraulic oil level. There should be a 1" air space at the top of the tank. If more oil is required, add it at this time.
- Setup is now complete. Please read and understand all operation instructions before using the chipper.



DRIVE LINE SAFETY TIPS

Agriculture and forestry are recognized as one of the most hazardous of occupations. Today's farmer spends long hours in close proximity to increasingly complex and powerful machinery.

To avoid accidents, everyone from the component supplier and the company who manufactures and assembles the machinery, to the dealers and ultimately the actual user, must keep safety in mind. The checklist below relates to the drive line of agricultural implements, general safety literature, and the standards published by the American Society of Agricultural Engineers.

DRIVE LINE SAFETY CHECKLIST

Drive-Line Specifications – The first step towards safe applications is to specify and test the drive-line so that it operates properly under expected field conditions.

1. Specify and test the proper size joints and telescoping members based upon the power required by the implement, speed of rotation, joints angles, shock loads, and expected life.
2. Test the hitch geometry to prevent the drive line from:
 - Extending beyond the recommended maximum length.
 - Bottoming out.
 - Reaching a position that allows universal joints to lock.
 - Exceeding the maximum allowable angle for constant velocity of the universal joints.

Information concerning these parameters may be found in all drive-line manufacturer's catalogs.

3. Specify and test telescoping members to allow the lowest possible thrust loads, considering the expected working conditions.
4. Specify and test torque limiters to control excessive shock loads.
5. Where necessary, specify and test overrunning clutches to prevent inertial loads from overpowering the tractor.

DRIVELINE SAFETY CHECKLIST

Hazard Reduction - The second step in specifying a safe drive-line application is to strive to eliminate as many hazards as possible

1. On drive-line with torque limiting or overrunning devices, specify that the device be positioned to the end of the drive-line by the implement.
2. For implement connections which require bolts or set screws, select and/or supply hardware which minimizes protrusions. Information concerning these parameters may be found in all drive-line manufacturer's catalogs.
3. For tractors PTO shaft connections, specify a safety type yoke (twist or slide collar) to minimize protrusions.
4. Provide a proper clearance zone for the operation of the drive-line, to avoid damaging the shielding components.

Some common areas of interference are:

- Three point linkage.
- Extended or eye loop hitch pins.
- Hydraulic hoses.

Guarding – For hazards which cannot be eliminated effectively, guarding must be provided whenever feasible.

The PTO master shield, integral drive-line shield, and implement input connection shield should provide an interactive guarding system.

1. Provide instructions by labels or manuals. The implement should be used only with the tractor's PTO master shield in place.
2. Specify and test an integral drive-line shield with end cones which overlap, but not interfere with the PTO master shield or implement input connection shield.
3. Provide an implement input connection shield to interact with the integral drive-line shield to provide guarding of the shaft coupling and any torque limiting devices installed on the drive-line.
4. Check that all routine maintenance of the drive-line can be done without removal of the shields.

DRIVELINE SAFETY CHECKLIST

Warnings and Instructions – Provide warnings and instructions for hazards associated with the machine. Provide instructions for proper maintenance and repair.

1. Provide labels on the unit to advise the user of proper hitch dimensions and maximum safe operating speed.
2. Check that proper danger labels are supplied with the drive-line concerning these parameters may be found in all drive-line manufacturer's catalogs.
3. Provide easy-to-understand instructions for proper drive-line operation, maintenance, and repair in the operator's manual.
4. Advise against the use of PTO adapters which may defeat the purpose of the tractor's master shield and adversely affect the performance of the drive-line.
5. Advise the user of locations of genuine original equipment spare parts.

Further information about drive-line specifications and safety may be obtained from your drive-line supplier and the following ASME standards and engineering practices:

S203 – Rear power take-off for agricultural tractors

S205 – Power take-off definitions and terminology for agricultural tractor

S207 – Operating requirements for tractors and power take-off driven equipment implements

S318 – Safety for agricultural equipment

S331 – Implement power take-off drive-line specifications

S333 – Agricultural tractor auxiliary power take-off drives

S350 – Safety alert symbol for agricultural equipment

S441 – Safety signs

S493 – Guarding for agricultural equipment

EP363 – Technical publications for agricultural equipment

Other standards may apply for particular types of implements. All drive-line manufacturers strive to produce a safe product. Drive-lines, like most other components must be used properly, including the use of proper tractor master shields and implement input connection shields. Please contact us if you have any questions about your drive-line applications.

SAFETY INSTRUCTIONS

Do not attempt to operate the chipper until you have read and understand the owner's manual.

Keep the decals in place and in good repair. We will furnish new decals upon request.

It is NOT recommended to operate the chipper in temperatures below freezing. Hardened steel (as used on knives) can become brittle in temperatures below freezing and may result in breakage.

Always keep the guards and chip deflector installed properly while operating the chipper.

Never leave the chipper running unattended.

Do not attempt alterations, repairs, or adjustments while the flywheel is turning. Always disconnect the PTO, stop the tractor's motor, and put the keys in your pocket prior to attempting any alterations, repairs or adjustments.

Keep hands, feet, and other extremities out of and away from the hopper (in-feed bin).

Point the discharge chute away from doorways, sidewalks, or any other area where your view is obstructed. The chute should be pointed downwind when possible. This will keep the chips from blowing back in the operator's direction. Keep everyone, especially children, away from the area of operation.

No loose clothing should be worn around the chipper. Personal injury can occur if someone or something turns the flywheel over when the knives are being checked or the cutter bar is being adjusted. The flywheel has enough residual energy to easily remove fingers.

WEAR PROTECTIVE GEAR!

EYES – wrap around safety glasses

EARS – ear plugs

HANDS – leather gloves

FEET – steel toed boots

LEGS – heavy pants

ARMS – long sleeved shirt

MACHINE CHECKLIST

CAUTION: Visually inspect the in-feed bin and the flywheel before applying power to ensure that the chipper head is clear, all the bolts are clear, and the knives clear the case and the cutter bar.

Make sure that:

- 1- Bystanders are at a safe distance from chipper during operation
- 2- Children should **NEVER** operate, or be near the chipper during operation.
- 3-The PTO shaft does not come apart or bottom out during the normal lifting range.

Check the chip pile to see if the knives need to be serviced. Long slivers in the chip pile are one of the best indicators of dull knives.

MACHINE OPERATION

The chipper is a flywheel-and-knife type of chipper, not a shredder. The knives actually chip the limbs they are fed into the head. The knives must be sharp to operate properly. Dirt, rocks, nails, or other foreign material will shorten knife life.

Before operating the chipper, review the machine checklist. After visually inspecting the fly wheel and in-feed bin to ensure there are no obstructions in the chipper head, start the tractor. Make sure the chipper is firmly on the ground and that the PTO shaft is no more than 15 degrees from level. The chipper must be resting on solid ground prior to operation. **DO NOT** operate while raised by 3 pt. hitch.

Start the chipper slowly (idle) with the PTO engaged. Gradually increase engine RPM until the tractor PTO speed is 540 RPM (not 540 engine RPM) The chipper is designed to run at 540 RPM. Lower RPM can damage the chipper if material jams and stops the flywheel. The material will feed into the head more easily if you start the pieces with the large end first.

The feed rollers will fold branches as they are pulled into the hopper. Occasionally, a limb fork may have to be cut to feed properly. If the material stops feeding, sometimes a little push on the long end of the limb will help.

MACHINE OPERATION

Remember to chip only clean material, or knife life will be shortened.

Do not move the chipper while the flywheel is turning.

Block the tractor wheels and set the parking brake while running the chipper.

Watch the discharge chute while operating the unit, and if the chips stop flowing, stop feeding material into the unit by pushing forward on the hydraulic control valve handle located on the side of the in-feed bin. This will

Most of the time this will be enough to clear the chips out of the unit. If the unit slows down noticeably, first shut off the PTO power, then the tractor. Unplug the head by turning it backwards by hand with the discharge chute and the top section of the flywheel housing wrap off.

Remove the chips from the top of the head. If this fails, remove the clean-out door, located in the lower part of the front side-plate of the chipper below the main shaft, and then work the chips out of the case.

Replace the clean-out door after all the chips are removed, be sure to use both the lock washers and flat washers.

Do not operate the chipper without the chip deflector in place.

Before stopping the chipper, be sure that all of the material is out of the chipper head and out of the in feed roller.

All of the material in the chute must be gone or the unit could jam on a small piece of material. This can usually be cleared by turning the unit backwards by hand.

Dull knives cause many problems such as: seeming lack of power, plugging of the discharge chute, rough cutting with more vibration than usual, feed roll shaft broken, main bearing house broken, main bearing working loose and the flywheel or knives hitting the case or bed knife, feed roller kicking out of gear, and not feeding.

When sharpening the knives, be careful to keep angle A at a 37-39° angle. Knives cannot be rounded, or the knives will not pull the material into the head. **(See Flywheel Knife Sharpening Instructions on pg. 24)**

The best way to tell if the knives need sharpening is to watch the chips coming out of the chip discharge. If they are long and straight, the knives are in need of service. Sometimes the knives feel sharp to the fingers, but may be worn or rounded. They will need to be sharpened.

LUBRICATION

Bearings - grease all bearing zerks every 10 hours of operation.

PTO Shaft – grease the two grease zerks on the universals every 10 hours of use with a high quality multi-purpose grease.

Hydraulic Tank - Fill hydraulic tank with 7 gallons of hydraulic oil, either straight hydraulic oil or universal hydraulic/transmission oil is okay. We recommend using the correct viscosity according to the temperature of the operating environment. Use the chart below to determine proper oil viscosity.

ISO Grade	SAE Grade Equivalent	Air Temperature	Operating Temperature
32	10W	30 ° - 80 °F	25 ° - 145 °F
46	20	40 ° - 100 °F	30 ° - 160 °F
68	20W	50 ° - 100 °F	35 ° - 185 °F

Shear Bolt Replacement - Grade 2, Size 5/16 x 18 x 2"

PREVENTATIVE MAINTENANCE

- Check all bolts, set-screws and fasteners after running 10 hours, and once per day thereafter.
- Check for loose belts and broken pulleys, loose springs, dry slides,
- The main drive belts on the chipper need to be tight.
- The belt of the main drive on the PTO chipper should be checked every 10 hours of operation.
- All decals and safety instructions should be kept clean and legible. It is the operator's responsibility to replace the decals as needed. They will be mailed to you at no charge.

TROUBLESHOOTING

PROBLEM: Flywheel head slows but tractor does not

Possible Causes

Main drive belts are slipping
Fly wheel knives dull

Solution

Tighten or replace if necessary
Sharpen or replace

PROBLEM: Feed rollers stop unexpectedly

Possible Causes

Hydraulic oil lever low
Air in hydraulic system
Loose belt
High pressure relief valve stuck open

Solution

Fill tank
Let sit for 1 day for air to work its way out
Tighten hydraulic pump belt
Call **WoodMaxx™** Support 855-966-3629
For personal assistance adjusting this.

PROBLEM: Not chipping clean or chip deflector plugging

Possible Causes

Flywheel knives dull
Chipper head turning too slowly

Solution

Sharpen or replace
Check PTO speed at 540 RPM

PROBLEM: Unit won't feed limbs properly

Possible Causes

Not enough down pressure on limbs
Fork in material too wide
Feed roll tension springs stretched

Solution

Adjust eyebolts to increase spring tension
Remove and trim
Replace

*To achieve proper MSED:
Remove pin and move draw
arm in or out.*



DRIVE LINE FITTING ADJUSTMENTS

This data is for drive-line fitting adjustment.

Prior to startup, the PTO that is supplied with your chipper must be properly sized to insure proper operation. If this is not done, damage to the chipper, PTO, and tractor PTO drive-line will occur. These calculations are based on the following assumptions:

The drive-line has an active length range of 20-3/4" to 25-1/4"

The two shaft ends are horizontal with one another

The following steps should be taken to insure the proper fitting of the PTO drive-line (provided with your chipper) with your tractor PTO drive.

Attach the chipper to your tractor's three point connections.

Raise the chipper to a position where its drive-shaft is level with the tractor PTO drive-shaft. The horizontal position is recommended for operation of the chipper. A maximum of 15 degrees of offset from the horizontal position between the two shaft ends is allowable for proper operation of the unit by the PTO drive-line manufacturer. However, drive-line calculations are based on a **level horizontal position**.

With the two drive shafts level with one another, measure the distance between the ends of the two shafts. (The chipper and the tractor PTO shaft ends). This distance between the two shaft ends is the measured shaft end distance, or "MSED". The PTO drive-line is capable of handling a MSED between 20" to 25-1/2", allowing for at least 1/3 of shaft overlap as recommended by the drive-line manufacturer.

If the MSED is longer than 25-1/2", a longer drive-line is needed and should be ordered.

If the MSED is shorter than 20", extend the draw arm of the chipper outward until a minimum of 20" is achieved. See [fig 25] on pg. 9

MSED

Between 23-1/4" x 25-1/4"	No adjustment needed
22"	Cut 1" from each shaft
21"	Cut 2" from each shaft
20"	Cut 3" from each shaft

DRIVE LINE FITTING ADJUSTMENTS

Most drive-lines can be adjusted to fit by cutting off equal amounts of the ends of the shaft and the guard tube of the PTO drive-line. In no case can more than 3" of shaft and guard tube be removed, or the contact area is not sufficient for proper and safe operation of the drive-shaft. Cut off the same amount from the shaft tube plastic cover and the guard tube safety cover to insure proper assembly and fit of the drive-line. Consult the drive-line manufacturer data enclosed with your drive-line for proper assembly, disassembly, lubrication and operation prior to startup and during operation.

REMEMBER: Contact with the drive-line while in use can result in serious injury or death. Any portion of the drive-line while not shielded must be guarded by an interactive guarding system. The manufacturer of the equipment is responsible for providing guards. Any replacement guard must be one which is specified by that manufacturer. In short, do not remove any of the plastic safety

covers on the drive-line and insure that caution is used around this drive-line. No one should be in the drive-line area when it is operating.

DRIVE LINE FITTING ADJUSTMENTS

Note- this is the shear bolt section of the shaft, and this end should be attached to the tractor

5/16"x18x 2"
Shear bolt



To cut the PTO shaft, unhook chain, and separate the two halves. Mark and cut equal amounts off of the plastic shields. Then, mark and cut the same amount off of the steel shafts. De-burr , grease, and reassemble the shaft. Shorten the chain so that there is no slack when the shaft is extended to its longest point.

KNIFE CHANGING/ADJUSTING

Tools You Will Need:

- Torque Wrench
- 16mm Wrench/Socket
- 17mm Socket
- 6mm Allen Wrench

STEPS:

- ✓ Detach PTO shaft from chipper. [fig. 1]
- ✓ Remove shield that covers drive belts.
- ✓ Remove access panel on front and back of flywheel chamber to expose knife bolts and nuts. [fig. 2] [fig. 3]
- ✓ Clean and remove any debris that is impacted in knife bolt allen head socket using an awl or other pointed object. Take care to clean these out thoroughly to ensure allen wrench drive bit seats properly. If not, you may strip the heads out. Air blow gun is also helpful.
- ✓ Hold the head of the M10 cap screws with a 6mm allen wrench. From the back side of the flywheel, with a 17mm socket remove the nylon lock nuts. [fig. 2]
- ✓ Remove the knives. Be careful not to drop the nuts or bolts into the flywheel chamber. If you do - See "Clearing An Object From The Flywheel Housing." [Pg 25]
- ✓ Replace knives with new or sharpened knives.
Be sure there is no debris between knife and flywheel.
- ✓ Torque knife bolts by holding M10 cap screw heads with 6mm allen wrench, then with a 17mm socket and a torque wrench, tighten nylon lock nuts to 40 ft./lbs. **DO NOT over torque bolts or knife breakage may occur.** [fig. 2] [fig. 4]
- ✓ Replace access covers front and back.

Note: Rotate the flywheel by hand to check to make sure that both flywheel knives clear the bed knife, without coming into contact with it, before applying PTO power to the chipper.



Fig. 1



Fig. 2



Fig. 3



Fig. 4

KNIFE CHANGING/ADJUSTING

Tools You Will Need:

- Torque Wrench
- 6mm Allen Wrench
- 17mm Socket

STEPS:

- ✓ Detach PTO shaft from chipper. [fig. 1]
- ✓ Remove both tension springs from in-feed roller assembly.
- ✓ Raise and support in-feed roller, a short piece of 2x4 works well for this. [fig. 2]
- ✓ Clean and remove any debris that is impacted in knife bolt allen head socket using an awl or other pointed object. Take care to clean these out thoroughly to ensure allen wrench drive bit seats properly. If not, you may strip the heads out. Air blow gun is also helpful.
- ✓ Insert short end of allen wrench into socket, allowing long end to rest against the flywheel. Hold firm so wrench does not slip out of socket.
- ✓ Using a 17mm socket, remove all three nuts from the bottom of the bed knife. Remove bed knife. [fig. 3]
- ✓ Using an air gun, blow all debris from bed kniveseat. Be sure to clear any debris that could interfere with the bed knife seating properly on the frame.
- ✓ Replace bed knife, ensure that there is (0.0200"-0.0300") of clearance between the flywheel knife and the bed knife. This is about the thickness of a credit card. [fig. 4]
- ✓ Replace all three bolts/nuts and tighten to 40 ft./lbs. with a torque wrench. DO NOT over torque bolts or knife breakage may occur.
- ✓ Replace all shields and covers.
- ✓ Re-attach PTO shaft.

Note: Rotate the flywheel by hand to check to make sure that both flywheel knives clear the bed knife, without coming into contact with it, before applying PTO power to the chipper.



Fig. 1



Fig. 2



Fig. 3

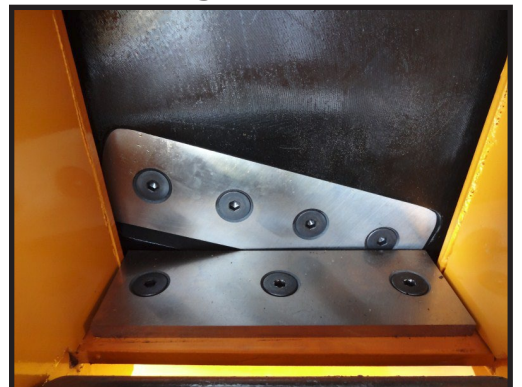

Fig. 4

FLYWHEEL KNIFE SHARPENING

SHARPEN FLYWHEEL KNIVES

STEPS:

- To properly sharpen the knives, sharpen an angle A and keep the angle about 37°-39°, the same as a new set. [fig. 1]
- Area B cannot be rounded, or the knives will not pull the material into the head.
- The best way to tell if the knives need sharpening is to watch the chips coming out of the chip discharge.
- If they are long and stringy, the knives need to be serviced. Sometimes, the knives feel sharp to the fingers, but may be worn or rounded in area B. These knives need to be sharpened.

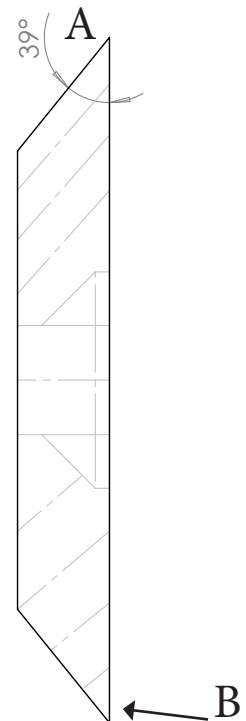

Fig. 1

CHANGING HYDRAULIC FILTER

Tools You Will Need:

- 4mm Allen Wrench
- 1" Wrench or Adjustable Wrench

STEPS:

- Remove hydraulic line from tank. [fig. 1]
- Remove screws that secure filter assembly. [fig. 2]
- Remove filter assembly and replace filter. [fig. 3]

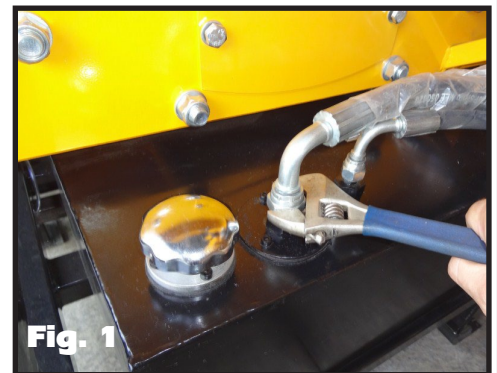

Fig. 1



Fig. 2



Fig. 3

CLEARING FLYWHEEL HOUSING

Tools You Will Need:

- 16mm Wrench

STEPS:

- ✔ Detach PTO shaft from chipper. [fig. 1]
- ✔ Locate access door on bottom of flywheel housing. There is one on the front of the machine and one on the back of the machine on the very bottom of the flywheel housing [fig. 2]
- ✔ Using a 16mm wrench, remove the two bolts that secure the access cover. [fig. 2]
- ✔ Remove cover.
- ✔ Locate/clear object from flywheel chamber. [fig. 3]
- ✔ Replace access cover/bolts.
- ✔ Re-attach PTO shaft to chipper.
- ✔ Don't drop nut again.. 😊



Fig. 1



Fig. 2

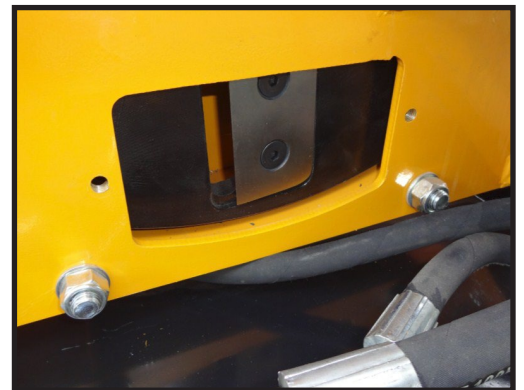

Fig. 3

CHANGING/ADJUSTING DRIVE BELT

Tools You Will Need:

- 18mm Wrench
- 4-BX-46 Belts
- 18mm Socket
- Straight Edge

STEPS:

- Detach PTO shaft from chipper. [fig. 1]
- Remove drive belt cover.
- Loosen 4 bolts that support the lower jack shaft assembly. (18mm) [fig. 2]
- Loosen 4 adjustment bolts until jack shaft assembly and belts become loose. (18mm) [fig. 3] [fig. 4]
- Remove/replace belts.
- Tighten 4 adjustment bolts until belts are tight and pulleys are parallel and in line with each other. (+/- 1/8" is acceptable) [fig. 5]
- Attach drive belt cover.
- Re-attach PTO shaft.



Fig. 1



Fig. 2



Fig. 3



Fig. 4

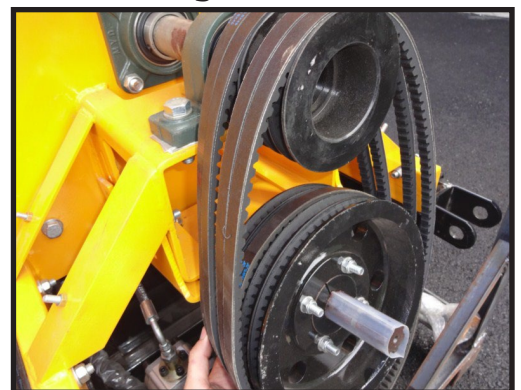

Fig. 5

WARRANTY

WOODMAXX™ POWER EQUIPMENT, LTD.

LIMITED WARRANTY

WOODMAXX™ POWER EQUIPMENT, LTD. (“**WOODMAXX™**”) warrants its products to the original retail purchaser as follows:

THREE-YEAR WARRANTY

WOODMAXX™ warrants parts only to be free from defects in material and workmanship for three (3) years from the date of original purchase except where otherwise noted. Electrical components are warranted for 60 days, beginning on the date of delivery. Proof of purchase (original receipt) is required. The exclusive remedy for this warranty is that **WOODMAXX™** will, at its option, provide repair or replacement parts for this product. **WOODMAXX™** reserves the right to discontinue or change materials, parts, models or products, or to make substitutions.

WARRANTY LIMITATIONS

This warranty does not apply to normal wear and tear, commercial or rental use, after-market modification, or damages which arise from negligence, misuse, use not in accordance with the product instructions and if in the event there is a dispute, **WOODMAXX™** in its sole discretion will make the final decision with regard to whether or not the product is covered by the **WOODMAXX™** warranty. Repairs made under this warranty will not extend the warranty period.

LIMITATION OF DAMAGES

The warranty and remedies as set forth above are exclusive and in lieu of all others, oral or written, express or implied. In no event will **WOODMAXX™** be liable for any damages, including incidental or consequential damages, arising out of the use or inability to use this product.

LIMITATIONS OF WARRANTIES

Any express or implied warranties, including warranties of merchantability and fitness for a particular purpose, shall be limited to the duration and terms of the express written warranty.

WARRANTY REPAIR POLICY

If covered replacement parts are not in stock, they will be ordered by **WOODMAXX™** and the customer will be notified when replacement parts are available. Any hydraulic component covered under this warranty that requires service will be returned to **WOODMAXX™** for repair and then shipped back upon completion. **WOODMAXX™** will not be liable for any damages associated with the unavailability of parts, including consequential damages or delay damages.

WARRANTY EXCLUSIONS

Belts, blades, hydraulic hoses, and finish are specifically excluded from this warranty. **WOODMAXX™** is not liable for any incidental damage caused by its products, including but not limited to, any damage to tractors or other machinery used in connection with its products.

TECH DRAWINGS

WM-8H Wood Chipper Parts Diagram

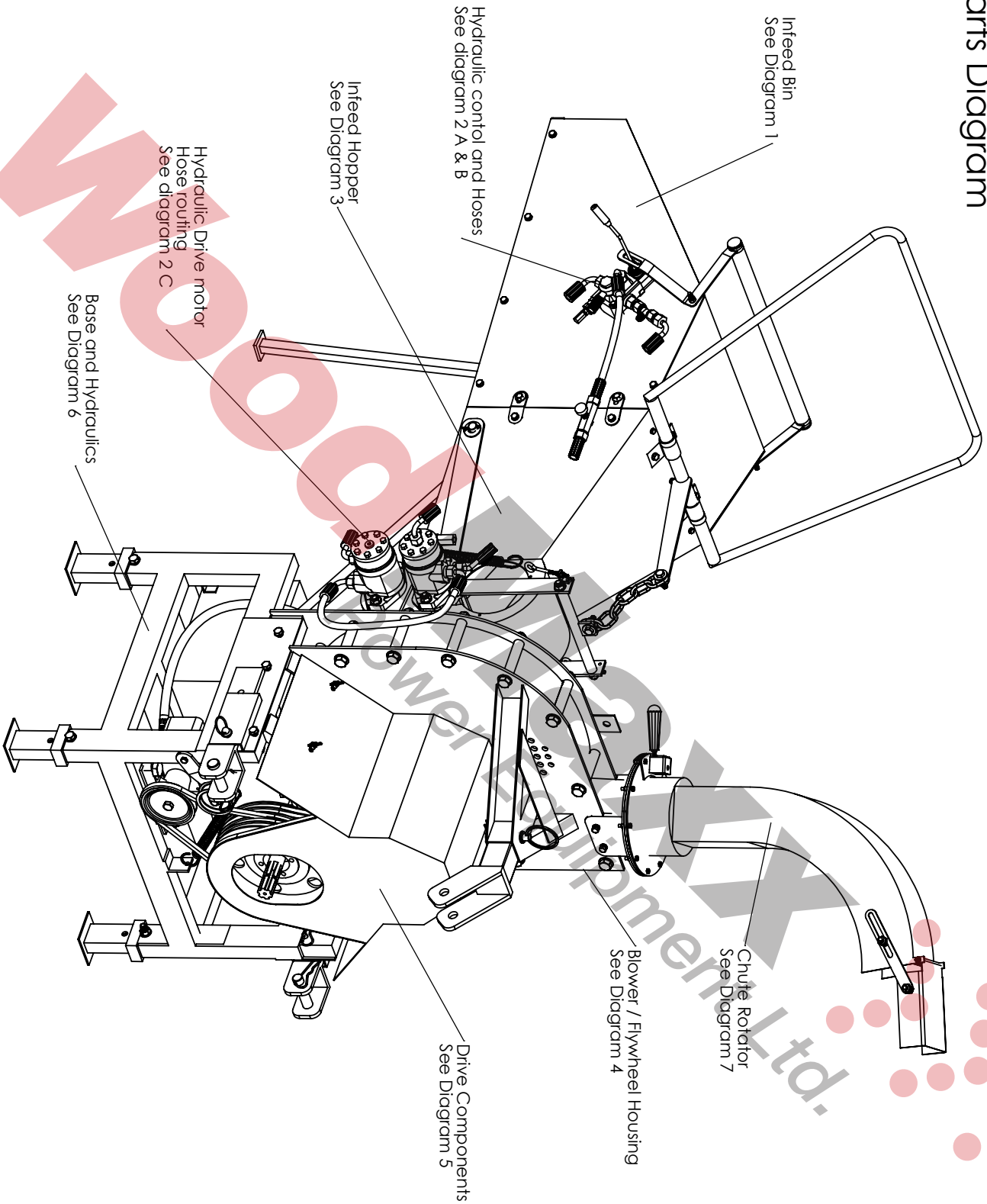

Infeed Bin Diagram 1

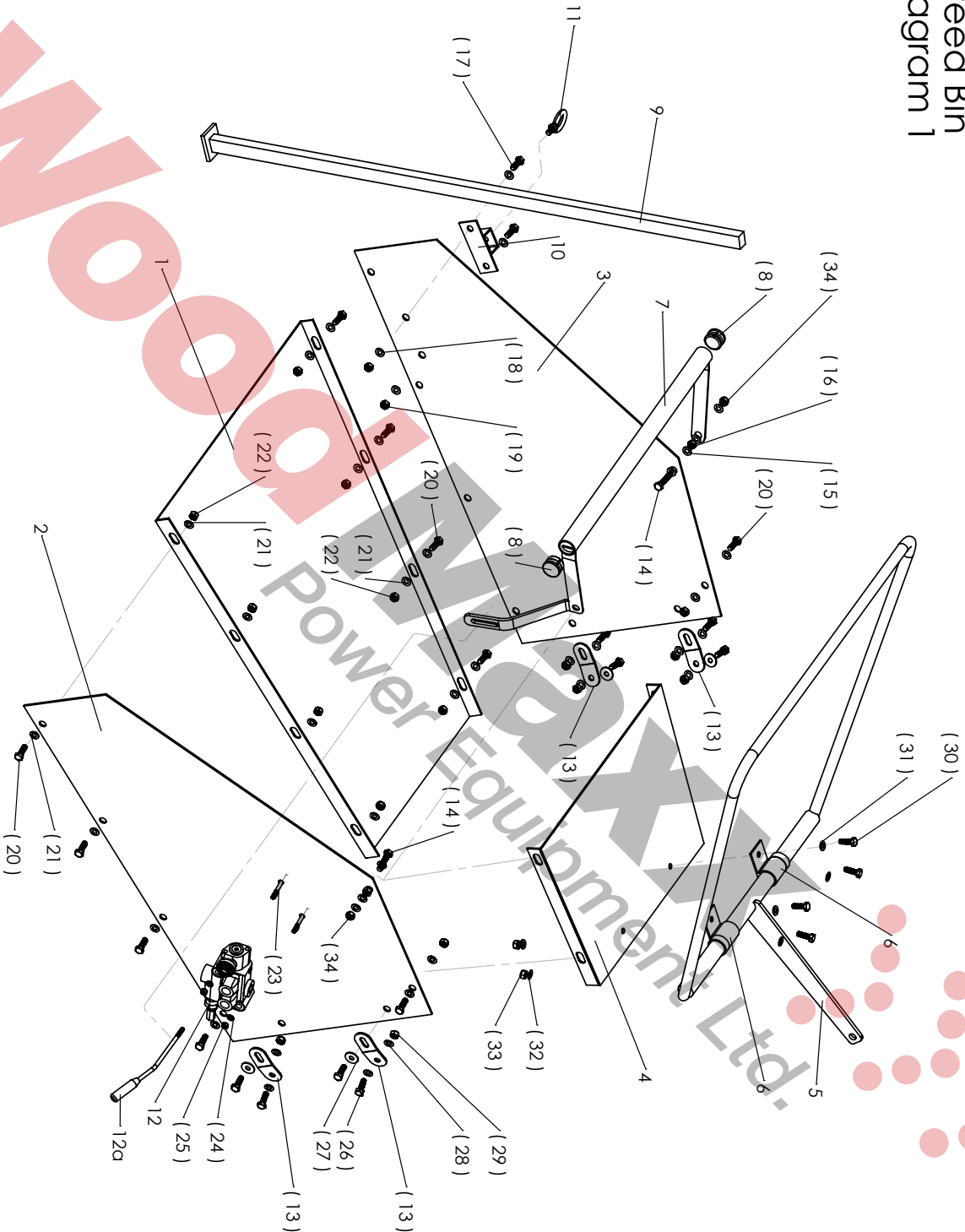

WoodMaxx Power Equipment Ltd.

WM-8H Hydraulic Wood Chipper
 Infeed Bin Parts Diagram 1

Diagram #	Part Description	Size / Detail	Qty
1	Lower bin sheet metal section		1
2	Right side bin sheet metal section		1
3	Left side bin sheet metal section		1
4	Upper bin sheet metal section		1
5	Lift lever		1
(6)	Lift lever mount brackets		2
7	Safety bar		1
(8)	Safety bar end plugs		2
9	Bin support leg		1
10	Support leg bracket		1
11	Support leg bracket lock bolt (eye bolt)	M10	1
12	Hydraulic control valve	See detail in hydraulics section	1
12a	Hydraulic control lever	See detail in hydraulics section	1
(13)	Bin attachment brackets		4
(14)	Bolt, Safety handle mounting	M10 x 40mm	2
(15)	flat washer	M10	8
(16)	Nut (plain used as spacer)	M10	2
(17)	Bolt, support leg bracket	M10 x 25mm	2
(18)	Flat washer	M10	2
(19)	Lock nut	M10	10
(20)	Bolt, bin assembly	M10 x 25mm	10
(21)	Flat washer	M10	20
(22)	Lock nut	M10	10
(23)	Bolt, for hydraulic control mount	M8 x 60mm	2
(24)	Flat washer	M8	4
(25)	Lock nut	M8	2
(26)	Bolt, bin attachment clips	M10 x 25mm	8
(27)	Fender washer	M10	4
(28)	Flat washer	M10	12
(29)	Lock nut	M10	8
(30)	Bolt, lift lever brackets	M10 x 25mm	4
(31)	Flat washer	M10	4
(32)	Flat washer	M10	4
(33)	Lock nut, lift lever	M10	4
(34)	Lock nut, safety bar	M10	2

Infeed Hopper Diagram 3

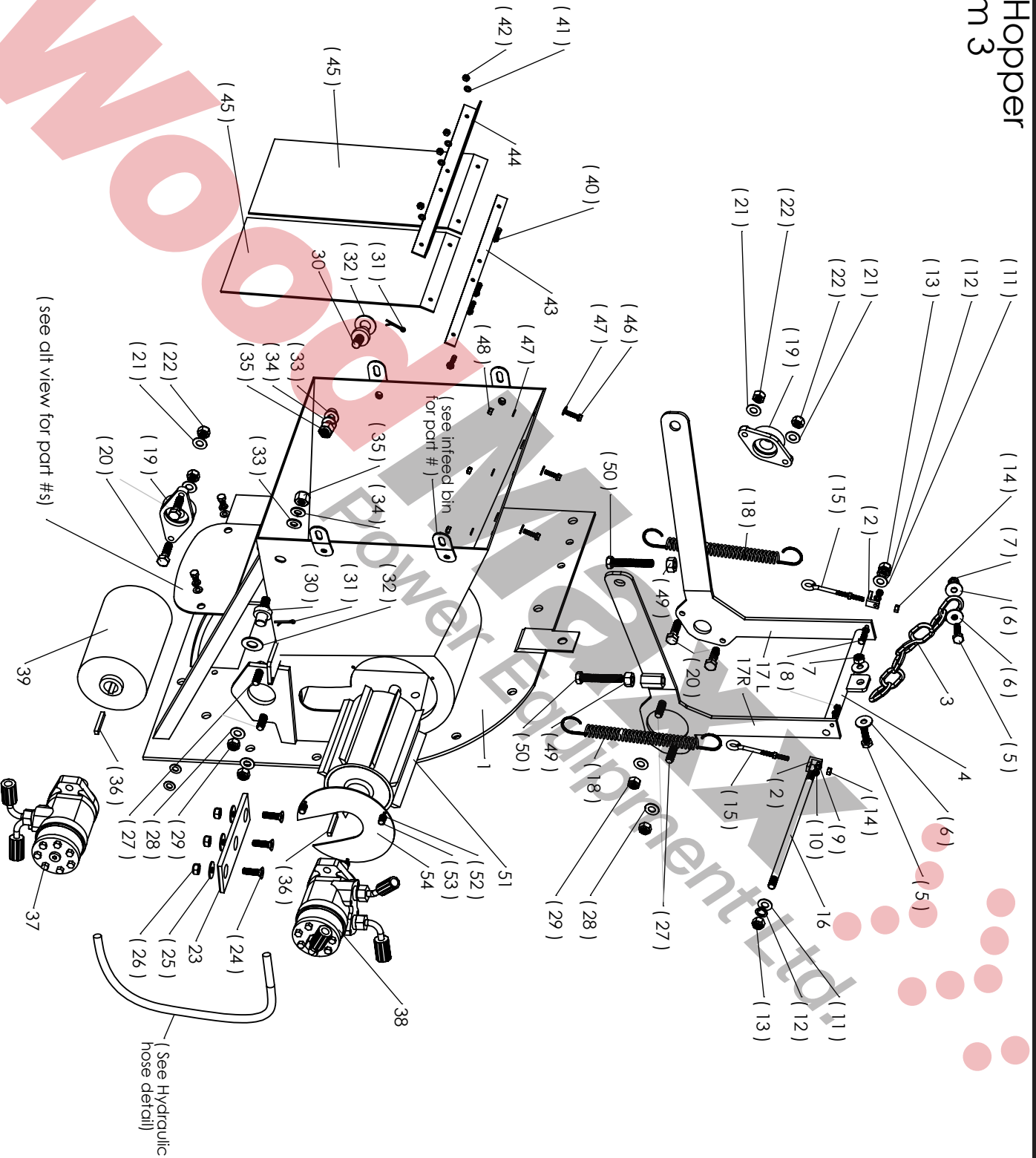

WM-8H Hydraulic Wood Chipper
Infeed Hopper Parts Diagram 3

Diagram #	Part Description	Size / Detail	Qty
1	Hopper / blower half welment		1
(2)	Angle bracket for liftsping eye bolt		2
3	Chain, lift lever attachment		1
4	Roller lift arm cross tube		1
(5)	Bolt, Chain attachment	M10 x 35mm	2
(6)	Large flat washers	M10	4
(7)	Lock nut	M10	2
(8)	Bolt, eyebolt mounting bracket	M6 x 25mm	2
(9)	Flat washer	M6	4
(10)	Lock nut	M6	2
(11)	Flat washer	M14	2
(12)	Lock washer	M14	2
(13)	Lock nut	M14	2
(14)	Nut, lift spring eyebolt	M6	2
(15)	Eyebolt, lift spring with jamb nut	M6 x 500mm	2
16	Threaded rod, roller lift arm center tube	14mm	1
17 L	Roller Lift arm bracket (left side)		1
17R	Roller Lift arm bracket (Right side)		1
(18)	Roller tension spring		2
(19)	Bearing 2 bolt flange, upper roller		2
(20)	Bolt, flange bearing	M8 x 35mm	4
(21)	Flat washer	M8	4
(22)	Lock nut	M8	4
23	Bed blade		1
(24)	Flat head socket cap screws, bed blade	M10 x 35mm	3
(25)	Flat washer	M10	3
(26)	Lock nut	M10	3
(27)	Bolt, hydr. motor mount	M12 x 40mm	4
(28)	Flat washer	M12	4
(29)	Lock washer	M12	4
(30)	Pivot pin, roller lift arm	M14	2
(31)	Cotter pin		2
(32)	Washer, large outer	M14	2
(33)	Flat washer	M14	2
(34)	Lock washer	M14	2
(35)	Lock nut	M14	2
(36)	Shaft Key, motor shaft		2
37	Lower hydraulic motor		1
38	Upper hydraulic motor		1
39	Lower infeed roller		1
(40)	Bolt, baffle mounting	M6 x 30mm	4
(41)	Flat washer	M6	8
(42)	Lock nut	M6	4
43	Flat bracket, baffle mounting		1
44	Angle bracket, baffle mounting		1
(45)	Baffle		2
(46)	Bolt, Baffle assembly mounting	M6 x 30mm	3
(47)	Flat washers for baffle assembly mounting	M6	6
(48)	Lock nut	M6	3
(49)	Nut, jam nut	M12	2
(50)	Bolt, roller gap adjustment	M12 x 65mm	2
51	Feed roller, upper		1
(52)	Flat and Lock washer	M6	3
(53)	Bolt, roller Access cover plate	M6 x 12mm	3
54	Cover plate, roller access		1

Hydraulic Control
Diagram 2A and Alt 2B

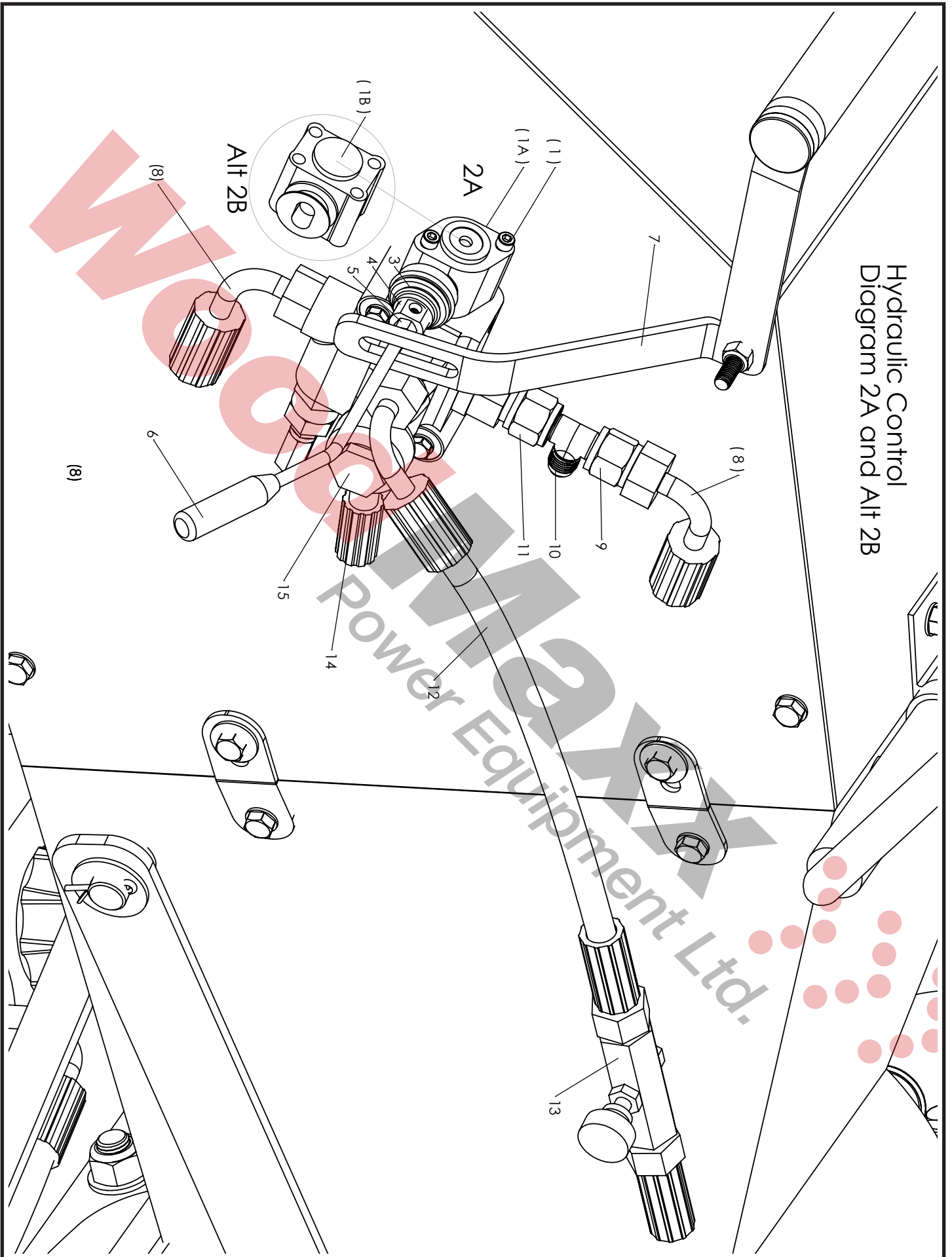

WM-8H Hydraulic Wood Chipper
Hydraulic Control Diagram 2 A & 2 B

Diagram 2 A	Part Description	Size / Detail	Qty
(1)	Cap screws	M6 x 60mm	2
1 A	Trapeziod Control valve		1
2	Hydraulic control body		1
3	Rubber lever boot		1
4	Valve actuator		1
5	Jam nut,control lever	M6	1
6	Control lever		1
7	Safety bar		1
8	90 degree outlet fitting & hose	Hose routes to top motor center	1
9	Coupler fitting		1
10	T- fitting		1
11	Coupler fitting		1
12	90 degree outlet fitting & hose	Hose routes to top motor	1
13	Flow control valve		1
14	Hose fitting and hose	Hose routes to lower motor	1
15	Banjo fitting		1

Diagram 2 B	Part Description	Size / Detail	Qty
(1)	Cap screws		2
1 B	Square control valve		1

Diagram 2 C	Part Description	Size / Detail	Qty
		House routing detail	

Hydraulic Drive Motor Detail 2 C

Hose routes to fitting 12 on control
valve
(see Hydraulic Control detail 2 A)

Routes to fitting 8
on control valve

House routes to
fitting 14
on control valve

Motors
connection
Hose

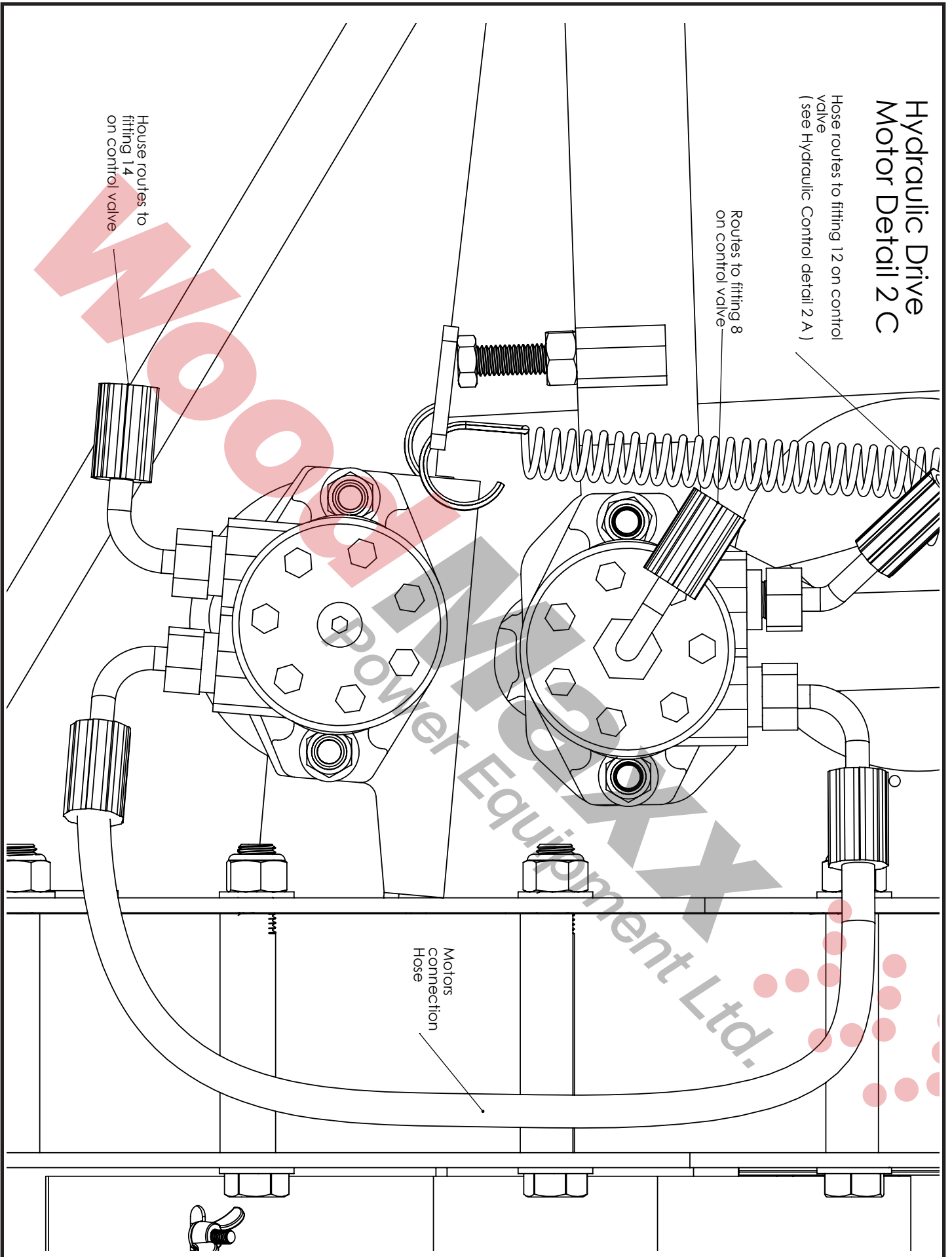

Blower / Flywheel Housing Diagram 4

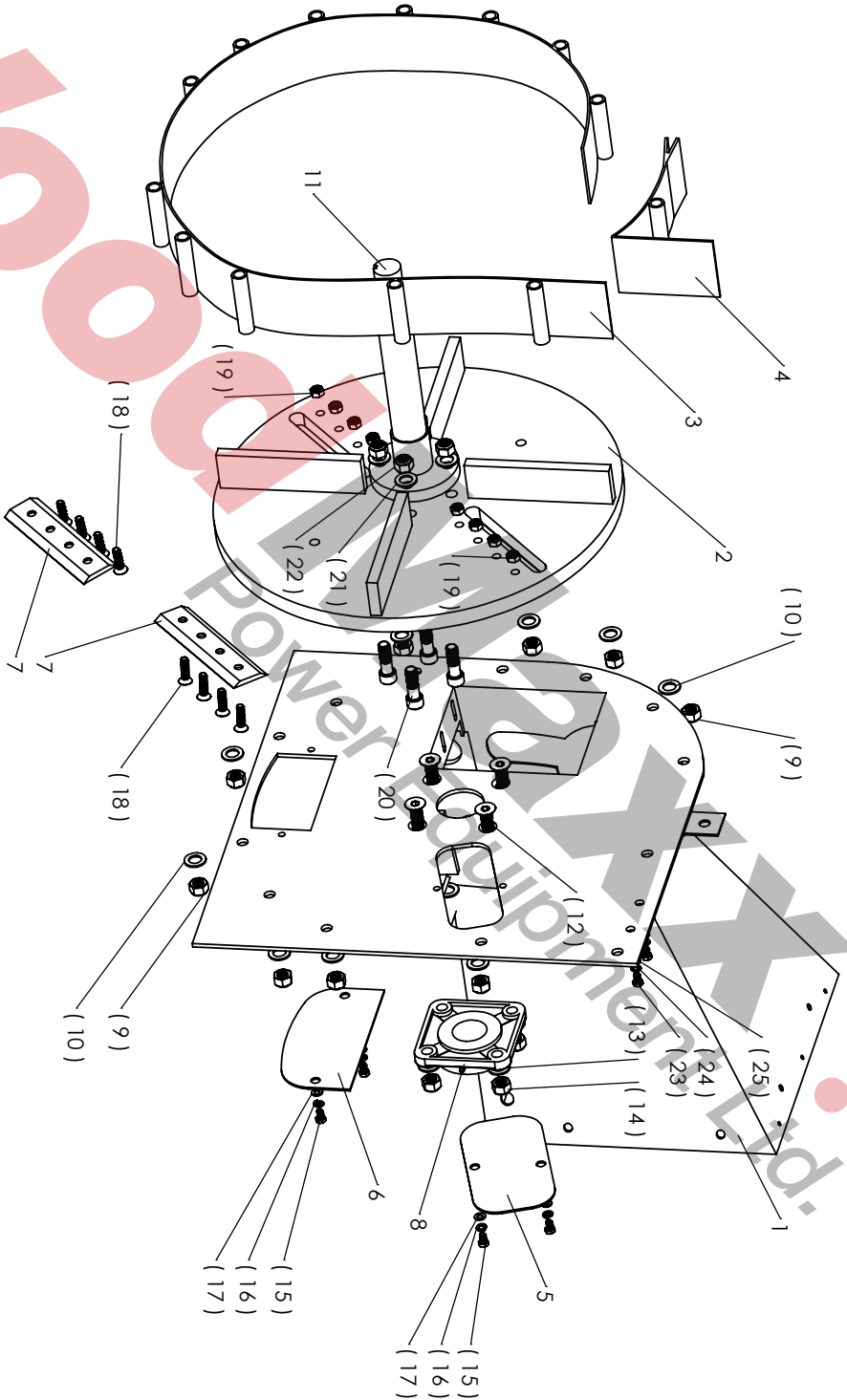

WOOD

WM-8H Hydraulic Wood Chipper
Blower / Flywheel housing Parts Diagram 4

Diagram #	Part Description	Size / Detail		Qty
1	Hopper / blower half weldment		duplicte view of part see Diagram 3	1
2	Flywheel fan weldment			1
3	Blower radius housing			1
4	Blower radius housing top section			1
5	Cover plate, knife access			1
6	Cover plate, clean out			1
(7)	Knife			2
8	Flange bearing 4 bolt		see diagram 5 for opposite side view	1
(9)	Lock nut blower housing assembly	M16 x 140mm		13
(10)	Flat washer	M16	see diagram 5 for opposite side view	13
11	Flywheel spindle shaft			1
(12)	Bolt flat head socket, flange bearing mount	M16 x 50mm	see diagram 5 for opposite side view	4
(13)	Flat washer	M16	see diagram 5 for opposite side view	4
(14)	Lock nut	M16	see diagram 5 for opposite side view	4
(15)	Bolt, cover plate(s)	M10 x 25mm		4
(16)	Lock washer	M10		4
(17)	Flat washer	M10		4
(18)	Bolt flat head socket, knife mount	M10 x 40mm		8
(19)	Lock nut	M10		8
(20)	Bolt socket head, spindle shaft mount	M16 x 60mm		4
(21)	Flat washer	M16		4
(22)	Lock nut	M16		4
(23)	Bolt, Chute adapter mount	M10 x 40mm	opposite side parts see diagram 5	2
(24)	Lock washer	M10	opposite side parts see diagram 5	2
(25)	Flat washer	M10	opposite side parts see diagram 5	2

Drive Components / Jackshaft Diagram 5 (hyd)

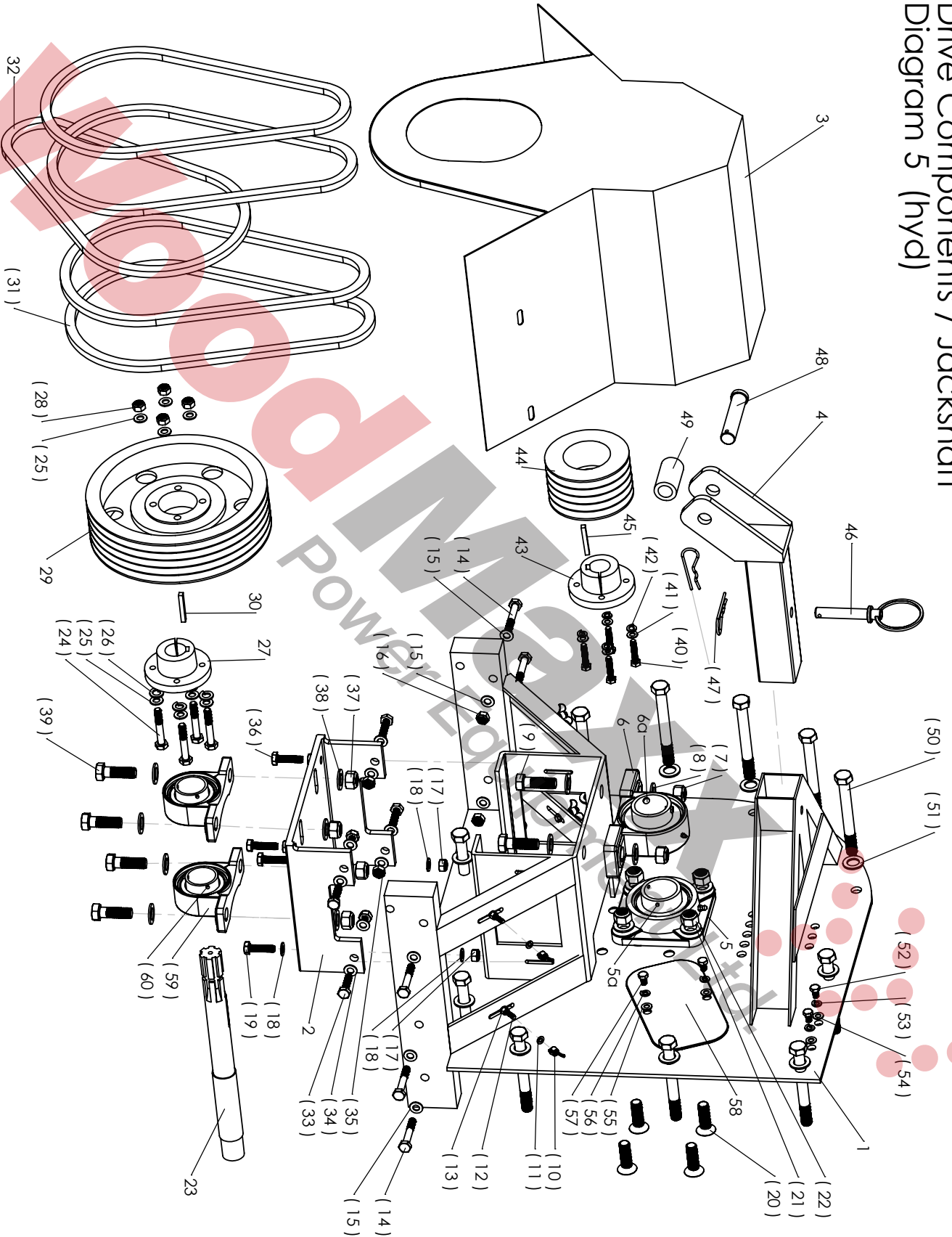

WM-8H Hydraulic Wood Chipper
Drive components / Jackshaft Diagram 5

Diagram #	Part Description	Size / Detail	Qty
1	Jackshaft / blower weldment		1
2	Jackshaft bearing mounting plate		1
3	Sheave belt cover		1
4	Top link		1
5	Flange bearing 4 bolt	see diagram 4 for identical parts opposite side	1
5a	Set screw		2
6	Pillow block flywheel spindle bearing		1
6a	Set screw		2
(7)	Lock nuts	M16	2
(8)	Flat washer	M16	4
(9)	Bolt, Pillow block bearing mount	M16 x 50mm	2
(10)	Wing nut, cover mount	M8	4
(11)	Flat washer	M8	8
(12)	Bolt, cover mount	M8 x 30mm	4
(13)	Nut	M8	4
(14)	Bolt, base to upper assembly	M10 x 60mm	6
(15)	Flat washer	M10	12
(16)	Lock nut	M10	6
(17)	Lock nut	M10	2
(18)	Flat Washer	M10	4
(19)	Bolt, jack shaft bearing mount plate	M10 x 30	2
(20)	Bolt flat head socket, flange bearing mount	M16 x 50mm	see diagram 4 for identical parts opposite side 4
(21)	Flat washer	M16	see diagram 4 for identical parts opposite side 4
(22)	Lock nut	M16	see diagram 4 for identical parts opposite side 4
23	Jack shaft		1
(24)	Bolt, taper lock / jackshaft	M10 x 30mm	4
(25)	Flat washers	M10	4
(26)	Lock washers	M10	4
27	Taper lock / jackshaft to sheave		1
(28)	Lock nuts	M10	4
29	sheave / jackshaft		1
30	Shaft key Jackshaft / Taper lock	7/16" x 2"	1
(31)	Drive belt		4
32	Pump belt		1
(33)	Bolt, jackshaft mounting plate (side)	M10 x 30mm	4
(34)	Flat washer	M10	8
(35)	Lock nut	M10	4
(36)	Bolt, Jackshaft vertical alignment adjustment	M10 x 40mm	2
(37)	Lock nut	M14	4
(38)	Flat washer	M14	8
(39)	Bolt, jackshaft pillow block	M14 x 50mm	4
(40)	Bolt, taper lock / spindle	M8 x 40mm	4
(41)	Flat washer	M8	4
(42)	Lock washer	M8	4
(43)	Taper lock / spindle shaft to sheave		1
44	Sheave, spindle shaft		1
45	Shaft key, Taper lock / Spindle shaft	3/8" x 2"	1
46	Lock pin, top link		1
(47)	Spring pin		2
48	Pin, top link		1
(49)	Bushing, upper 3 point hitch adaptor		2
(50)	Bolt, housing assembly	M16 x 160mm	13
(51)	Flat washer	M16	see diagram 4 for identical parts opposite side 13
(52)	Bolt, chute adapter	M10 x 25	see diagram 4 for identical parts opposite side 2
(53)	Lock washer	M10	see diagram 4 for identical parts opposite side 2
(54)	Flat washer	M10	see diagram 4 for identical parts opposite side 2
(55)	Flat washer	M10	see diagram 4 for identical parts opposite side 2
(56)	Lock washer	M10	see diagram 4 for identical parts opposite side 2
(57)	Bolt, cover plate Knife access	M10 x 25mm	see diagram 4 for identical parts opposite side 2
58	Cover plate, knife		see diagram 4 for identical parts opposite side 1
(59)	Pillow block bearing, Jackshaft		2
(60)	Set screws	M8-1.25 x 8mm	4

Hydraulic Base Diagram 6

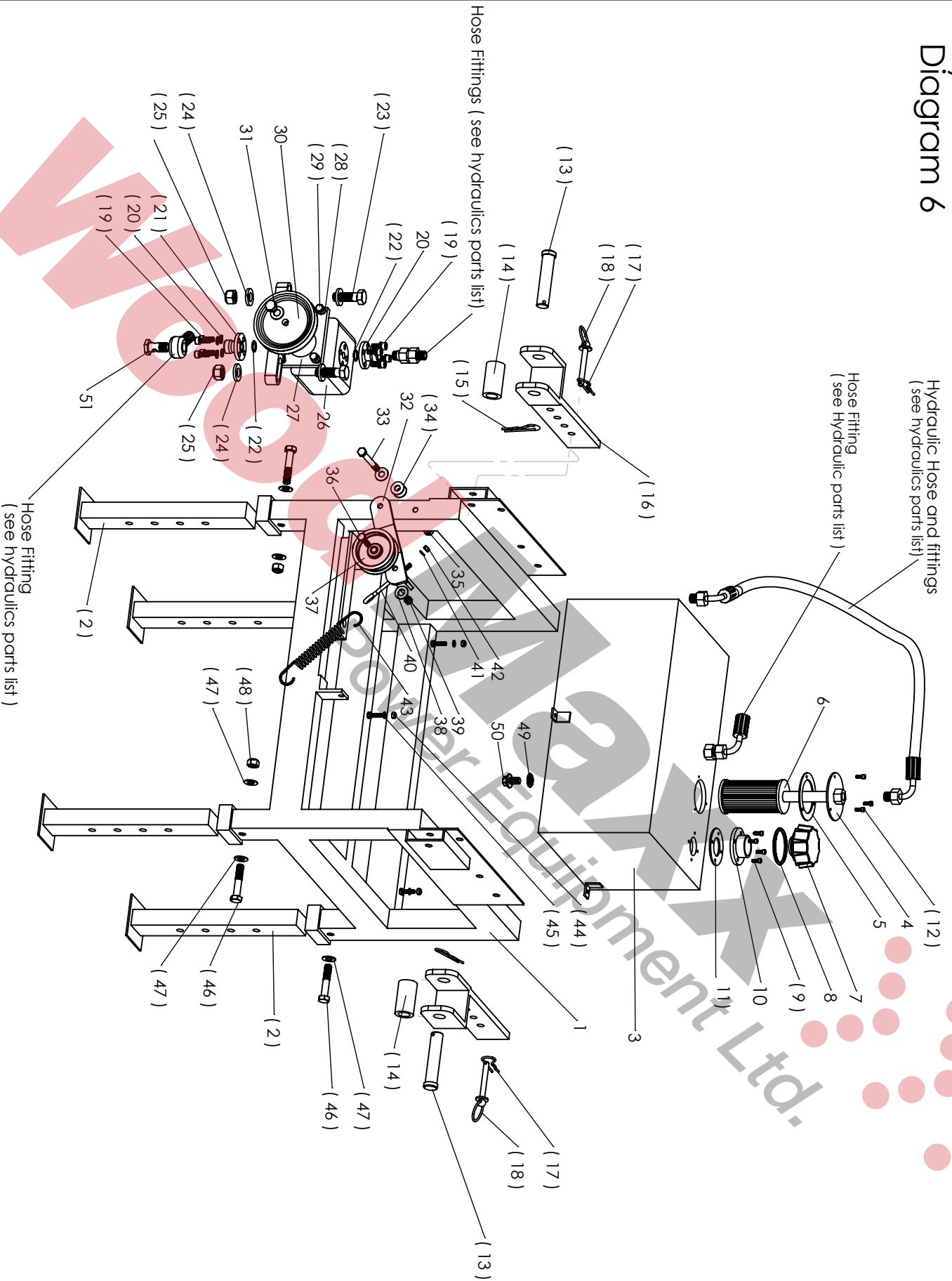

WM-8H Hydraulic Wood Chipper

Base Detail 6

Diagram #	Part Description	Size / Detail	Qty
1	Frame weldment		1
(2)	Adjustable leg		4
3	Hydraulic fluid reservoir		1
4	Hydraulic fluid filter assembly		1
5	Hydraulic filter flange gasket		1
6	Filter cartridge		1
7	Filler cap		1
8	Filler cap O ring		1
(9)	Screws socket head	M5 15mm	4
10	Filler cap flange		1
11	Filler flange gasket		1
(12)	Screws socket head	M5 x 15mm	3
(13)	Pin , 3 point hitch attachment (lower)		2
(14)	Bushing , 3 point hitch bracket (lower)		2
(15)	Cotter pin, hitch pin	3.5mm	2
(16)	3 point hitch bracket (lower)		2
(17)	Cotter pin, bracket lock pin	3mm	2
(18)	Lock pin, hitch bracket		2
(19)	Bolt socket head, pump adapter	M8 x 16mm	8
(20)	Lock washer	M8	8
(21)	Pump adapter fitting		2
(22)	O- ring, pump adapter fitting		2
(23)	Bolt, Hydraulic pump mount	M10 x 50mm	4
(24)	Flat fender washer	M10	8
(25)	Lock nut, Hydraulic pump mount	M10	4
26	Hydraulic pump		1
27	Thrust adapter, hydraulic pump		1
(28)	Lock washer	M8	4
(29)	Bolt socket head, thrust adapter to pump	M8 x 35mm	4
30	Pulley, Hyd pump		1
31	Nut, Pulley mount shaft	M12	1
32	Tensioner bracket, pump belt		1
33	Bolt, tensioner bracket mount	3/8" x 3.5"	1
34	Flat washer , Spacers tensioner alaignment	3/8"	2
35	Lock nut	3/8"	1
36	Bolt, Idler pulley mount	3/8" x 2"	1
37	Idler pulley, pump tensioner		1
38	Flat washer	3/8"	1
39	Lock nut	3/8"	1
40	Eye bolt, spring tensioner		1
41	Flat washer	M8	1
42	Nut	M8	1
43	Spring , belt tensioner		1
(44)	Nut for resevoir mount	M8	3
(45)	Flat washer for reservoir mount	M8	3
(46)	Bolt, adjustable leg	M12 x 60mm	4
(47)	Flat washer	M12	8
(48)	Lock nut for adjustable leg	M12	4
49	O- ring		1
50	Drain plug		1
51	Banjo bolt (hydraulic)		1

Chute Rotator
Diagram 7

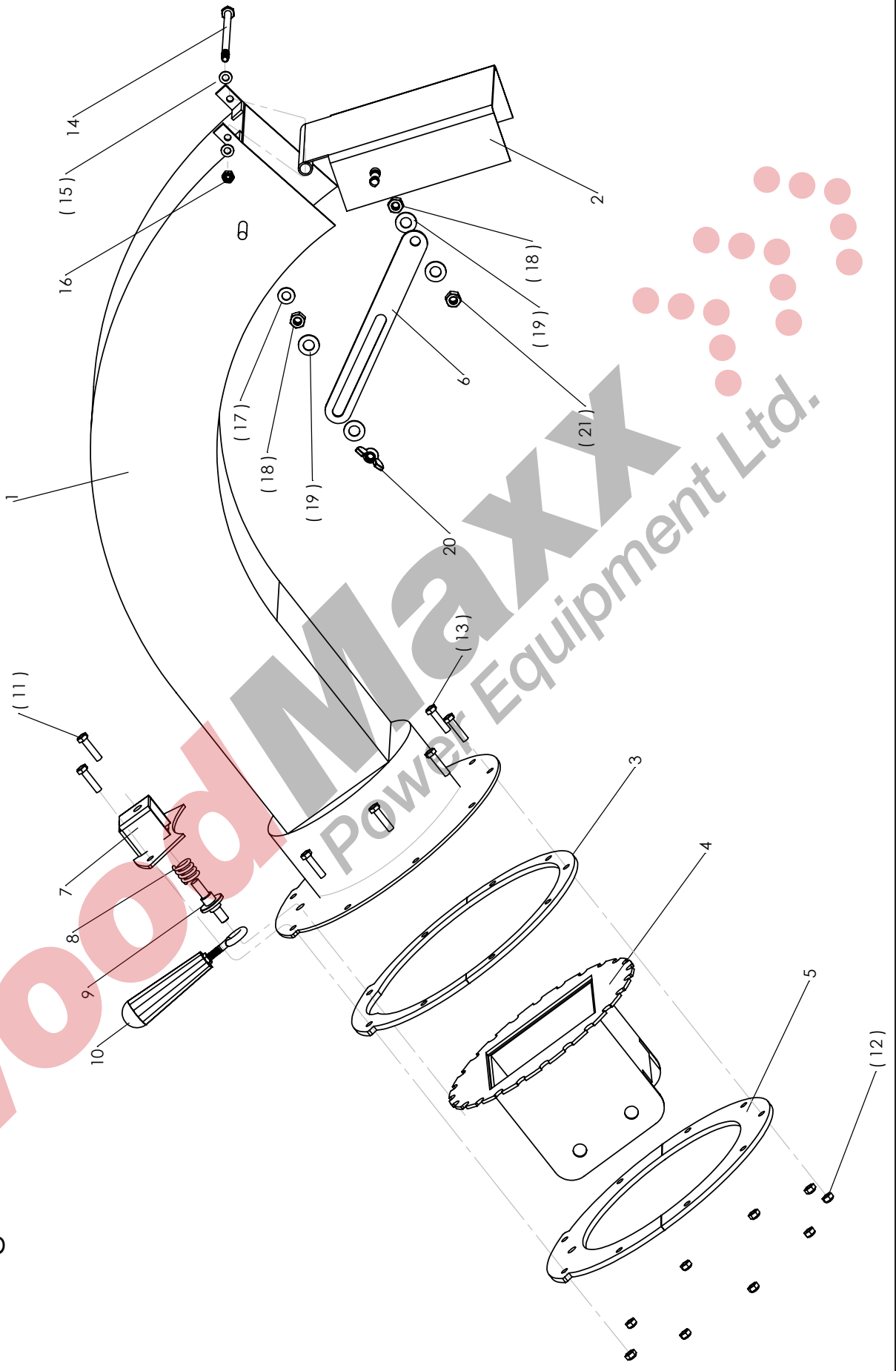

WM-8H Hydraulic Wood Chipper
Chute Rotator Diagram 7

Diagram #	Part Description	Size / Detail	Qty
1	Curved riser weldment		1
2	Bonnet		1
3	Spacer ring		1
4	Housing adaptor weldment		1
5	Lower assembly ring		1
6	Bonnet adjustment arm		1
7	Index pin housing		1
8	Index spring pin		1
9	Index pin		1
10	Handle with eyebolt		1
(11)	Bolt, index pin housing	M5 x 25mm	2
(12)	Lock nut, rotator assembly	M5	8
(13)	Bolt, rotator assembly	M5 x 20mm	6
14	Bolt, bonnet mount / pivot	M8 x 140mm	1
(15)	Flat washer	M8	2
16	Lock nut, bonnet mount	M8	1
(17)	Flat washer	M10	1
(18)	Nut spacer adjustment arm	M10	2
(19)	Flat washer		4
20	Wing nut		1