

CONTENTS

1.0 IMPORTANT USER INFORMATION	2
2.0 SAFETY	6
3.0 MOUNTING THE MACHINE	17
4.0 ROAD TRAVEL	23
5.0 PARTS OVERVIEW	28
6.0 PRELIMINARY CHECKS	33
7.0 SEED DISCS	35
8.0 COULTERS	39
9.0 ROW UNITS	43
10.0 TOOLBAR	46
11.0 PREPARATION IN THE YARD	47
12.0 PREPARATION IN THE FIELD	53
13.0 FIELD OPERATION	55
14.0 AFTERCARE	57
15.0 DISMOUNTING THE MACHINE	59
16.0 GENERAL MAINTENANCE	61
17.0 METERING UNIT MAINTENANCE	67
18.0 FAN MAINTENANCE	72
19.0 LANDWHEEL MAINTENANCE	74
20.0 TOOLBAR MAINTENANCE	76
21.0 ROW UNIT MAINTENANCE	77
22.0 LOADING WORK	78
23.0 DECOMMISSIONING AND DISPOSAL	79
24.0 TECHNICAL DATA	80
25.0 TROUBLESHOOTING	81
26.0 SEED SPACING CALCULATIONS	83
27.0 SPACING CHARTS	84

1.0 IMPORTANT USER INFORMATION

1.1 INFORMATION REGARDING THE OPERATOR MANUAL

This operator manual contains important information regarding the handling of the machine and the unit. Observing all specified safety instructions and handling instructions is a prerequisite for safe work.

Carefully read this operator manual before starting any work. The operator manual is a part of the product and must be kept in the immediate vicinity of the machine or unit and must be accessible to the personnel at all times. An incomplete or illegible operator manual must be immediately replaced by a new operator manual.

This operator manual is part of the machine and must be handed to the buyer when the machine is resold. The operator manual is also available in other languages.

Supplementary to the operator manual, the legal, general and other binding regulations regarding the prevention of accidents and protection of the environment must be heeded and instructed.

1.2 VALIDITY OF THE OPERATOR MANUAL

This operator manual only applies to machines with ProAir row units fitted. All chapters in this operator manual are relevant for the series mentioned.

1.3 LOCATION INFORMATION IN THE OPERATOR MANUAL

The location information front, rear, left and right always refers to the direction of motion.

1.4 PRE-DELIVERY AND INSTALLATION

Before delivery Stanhay Webb Ltd, or their dealer, will undertake certain activities when supplying a new machine. This pre delivery inspection will ensure that the machine delivered is:

- Correct to order requirements fully assembled with all options required, and ready for use.
- The delivery procedure will provide you the customer, with comprehensive instruction in the basic principles of operation of the product and of its maintenance in addition to the generalised information contained within this manual.
- These instructions will cover controls, daily and periodic maintenance and safety precautions.
- It is the owners responsibility to ensure that all persons concerned with the operation of the machine are present for, or informed of this instruction.

THE STANHAY TEAM WISHES YOU A SUCCESSFUL SEASON WITH YOUR NEW MACHINE.

1.0 IMPORTANT USER INFORMATION

1.5 USE AS INTENDED

The ProAir precision seeder is suitable for drilling various types of small seed. The precision seeder is exclusively intended for attachment to a tractor in accordance with the requirements and may only be used for agricultural purposes within the scope of application described in this manual.

Using the machine for any other purpose or making unauthorised changes, the use of unauthorised spare parts, accessories or auxiliaries shall be considered contrary to the intended use. The manufacturer is not liable for any damages resulting from this; the risk is solely with the user.

The precision seeder may only be used by authorised persons who have been introduced to the machine functions.

The accident prevention regulations as well as other safety, occupational health and road traffic regulations must be adhered to at all times when using the machine.

The operator manual enclosed with the precision seeder forms an integral part of the machine. The machine is exclusively intended to be used in accordance with this operator manual. Any use beyond the functions described in the operator manual can lead to serious personal injuries as well as machine damage.

The information regarding operation, service and safe handling - as specified by the manufacturer in this operator manual and in the form of warning notes and warning labels on the precision seeder must be observed.

Clarify any information in the operator manual that is not understood before initial machine operation. Please do not hesitate to contact the Stanhay dealers or Stanhay Webb Ltd. for any questions you may have regarding the machine or operator manual.

1.0 IMPORTANT USER INFORMATION

1.6 DECLARATION OF CONFORMITY



The manufacturer:

Stanhay Webb Ltd
BCS House, Pinfold Road, Bourne, PE10 9HT, United Kingdom

Herewith declares under it's sole responsibility that the machine:

Machine type:	ProAir precision seed drill
Machine number:	from S85-00001

Is compliant with the provisions of the following EU guidelines:

- Directive 2006/42/EC, Official Gazette of the EU L157/24 of 9 June 2006 (Machinery Directive)

The following harmonized standards were applied:

- EN 14018:2005+A1:2009 - Agricultural and Forestry Machinery - Seed Drills - Safety

I hereby declare that the equipment named above has been designed to comply with the relevant sections of the above referenced specifications. The unit complies with all essential requirements of the Directive.

Name: Chris Fletcher

Position: Managing Director

Done at: Bourne UK

Date: 1st January 2020

1.0 IMPORTANT USER INFORMATION

1.7 PRODUCT DATA

Manufacturers Address
 Stanhay Webb Limited,
 BCS House,
 Pinfold Road,
 Bourne,
 Lincolnshire
 PE10 9HT
 UK
 Phone Number: +44 (0)8451 801480
 info@stanhay.com
 www.stanhay.com

1.8 DETAILS FOR ENQUIRIES AND ORDERS

Original spare parts and accessories approved by the manufacturer should only be used. Failure in doing this would result in invalidating the manufacturers warranty and could increase safety risks.

When ordering spare parts make sure to quote the stock code and serial number which can be found on the VIN plate which is located on the headstock of the drill.

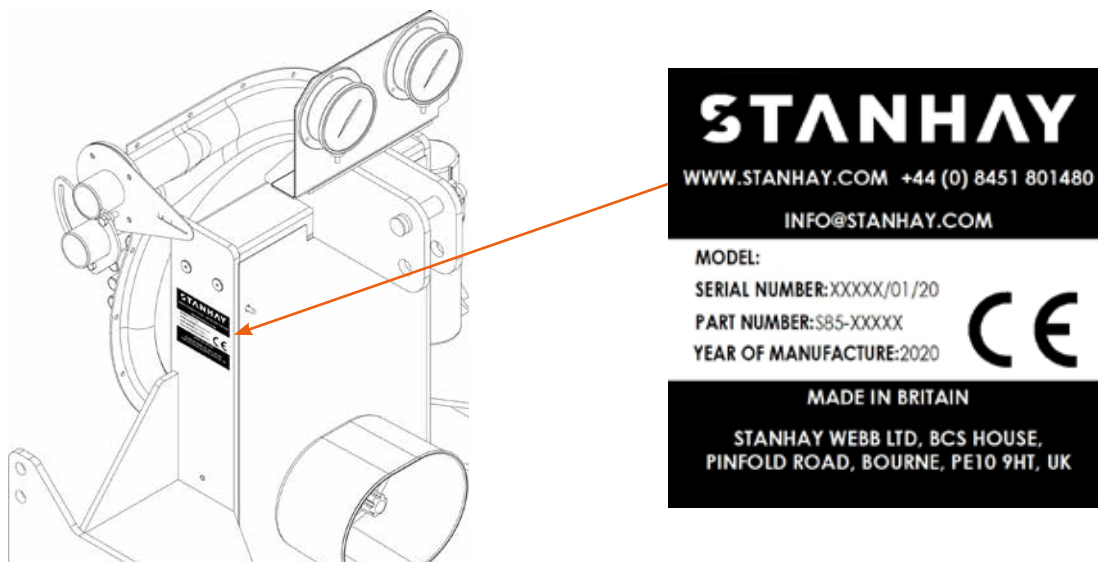

The VIN plate is a certificate and is an integral part of the drill. This must not be removed, changed or made illegible.

1.9 STANHAY SERVICE

Stanhay service will assist with any technical information. Information can be received at any time from a member of staff via telephone, e-mail or via the internet. For more information see contact details on the rear of this manual.

1.10 COPYRIGHT

This operator manual should be treated as a confidential document and its intended use is solely for the operator. Failure to abide by this may result in legal action.

2.0 SAFETY

2.1 SAFETY

This operator manual contains basic information that must be observed during installation, operation and maintenance. It is therefore absolutely necessary that this operator manual is read by personnel before initial use and operation and that it is accessible to personnel at all times. Clarify any information in the operator manual that is not understood before initial machine operation. Please do not hesitate to contact the Stanhay dealers or Stanhay Webb Ltd for any questions you may have regarding the operator manual.

The general safety instructions listed under this main topic “Safety” must be observed, together with the specific safety instructions that are located in other sections of the manual.

Apart from the information in this operator manual, the pertinent regulations for the prevention of accidents as well as other generally recognised regulations with regard to safety and occupational health must be observed.

If safety instructions are not complied with, you risk injury to yourself and others as well as damage to the environment or the machine. Non-compliance with safety instructions can also void any claims for damages.

2.2 EXPLANATION OF SYMBOLS

In this operator manual, warnings are marked by symbols. These notes are preceded by signal words that express the extent of the hazard. Always observe these instructions and act cautiously in order to avoid accidents, personal injuries and damage to property.

STRUCTURE OF A WARNING NOTICE



SIGNAL WORD

- Type and source of danger
- Consequences if the warning is ignored.
- Measures to avert the danger.

WARNINGS



DANGER!

Identifies a danger which may lead to death or serious injury if it is not avoided.



WARNING!

Identifies a danger which may lead to death or serious injury if it is not avoided.



CAUTION!

Identifies a danger which may lead to injuries if it is not avoided.



NOTE

Indicates immediate situations which will lead to machine damage if they are not avoided.



INFORMATION

Emphasises useful tips and recommendations as well as information for an efficient and smooth operation.



ENVIRONMENT PROTECTION MEASURE

Signals measures that must be taken to avoid damage to the environment.

2.0 SAFETY

2.3 OPERATOR RESPONSIBILITY

The machine and/or the unit are used in commercial applications; the owner is therefore subject to the statutory requirements for safety at work. In addition to the instructions on occupational health and safety in this operator manual, you must observe the safety instructions, the instructions for the prevention of accidents and the regulations for the protection of the environment. The following should particularly be observed:

- The operator must familiarise himself with the applicable occupational health and safety requirements and, if necessary, carry out a risk assessment to determine potential risks that result from the specific working conditions at the location of the machine and/or unit.
- The operator must clearly allocate and define the responsibilities for installation, operation, maintenance and cleaning of the machine.
- The operator must ensure that the personnel handling the machine or device has read and understood the operator manual. Apart from that, he must train personnel at regular intervals and inform personnel about the dangers involved.
- The operator is also responsible for maintaining the machine and/or unit in a technically faultless state, and that the necessary inspections and the required maintenance and repair work are carried out at regular intervals so that the machine is left in a safe condition to use at all times.

2.4 OPERATING PERSONNEL

To avoid personal injury and material damage, persons working on this machine must meet the following minimum requirements:

- They are physically capable of controlling the machine.
- They are able to carry out the work with the machine within the scope of this operator manual in a safe manner.
- They understand the machine's mode of operation and are able to recognise and avoid the dangers associated with their work.
- They have understood the operator manual and are able to apply the information in the operator manual accordingly.
- They are a competent operator of the vehicle attached to this machine.
- If the machine is to be taken on the road then the operator must be familiar with the relevant road traffic laws in that country and hold the required driver's license/documentation. The responsibility for this rests with the operator of the machine.

The following qualifications for specific tasks are defined in the operator manual:

2.4.1 INSTRUCTED PERSONNEL

An instructed person is he/she who has been instructed and where necessary trained to operate the machine. An instructed person will be made aware of the potential dangers in case of incorrect operation and has also been instructed with regard to necessary guards and protective measures. Instructed personnel include the owner and the operator of the machine.

2.4.2 SPECIALIST STAFF

Due to their technical training, know-how, experience, and knowledge of the applicable regulations, specialist staff are able to carry out the assigned tasks and to recognise potential risks on their own. Specialist staff included, but not limited to, Stanhay staff and service technicians, Stanhay dealers and specialist technicians.

2.0 SAFETY

2.5 PERSONAL PROTECTIVE EQUIPMENT

Wearing the correct personal protective equipment when operating this machine is important and should be adhered to at all times. Missing or unsuitable personal protective equipment increases the risk of serious health problems and injuries of persons. Personal protective equipment comprises for instance:

- Protective gloves
- Safety shoes
- Protective clothing
- Reflective clothing
- Respiratory protection
- Hearing protection
- Face and eye protection when dealing with chemicals
- Wear suitable clothing - Loosely worn clothing increases the danger of getting caught or drawn into rotating parts or protruding parts. Persons may get seriously or fatally injured by this.
- Never wear rings, chains and other jewellery.
- Long hair must be tied or covered up to reduce the possibility of entanglement.
- Safety footwear.

2.6 SPECIAL RISKS

The following section lists the residual risks resulting from the risk analysis. Note the safety instructions listed here and the warnings in the other chapters of this operator manual in order to reduce health risks and to avoid hazardous situations.

2.6.1 NOISE

**DANGER!**

Risk of hearing damage due to noise! The noise level occurring in the working area may cause serious hearing damage.

- Always wear ear protection during work.

2.0 SAFETY

2.7 GENERAL SAFETY INSTRUCTIONS AND ACCIDENT PREVENTION

The safety advice and information given in this operator manual, the applicable national regulations concerning accident prevention and any applicable internal work, operating and safety instructions of the operator must be observed.

- Warning signs and other notices on the machine provide important information for safe operation. Observing them will contribute to your own safety.
- Before starting to work, familiarise yourself with all of the installations and controls and their functions.
- Keep the machine clean to avoid the risk of fire.
- Check the overall visibility of the machine and vehicle from the operator position before pulling away and initial operation. Pay attention to blind spots and if necessary request a banksman.
- Do not start up the machine unless all guarding equipment has been fitted and is in its protective position.
- Stay clear of the turning radius of the machine.

2.8 SAFETY INSTRUCTIONS ON THE HYDRAULIC SYSTEM

- Carry out repair, maintenance and cleaning work on the hydraulic system only with switched off engine and non-pressurised hydraulic system.
- Hydraulic systems on the machine are under high pressure. Fluids (hydraulic oil) escaping under high pressure can penetrate the skin and cause serious injuries.
- Make sure that the hydraulic system, of the tractor as well as of the machine, is non-pressurised when connecting the hydraulic hoses to the tractor's hydraulic system.
- Hot hydraulic oil can cause serious burns!
- Take care when working on a hot hydraulic system. Let the hydraulic system cool down and wear protective gloves.
- Inspect hydraulic hoses at regular intervals and replace if damaged or worn. The exchanged lines must comply with the technical requirements provided by the machine manufacturer. Hoses and hose couplings undergo a natural ageing process, even if stored and used correctly; therefore, their period of storage and use is limited. Deviating from these figures, the service life of a hose may be determined according to empirical values, in particular taking into account hazard potential.

2.0 SAFETY

2.9 SAFETY INSTRUCTIONS FOR MOUNTED MACHINES

- There is a risk of injury when attaching or detaching machines to/from the towing vehicle. Pay attention to pinch and shear points.
- Beware of pinch and shear points when operating the parking stand.
- Never allow persons to stand between the towing vehicle and the machine whilst in motion.
- Only attach the machine in accordance with the instructions and only to the prescribed fixtures.
- Follow the operator manual of the towing vehicle.
- Observe permissible dimensions and weights of the vehicle after attaching machines or equipment. The vehicle possibly no longer complies with the general road traffic regulations due to the larger dimensions (length, width, height) and this can cause the expiration of the vehicle's operating permit. It is only permitted to participate in public road traffic taking into consideration the respective legal regulations for machines exceeding the admissible dimensions and weights.
- During transport, secure all moving parts with the safety devices provided to prevent them from moving and to avoid possible accidents!
- Driving, steering, and braking characteristics are influenced by fully mounted or attached machinery and ballast weights. Therefore, pay attention to adequate steering and braking ability.
- Switch off the engine and remove the ignition key before leaving the towing vehicle.
- All powered items (e.g. hydraulic) exhibit pinch and shear points! During operation, it is therefore forbidden to remain within the moving circumference of these parts or to reach into areas where there is a risk of injury due to pinching or shearing.
- Dangerous implements, which may still 'coast' after their drive is switched off, are mounted behind guard assemblies. Therefore, keep well clear until such parts have come to a complete stop. It is forbidden to open or remove guarding equipment such as covers, flaps, etc. on the machine whilst it is in operation! Never reach under guarding equipment.
- Do not carry out any maintenance, repair or cleaning work and do not eliminate any malfunctions on the machine unless the drive and the engine are switched off. Remove the ignition key from the towing vehicle.
- Never stand or work beneath a raised machine. Persons are only allowed to stand or work under suspended machines or machine parts when safety props are fitted (e.g. trestle, crane). This applies in particular for repair and maintenance work.
- Wear suitable protective clothing (protective gloves, safety shoes, etc.) when handling sharp implements, e.g. cutters.
- Do not start up the machine unless all guard assemblies have been fitted and are in their protective position. It is forbidden to open or remove guarding equipment such as covers, flaps, etc. on the machine whilst it is in operation.

2.0 SAFETY

2.10 IN THE EVENT OF AN ACCIDENT

- Stop the machine immediately.
- If necessary initiate first-aid measures.
- If danger is still present move the person to a safe location.
- Inform the responsible person at the site of operation.
- Alert the necessary emergency services.
- Clear the access roads for emergency vehicles.

2.11 IN THE EVENT OF AN ACCIDENT



DANGER!

Risk of injury! Serious injuries and death possible!

Persons can be seriously or fatally injured through the machine's travelling motions and/ or through moving parts.

- Switch off the engine prior to any work which requires staying in the danger zone. Remove the ignition key as a precaution, and secure the machine against rolling away.
- The operator is responsible for immediately stopping the machine as soon as persons enter the danger zone or use objects to reach into the danger zone.
- Switch off engine and remove ignition key before carrying out any maintenance and repair work.

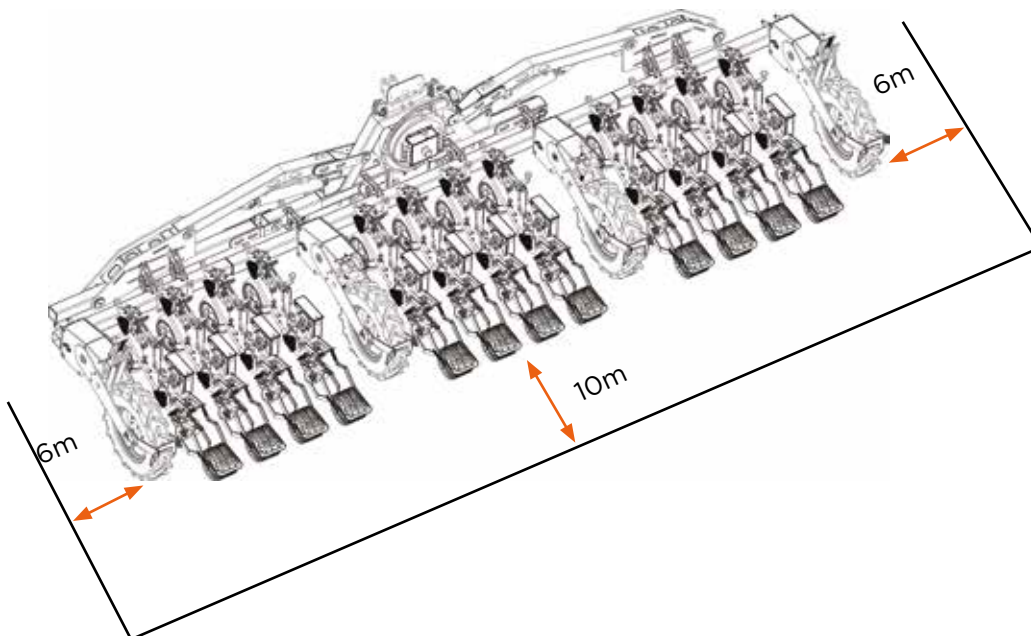

The danger zone is defined by a specified distance to the machine's external dimensions. If the machine dimensions are extended on account of folding elements or additional attachment parts, the danger zone is extended accordingly.

During operation of the machine, nobody may stay in the danger zone. In case of danger, the operator must immediately stop the machine and request the persons concerned to immediately leave the danger zone. The machine may only be restarted once the danger zone is clear of people.

2.0 SAFETY

2.12 WARNING AND INFORMATION DECALS ON THE MACHINE

The warning labels on the machine indicate areas of danger. Observing these warning labels will contribute to the safety of all persons working on or near the machine. The information on these warning labels must be heeded. All safety instructions must also be passed on to other (new) users. Warning and information labels must be kept in a clean and legible condition at all times.

Replacements for damaged or missing warning and information labels must be immediately ordered from your Stanhay dealer and reattached in the designated places.

2.12.1 WARNING DECALS ON THE MACHINE



It is prohibited to be located in the vicinity of the drive shaft - risk of injury!



Do not stand between the machine and the tractor.



Read the operator manual before operating the machine



Do not stand in the folding range of the folding frame



Do not stand in the folding range of the marker arms



Never reach into the crushing area when parts are moving.



Do not open or remove safety guards while the machine is in operation.



Do not exceed 540rpm shaft speed (540 PTO Only)



Do not exceed 1000rpm shaft speed (1000 PTO Only)



Do not exceed 30LPM (Hydraulic Fan Only)

2.0 SAFETY

2.12.2 INFORMATION DECALS ON THE MACHINE



Toolbar setting height



Always place seed disc in bag after use



Grease Points



Indicates lifting points on the drill

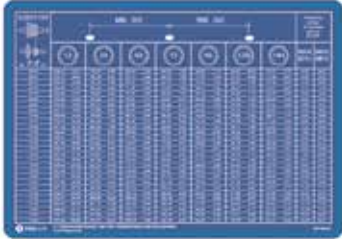

Gear ratio table



Tyre pressure label

2.0 SAFETY

2.12.3 DECAL LOCATIONS

LEFT VIEW

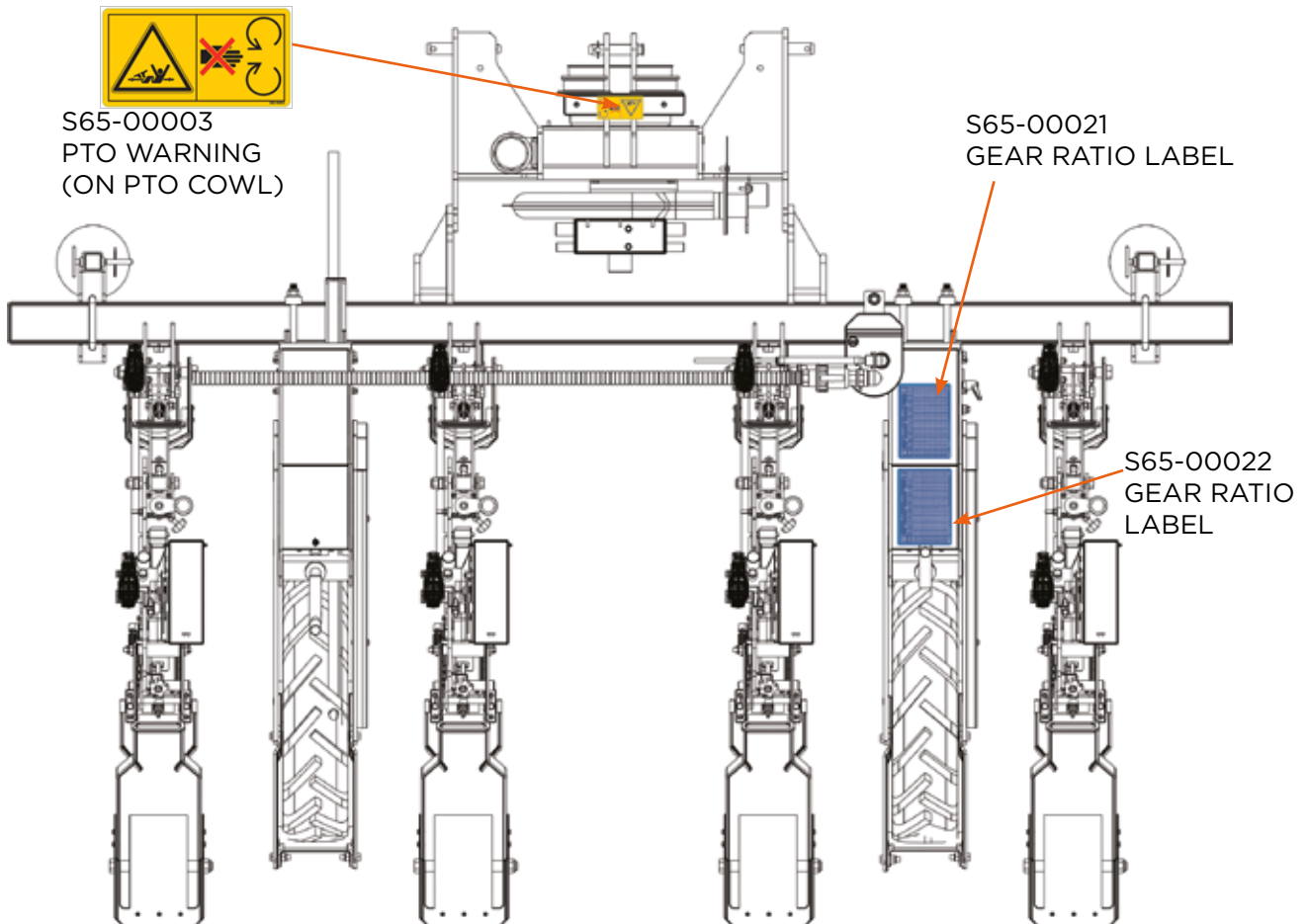
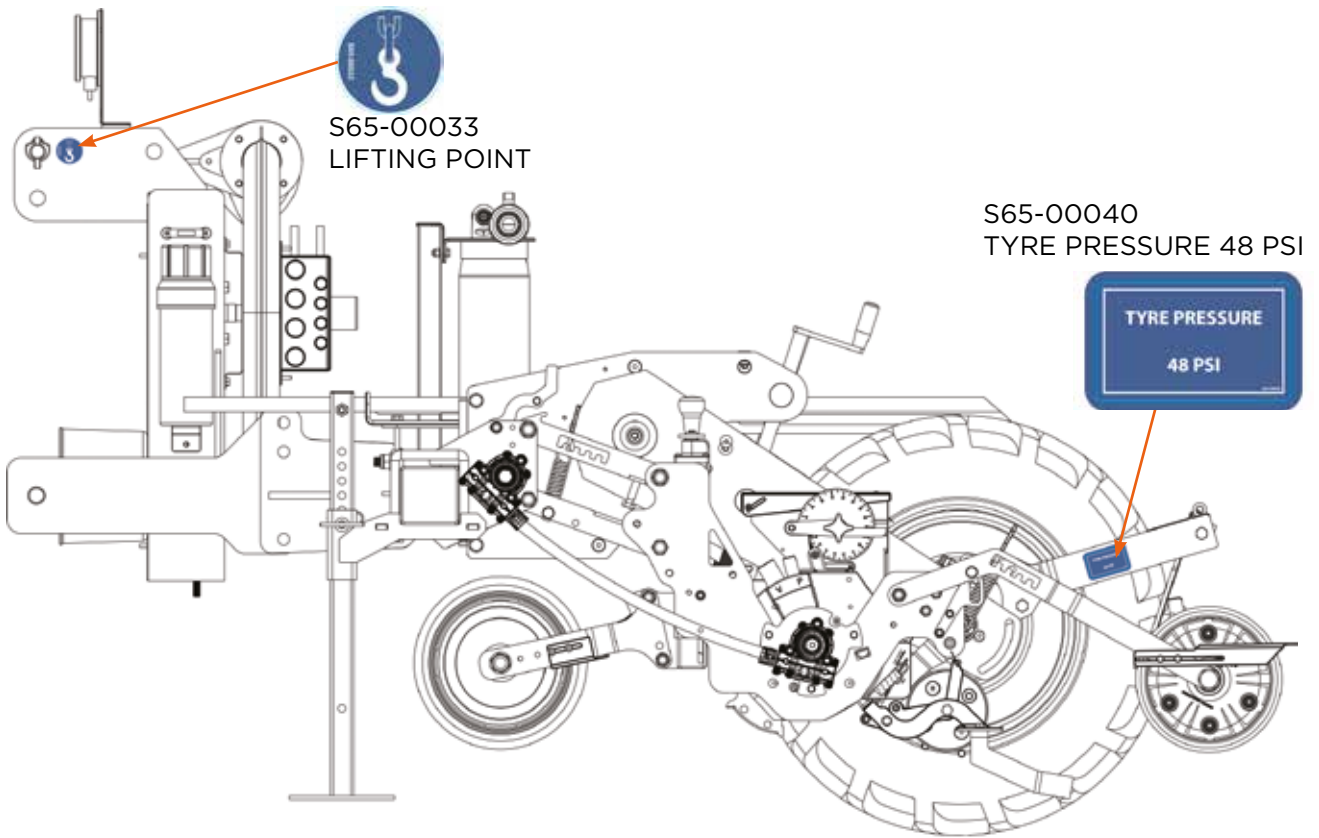

2.0 SAFETY

FRONT VIEW

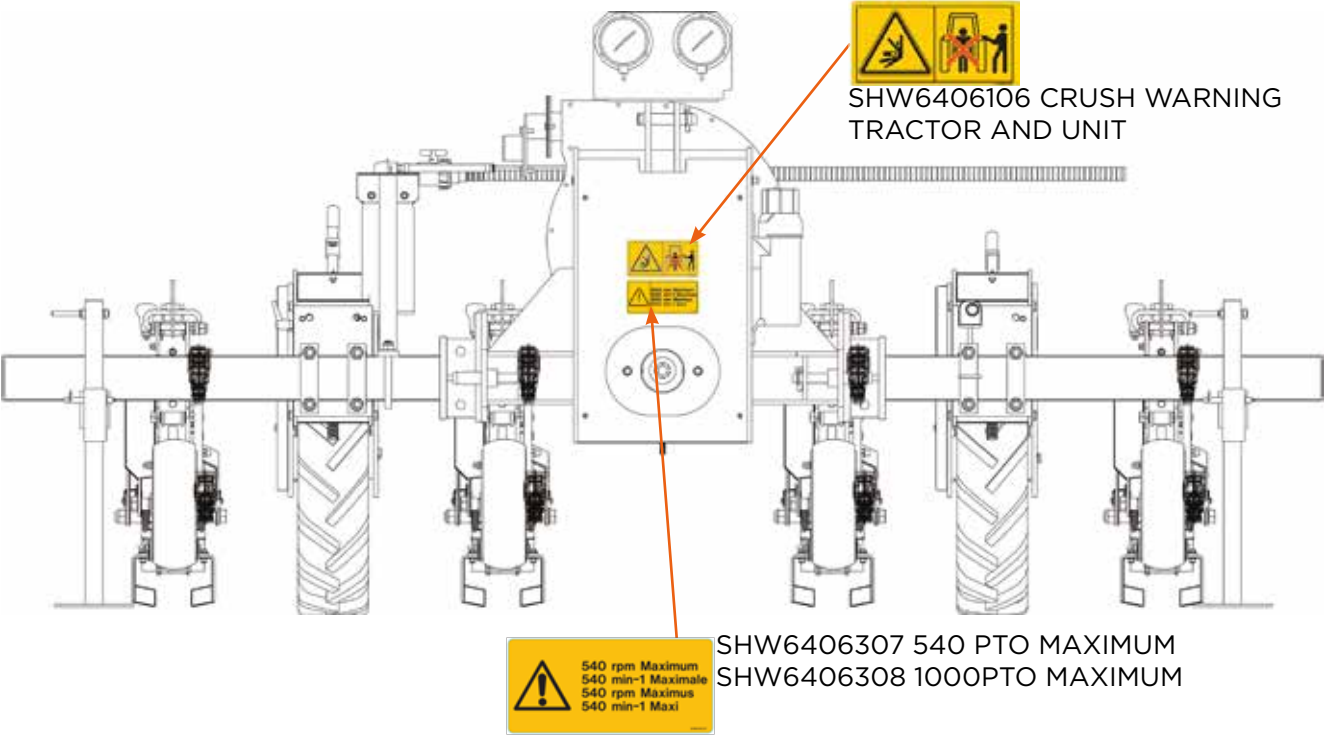

REAR VIEW

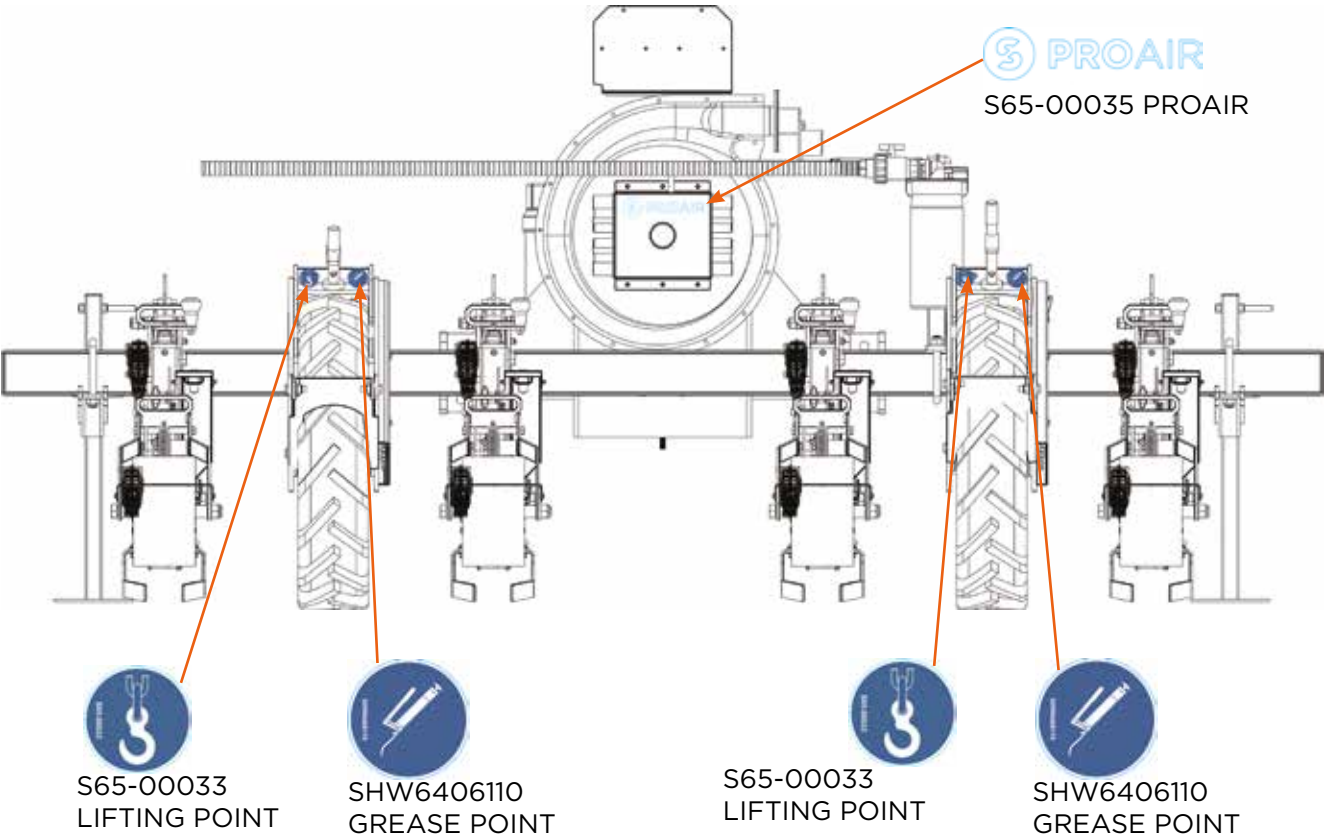

2.0 SAFETY

ROW UNIT LEFT VIEW

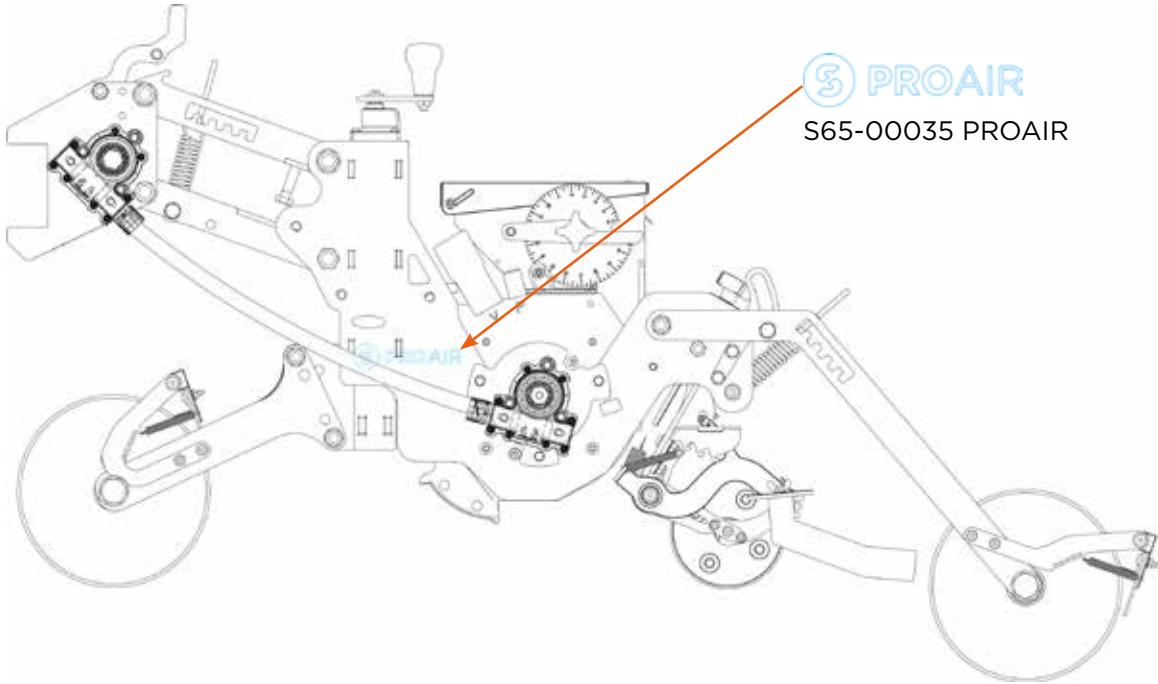

ROW UNIT LEFT VIEW

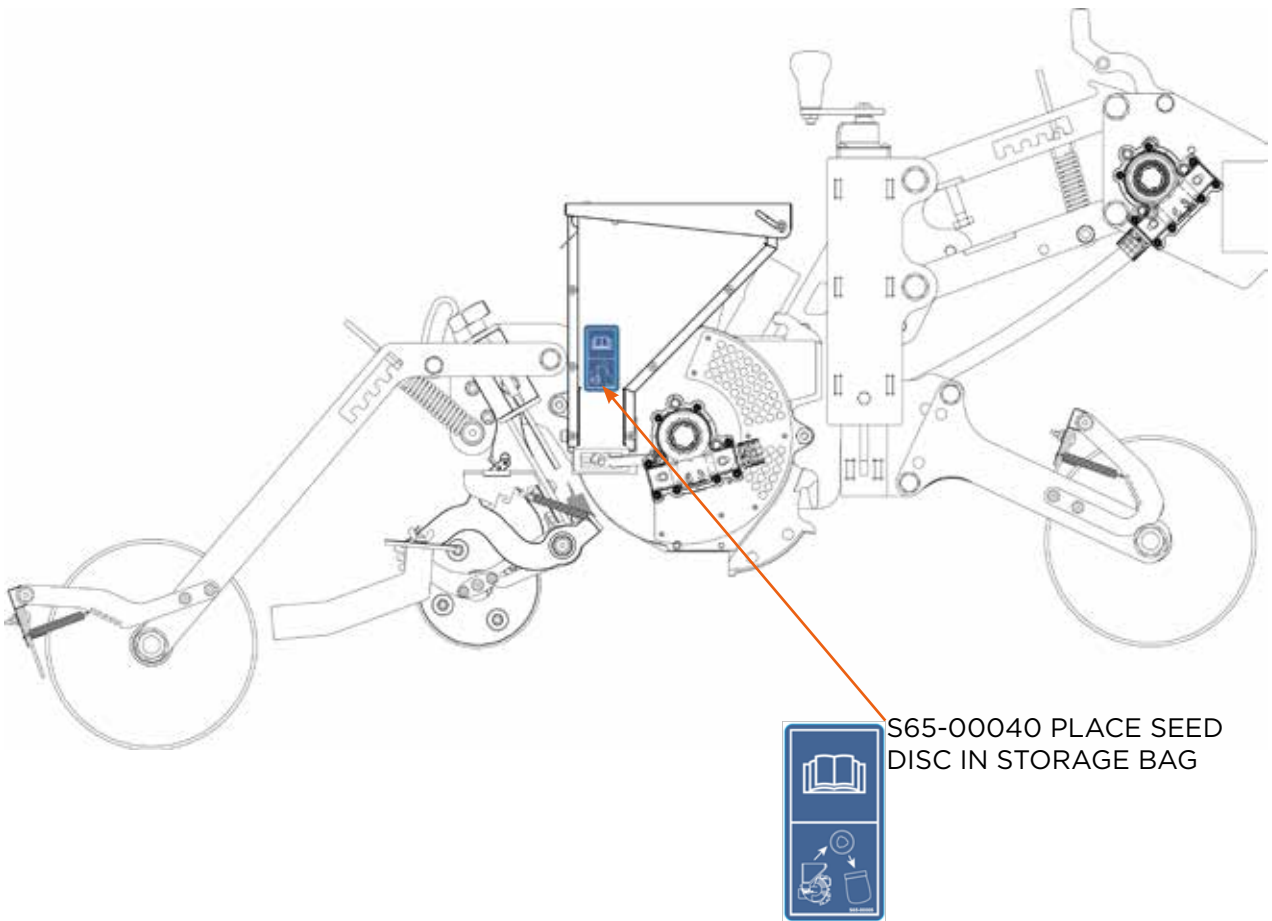

3.0 MOUNTING THE MACHINE

3.1 MOUNTING ONTO THE TRACTOR

Horizontally align the lower guides of the three-point linkage. Ensure that the lower guides are not connected with the tractor via slotted holes in the lifting rods. When in road transport the bottom linkages must be secured at the sides with the help of stabilizers.

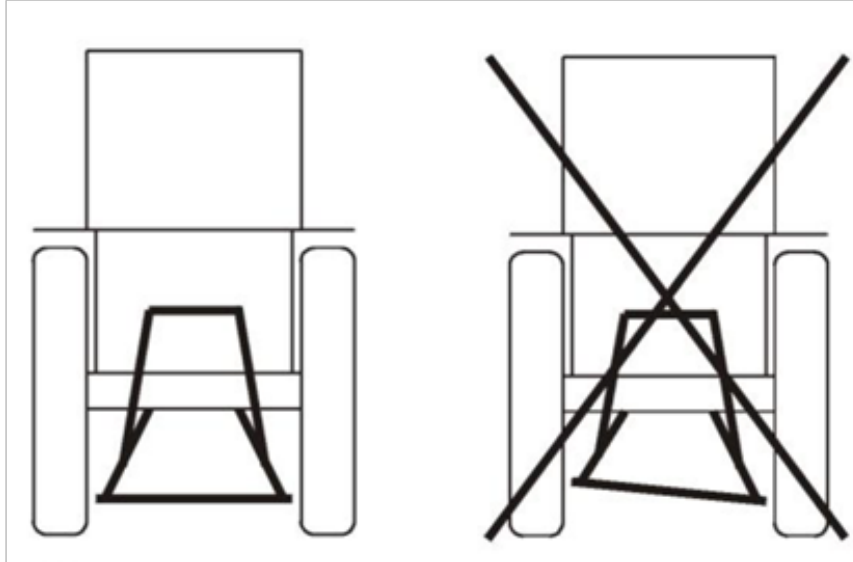

3.2 ENSURING THE TRACTORS STABILITY

Attaching implements to the front and rear power take-offs must not lead to the permissible gross vehicle weight and the maximum permissible axle load or the tyre load carrying capacity of the tractor being exceeded. At least 20% of the dead weight of the tractor must be always taken by the front axle of the tractor.



WARNING!

Risk of crushing! Serious injuries and death possible!

People standing between the tractor and the machine while its being attached are at risk of injury.

- Ensure tractor operator is competent. Check tractor operator manual if required.
- Only enter the area between the tractor and the machine when the tractor is switched off, the parking brake is applied and the keys have been taken out of the ignition.



DANGER!

Accident Risk! Serious injuries and death possible!

The weight of the fully mounted machine can have a big effect on the tractors manoeuvrability and stability!

- A stability assessment must be carried out prior to attachment of the machine.
- Adhere to the permissible axle loads, tyre load carrying capacities and minimum ballast weights.

3.0 MOUNTING THE MACHINE

3.3 PRELIMINARY CHECKS

Before mounting the machine, these checks must have been carried out by either following the calculations below or by having weighed the tractor and implement combination.

INDEX	DESCRIPTION	SOURCE
TL (Kg)	Dead weight of the tractor	Refer to the tractor operator manual
TV (Kg)	Front axle load of the empty tractor	
TH (Kg)	Rear axle load of the empty tractor	
GH (Kg)	Total weight of the rear mounted implement (rear ballast)	Refer to VIN plate
GV (Kg)	Total weight of the front mounted implement (front ballast)	Refer to front mounted implement manual
a (m)	Distance between the centre of gravity of the front mounted implement and centre of front axle	Refer to tractor operator manual and front mounted implement manual
a1 (m)	Distance between the centre of the front axle and the centre of the lower linkage ball	Refer to tractors operator manual or measure
a2 (m)	Distance between the centre of the lower linkage ball and the centre of gravity of the front mounted implement	Refer to the front mounted implement manual
b (m)	Wheel base of tractor	Refer to the tractor operator manual
c (m)	Distance between the centre of the rear axle and the lower linkage ball	
d (m)	Distance between the centre of the lower linkage ball and the centre of gravity of the rear mounted implement	

3.0 MOUNTING THE MACHINE

3.4 LOAD CALCULATIONS

The calculation for the minimum ballast for the front of the tractor can be calculated from the equation below:

$$GV_{min} = \frac{GH * (c + d) - TV * b + 0.2 * TL * b}{a + b}$$

The calculation for the minimum ballast for the rear of the tractor can be calculated from the equation below:

$$GH_{min} = \frac{GV * a - TH * b + x * TL * b}{b + c + d}$$

The calculation for the actual front axle load can be calculated from the equation below:

$$TV_{tat} = \frac{GV * (a + b) + TV * b - GH * (c + d)}{b}$$

The calculation for the actual gross weight of the vehicle can be calculated from the equation below:

$$G_{tat} = GV + TL + GH$$

The calculation for the actual rear axle load can be calculated from the equation below:

$$TH_{tat} = G_{tat} - TV_{tat}$$

The tyre load carrying capacity should be found on the tyres side wall/tyre manufacturers documents. This figure needs to be doubled (for two tyres).

	Actual calculated value (kg)	Permissible value according to tractors operator manual (kg)	Double permissible tyre load-carrying capacity (two tyres) (kg)
Minimum ballast front/rear	/	N/A	N/A
Gross vehicle weight			N/A
Front axle load			
Rear axle load			



All calculated values must be smaller than or equal to the permissible values. The minimum ballast weight must be attached to the tractor as an implement or ballast weight.

3.0 MOUNTING THE MACHINE

3.5 CONNECTING THE MACHINE TO THE TRACTOR

These machines are attached to the tractor via the 3 point linkage. The drill headstocks have the option of fitting the drill to a Category 2 and 3 linkage on the tractor.

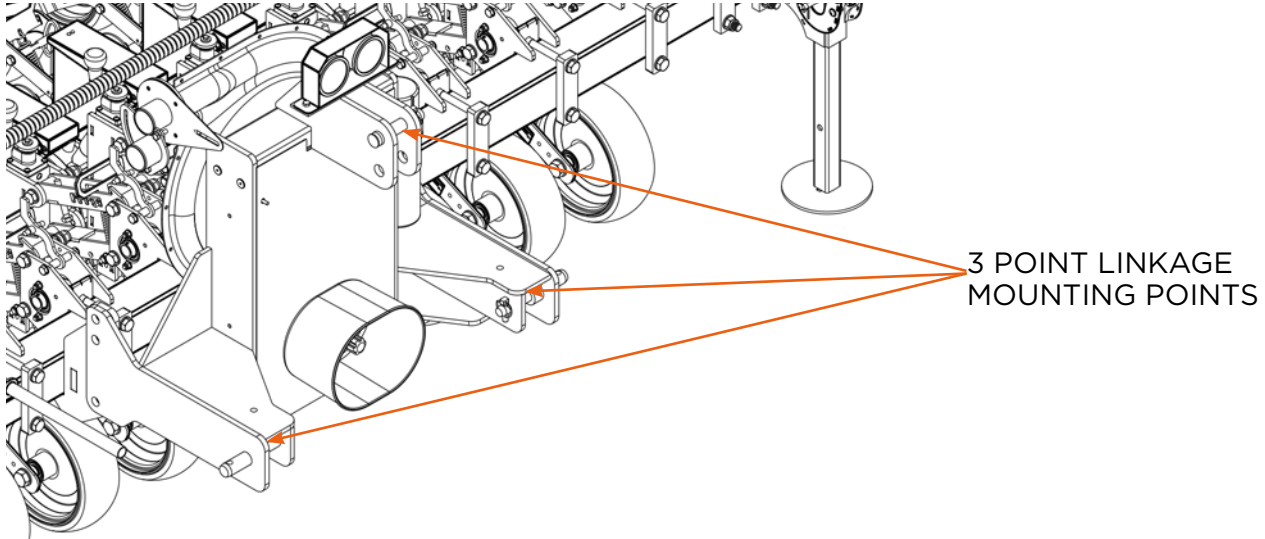

WARNING!

Risk of crushing! Serious and fatal injuries possible!

People standing between the tractor and the machine during coupling are subjected to a risk of injury.

- Ensure tractor operator is competent. Check tractor operator manual if required.
 - Only enter the area between the tractor and the machine when the tractor is switched off, the parking brake is applied and the keys have been taken out of the ignition.
- Before connecting the machine to the tractor, switch off the tractor, apply the parking brake and remove the ignition key.
- Push the lower link arm balls into the lower link pin, ensure the guide ball inner diameter matches the diameter of the lower link pin.
- Secure the lower guide ball and pin with a linchpin.
- Connect the lower link with the lower link guide shaft of the machine.
- Fold and secure the tractor lower link locks on the tractor.

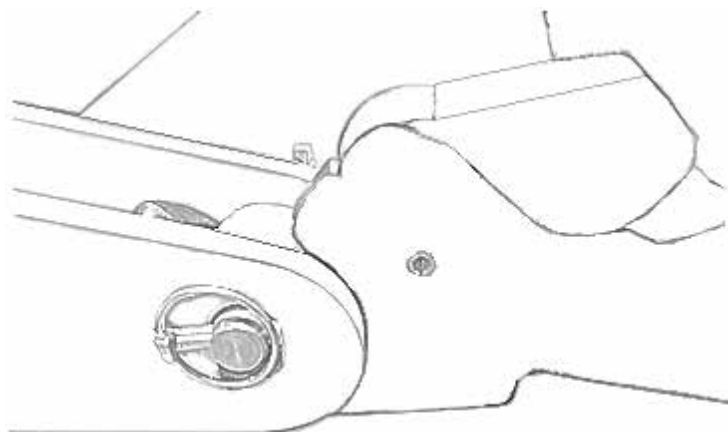

3.0 MOUNTING THE MACHINE

→ Connect the top link with the top link pin and support with a linchpin.

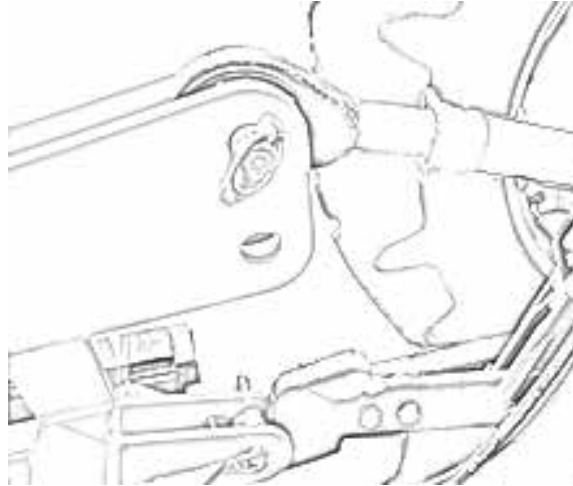

Once the three point linkage is connected proceed to connect any required hydraulic or electrical services to the tractor. When doing so ensure they are routed so as to avoid any pinch or chafing points and will not be damaged during machine operation. Any defective hoses should be replaced immediately.



CAUTION!

The hydraulic system is under high pressure!

Fluids under high pressure can penetrate the skin and cause serious injuries. If this occurs seek medical assistance immediately.

- Ensure care is taken when coupling and un-coupling the tractor services.
- Depressurise the hydraulic system on the machine before un-coupling the hydraulic services.



WARNING!

Unintentionally actuated machine functions may lead to serious or even fatal accidents!

- Before connecting any hydraulic services, ensure the tractors controls have been switched to a neutral position.



Ensure the hydraulic hoses are connected to the correct ports on the tractor. Failure to do this may result in the hydraulic services not operating correctly.

3.0 MOUNTING THE MACHINE

3.6 MOVING PARKING STANDS TO TRANSPORT POSITION

**CAUTION!**

Risk of crushing! Injuries possible!

Risk of injury from a manually movable machine part.

- When operating the movable part, ensure the operator is aware of any pinch and shear points.

The parking stands hold the machine in the attached position when it is parked. After attaching the machine to the tractor the parking stand must be raised to their transport position.

See step-by-step guide to doing this procedure below:

- Lift the machine off the ground using the tractors 3 point linkage.
- Turn off the tractor, apply the parking brake and remove the ignition key.
- Remove the linchpin, remove pin from mounting foot.
- Lift mounting foot upwards until the last hole in the mounting foot locates with the fixed parking stand mounting. Install the pin back into the parking stand through the fixing hole and install the linchpin.
- Make sure this is applied to all parking stands fitted to the machine.

4.0 ROAD TRAVEL

4.1 GENERAL SAFETY REGULATIONS FOR ROAD TRAVEL



The provisions of the road traffic regulations of other countries may vary. The requirements of the respective country shall apply where these differ from those of the manufacturer.



Vehicle owners and drivers are responsible for observing the statutory national road traffic provisions.



Never exceed the permissible axle loads and total weights of the tractor. Observe and adhere to the legal and technical limits of the tractor!



Driving, steering, and braking characteristics are influenced by any mounted or attached machinery and ballast weights. Therefore, pay attention to adequate steering and braking ability.



WARNING!

Risk of accident on dirty and slippery roads!

Soil forms a slippery coating on road surfaces and can jeopardise the safety of other road users.

- Clean the machine before travelling on the road.



DANGER!

Risk of accidents by unsecured machines!

A machine that is not in a secured transport position may not be used in public road traffic. There can be serious injuries in the event of an accident.

- Only move the machine on public roads when all guarding equipment has been attached and is in the correct (protective) position!



DANGER!

Poor visibility can lead to serious accidents!

Driving on the road with heavily soiled cabin windows exposes the driver and other persons to danger.

- Make sure the vehicle has good all-round visibility!



WARNING!

Handling tractors requires special safety measures to be taken.

The notes in the operating instructions of the tractor manufacturer must therefore always be read and followed. Non-compliance may lead to damage to the machine as well as injuries due to accidents.

- Follow the operating instructions of the tractor manufacturer!



DANGER!

Excessive driving speeds can lead to serious accidents!

Driving at excessive speeds exposes the driver and other persons to danger.

- Always drive at an adequate speed. Observe permissible maximum speed!



DANGER!

Accident risk! Serious injuries and death possible!

Persons riding on the machine can be seriously injured or fall off the machine and may be run over.

- It is forbidden for persons to ride on the machine!
- It is forbidden to transport any objects on the machine!

4.0 ROAD TRAVEL

4.2 ROW UNIT TRANSPORT POSITION

When transporting the drill over long distances it may be necessary to latch the units out of work to protect the units from moving on their parallel links. To latch the individual units follow the steps below:

- Lower the drill to the ground and switch off the tractor.
- Position the latch handle supplied into the location points (A) on the image below.
- With the latch flipped over to rest on the parallel link lift the row unit until the latch engages.
- Repeat steps for the remaining row units.



It maybe necessary to remove the vacuum and pressure hoses temporarily to aid in locating the handle.



CAUTION!

Risk of crushing! Injuries possible!

Risk of injury on articulated and moveable machine parts.

- When moving or folding moveable or swivelling parts, pay attention to pinch and shear points!

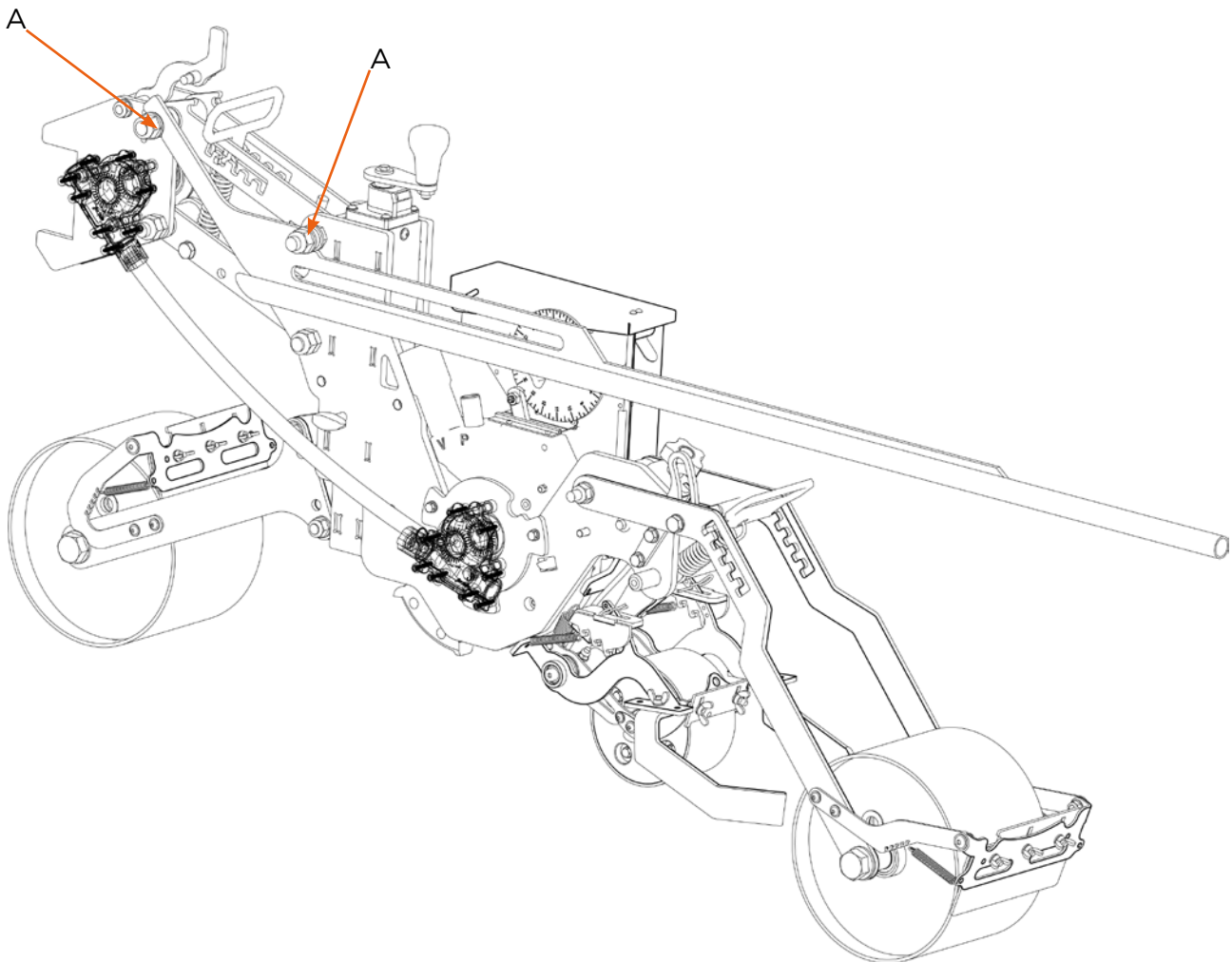

4.0 ROAD TRAVEL

4.3 FOLDING THE MACHINE FOR TRANSPORT

Folding frame machines must be put into the folded position for road transport. On some high density machine configurations it may be necessary to latch units out of work to allow folding as indicated by additional warning stickers on the frame. All additional equipment such as marker arms should also be put into the transport position and all safety mechanical locking devices fitted securely before road transport.



Before commencing a journey, the height of the machine in transport position must be checked. The height may not exceed the national provisions regarding the participation in public road traffic! Adapt the tractor attachment or hydraulic lifting at the tractor where necessary.



WARNING!

Risk of injury! Serious injuries and death possible!

Components jutting into oncoming traffic can cause accidents during road travel and jeopardise other road users!

- Completely fold in the main frame before travelling on the road!



CAUTION!

Risk of crushing! Injuries possible!

Danger of injury on swivelling machine parts!

- Pay attention to pinch and shear points when unfolding and folding the machine!
- Observe the seeding units' pivoting radius and instruct all persons to leave the danger zone!



WARNING!

Risk of injury! Serious injuries and death possible!

Components jutting into oncoming traffic can cause accidents during road travel and jeopardise other road users!

- Bring the lane marker to transport position before travelling on roads!



DANGER!

Danger of life from electric current!

Danger of life by contact with high voltage lines.

- Note the machine's transport height.
- Keep an adequate safety distance to high voltage lines. Never carry out the folding operation in the vicinity of high-voltage lines.

4.0 ROAD TRAVEL

4.4 UNCOUPLING THE HYDRAULIC PRESSURE PIPE

When driving on public roads, no machine functions must be operated. To rule out any accidental actuation, disconnect the pressure pipe from the tractor.

- Depressurise the hydraulic pipes using the corresponding spool valve on the tractor.
- Disconnect the pipes from the tractor.

**WARNING!**

Risk of injury! Serious injuries and death possible!

Hydraulic systems accidentally activated during transport can present a risk of accident and jeopardise other road users.

- Disconnect the hydraulic pressure pipe from the tractor prior to road travel!

**WARNING!**

Risk of injury! Serious injuries and death possible!

Fluids escaping under high pressure can penetrate the skin and cause serious injuries. If such injuries occur, consult a doctor immediately as otherwise there is a risk of serious infection.

- Depressurise the hydraulic system of the tractor.
- Take care when uncoupling hydraulic lines.

**CAUTION!**

Risk of burns! Injuries possible!

Take care when working on a hot hydraulic system. Hot hydraulic oil can cause serious skin burns!

- Let the hydraulic system cool down before you start working on it and wear protective gloves.

4.0 ROAD TRAVEL

4.5 CHECKING THE LIGHTING INSTALLATION

Check the lighting installation before every trip for damage, function and cleanliness!



WARNING!

A defective lighting installation jeopardises traffic safety!

Machines with defective lighting installation can lead to serious accidents because signalling was not possible.

- Check the lighting installation before every trip!
- Immediately replace defective bulbs and lens. Observe specifications!

4.6 LIFTING THE MACHINE

Before driving on public roads, the machine must be lifted out of work on the tractor's three point linkage. So as not to exceed the maximum permissible transport height, the machine may only be lifted so far that the distance (A) between the underside of the frame tube and the ground does not exceed 1000 mm.

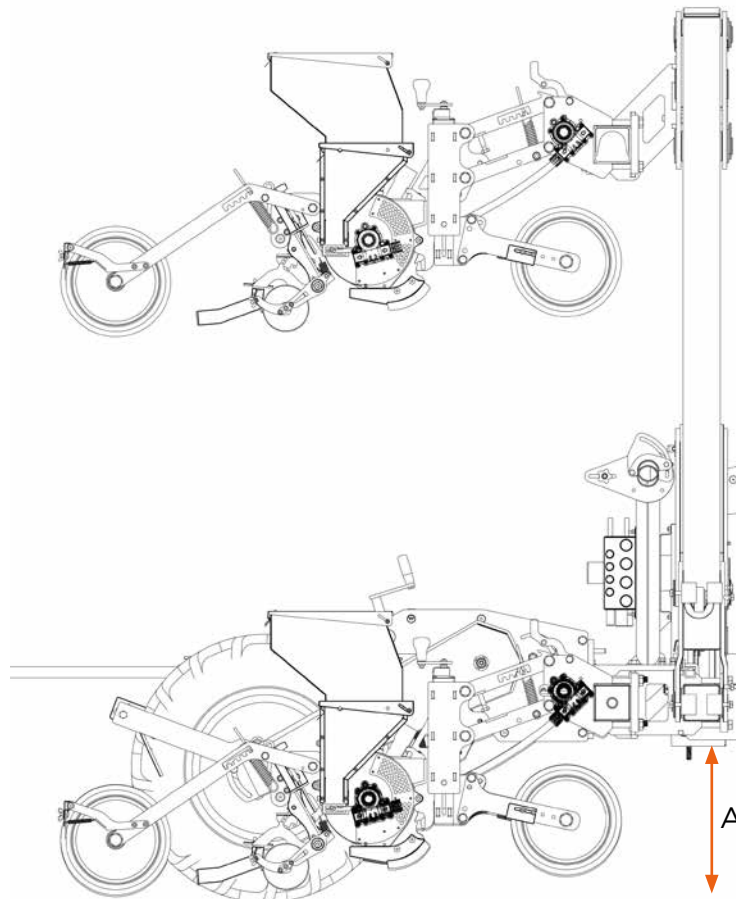

Prior to transporting the machine, fasten the lateral locking device of the tractor's lower guide so that the machine cannot swing back and forth whilst on the road.

5.0 PARTS OVERVIEW

5.1 METERING UNIT OVERVIEW

5.1.1 HOPPER SIDE

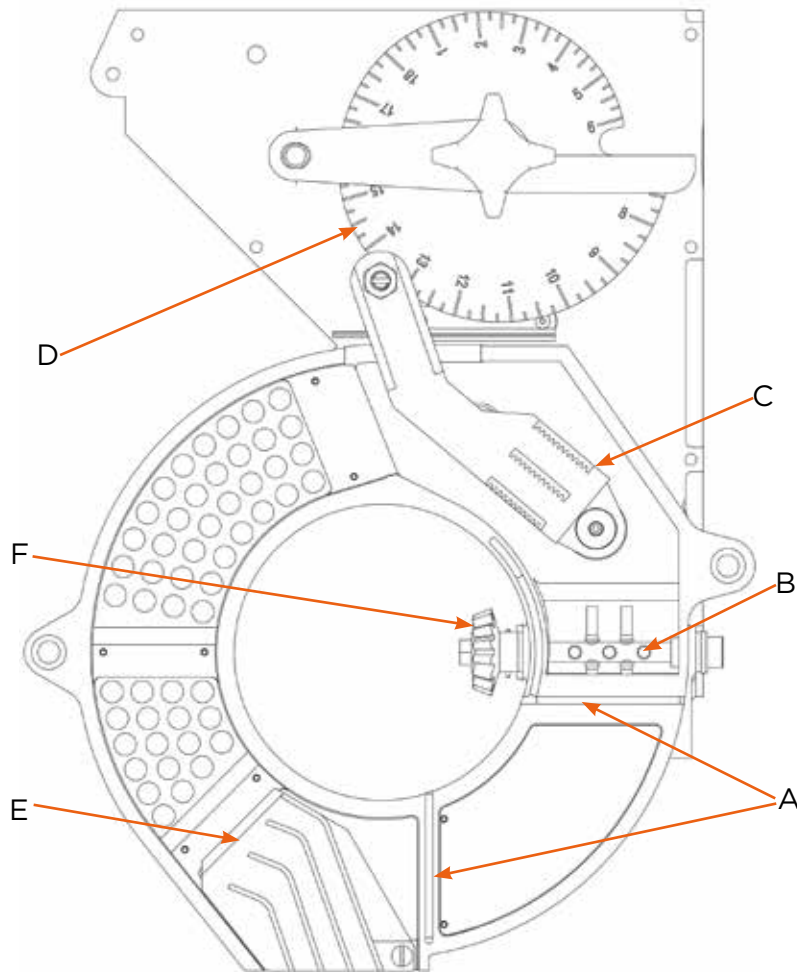

- A. Felts - Creates a 'soft seal' against the seed disc to firstly stop small seed leaking out of the seed chamber and secondly to remove any coating/residue that may be present on the disc face.
- B. Agitator - Keeps the seed 'moving' and prevents it from bridging in the seed chamber. The type of agitator depends on what type of seed is being planted.
- C. Singulator - When calibrated the singulator reduces the amount of 'doubles' per hole on the seed disc. Different singulators are available depending on what seed is being planted.
- D. Singulator cam - Used to help the operator calibrate the metering unit.
- E. Seed splitter - Guides the individual lines on the seed disc down to coulter chute.
- F. Pinion gear - Driven by the crown wheel on the turntable which in turn drives the agitator.

5.0 PARTS OVERVIEW

5.1.2 DRIVE SIDE

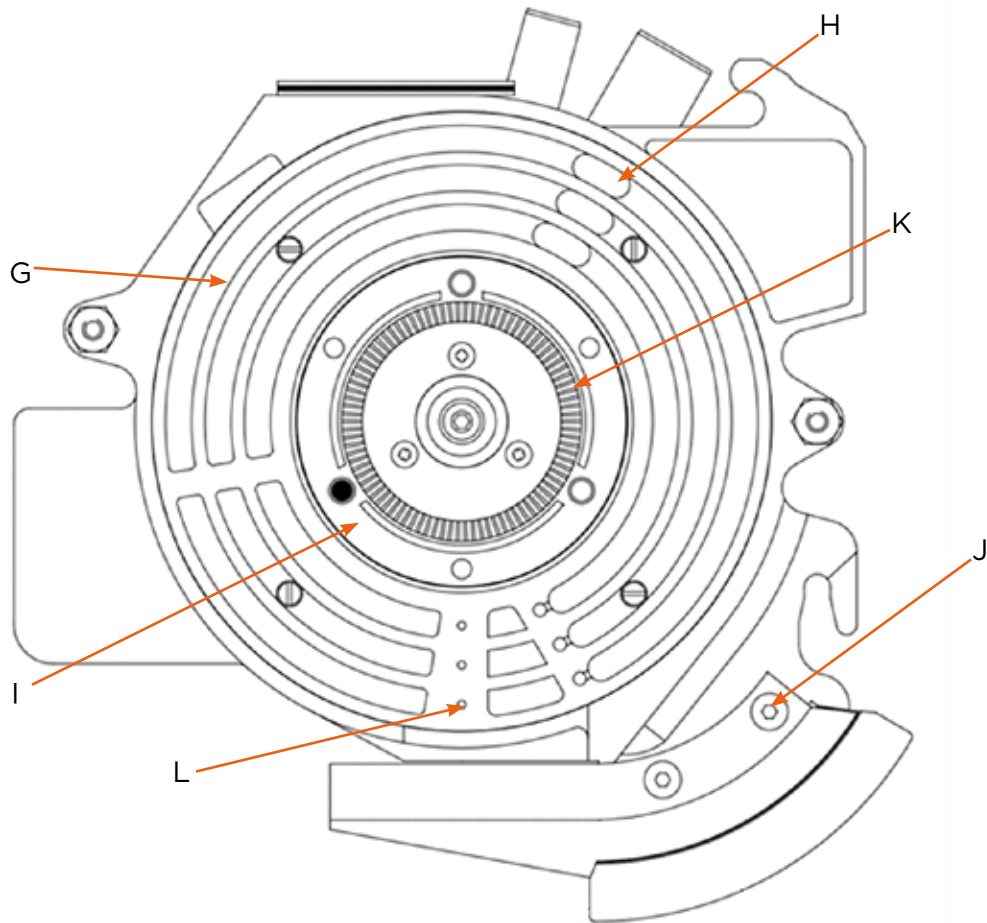

- G. Gallery block - A sacrificial plastic block that forms an air tight seal against the seed disc. A key feature of the Stanhay metering unit is that the gallery block precisely applies vacuum behind each line of the seed disc.
- H. Vacuum channel and inlet - This channel allows a vacuum airflow behind the disc. This vacuum is used to suck the seed against face of the disc.
- I. Turntable - The turntable is connected to the drive sprocket on the reverse side of the casting and contains three magnets and dowels that are used to locate and rotate the disc.
- J. Coultter connection - Two holes at the bottom of the casting make changing coulters easy and ensures that the outlets on the chute align with the respective outlet on the seed splitter.
- K. Crownwheel - Attached to the turntable, the crownwheel is used to drive the pinion on the agitator.
- L. Pressure outlet - Once the disc has past the seed splitter a small jet of pressure is then applied to the holes of the seed disc from the outlet on the gallery block.

5.0 PARTS OVERVIEW

5.2 ROW UNIT OVERVIEW

- A. Adjustable row unit down force handle.
- B. Adjustable rear wheel down force handle.
- C. Two position adjustable front wheel.
- D. Depth control adjustment handle.
- E. Sealed maintenance free flexible drive shaft.
- F. Metering unit.
- G. Seed press wheels
- H. Wheel scrapers.
- I. Latch up handle.
- J. Drag/ arm coverer.
- K. Parallel links.
- L. Coulter

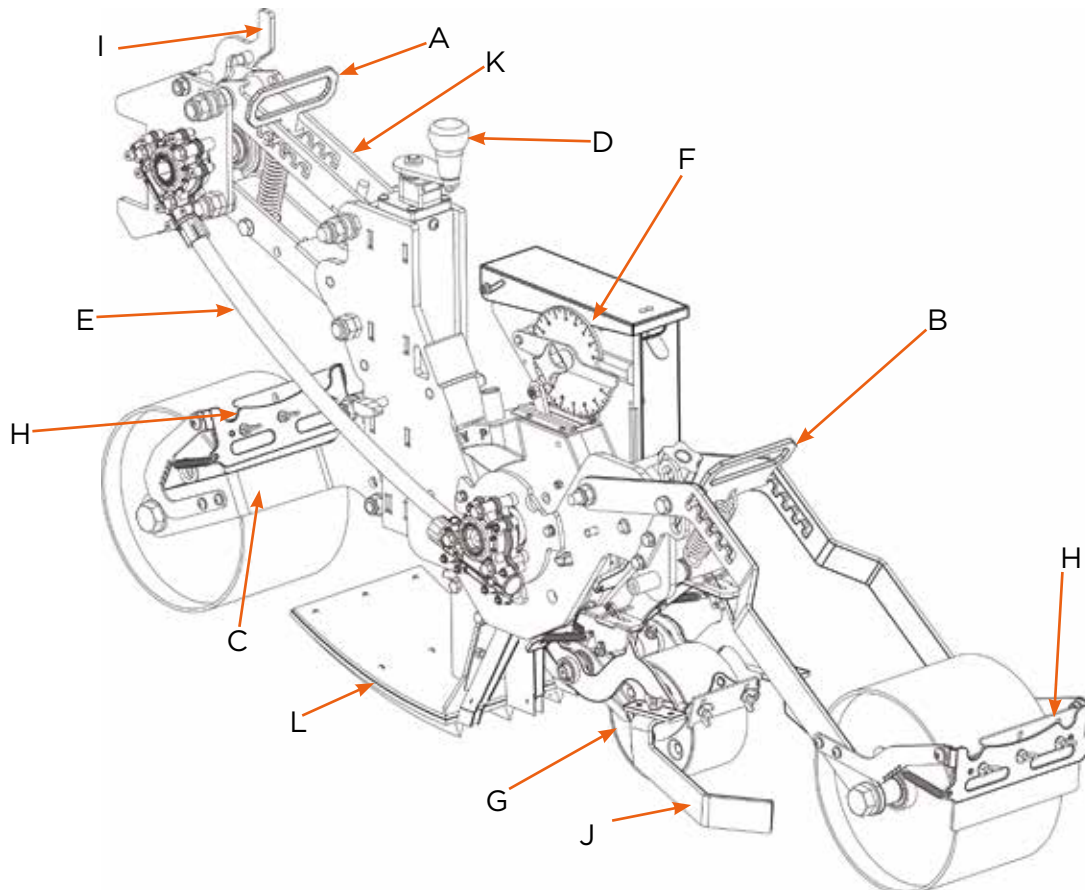

5.0 PARTS OVERVIEW

5.3 FAN OVERVIEW

There are 2 types of fan currently available in the Stanhay range; these are 26 and 17 rib, the former is used for drill configurations over 12 rows or when planting heavy/large seed, the latter being used on drills up to 12 rows or when using smaller or lighter seed. Normally driven by the tractor PTO however both fans can be retrofitted with a hydraulic drive system operated via a spool valve.

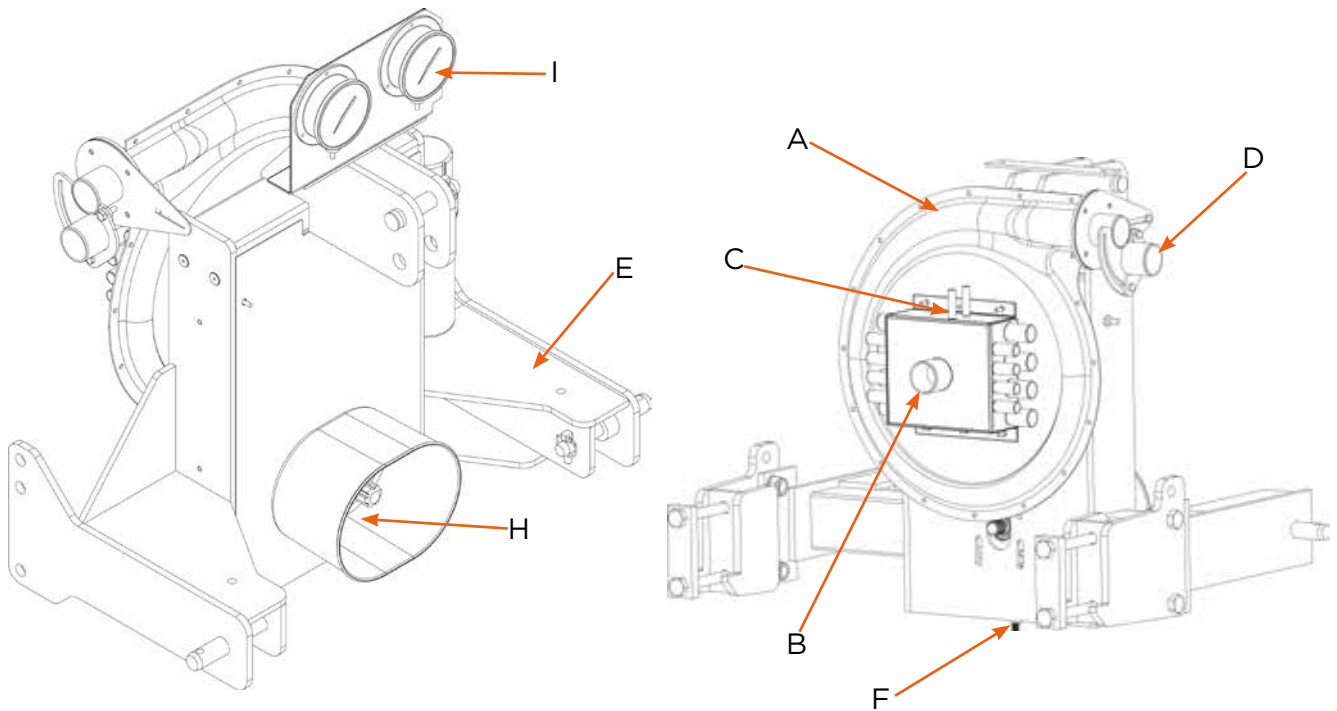

Both fans operate in exactly the same way and are compatible with the folding frame.

- A. Fan casing.
- B. Manifold - the manifold provides the outlet for the vacuum and pressure ports, a number of manifold options are available depending on the size of drill.
- C. Gauge outlets - the outlet is connected to the fan gauges via an 8mm pipe and allows the operator to see how much vacuum/pressure is flowing through the manifold.
- D. Vacuum and pressure controls - these allow the operator to adjust the flow of vacuum or pressure to the metering units.
- E. Headstock - in normal operation fans are mounted on a tractor headstock which is available in cat 2 or 3. Alternatively fans can be purchased as an individual unit for remote mounting On a custom machine.
- F. Belt tensioner - used for tensioning the fan drive belt.
- G. Dust release hole (not shown) - each fan manifold has an opening at the bottom to release any dust/debris that is sucked through the vacuum pipes.
- H. PTO stub - the 26 rib fan is available in either 540 or 1000 PTO configuration. The fan still operates in exactly the same way as the 540 fan but the impeller shaft and the length of drive belt are different.
- I. Vacuum and pressure gauges - allows the operator to see the vacuum and pressure settings on the fan.

5.0 PARTS OVERVIEW

5.4 LANDWHEEL OVERVIEW

- A. Wheel 6.00x16 - provides drive.
- B. Jack screw - adjusts the landwheel height.
- C. Drive chain - drives the sprockets in the gearbox.
- D. Sprocket cluster - contains a 22t, 21t, 20t, 19t, 18t, 17t, 16t and 15t sprocket. These are used to help set the gear ratios.
- E. Tensioner handle - tensions the chain inside the gearbox.
- F. Primary drive sprocket - either a 24 or 40t. Used on the initial drive from the landwheel.
- G. Final drive sprocket - 2 sliding double sprockets; 24t/17t and a 13t/11t. Provide the final drive to the hex shaft.
- H. Scraper - keeps the tyre of the landwheel clean
- I. Jockey - used for tensioning the external drive chain.
- J. Sprung loaded landwheel - on wider drill set ups it maybe necessary to use a sprung loaded landwheel in order to maintain a constant drive on the outside units; this is particularly important on undulating ground where standard 'fixed' landwheels may lose drive and therefore drive to the units. A sprung loaded landwheel conversion kit is available for standard landwheels.

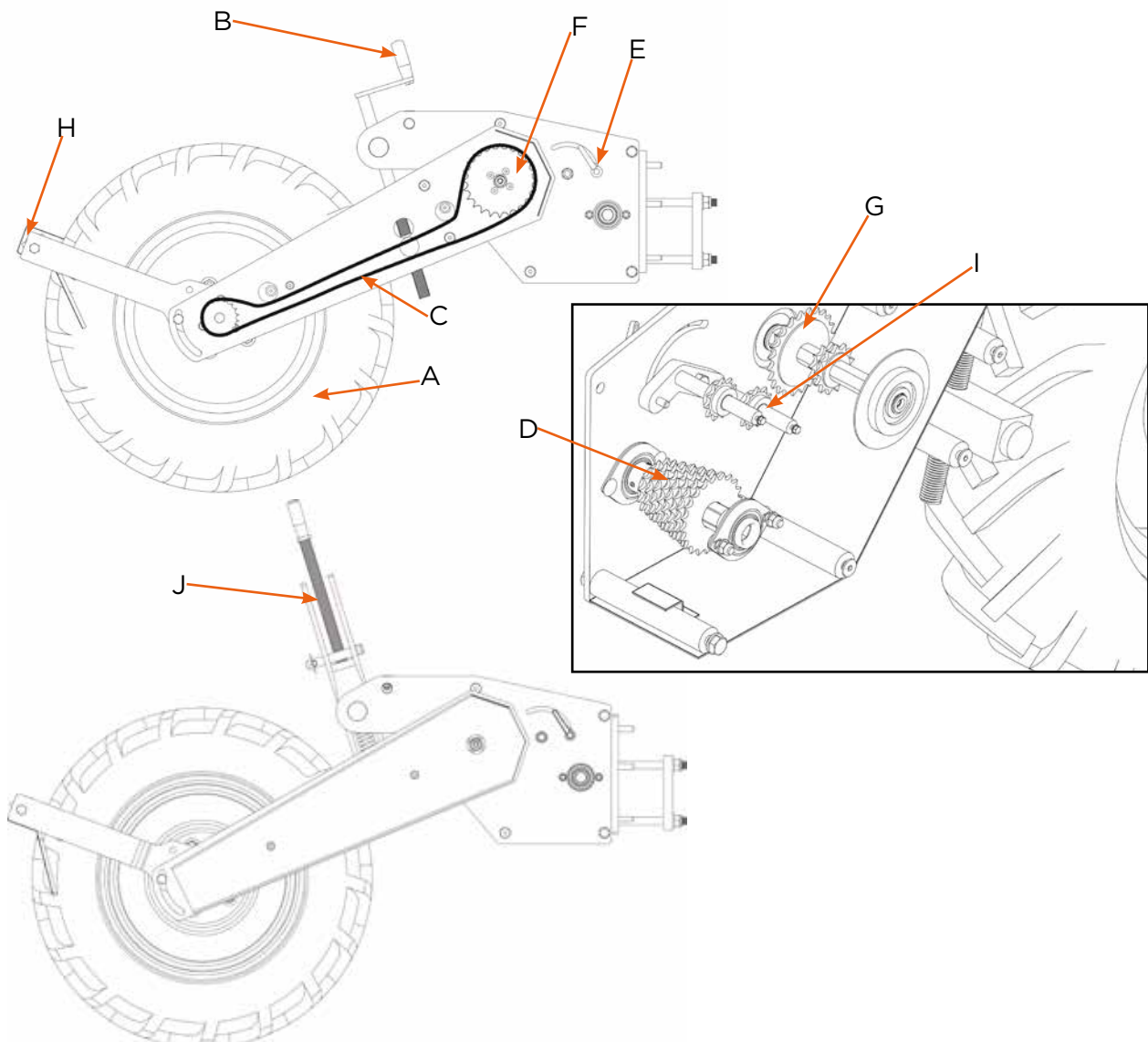

6.0 PRELIMINARY CHECKS

6.1 CHOOSE SEEDING SETTINGS

Using the seed setting guides along with the population calculators and your drill layout identify the recommended settings for the following:

- Seed disc
- Seed disc rpm
- Required seed spacing

6.2 PREPARE METERING UNITS

Check metering unit has the correct options of the following parts fitted:

- Agitator
- Singulator
- Seed splitter/guide
- Seed disc
- Coulter (check this is fitted correctly – refer to coulter fitting section)

6.3 NUMBER METERING UNITS

- Mark identification number on both halves of each metering unit and on each singulator.
- Singulators are factory calibrated to ensure all units perform similarly, they **MUST** remain fitted to the units as supplied.

6.4 CHECK ROW UNITS

Raise machine off the ground, then check:

- Wheels: check all wheels rotate: check adjustment of scrapers and cleaners.
- Pivots: check nuts and bolts, are tight: check chassis will pivot freely.
- Clod deflectors (if fitted): check that blade slides freely in track/ linkage operates freely - then pin out of work.

6.5 CHECK VACUUM & PRESSURE HOSES

Check all hoses are correctly and securely fitted both at manifold and at the metering unit.

- Raise and lower machine to check hoses are not too tight, and are not in contact with shafts, sprockets or chains.
- Unused hose stubs on the fan **MUST** be plugged.

6.0 PRELIMINARY CHECKS

6.6 CHECK DRIVES

Raise machine fully and rotate drive landwheel, ensuring all components rotate freely.

6.7 CHECK HYDRAULICS

Check for correct operation of hydraulic markers or other hydraulic equipment.

6.8 CHECK TYRE PRESSURES

Chain Land Drive Wheels:

- 6.00-16 3.3 bar (48 psi)
- 4.00-16 1.5 bar (22 psi)

6.9 CHECK PTO SHAFT

Fit the PTO drive shaft clutch end to fan unit, cutting to length as required. Try to obtain maximum sliding profile overlap, but without bottoming out, to avoid mechanical damage to the fan unit. The PTO shaft should have end float at all times and this must be checked by fully raising and lowering the machine prior to work. If necessary, shorten the PTO shaft to ensure end float at all times.

- In its working position, the drive shaft must not be extended by more than half the sliding profile overlap available when fully compressed.
- Shorten inner and outer guard tubes equally.
- Shorten sliding profiles by same length as guard tubes.
- Remove all sharp edges and burrs.
- Do not suspend drive shaft from the chain.
- Fit splined PTO shaft coupling securely, secure shaft cover to prevent rotation in use.



For further information see the shaft manufacturers service instructions.



Grease sliding profiles.



Guard chains must be properly fitted.



DANGER!
Risk of injury! Serious injuries and death possible!

- Do not rely on the tractor hydraulics.
- Do not work beneath an un-propped machine.

7.0 SEED DISCS

7.1 CHOOSING THE CORRECT SEED DISC

Choosing the correct seed disc is the single most important item in ensuring good unit performance. When choosing a disc you must select the hole size, this is dependent on seed type and size of which recommendations are made in the seed setting guide or will be determined by a Stanhay representative testing your seed to determine the optimum hole size. The number of holes in the disc and the number of lines planted per row will be dictated by the population and drill layout you have.

The standard designated formats for a seed discs are shown below:

'0.6 x 96 x 3L' '0.8x96/96/96'

7.2 HOLE SIZE

The right hole size for the seed used is imperative to disc performance. An incorrect hole size may cause problems with seed 'pickup'; too small a hole and the seed won't be sucked to the face of the disc or excessive vacuum may be needed. Too big a hole and it will be unlikely that the seed can be singulated effectively.

7.3 NUMBER OF HOLES

The number of holes on each of the disc is relative to seed spacing and forward speed, the more holes in the disc the closer the spacing and a quicker forward speed is achievable. However for better seed spacing accuracy choose the lesser number of holes especially on multi-line drilling.

7.0 SEED DISCS

7.4 DISC LINES

The number and position of the holes on each line of the disc determines where the seed falls through the coulter. A typical 3 line coultter pattern is shown below.

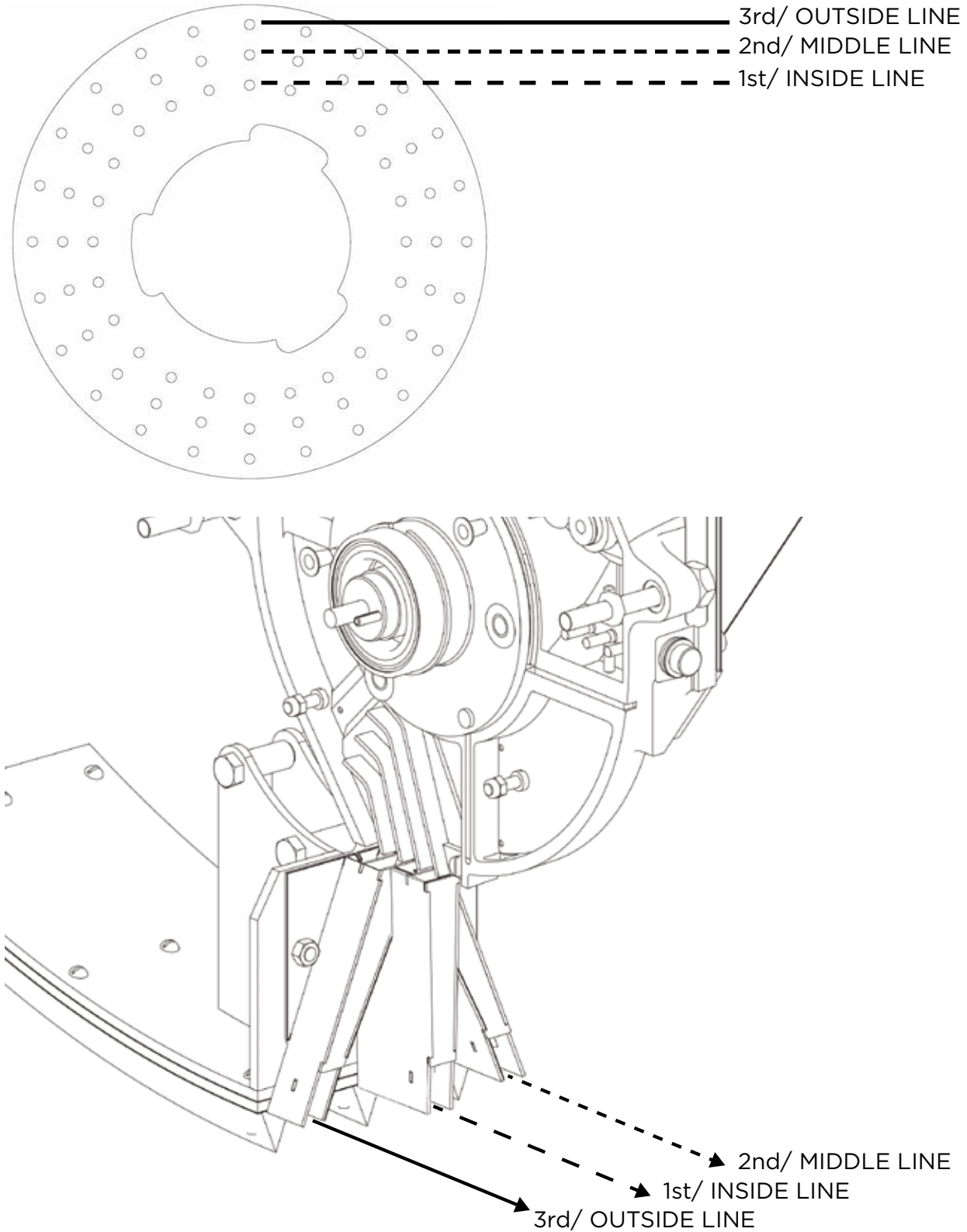

7.0 SEED DISCS

7.5 DISC SPEED

The seed setting guide will give recommendations for the disc speed for different discs, these should be adhered to for optimum performance. As a general rule the slower the disc speed the better the seed spacing particularly with multi-line drilling.

7.6 ADDITIONAL SEED DISC FORMATS

Due to the number of crops and drill systems the Stanhay metering unit can cater for there are also a number of non standard disc formats with a variety of hole arrangements. Below are some designations that may be found on the seed disc descriptions:

7.7 I/S LINE

Inside line. Used when drilling single line through a three line coulters. This will usually be labelled on the seed disc as '0.6x96x1/S Line' for example and will have a single line of holes on the inside PCD of the disc.

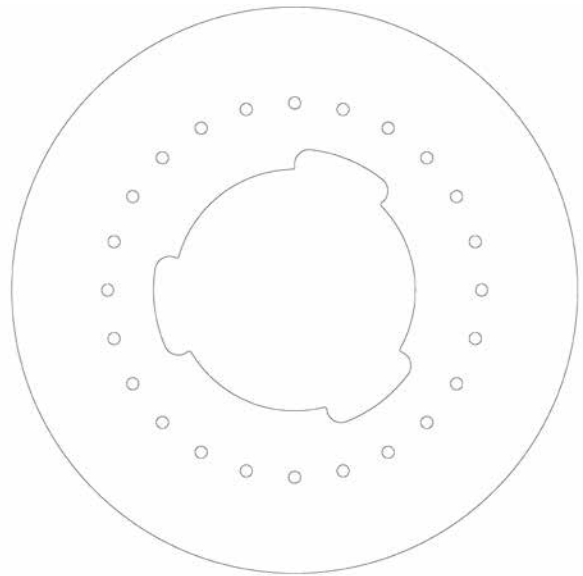

7.8 GRPS

Groups. For planting multiple seeds at a station usually at wide seed spacing seeds and thinned after germination i.e Tomatoes.

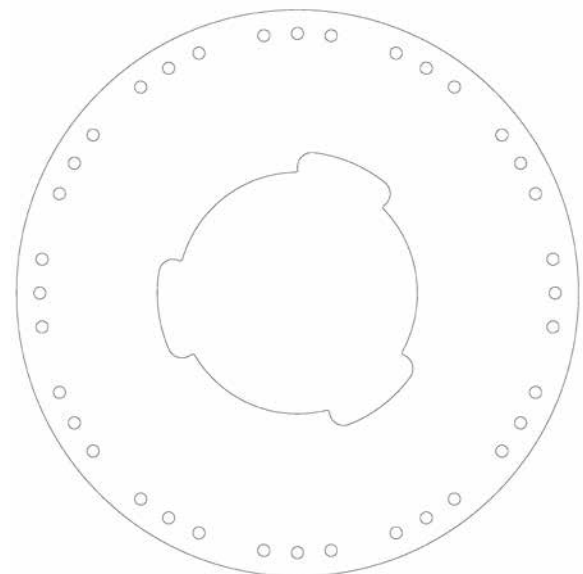

7.0 SEED DISCS

7.9 STAGGERED

The holes on each line are offset to the next line so that the seeds are planted in a staggered arrangement in the soil.

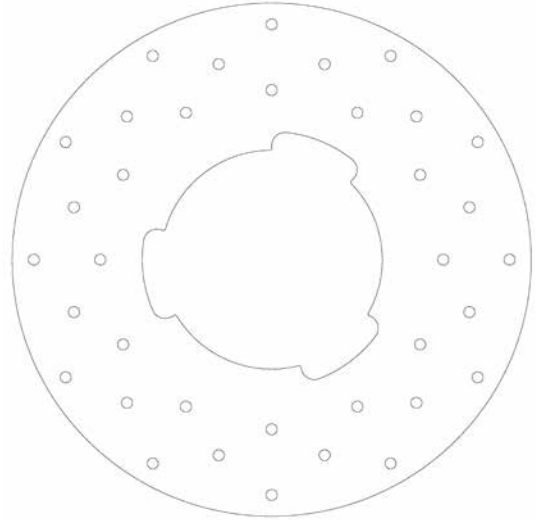

It is also possible to have a different number of holes on each line of the disc. For example 96/96/72 where the central line of a 3 line coultter will plant at 75% of the outer lines.

7.10 SEED DISC CARE

Proper care of seed discs is essential to ensure consistent performance. Follow these guidelines:

- Remember that seed discs are fragile and no attempt should be made to remove a disc from a unit while vacuum is still applied.
- Store in a dry place in the supplied bags checking they are sealed.
- If you suspect the disc is greasy, clean thoroughly with a solvent solution (grease can cause seeds to stick to the surface of the disc).
- Always check all the holes in seed disc are clear of blockage before refitting in the units. This can be done by holding them in front of a light.



If mild steel discs are not stored in the blue plastic bags supplied, or if left unused in a damp environment, corrosion may occur. Slight surface corrosion is not detrimental to the performance of the disc and no attempt should be made to clean off corrosion as this may damage the disc and render it unusable.

8.0 COULTERS

8.1 COULTER RECOMMENDATIONS

DESCRIPTION	RECOMMENDED FOR
Single Line Cast	General Purpose
Single Line Ceramic	Sticky and/or abrasive
Single Line Non-stick Plastic	Sticky/trashy. Drilling depth critical. Non-abrasive soil types.
Shallow Fin Multi-line	Multi-line drilling in stoney/cloddy or stoney seedbeds.
Non-stick Plastic Multi-line	Multi-line drilling in sticky/trashy conditions. Drilling depth critical. Non-abrasive soil types
Deep Fin Multi-line	Multi-line drilling in fine clean seed beds. Minimum soil disturbance

8.0 COULTERS

8.2 FITTING SINGLE LINE COULTER

The coulters tip is clamped to the bottom of the unit body casting between stainless steel clamping plates by two pairs of socket head screws. When fitting, ensure that the vertical rear face of the coulters tip locates firmly against the cut-outs in the clamping plates as shown, to prevent soil entering the seed outlet area.

When changing from 2 or 3 line coulters to single line, remove the seed guide from the hopper side of the metering unit to allow seed to fall centrally to the furrow bottom.

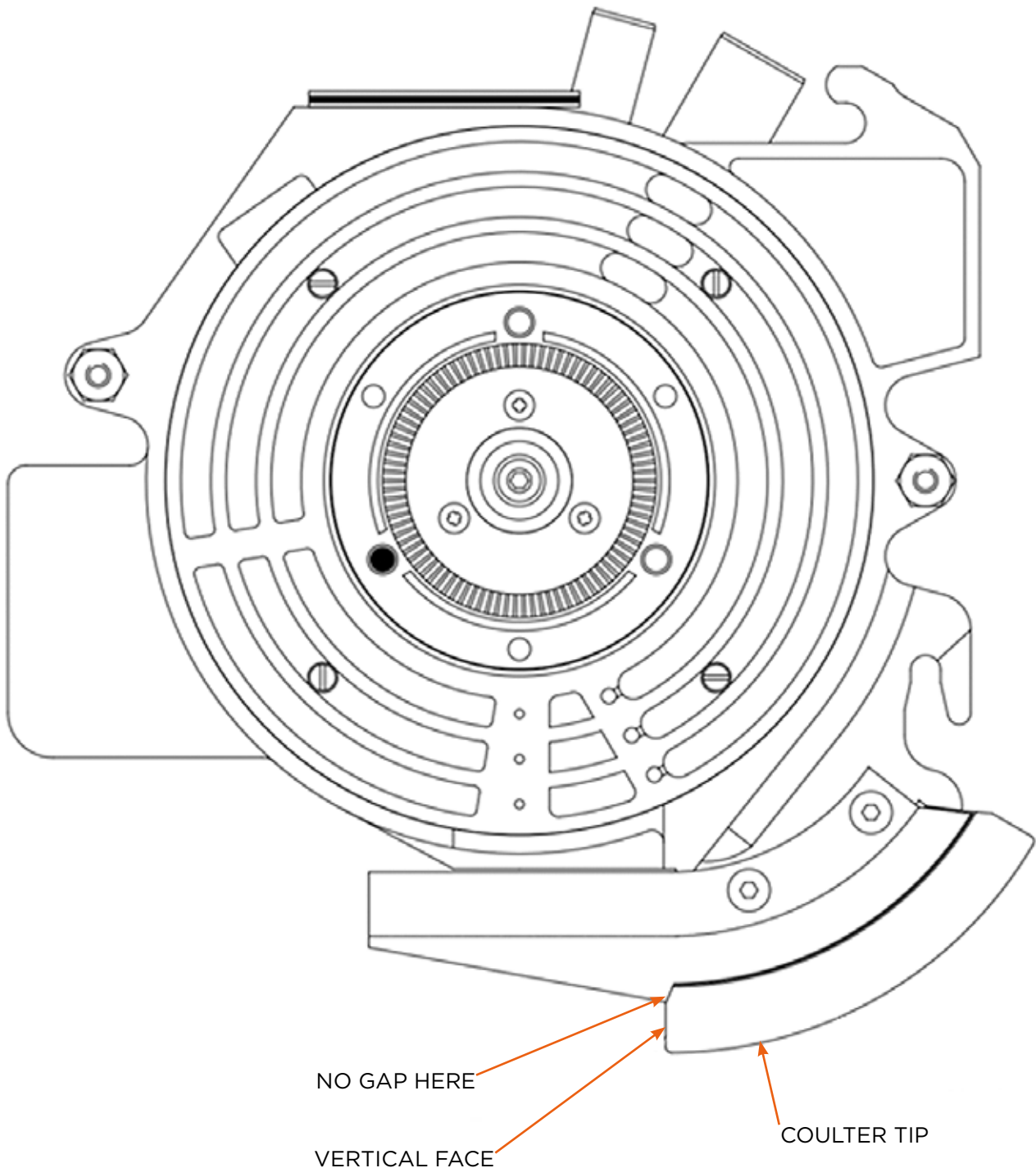

8.0 COULTERS

8.3 FITTING 2/3 LINE COULTER & SEED GUIDE

- Fit coulters over the bottom of the unit body casting, align the holes (A) and retain with the fasteners supplied.
- Pivot the rear of the coulters upwards to achieve the minimum gap (B) between the underside of the body casting and the top of the seed chutes at the rear of the coulters, 1mm maximum.
- Holding the coulters in position, tighten the fasteners until the coulters are firmly clamped in-place.
- Fit seed guide (C) to the hopper side of the metering unit locating the dowel on the guide through the holes in the casting.
- Attach using the screw and self-locking nut (D) with the nut on the outside, as shown.
- Finally, fit the self-tapping screw (E) through the hole in the Perspex window into the boss moulded onto the guide.



When the hopper side is fitted to the body, check that the bottom of the seed guides (F) line up with their respective coulters seed chutes.





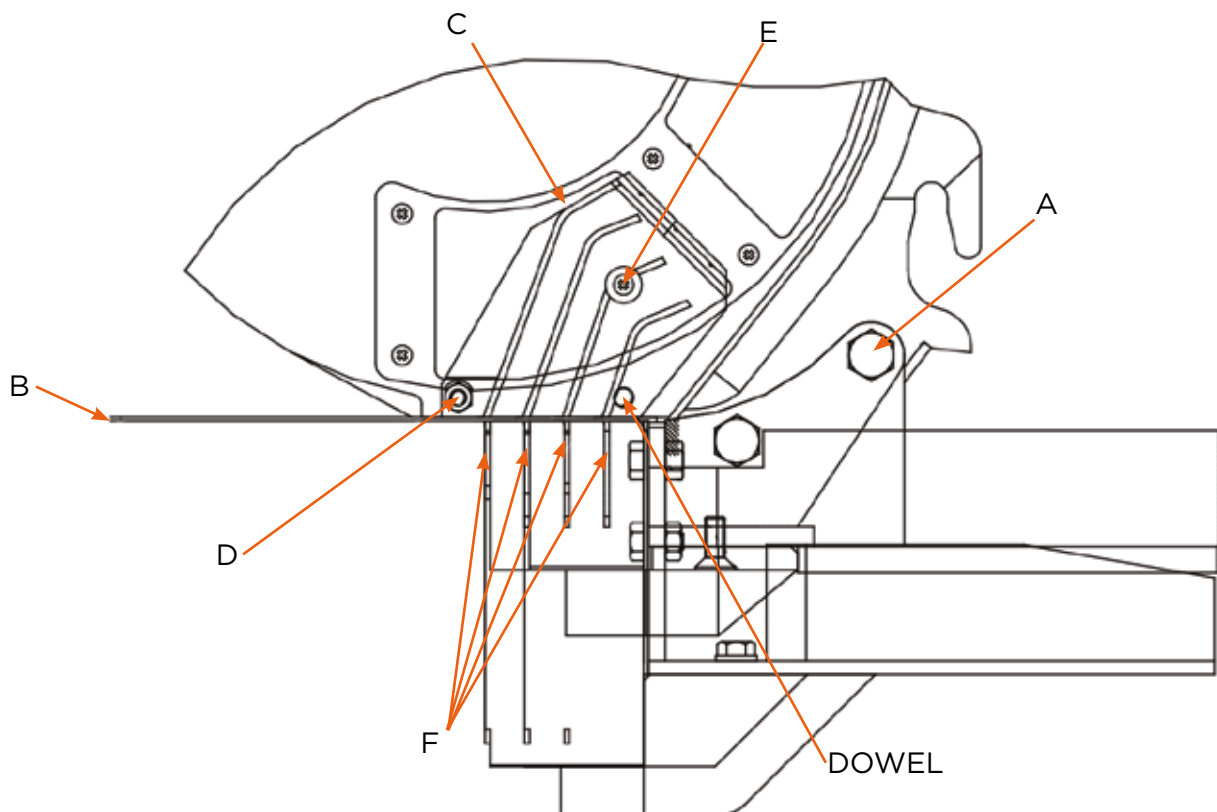



The seed guide is fragile and will be damaged if the fasteners are over-tightened.



8.0 COULTERS

8.4 FITTING RIB PACKERS ON SKI COULTERS

Up to 2 rib packers can be fitted per rib on a ski coulters to increase seeding depth. Each rib increases maximum achievable depth by 6mm.

PLASTIC		2286008 1 INCH X NO.8 ROUND HEAD SCREW -USE WITH NO PACKERS
CAST		2309015 M4 X 16 SET SCREW
PLASTIC		2286009 1.1/4 INCH X NO.8 ROUND HEAD SCREW -USE WITH ONE PACKER
CAST		2309017 M4 X 25 SET SCREW
PLASTIC		2286010 1.1/2 INCH X NO.8 ROUND HEAD SCREW -USE WITH TWO PACKERS
CAST		2309018 M4 X 30 SET SCREW

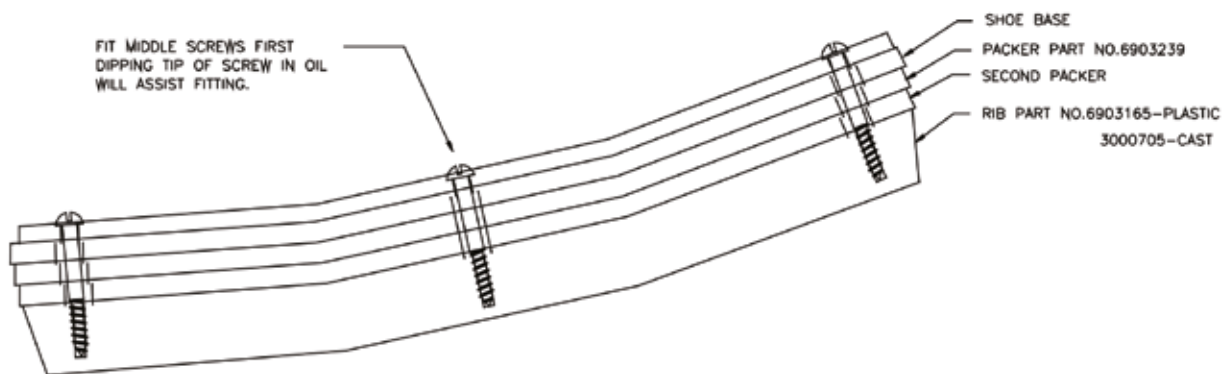

FITTING RIB PACKERS TO
NON-STICK SKI SHOES

9.0 ROW UNITS

9.1 DEPTH ADJUSTMENT

With the drill on a flat level surface check all coulter points are at the same depth before reaching the field.

The coulter depth can be infinitely adjusted in the following way.

- Firstly release the locking handle on the side of the row unit (A).
- Set the row unit depth by winding the handle (B) to the required depth.
- Once the required depth has been achieved, tighten the locking handle (A).
- Repeat for each row unit, depth can be matched by using the counter underneath the handle (B). To calibrate the coulters, wind the front wheel down as far as it will go, then loosen the grub screw on the side of the counter using an Allen Key (C). Rotate the boss on the counter to set it to 0000 then tighten the grub screw. Repeat this for all row units.

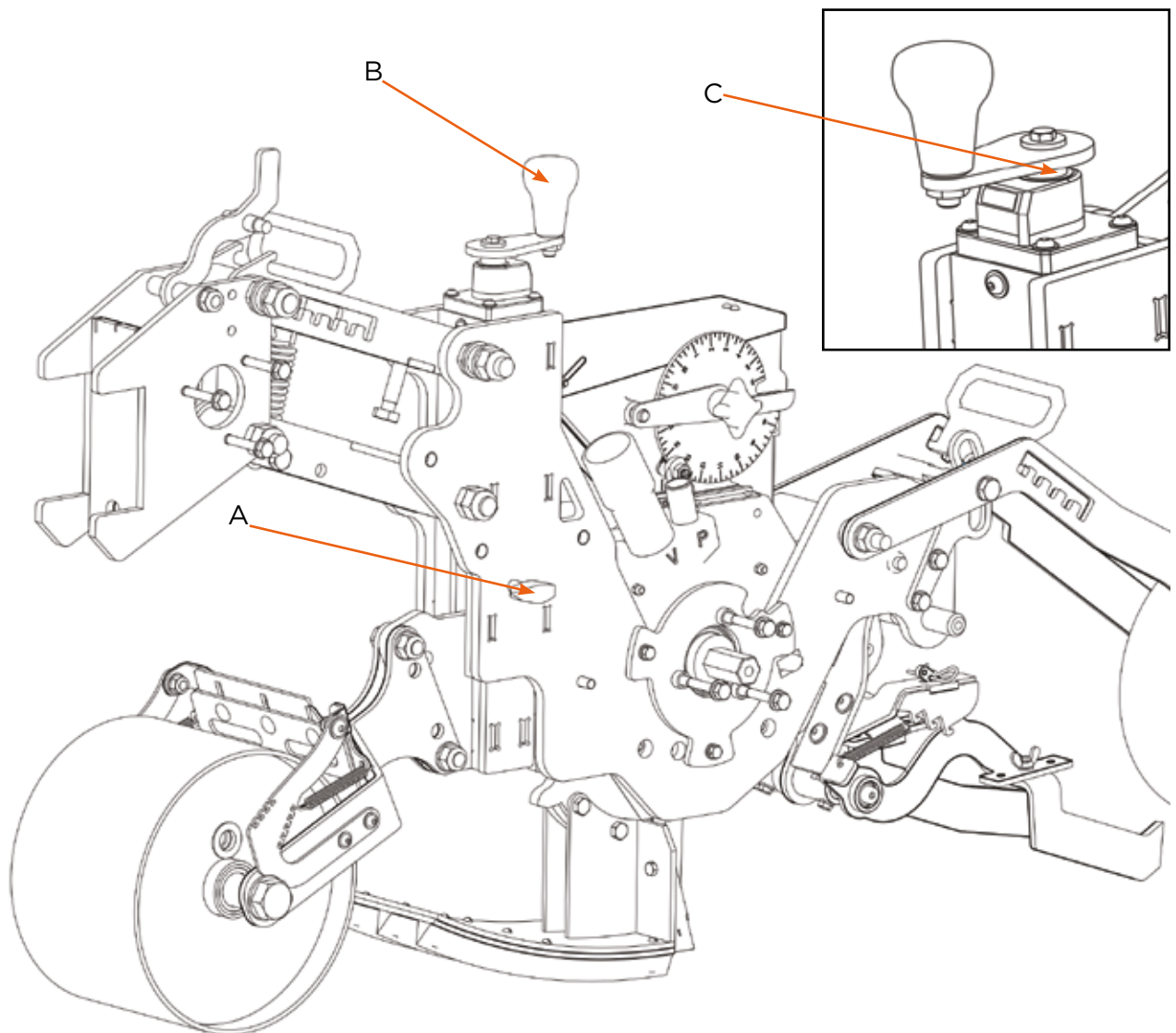

9.0 ROW UNITS

9.2 WEIGHT REDUCTION AND DOWNFORCE SETTING

The row unit is equipped with both downforce and weight reduction settings via the handle and spring assembly on the parallel links. Adjustment of both settings is easy and can be done by pulling the handle out of the keyway and sliding it up and down the parallel arm.

Below shows the positioning of the weight reduction and downforce settings depending on which hole the spring is located in on the lower link. As a rule of thumb if the spring is leaning towards the headstock it is acting as weight reduction and if the spring is leaning towards the depth control handle it is applying downforce eg settings 3, 4 and 5. If the spring is at 90 degrees to the lower link then the spring is effectively in 'neutral', the unit is operating under its own weight. eg. settings 1 and 2.

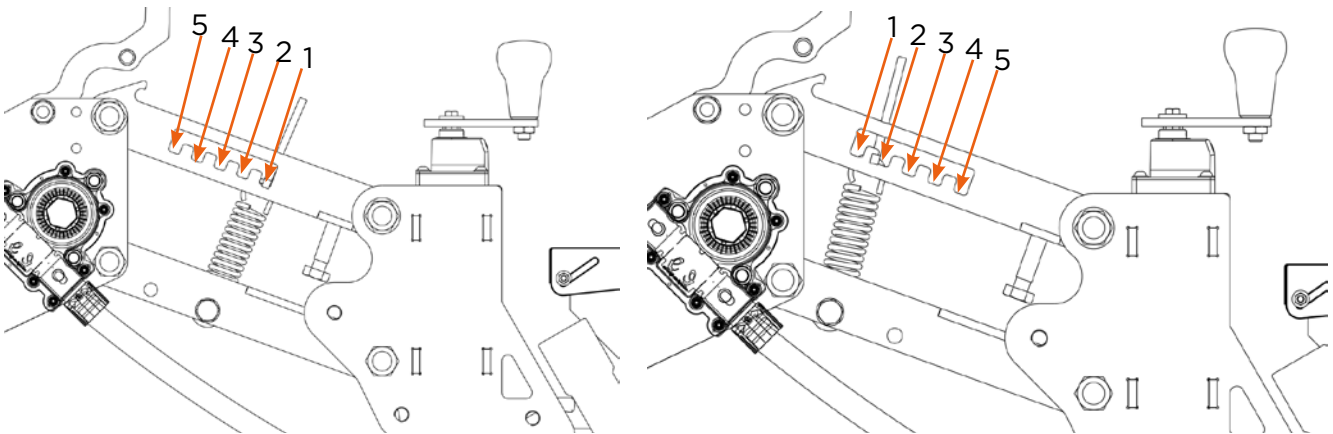

9.3 REAR WHEEL DOWNFORCE

Different amounts of downforce can be applied to the rear wheel of the row unit. To alter the rear wheel downforce, lift the handle (A) out of its locked position and slide up and down to adjust the downforce. Lock handle back in place to set the downforce, there are 5 settings for this. The further back the handle is the more downforce will be applied to the rear wheel.

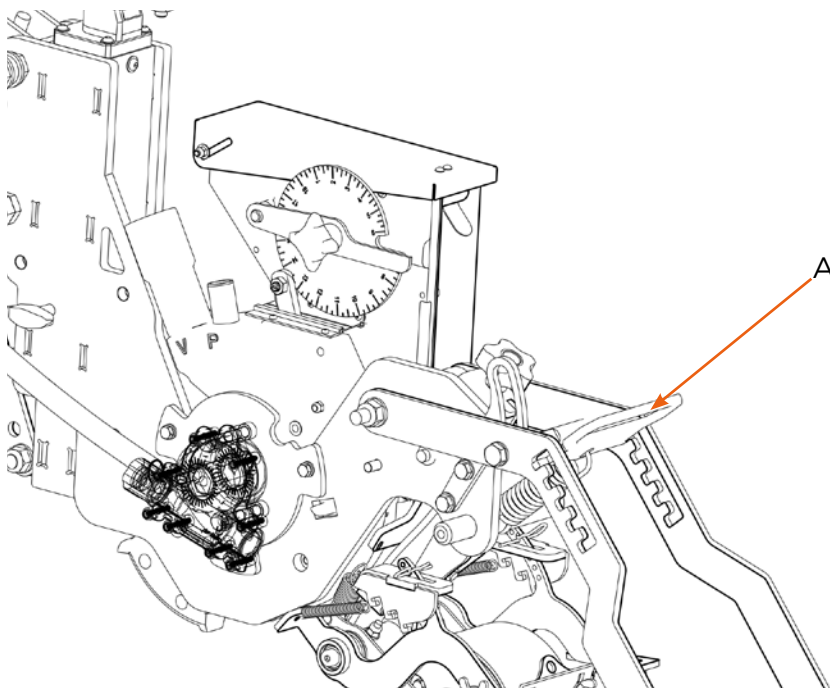

9.0 ROW UNITS

9.4 HYLINE/LOLINE SETUPS

Depending on what type of coulters are being used, depends on what setting the front wheel is fixed on. If the row unit has a hyline coulters fitted, the front wheel bracket will be cranked over. If the row unit has a loline coulters fitted, then the second hole will be used to fix the front wheel. This will drop the row unit down to match the shorter coulters.

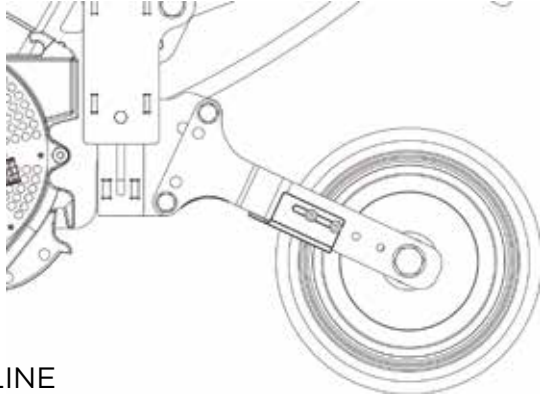

HYLINE

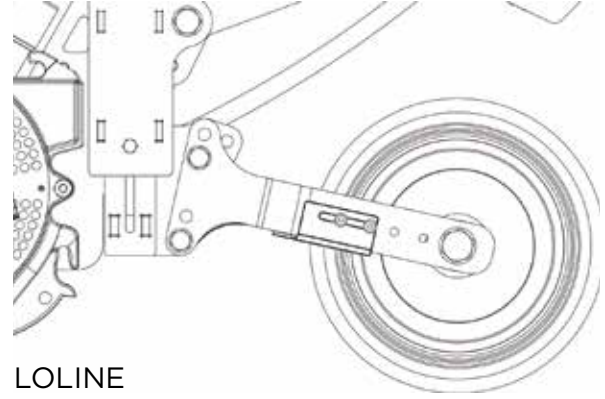

LOLINE

9.5 PRESS WHEEL ADJUSTMENT

If the individual articulated presswheel chassis are fitted then the downforce on these can be increased by turning the handwheel clockwise. To decrease downforce turn the handle anti-clockwise. The press wheels can also be latched out of work; this can be done by aligning the presswheel chassis and put an M10 locking bolt through them. The length of this bolt will vary depending on how many press wheels are fitted to the unit.

9.6 ROW WIDTHS

To alter the row unit widths firstly loosen all the grub screws on the bearings which support the hexagon drive shaft and remove the hexagon drive shaft. If the row width changes are minimal then the units can be slid along the toolbar; however it may be easier to remove each unit and refit to the correct width. Widths should be measured at the coulters tips before the clasp plates are re-tightened, the hexagon shaft can then be refitted and all bearing grub screws tightened.

9.7 PARALLEL LINK TRAVEL

The row units vertical travel can be adjusted via bolt (A). Bringing the bolt closer to the lower link decreases the amount of downwards travel while moving the bolt away from the lower link increase the downwards travel.

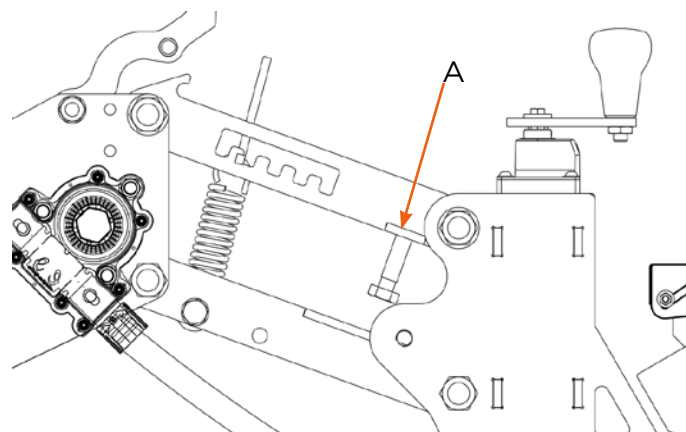

10.0 TOOLBAR

10.1 FOLDING FRAME

The folding frame allows a 6 metre drill to be transported by road without the need for a low loader trailer. This versatile frame features a 'bolt on' toolbar which allows a number of different drill set ups depending on what the customer wants. When configuring a folding drill contact a Stanhay representative who will let you know what is possible.

The toolbar forms the main chassis of the drill where everything is assembled on i.e the fan, row units, landwheels etc. The standard rigid toolbar used on all drills under 3.5m is 100x100 SHS; over 3.5m and up to 5m the 100x100mm wall thickness changes to 10mm over 5m width and the dimension for a rigid toolbar changes to 180x180 SHS or a folding frame is used.

10.2 RIGID

No maintenance is required on the rigid toolbar however if extra row units or landwheels have been fitted to a factory spec drill then care needs to be taken not to overload the toolbar.

11.0 PREPARATION IN THE YARD

11.1 CLEAN METERING UNITS

- Empty seed from hopper, using removable drain plug, or vacuum seed emptying device.
- Remove hopper side of metering units and ensure the unit is absolutely clean.
- Use soft brush to clean vacuum galleries (A) dry cloth to clean face of gallery block; airline to blow dust and seed dressing from inaccessible areas of the galleries.



Body side of the metering unit need not be removed from the row unit chassis for cleaning preparation or setting.



Remove pressure hose from metering unit to allow dust to escape, and direct airline behind turntable (B) and through hole cleaning jets (C).

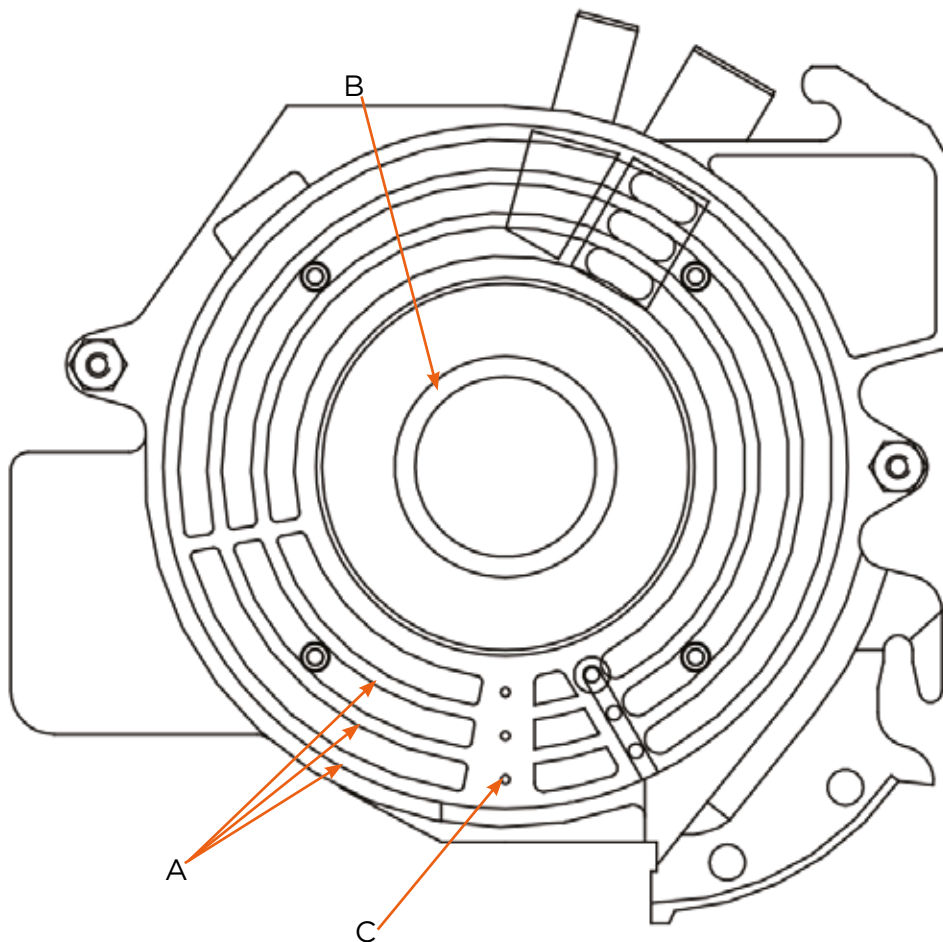

Avoid using dirty or heavily dressed seed, as the unit will not function correctly with such seed, if it's use is unavoidable the unit must be cleaned more frequently.



Metering units should be cleaned at least twice a day and after work.

11.0 PREPARATION IN THE YARD

11.2 CHANGING THE GEAR RATIOS IN THE GEARBOX

To set the correct ratios for seed spacing follow the instructions below:

- Loosen the clamp handle (A) on the side of the landwheel to release the idler sprockets.
- Undo the grub screw in the required sliding sprocket (B) - it may be necessary to rotate the landwheel so that the grub screw is accessible.
- Fit the chain over the required sprocket in the cluster (C).
- Then fit chain over the sliding sprocket then re-tighten the idle sprockets (D) the with clamp handle.
- Rotate landwheel and check the chain is running in line.

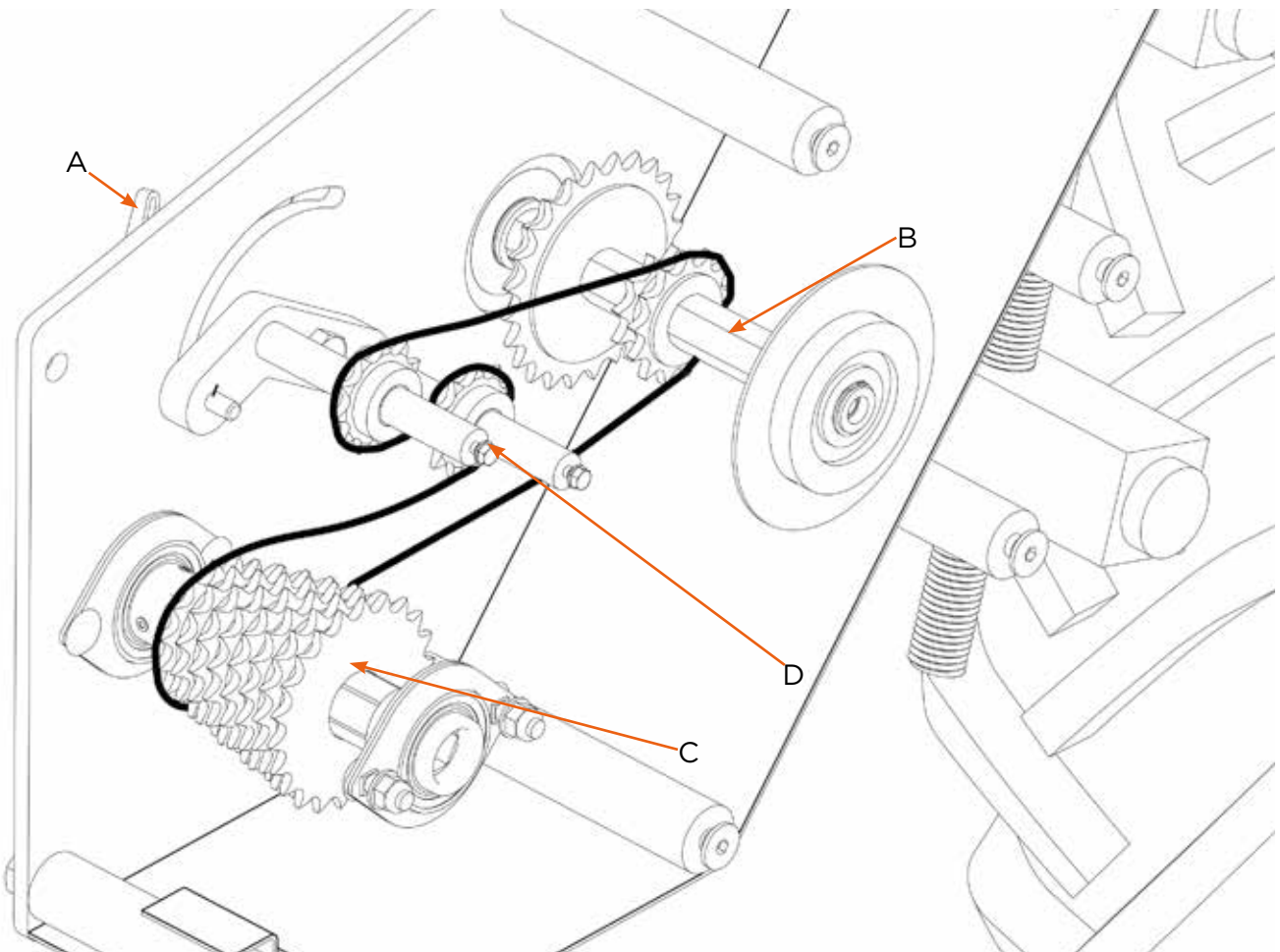

Ensure the drive chains are correctly tensioned and the clamp handle is locked before use. Improper use can lead to serious damage to the gearbox.



Gearboxes connected to the same hex shaft must be set the same or major mechanical damage could result.

11.0 PREPARATION IN THE YARD

11.3 PRIMARY DRIVE SPROCKET FITMENT

For some spacing requirements it may be necessary to change the primary drive sprocket; two types of sprocket are supplied with the drill - 24T and 40T. To change between sprockets follow the instructions below:

- Remove the chain guard on the side of the landwheel, this will reveal the chain and sprockets.
- Determine the type of sprocket that is to be fitted - 24T uses a 125P chain, 40T uses a 137P chain.
- Remove the chain, primary drive sprocket and the two jockeys.
- Fit required primary sprocket.
- Fit jockeys in either position 1 (24T) or 2 (40T) as seen in the images below.
- Fit correct chain depending on sprocket and tension using the jockeys.



Do not over tension the chain.

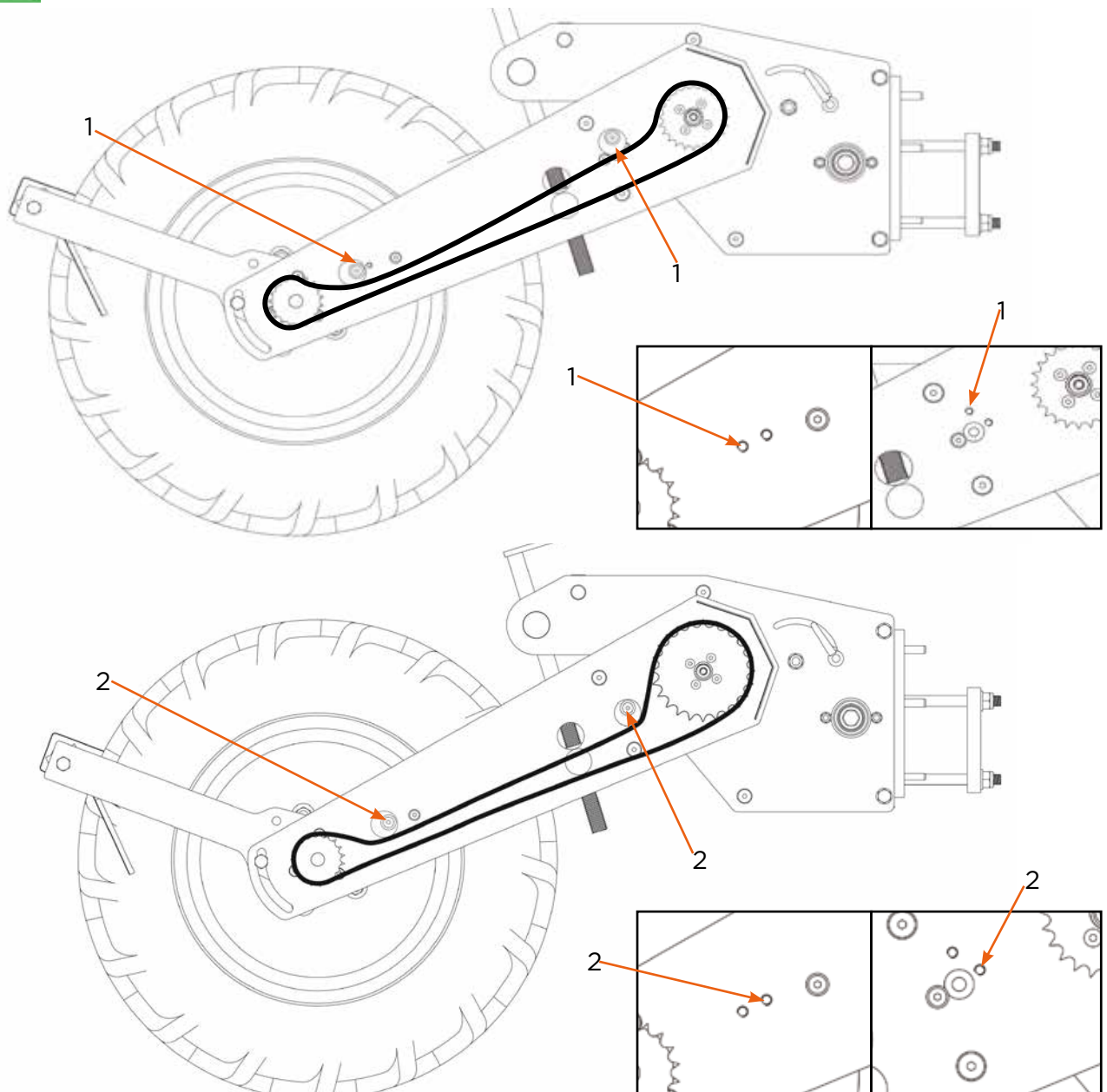

11.0 PREPARATION IN THE YARD

11.4 FAN START UP AND FITTING SEED DISCS



Before start up the belt tension should be checked. This is factory set on new machines but should be checked annually or after periods of long use. If a screeching noise is heard stop immediately and check fan belt tension – refer to fan belt tension instructions.



Only engage PTO or hydraulic motor at low speed initially and never exceed maximum rotation speed.

- With valves fully open start tractor and engage PTO / hydraulic motor and increase fan speed until the vacuum gauge reads 30mb.
- With hopper sides removed fit seed discs ensuring they seal correctly against the gallery blocks.



Seed discs should be fitted with the part number facing outwards. On mild steel discs the concave side should face towards the gallery block. Seed discs should seat firmly against the gallery block without vibration or noise, a disc that does not seal correctly can be turned over and re-checked, if functional it can be used this way around. A disc may need to be turned over after some work but this will occur only once in it's life time.

- Having established which way round the discs should be fitted, mark the outside face of the disc with a felt tip pen-to avoid future incorrect fitting.
- Mark the seed discs so they remain with their respective units, and always fit them with the etched part number opposite the 'orange' dowel on the unit turntable.
- Steadily increase fan speed until required vacuum is reached. On PTO driven fans this can be done by adjusting engine speed. On hydraulic models this should be done by altering the hydraulic flow.
- Rotate landwheel drive in forward direction and check all seed discs remain firmly seated without vibration or noise.



A seed disc that does not appear to work should be tried on a unit that is working to establish that the problem is with the seed disc and not the offending unit.



Do not increase vacuum to force disc to seal as this could lead to faster wear and poor seed placement.



On hydraulic fan models do not exceed 30lpm. Increased flow rate above 30lpm will not increase the fan speed but will lead to excessive heat build up in the hydraulic block and may cause damage.



Always stop fan or remove vacuum hose before removing seed discs or damage may occur.

11.0 PREPARATION IN THE YARD

11.5 SET VACUUM/ PRESSURE

- Increasing fan speed increases both vacuum and pressure
- Closing valve (A) increases pressure and reduces vacuum
- Valve (B) is normally left fully open, closing it reduces both vacuum and pressure
- To set the correct pressure progressively close valve (A) until gauge reads 20% of vacuum or 10mb whichever is higher. Tighten the handwheel to lock in position. If pressure reading is too high even with valve A fully open, remove plugs from unused pressure ports.

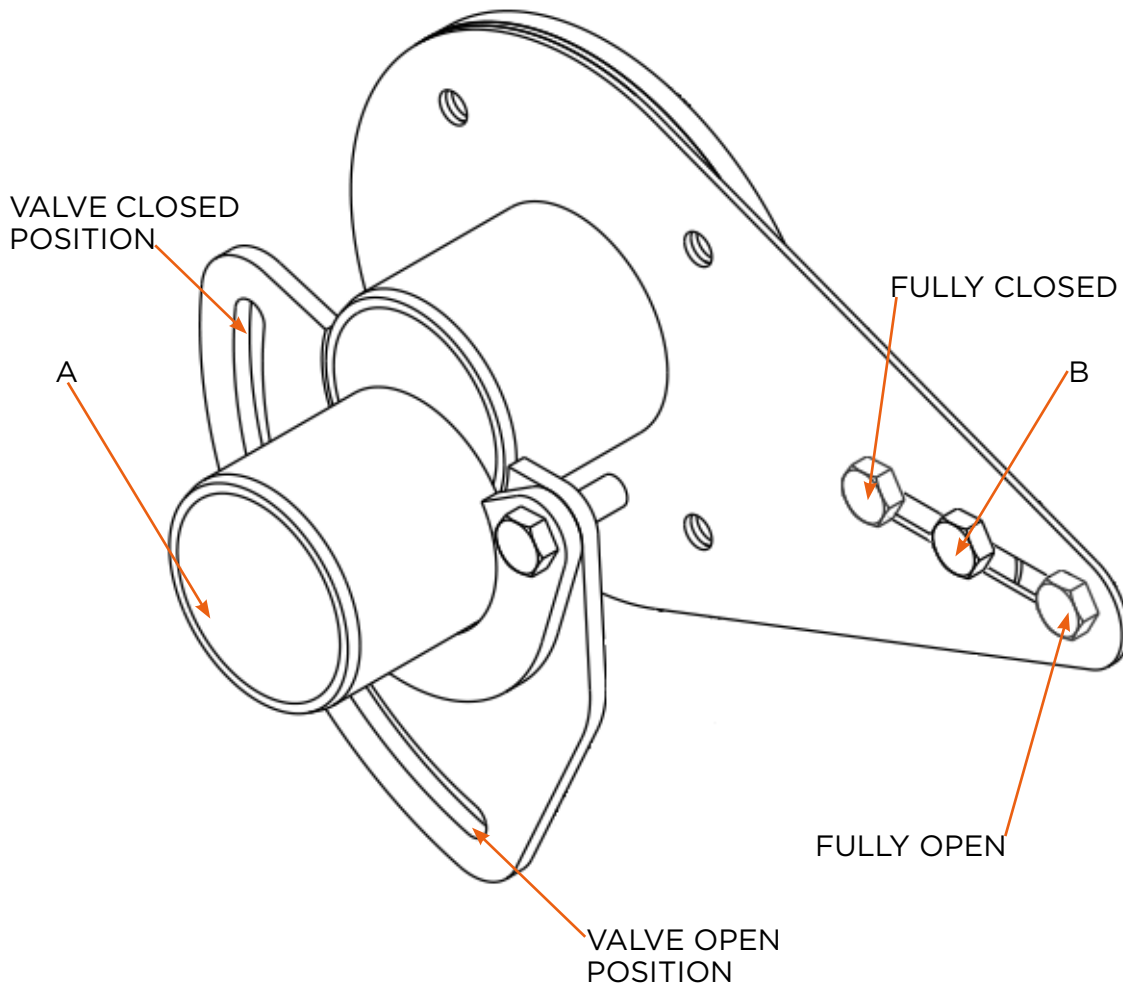

In the field the vacuum and pressure settings may need readjusting once the discs are primed with seed.



Operators do not need to run the tractor at 540/1000 equivalent, the fan only needs to produce enough vacuum/pressure for the type of seed being used.



Never exceed maximum fan speed.

11.0 PREPARATION IN THE YARD

11.6 REASSEMBLE METERING UNITS

- Refit hopper side of metering units taking care they are not held apart by the top sealing brushes, seed guides or agitator gears, if necessary rotate agitator spindle slightly to ensure gears mesh.
- Lightly tighten both conical nuts and then again rotate the landwheel drive to check all units rotate freely.

11.7 UNIT SETTING AND CALIBRATION

- Raise machine fully until main drive wheels are clear of ground.
- Pull singulator arms away from singulator cams and then release: repeat several times to ensure singulators are settled in the correct working position flat on the seed discs. Rotate cams to setting 16 for zero singulation. Check seed emptying plugs are securely fitted and put seed in hoppers. Place a container for collecting seed under each unit.
- Rotate landwheel drive in forward direction at approx required RPM, check the seed discs are picking up seed with very few misses.
- Choose a convenient unit to calibrate, where the seed disc is easily visible. Rotate the landwheel at the same approx required RPM and adjust singulator cam on the unit until there are no seeds on the disc, then gradually adjust to bring seeds back onto the disc until there are mainly single seeds. Clamp singulator cam with handwheel and re-check.
- When satisfied, set singulators on all remaining units to the same setting as the calibration unit. Clamp singulators cams and empty seed containers into hoppers.
- For a more accurate check of this setting, the seed metered from each unit performing the same number of revolutions can be weighed to check all units are metering an equal amount of seed.



Better distribution is obtained at lower vacuum levels, so do not be tempted to increase vacuum excessively to eliminate the odd miss which is unavoidable with some seed.



Whilst all singulators are factory calibrated, on small seeds variation between units could be up to 5%. To improve this individual small adjustments may be required on each unit to achieve perfect singulation.



Where singulators have been replaced they may require re-calibrating (see calibration instructions).



Singulators will wear and the performance of the unit should be checked periodically, it is the operators responsibility to check seeding performance is satisfactory at all times.

12.0 PREPARATION IN THE FIELD

12.1 SET TOOLBAR HEIGHT

Set the toolbar height by adjusting the landwheels turning handle (A) Set the height to 510mm (550mm for 180mm Toolbar), measured between the surface of the seedbed and the centre of the toolbar. The drill headstock and toolbar should be perpendicular to the ground, this can be altered by adjusting the length of the tractors top link. When set correctly this ensures the maximum allowable travel can be achieved by the row unit to correctly follow the ground contours.

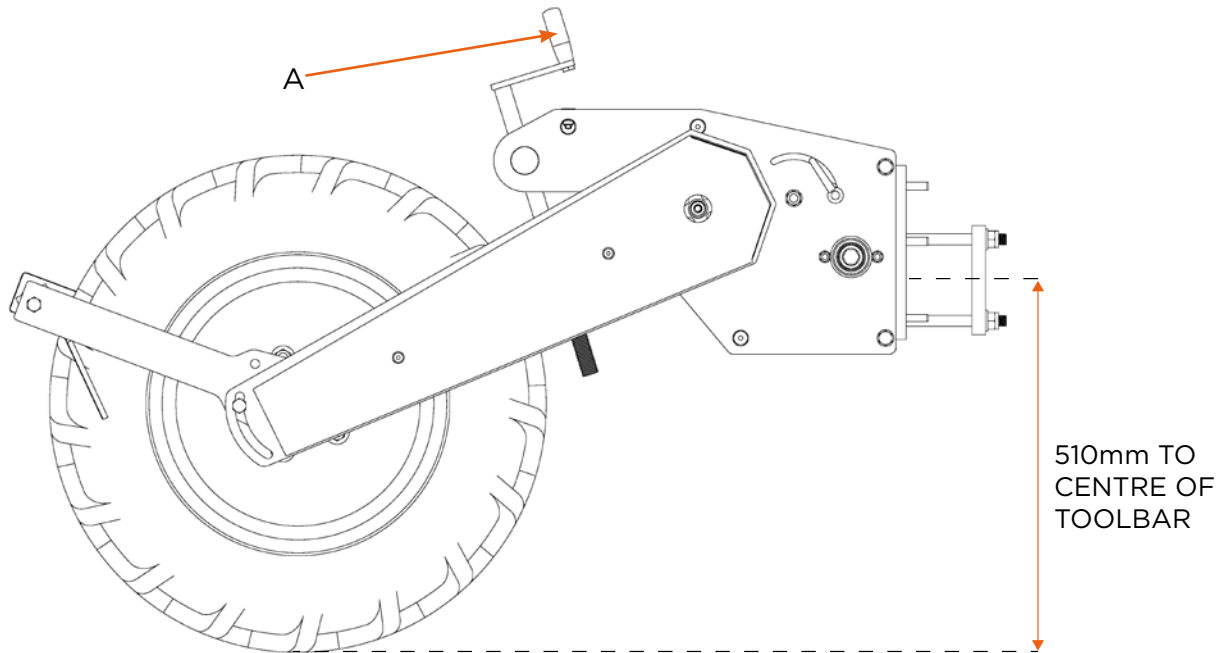

12.2 CHECK SEED DELIVERY

Fill hoppers evenly with seed and close lids firmly. Rotate landwheel drive by hand and check all discs are picking up and delivering seed evenly. Check coulters for any blockages and if there is dampness on the coulters ensure they are dry to prevent seed blockages using a cloth or airline.



Seed should be good quality, clean, with no soil, stones, paper, etc. Avoid using heavily dressed seed as the dressing will be sucked off the seed and deposited in the vacuum galleries.

12.3 DRILLING DEPTH

Field adjustment of sowing depth is most easily achieved by progressively adjusting coulters downwards until the desired sowing depth is achieved. The procedure for this varies between models.

12.0 PREPARATION IN THE FIELD

12.4 SEED PRESS WHEELS

- Adjust spring force of press wheel as required (if fitted).
- Adjust scrapers as required.



Take press wheels out of work in damp conditions, if in doubt remove from work.

12.5 SEED COVERERS

Where arm coverer's are fitted set maximum working depth and draft angle as required. For single line work only 1 arm is required. They should be set to move the minimum amount of soil required to cover the seed – moving too much soil can effect seed distribution.

Where drag coverer's are fitted set the chain link lengths to pull the coverer evenly over the soil.



It is recommended that a drag coverer is used for multi-line drilling over 100mm.

12.6 CLOD DEFLECTORS (IF FITTED)

Set at minimum depth and progressively increase depth as required.

13.0 FIELD OPERATION

13.1 TRACTOR LINKAGE CONTROL & COULTERS

- Lower and raise machine on the move to prevent coultter blockages.
- Raise machine and check coultters for blockages if you have stopped for any reason whilst drilling.
- Move tractor linkage control lever to "fully down or float" position when going into work to ensure adequate land wheel drive.

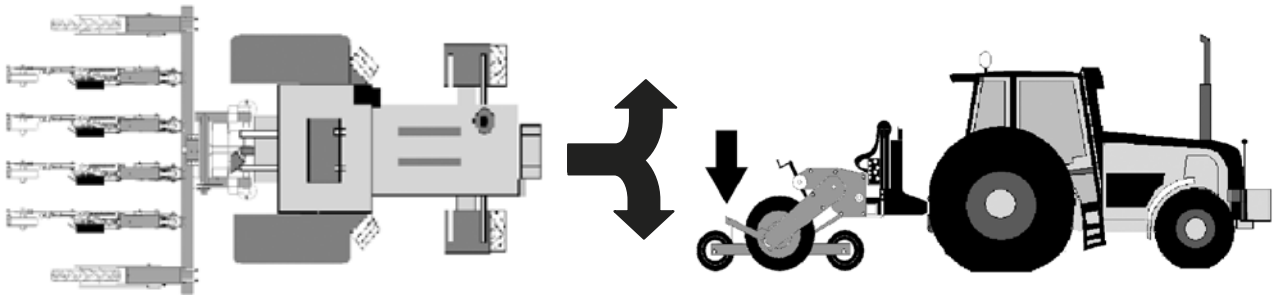

Do not attempt to turn to the left or right with the implement in the ground. Always raise the implement before turning.

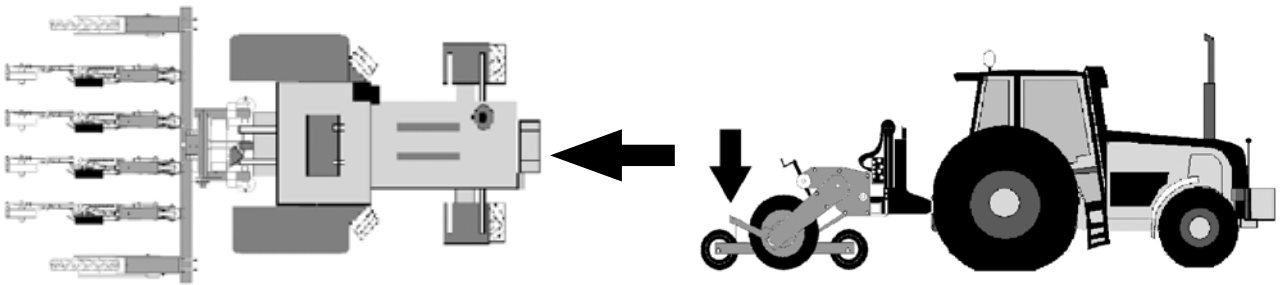

Do not attempt to reverse with the implement in the ground. Always raise the implement before reversing.

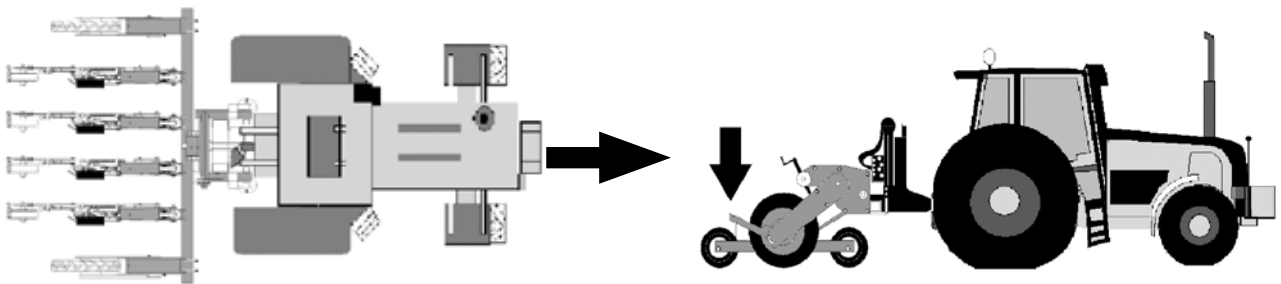

Do not drive at excessive speeds when drilling.

13.2 HOPPERS & TRANSPORT

- Keep hopper lids firmly closed except when filling.
- Always empty hoppers of seed before transporting machine or driving long distances.
- When travelling short distances keep fan on to ensure discs remain seated against vacuum galleries.

13.0 FIELD OPERATION

13.3 GAUGES & SEED DISCS

- Check vacuum and pressure reading during work; immediately investigate cause of any unexpected change of readings, or of any unusual noise from the fan. A loud 'whistling' noise from the metering unit indicates complete loss of vacuum.
- Regularly check unit performance. To check seed disc pick up raise machine on the move at normal drilling speed, maintain vacuum, stop and inspect seed discs.



Misses usually indicate blocked holes in disc, or unit requires cleaning.

- Wipe seed off the disc in the area of the singulator before replacing hopper side of metering unit, to avoid trapping seed between the singulator and the disc.
- Clean units at least twice a day and after work. Do not leave seed, seed dressing or dust in the unit overnight.
- If the machine is to be out of use for more than one day, the seed discs should be removed and stored in a dry place. For care of seed discs see seed disc section.

13.4 SEEDING PERFORMANCE

To confirm accurate seed placement the following checks should be done periodically.

Seed metering should be checked before work and when refilling via either of the two following procedures:

- Volume method – Put the same volume of seed in each hopper. If the seed levels are significantly different from the calibration unit, adjust the singulator.
- Weight method – Put the same weight of seed in each hopper. Periodically empty and weigh the seed remaining in each hopper. If the weight of the seed remaining in any hopper is significantly different from the calibration unit adjust the singulator.

Seed spacing and depth should be checked in the field by uncovering rows after the drill to ensure the results are as required. Many settings can be adjusted to obtain the optimum performance and these checks are critical, particularly in the first few hectares of work to confirm the correct settings.

13.5 WHEELS

Check all wheel scrapers are set correctly and keeping wheels clean at all times.



Correct operation is the responsibility of the operator who should check periodically that the desired seeding rate, planting depth and machine performance are being achieved.



Do not operate in very sticky conditions: for efficient performance soil engaging components such as wheels and coulters must remain clean.

14.0 AFTERCARE

14.1 EMPTING THE SEED HOPPERS

At the end of operating the drill or when the seed type needs to be changed, the seed hoppers need to be completely emptied. There are two options that can be used to empty the seed hoppers:

- Turn the sprung steel latch (A) and remove the black plastic bung (B) at the bottom of the hopper ensuring you have a suitable container directly underneath this point to collect any seed.
- Use the seed vacuum emptier to suck the seed out through the hopper filling opening.

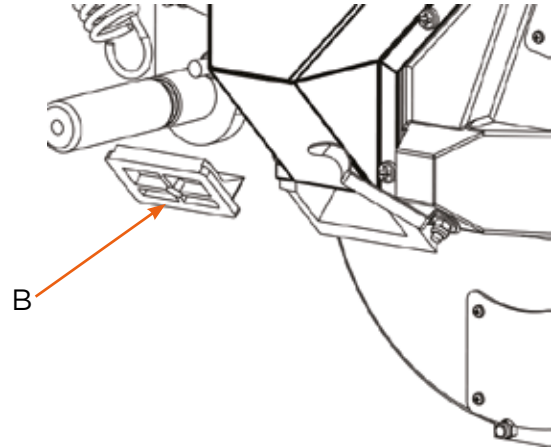
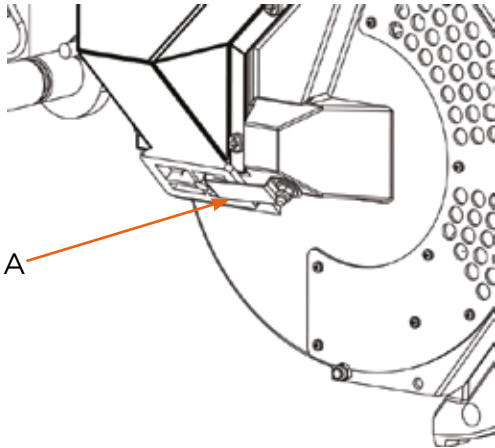

WARNING!

Danger due to possible contact with pesticides!

Always adhere to the information given by the seed suppliers. Observe the manufacturers safety data sheet.

14.2 CLEANING

In order to keep machine wear down to a minimum, follow the instructions given below:

- Remove dirt, deposits and inflammable material from the entire machine on a daily basis.
- Inspect the machine for damage once a week and replace defective parts immediately.
- Do not wash the machine with high or low pressure water sources. The machine should be kept dry and is best cleaned with pressurised air.
- Remove seed discs and store them in the storage bags issued with the discs.
- Clean the gallery blocks behind the seed discs with a soft dry brush.



WARNING!

Risk of Injury!

Deposits are either flammable or may cause a fire. Also walking on surfaces that are soiled have a risk of tripping or slipping.

- Clean dirt, deposits and combustible material daily off the machine to ensure machine is kept in good working order, reduce the risk of accidents and avoid damage.



WARNING!

Risk of Injury! Serious and fatal injuries possible!

Parked machines can roll away if not properly shut down.

- Only carry out cleaning work when the engine is switched off, parking brake is applied and ignition key has been removed.

14.0 AFTERCARE

14.3 STORAGE

The following information should be taken into account when storing the machine at the end of the season:

- Clean the machine thoroughly. Dirt will attract humidity and causes rust.
- Park the machine in a dry place. Do not store the machine near where any artificial fertiliser is kept (mineral fertiliser).
- Thoroughly clean and grease all drive chains with a dry grease (for example NLGI class 2 grease with EP additives).
- Lubricate non-painted machine parts, threaded spindles and piston rods of the hydraulic cylinders with biologically decomposable oil/grease.
- Leak test of all hydraulic components. Eliminate leakages immediately.
- Check the ease of moving parts/ joints, remove them if necessary, clean them and check for wear. Replace with new parts if necessary.
- Lubricate the machine thoroughly.
- Repair paint damage, conserve ground machine parts once more with rust-proofing agent.
- Operator terminals must be stored such that they are protected against humidity, front, sun, soiling.
- Remove seed discs and place them inside a sealed bag.

**WARNING!**

Parked machines may roll away on an inclined surface and cause serious and fatal injury!

- Secure the machine against rolling away.

15.0 DISMOUNTING THE MACHINE

The following steps must be carried out in sequence to dismantle the machine:

- Empty the seed hopper.
- Discharge the ballasting of the machine if fitted.
- Deploy the parking stands and lower the machine down so it sits on the parking stands.

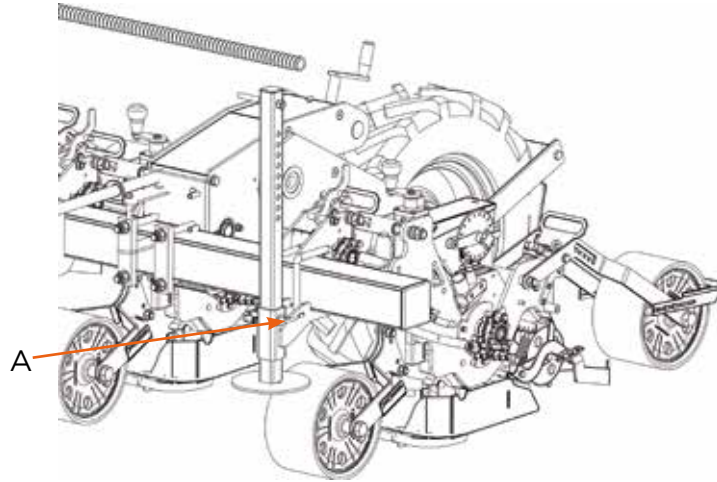

The procedure for lowering the parking stands is detailed below:

- Lift the machine up off the ground via the 3 point linkage on the tractor.
- Switch off tractor, apply the parking brake and remove ignition key.
- Remove spring clip and remove pin (A).

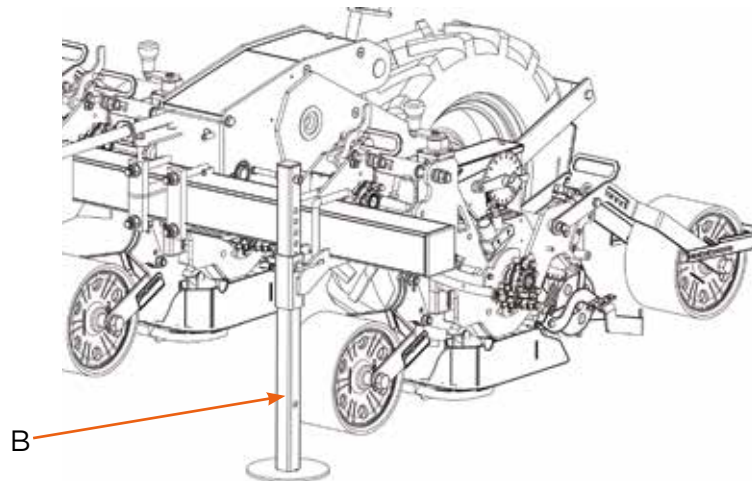

- Slide parking stand foot (B) down so that it locates with one of the mounting holes in the parking stand.
- Fix the pin and spring clip back into the parking stand.
- Drop the machine down using the tractors 3 point linkage. Ensure when the machine is in its parked position that the metering unit coulters are not touching the ground. If this occurs, lift the machine back up on the 3 point linkage and drop the parking stand down into another hole to fix the drill in a higher position.
- Switch off tractor, apply parking brake and remove ignition keys.
- Disconnect the hydraulic hoses from the tractor. Fix the hoses onto their fixing point on the machine to ensure they stay clean.
- Finally disconnect the machine from the tractors 3 point linkage.

15.0 DISMOUNTING THE MACHINE

**DANGER!**

The hydraulic system is under high pressure!

Hydraulic fluid escaping under high pressure can penetrate the skin and cause serious injuries. If this occurs, seek immediate medical assistance.

- Take appropriate action when uncoupling hydraulic hoses.
- Depressurise the hydraulic system before disconnecting the hydraulic hoses.

**WARNING!**

Risk of burns!

If the hydraulic system has been operated for a long period of time, there is a risk of it being at a high temperature. This could cause serious skin burns.

- Take appropriate action when uncoupling hydraulic hoses.
- Let the hydraulic system cool down before working on it. Ensure correct protective equipment is worn.

**CAUTION!**

Risk of crushing! Injuries possible!

Risk of injury on manually movable machine parts.

- When operating manually movable machine components, ensure care is taken around pinch and shear points.

**WARNING!**

Risk of crushing!

Serious injuries and death possible! People standing between the tractor and the machine while its being attached are at risk of injury.

- Ensure tractor operator is competent. Check tractor operator manual if required.
- Only enter the area between the tractor and the machine when the tractor is switched off, the parking brake is applied and the keys have been taken out of the ignition.

**WARNING!**

Danger of falling or tipping if the ground is unstable!

Machines on uneven or soft ground could tip/fall over.

- Ensure the ground on which the machine is parked must be dry, firm and level.

16.0 GENERAL MAINTENANCE

16.1 MAINTENANCE STAGES FOR THE MACHINE

In order to maintain operational reliability, the machine must be checked, serviced and maintained at regular intervals. This must be done at different maintenance levels for which different groups of persons are responsible. A difference is here made between maintenance work carried out by the machine operator, the Stanhay dealer and the Stanhay service technician.

If the prescribed maintenance jobs are not carried out by the respectively responsible person, the warranty shall lapse.

The machine operator must ensure that all stipulated measures are carried out in due time and are also recorded. This includes daily cleaning just like presenting the machine for an inspection at the Stanhay dealer.

Certain maintenance jobs may only be carried out by specialist staff (Stanhay service technician or Stanhay dealer). The maintenance levels determine unambiguously who has to carry out the stipulated measures.

The division into maintenance stages stipulates that:

- The machine operator carries out the binding measures described in the maintenance table (e.g. cleaning, lubricating, checking).
- The machine operator initiates the execution of the measures. Apart from that, he must monitor the maintenance intervals and is responsible for presenting the machine at the Stanhay dealer in due time.
- The Stanhay dealer carries out the measures the machine operator may not carry out or cannot carry out due to not having access to specialist equipment (e.g. lacking crane).
- The Stanhay dealer, in consultation with Stanhay Service, carries out certain measures and decides on the basis of the maintenance tables whether an order for a Stanhay service engineer has to be placed.

16.0 GENERAL MAINTENANCE

16.2 MAINTENANCE TABLE FOR THE MACHINE OPERATOR

CHECK	CHECK	ACTION
On Delivery	Metering Units	Mark identification number on both halves of each metering unit and on each singulator.
	PTO Shaft	Start PTO raise machine fully. Adjust stop on tractor linkage control lever. If necessary, shorten PTO shaft to ensure end float at all times. Fit the PTO drive shaft cut to length as required. 'Try to obtain maximum sliding profile overlap, but without bottoming out, to avoid mechanical damage to the fan unit' FOR FURTHER INFORMATION SEE THE SHAFT MANUFACTURERS SERVICE INSTRUCTIONS
Daily	Discs	Check that the holes in the seed discs are clear of debris. Check that the disc seals against the gallery block correctly when the fan is on and there is no audible vibration when the disc rotates.
	Clean Metering Units	Ensure that the inside of the metering units are cleaned and free of any seed residue at the end of each day.
	PTO Shaft	Check PTO shaft is greased and there are no knocking noises once PTO is running. Check chains.
Weekly	Hoses	Check hoses are correctly and securely fitted: Raise and lower machine and check for kinks and do not contact shafts, sprockets or chains.
	Grease points/ Oil chains	Grease all points on the drill and lubricate drive chains.
	Check Hydraulics	Check hydraulic systems are in good working order and not leaking (if fitted).
	Nuts and Bolts	Check fittings and fixtures are sufficiently tightened whilst still allowing pivot points to move freely.
	Coulters	Check that ribs or bases on the coulters are not excessively worn or damaged as this will severely impede the consistency of the drilling depth.
	Tyre Pressures	Chain drive landwheels: 6.00 – 16 3.3 bar (48psi)
	Check Drives	Check sprockets and chain drives run freely and teeth or links aren't worn or damaged.

16.0 GENERAL MAINTENANCE

16.3 INSPECTION/MAINTENANCE

The following maintenance instructions are designed to help you to ensure that the machine is always ready for use, provides the necessary operating and traffic safety, thus preserving the high value of the Stanhay products through careful maintenance, servicing and technical monitoring.

- Regular cleaning is a part of maintenance. Dirt attracts humidity and causes rust. All coarse external dirt must be removed. Rectify paint damages at the earliest opportunity. Always keep sensitive and important elements such as magnets, valves, warning boards and displays clean.
- Regularly check all hydraulic components for leakages. Repair leakages immediately. Loss of oil can lead to malfunctioning or loss of operating and traffic safety. In addition leaking oil contaminates the environment.
- Check moving parts (pivot points etc.) regularly for ease of movement, dismantle if necessary, clean and check for signs of wear. Replace with new parts if necessary. Defective or non-functioning parts can hamper the operational reliability of the machine. Also check the fastening elements (such as screws and nuts) regularly and tighten them, if necessary.
- Do not operate machines or appliances with defective parts or parts that are not functioning properly, irrespective of whether these are electrical, hydraulic or mechanical parts. This can result in serious failures or accidents. The manufacturer does not accept any liability in such cases.
- Stanhay recommends that you carry out functional tests at regular intervals and maintain a log of the same. You can thus detect unplanned wear and tear at an early stage and quickly rectify the cause.
- Early detection can help you identify malfunctioning of the machine, prevent damage and thus any other hazards that may arise from such damage. Therefore, always pay attention to any unusual noises or loose fastening elements.
- Consistent checking and proper maintenance can also help you in reducing repair costs and down times. Reliability and service life are increased at the same time.
- Machine check with the Stanhay dealer: The trained expert staff at your local Stanhay dealer will competently carry out maintenance and repair work on Stanhay precision seed drills. We recommend all the users of our products to work out an action plan for machine maintenance together with their dealer.



Damages of any type, production losses or accidents caused by poor maintenance and care cannot be attributed to the manufacturer and are thus excluded from any liability of the manufacturer!

16.0 GENERAL MAINTENANCE

16.4 SPARE PARTS

Please quote the type designation and the identification number of the machine when ordering accessories and spare parts.

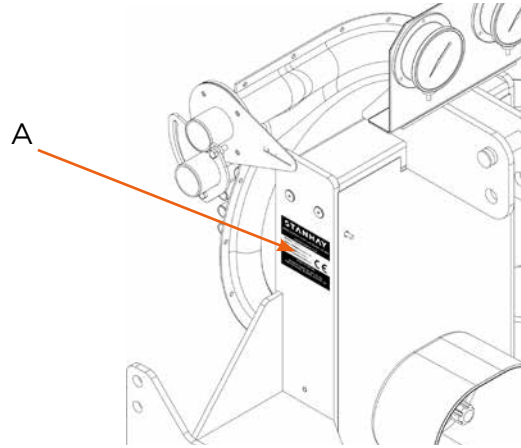

The identification and type plate is positioned on the side of the headstock (A).



The use of spare parts supplied by other manufacturers is prohibited. Original spare parts and accessories approved by the manufacturer are a contribution to safety and guarantee proper functionality. No liability can be taken for consequences resulting from the use of other parts.



The identification plate is a critical part of the drill and must not be removed, changed or made illegible!



When replacing electrical or hydraulic parts, only use original Stanhay spare parts. The use of parts purchased elsewhere can cause malfunctioning of the machine.

16.5 WELDING WORK

Incorrect welding work compromises the machine's operating reliability and safety.

The following information must be observed prior to any welding work:

- The machine must be uncoupled from the towing vehicle prior to any welding work.
- Welding work should only be carried out by an experienced/qualified personnel or consult a Stanhay dealer.
- Always fasten the earth terminal of the welding machine to the part to be welded or to a point in the immediate vicinity of the welding point.



DANGER!

Risk of injury! Serious injuries and death possible!

Incorrectly carried out welding work compromises the machine's operating reliability and safety. Serious accidents and machine damage may result.

- Have welding work only carried out by experienced qualified personnel.

16.0 GENERAL MAINTENANCE

16.6 TIGHTENING TORQUES FOR SCREW CONNECTIONS IN GENERAL

Check all screws and nuts regularly for tight fit. When replacing screws and nuts, make sure that corresponding fastening elements are of the same or a higher quality grade. Make sure that threads are clean and screws are correctly inserted. This prevents damage during tightening.

The necessary tightening torques can be found in the table. The screw's strength class is specified on the screw head.



The tightening torques given in the table below do not apply when a different torque is specified for certain screws and nuts.

TIGHTENING TORQUES				
		Strength Class		
		8.8*	10.9*	12.9*
Thread Size (mm)	Spanner Size (mm)	Tightening Torque (Nm)		
M6	10	9.5	14	16.5
M8	13	23	34	40
M10	17	46	68	79
M12	19	79	117	135
M14	22	125	185	215
M16	24	195	280	330
M18	27	280	390	460
M20	30	390	560	650
M22	32	530	750	880
M24	36	670	960	1120
M27	41	1000	1400	1650
M30	46	1350	1900	2250

* The strength class of the nut must also be taken into account when a through-type screw connection is concerned. The tightening torque of the lesser strength class is to be used when nut and screw are of different strength classes.

- 8.8 for the screw corresponds to strength class 8 of the nut
- 10.9 for the screw corresponds to strength class 10 of the nut
- 12.9 for the screw corresponds to strength class 12 of the nut

16.0 GENERAL MAINTENANCE

16.7 LUBRICATION POINTS

- Remove dirt from lubricating nipples prior to applying grease.
- Do not apply too much grease to the bearings/ guides.
- Remove excess grease escaping from bearings.

16.7.1 LUBRICANT RECOMMENDATION

To ensure the perfect operation at all times, it is recommended to use NLGI class 2 greases with EP additives; compatible with plastic materials, NBR elastomers, copper and copper alloys.

**DANGER!**

Rotating or moving machine parts can pull in or sever limbs. Unsecured machines on wheels can roll over persons - danger of injury!

- Switch off the engine prior to any work which requires staying in the danger zone.
- Secure the machine against rolling away!

**DANGER!**

There is a risk of injury at dangerous machine parts without protective cover!

- All protective devices or covers that were removed must be properly reinstalled once the adjustment or repair work has been completed.

16.7.2 CHAINS

It is recommended that all drive chains on either the landwheel or row unit have a dry lubricant applied after every week or as required. Do not use grease or other wet lubricant as this may attract dust and grit into the workings of the machine.

17.0 METERING UNIT MAINTENANCE

17.1 AGITATOR REPLACEMENT

To replace the agitator hold the agitator spindle with a pair of grips, remove the bolts at points (A) and (B) (Left hand threads), the spindle can now be removed and a new one fitted.

17.2 AGITATOR FINGER REPLACEMENT

When replacing the agitator fingers pull out the damaged or worn ones with a pair of pliers. To fit a new finger thread it through the hole in the agitator spindle then pull the remainder with a pair of pliers until it locates.

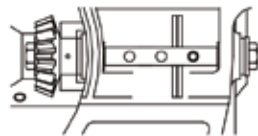
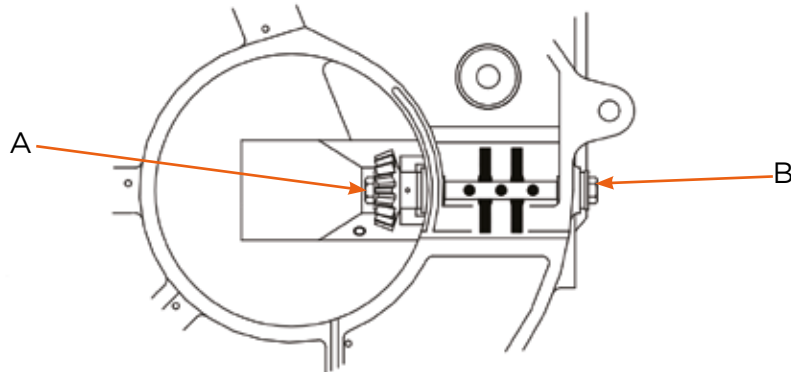

PARSNIP AGITATOR

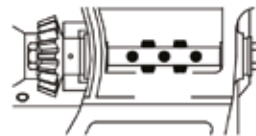

PELLET AGITATOR

17.3 FELT REPLACEMENT

- Remove the old felt with a screwdriver or knife and ensure channel in casting is clear of debris.
- Fit new by flattening along the length, normally by clamping in a vice, place the felts into the channels and tap into place with a rubber hammer.
- Trim excess felt with a scalpel so that they are flush with the metering unit face.

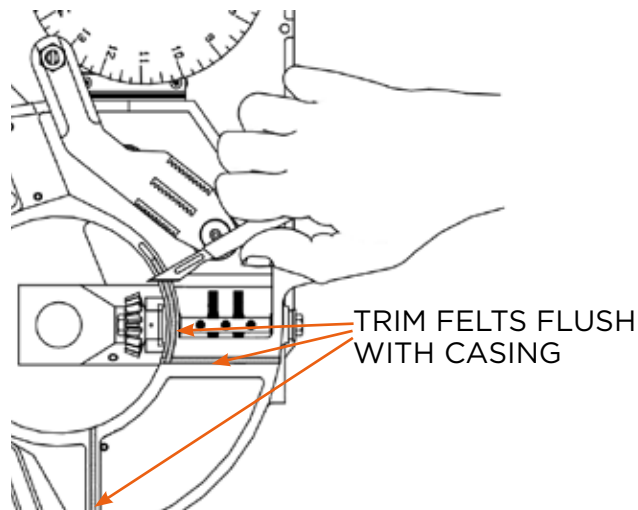

If felts are subjected to moisture they may expand out of the casting channel and clamp the seed disc. Effected felts will need trimming flush again.

17.0 METERING UNIT MAINTENANCE

17.4 GALLERY BLOCK OPTIONS

There are four variants of gallery blocks in the Stanhay range to suit any drilling requirement. See below for each of the four options available:



STANDARD GREY



4 LINE GREY



STANDARD WHITE



4 LINE WHITE

17.5 GALLERY BLOCK RIDGE REMOVAL

The diameter of the seed disc is slightly smaller than the diameter of the gallery block, so as the block wears a small ridge will develop around the outside. This ridge may eventually grip the disc and make it difficult to turn which could result in damage to the disc occurring. To remove this ridge and extend the life of the gallery block use a sharp utility knife as shown in the image. Take care not to score or damage the face of the block.

REMOVE RIDGE
AROUND BLOCK

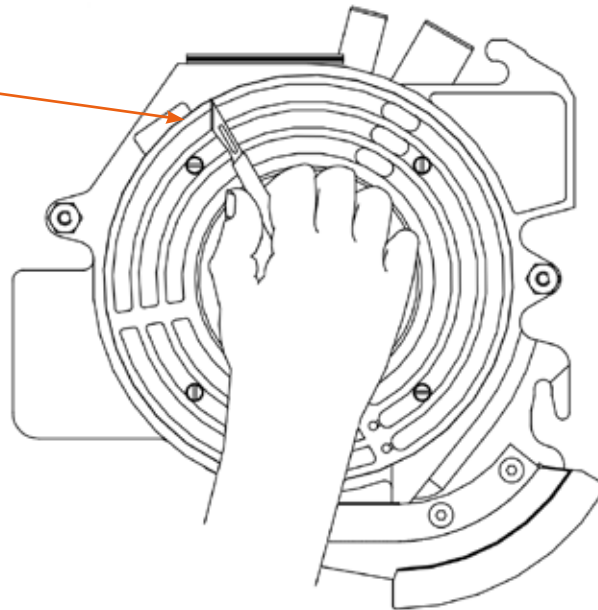

Silicone **SHOULD NOT** be used to seal the gallery block.

17.0 METERING UNIT MAINTENANCE

17.6 GALLERY BLOCK REPLACEMENT

The air gallery block is a sacrificial part and as such will need replacing after a period of time to ensure that optimum performance is maintained. As a rule of thumb the gallery block should be changed when the seed splitter cannot seal against the face of the disc; this then allows seed to go past the splitter guides causing poor or sporadic seed placement. Follow the instructions below to fit a new block:

- To remove the gallery block from the unit undo the four screws and pull block from the casting.
- Thoroughly clean the drive side body of all residual debris.
- Apply a thin bead of gasket compound such as 'Hylamar Blue' to the back of the new gallery block and refit into casting body.

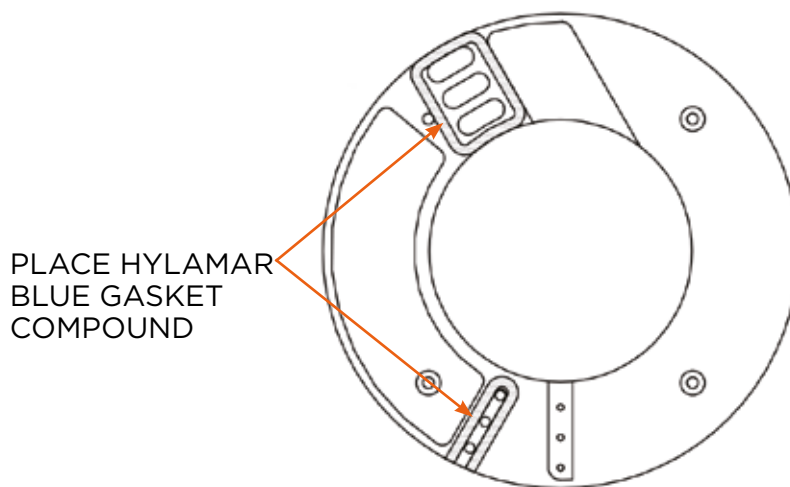

17.7 GALLERY BLOCK REPLACEMENT- GASKET VARIANT

Where you have a white gallery block with a paper gasket (A) behind follow these instructions in place of those above.

- To remove the gallery block from the unit undo the four screws and pull block and paper gasket from the casting.
- Thoroughly clean the drive side body of all residual debris.
- Check paper gasket for wear and replace if necessary.
- Place the paper gasket into the casting body ensuring all holes are aligned then refit the new gallery block on top.

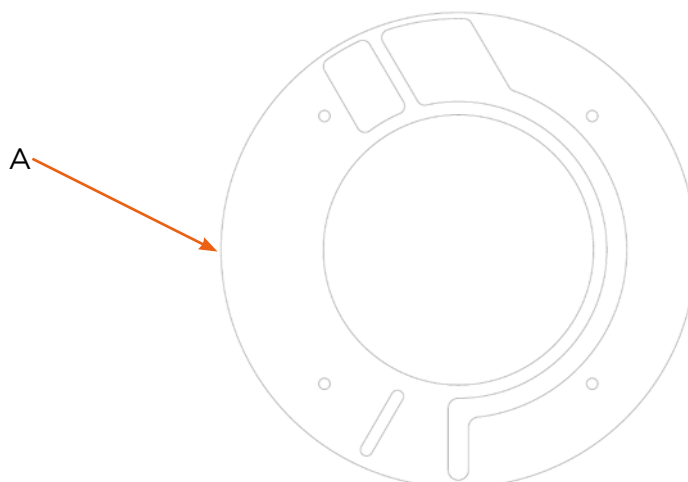

17.0 METERING UNIT MAINTENANCE

17.8 SPLITTER REPLACEMENT

- To replace the seed splitter undo the two fasteners at point (A) and (B) before removing the splitter.
- Fit new splitter into place.
- Lay a straight edge along the splitter to make sure the splitters are flush with the casting or slightly below.

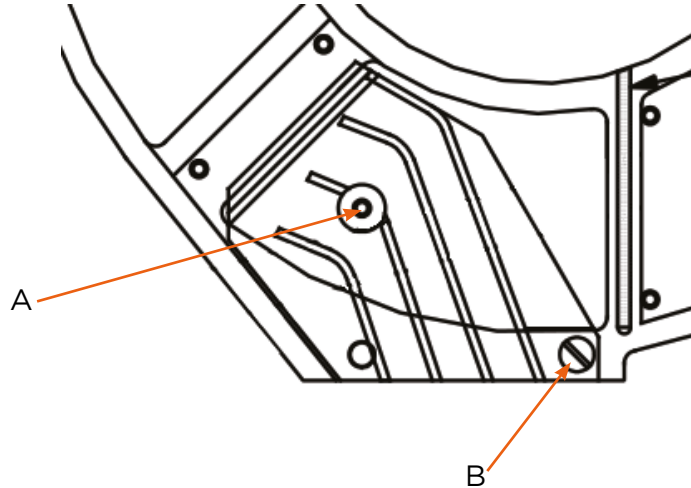

17.9 SEED SPLITTER OPTIONS

The three variants of seed splitters available from Stanhay are as follows:



4 LINE SPLITTER



RED BEET SEED SPLITTER



STANDARD SEED SPLITTER

17.0 METERING UNIT MAINTENANCE

17.10 SINGULATOR REPLACEMENT

The standard multi-line singulator will handle the majority of seed up to 3 line, however for certain specialist or large seed it may be necessary to fit an alternative singulator.

- To change the singulator remove handwheel (B), lift off setting arm (C) and setting cam (D).
- Remove retaining cap (A) if fitted.
- Lift off singulator and unhook spring (E).
- When re-assembling, ensure that springs (F) are located over the bosses on the underside of the singulator.

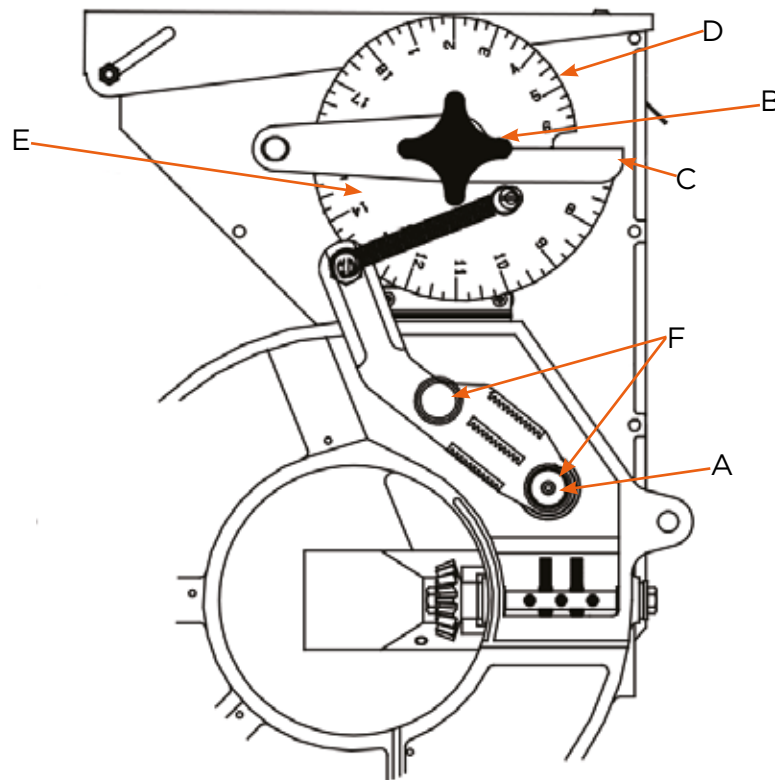

17.11 SINGULATOR OPTIONS

The singulator options available from Stanhay are shown below:

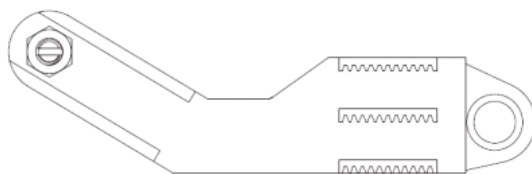

STANDARD MULTI-LINE SINGULATOR

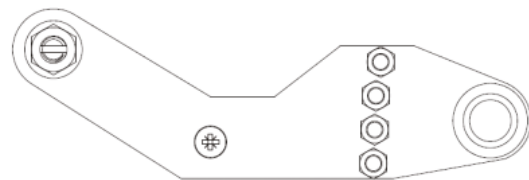

4 LINE SINGULATOR

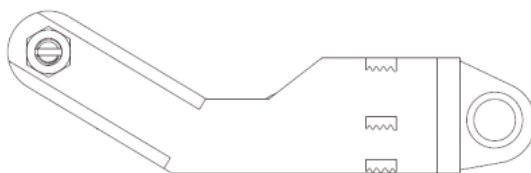

RED BEET SINGULATOR

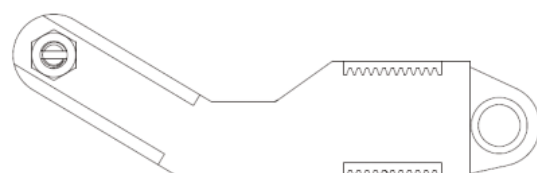

SINGLE LINE SINGULATOR

18.0 FAN MAINTENANCE

18.1 FAN BELT TENSION AND BELT REPLACEMENT

Important: the belt within the fan unit must be checked to ensure it is at the correct tension before work. New fans will have had their belts factory set and tested so will not need tensioning prior to work.

- Loosen the 4 M8 nuts and remove the guard.
- Slacken off bottom bearing housing nuts (A) until the PTO pulley moves under its own weight.
- Tighten the adjusting screw nuts (B) whilst rotating the PTO pulley by hand until the slack is taken out of the belt.
- For the 17 rib fan, tighten the adjuster screw nut a further 0.8 turns (5 flats on the nut) whilst turning the PTO pulley. For the 26 rib fan, tighten the adjuster screw nut a further 1.5 turns (9 flats in the nut) whilst turning the PTO pulley.
- The belt will now be under the correct tension. Lock the adjuster nut (B) and tighten the bottom bearing housing mounting nuts and bolts (A).

To replace the fan belt:

If the fan belt becomes worn or damaged it is recommended that it is replaced. To replace the fan belt follow the instructions below.

- Remove the guard and slacken off the bottom bearing housing as above.
- Loosen the nuts on the adjuster screw (B) to the end of their travel.
- Slide the bearing housing and PTO pulley (C) up until the belt can easily be removed; if the belt is proving difficult to remove unwind the nuts on the adjuster screw further to give the bearing housing more upward travel.
- Once the old belt is removed fit the new belt – ensure that the ribs on the new belt is fully aligned with the grooves on the impeller shaft.
- With the belt fitted follow the belt tensioning instructions above and replace the cover.



Before attempting to replace the belt ensure that the driveline to the tractor is removed and the fan has come to a complete stop.

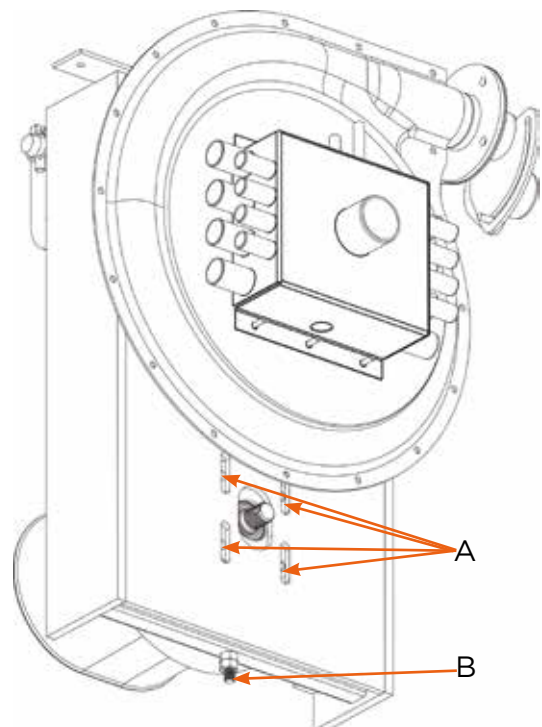
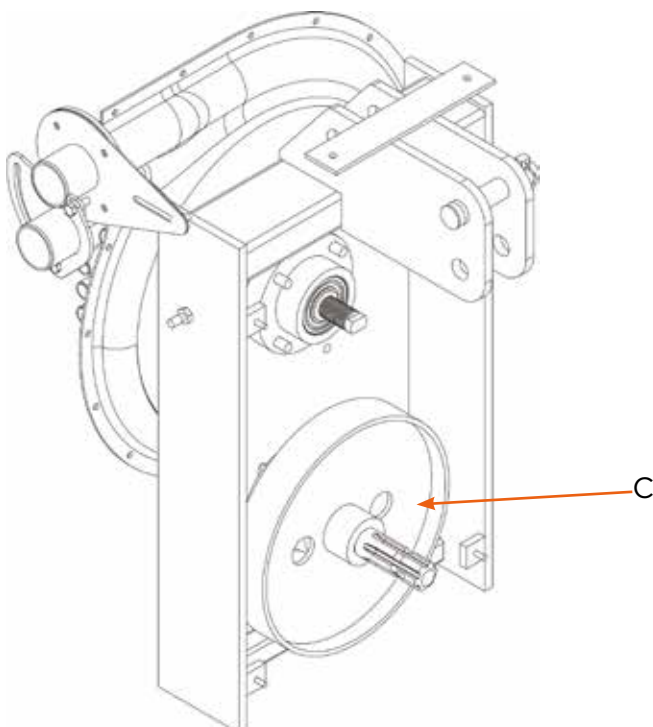

18.0 FAN MAINTENANCE

18.2 IMPELLER CHECKING

During the course of a fans life it may be necessary to check the fan impeller for damage and wear if it is not performing satisfactorily or making noises not associated with normal operation. To check the impeller follow the steps below:

- Disconnect PTO from tractor.
- Remove the outer casing of the fan by undoing all of the bolts.
- Use an air line or brush to remove any dust or debris that has built up.
- Turn the fan by hand and check for any damage, misalignment, loose rivets, collapsed bearings in the impeller housing etc.



Any damaged items **MUST** be replaced before the fan is used again. Running a damaged fan may impair the performance of the machine and may cause serious injury or death if an impeller failure occurs.



If the fan does not operate correctly or begins to make noises not associated with normal operation switch off the tractor immediately and do not approach the fan until it has come to a complete stop. Impeller checking must only be carried out by Stanhay trained service technicians.

18.3 BEARING EXTRACTION

During normal operation the fan is low maintenance. However over time the bearings in the top and bottom housing can reach the end of their serviceable life. It is important to change these before they reach the point of failure so not to cause damage to the fan itself.

To change the bearings follow the instructions below:

18.3.1 TOP BEARING HOUSING

- Slacken bottom housing and remove fan belt.
- Remove front casing from fan to reveal the impeller and retaining castle nut.
- Undo castle nut and remove impeller.
- The impeller shaft can now be removed from the tractor side of the fan.
- Replace bearings - it may be easier to perform this task with the top bearing housing removed from the fan casing.
- Reassemble fan remembering to tension fan belt correctly

18.3.2 BOTTOM BEARING HOUSING

- Slacken bottom housing and remove fan belt
- Fully remove nuts holding the bottom bearing housing and adjuster screw
- Remove PTO pulley and bearing house assembly from fan casing.
- Undo castle nut at the back of the bearing housing and remove the PTO pulley and drive shaft from bearing housing .
- Remove damaged or failed bearings.
- Fit new bearing/bearings by applying loctite to the outer race and press bearing into place.
- Reassemble bearing housing into the fan casing and fit the PTO pulley and shaft.
- Refit the drive belt and tension correctly before use.

19.0 LANDWHEEL MAINTENANCE

19.1 CHECKING THE WHEELS/ TYRES

Defective tyres and / or the wrong tyre pressure reduce the operating safety.

Only carry out the following checks when the engine is switched off. Pay attention that the machine is safely parked and secured against rolling away.

- Check the tyres daily for signs of damage or obvious low pressure – tyres must be inflated to 48PSI to maintain correct seed spacing.
- Measure the tyre pressure with accurate test equipment.

**DANGER!**

There is a risk of bursting if the tyre pressure is too high!

If a tyre bursts during inflating, flying parts can hit and injure persons in the vicinity.

- Do not exceed the specified air pressure when inflating the tyres!

**DANGER!**

The risk of accidents is greatly increased if the tyres are under inflated!

Under inflation can lead to damage of the tyres and incorrect seed spacing. If the tyre pressure is too low, the tyre may come off the wheel rim whilst in operation!

- Check the tyres daily for signs of obvious low pressure!
- Measure the tyre pressure with accurate test equipment once a week!

19.2 MAINTENANCE/ REPAIR WORK ON WHEELS/ TYRES

The following must be observed during maintenance or repair work:

- Do not work on the wheels unless the engine is switched off. Remove the ignition key.
- Prior to any work on the wheels, attention must be paid that the machine is securely parked and has been secured against rolling away (apply wedges if necessary).
- Working under an unpropped machine is prohibited.
- There is a risk of bursting if the tyre pressure is too high! Always observe the correct tyre pressure.

19.0 LANDWHEEL MAINTENANCE

19.3 TIGHTENING WHEEL NUTS/ WHEEL BOLTS

Only carry out work on the wheel nuts/wheel bolts when the engine is switched off. Pay attention that the machine is safely parked and secured against rolling away.

Sequence for tightening the wheel nuts/wheel bolts

- Always tighten the wheel nuts/wheel bolts with the specified tightening torque.

The firm seating of the screw connections on the landwheels must be checked at the following intervals:

- Before the first use under load
- After the first use under load
- After 50 operating hours
- After 100 operating hours
- Thereafter every 200 operating hours

Screw type: M14x1.5 8.8
Number of screws: 5
Tightening torque: 125 Nm



Tighten the wheel nuts diagonally using a torque spanner.

19.4 LANDWHEEL GREASE POINTS

Grease each individual landwheel at point (A) shown below. One lubrication point per landwheel.

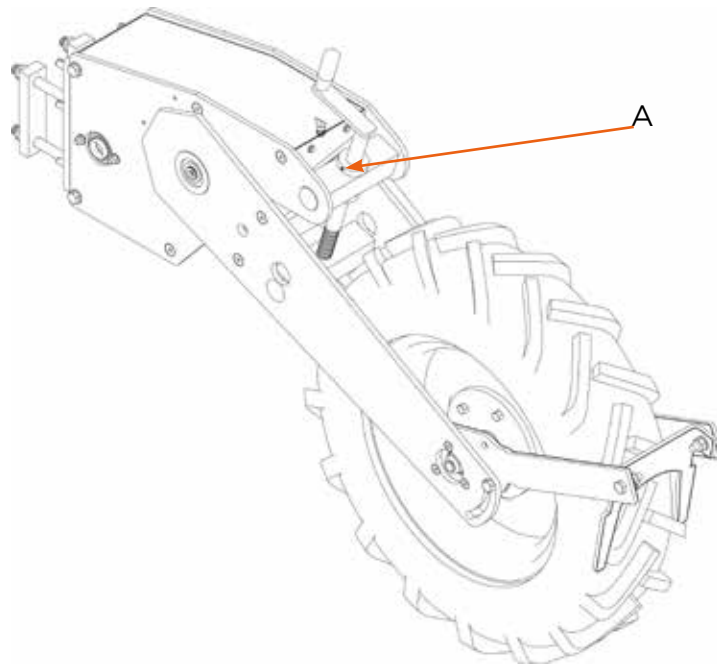

20.0 TOOLBAR MAINTENANCE

20.1 STACKER GREASE POINTS

Grease the toolbar as instructed by the diagram below. The greasing points are specified by points (G). There are 4 lubrication points per side.

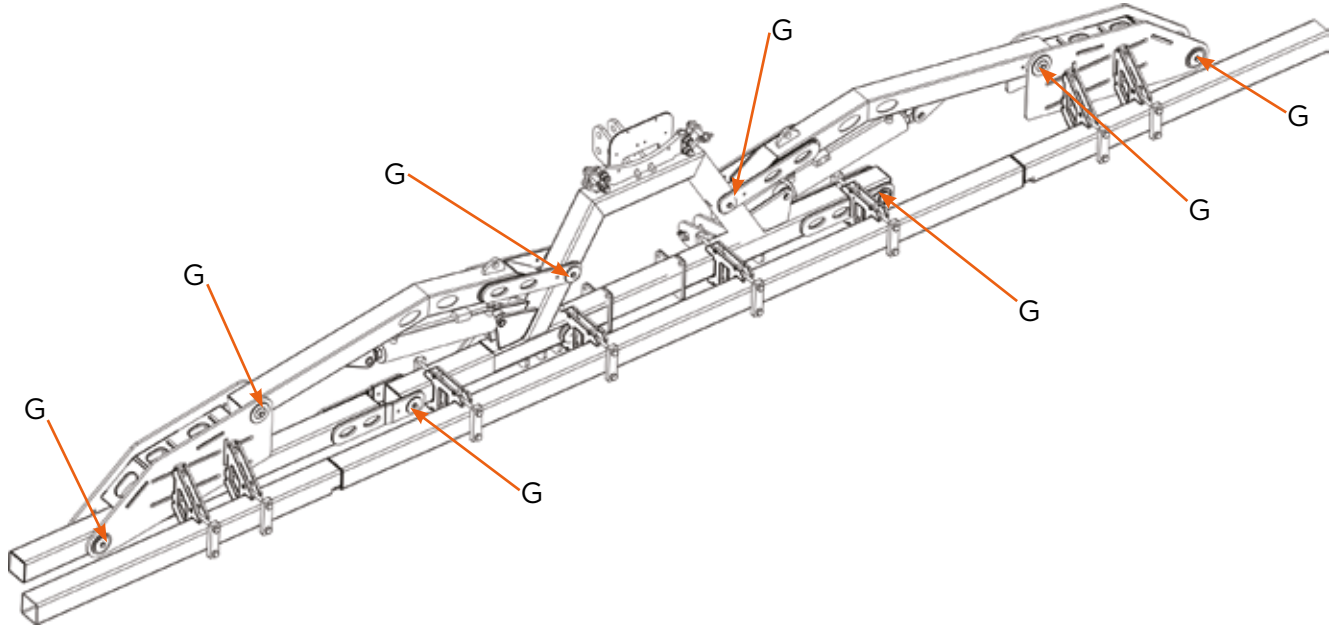

21.0 ROW UNIT MAINTENANCE

ProAir row units use maintenance free bearings at all pivot points along with a sealed flexible drive shaft meaning no periodic maintenance is required.

22.0 LOADING WORK

For loading and unloading of the machine using an overhead crane, the lifting points must be located where the symbol of the lifting hook is shown. Only use suitable lifting equipment with adequate load-carrying capabilities.

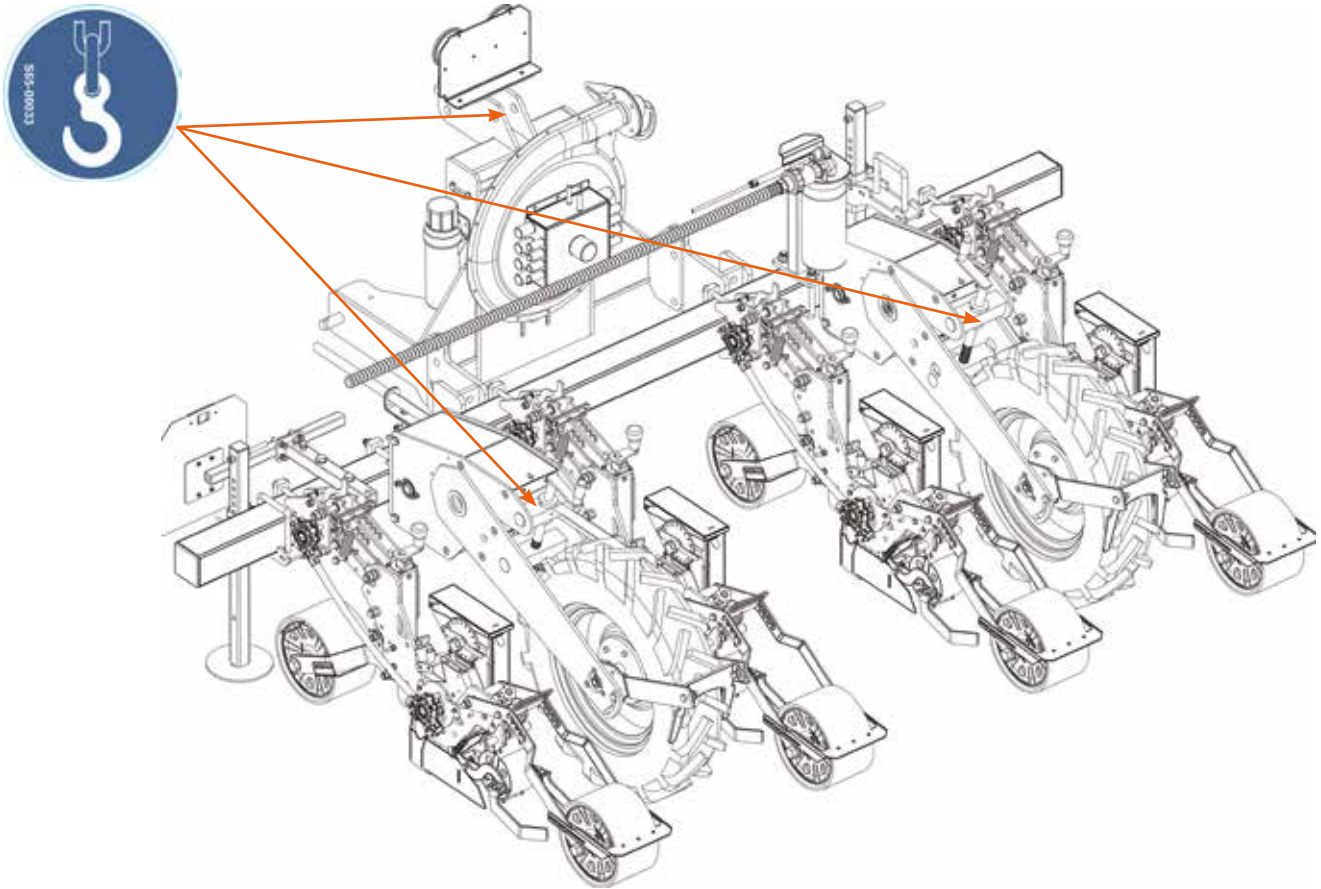

If the machine is loaded onto a transport vehicle, the machine must be secured on the transport vehicle by means of strapping to stop the machine from moving on the transport vehicle.



DANGER!

Risk of injuries by dropping machines or machine components!

A lifted load can drop when a lifting device or any lifting apparatus fails.

- Never stand or work under suspended loads. Instruct all people in the vicinity of loading the drill to keep clear of the danger zone.



DANGER!

Risk of crushing by swinging or dropping load!

Suspended loads have a risk of swinging or dropping when being loaded or unloaded. People within the vicinity of the suspended load are at risk of being hit by the suspended load.

- Attach the machine to the correct loading points only.
- Attachment of the loads and the use of lifting equipment should only be entrusted by competent operators.

23.0 DECOMMISSIONING AND DISPOSAL

23.1 DECOMMISSIONING

If the end of the useful life of machine or its components is reached and these are handed over for scrapping, the components must be disposed of in the correct manner. At the same time, the regulations of the local authorities must be adhered to.

23.2 DISPOSAL

The service fluids in the machine require a special type of disposal and may not get into the environment. Further information with regards to waste disposal can be gathered from the local authorities, the Stanhay dealer and Stanhay service. Do not dispose of the product carrying the symbol below (domestic waste only) at the end of their lifetime.

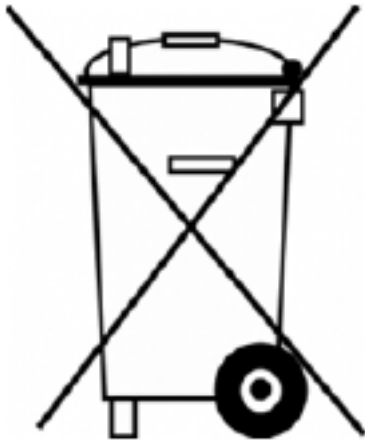

- Recycle materials used and carrying the symbol above according to their identification.
- Do not dispose of any packaging material via the domestic waste, instead recycle the materials.
- Any plastics with their material data shown on them can be recycled.
- Used batteries contain contaminants and must be taken back to the distributor, duly disposed of or handed in at a collection point. Do not dispose of used batteries via domestic waste.
- Treat service fluids such as oils, hydraulic fluids, brake fluids or fuels as special waste and dispose of in due form.
- Adhere to all country regulations and local authorities regarding recycling and disposal.

24.0 TECHNICAL DATA

PART	PROAIR
Planter Type	Air
Seed Type	Natural + Pelleted
Multi-line Capability	1-4 Lines
Hopper Capacity (Litres)	1,2,4,8
Toolbar	100mm or 180mm Square
Minimum Seed Spacing	7mm
Min/Max Seed Size	1mm-10mm
Min/Max Number of Rows Per Machine	2-18+
Minimum Row Spacing	210mm
Minimum Line Spacing	21.6mm
Approx Row Unit Weight (Kg)	40
Row Unit Length (mm)	1244
Depth Control	Infinite Control
Coverer Options	Drag or Arm
Wheel Options	Stainless/Cage/Rubber
Seed Press Wheels Available	Yes
Row Unit Down Force Adjustment	Yes
Rear Wheel Down Force Adjustment	Yes
Drive System	28 Speed Chain Drive
Tractor Requirement	Small or Large Tractor With PTO/Hydraulics
Linkage Category	CAT 2/3

PART	APPROXIMATE WEIGHT (kg)	PART	APPROXIMATE WEIGHT (kg)
17 Rib Fan	90	26 Rib Fan	110
100 Toolbar 3000mm long	45	Stacking Frame	450
Geared Landwheel	106	Support Landwheel	100
ProAir Row Unit	40	Ancillaries (per 1m)	0.5
Parking Stand	7.5	PTO Shaft	10

25.0 TROUBLESHOOTING

VACUUM READING DROPS	
Reason	Solution
No seed in hopper.	Fill hoppers and re-prime seed discs.
Seed disc(s) not holding vacuum or vibrating.	Check for damage or wear. Scores and gouges will also cause problems/vibration.
Seed or contamination between disc and gallery block.	Clean units thoroughly check for blocked holes in seed discs etc.
Damaged agitator.	Check rubber fingers are securely fitted and repair or replace as necessary.
Vacuum hose disconnected or damaged.	Check hoses for free play and reconnect or replace as necessary.
Fan unit not driving.	Check PTO shaft or hydraulic motor are driving Remove drive cover and check belt for tension and damage. Check that top or bottom pulleys rotate freely and bearings have not seized or collapsed.
UNITS NOT PICKING UP SEED	
Reason	Solution
Seed disc holes too small for seed size.	Check recommended hole size.
Singulators incorrectly set.	Back off, check seed pick up and reset correctly.
Units turning too quickly.	Check forward speed/gear recommendations and reset as necessary.
Incorrect vacuum or pressure levels	Check recommendations and reset.
Seed discs worn, damaged or with blocked holes.	Clean units thoroughly and clean out any blocked holes in seed discs. Check discs are holding vacuum.
Unit vacuum and pressure hoses incorrectly fitted.	Check and re-fit, if necessary.
Insufficient seed agitation or incorrect agitator fitted.	Check rubber fingers are securely fitted, and repair or replace as necessary. Check that agitator rotates freely.
SEED DISC HOLES CONSTANTLY BLOCKING	
Reason	Solution
Incorrect hole size.	Check recommendations.
Dirty or poor quality seed.	The most common cause of blocked holes. Large clean seed should be used if possible for best performance.

25.0 TROUBLESHOOTING

UNITS NOT DROPPING SEED CORRECTLY	
Reason	Solution
Insufficient pressure and/or too much vacuum causing small seed to be sucked back up into unit.	Check recommendation and reset accordingly.
Seed splitters and/or coulters incorrectly fitted.	See fitting instructions and re-adjust.
Dirty, damp or blocked coulters seed chutes.	Clean seed chutes and if coulters are blocked, investigate cause and rectify.
Seed disc being clamped by centre of unit hopper side. Disc not running smoothly or seizing.	Remove disc and clean with fine abrasive. Remove vacuum gallery block. Seal and refit using suitable sealant e.g. Hylamar Blue.
SEED LEAKING AT COULTER OR CHUTE	
Reason	Solution
Metering unit castings fitted incorrectly.	Ensure casting faces are clean. Refit and lightly tighten conical nuts.
Chute not aligning with seed splitter.	Loosen chute on coulters when fitted to metering unit and realign with splitter outlets.
INCONSISTENT SINGULATION	
Reason	Solution
Singulator not pressing flat onto disc.	Flick singulator arm several times, then recalibrate unit.
Worn singulator arm.	Remove singulator arm, blacken all three wearing faces with felt tip pen, grip firmly and rub on fine abrasive paper positioned on a flat solid surface until all black ink is removed. If severely worn or damaged, replace with new. Refit, and recalibrate unit.
EXCESSIVE VACUUM REQUIREMENTS	
Reason	Solution
Worn or damaged seed discs or air gallery block.	Check and replace offending item.
Incorrect hole size in seed discs.	Refer to the Stanhay Air Drill Users Guide for correct hole size or consult a Stanhay representative.
Excessive disc speed.	Check forward speed/gear recommendations and reset as necessary.
Singulators set too aggressively.	Recalibrate units - avoid the temptation to set singulators aggressively as the occasional double seed is unavoidable especially on natural seed.

26.0 SEED SPACING CALCULATIONS

26.1 BED SYSTEMS



$$\text{Average Seed Spacing (mm)} = \frac{10,000,000 \times \text{Total Lines on Bed}}{\text{Tractor Wheel Track (m)} \times \text{Seeds/Hectare}}$$

$$\text{Seeds/ Hectare} = \frac{10,000,000 \times \text{Total Lines on Bed}}{\text{Tractor Wheel Track (m)} \times \text{Average seed spacing(mm)}}$$

$$\text{Average Seed Spacing (in)} = \frac{6,272,640 \times \text{Total Lines on Bed}}{\text{Tractor Wheel Track (in)} \times \text{Seeds/Acre}}$$

$$\text{Seeds/Acre} = \frac{6,272,640 \times \text{Total Lines on Bed}}{\text{Tractor Wheel Track (in)} \times \text{Average seed spacing (in)}}$$

26.2 FIELD SYSTEMS



$$\text{Average Seed Spacing(mm)} = \frac{1,000,000,000 \times \text{Lines/Row}}{\text{Row Width (cm)} \times \text{Seeds/Hectare}}$$

$$\text{Seeds/Hectare} = \frac{1,000,000,000 \times \text{Lines/Row}}{\text{Row Width (cm)} \times \text{Average seed spacing(mm)}}$$

$$\text{Average Seed Spacing (in)} = \frac{6,272,640 \times \text{Lines/Row}}{\text{Row Width (in)} \times \text{Seeds/Acre}}$$

$$\text{Seeds/Acre} = \frac{6,272,640 \times \text{Lines/Row}}{\text{Row Width (in)} \times \text{Average seed spacing(in)}}$$

27.0 SPACING CHARTS

27.1 SPACING CHARTS FOR PROAIR (19:24 PRIMARY DRIVE)

	MM. INS.						MM. INS.						FORWARD SPEED TO ROTATE UNIT AT 25 RPM		
	12	24	48	72	96	120	144	120	96	72	48	24	MAX KPH	MAX MPH	
151	142.04	5.59	71.02	2.80	35.51	1.40	23.67	0.93	17.75	0.70	14.20	0.56	11.84	0.47	1.59
161	151.51	5.96	37.88	1.49	25.25	0.99	25.25	0.99	18.94	0.75	15.15	0.60	12.63	0.50	1.69
171	160.98	6.34	40.24	1.58	26.83	1.06	26.83	1.06	20.12	0.79	16.10	0.63	13.41	0.53	1.80
181	170.45	6.71	42.61	1.68	28.41	1.12	28.41	1.12	21.31	0.84	17.04	0.67	14.20	0.56	1.91
201	179.92	7.08	44.98	1.77	29.99	1.18	29.99	1.18	22.49	0.89	17.99	0.71	14.99	0.59	2.01
211	189.39	7.46	47.35	1.86	31.56	1.24	31.56	1.24	23.67	0.93	18.94	0.75	15.78	0.62	2.12
221	198.86	7.83	49.71	1.96	33.14	1.30	33.14	1.30	24.86	0.98	19.89	0.78	16.57	0.65	2.22
19:24	208.32	8.20	52.08	2.05	34.72	1.37	34.72	1.37	26.04	1.03	20.83	0.82	17.36	0.68	2.33
17/16	213.89	8.42	53.47	2.11	35.65	1.40	35.65	1.40	26.74	1.05	21.39	0.84	17.82	0.70	2.39
17/17	227.26	8.95	56.82	2.24	37.88	1.49	37.88	1.49	28.41	1.12	22.73	0.89	18.94	0.75	2.54
17/18	240.63	9.47	60.16	2.37	40.11	1.58	40.11	1.58	30.08	1.18	24.06	0.95	20.05	0.79	2.69
17/19	254.00	10.00	63.50	2.50	42.33	1.67	42.33	1.67	31.75	1.25	25.40	1.00	21.17	0.83	2.84
17/20	267.37	10.53	66.84	2.63	44.56	1.75	44.56	1.75	33.42	1.32	26.74	1.05	22.28	0.88	2.99
17/21	280.74	11.05	70.18	2.76	46.79	1.84	46.79	1.84	35.09	1.38	28.07	1.11	23.39	0.92	3.14
17/22	294.11	11.58	73.53	2.89	49.02	1.93	49.02	1.93	36.76	1.45	29.41	1.16	24.51	0.96	3.29
13/15	262.23	10.32	65.56	2.58	43.70	1.72	43.70	1.72	32.78	1.29	26.22	1.03	21.85	0.86	2.93
13/17	297.19	11.70	74.30	2.93	49.53	1.95	49.53	1.95	37.15	1.46	29.72	1.17	24.77	0.98	3.32
13/18	314.67	12.39	78.67	3.10	52.45	2.06	52.45	2.06	39.33	1.55	31.47	1.24	26.22	1.03	3.52
13/19	332.15	13.08	83.04	3.27	55.36	2.18	55.36	2.18	41.52	1.63	33.22	1.31	27.68	1.09	3.71
13/20	349.64	13.77	87.41	3.44	58.27	2.29	58.27	2.29	43.70	1.72	34.96	1.38	29.14	1.15	3.91
13/21	367.12	14.45	91.78	3.61	61.19	2.41	61.19	2.41	45.89	1.81	36.71	1.45	30.59	1.20	4.11
13/22	384.60	15.14	96.15	3.79	64.10	2.52	64.10	2.52	48.07	1.89	38.46	1.51	32.05	1.26	4.30
11/15	309.90	12.20	77.48	3.05	51.65	2.03	51.65	2.03	38.74	1.53	30.99	1.22	25.83	1.02	3.47
11/18	371.89	14.64	92.97	3.66	61.98	2.44	61.98	2.44	46.49	1.83	37.19	1.46	30.99	1.22	4.16
11/19	392.55	15.45	98.14	3.86	65.42	2.58	65.42	2.58	49.07	1.93	39.25	1.55	32.71	1.29	4.39
11/20	413.21	16.27	103.30	4.07	68.87	2.71	68.87	2.71	51.65	2.03	41.32	1.63	34.43	1.36	4.62
11/21	433.87	17.08	108.47	4.27	72.31	2.85	72.31	2.85	54.23	2.14	43.39	1.71	36.16	1.42	4.85
11/22	454.53	17.89	113.63	4.47	75.75	2.98	75.75	2.98	56.82	2.24	45.45	1.79	37.88	1.49	5.08

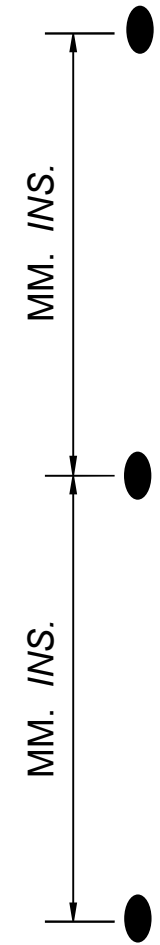

S6500021

(1:1 Flexidrive) Seed Spacing / Gear Chart - Adjustable Height Chain Drive Landwheel
19:24 Primary Drive



27.0 SPACING CHARTS

27.2 SPACING CHARTS FOR PROAIR (19:40 PRIMARY DRIVE)

	MM. INS.							MM. INS.		FORWARD SPEED TO ROTATE UNIT AT 25 RPM	
	12	24	48	72	96	120	144	MAX KPH	MAX MPH		
24T 17T 13T 11T	236.73	118.37	59.18	39.46	29.59	23.67	19.73	4.26	2.65		
	252.51	126.26	63.13	42.09	31.56	25.25	21.04	4.54	2.82		
	268.30	134.15	67.07	44.72	33.54	26.83	22.36	4.83	3.00		
	284.08	142.04	71.02	47.35	35.51	28.41	23.67	5.11	3.18		
	299.86	149.93	74.97	49.98	37.48	29.99	24.99	5.40	3.35		
	315.64	157.82	78.91	52.61	39.46	31.56	26.30	5.68	3.53		
	331.43	165.71	82.86	55.24	41.43	33.14	27.62	5.96	3.71		
	347.21	173.60	86.80	57.87	43.40	34.72	28.93	6.25	3.88		
	356.49	178.25	89.12	59.42	44.56	35.65	29.71	6.42	3.99		
	378.77	189.39	94.69	63.13	47.35	37.88	31.56	6.82	4.24		
	401.05	200.53	100.26	66.84	50.13	40.11	33.42	7.22	4.49		
	423.33	211.67	105.83	70.56	52.92	42.33	35.28	7.62	4.73		
	445.61	222.81	111.40	74.27	55.70	44.56	37.13	8.02	4.98		
	467.89	233.95	116.97	77.98	58.49	46.79	38.99	8.42	5.23		
	490.18	245.09	122.54	81.70	61.27	49.02	40.85	8.82	5.48		
	437.04	218.52	109.26	72.84	54.63	43.70	36.42	7.87	4.89		
	495.32	247.66	123.83	82.55	61.91	49.53	41.28	8.91	5.54		
	524.45	262.23	131.11	87.41	65.56	52.45	43.70	9.44	5.87		
	553.59	276.79	138.40	92.26	69.20	55.36	46.13	9.96	6.19		
	582.73	291.36	145.68	97.12	72.84	58.27	48.56	10.49	6.52		
	611.86	305.93	152.97	101.98	76.48	61.19	50.99	11.01	6.84		
	641.00	320.50	160.25	106.83	80.12	64.10	53.42	11.54	7.17		
	516.51	258.25	129.13	86.08	64.56	51.65	43.04	9.30	5.78		
	619.81	309.90	154.95	103.30	77.48	61.98	51.65	11.16	6.93		
	654.24	327.12	163.56	109.04	81.78	65.42	54.52	11.77	7.32		
	688.68	344.34	172.17	114.78	86.08	68.87	57.39	12.39	7.70		
	723.11	361.56	180.78	120.52	90.39	72.31	60.26	13.01	8.09		
	757.54	378.77	189.39	126.26	94.69	75.75	63.13	13.63	8.47		

S6500022

(1:1 Flexdrive) Seed Spacing / Gear Chart - Adjustable Height Chain Drive Landwheel
19:40 Primary Drive



27.0 SPACING CHARTS

27.3 SPACING CHARTS FOR PROAIR (19:24 PRIMARY DRIVE)

	MM. INS.						MM. INS.						FORWARD SPEED TO ROTATE UNIT AT 25 RPM		
	12	24	48	72	96	120	144	120	96	72	48	24	12	MAX KPH	MAX MPH
22T															
21T															
20T															
19T															
18T															
17T															
16T															
15T															
24T 17T 13T 11T	215.21	8.47	107.61	4.24	53.80	2.12	35.87	1.41	26.90	1.06	21.52	0.85	17.93	0.71	2.41
24/15	229.56	9.04	114.78	4.52	57.39	2.26	38.26	1.51	28.69	1.13	22.96	0.90	19.13	0.75	2.57
24/16	243.91	9.60	121.95	4.80	60.98	2.40	40.65	1.60	30.49	1.20	24.39	0.96	20.33	0.80	2.73
24/17	258.25	10.17	129.13	5.08	64.56	2.54	43.04	1.69	32.28	1.27	25.83	1.02	21.52	0.85	2.89
24/18	272.60	10.73	136.30	5.37	68.15	2.68	45.43	1.79	34.08	1.34	27.26	1.07	22.72	0.89	3.05
24/19	286.95	11.30	143.47	5.65	71.74	2.82	47.82	1.88	35.87	1.41	28.69	1.13	23.91	0.94	3.21
24/20	301.30	11.86	150.65	5.93	75.32	2.97	50.22	1.98	37.66	1.48	30.13	1.19	25.11	0.99	3.37
24/21	315.64	12.43	157.82	6.21	78.91	3.11	52.61	2.07	39.46	1.55	31.56	1.24	26.30	1.04	3.53
24/22	324.08	12.76	162.04	6.38	81.02	3.19	54.01	2.13	40.51	1.59	32.41	1.28	27.01	1.06	3.62
17/16	344.34	13.56	172.17	6.78	86.08	3.39	57.39	2.26	43.04	1.69	34.43	1.36	28.69	1.13	3.85
17/17	364.59	14.35	182.30	7.18	91.15	3.59	60.77	2.39	45.57	1.79	36.46	1.44	30.38	1.20	4.08
17/18	384.85	15.15	192.42	7.58	96.21	3.79	64.14	2.53	48.11	1.89	38.48	1.52	32.07	1.26	4.30
17/19	405.10	15.95	202.55	7.97	101.28	3.99	67.52	2.66	50.64	1.99	40.51	1.59	33.76	1.33	4.53
17/20	425.36	16.75	212.68	8.37	106.34	4.19	70.89	2.79	53.17	2.09	42.54	1.67	35.45	1.40	4.76
17/21	445.61	17.54	222.81	8.77	111.40	4.39	74.27	2.92	55.70	2.19	44.56	1.75	37.13	1.46	4.98
17/22	397.31	15.64	198.66	7.82	99.33	3.91	66.22	2.61	49.66	1.96	39.73	1.56	33.11	1.30	4.44
13/15	450.29	17.73	225.14	8.86	112.57	4.43	75.05	2.95	56.29	2.22	45.03	1.77	37.52	1.48	5.04
13/17	476.78	18.77	238.39	9.39	119.19	4.69	79.46	3.13	59.60	2.35	47.68	1.88	39.73	1.56	5.33
13/18	503.26	19.81	251.63	9.91	125.82	4.95	83.88	3.30	62.91	2.48	50.33	1.98	41.94	1.65	5.63
13/19	529.75	20.86	264.88	10.43	132.44	5.21	88.29	3.48	66.22	2.61	52.98	2.09	44.15	1.74	5.92
13/20	556.24	21.90	278.12	10.95	139.06	5.47	92.71	3.65	69.53	2.74	55.62	2.19	46.35	1.82	6.22
13/21	582.73	22.94	291.36	11.47	145.68	5.74	97.12	3.82	72.84	2.87	58.27	2.29	48.56	1.91	6.52
13/22	469.55	18.49	234.78	9.24	117.39	4.62	78.26	3.08	58.69	2.31	46.96	1.85	39.13	1.54	5.25
11/15	563.46	22.18	281.73	11.09	140.87	5.55	93.91	3.70	70.43	2.77	56.35	2.22	46.96	1.85	6.30
11/18	594.77	23.42	297.38	11.71	148.69	5.85	99.13	3.90	74.35	2.93	59.48	2.34	49.56	1.95	6.65
11/19	626.07	24.65	313.03	12.32	156.52	6.16	104.34	4.11	78.26	3.08	62.61	2.46	52.17	2.05	7.00
11/20	657.37	25.88	328.69	12.94	164.34	6.47	109.56	4.31	82.17	3.24	65.74	2.59	54.78	2.16	7.35
11/21	688.68	27.11	344.34	13.56	172.17	6.78	114.78	4.52	86.08	3.39	68.87	2.71	57.39	2.26	7.70
11/22															

(1:1.5 Flexdrive) Seed Spacing / Gear Chart - Adjustable Height Chain Drive Landwheel



S6500043

27.0 SPACING CHARTS

27.4 SPACING CHARTS FOR PROAIR (19:40 PRIMARY DRIVE)

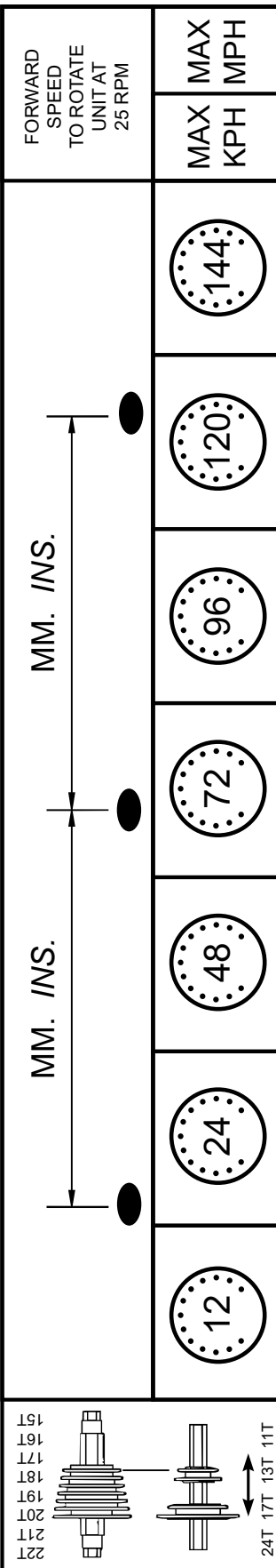
	MM. INS.							FORWARD SPEED TO ROTATE UNIT AT 25 RPM								
	12	24	48	72	96	120	144	MAX KPH	MAX MPH							
24/15	358.69	14.12	179.34	7.06	89.67	3.53	59.78	2.35	44.84	1.77	35.87	1.41	29.89	1.18	6.46	4.01
24/16	382.60	15.06	191.30	7.53	95.65	3.77	63.77	2.51	47.82	1.88	38.26	1.51	31.88	1.26	6.89	4.28
24/17	406.51	16.00	203.26	8.00	101.63	4.00	67.75	2.67	50.71	2.00	40.65	1.60	33.88	1.33	7.32	4.55
24/18	430.42	16.95	215.21	8.47	107.61	4.24	71.74	2.82	53.80	2.12	43.04	1.69	35.87	1.41	7.75	4.81
24/19	454.34	17.89	227.17	8.94	113.58	4.47	75.72	2.98	56.79	2.24	45.43	1.79	37.86	1.49	8.18	5.08
24/20	478.25	18.83	239.12	9.41	119.56	4.71	79.71	3.14	59.78	2.35	47.82	1.88	39.85	1.57	8.61	5.35
24/21	502.16	19.77	251.08	9.89	125.54	4.94	83.69	3.30	62.77	2.47	50.22	1.98	41.85	1.65	9.04	5.62
24/22	526.07	20.71	263.04	10.36	131.52	5.18	87.68	3.45	65.76	2.59	52.61	2.07	43.84	1.73	9.47	5.88
17/16	540.14	21.27	270.07	10.63	135.03	5.32	90.02	3.54	67.52	2.66	54.01	2.13	45.01	1.77	9.72	6.04
17/17	573.90	22.59	286.95	11.30	143.47	5.65	95.65	3.77	71.74	2.82	57.39	2.26	47.82	1.88	10.33	6.42
17/18	607.66	23.92	303.83	11.96	151.91	5.98	101.28	3.99	75.96	2.99	60.77	2.39	50.64	1.99	10.94	6.80
17/19	641.41	25.25	320.71	12.63	160.35	6.31	106.90	4.21	80.18	3.16	64.14	2.53	53.45	2.10	11.54	7.17
17/20	675.17	26.58	337.59	13.29	168.79	6.65	112.53	4.43	84.40	3.32	67.52	2.66	56.26	2.22	12.15	7.55
17/21	708.93	27.91	354.47	13.96	177.23	6.98	118.16	4.65	88.62	3.49	70.89	2.79	59.08	2.33	12.76	7.93
17/22	742.69	29.24	371.35	14.62	185.67	7.31	123.78	4.87	92.84	3.65	74.27	2.92	61.89	2.44	13.37	8.31
13/15	662.19	26.07	331.09	13.04	165.55	6.52	110.36	4.35	82.77	3.26	66.22	2.61	55.18	2.17	11.92	7.41
13/17	750.48	29.55	375.24	14.77	187.62	7.39	125.08	4.92	93.81	3.69	75.05	2.95	62.54	2.46	13.51	8.39
13/18	794.63	31.28	397.31	15.64	198.66	7.82	132.44	5.21	99.33	3.91	79.46	3.13	66.22	2.61	14.30	8.89
13/19	838.77	33.02	419.39	16.51	209.69	8.26	139.80	5.50	104.85	4.13	83.88	3.30	69.90	2.75	15.10	9.38
13/20	882.92	34.76	441.46	17.38	220.73	8.69	147.15	5.79	110.36	4.35	88.29	3.48	73.58	2.90	15.89	9.87
13/21	927.06	36.50	463.53	18.25	231.77	9.12	154.51	6.08	115.88	4.56	92.71	3.65	77.26	3.04	16.69	10.37
13/22	971.21	38.24	485.61	19.12	242.80	9.56	161.87	6.37	121.40	4.78	97.12	3.82	80.93	3.19	17.48	10.86
11/15	782.59	30.81	391.29	15.41	195.65	7.70	130.43	5.14	97.82	3.85	78.26	3.08	65.22	2.57	14.08	8.75
11/18	939.10	36.97	469.55	18.49	234.78	9.24	156.52	6.16	117.39	4.62	93.91	3.70	78.26	3.08	16.90	10.50
11/19	991.28	39.03	495.64	19.51	247.82	9.76	165.21	6.50	123.91	4.88	99.13	3.90	82.61	3.25	17.84	11.09
11/20	1043.45	41.08	521.72	20.54	260.86	10.27	173.91	6.85	130.43	5.14	104.34	4.11	86.95	3.42	18.78	11.67
11/21	1095.62	43.13	547.81	21.57	273.91	10.78	182.60	7.19	136.95	5.39	109.56	4.31	91.30	3.59	19.72	12.25
11/22	1147.79	45.19	573.90	22.59	286.95	11.30	191.30	7.53	143.47	5.65	114.78	4.52	95.65	3.77	20.66	12.84

S6500044

(1:1.5 Flexidrive) Seed Spacing / Gear Chart - Adjustable Height Chain Drive Landwheeler 19:40 Primary Drive

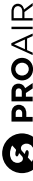



STANHAY WEBB LTD
BCS HOUSE
PINFOLD ROAD
BOURNE
PE10 9HT
UK

WWW.STANHAY.COM
S66-00001

VERSION 1.6 JULY 2020

Place dealer address here: