

Model 140

7 TON FARM WAGON

P-1514

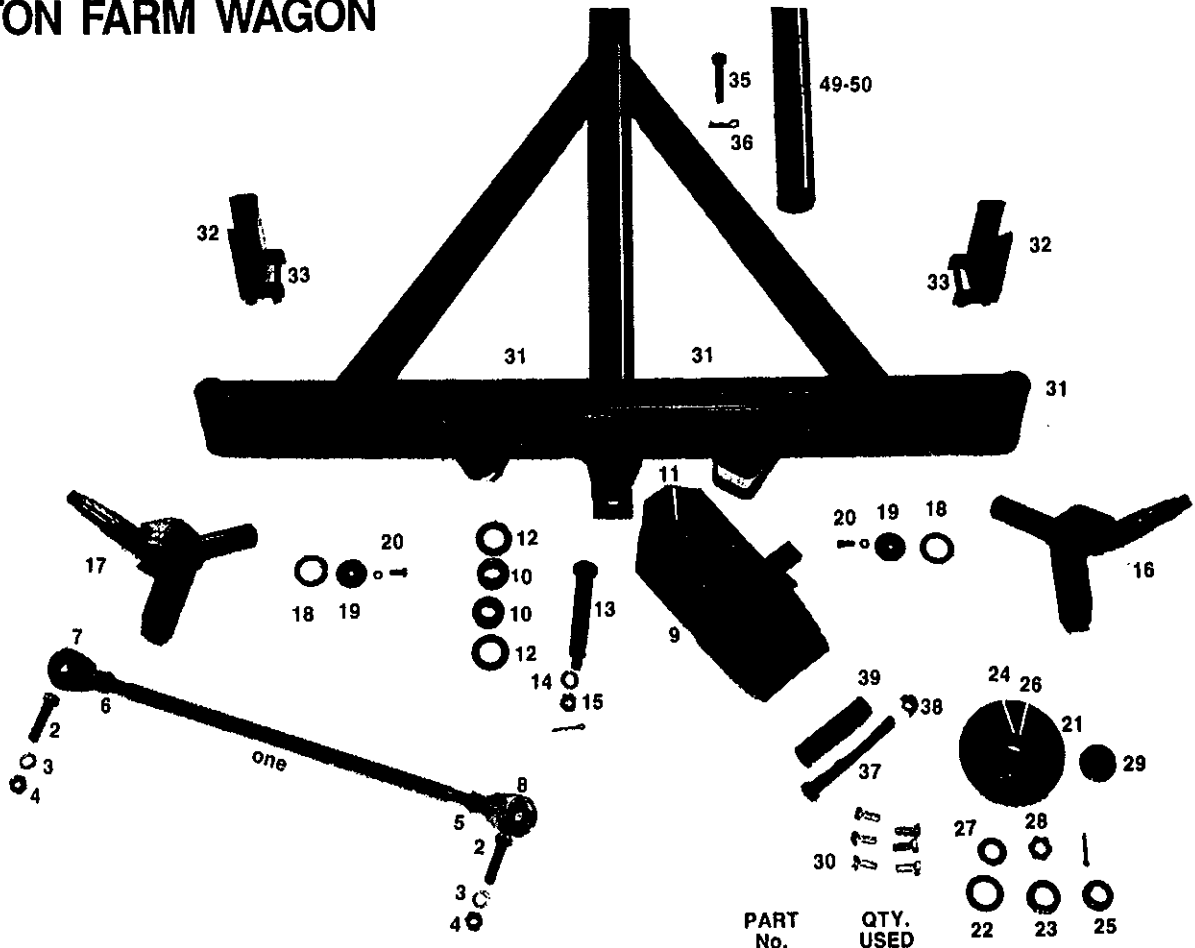

PART No.	QTY. USED	PRICE
1	2	12.00
2	4	1.50
3	4	.15
4	4	.40
5	2	2.00
6	2	1.00
7	2	12.00
8	2	12.00
9	1	56.00
10	2	14.00
11	2	5.00
12	2	5.00
13	1	7.00
14	1	.15
15	1	1.00
16	1	35.00
17	1	35.00
18	2	1.60
19	2	1.00
20	2	.35
21	4	28.00
21A	4	42.00
22	4	4.00
23	4	6.00
24	4	4.50
25	4	5.00
26	4	4.00
27	4	.15
28	4	1.00
29	4	4.00
30	24	.40
31	1	100.00

P-1514

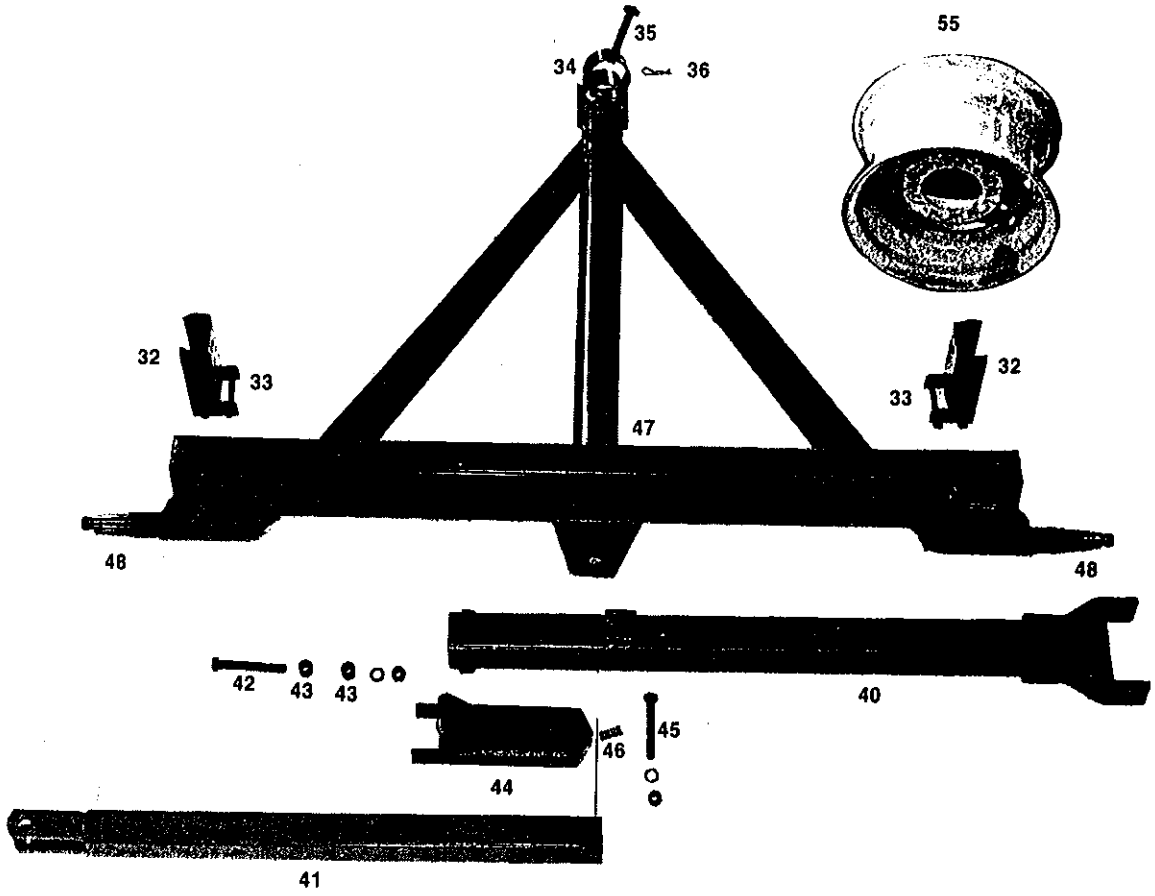

		QTY. USED	PRICE
32	Stake	4	10.00
33	Bolt & Nut 7/16 x 4	8	.60
34	Ring	1	1.50
35	Pin 5/8 x 4	2	1.00
36	Keeper	2	.40
37	7/8 x 8 Bolt	1	3.00
38	7/8 Nut	1	.80
39	Tube 6" long	1	6.50
40	Main Tongue Assembly	1	55.00
41	Tongue Extension	1	30.00
42	5/8 x 4 1/2 Bolt & Nut	1	.75
43	Spacers	2	1.00
44	Latch	1	14.00
45	5/8 x 5 Bolt & Nut	1	.80
46	Spring	1	2.00
47	Rear Axle Assembly	1	125.00
48	Straight Spindle 1 3/4 x 13	2	18.00
49	Reach 6' 7" Std.	1	35.00
50	Reach Optional 10'	1	44.00
52	Wheel 6 x 14 - 6 Bolt		28.00
53	Wheel 8 x 14 - 6 Bolt		32.00
54	Wheel 6 x 15 - 6 Bolt		28.00
55	Wheel 8 x 15 - 6 Bolt		32.00
56	Wheel 6 x 16 - 6 Bolt		32.00
57	Wheel 8 x 16 - 6 Bolt		36.00

Front End Complete	Less Tongue	
	Less Wheels	325.00
Rear End Complete	Less Wheels	205.00
Tongue Complete		90.00

WAGON

MODELE: P-15/4

SERIES: de
à

Réf.	Numéro Pièces	Description	Qté. P-1514
1	10216	Barre de conduite	2
2	Std.	Boulon 3/4" NC 3" lg + écrou et rondelle de blocage	4
5	10217	Écrou de blocage 7/8" NF gauche	2
6	10218	Écrou de blocage 7/8" NF droite	2
7	10219	Rotule filetée à droite	2
8	10220	Rotule filetée à gauche	2
9	10221	Pivot de conduite	1
10	10222	Couronne no. 14123A	2
11	10223	Cuvette no. 14276	2
12	10234	Bague d'étanchéité no CR17488	2
13	10225	Boulon Timken	1
14	Std.	Rondelle plate 13/16"	1
15	10226	Écrou crénelé 3/4"	1
16	10227	Essieux avant droite	1
17	10228	Essieux avant gauche	1
18	10229	Rondelle dure	2
19	10230	Rondelle capuchon	2
20	Std.	Boulon 3/8" NC x 1" lg et rondelle de blocage	2
21	51532	Moyeu no. H-4000	4
21A	51503	Moyeu no. H-4000 assemblé	4
22	51535	Bague d'étanchéité no. CR17415	4
23	51534	Roulement à rouleau Timken : couronne no. LM29749	4
24	51533	Roulement à rouleau Timken : cuvette no. LM29710	4
25	51530	Roulement à rouleau Timken : couronne no. LM67048	4
26	51531	Roulement à rouleau Timken cuvette no. LM67010	4
27	Std.	Rondelle plate 1"	4
28	51529	Écrou crénelé 1" NF x 9/16" épais	4
29	51528	Capuchon D-4000 (2 5/16")	4
30	51418	Vis de jante 9/16"	24
31	10231	Sommier avant	1
32	10232	Épée	4
33	Std.	Boulon 7/16" NC x 4" lg avec écrou	8
34	10235	Bague de la pôle	1
35	10236	Goupille 5/8" x 4" lg	2
36	Std.	Goupille à ressort	2
37	Std.	Boulon 7/8" NC x 8" lg avec écrou	1
39	10237	Tube 6" long	1

Réf.	Numéro Pièces	Description	Qté. P-1514
47	10238	Sommier arrière	1
48	10239	Essieux 1 3/4" x 13"	2
49	10240	Perche 10'	1
55	R-1566	Roue 15" x 6" - 6 trous	4

Model 180

9 TON FARM WAGON

P-1518

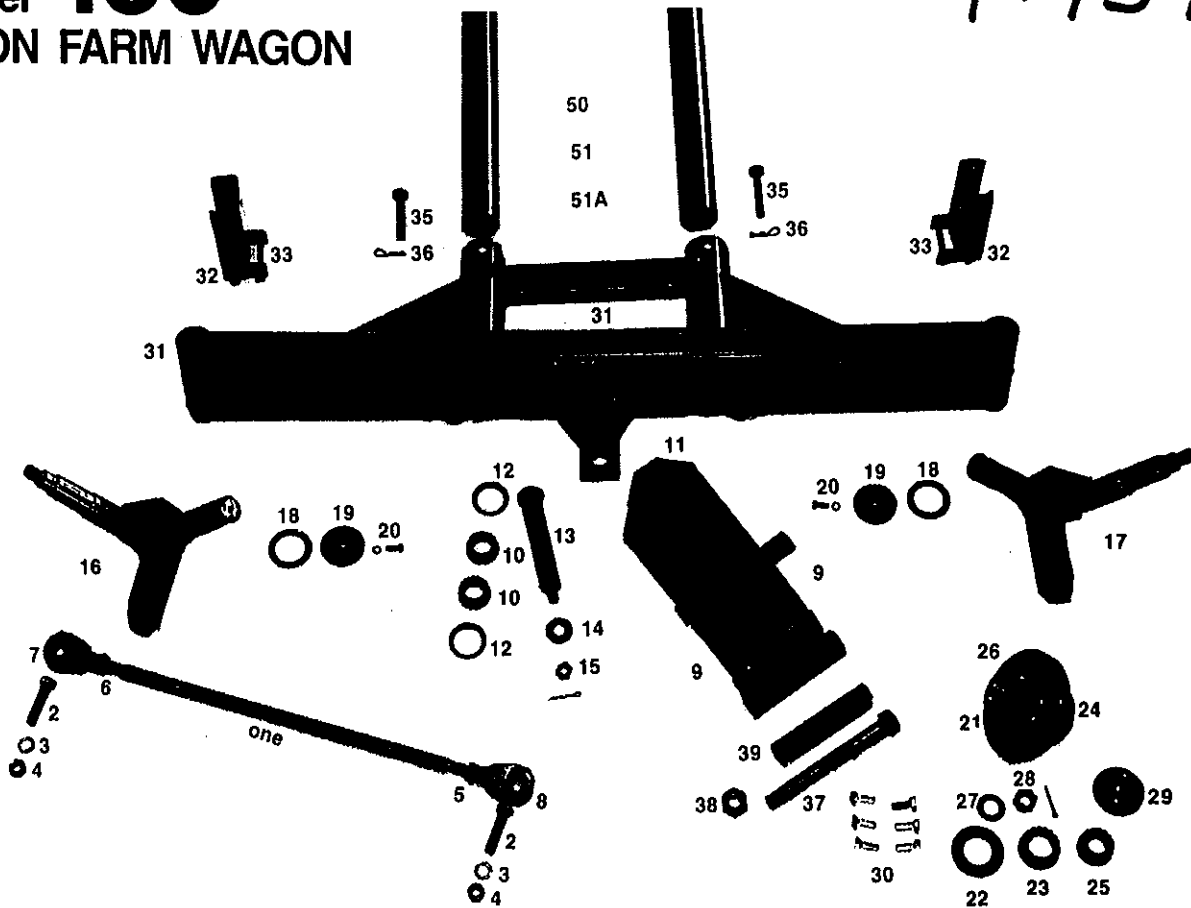

		PART No.	QTY. USED	PRICE
1	Tie Rod	29-5	2	12.00
2	3/4 x 3 Bolt NC		4	1.50
3	3/4 Lock Washer		4	.15
4	3/4 Nut		4	.40
5	7/8 Jam Nut NF LH		2	2.00
6	7/8 Jam Nut NF RH		2	1.00
7	Rod end R Thread		2	12.00
8	Rod end L Thread		2	12.00
9	Tongue Bracket		1	70.00
10	Cone	13686	2	10.00
11	Cup	13620	2	6.00
12	Seal	CR20952	2	4.00
13	Timken bolt		1	8.00
14	13/16 Flat washer		1	.15
15	3/4 Slotted nut		1	1.00
16	Front Right Spindle		1	40.00
17	Front Left Spindle		1	40.00
18	Hardened Washer		2	1.70
19	Retaining Washer		2	1.00
20	3/8 x 1 Bolt & Lockwasher		2	.35
21	Hub	W-6000	4	35.00
21A	Hub Including key 22-30	W-6000	4	48.00
22	Seal	CR20148	4	4.00
23	Inner Cone	25590	4	8.00
24	Inner Cup	25520	4	5.50
25	Outer Cone	25877	4	6.50
26	Outer Cup	25821	4	5.00
27	1" Washer		4	.15
28	1" Slotted hex nuy		4	.50
29	Dust Cap	DC-15	4	4.00
30	Wheel Bolts	9/16 x 1 3/4	24	.40
31	Front Axle assembly		1	120.00

MODEL #180

P-1518

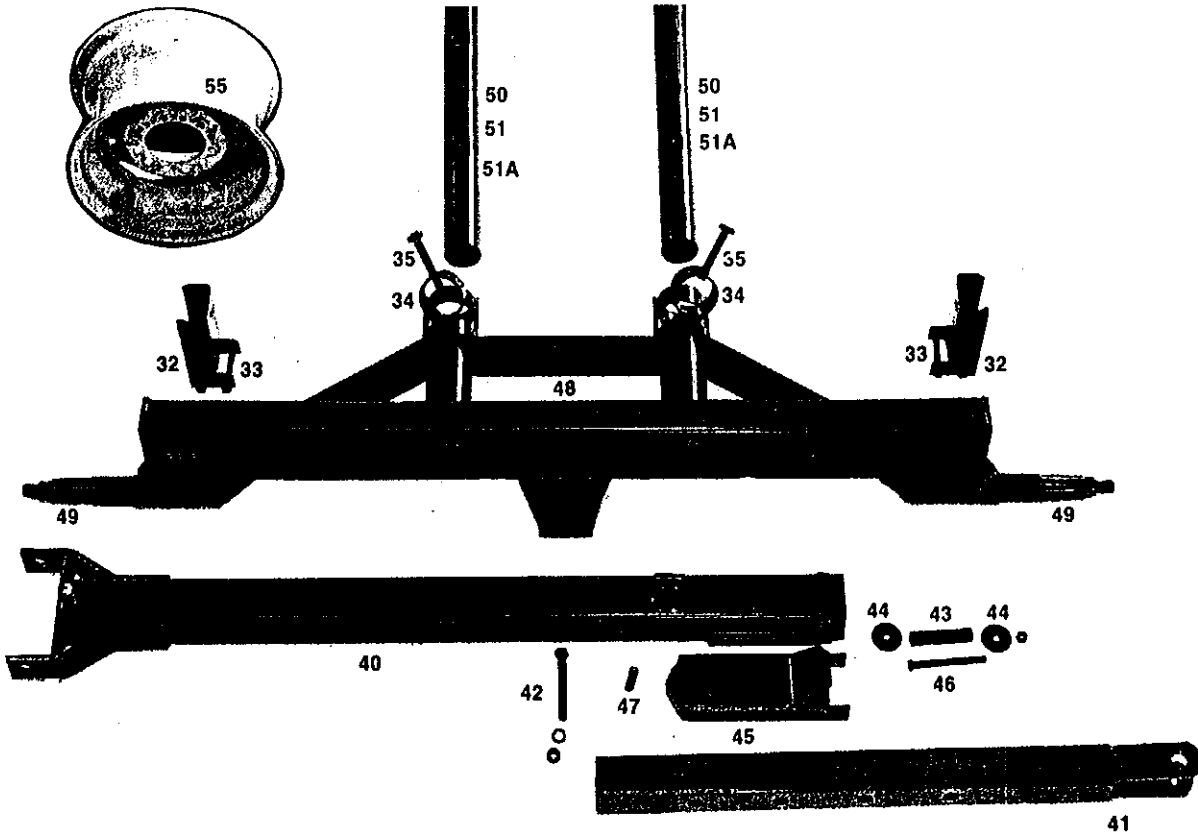

		QTY. USED	PRICE
32	Stake	4	10.00
33	Bolt & Nut 7/16 x 4	8	.60
34	Ring	2	1.50
35	Pin 5/8 x 4	4	1.00
36	Keeper	4	.40
37	1 1/2 x 10 Bolt	1	10.00
38	1 1/2 Nut	1	1.00
39	Tube 8" long	1	7.00
40	Main Tongue Assembly	1	65.00
41	Tongue extension	1	36.00
42	5/8 x 5 Bolt & Nut	1	.80
43	1" x 4 1/2" sleeve	1	3.00
44	Washers	2	.50
45	Latch	1	14.00
46	Bolt & Nut 1/2 x 5 1/2	1	.75
47	Spring	1	2.00
48	Rear Axle Assembly	1	145.00
49	Straight spindle 2 x 15 1/2	2	22.00
50	Reach 11' Std.	2	45.00
51	Reach Optional 14'	2	54.00
51A	Reach Optional 8'	2	36.00
52	Wheel 6 x 14 - 6 Bolt		28.00
53	Wheel 8 x 14 - 6 Bolt		32.00
54	Wheel 6 x 15 - 6 Bolt		28.00
55	Wheel 8 x 15 - 6 Bolt		32.00
56	Wheel 6 x 16 - 6 Bolt		32.00
57	Wheel 8 x 16 - 6 Bolt		36.00
58	Wheel 7 x 20 - 6 Bolt		50.00
	Front End Complete	Less Wheels	
		Less Tongue	365.00
	Rear End Complete	Less Wheels	250.00
	Tongue Complete		105.00

P-1518

Ref.	Parts Number	Description	Qty. P-1518
1	10216	Tie rod	2
2	Std.	Bolt 3/4" NC 3" lg + nut and lockwasher	4
5	10217	Left jam nut 7/8" NF	2
6	10218	Right jam nut 7/8" NF	2
7	10219	Rod end right thread	2
8	10220	Rod end left thread	2
9	10241	Tongue bracket	1
10	10242	Cone no. 13686	2
11	10243	Cup no. 13620	2
12	10244	Seal no CR20952	2
13	10245	Timken bolt	1
14	Std.	Flat washer 13/16"	1
15	10226	Slotted hex nut 3/4"	1
16	10246	Front spindle right	1
17	10247	Front spindle left	1
18	10248	Hardened washer	2
19	10249	Retaining washer	2
20	Std.	Bolt 3/8" NC x 1" lg and lockwasher	2
21	10250	Hub no. H-6000	4
21A	10251	Hub no. H-6000 assembly	4
22	10252	Seal no. CR20148	4
23	10253	Roller bearing Timken : cone no. 25590	4
24	10254	Roller bearing Timken : cup no. 25520	4
25	10255	Roller bearing Timken : cone no. 25877	4
26	10256	Roller bearing Timken cup no. 25821	4
27	Std.	Flat washer 1"	4
28	10257 10252 ⁹	Slotted hex nut 1" NF x 9/16"	4
29	10258	Dust cap DC-15	4
30	51418	Wheels bolts 9/16" x 1 3/4"	24
31	10259	Front axle assembly	1
32	10232	Stake	4
33	Std.	Bolt 7/16" NC x 4" lg with nut	8
34	10235	Ring	1
35	10236	Pin 5/8" x 4" lg	2
36	Std.	Spring pin	2
37	Std.	Bolt 1 1/8" NC x 10" lg with nut	1
39	10260	Tube 8" long	1

Ref.	Parts Number	Description	Qty. P-1518
48	10261	Rear axle assembly	1
49	10262	Straight spindle 2" x 15 1/2"	2
50	10263 10257	Reach 11'	1
55	R-1586	Wheel 15" x 8" - 6 bolts	4
40 10275 timon ext.			

Model 200

10 TON FARM WAGON

200H = P-1520
200W = P-1522

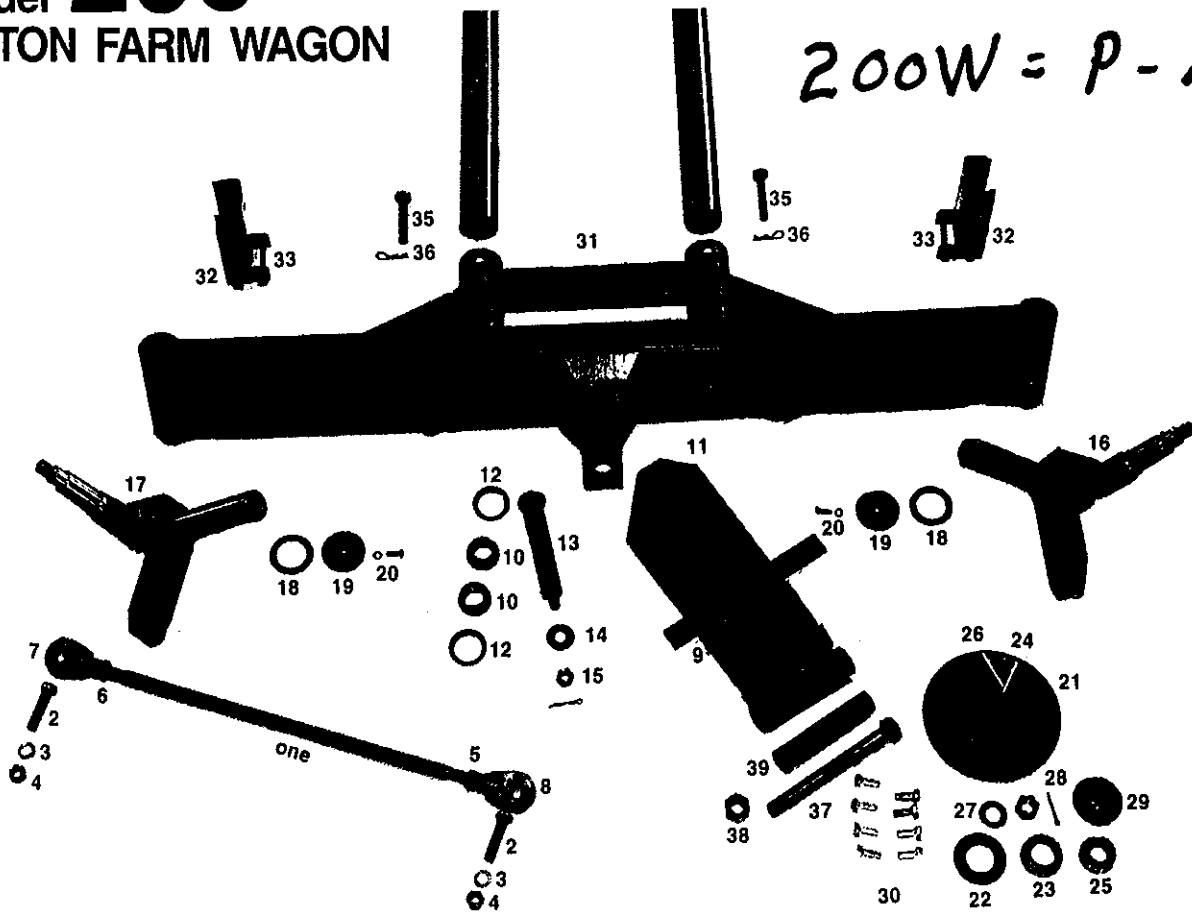

		PART No.	QTY. USED	PRICE
1**	Tie Rod 31-0	28-5	2	12.00
2	3/4 x 3 Bolt NC		4	1.50
3	3/4 Lockwasher		4	.15
4	3/4 Nut		4	.40
5	7/8 Jam Nut NF LH		2	2.00
6	7/8 Jam Nut NF RH		2	1.00
7	Rod End R Thread		2	12.00
8	Rod End L Thread		2	12.00
9	Tongue Bracket		1	72.00
10	Cone	13686	2	10.00
11	Cup	13620	2	6.00
12	Seal	CR20952	2	4.00
13	Timken Bolt		1	8.00
14	13/16 Flatwasher		1	.15
15	3/4 Slotted Hex Nut		1	1.00
16**	Front Right Spindle		1	52.00
17**	Front Left Spindle		1	52.00
18	Hardened Washer	2-25	2	2.00
19	Retaining Washer		2	1.00
20	3/8 x 1 Bolt & Lockwasher		2	.35
21	Hub	H-811	4	42.00
21A	Hub including key 22-30	H-811	4	58.00
22	Seal	CR20148	4	4.00
23	Inner Cone	25590	4	8.00
24	Inner Cup	25520	4	5.50
25	Outer Cone	25877	4	6.50
26	Outer Cup	25821	4	5.00
27	1" Washer		4	.15
28	1" Slotted hex nut		4	.50
29	Dust Cap	DC-17	4	4.00
30	Wheel Bolts		32	.40
31**	Front Axle Assembly			150.00

MODEL #200

200H = P-1520
200W = P-1522

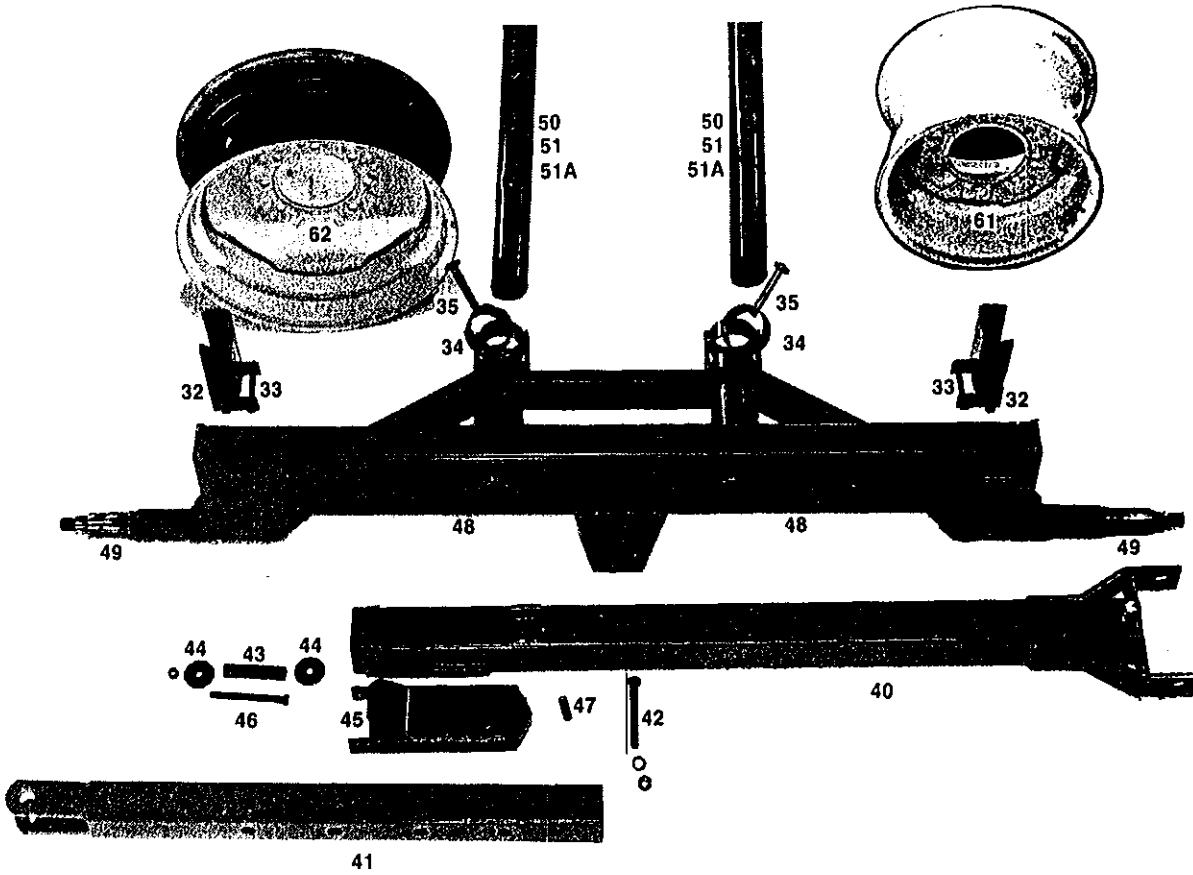

		QTY. USED	PRICE
32	Stake	4	10.00
33	Bolt & Nut 7/16 x 4	8	.60
34	Ring	2	1.50
35	Pin 5/8 x 4	4	1.00
36	Keeper	4	.40
37	1 1/2 x 10 Bolt	1	10.00
38	1 1/2 Nut	1	1.00
39	Tube 8" long	1	7.00
40	Main Tongue Assembly	1	65.00
41	Tongue Extension	1	36.00
42	5/8 x 5 Bolt & Nut	1	.80
43	1" x 4 1/2 long sleeve	1	3.00
44	Washers	2	.50
45	Latch	1	14.00
46	Bolt & Nut 5/2 x 1/2	1	.75
47	Spring	1	2.00
48**	Rear Axle Assembly	1	160.00
49**	Straight spindle	2 1/4 x 15 1/2	36.00
50	Reach 11' Std.	2	45.00
51	Reach Optional 14'	2	54.00
51A	Reach Optional 8'	2	36.00
60	Wheel 10 x 15 - 8 Bolt		40.00
61	Wheel 10 x 16 - 8 Bolt		42.00
62	Wheel 8 x 20 - 8 Bolt		58.00
65	Wheel 8 x 20 Split Rim		85.00

**When ordering specify whether 200H or 200W

Front End Complete	Less Wheels	430.00	→ 4695.00 detail
	Less Tongue		
Rear End Complete	Less Wheels	290.00	
Tongue Complete		105.00	

Réf.	Numéro		Qté.	
	Pièces	Description	P-1520	P-1522
1	10264	Barre de conduite	2	-
1	10265	Barre de conduite	-	2
2	std.	Boulon 3/4" NC 3" lg + écrou et rondelle de blocage	4	4
5	10217	Écrou de blocage 7/8" NF gauche	2	2
6	10218	Écrou de blocage 7/8" NF droite	2	2
7	10219	Rotule filetée à droite	2	2
8	10220	Rotule filetée à gauche	2	2
9	10266	Pivot de conduite	1	1
10	10242	Couronne no. 13686	2	2
11	10243	Cuvette no. 13620	2	2
12	10244	Bague d'étanchéité no CR20952	2	2
13	10245	Boulon Timken	1	1
14	Std.	Rondelle plate 13/16"	1	1
15	10226	Écrou crénelé 3/4"	1	1
16	10267	Essieux avant droite	1	-
16	10268	Essieux avant droite	-	1
17	10269	Essieux avant gauche	1	-
17	10270	Essieux avant gauche	-	1
18	10271	Rondelle <i>deux</i>	2	2
19	10272	Rondelle capuchon	2	2
20	Std.	Boulon 3/8" NC x 1" lg et rondelle de blocage	2	2
21	10273	Moyeu no. H-811	4	4
21A	10274	Moyeu no. H-811 assemblé	4	4
22	10252	Bague d'étanchéité no. CR20148	4	4
23		Roulement à rouleau Timken : couronne no. 25590	4	4
24		Roulement à rouleau Timken : cuvette no. 25520	4	4
25		Roulement à rouleau Timken : couronne no. 25877	4	4
26		Roulement à rouleau Timken cuvette no. 25821	4	4
27	Std.	Rondelle plate 1"	4	4
28		Écrou crénelé 1" NF x 9/16" épais	4	4
29		Capuchon DC-17	4	4
30	51418	Vis de jante 9/16"	32	32
31		Sommier avant	1	-
31		Sommier avant	-	1
32		Épée	4	4
33		Boulon 7/16" NC x 4" lg avec écrou	8	8
34		Bague de la pôle	2	2
35		Goupille 5/8" x 4" lg	4	4
36	Std.	Goupille à ressort	4	4
37	Std.	Boulon 1 1/8" NC x 10" lg avec écrou	1	1
39		Tube 8" long	1	1

Réf.	Numéro		Qté.	
	Pièces	Description	P-1520	P-1522
48		Sommier arrière	1	-
48		Sommeir arrière	-	1
49		Essieux 2 1/4"	1	-
49		Essieux 2 1/4"	-	1
50		Perche 11"	2	2
61		Roue 15" x 10" - 8 trous	-	4
62		Roue 20" x 8" - 8 trous	4	-

Model ~~188~~ 240
 9 TON FARM WAGON

P-1524

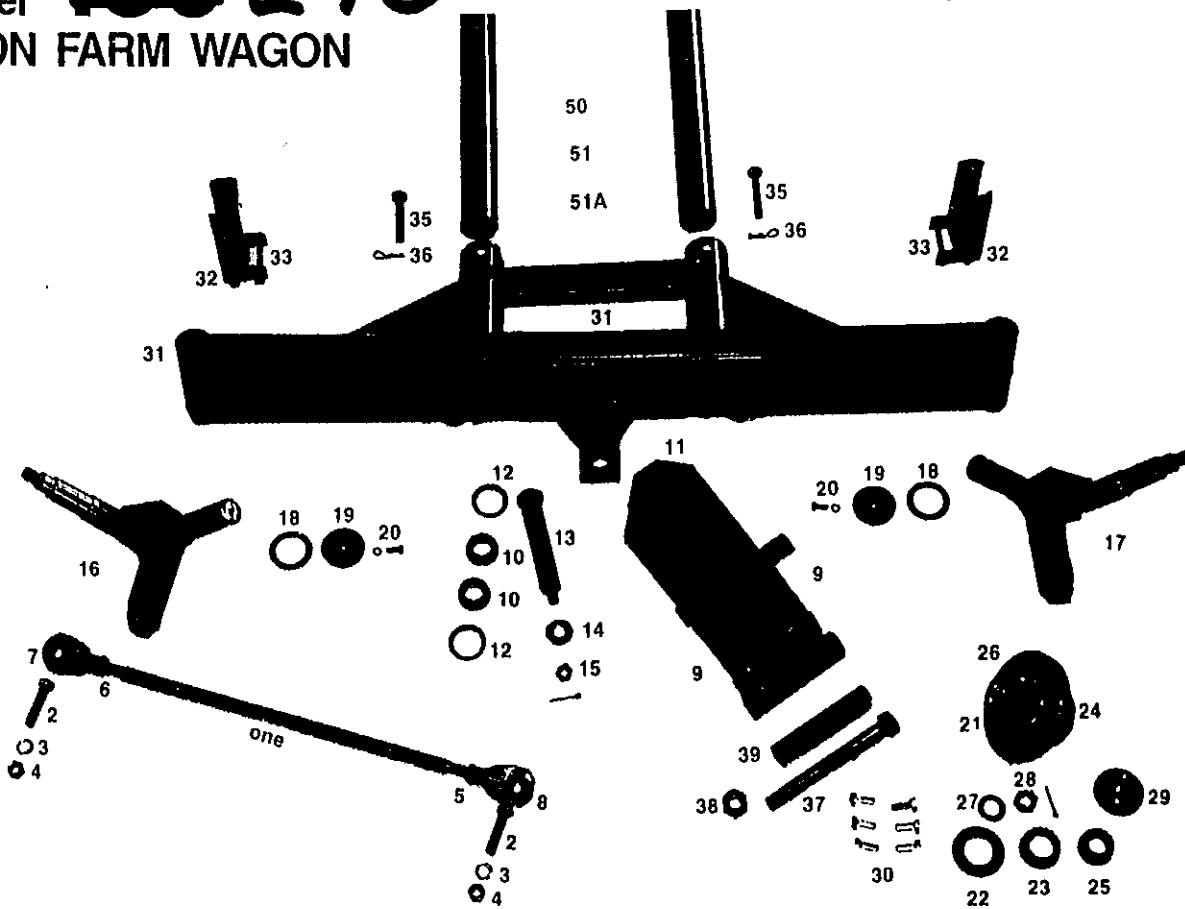

PART No.	DESCRIPTION	PART No.	QTY. USED	PRICE
1	Tie Rod	29-5	2	12.00
2	3/4 x 3 Bolt NC		4	1.50
3	3/4 Lock Washer		4	.15
4	3/4 Nut		4	.40
5	7/8 Jam Nut NF LH		2	2.00
6	7/8 Jam Nut NF RH		2	1.00
7	Rod end R Thread		2	12.00
8	Rod end L Thread		2	12.00
9	Tongue Bracket		1	70.00
10	Cone	13686	2	10.00
11	Cup	13620	2	6.00
12	Seal	CR20952	2	4.00
13	Timken bolt		1	8.00
14	13/16 Flat washer		1	.15
15	3/4 Slotted nut		1	1.00
16	Front Right Spindle		1	40.00
17	Front Left Spindle		1	40.00
18	Hardened Washer		2	1.70
19	Retaining Washer		2	1.00
20	3/8 x 1 Bolt & Lockwasher		2	.35
21	Hub	W-6000	4	35.00
21A	Hub Including key 22-30	W-6000	4	48.00
22	Seal	CR20148	4	4.00
23	Inner Cone	25590	4	8.00
24	Inner Cup	25520	4	5.50
25	Outer Cone	25877	4	6.50
26	Outer Cup	25821	4	5.00
27	1" Washer		4	.15
28	1" Slotted hex nuy		4	.50
29	Dust Cap	DC-15	4	4.00
30	Wheel Bolts	9/16 x 1 3/4	24	.40
31	Front Axle assembly		1	120.00

Models **240** ~~██████████~~ 12 ~~██████~~ TON TANDEM

P-1524

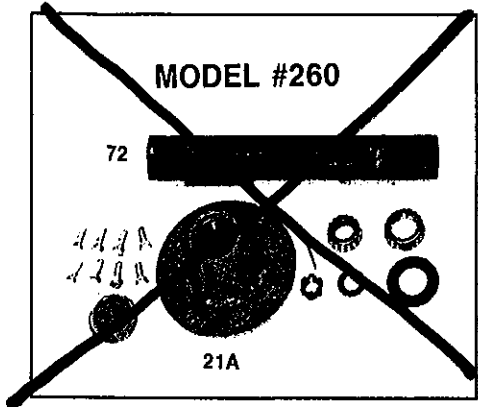

MODEL #240

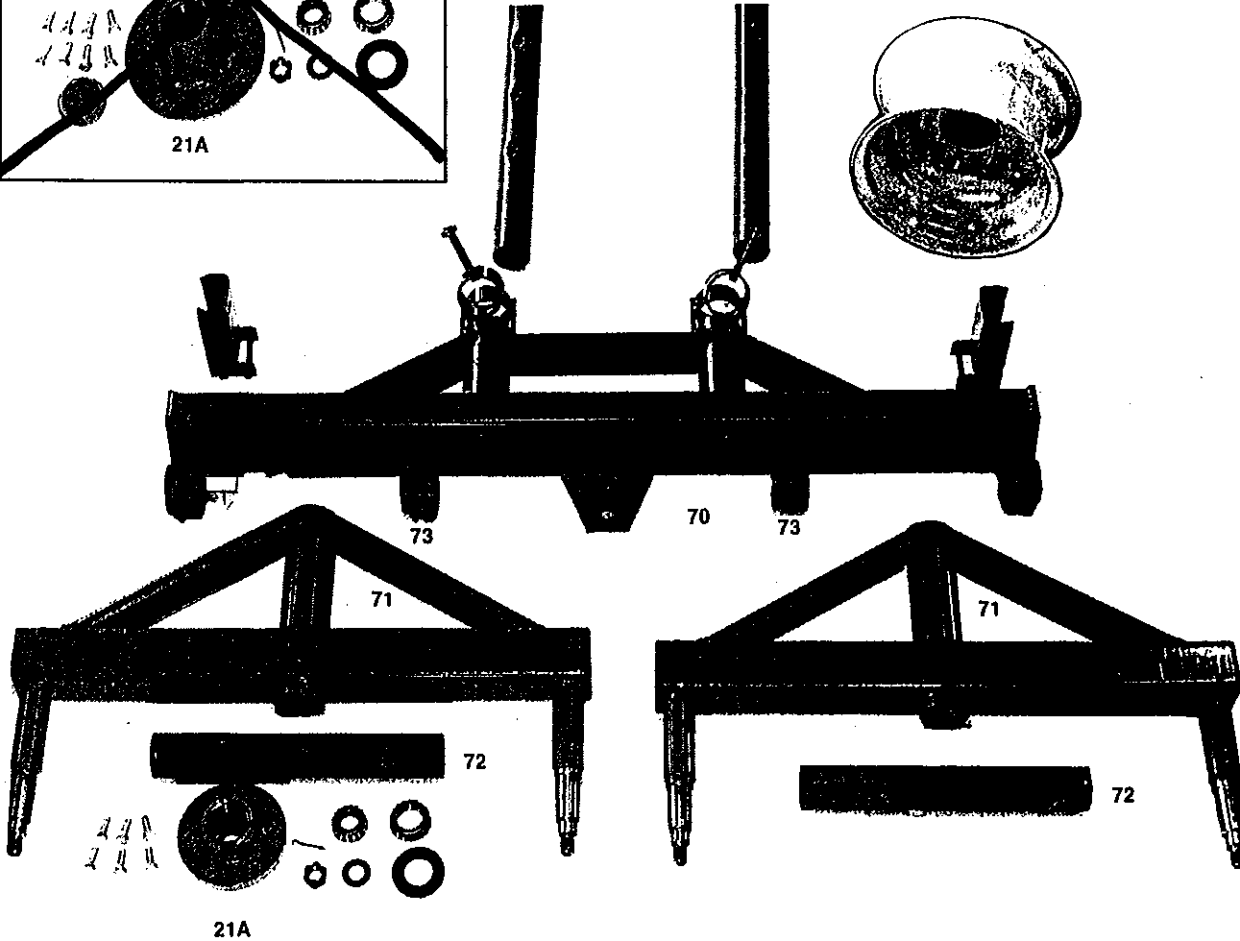

MODEL 240

For Tongue, Front end, Reaches, Hubs & Stakes use Model 180 Parts List

70	Rear Axle Assembly 3 x 6 Box Beam	1	145.00
71	Walking Beam	2	130.00
72	3" O.D. Tube 20" long	2	10.00
73	1/2 x 4 Bolt & Nut	2	.70
21A	Hub c/w parts	W-6000 4	48.00

240	Rear End Complete	Less Wheels	580.00
240	Walking Beam c/w Hubs	Less Wheels	215.00

~~**MODEL 260**~~

~~For Tongue, Front end, Reaches, Hubs & Stakes use Model 260 Parts List~~

70	Rear Axle Assembly 3 x 7 Box Beam	1	162.00
71	Walking Beam	2	130.00
72	3" O.D. Tube 20" long	2	10.00
73	1/2 x 4 Bolt & Nut	2	.70
21A	Hub c/w parts	H-81 4	58.00

260	Rear End Complete	Less Wheels	625.00
260	Walking Beam c/w Hubs	Less Wheels	235.00

Model ~~260~~ **260**
 10 TON FARM WAGON

P-1526

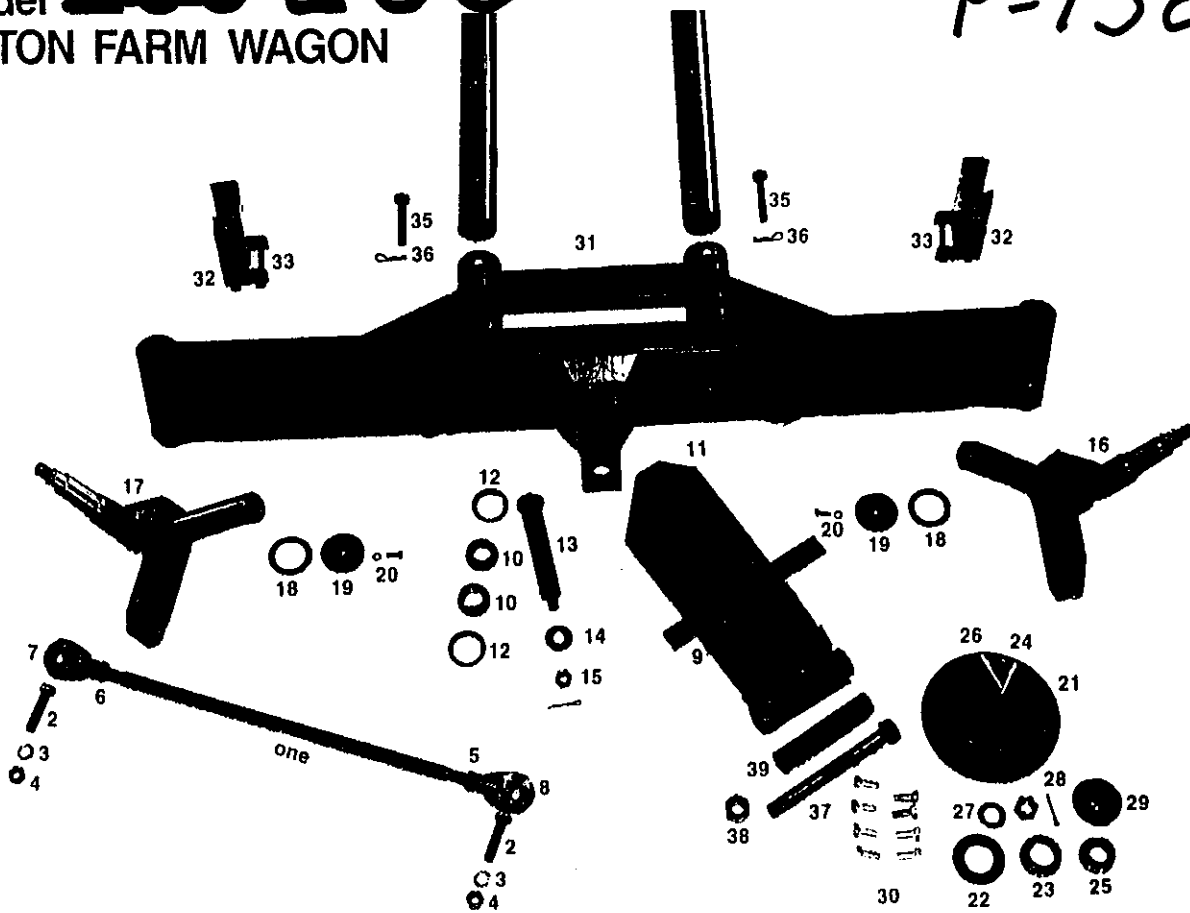

PART No.	DESCRIPTION	QTY. USED	PRICE
1**	Tie Rod 31-0	28-5	2 12.00
2	3/4 x 3 Bolt NC		4 1.50
3	3/4 Lockwasher		4 .15
4	3/4 Nut		4 .40
5	7/8 Jam Nut NF LH		2 2.00
6	7/8 Jam Nut NF RH		2 1.00
7	Rod End R Thread		2 12.00
8	Rod End L Thread		2 12.00
9	Tongue Bracket		1 72.00
10	Cone	13686	2 10.00
11	Cup	13620	2 6.00
12	Seal	CR20952	2 4.00
13	Timken Bolt		1 8.00
14	13/16 Flatwasher		1 .15
15	3/4 Slotted Hex Nut		1 1.00
16**	Front Right Spindle		1 52.00
17**	Front Left Spindle		1 52.00
18	Hardened Washer	2-25	2 2.00
19	Retaining Washer		2 1.00
20	3/8 x 1 Bolt & Lockwasher		2 .35
21	Hub	H-811	4 42.00
21A	Hub Including key 22-30	H-811	4 58.00
22	Seal	CR20148	4 4.00
23	Inner Cone	25590	4 8.00
24	Inner Cup	25520	4 5.50
25	Outer Cone	25877	4 6.50
26	Outer Cup	25821	4 5.00
27	1" Washer		4 .15
28	1" Slotted hex nut		4 .50
29	Dust Cap	DC-17	4 4.00
30	Wheel Bolts		32 .40
31**	Front Axle Assembly		150.00

Models ~~240~~ & 260 12 & 13 TON TANDEMS

P-1526

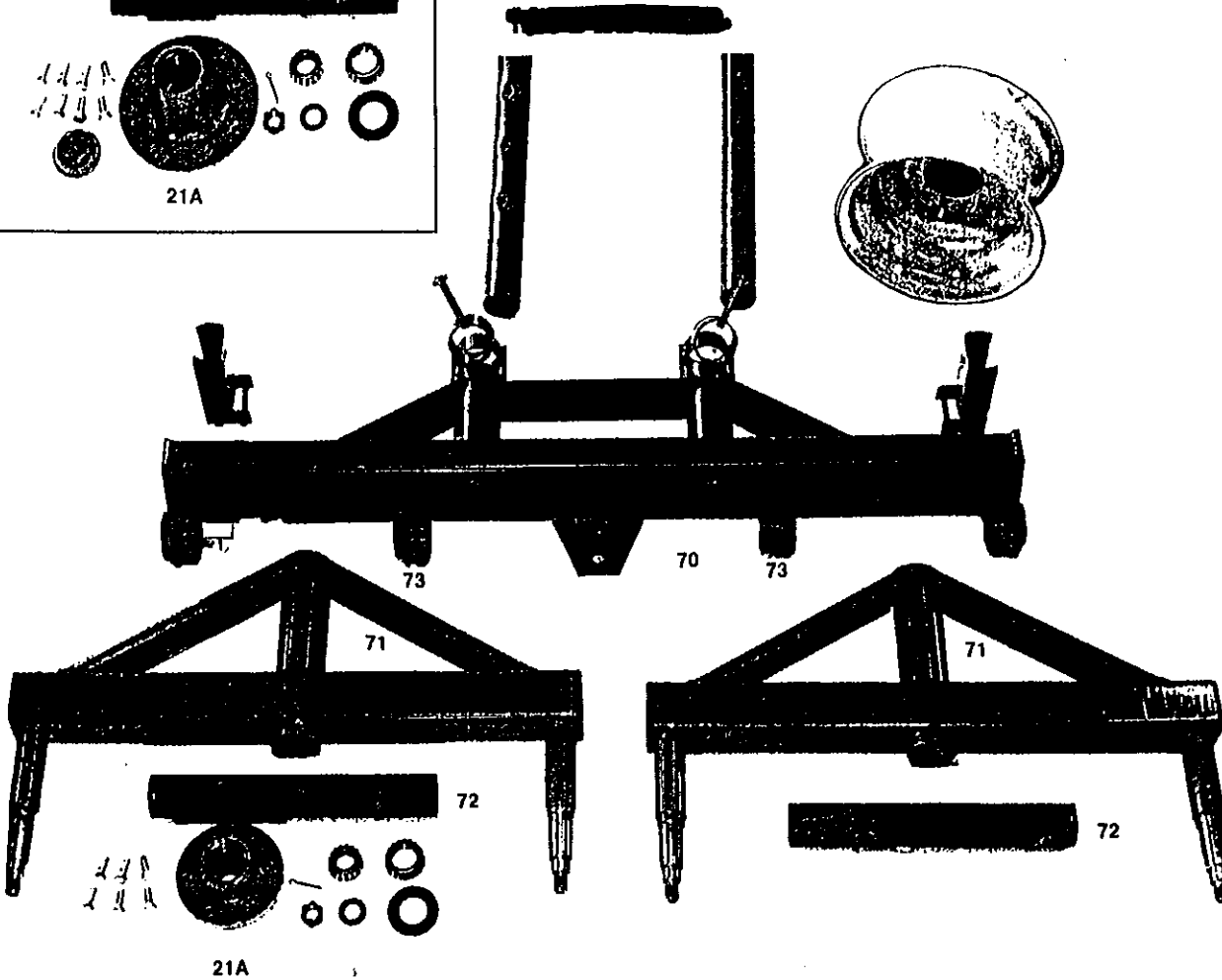
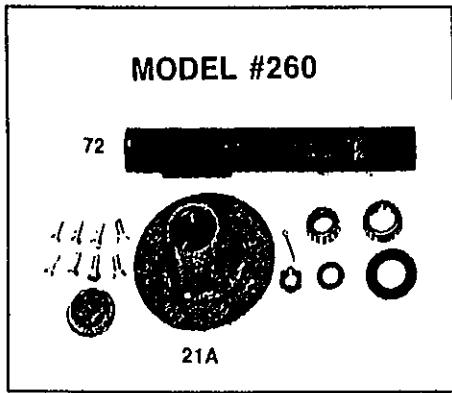

MODEL 240

For Tongue, Front end, Reaches, Hubs & Stakes use Model 180 Parts List

70	Rear Axle Assembly 3 x 6 Box Beam	1	149.00
71	Walking Beam	2	130.00
72	3" O.D. Tube 20" long	2	10.00
73	1/2 x 4 Bolt & Nut	2	.70
21A	Hub c/w parts	4	48.00

240	Rear End Complete	Less Wheels	580.00
240	Walking Beam c/w Hubs	Less Wheels	215.00

MODEL 260

For Tongue, Front end, Reaches, Hubs & Stakes use Model 200 Parts List

70	Rear Axle Assembly 3 x 7 Box Beam	1	152.00
71	Walking Beam	2	130.00
72	3" O.D. Tube 20" long	2	10.00
73	1/2 x 4 Bolt & Nut	2	.70
21A	Hub c/w parts	H-811 4	58.00

260	Rear End Complete	Less Wheels	625.00
260	Walking Beam c/w Hubs	Less Wheels	235.00

Model 280

14 TON FARM WAGON

P-1528

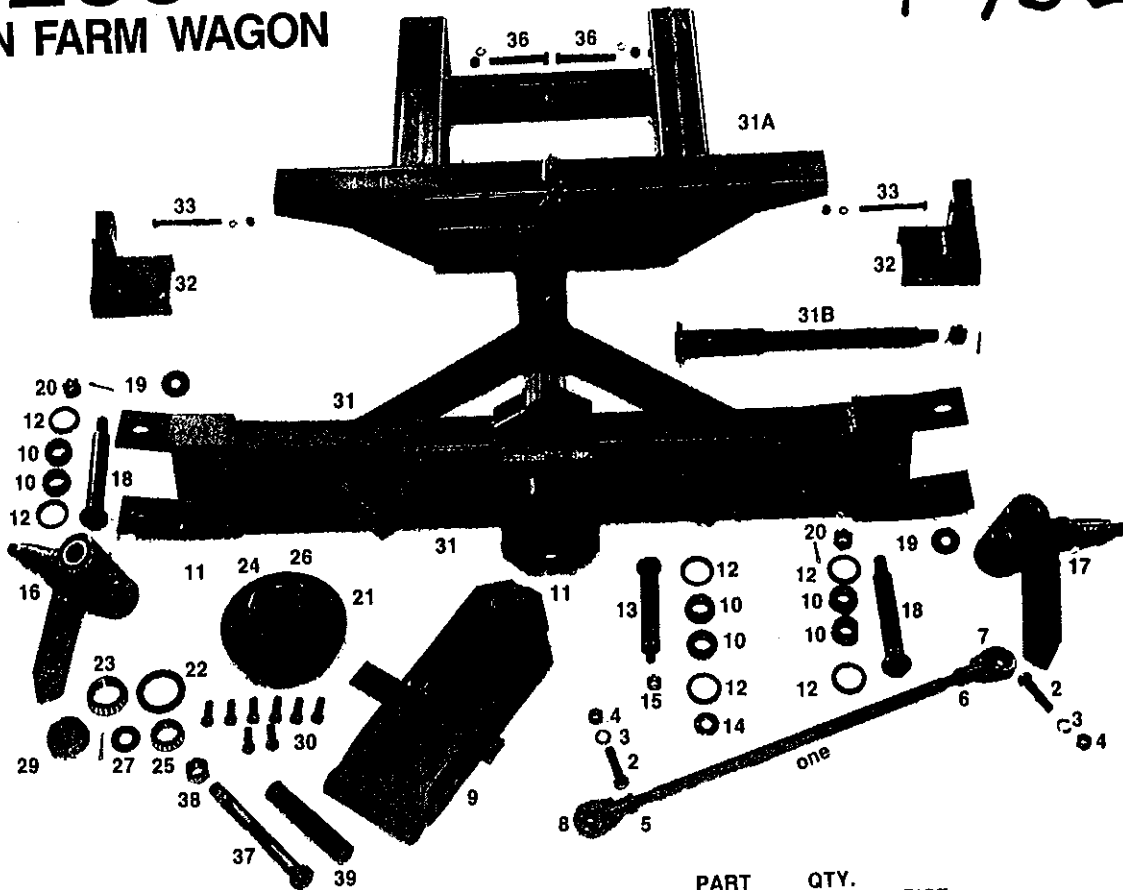

		PART No.	QTY. USED	PRICE	
	1	Tie Rod	31-5	2	12.00
	2	3/4 x 3 Bolt NC		4	1.50
	3	3/4 Lockwasher		4	.15
	4	3/4 Nut		4	.40
	5	7/8 Jam Nut NF LH		2	2.00
	6	7/8 Jam Nut NF RH		2	1.00
	7	Rod End R Thread		2	12.00
	8	Rod End L Thread		2	12.00
	9	Tongue Bracket		1	86.00
	10	Cone	13686	2	10.00
	11	Cup	13620	2	6.00
	12	Seal	CR20952	2	4.00
	13	Timken Bolt		1	8.00
	14	13/16 Flatwasher		1	.15
	15	3/4 Slotted Nut		1	1.00
	16	Front Right Spindle		1	75.00
	17	Front Left Spindle		1	75.00
	18	King Pin		2	10.00
	19	1" Flatwasher		2	.15
	20	1" Slotted Nut		2	1.00
	21	Hub	8000	4	54.00
	21A	Hub Including Key 22-30	8000	4	75.00
	22	Seal	CR27361	4	4.00
	23	Inner Cone	JLM506849	4	9.00
	24	Inner Cup	JLM506810	4	4.00
	25	Outer Cone	LM5011349	4	5.00
	26	Outer Cup	LM501310	4	3.50
	27	1" Washer	EM1-8000	4	.25
	28	1" Slotted Hex Nut	SF-114	4	1.00
	29	Dust Cap	D-8000	4	4.00
	30	Wheel Bolts	5/8 x 2	8	.75
	31	Front Axle Assembly		1	200.00
	31A	Front Bolster Assembly		1	160.00
	31B	Front Bolster Pin		1	20.00

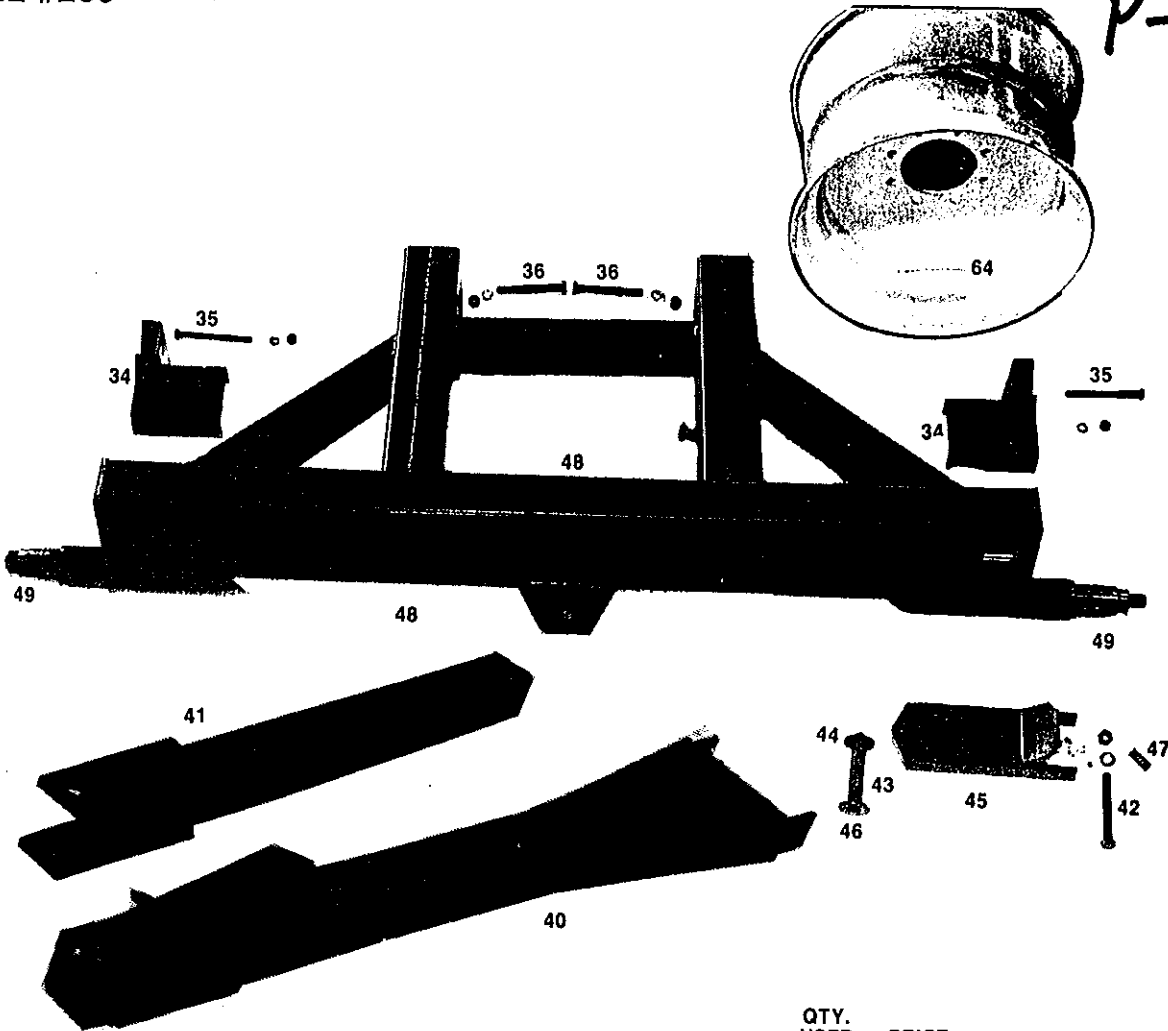

		QTY. USED	PRICE
32	Stake Front	2	14.00
33	Bolt 1/2 x 6	2	.75
34	Stake Rear	2	14.00
35	Bolt 1/2 x 5 1/2	2	.75
36	Bolt 5/8 x 5 1/2	4	.90
37	1 1/8 x 10 Bolt	1	10.00
38	1 1/8 Nut	1	1.00
39	Tube 8" long	1	7.00
40	Main Tongue Assembly	1	80.00
41	Tongue Extension	1	40.00
42	5/8 x 5 Bolt & Nut	1	.80
43	1" x 4 1/2 long sleeve	1	3.00
44	Washers	2	.50
45	Latch	1	14.00
46	Bolt 1/2 x 5 1/2	1	.75
47	Spring	1	2.00
48	Rear Axle Assembly		230.00
49	Straight spindle 2 3/4 x 18	2	40.00
50	Reach 10' Std.	2	75.00
51	Reach 12' Optional	2	87.00
51A	Reach 10' Optional	2	63.00
60	Wheel 10 x 15 - 8 bolt		40.00
61	Wheel 10 x 16 - 8 bolt		42.00
62	Wheel 8 x 20 - 8 bolt		58.00
63	Wheel WC-11 x 16.1		58.00
64	Wheel 13 x 22 1/2		170.00
65	Wheel 8 x 20 Split Rim		85.00
	Front End Complete	Less Wheels	
		Less Tongue	850.00
	Rear End Complete	Less Wheels	400.00
	Tongue Complete		130.00

MODEL 285

15 TON FARM WAGON

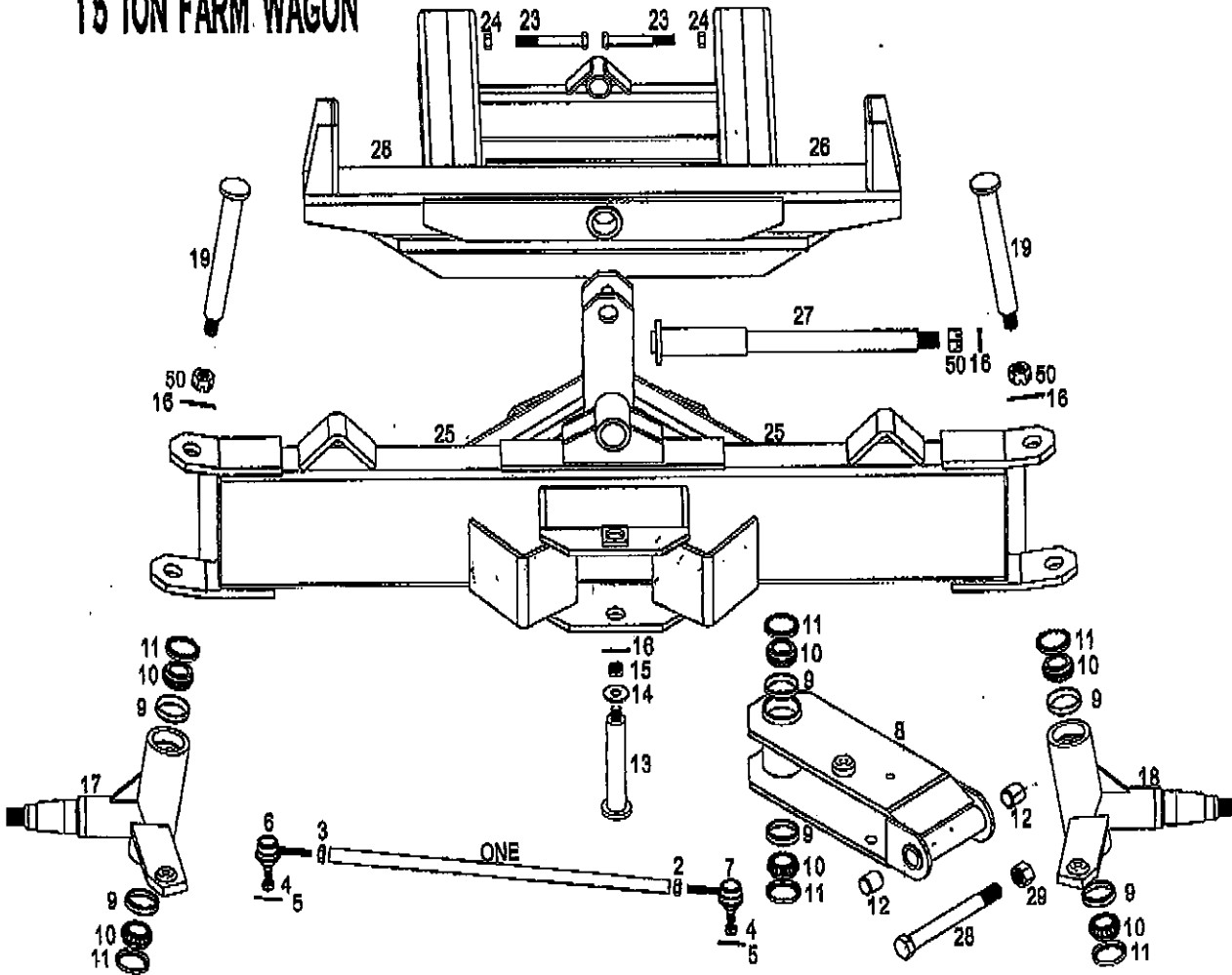

REF. NO.	PART NO.	DESCRIPTION	QTY. USED
1	22-1098	Tie Rod (34)	2
2	11-1089	1" Jam Nut NF 1-16 LH	2
3	11-1100	1" Jam Nut NF 1-16 RH	2
4	11-1101	5/8 NF Slotted Hex Nut	4
5	11-1102	3/16 x 1-1/2 Cotter Pin	4
6	11-1103	Rod End R Thread	2
7	11-1104	Rod End L Thread	2
8	22-1105	Tongue Bracket	1
9	11-1009	Cup (13620)	6
10	11-1010	Cone (13686)	6
11	11-1011	Seal (CR20952)	6
12	11-1054	Bushing (1-3/8 x 1-1/8 x 1-1/2)	2
13	22-1106	Timken Bolt	1
14	11-1014	13/16 Flat Washer	1
15	11-1015	3/4 Slotted Hex Nut	1
16	11-1016	3/16 x 2 Cotter Pin	6
17	11-1107	Front Right Spindle	1
18	11-1108	Front Left Spindle	1
19	22-1109	King Pin	2
20	22-1112	Reach 10' Standard	2
21	22-1113	Reach 12' Optional	2
22	22-1114	Reach 8' Optional	2
23	11-1115	5/8 x 5-1/2 Bolt	4
24	11-1026	5/8 Lock Nut	4
25	22-1116	Front Axle Assembly	1
26	22-1117	Front Bolster Assembly	1
27	22-1118	Front Bolster Pin	1

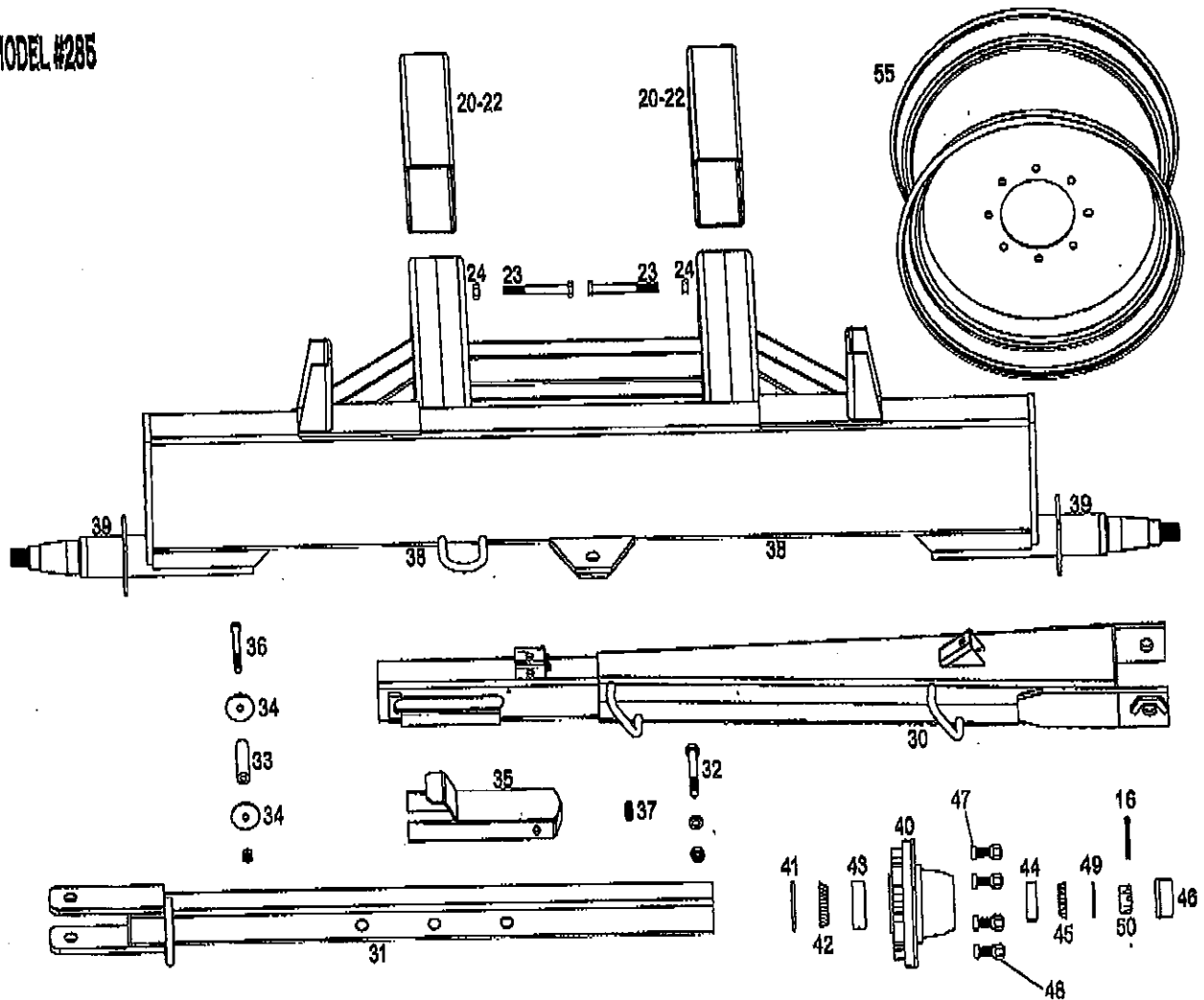

REF. NO.	PART NO.	DESCRIPTION	QTY. USED
28	11-1285	1-1/8 x 10-5/8 Bolt Gr. 5	1
29	11-1080	1-1/8 Lock Nut	1
30	22-1111	Main Tongue Assembly	1
31	22-1119	Tongue Extension	1
32	11-1084	5/8 x 5-1/2 Bolt & Nut	1
33	22-1086	1 x 4-1/2 Sleeve	2
34	22-1085	Washer	1
35	22-1087	Latch	1
36	11-1088	1/2 x 5-1/2 Bolt & Nut	1
37	11-1037	Spring	1
38	22-1120	Rear Axle Assembly	1
39	11-1121	Straight Spindle (2-3/4 x 18)	2
40	11-1122	Hub (8000) c/w Press In Bolts	4
40A	33-1123	Hub Including Key 40-48 (8000)	4
41	11-1124	Seal (CR27361)	4
42	11-1125	Inner Cone (JLM506849)	4
43	11-1126	Inner Cup (JLM506810)	4
44	11-1127	Outer Cup (LM501310)	4
45	11-1128	Outer Cone (LM501349)	4
46	11-1129	Dust Cap (D-8000)	4
47	11-1130	Press In Bolts (5/8 x 2-1/8)	32
48	11-1131	Wheel Nuts (68 CONE)	32
49	11-1132	1" Washer (EM-8000) Heavy Duty	4
50	11-1081	1" Slotted Hex Nut (1-14)	7
51	WH-15108	Wheel 15 x 10 - 8 Bolt	4
52	WH-16108	Wheel 16 x 10 - 8 Bolt	4
53	WH-2088	Wheel 20 x 8 - 8 Bolt	4
54	WH-141618	Wheel W14C x 16.1 - 8 Bolt	4
55	WH-2251358	Wheel 22.5 x 18.5 - 8 Bolt	4
56	WH-161618	Wheel W16C x 16.1 - 8 Bolt	4
57	WH-2258258	Wheel 22.5 x 8.25 - 8 Bolt	4
	33-1134	Front End Complete (Less Tongue & Wheels)	1
	33-1135	Rear End Complete (Less Wheels)	1
	33-1136	Tongue Complete	1