

**Alberta  
Ag-Industries Ltd.**

**OPERATOR'S / PARTS  
MANUAL**

**Agripac<sup>®</sup>  
Lastic Tuber<sup>™</sup>**

**Models  
9000 & 9100**

Copyright © Alberta Ag-Industries Ltd., 2000

All rights reserved.  
Printed in Canada.

---



---

# TABLE OF CONTENTS

---

| Section   | Item  | Page      |
|-----------|---|-----------|
| <b>1</b>  | <b>Introduction .....</b>                                 | <b>5</b>  |
| <b>2</b>  | <b>Safety .....</b>                                       | <b>6</b>  |
|           | General Safety .....                                      | 6         |
|           | Safety in Operation .....                                 | 6         |
|           | Safety with Maintenance .....                             | 7         |
|           | Safety in Transport .....                                 | 7         |
|           | Safety in Storage .....                                   | 7         |
| <b>3</b>  | <b>Decals .....</b>                                       | <b>8</b>  |
|           | Safety Decals .....                                       | 8         |
|           | Maintenance Decals .....                                  | 9         |
| <b>4</b>  | <b>Start-up .....</b>                                     | <b>10</b> |
|           | Basic Start-up Procedures .....                           | 10        |
|           | Ground Preparation .....                                  | 11        |
|           | Adjustments of AgriPac® Lastic Tuber™ .....               | 11        |
|           | Installation of Tube .....                                | 13        |
|           | Operation .....   | 15        |
| <b>5</b>  | <b>Maintenance .....</b>                                  | <b>17</b> |
| <b>6</b>  | <b>Storage .....</b>                                      | <b>18</b> |
| <b>7</b>  | <b>Specifications .....</b>                               | <b>19</b> |
| <b>8</b>  | <b>Parts List .....</b>                                   | <b>20</b> |
|           | AgriPac® Lastic Tuber™ 9000 Assembly .....                | 20        |
|           | AgriPac® Lastic Tuber™ 9100 Assembly .....                | 23        |
|           | Detail of Arch Model 9000 .....                           | 26        |
|           | Detail of Arch Model 9100 .....                           | 27        |
|           | Automatic System Detail .....                             | 28        |
|           | Arch Cylinder 9000 .....                                  | 29        |
|           | Arch Cylinder 9100 .....                                  | 30        |
|           | Pusher Cylinder # 20I72 .....                             | 31        |
|           | Cylinder 25TR04 & 25TR08 .....                            | 32        |
|           | 6 Spool Control Valve # 32111 .....                       | 33        |
|           | 1 Spool Control Valve # 32232 .....                       | 34        |
|           | Engine Assembly with Pump .....                           | 35        |
|           | Hub H1000 .....   | 36        |
|           | Hub H2500 .....   | 37        |
|           | Hydraulic System .....                                    | 38        |
|           | Electric circuit .....                                    | 41        |
|           | Traction mechanism option .....                           | 42        |
|           | 1 Spool Control Valve # 640-10004 (SD4 open center) ..... | 43        |
|           | Hydraulic Motor # DH 315 .....                            | 44        |
| <b>9</b>  | <b>Torque Chart .....</b>                                 | <b>45</b> |
| <b>10</b> | <b>Warranty .....</b>                                     | <b>46</b> |



---

---

# INTRODUCTION

---

1

## CONGRATULATIONS!

Thank you for choosing ALBERTA AG-INDUSTRIES LTD. We are confident this equipment will meet your requirements in terms of quality, performance and reliability.

This manual was prepared to assist you in the safe operation of your new AgriPac® Lastic Tuber™. It contains important information which will help you achieve excellent returns with your tubing-machine for years to come.

Please read this manual completely before operating your AgriPac® Lastic Tuber™ and keep it for future reference.

Before starting the machine, you or any other person who will be operating the AgriPac® Lastic Tuber™ must familiarize yourself with the safety recommendations and the operating instructions. Please read carefully and be sure to understand and follow all recommendations and procedures.

In this manual, the right and left sides of the AgriPac® Lastic Tuber™ are identified while standing at the discharge end of the machine and facing it.

If you require additional information on your AgriPac® Lastic Tuber™, please contact your ALBERTA AG-INDUSTRIES LTD. Dealer.

**NOW** take a moment to enter the model, serial number and the date of purchase of your AgriPac® Lastic Tuber™ in the space provided.

When ordering parts from your Dealer, please refer to these numbers for a fast and efficient service. Use ALBERTA AG-INDUSTRIES LTD. parts for replacement.

The model and serial numbers are on the nameplate shown on Fig. 1.



Figure 1

MODEL: \_\_\_\_\_ ✍

SERIAL NO.: \_\_\_\_\_ ✍

DATE OF PURCHASE: \_\_\_\_\_ ✍

---

---

# SAFETY

---

## GENERAL SAFETY

2

### WHEN YOU SEE THIS SYMBOL



**ATTENTION!**

**BE ALERT  
YOUR SAFETY IS INVOLVED**

This symbol «**SAFETY ALERT**» is used in this manual and on the safety decals on the AgriPac® Lastic Tuber™. It warns you of the possibility of danger. Carefully read, understand and follow all safety recommendations before operating the AgriPac® Lastic Tuber™.

- 1) Careful operation is the best assurance against accidents. Carefully read this manual and the motor manual and follow all recommendations before operating your AgriPac® Lastic Tuber™. It is the owner's responsibility to make sure that anyone who will operate the AgriPac® Lastic Tuber™ will read these manuals before operating the equipment.
- 2) Never let a child operate the AgriPac® Lastic Tuber™.
- 3) Do not modify the AgriPac® Lastic Tuber™. Any non authorized modification may affect the efficiency and/or safety of the equipment and will automatically void the warranty.
- 4) Never operate the AgriPac® Lastic Tuber™ with defective parts or if damaged in any way. Have it repaired before operating.
- 5) Make sure all fasteners are in place and properly secured or tightened. Refer to torque chart on page 45.

- 6) Avoid wearing loose fitting clothing when working with the AgriPac® Lastic Tuber™. These could get entangled in moving parts of the equipment and cause accidents.
- 7) Keep motor clean and exempt of dust and debris.
- 8) Before using the AgriPac® Lastic Tuber™, inspect the area where it is to be used and remove any object which could hamper normal operation or damage the plastic tube.
- 9) Hydraulic fluids under pressure can damage your skin. Do not use your hands to locate a leak.
- 10) Plastic bags are impervious to air. Keep them away from children to avoid suffocation.
- 11) When using a tractor equipped with a spear, be extremely careful. Always lower the spear to the ground before leaving your tractor.
- 12) Do not store, spill or use fuel near a flame, a hot engine or stove.

## SAFETY IN OPERATION

### STEP 1 APPLIES ONLY TO THE 9100

- 1) Position the engine outward before you start working with the AgriPac® Lastic Tuber™.
- 2) Be sure there are no obstructions around the equipment and that no one stands near the AgriPac® Lastic Tuber™ when in operation.
- 3) Always refuel equipment when outside and away from flames or sparks.
- 4) Never run the engine inside. Do not operate the engine in a confined or non ventilated area. Carbon monoxide is a colorless, odorless and deadly gas.
- 5) Be careful when adjusting equipment with engine running.

---

---

## ***SAFETY (cont'd)***

---

- 6) Keep hands, feet, hair and clothing away from moving parts.
- 7) Should you need to step onto the AgriPac® Lastic Tuber™ for whatever reasons, **ALWAYS** stop the motor since there is **RISK OF SERIOUS INJURY** if not stopped.
- 8) Do not refill fuel tank with engine running. Always let the engine cool off for a couple of minutes before refilling. Always use approved fuel containers.
- 9) Do not operate the engine if fuel is spilled. Move equipment away from the spill and avoid any spark until the complete evaporation of the fuel.
- 10) Do not smoke while refueling.
- 11) Do not operate engine with any accumulation of hay, leaves, dirt or any other combustible material near the exhaust muffler.
- 12) Avoid touching the hot muffler and cooling fins since they could cause burns to your skin.

### ***SAFETY WITH MAINTENANCE***

- 1) Perform the AgriPac® Lastic Tuber™ maintenance according to the recommendations contained in this manual.
- 2) Stop engine and relieve all hydraulic pressures before doing inspection, maintenance or repairs.
- 3) Do not check spark with spark plug or wire removed. Use the appropriate testing equipment.
- 4) Regularly check fuel lines and fittings for leaks. Replace if necessary.

### ***SAFETY IN TRANSPORT***

- 1) Be sure to engage the two safety locks (A Figure 2) provided for the rear wheels hydraulic cylinders (B Figure 2).

### **STEP 2 APPLIES ONLY TO THE 9100**

- 2) Slide the engine to the inward position (transport position) in order not to exceed the legal width on the road.
- 3) Check local regulations for the transport of your AgriPac® Lastic Tuber™ on the road.
- 4) Be alert when pulling the AgriPac® Lastic Tuber™ on the road. Do not allow anyone to stand on it while in motion.
- 5) The road speed should be such as to maintain full control over steering and braking.
- 6) Be careful while backing up.

### ***SAFETY IN STORAGE***

- 1) Let engine cool and drain fuel from tank.
- 2) Do not let children play in the area where the AgriPac® Lastic Tuber™ is stored.
- 3) Do not leave a Tube installed on the AgriPac® Lastic Tuber™.
- 4) Do not let the AgriPac® Lastic Tuber™ stand on the tires. Lower it to the ground or on wooden blocks. **THIS WILL AVOID ANY ACCIDENTAL CRUSHING OF ANIMALS OR ANYONE WHO COULD CRAWL UNDER THE EQUIPMENT.**

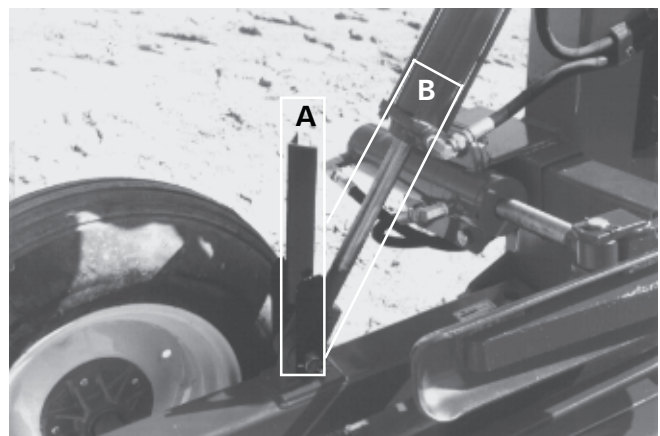

Figure 2

# DECALS

## SAFETY DECALS

The safety decals are affixed wherever special safety precautions are indicated. Locate them on the machine and read them carefully. If a decal is damaged, lost or illegible, install a new one. Each decal is identified with a letter and part number. The following photos indicate where each one must be installed.

3



Figure 3  
Decal A

Part no.: A101

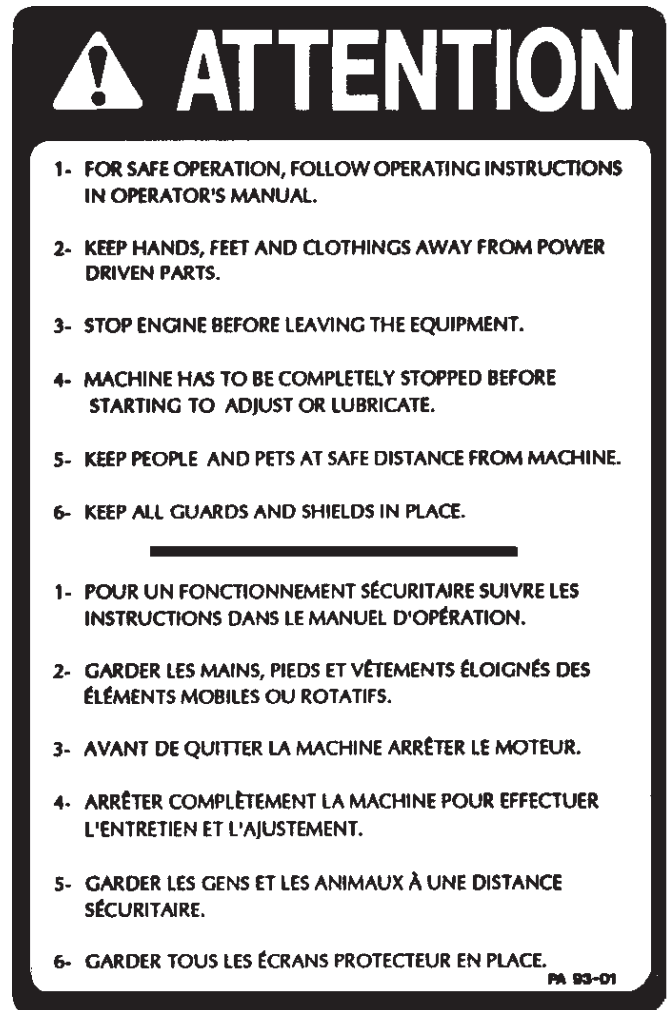

Figure 5  
Decal B

Part no.: A102



Figure 4



Figure 6



---

---

## DECALS (cont'd)

---



Figure 7  
Decal C

Part no.: A103



Figure 8

### MAINTENANCE DECALS

The maintenance decals indicate the points requiring lubrication. Refer to the maintenance section for more details.



Figure 9

Part no.: A104

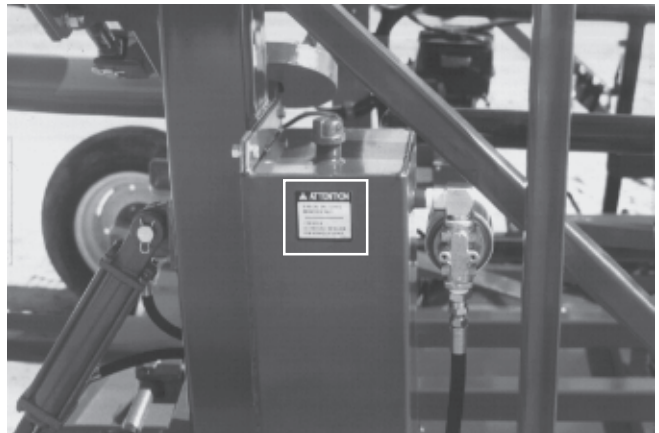

Figure 10



Figure 11

Part no.: A 106

---

# STARTING-UP

---



**4** Figure 12

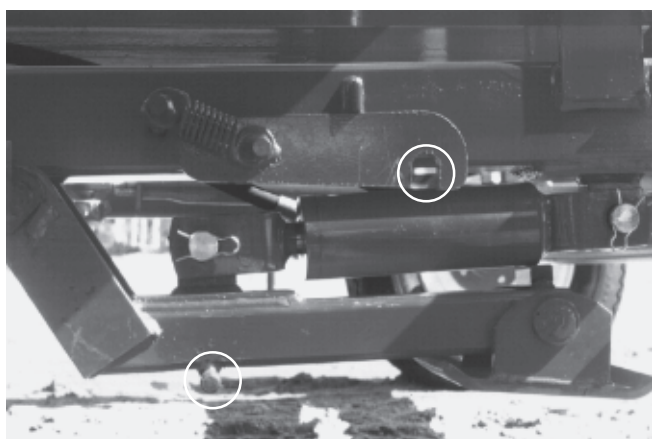

Figure 13

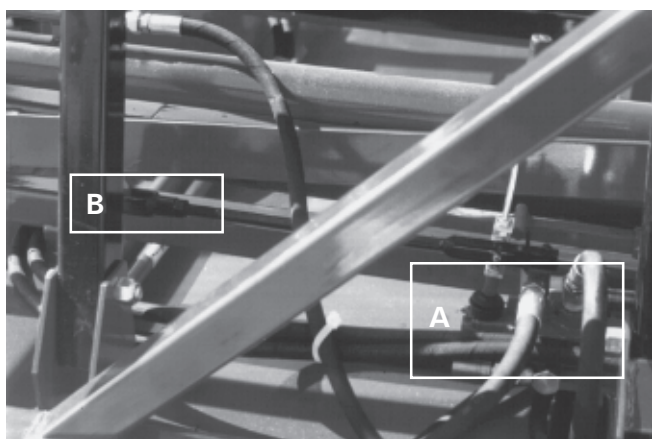

Figure 14

## **BASIC START-UP PROCEDURES**

### **STEP 1 APPLIES ONLY TO THE 9100.**

- 1) The AgriPac® Lastic Tuber™ engine is mounted on a sliding base so it can be easily placed in transport position in order not to exceed the legal width on the road. Do not forget to re-position the engine outward before starting. (Fig. 12)
- 2) Do not forget to unlock the hydraulic jack before lowering and always lock it when in the retracted position. (Fig. 13)
- 3) Verify for adequate tightness of all fastening devices. Refer to torque chart on page 45.
- 4) Lubricate all points and guide mechanisms requiring grease, with a high quality lithium base grease containing molybdenum disulfide (MoS<sub>2</sub>) such as «Esso Unirex EP1 Moly», «DARINA XL-Multi Season Moly, Grade #1» from Shell or equivalent.
- 5) Check oil level in hydraulic reservoir. Use good quality tractor transmission and hydraulic system oil such as «Trans Hydraulic Duratran» from Petro Canada, «DONAX TD» from Shell or equivalent.
- 6) Check tire pressure and adjust according to recommendation indicated on the tires.
- 7) Check engine oil level.
- 8) Check the operation of all hydraulic cylinders.
- 9) Check the operation of the bale pusher mechanism. It must operate freely and return to its starting position automatically. Should the valve (A Fig. 14) not engage positively, adjust the rod end clevis (B Fig. 14).

---

## ***STARTING-UP (cont'd)***

---

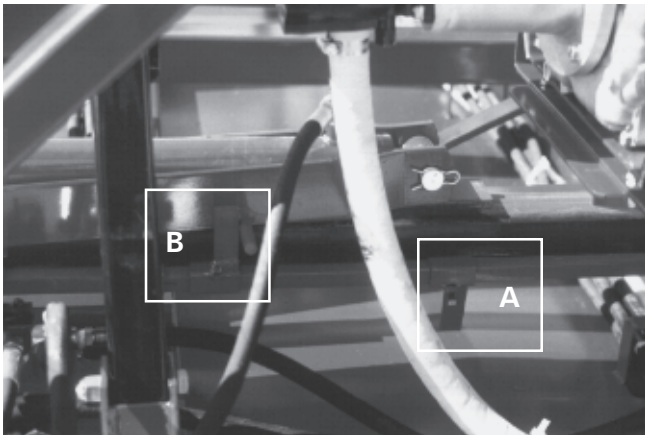

Figure 15



Figure 16



Figure 17

- 10) Check and if necessary, adjust the length of travel of the pusher by changing the position of lug "A" figure 15. To prevent bottoming of the piston, always keep  $\frac{1}{2}$ " to  $\frac{3}{4}$ " of travel at either end of the cylinders. The retracted position is adjusted in the same manner with lug "B" figure 15.
- 11) Check the surface of the stretcher arms for smoothness. Any mark or protrusion could cause tears to the tube.

### ***GROUND PREPARATION***

- 1) Choose a dry and well drained area.
- 2) Level and clean up site where the tubes will be used.
- 3) If possible, provide a sand bed of 2" to 3" (5-8 cm.) thick. This will help reduce damage from rodents.

### ***ADJUSTMENT OF THE AGRIPAC® LASTIC TUBER™***

#### **STEP 1 APPLIES ONLY TO THE 9100**

- 1) Position the six (6) stretcher hydraulic cylinder assemblies according to the size of tube used. Use the inside holes for 4 ft. tubes, 48" to 56" (1.22 to 1.42 m) (Fig.16). Use the outside holes for 5 ft. tubes, 56" to 66" (1.42 to 1.68 m) (Fig.17).
- 2) Locate the rear end of the AgriPac® Lastic Tuber™ approximately 5' (1.5m) away from the point where you want to position the end of the tube. This will compensate if there is some slippage of the first couple of bales until there is enough ground friction to push the AgriPac® Lastic Tuber™ forward.

**4**

---

## STARTING-UP (cont'd)

---

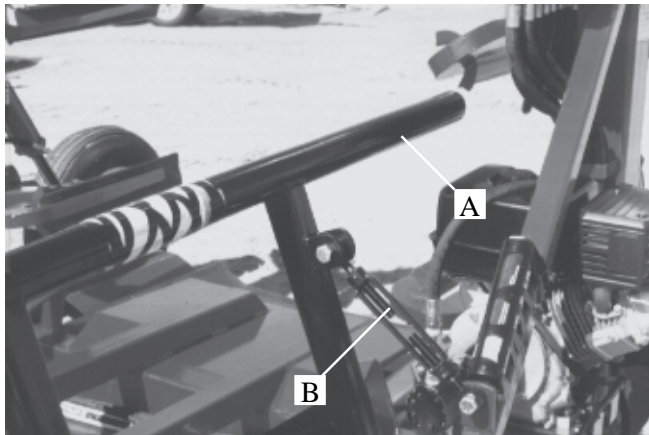

**4** Figure 18



Figure 19

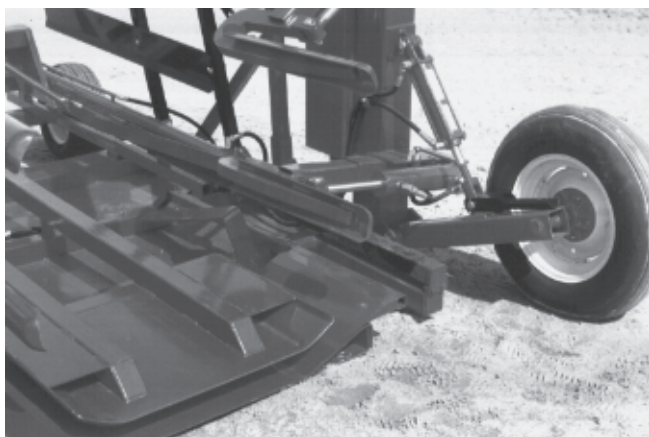

Figure 20

- 3) Adjust guides (A Fig.18) according to the width of the bales. Use turnbuckles provided (B Fig.18).
- 4) Adjust tongue to its most inward position. If there is a risk of interference with the front of the tractor or with uneven ground, it is recommended to remove it. (Fig. 19)
- 5) Adjust rear wheels in order to have a minimum amount of ground friction with the rear end of the AgriPac® Lastic Tuber™ (Fig. 20) while keeping it in contact with the ground.
- 6) For maximum operating speed, you may set the engine to full throttle, although it is preferable to run it a speed closer to your rate of bale supply to machine. This will result in a more economical operation.



---

## STARTING-UP (cont'd)

---

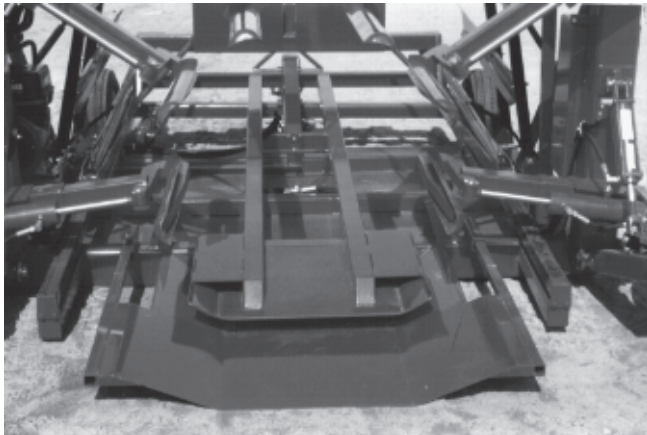

Figure 21



Figure 22



Figure 23

### INSTALLATION OF THE TUBE

To facilitate this procedure, adhere to the following sequence:

- 1) Start engine.
- 2) Close the stretcher arms to the most inward position and pull out the tube support plate. (Fig. 21)
- 3) Install tube on the stretcher arms. Place it so that the tube name is facing outside when it unfolds. Slide it carefully **to the bottom** of the stretcher arms and between the two bottom plates, being careful to remove all wrinkles, since they could cause some tearing of the tube. (Fig. 22)
- 4) At this stage, apply a **SLIGHT AMOUNT OF TENSION** to the tube.  
**9000:** Open each pair of stretcher arms until the end of the internal square tubing reaches the pilot hole of the outer tube. (Fig. 23)  
**9100:** Open each pair of stretcher arms until the pilot hole in the square tubing reaches the lower end of the guide tube. (Fig. 24)
- 5) Do not forget to fully retract the tube support plate until it is locked in place. (Fig. 25)

4

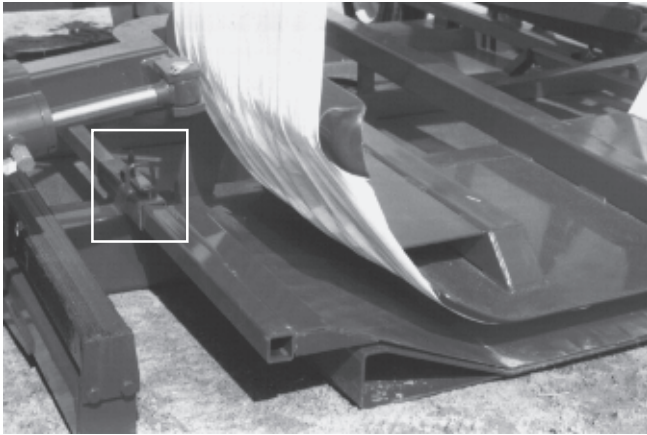

Figure 24

---

## STARTING-UP (cont'd)

---



4 Figure 25

- 6) Again check the tube position (Fig. 26) and eliminate any wrinkles. Next, cut off all ties (Fig. 27).
- 7) Now it's time to close the end of the tube. Pull out the outer ply for approximately 36" (91 cm) and tie properly. (Fig. 28 and Fig. 29)
- 8) **STRETCH THE TUBE ONLY WHEN READY TO OPERATE.** It may lose some of its memory if kept stretched for a too long period of time. If you must stop loading bales for a while, **BRING THE TUBE DOWN TO A MODERATE TENSION.**



Figure 26



Figure 28



Figure 27



Figure 29

---

## STARTING-UP (cont'd)

---

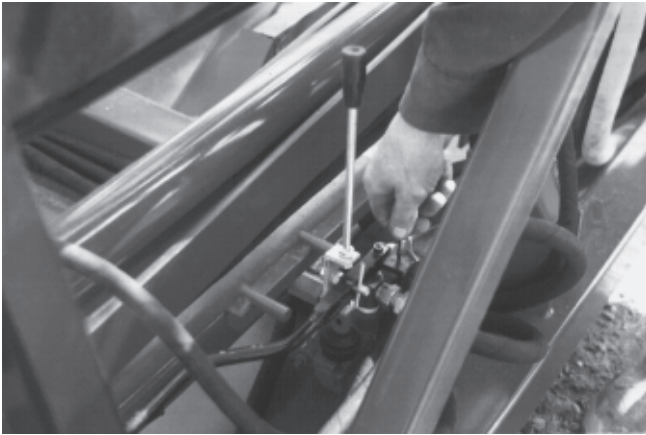

Figure 30



Figure 31



Figure 32

### OPERATION

- 1) Before loading the first bale, disengage the pusher control valve by flipping the safety lock outward. (Fig. 30) Load the first bale on the machine, operate the control valve manually until the bale approaches the arms and stop it there.
- 2) Stretch the tube by operating the three valves **SIMULTANEOUSLY** (Fig. 31) to obtain a **CLEARANCE OF APPROXIMATELY 2" to 3"** between the bale and the tube (Fig. 32). Readjust stretcher arms individually if necessary.
- 3) At this point, check again the rear wheels adjustment for **minimum** ground friction (step 5, page 12) before engaging the bale pusher valve.
- 4) Reset the safety lock by pushing it fully inward. Engage the valve manually to complete the cycle automatically.
- 5) It is recommended to use a spear (single or double) on your loader to drop the bales onto the AgriPac® Lastic Tuber™.
- 6) Once the bale is dropped, back up immediately to make room for the AgriPac® Lastic Tuber™'s forward movement.
- 7) After the first 3 or 4 bales, lower the rear of the AgriPac® Lastic Tuber™ to increase ground friction. This will ensure that the bales will be real tight against each other in the tube.
- 8) You can steer SilaTube with a lever on the control valve in order to make a straight row.
- 9) Towards the end of the tube, keep at least 36" (91 cm) of plastic, in order to allow for proper closure of the tube.

4



---

## STARTING-UP (cont'd)

---

4



Figure 33



Figure 34



Figure 35

- 10) To push the last bale into the tube, install the pusher extension supplied with the AgriPac® Lastic Tuber™. (Fig. 33)
- 11) Manually engage the pusher valve to initiate the last bale cycle. (Fig. 34)
- 12) Remove the pusher extension and store it in its receptacle on the right hand side of the AgriPac® Lastic Tuber™. (Fig. 35)
- 13) Close up end of tube as previously described. (Fig. 28 & Fig. 29)
- 14) Regularly inspect the tubes. If torn or punctured, repair openings with proper means.



---

---

# *MAINTENANCE*

---

- 1) Refer to the manufacturer's instructions for the engine.
- 2) Use a high quality lithium base grease containing molybdenum disulfide ( $\text{MoS}_2$ ) such as «Esso Unirex EP1 Moly», «DARINA XL-Multi Season Moly, Grade #1» from Shell or equivalent.
- 3) Wipe off all grease fittings with a clean cloth before adding grease in order to avoid injecting dirt or sand.
- 4) Repair or replace damaged grease fittings.
- 5) Lubricate long pusher guides every 8 hours of operation.
- 6) Lubricate stretcher arms guides every 20 hours of operation.
- 7) Lubricate all grease fittings every 20 hours of operation.
- 8) Open, clean and lubricate wheel bearings once a year.
- 9) Check oil level in hydraulic reservoir every 20 hours of operation. If necessary add good quality trans hydraulic oil such as «Trans Hydraulic Duratran» from Petro-Canada, «DONAX TD» from Shell or equivalent.
- 10) Change oil filter after the first 50 hours of operation and then every 250 hours. Use replacement filter no. K-22001, Alberta Ag-Industries Ltd. part No. 32007.
- 11) Check all nuts and bolts once a year. If necessary use torque chart on page 45.
- 12) Check all bolts on wheels after first 5 hours of operation and then every 50 hours.
- 13) Check tire pressure every 50 hours. Adjust according to manufacturer's recommendation indicated on the tires.

---

---

## ***STORAGE***

---

- 1) Store the AgriPac® Lastic Tuber™ in a cool, dry place.
- 2) Lower the AgriPac® Lastic Tuber™ frame on wooden blocks.
- 3) Keep tires off the ground and cover them if left exposed to the sun.
- 4) Keep all piston rods in the retracted position. This will assure better protection against the elements.
- 5) Clean your AgriPac® Lastic Tuber™.
- 6) Touch-up or repaint if necessary.
- 7) Lubricate all points before storage.
- 8) Drain all fuel from tank and follow engine manufacturer's storage recommendations.

# SPECIFICATIONS

| AgriPac® Lastic Tuber™                                  | 9000  | 9100  |
|---|---|---|
| Overall length at work                                  | 153" (3.89 m)                                       | 153" (3.89 m)                                       |
| Overall length in transport                             | 176" (4.47 m)                                       | 176" (4.47 m)                                       |
| Overall width at work                                   | 102" (2.59 m)                                       | 112" (2.85 m)                                       |
| Overall width in transport                              | 102" (2.59 m)                                       | 100" (2.54 m)                                       |
| Overall height in transport                             | 92" (2.34 m)  | 93" (2.36 m)  |
| Bale diameter   | 48" to 56" (1.22 à 1.42 m)                          | 48" to 66" (1.22 à 1.68 m)                          |
| Adaptor for stretcher arm for bales of smaller diameter | bales 44" to 52" (1.12 à 1.32 m)<br>Option (P-6210) | bales 44" to 52" (1.12 à 1.32 m)<br>Option (P-6310) |
| Engine  | HONDA 9 HP  | HONDA 9 HP  |
| Manual starting   | Standard  | Standard  |
| Electric starting                                       | Option  | Option  |
| Two stages hyd. pump                                    | 4 gal / 11 gal<br>Engages at 1100 psi               | 4 gal / 11 gal<br>Engages at 1100 psi               |
| 6 spool control valve                                   | Adjusted at 2800 psi                                | Adjusted at 2800 psi                                |
| 1 spool control valve                                   | Adjusted at 1800 psi                                | Adjusted at 1800 psi                                |
| Front hub   | cap. 1000 lbs (450 kg) 4 bolts                      | cap. 2500 lbs (1136 kg) 5 bolts                     |
| Rear hub  | cap. 2500 lbs (1136 kg) 5 bolts                     | cap. 2500 lbs (1136 kg) 5 bolts                     |
| Front rim   | 10" x 6" - 4 bolts                                  | 10" x 6" - 5 bolts                                  |
| Rear rim  | 15" x 5" - 5 bolts                                  | 15" x 6" - 5 bolts                                  |
| Front tires   | 20.5" x 8" x 10" - 4 plys (with tube)               | 20.5" x 8" x 10" - 4 plys (with tube)               |
| Rear tires  | 6.7" x 15" - 6 plys (with tube)                     | 7.6" x 15" - 6 plys (with tube)                     |
| Performance   | 70 to 100 bales per hour                            | 70 to 100 bales per hour                            |
| Oil tank capacity                                       | 5.75 gal US (4.75 gal imp.) (21.75 liters)          | 5.75 gal US (4.75 gal imp.) (21.75 liters)          |
| Hyd. steering adjustment                                | Standard  | Standard  |
| Working lights  | Option (P-6245)                                     | Option (P-6245)                                     |
| Road lights   | Option (P-6240)                                     | Option (P-6240)                                     |
| Hitch weight  | 1360 lbs (612 kg) app.                              | 1410 lbs (635 kg) app.                              |
| Total weight  | 3675 lbs (1655 kg) app.                             | 3900 lbs (1756 kg) app.                             |

Design and specifications subject to change without notice.

## PLASTIC TUBES TO USE ACCORDING TO BALES DIAMETER

|             |   |   |
|-------------|---|---|
| 9000 & 9100 | For bales 44" to 52" (1.12 à 1.32m) diameter  | Lay flat 69" (1.75 m) (Use with adaptor for stretcher arms) |
| 9000 & 9100 | For bales 48" to 56" (1.22 à 1.42 m) diameter | Lay flat 73½" (1.87 m)                                      |
| 9100 ONLY   | For bales 56" to 66" (1.42 à 1.68 m) diameter | Lay flat 86" (2.18 m)                                       |

# AGRIPAC® LASTIC TUBER™ 9000 ASSEMBLY

170-02361

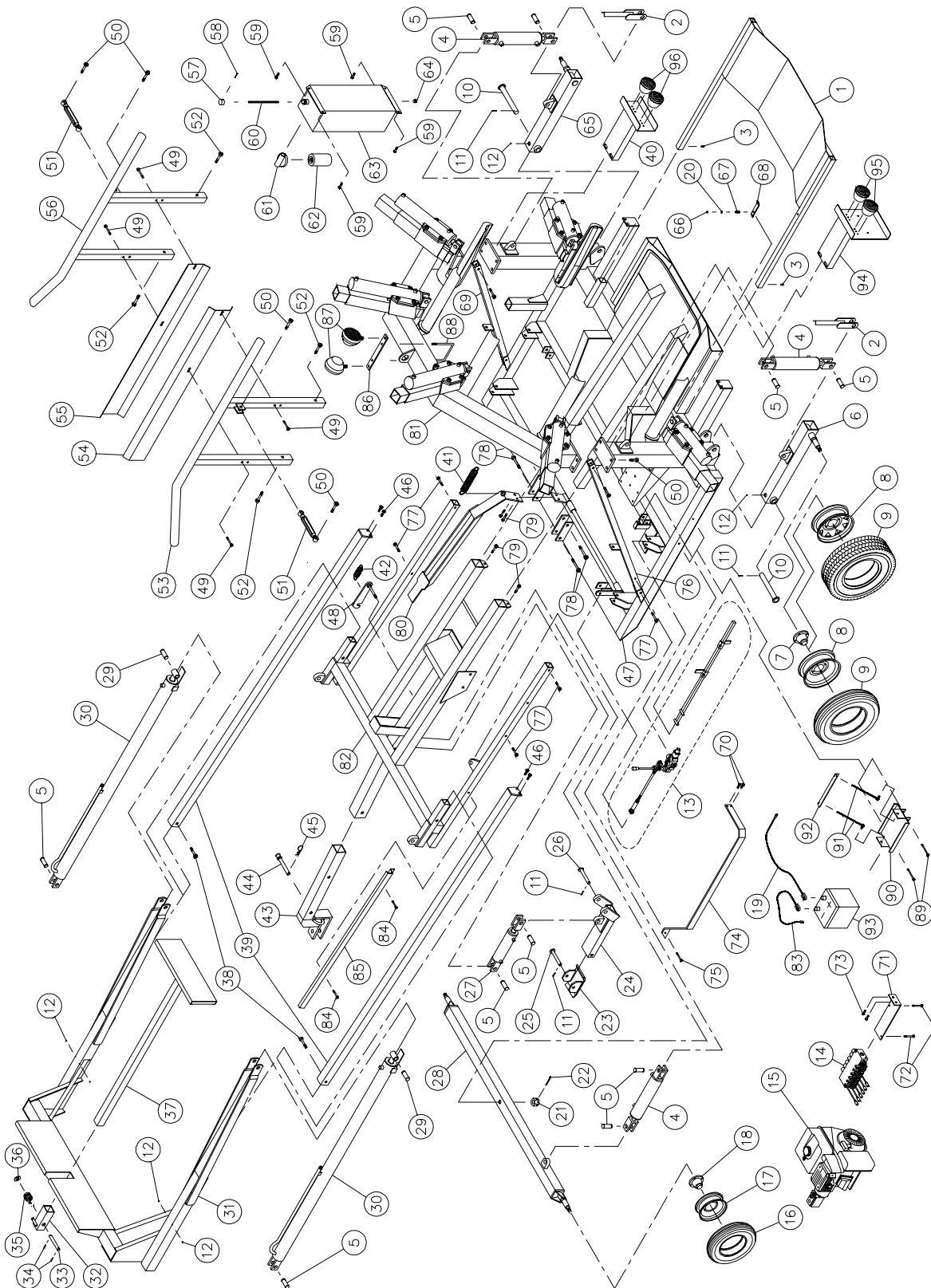

# AGRIPAC® LASTIC TUBER™ 9000 ASSEMBLY (cont'd)

| REF. | PART #      | DESCRIPTION   | QTY  |
|------|-------------|---|------|
| 1    | 32107       | Tube support plate .....  | 1    |
| 2    | 32108       | Safety locking mechanism for rear wheels .....  | 2    |
| 3    | Std.        | Bolt ¼" NC x ¾" lg + nut & lock washer .....  | 2    |
| 4    | 25TR08      | Cylinder 2.5" x 8" standard (see details p. 32) .....                                 | 3    |
| 5    | D-60051     | Pin 1" x 3" lg .....  | 10   |
| 6    | 110-03441   | Left rear axle .....  | 1    |
| 7    | 32218       | Hub H-2500 (see details p. 37) .....  | 2    |
| 8    | R-1555      | Rim 15 x 5 x 5 .....  | 2    |
| 8    | R-1575RT    | Rim 15 x 7 x 5 (2) .....  | opt. |
| 9    | PN-6.7015   | Tire 6.7 x 15 - 6 ply + tube 6.70 x 15 TR-15 .....                                    | 2    |
| 9    | PN-7.0015RT | Tire 7.00 x 15 (2) .....  | opt. |
| 10   | 32034       | Pin for rear axle (9000) .....  | 2    |
| 11   | Std.        | Cotter pin 5/32" x 1½" lg .....   | 4    |
| 12   | Std.        | Grease fitting ¼"-28 straight .....   | 6    |
| 13   | - - -       | Automatic system detail (see details p. 28) .....                                     | 1    |
| 14   | 32111       | 6 spool control valve (see details p. 33) .....                                       | 1    |
| 15   | - - -       | HONDA 9 HP engine assembled with pump (see details p. 35) .....                       | 1    |
| 15   | - - -       | HONDA 9 HP engine with electric starter assembled with pump (see details p. 35) ..... | opt. |
| 16   | PN-20.58    | Tire 20.5 x 8 x 10 - 4 ply .....  | 2    |
| 17   | R-1064      | Rim 10 x 6 x 4 .....  | 2    |
| 18   | 53015       | Hub H-1000 (see details p. 36) .....  | 2    |
| 19   | 51606       | Battery cable 4G x 30" lg .....   | opt. |
| 20   | 376-32200   | Flat washer 3/16" .....   | 1    |
| 21   | 32114       | Castle nut 1" - 8 .....   | 1    |
| 22   | Std.        | Cotter pin 5/32" x 2" .....   | 1    |
| 23   | 32115       | Base, hydraulic jack .....  | 1    |
| 24   | 32116       | Body, hydraulic jack .....  | 1    |
| 25   | 32117       | Pin for hydraulic jack base .....   | 1    |
| 26   | 32118       | Pin for hydraulic jack body .....   | 1    |
| 27   | 25TR04      | Cylinder 2.5 x 4" standard (see details p. 32) .....                                  | 1    |
| 28   | 32119       | Front axle assembly (9000) .....  | 1    |
| 29   | 32019       | Pin 1" .....  | 2    |
| 30   | 20172       | Cylinder 2" x 72" lg (see details p. 31) .....  | 2    |
| 31   | 32205       | 9000 bale ram frame .....   | 1    |
| 32   | 32121       | Ram extension support .....   | 1    |
| 33   | 32122       | Pin .....   | 1    |
| 34   | Std.        | Cotter pin 3/16" x 1¾" lg .....   | 2    |
| 35   | 32123       | Ram extension support spring .....  | 1    |
| 36   | Std.        | Washer 1" .....   | 1    |
| 37   | 32124       | Ram extension .....   | 1    |
| 38   | Std.        | Bolt 5/8" NC x 3½" lg + nut & lock washer .....                                       | 2    |
| 39   | 32022       | Ram guide .....   | 2    |
| 40   | 110-03501   | Right support for flasher .....   | opt. |
| 41   | 1201        | Tension spring 1/4" x 1 13/16" x 10 1/2" lg .....                                     | 1    |
| 42   | 32008       | Tension spring 1¼" x 3½" lg .....   | 1    |
| 43   | 32199       | Drawbar .....   | 1    |
| 44   | 32024       | Drawbar pin .....   | 1    |
| 45   | DA3070-56   | Hitch pin clip .....  | 1    |
| 46   | Std.        | Bolt ½" NC x 1½" lg + nut & lock washer .....   | 4    |
| 47   | 120-00641   | 9000 main frame .....   | 1    |
| 48   | 32128       | Locking mechanism for jack .....  | 1    |
| 49   | Std.        | Bolt 7/16" NC x 3" lg + nut + lock washer + flat washer .....                         | 4    |
| 50   | Std.        | Bolt 5/8" NC x 2½" lg + nylon locknut .....   | 12   |
| 51   | 32014       | Turnbuckle 10" .....  | 2    |
| 52   | Std.        | Bolt 5/8" NC x 3½" lg + nylon locknut .....   | 4    |
| 53   | 32025       | Left bale guide (9000) .....  | 1    |

# AGRIPAC® LASTIC TUBER™ 9000 ASSEMBLY (cont'd)

| REF. | PART #    | DESCRIPTION  | QTY  |
|------|-----------|--|------|
| 54   | 130-04281 | Left protector .....   | 1    |
| 55   | 130-04271 | Right protector .....  | 1    |
| 56   | 32028     | Right bale guide (9000) .....  | 1    |
| 57   | 32029     | Oil reservoir cap .....  | 1    |
| 58   | Std.      | Roll pin 5/32" x 1 3/4" .....  | 1    |
| 59   | Std.      | Bolt 7/16" NC x 1" + nut & lock washer .....                                     | 4    |
| 60   | 32030     | Dip stick .....  | 1    |
| 61   | 32031     | Hydraulic oil filter adaptor FSP107-1E DNN .....                                 | 1    |
| 62   | 32007     | Paper filter K-22001 .....   | 1    |
| 63   | 32033     | Oil reservoir .....  | 1    |
| 64   | 32032     | Drain plug 1/2" .....  | 1    |
| 65   | 110-03451 | Right rear axle .....  | 1    |
| 66   | Std.      | Nylon locknut 1/4" NC .....  | 1    |
| 67   | 32130     | Compression spring 13/32" x 1 1/2" lg .....                                      | 1    |
| 68   | 32131     | Locking device for support plate .....   | 1    |
| 69   | 160-02081 | Arch brace (right side) .....  | 1    |
| 70   | Std.      | Bolt 3/8" NC x 1 1/4" lg + nylon locknut .....                                   | 2    |
| 71   | 110-11651 | Valve support .....  | 1    |
| 72   | Std.      | Bolt 5/16" NC x 2 1/2" lg + nylon locknut .....                                  | 2    |
| 73   | Std.      | Bolt 7/16" NC x 3/4" lg + lockwasher & flat washer .....                         | 2    |
| 74   | 32208     | Guard .....  | 1    |
| 75   | Std.      | Bolt 3/8" NC x 3" lg + nylon locknut .....                                       | 1    |
| 76   | 160-02221 | Arch brace (left side) .....   | 1    |
| 77   | Std.      | Bolt 1/2" NC x 3 1/2" lg + nylon locknut .....                                   | 8    |
| 78   | Std.      | Bolt 5/8" NC x 4 1/2" lg + nylon locknut .....                                   | 4    |
| 79   | Std.      | Bolt 1/2" NC x 1 1/2" lg + nylon locknut .....                                   | 4    |
| 80   | 110-03311 | Trigger .....  | 1    |
| 81   | 120-03031 | Arch frame .....   | 1    |
| 82   | 120-00631 | Support structure for ram guide .....  | 1    |
| 83   | 51607     | Battery cable 4G x 10" lg .....  | opt. |
| 84   | Std.      | Bolt 3/8" NC x 2 3/4" lg + nylon locknut & flat washer .....                     | 2    |
| 85   | 32207     | Guard .....  | 1    |
| 86   | 140-02901 | Working lights retaining plate .....   | opt. |
| 87   | 110-04771 | 2 Working lights .....   | opt. |
| 88   | 150-00971 | "U" bolt 3/8" NC + 2 nylon locknut .....   | opt. |
| 89   | Std.      | 2 Bolts 5/16" NC x 4" lg + nylon locknut .....                                   | opt. |
| 90   | 110-04831 | Battery support .....  | opt. |
| 91   | 110-11511 | 2 Threaded rods for battery hold down + nylon locknut 3/8" NC and 7/16" NC ..... | opt. |
| 92   | 130-05751 | Battery hold down .....  | opt. |
| 93   | 32283     | Battery 12V-540A .....   | opt. |
| 94   | 110-03511 | Left support for flasher .....   | opt. |
| 95   | 32228     | 2 Left flashers with license light .....   | opt. |
| 96   | 32229     | 2 Right flashers .....   | opt. |



# AGRIPAC® LASTIC TUBER™ 9100 ASSEMBLY

170-02371

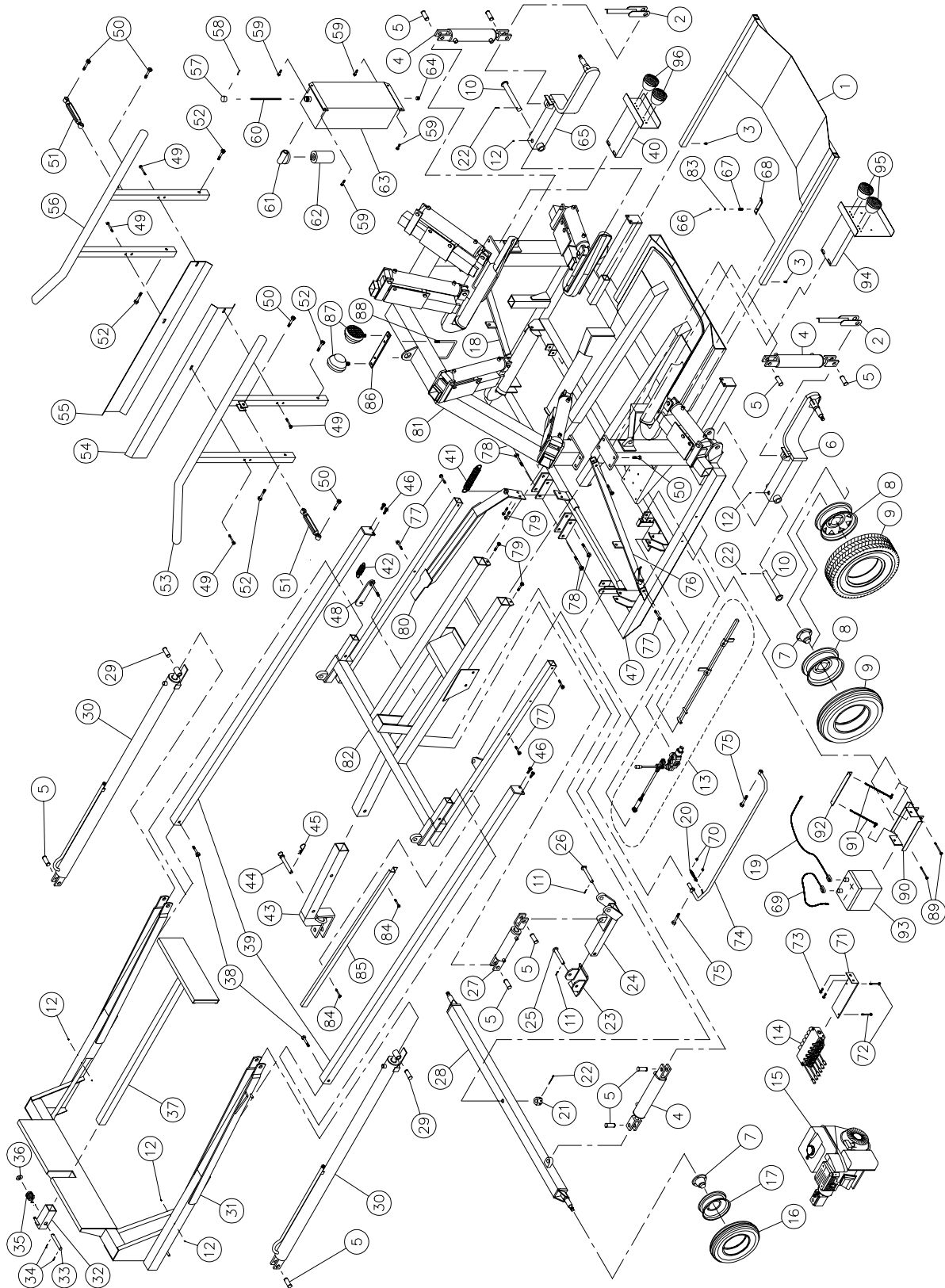

# AGRIPAC® LASTIC TUBER™ 9100 ASSEMBLY (cont'd)

| REF. | PART #      | DESCRIPTION   | QTY  |
|------|-------------|---|------|
| 1    | 32107       | Tube support plate .....  | 1    |
| 2    | 32108       | Safety locking mechanism for rear wheels .....  | 2    |
| 3    | Std.        | Bolt ¼" NC x ¾" lg + nut & lock washer .....  | 2    |
| 4    | 25TR08      | Cylinder 2.5" x 8" standard (see details p. 32) .....                                 | 3    |
| 5    | D-60051     | Pin 1" x 3" lg .....  | 10   |
| 6    | 110-03442   | Left rear axle .....  | 1    |
| 7    | 32218       | Hub H-2500 (see details p. 37) .....  | 4    |
| 8    | R-1565      | Rim 15 x 6 x 5 .....  | 2    |
| 8    | R-1575RT    | Rim 15 x 7 x 5 (2) .....  | opt. |
| 9    | PN-7.6015   | Tire 6.7 x 15 - 6 ply + tube 7.6 x 15 TR-15 .....                                     | 2    |
| 9    | PN-7.0015RT | Tire 7.00 x 15 (2) .....  | opt. |
| 10   | 32093       | Pin for rear axle (9100) .....  | 2    |
| 11   | Std.        | Cotter pin 5/32" x 1½" lg .....   | 2    |
| 12   | Std.        | Grease ¼"-28 fitting .....  | 6    |
| 13   | - - -       | Automatic system detail (see details p. 28) .....                                     | 1    |
| 14   | 32111       | 6 spool control valve (see details p. 33) .....                                       | 1    |
| 15   | - - -       | HONDA 9 HP engine assembled with pump (see details p. 35) .....                       | 1    |
| 15   | - - -       | HONDA 9 HP engine with electric starter assembled with pump (see details p. 35) ..... | opt. |
| 16   | PN-20.58    | Tire 20.5 x 8 x 10 - 4 ply .....  | 2    |
| 17   | R-1065      | Rim 10 x 6 x 5 .....  | 2    |
| 18   | 160-02081   | Arch brace (right side) .....   | 1    |
| 19   | 51606       | Battery cable 4G x 30" lg .....   | opt. |
| 20   | 16107       | Extension spring .....  | 1    |
| 21   | 32114       | Castle nut 1" - 8 .....   | 1    |
| 22   | Std.        | Cotter pin 5/32" x 2" .....   | 3    |
| 23   | 32115       | Base, hydraulic jack .....  | 1    |
| 24   | 32116       | Body, hydraulic jack .....  | 1    |
| 25   | 32117       | Pin for hydraulic jack base .....   | 1    |
| 26   | 32118       | Pin for hydraulic jack body .....   | 1    |
| 27   | 25TR04      | Cylinder 2.5 x 4" standard (see details p. 32) .....                                  | 1    |
| 28   | 110-03461   | Front axle assembly (9100) .....  | 1    |
| 29   | 32019       | Pin 1" .....  | 2    |
| 30   | 20172       | Cylinder 2" x 72" lg (see details p. 31) .....  | 2    |
| 31   | 32216       | 9100 bale ram frame .....   | 1    |
| 32   | 32121       | Ram extension support .....   | 1    |
| 33   | 32122       | Pin .....   | 1    |
| 34   | Std.        | Cotter pin 3/16" x 1¾" lg .....   | 2    |
| 35   | 32123       | Ram extension support spring .....  | 1    |
| 36   | Std.        | Washer 1" .....   | 1    |
| 37   | 32124       | Ram extension .....   | 1    |
| 38   | Std.        | Bolt 5/8" NC x 3½" lg + nut & lock washer .....                                       | 2    |
| 39   | 32022       | Ram guide .....   | 2    |
| 40   | 110-03501   | Right support for flasher .....   | opt. |
| 41   | 1201        | Tension spring 1/4" x 1 13/16" x 10 1/2" lg .....                                     | 1    |
| 42   | 32008       | Tension spring 1¼" x 3½" lg .....   | 1    |
| 43   | 32199       | Drawbar .....   | 1    |
| 44   | 32024       | Drawbar pin .....   | 1    |
| 45   | DA3070-56   | Hitch pin clip 5/32" .....  | 1    |
| 46   | Std.        | Bolt ½" NC x 1½" lg + nut & lock washer .....   | 4    |
| 47   | 32217       | 9100 main frame .....   | 1    |
| 48   | 32128       | Locking mechanism for jack .....  | 1    |
| 49   | Std.        | Bolt 7/16" NC x 3" lg + nut + lock washer + flat washer .....                         | 4    |
| 50   | Std.        | Bolt 5/8" NC x 2½" lg + nylon locknut .....   | 12   |
| 51   | 32014       | Turnbuckle 10" .....  | 2    |
| 52   | Std.        | Bolt 5/8" NC x 3½" lg + nylon locknut .....   | 4    |
| 53   | 32165       | Left bale guide (9100) .....  | 1    |



# AGRIPAC® LASTIC TUBER™ 9100 ASSEMBLY (cont'd)

| REF. | PART #    | DESCRIPTION  | QTY  |
|------|-----------|--|------|
| 54   | 130-04281 | Left protector .....   | 1    |
| 55   | 130-04271 | Right protector .....  | 1    |
| 56   | 32166     | Right bale guide (9100) .....  | 1    |
| 57   | 32029     | Oil reservoir cap .....  | 1    |
| 58   | Std.      | Roll pin 5/32" x 1 3/4" .....  | 1    |
| 59   | Std.      | Bolt 7/16" NC x 1" + nut & lock washer .....                                     | 4    |
| 60   | 32030     | Dip stick .....  | 1    |
| 61   | 32031     | Hydraulic oil filter adaptor FSP107-1E DNN .....                                 | 1    |
| 62   | 32007     | Paper filter K-22001 .....   | 1    |
| 63   | 110-06241 | Oil reservoir .....  | 1    |
| 64   | 32032     | Drain plug 1/2" .....  | 1    |
| 65   | 110-03452 | Right rear axle .....  | 1    |
| 66   | Std.      | Nylon locknut 1/4" NC .....  | 1    |
| 67   | 32130     | Compression spring 13/32" x 1 1/2" lg .....                                      | 1    |
| 68   | 32131     | Locking device for support plate .....   | 1    |
| 69   | 51607     | Battery cable 4G x 10" lg .....  | opt. |
| 70   | Std.      | Nylon locknut 5/16" NC .....   | 2    |
| 71   | 110-11651 | Valve support .....  | 1    |
| 72   | Std.      | Bolt 5/16" NC x 2 1/2" lg + nylon locknut .....                                  | 2    |
| 73   | Std.      | Bolt 7/16" NC x 3/4" lg + lock washer & flat washer .....                        | 2    |
| 74   | 110-06301 | Guard .....  | 1    |
| 75   | Std.      | Bolt 5/8" NC x 3" lg + nylon locknut .....                                       | 2    |
| 76   | 160-00271 | Arch brace (left side) .....   | 1    |
| 77   | Std.      | Bolt 1/2" NC x 3 1/2" lg + nylon locknut .....                                   | 8    |
| 78   | Std.      | Bolt 5/8" NC x 4 1/2" lg + nylon locknut .....                                   | 4    |
| 79   | Std.      | Bolt 1/2" NC x 1 1/2" lg + nylon locknut .....                                   | 4    |
| 80   | 32213     | Trigger .....  | 1    |
| 81   | 120-00981 | Arch frame .....   | 1    |
| 82   | 32215     | Support structure for ram guide .....  | 1    |
| 83   | 376-32200 | Flat washer 3/16 .....   | 1    |
| 84   | Std.      | Bolt 3/8" NC x 2 3/4" lg + nylon locknut & flat washer .....                     | 2    |
| 85   | 32207     | Guard .....  | 1    |
| 86   | 140-02901 | Working lights retaining plate .....   | opt. |
| 87   | 110-04771 | 2 Working lights .....   | opt. |
| 88   | 150-00971 | "U" bolt 3/8" NC + 2 nylon locknut .....   | opt. |
| 89   | Std.      | 2 Bolts 5/16" NC x 4" lg + nylon locknut .....                                   | opt. |
| 90   | 110-04831 | Battery support .....  | opt. |
| 91   | 110-11511 | 2 Threaded rods for battery hold down + nylon locknut 3/8" NC and 7/16" NC ..... | opt. |
| 92   | 130-05751 | Battery hold down .....  | opt. |
| 93   | 32283     | Battery 12V-540A .....   | opt. |
| 94   | 110-03511 | Left support for flasher .....   | opt. |
| 95   | 32228     | 2 Left flashers with license light .....   | opt. |
| 96   | 32229     | 2 Right flashers .....   | opt. |

# DETAIL OF ARCH MODEL 9000

170-00751

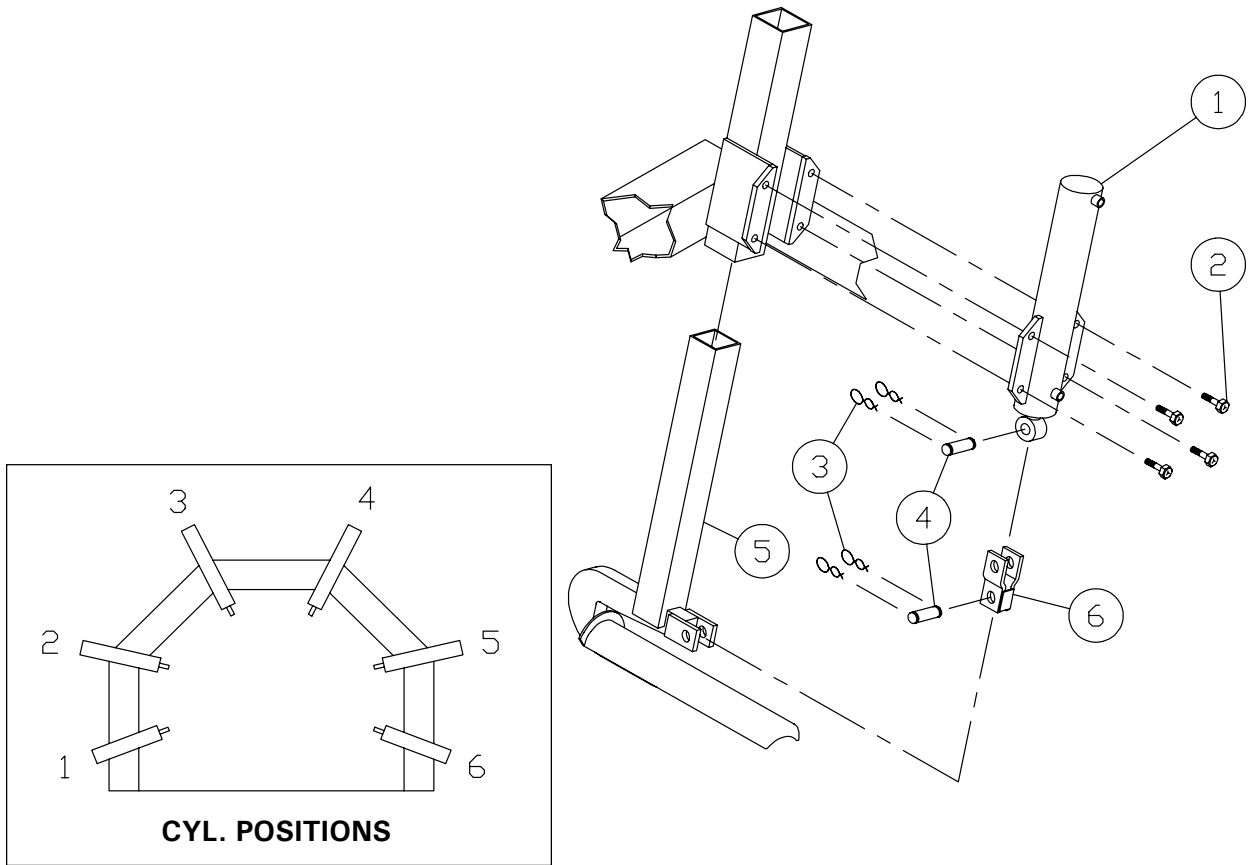

**CYL. POSITIONS**

| REF.                         | PART #    | DESCRIPTION                                   | QTY CYL. POSITION # |   |   |   |   |   |
|------------------------------|-----------|---|---------------------|---|---|---|---|---|
|                              |           |   | 1                   | 2 | 3 | 4 | 5 | 6 |
| 1                            | 30Z10     | Cylinder .....                                | 1                   | - | - | - | - | 1 |
| 1                            | 30Z15     | Cylinder .....                                | -                   | 1 | - | - | 1 | - |
| 1                            | 30Z17     | Cylinder .....                                | -                   | - | 1 | 1 | - | - |
| 2                            | Std.      | Bolt 5/8" NC x 2" lg + nylon locknut .....    | 4                   | 4 | 4 | 4 | 4 | 4 |
| 3                            | Std.      | Hair pin 1/8" .....                           | 2                   | 2 | 2 | 2 | 2 | 2 |
| 4                            | Std.      | Pin 1" .....                                  | 1                   | 1 | 1 | 1 | 1 | 1 |
| 5                            | 110-12171 | Stretcher arm .....                           | 1                   | - | - | - | - | 1 |
| 5                            | 110-12181 | Stretcher arm .....                           | -                   | 1 | 1 | 1 | 1 | - |
| 6                            | 110-06171 | Adaptor for 44" to 50" bales (optional) ..... | -                   | - | 1 | 1 | - | - |
| (includes 2 no. 3 & 1 no. 4) |           |   |                     |   |   |   |   |   |

**8**

# DETAIL OF ARCH MODEL 9100

170-00761

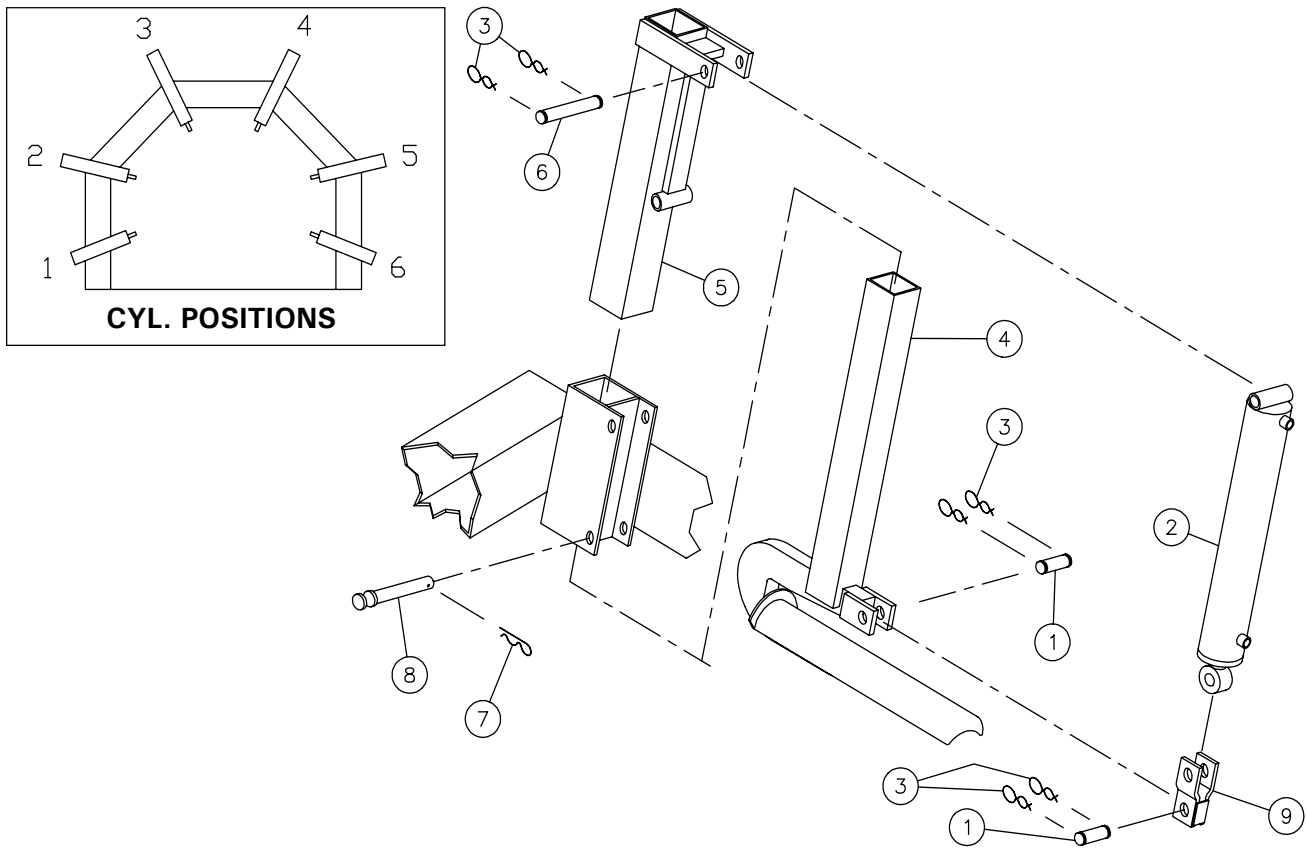

| REF.                         | PART #    | DESCRIPTION                                   | QTY CYL POSITION # |   |   |   |   |   |
|------------------------------|-----------|---|--------------------|---|---|---|---|---|
|                              |           |   | 1                  | 2 | 3 | 4 | 5 | 6 |
| 1                            | Std.      | Pin 1" x 3" lg .....                          | 1                  | 1 | 1 | 1 | 1 | 1 |
| 2                            | 30H10     | Cylinder .....                                | 1                  | - | - | - | - | 1 |
| 2                            | 30H17     | Cylinder .....                                | -                  | 1 | 1 | 1 | 1 | - |
| 3                            | Std.      | Hair pin 1/8" .....                           | 4                  | 4 | 4 | 4 | 4 | 4 |
| 4                            | 110-12191 | Stretcher arm .....                           | 1                  | - | - | - | - | 1 |
| 4                            | 110-12201 | Stretcher arm .....                           | -                  | 1 | - | - | 1 | - |
| 4                            | 110-12211 | Stretcher arm .....                           | -                  | - | 1 | 1 | - | - |
| 5                            | 110-06131 | Stretcher arm guide .....                     | 1                  | - | - | - | - | 1 |
| 5                            | 110-06141 | Stretcher arm guide .....                     | -                  | 1 | - | - | 1 | - |
| 5                            | 32159     | Stretcher arm guide .....                     | -                  | - | 1 | 1 | - | - |
| 6                            | 32160     | Pin 1" x 5" lg .....                          | 1                  | 1 | 1 | 1 | 1 | 1 |
| 7                            | Std.      | Hitch pin clip 3/16" .....                    | 1                  | 1 | 1 | 1 | 1 | 1 |
| 8                            | 32161     | Pin 1" x 5 1/4" lg .....                      | 1                  | 1 | 1 | 1 | 1 | 1 |
| 9                            | 110-06181 | Adaptor for 44" to 50" bales (optional) ..... | -                  | - | 1 | 1 | - | - |
| (includes 1 no. 1 & 2 no. 3) |           |   |                    |   |   |   |   |   |

**8**

# AUTOMATIC SYSTEM DETAIL

170-00351

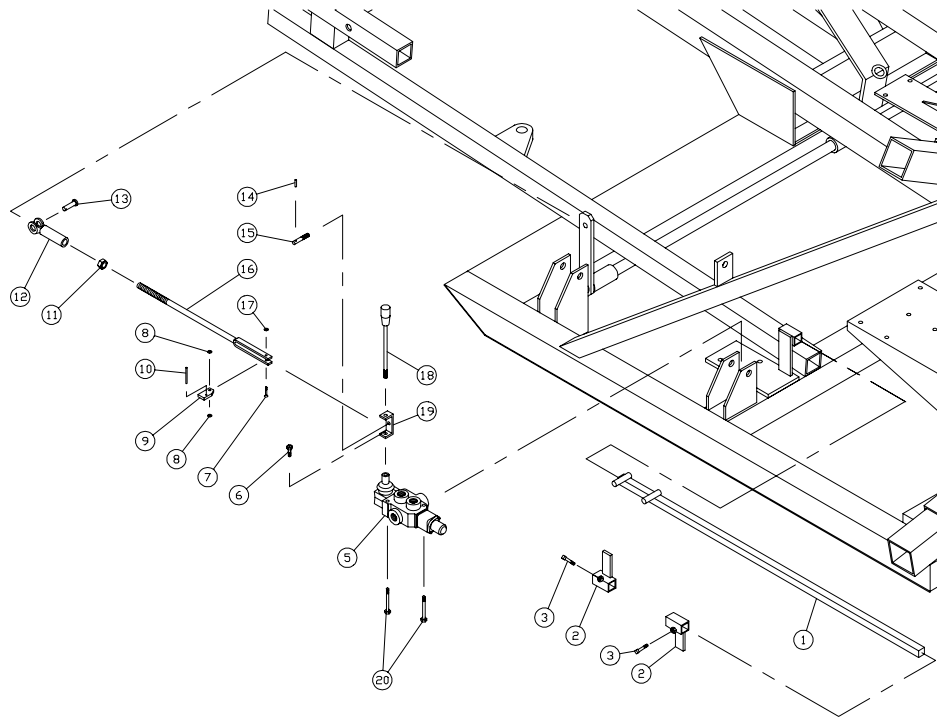

| REF. | PART #    | DESCRIPTION   | QTY  |      |
|------|-----------|---|------|------|
|      |           |   | 9000 | 9100 |
| 1    | 110-06321 | Rod (9000) .....  | 1    | -    |
| 1    | 110-06311 | Rod (9100) .....  | -    | 1    |
| 2    | 32141     | Stopper .....   | 2    | 2    |
| 3    | Std.      | Square head set screw 5/16" NC x 3/4" lg .....                | 2    | 2    |
| 5    | 32232     | 1 spool control valve (see details p. 34) .....               | 1    | 1    |
| 6    | Std.      | Bolt M8 x 1.25 x 16mm lg + lock washer .....                  | 1    | 1    |
| 7    | Std.      | Flat head screw 10-24 UNC x 1" lg + nylon locknut .....       | 1    | 1    |
| 8    | 32144     | Flat washer 3/16 (brass) .....                                | 2    | 2    |
| 9    | 32145     | Lever .....   | 1    | 1    |
| 10   | Std.      | Roll pin 5/32" X 1 1/4" lg .....                              | 1    | 1    |
| 11   | Std.      | Nut 1/2" NF .....   | 1    | 1    |
| 12   | 51435     | Clevis 1/2" NF .....  | 1    | 1    |
| 13   | 51436     | Pin 1/2" ø x 1 3/4" lg + cotter pin 1/8" x 3/4" lg .....      | 1    | 1    |
| 14   | Std.      | Roll pin 5/32" x 3/4" lg .....                                | 1    | 1    |
| 15   | 32146     | Valve actuator pin + 2 nut 5/16" NC + lock washer .....       | 1    | 1    |
| 16   | 32147     | Rod (9000) .....  | 1    | -    |
| 16   | 32148     | Rod (9100) .....  | -    | 1    |
| 17   | 32149     | Lock washer 3/16" .....                                       | 1    | 1    |
| 18   | 649-00009 | Spool handle + 2 nut M8 x 1.25 .....                          | 1    | 1    |
| 19   | 190-01651 | Spool handle support .....                                    | 1    | 1    |
| 20   | Std.      | Bolt 5/16" NC x 2 1/2" lg + nylon locknut & flat washer ..... | 2    | 2    |

8

# ARCH CYLINDER 9000

15022

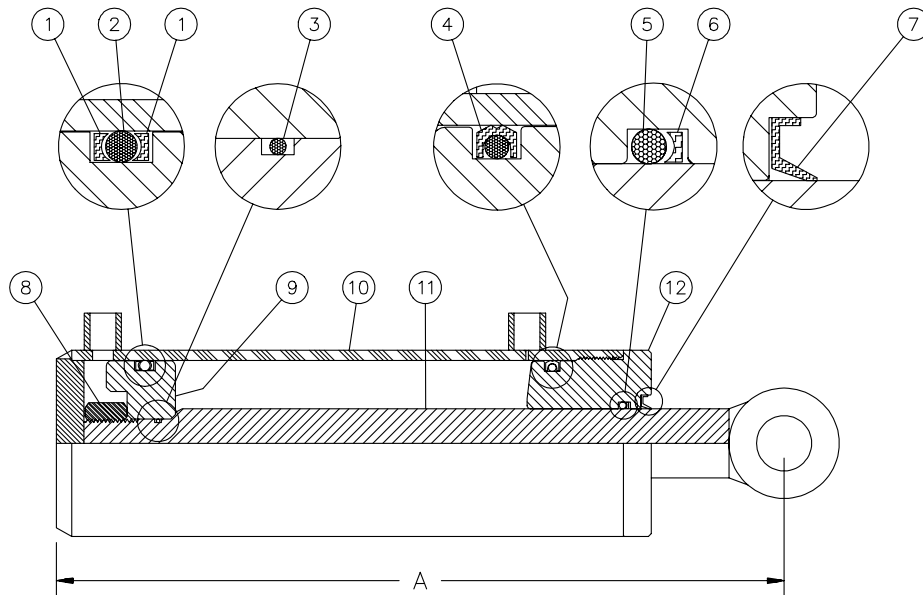

| <u>MODEL</u> | <u>LENGTH A</u> |
|--------------|-----------------|
| 30Z10        | 16"             |
| 30Z15        | 21"             |
| 30Z17        | 23"             |

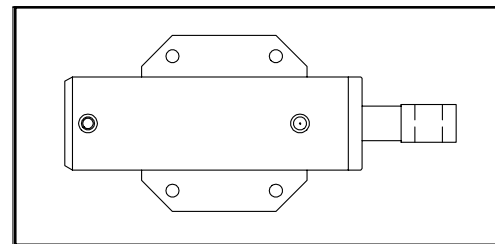

| REF. | PART #  | DESCRIPTION   | QTY CYLINDER # |       |       |
|------|---------|---|----------------|-------|-------|
|      |         |   | 30Z10          | 30Z15 | 30Z17 |
| 1    | BU-334  | Back-up ring 3/16" x 2 5/8" x 3" .....                            | 2              | 2     | 2     |
| 2    | OR-334  | O-ring 3/16" x 2 5/8" x 3" .....                                  | 2              | 2     | 2     |
| 3    | OR-018  | O-ring 1/16" x 3/4" x 7/8" .....                                  | 1              | 1     | 1     |
| 4    | PSP-334 | O-ring "heavy duty" 3/16" x 2 5/8" x 3" .....                     | 1              | 1     | 1     |
| 5    | OR-218  | O-ring 1/8" x 1 1/4" x 1 1/2" .....                               | 1              | 1     | 1     |
| 6    | BU-218  | Back-up ring 1/8" x 1 1/4" x 1 1/2" .....                         | 1              | 1     | 1     |
| 7    | CR12330 | Wiper 1/8" x 1 1/4" x 1 1/2" .....                                | 1              | 1     | 1     |
| 8    | Std.    | Nut 7/8" NF .....   | 1              | 1     | 1     |
| 9    | D-6000  | Piston 3" dia. ....   | 1              | 1     | 1     |
| 10   | D-6096  | Cylinder body 3" for 30Z10 .....                                  | 1              | -     | -     |
| 10   | D-6097  | Cylinder body 3" for 30Z15 .....                                  | -              | 1     | -     |
| 10   | D-6098  | Cylinder body 3" for 30Z17 .....                                  | -              | -     | 1     |
| 11   | D-6099  | Piston rod 1 1/4" for 30Z10 and 30H10 .....                       | 1              | -     | -     |
| 11   | D-6100  | Piston rod 1 1/4" for 30Z15 and 30H15 .....                       | -              | 1     | -     |
| 11   | D-6101  | Piston rod 1 1/4" for 30Z17 and 30H17 .....                       | -              | -     | 1     |
| 12   | D-6093  | Head 3" dia. ....   | 1              | 1     | 1     |
| NI*  | 32204   | Repair kit for cylinder 3" (includes # 1, 2, 3, 4, 5, 6, & 7) ... | 1              | 1     | 1     |

NI = Not illustrated



# ARCH CYLINDER 9100

15102

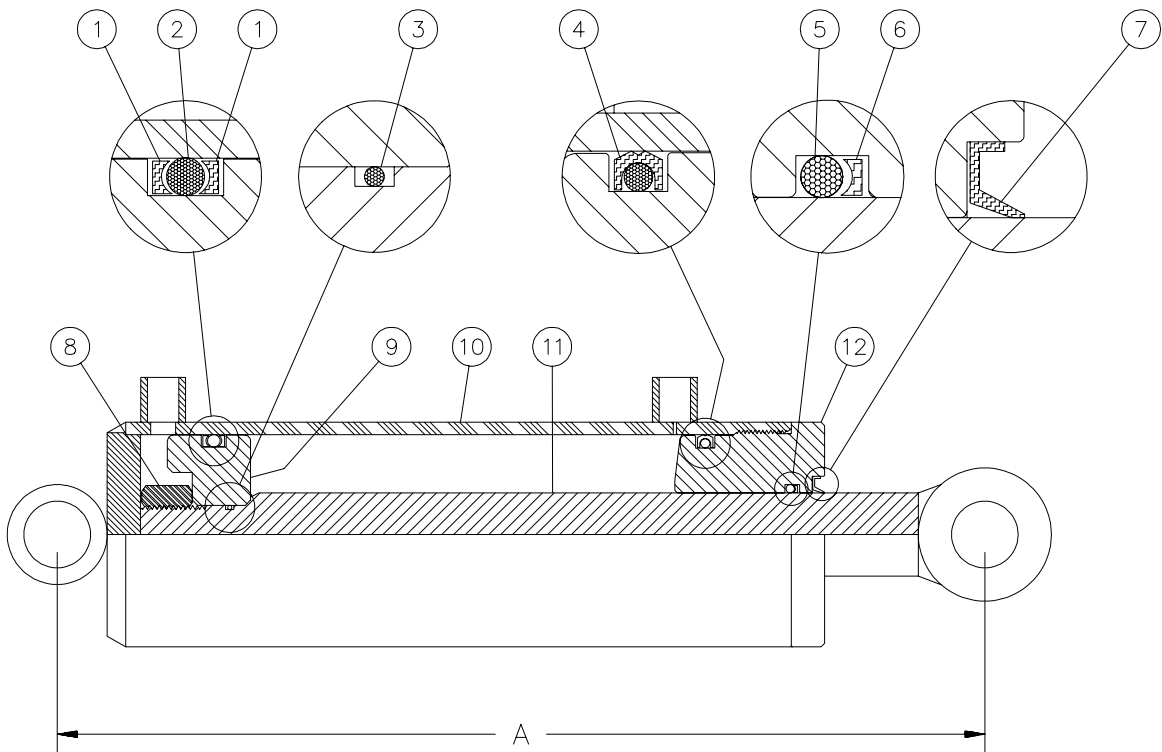

| <u>MODEL</u> | <u>LENGTH A</u>                  |
|--------------|----------------------------------|
| 30H10        | 16 <sup>3</sup> / <sub>4</sub> " |
| 30H17        | 23 <sup>3</sup> / <sub>4</sub> " |

| REF. | PART #  | DESCRIPTION   | QTY CYLINDER # |       |
|------|---------|---|----------------|-------|
|      |         |   | 30H10          | 30H17 |
| 1    | BU-334  | Back-up ring 3/16" x 2 5/8" x 3" .....                              | 2              | 2     |
| 2    | OR-334  | O-ring 3/16" x 2 5/8" x 3" .....                                    | 2              | 2     |
| 3    | OR-018  | O-ring 1/16" x 3/4" x 7/8" .....                                    | 1              | 1     |
| 4    | PSP-334 | O-ring "heavy duty" 3/16" x 2 5/8" x 3" .....                       | 1              | 1     |
| 5    | OR-218  | O-ring 1/8" x 1 1/4" x 1 1/2" .....                                 | 1              | 1     |
| 6    | BU-218  | Back-up ring 1/8" x 1 1/4" x 1 1/2" .....                           | 1              | 1     |
| 7    | CR12330 | Wiper 1/8" x 1 1/4" x 1 1/2" .....                                  | 1              | 1     |
| 8    | Std.    | Nut 7/8" NF .....   | 1              | 1     |
| 9    | D-6000  | Piston 3" dia. ....   | 1              | 1     |
| 10   | D-6168  | Cylinder body 3" for 30H10 .....                                    | 1              | -     |
| 10   | D-6170  | Cylinder body 3" for 30H17 .....                                    | -              | 1     |
| 11   | D-6099  | Piston rod 1 1/4" for 30Z10 and 30H10 .....                         | 1              | -     |
| 11   | D-6101  | Piston rod 1 1/4" for 30Z17 and 30H17 .....                         | -              | 1     |
| 12   | D-6093  | Head 3" dia. ....   | 1              | 1     |
| NI*  | 32204   | Repair kit for cylinder 3" (includes # 1, 2, 3, 4, 5, 6, & 7) ..... | 1              | 1     |

NI = Not illustrated

8

# PUSHER CYLINDER # 20I72

15094

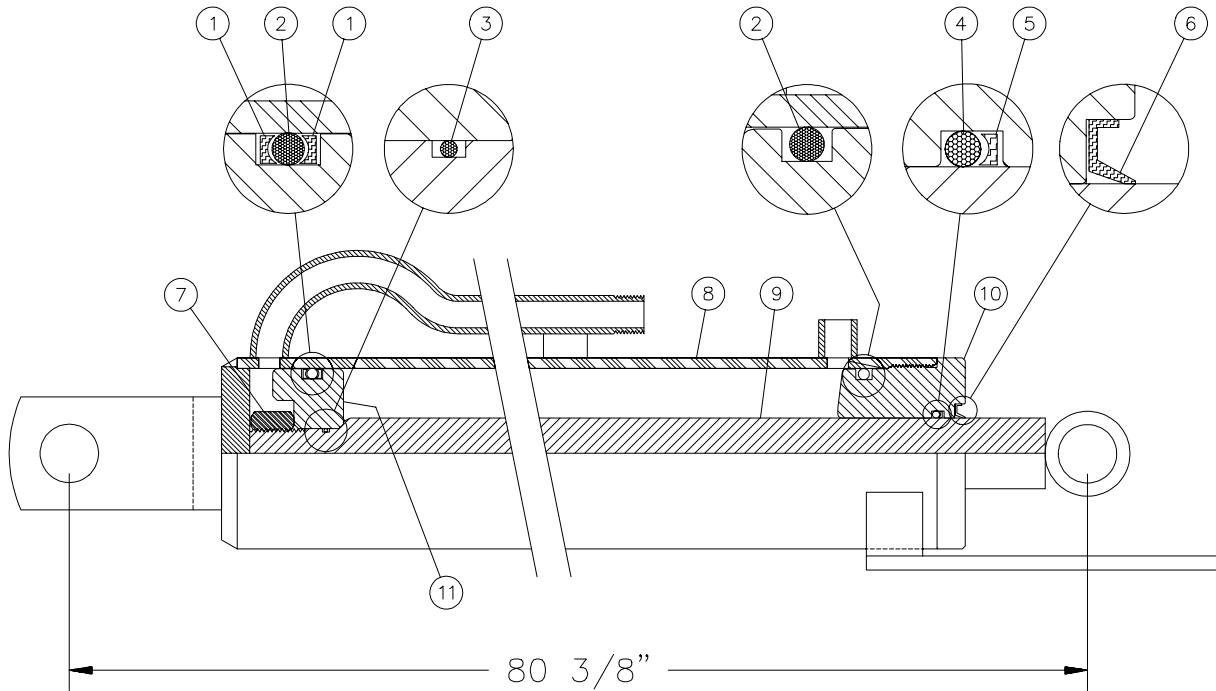

| REF. | PART #  | DESCRIPTION  | QTY   |
|------|---------|--|-------|
|      |         |  | 20172 |
| 1    | BU-326  | Back-up ring 3/16" x 1 5/8" x 2" .....                           | 2     |
| 2    | OR-326  | O-ring 3/16" x 1 5/8" x 2" .....                                 | 2     |
| 3    | OR-016  | O-ring 1/16" x 5/8" x 3/4" .....                                 | 1     |
| 4    | OR-218  | O-ring 1/8" x 1 1/4" x 1 1/2" .....                              | 1     |
| 5    | BU-218  | Back-up ring 1/8" x 1 1/4" x 1 1/2" .....                        | 1     |
| 6    | CR12330 | Wiper 1/8" x 1 1/4" x 1 1/2" .....                               | 1     |
| 7    | Std.    | Nut 3/4" NF .....  | 1     |
| 8    | D-6179  | Cylinder body 2" ø .....   | 1     |
| 9    | D-6172  | Piston rod 1 1/4" ø for 20G72 & 20I72 .....                      | 1     |
| 10   | D-6032  | Head 2" ø .....  | 1     |
| 11   | D-6020  | Piston 2" ø .....  | 1     |
| NI*  | 32203   | Repair kit for cylinder 2" (includes # 1, 2, 3, 4, 5, & 6) ..... | 1     |

NI = Not illustrated

8

# CYLINDER 25TR04 & 25TR08

170-01811

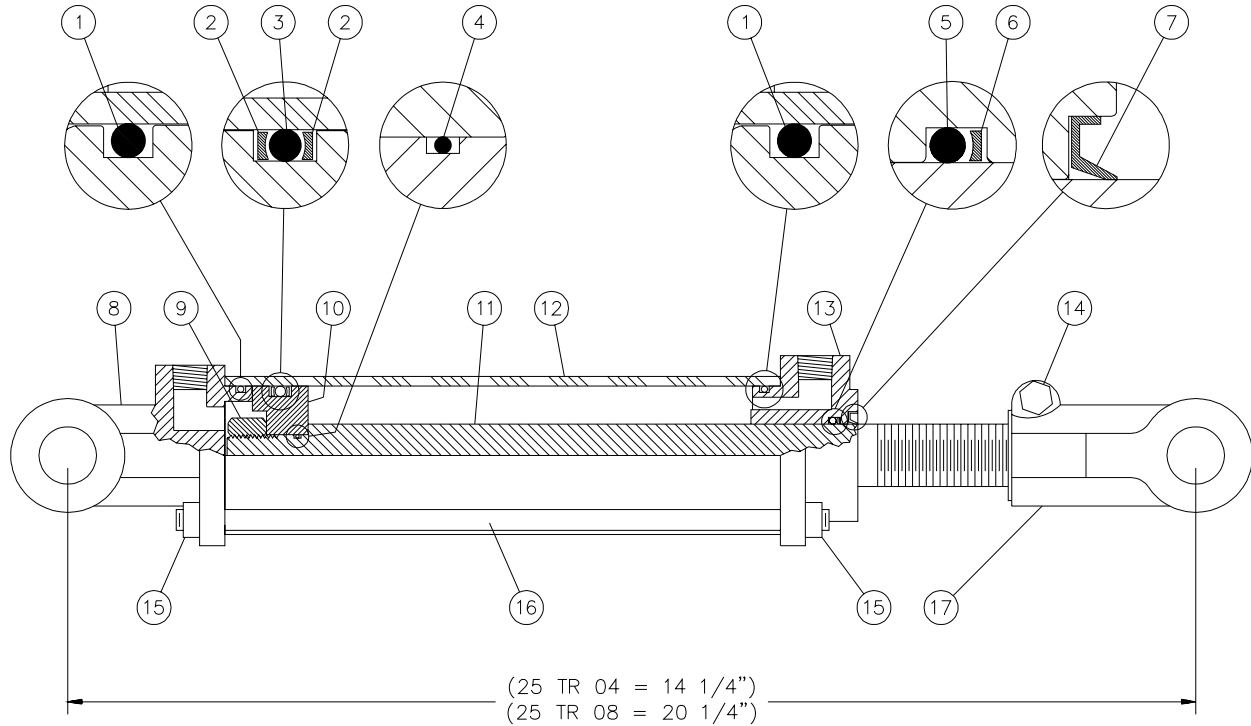

| REF. | PART #      | DESCRIPTION   | QTY    |        |
|------|-------------|---|--------|--------|
|      |             |   | 25TR04 | 25TR08 |
| 1    | Voir RK25TR | O-ring 1/8" x 2 1/4" x 2 1/2" .....                                     | 2      | 2      |
| 2    | Voir RK25TR | Back-up 2 1/2" o.d. x 1/8" ø .....                                      | 2      | 2      |
| 3    | Voir RK25TR | O-ring 3/16" x 2 1/8" x 2 1/2" .....                                    | 1      | 1      |
| 4    | Voir RK25TR | O-ring 1/16" x 5/8" x 3/4" .....  | 1      | 1      |
| 5    | Voir RK25TR | O-ring 1/8" x 1 1/8" x 1 3/8" .....                                     | 1      | 1      |
| 6    | Voir RK25TR | Back-up 1 3/8" o.d. x 1/8" ø .....                                      | 1      | 1      |
| 7    | Voir RK25TR | Wiper 1 1/8" i.d. x 1 5/8" o.d. ....                                    | 1      | 1      |
| 8    | 492401      | Yoke (for 2 1/2" tube) .....  | 1      | 1      |
| 9    | Std.        | Nut 3/4" NF .....   | 1      | 1      |
| 10   | 4924-31     | Piston 2 1/2" ø .....   | 1      | 1      |
| 11   | 491980-04   | Piston rod 1 1/8" .....   | 1      | -      |
| 11   | 492028      | Piston rod 1 1/8" .....   | -      | 1      |
| 12   | 491668-04   | Cylinder body 2 1/2" ø .....  | 1      | -      |
| 12   | 491668      | Cylinder body 2 1/2" ø .....  | -      | 1      |
| 13   | 492421      | Head (for 2 1/2" tube) .....  | 1      | 1      |
| 14   | Std.        | Bolt 3/8" NC x 2 1/4" + nut .....                                       | 1      | 1      |
| 15   | Std.        | Nut 3/8" NC .....   | 8      | 8      |
| 16   | Std.        | Threaded rod 3/8" NC 8 3/8" lg .....                                    | 4      | -      |
| 16   | Std.        | Threaded rod 3/8" NC 12 3/8" lg .....                                   | -      | 4      |
| 17   | 458599      | Yoke (for 1 1/8" rod) .....   | 1      | 1      |
| NI*  | 8183        | Pin 1" ø + cotter pin .....   | 2      | 2      |
| NI*  | RK25TR      | Repair kit for cylinder 2 1/2" (includes # 1, 2, 3, 4, 5, 6, & 7) ..... | 1      | 1      |

\*NI = NON ILLUSTRÉ





# 6 SPOOL CONTROL VALVE # 32111

170-01841

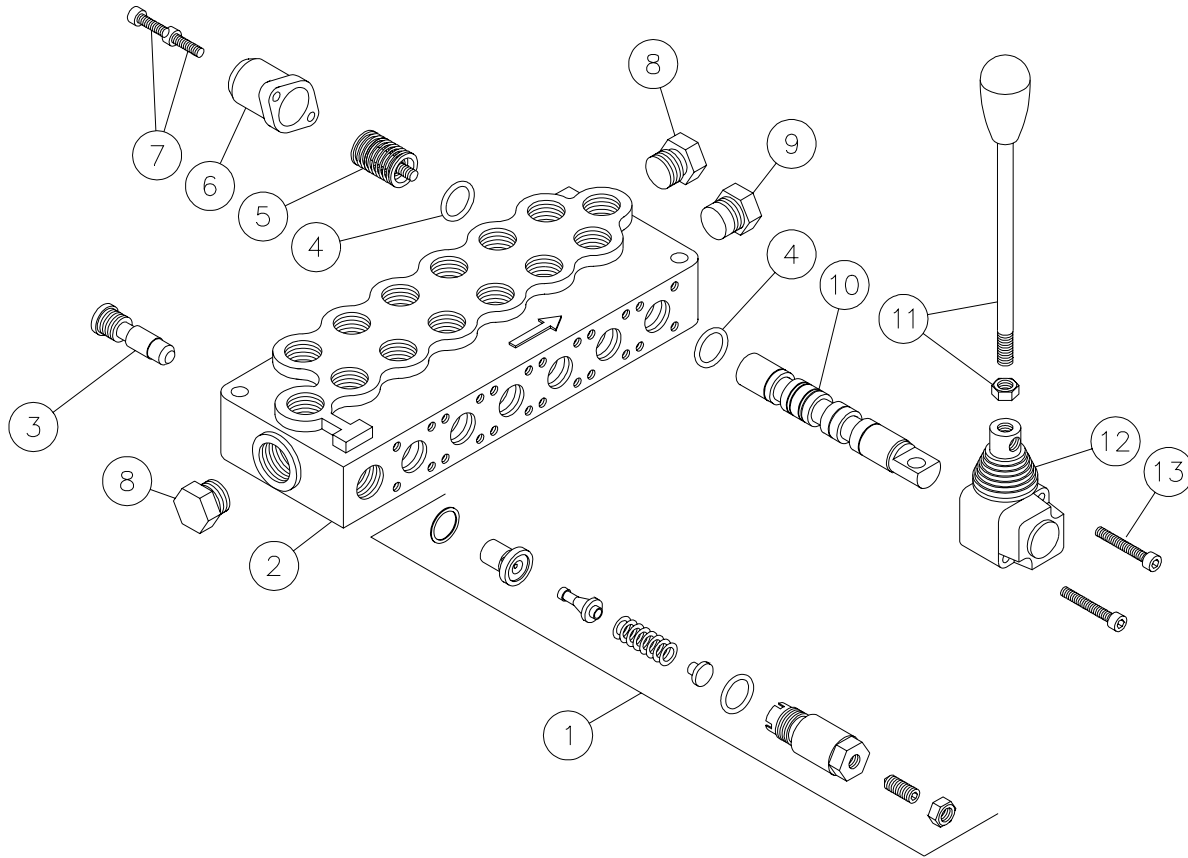

| REF. | PART # | CODE #      | DESCRIPTION              | QTY |
|------|--------|-------------|--------------------------|-----|
| 1    | 32275  | 5KIT105413  | Relief valve .....       | 1   |
| 2    | 32168  | 3CO1357000  | Valve housing .....      | 1   |
| 3    | 32076  | XKIT005000  | Kit VR5 .....            | 1   |
| 4    | 32077  | 4GUA115926  | O-ring .....             | 12  |
| 5    | 32078  | XV08105000  | Spring .....             | 6   |
| 6    | 32079  | 3CAP210370  | Endcap .....             | 6   |
| 7    | 32080  | 4VIT605014  | Screw M5 x 14 .....      | 12  |
| 8    | 32081  | 3XTAP822150 | Plug SAE8 .....          | 2   |
| 9    | 32082  | 3XTAP623170 | Plug (open center) ..... | 1   |
| 10   | 32085  | 3CU1210130  | Valve spool .....        | 6   |
| 11   | 32274  | - - - - -   | Lever .....              | 6   |
| 12   | 32086  | 3XLEV105000 | Lever endcap .....       | 6   |
| 13   | 32087  | 4VIT605035  | Screw M5 x 35 .....      | 12  |

8

# 1 SPOOL CONTROL VALVE # 32232 (SD4 modified)

170-01851

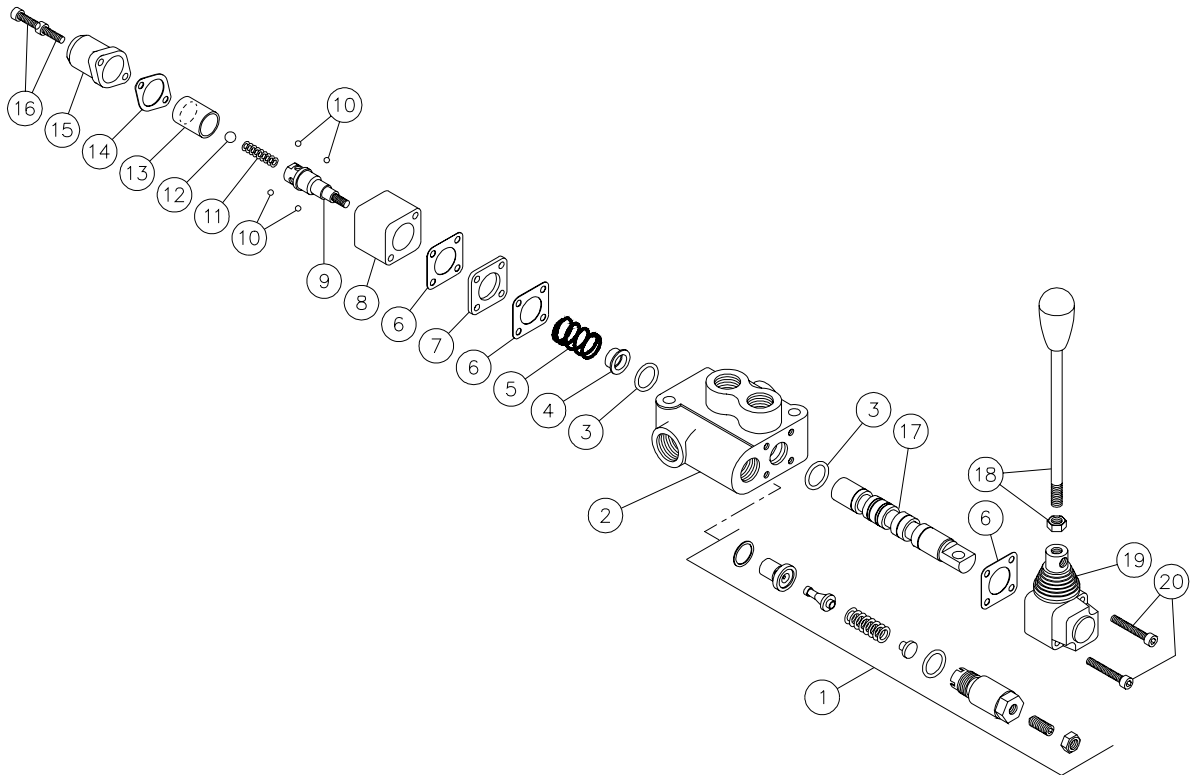

| REF. | PART # | CODE #      | DESCRIPTION                           | QTY |
|------|--------|-------------|---------------------------------------|-----|
| 1    | 32275  | 5KIT105413  | Relief valve .....                    | 1   |
| 2    | 32233  | -----       | Valve housing .....                   | 1   |
| 3    | 32077  | 4GUA115926  | O-ring .....                          | 2   |
| 4    | 32191  | 3BOC119130  | Ring .....                            | 1   |
| 5    | 32234  | -----       | Spring .....                          | 1   |
| 6    | 32276  | 3GUA136031  | Square gasket .....                   | 3   |
| 7    | 32192  | 3DIS121035  | Aluminium spacer .....                | 1   |
| 8    | 32187  | 3CAP220331  | Cap .....                             | 1   |
| 9    | 32189  | 3PER115571  | Pin .....                             | 1   |
| 10   | 32182  | 4SFE204762  | Ball 4.762 .....                      | 4   |
| 11   | 32188  | 3MOL208280  | Spring .....                          | 1   |
| 12   | 32183  | 4SFE209525  | Ball 9.525 .....                      | 1   |
| 13   | 32186  | 3BUS221271  | Ring .....                            | 1   |
| 14   | 32277  | 3GUA136032  | Oval gasket .....                     | 1   |
| 15   | 32079  | 3CAP210370  | Endcap .....                          | 1   |
| 16   | 32184  | 4VIT605050  | Bolt M5 x 50 .....                    | 2   |
| 17   | 32193  | 3CU1110120  | Spool .....                           | 1   |
| 18   | 32274  | -----       | Lever .....                           | 1   |
| 19   | 32086  | 3XLEV105000 | Lever endcap .....                    | 1   |
| 20   | 32087  | 4VIT605035  | Bolt M5 x 35 .....                    | 2   |
| NI*  | 21CSD4 |             | Repair kit (includes # 3 to 16) ..... | 1   |

Some parts might not be available separately

\*NI = Not illustrated

8

# ENGINE ASSEMBLY WITH PUMP

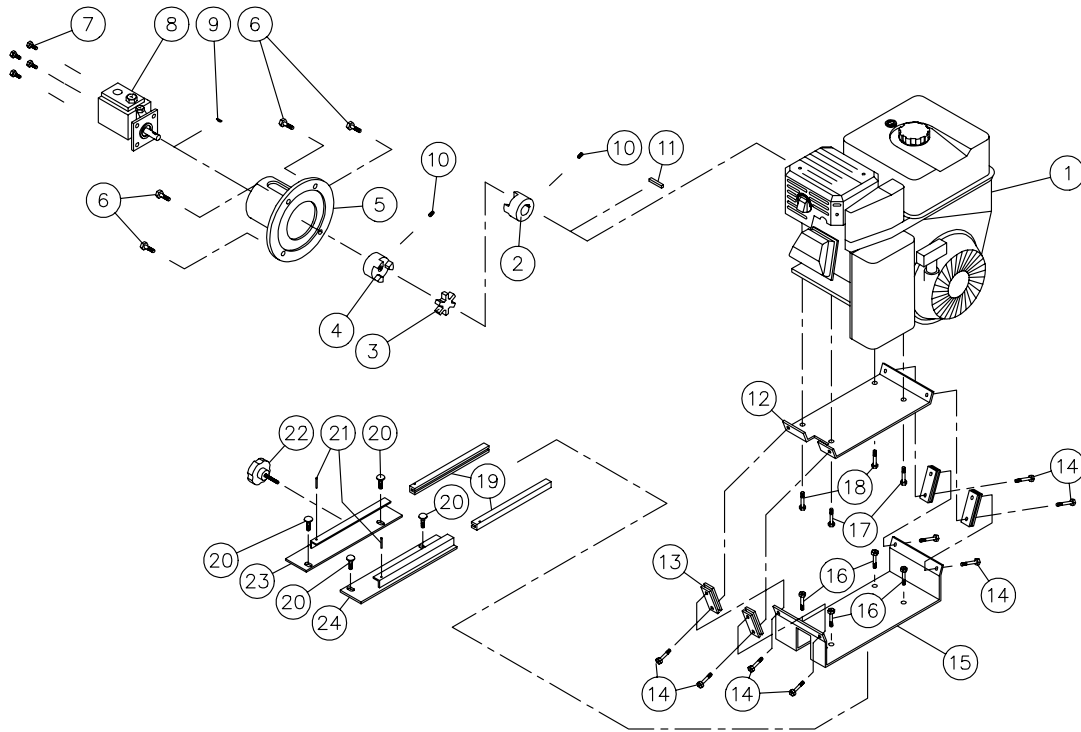

| REF. | PART #    | DESCRIPTION  | QTY AGRIPAC® LASTIC TUBER™ |      |
|------|-----------|--|----------------------------|------|
|      |           |  | 9000                       | 9100 |
| 1    | 32230     | Engine HONDA 9HP .....                                     | 1                          | 1    |
| 1    | 32257     | Engine HONDA 9HP with electric starter .....               | opt.                       | opt. |
| 2    | 32133     | Flexible coupling 1" ø .....                               | 1                          | 1    |
| 3    | 32134     | Flexible coupling .....                                    | 1                          | 1    |
| 4    | 32135     | Flexible coupling ½" ø .....                               | 1                          | 1    |
| 5    | 32136     | Mounting flange .....                                      | 1                          | 1    |
| 6    | Std.      | Bolt 3/8" NC x 1" lg + lock washer .....                   | 4                          | 4    |
| 7    | Std.      | Bolt 5/16" NC x 3/4" lg + lock washer .....                | 4                          | 4    |
| 8    | 32002     | Pump .....   | 1                          | 1    |
| 9    | Std.      | Woodruff key 1/8" .....                                    | 1                          | 1    |
| 10   | Std.      | Socket set screw 5/16" NC x 1/2" .....                     | 2                          | 2    |
| 11   | Std.      | Square key 1/4" x 1 1/2" lg .....                          | 1                          | 1    |
| 12   | 32194     | Upper motor mounting plate .....                           | 1                          | 1    |
| 13   | 190-03311 | Anti-vibration supports .....                              | 4                          | 4    |
| 14   | Std.      | Bolt 5/16" NC x 1" lg + nylon locknut & flat washer .....  | 8                          | 8    |
| 15   | 32196     | Lower motor mounting plate .....                           | 1                          | 1    |
| 16   | Std.      | Bolt 3/8" NC x 1" lg + nylon locknut .....                 | 4                          | 0    |
| 17   | Std.      | Bolt 3/8" NC x 1 ¾" lg + nylon locknut .....               | 2                          | 2    |
| 18   | Std.      | Bolt 3/8" NC x 1 ¾" lg + nylon locknut & flat washer ..... | 2                          | 2    |
| 19   | 190-00202 | Slide engine mount .....                                   | 0                          | 2    |
| 20   | Std.      | Carriage bolt 3/8" NC x 1" lg + nylon locknut .....        | 0                          | 4    |
| 21   | Std.      | Roll pin 1/8" x 1" lg .....                                | 0                          | 2    |
| 22   | 110-00591 | Slide handle .....   | 0                          | 1    |
| 23   | 110-00582 | Left mount for slide .....                                 | 0                          | 1    |
| 24   | 110-00572 | Right mount for slide .....                                | 0                          | 1    |

# HUB H1000

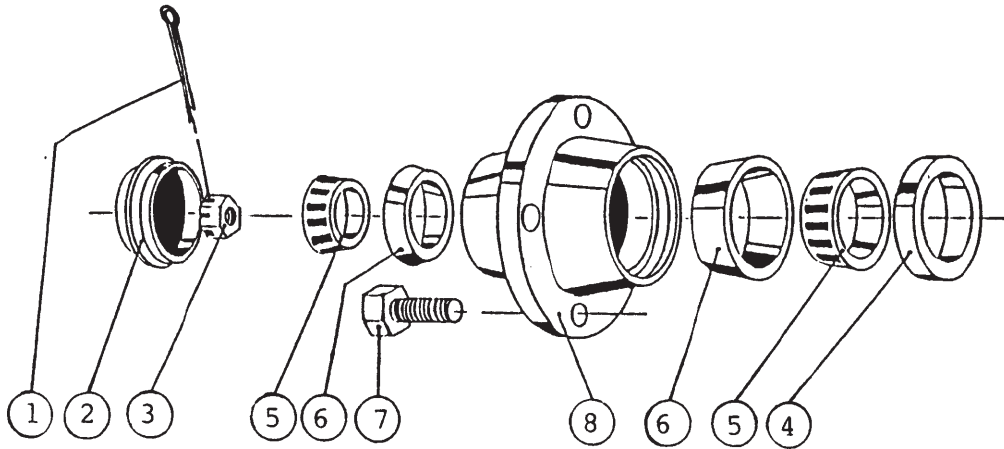

## FRONT HUB FOR 9000

| REF. | PART # | DESCRIPTION                                  | QTY |
|------|--------|--|-----|
| 1    | Std.   | Cotter pin 5/32" x 1 3/4" .....              | 1   |
| 2    | 53019  | Dust cap 1.973 ø. ....                       | 1   |
| 3    | 53020  | Castle nut 1" NF .....                       | 1   |
| 4    | 53021  | Oil seal no. CR523696 .....                  | 1   |
| 5    | 53022  | Roller bearing Timken: cone no. L44643 ..... | 2   |
| 6    | 53023  | Roller bearing Timken: cup no. L44610 .....  | 2   |
| 7    | 53024  | Rim screw 1/2" .....                         | 4   |
| 8    | 53025  | Hub only H1000 .....                         | 1   |

8

# HUB H2500

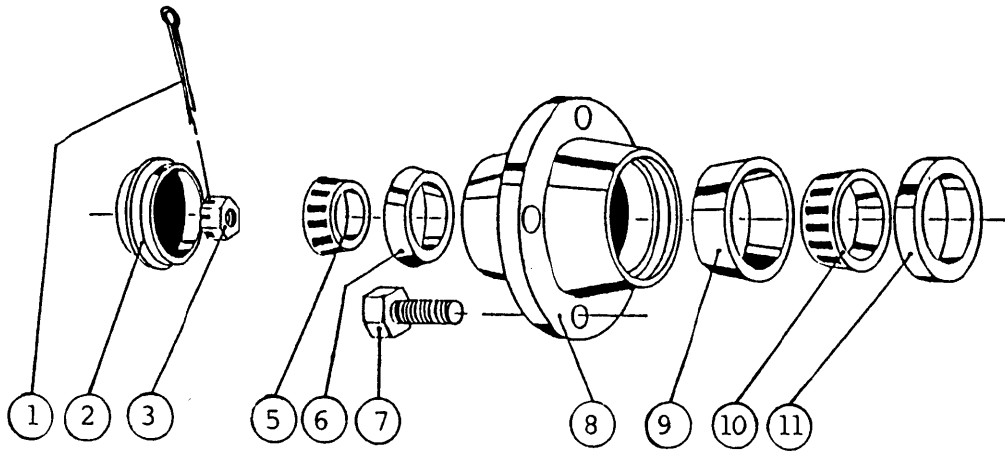

## REAR HUB FOR 9000 & FRONT AND REAR HUB FOR 9100

| REF. | PART # | DESCRIPTION                                   | QTY |
|------|--------|---|-----|
| 1    | Std.   | Cotter pin 5/32" x 1 3/4" .....               | 1   |
| 2    | 53019  | Dust cap D-1000 1.973" ø .....                | 1   |
| 3    | 51529  | Castle nut 1" NF x 9/16" thick .....          | 1   |
| 5    | 53058  | Roller bearing Timken: cone no. L44649 .....  | 1   |
| 6    | 53023  | Roller bearing Timken: cup no. L44610 .....   | 1   |
| 7    | 53024  | Rim screw 1/2" .....                          | 5   |
| 8    | 53059  | Hub only H2500 .....                          | 1   |
| 9    | 51415  | Roller bearing Timken: cup no. LM48510 .....  | 1   |
| 10   | 51416  | Roller bearing Timken: cone no. LM48548 ..... | 1   |
| 11   | 51535  | Oil seal no. CR17415 .....                    | 1   |



# HYDRAULIC SYSTEM

170-01793

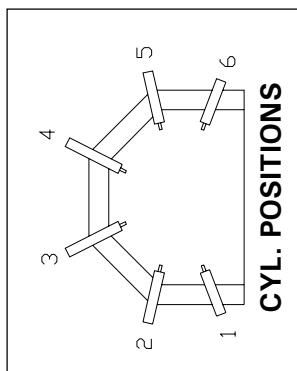
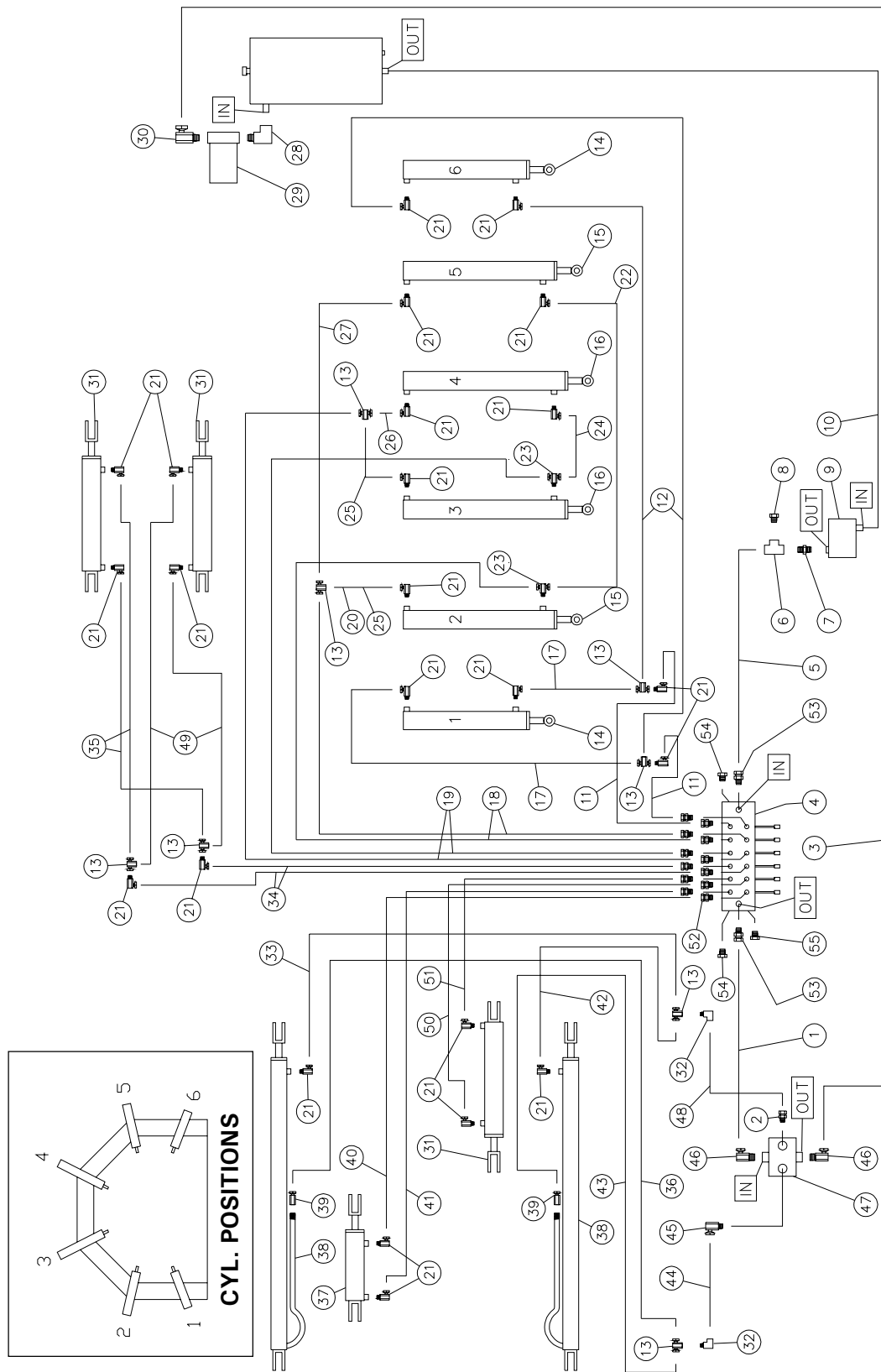

## HYDRAULIC SYSTEM (cont'd)

| REF. | PART #    | DESCRIPTION   | QTY  |      |
|------|-----------|---|------|------|
|      |           |   | 9000 | 9100 |
| 1    | 190-01621 | Hose ½" x 90" lg + 2 fittings 8U108 .....                     | 1    | 1    |
| 2    | Std.      | Fitting 9315 8 x 6 .....                                      | 15   | 15   |
| 3    | D-18089   | Hose ½" x 140" lg + 2 fittings 8U108 .....                    | 1    | 1    |
| 4    | 32111     | 6 spool control valve (see details page 33) .....             | 1    | 1    |
| 5    | D-8668    | Hose ½" x 38" lg + 2 fittings 8U108 .....                     | 1    | 1    |
| 6    | Std.      | "T" ½" C3709 x 8 .....  | 1    | 1    |
| 7    | Std.      | Straight female pipe to male pipe ½" C3069 x 8 .....          | 1    | 1    |
| 8    | Std.      | Plug ½" C3159 x 8 .....                                       | 1    | 1    |
| 9    | 32002     | Two stages 4/11 hydraulic pump .....                          | 1    | 1    |
| 10   | D-8727    | Low pressure hose 1" x 116½" lg .....                         | 1    | -    |
| 10   | D-18090   | Low pressure hose 1" x 123" lg .....                          | -    | 1    |
| 11   | D-18092   | Hose 3/8" x 48" lg + 2 fittings 6U106 .....                   | 2    | 2    |
| 12   | D-8678    | Hose 3/8" x 94" lg + 2 fittings 6U106 .....                   | 2    | -    |
| 12   | D-18093   | Hose 3/8" x 112" lg + 2 fittings 6U106 .....                  | -    | 2    |
| 13   | Std.      | "T" swivel 3/8" 15856 x 6 .....                               | 8    | 8    |
| 14   | 30Z10     | Cylinder 3" x 10" stroke (see details page 29) .....          | 2    | -    |
| 14   | 30H10     | Cylinder 3" x 10" stroke (see details page 30) .....          | -    | 2    |
| 15   | 30Z15     | Cylinder 3" x 15" stroke (see details page 29) .....          | 2    | -    |
| 15   | 30H17     | Cylinder 3" x 17" stroke (see details page 30) .....          | -    | 2    |
| 16   | 30Z17     | Cylinder 3" x 17" stroke (see details page 29) .....          | 2    | -    |
| 16   | 30H17     | Cylinder 3" x 17" stroke (see details page 30) .....          | -    | 2    |
| 17   | D-18097   | Hose 3/8" x 29" lg + 2 fittings 6U106 .....                   | 2    | 2    |
| 18   | D-8675    | Hose 3/8" x 31" lg + 2 fittings 6U106 .....                   | 2    | -    |
| 18   | 190-00001 | Hose 3/8" x 48" lg + 2 fittings 6U106 .....                   | -    | 2    |
| 19   | D-8676    | Hose 3/8" x 58" lg + 2 fittings 6U106 .....                   | 2    | -    |
| 19   | D-8760    | Hose 3/8" x 64" lg + 2 fittings 6U106 .....                   | -    | 2    |
| 20   | D-18096   | Hose 3/8" x 11" lg + 2 fittings 6U106 .....                   | 1    | -    |
| 21   | Std.      | Fitting 9405 6x6 .....  | 24   | 24   |
| 22   | 190-03131 | Hose 3/8" x 154" lg + 2 fittings 6U106 .....                  | -    | 1    |
| 23   | Std.      | "T" swivel 3/8" 15855 x 6 .....                               | 2    | 2    |
| 24   | D-8673    | Hose 3/8" x 43 ½" lg + 2 fittings 6U106 .....                 | 1    | -    |
| 24   | D-18098   | Hose 3/8" x 49" lg + 2 fittings 6U106 .....                   | -    | 1    |
| 25   | D-18099   | Hose 3/8" x 12 ¾" lg + 2 fittings 6U106 .....                 | 1    | 2    |
| 26   | D-18100   | Hose 3/8" x 52" lg + 2 fittings 6U106 .....                   | 1    | 1    |
| 27   | D-8674    | Hose 3/8" x 122 3/4" lg + 2 fittings 6U106 .....              | 2    | -    |
| 27   | D-18101   | Hose 3/8" x 148" lg + 2 fittings 6U106 .....                  | -    | 1    |
| 28   | Std.      | Street elbow 3/4" 90° C3409 x 12 .....                        | 1    | 1    |
| 29   |           | Paper filter 32007 + hydraulic oil filter adaptor 32031 ..... | 1    | 1    |
| 30   | Std.      | Fitting 9205 8x12 .....                                       | 1    | 1    |
| 31   | 25TR08    | Cylinder 2 ½" x 8" (see details page 32) .....                | 3    | 3    |
| 32   | Std.      | Street elbow 3/8" 90° C3409 x 6 .....                         | 2    | 2    |
| 33   | 190-00611 | Hose 3/8" x 52" lg + 2 fittings 6U106 .....                   | 1    | 1    |
| 34   | 190-03061 | Hose 3/8" x 54" lg + 2 fittings 6U106 .....                   | 2    | 2    |
| 35   | 190-03081 | Hose 3/8" x 107" lg + 2 fittings 6U106 .....                  | 2    | -    |
| 35   | 190-03091 | Hose 3/8" x 115" lg + 2 fittings 6U106 .....                  | -    | 2    |
| 36   | D-18103   | Hose 3/8" x 60" lg + 2 fittings 6U106 .....                   | 1    | -    |
| 36   | D-18104   | Hose 3/8" x 66" lg + 2 fittings 6U106 .....                   | -    | 1    |
| 37   | 25TR04    | Cylinder 2 ½" x 4" (see details page 32) .....                | 1    | 1    |
| 38   | 20I72     | Cylinder 2" x 72" stroke (see details page 31) .....          | 2    | 2    |
| 39   | Std.      | Fitting 9255 6x6 .....  | 2    | 2    |

## HYDRAULIC SYSTEM (cont'd)

| REF. | PART #    | DESCRIPTION   | QTY  |      |    |
|------|-----------|---|------|------|----|
|      |           |   | 9000 | 9100 |    |
| 40   | D-8964    | Hose 3/8" x 158" lg + 2 fittings 6U106 .....                      | 1    | ...  | -  |
| 40   | D-18105   | Hose 3/8" x 168" lg + 2 fittings 6U106 .....                      | -    | ...  | 1  |
| 41   | D-8965    | Hose 3/8" x 164" lg + 2 fittings 6U106 .....                      | 1    | ...  | -  |
| 41   | D-18106   | Hose 3/8" x 170" lg + 2 fittings 6U106 .....                      | -    | ...  | 1  |
| 42   | D-18107   | Hose 3/8" x 63" lg + 2 fittings 6U106 .....                       | 1    | ...  | 1  |
| 43   | D-18108   | Hose 3/8" x 68" lg + 2 fittings 6U106 .....                       | 1    | ...  | 1  |
| 44   | D-8986    | Hose 1/2" x 53" lg + 2 fittings 8U106 .....                       | 1    | ...  | 1  |
| 45   | Std.      | Fitting 9515 8x6 .....  | 1    | ...  | 1  |
| 46   | Std.      | Fitting 9515 8x8 .....  | 2    | ...  | 2  |
| 47   | 32232     | 1 spool valve (see details page 34) .....                         | 1    | ...  | 1  |
| 48   | 190-02021 | Hose 1/2" x 53" lg + 1 fittings 8U106 + 1 fitting 22591-8-8 ..... | 1    | ...  | -  |
| 48   | 190-02011 | Hose 1/2" x 57" lg + 1 fittings 8U106 + 1 fitting 22591-8-8 ..... | -    | ...  | 1  |
| 49   | 190-03071 | Hose 3/8" x 34" lg + 2 fittings 6U106 .....                       | 2    | ...  | 2  |
| 50   | D-8985    | Hose 3/8" x 138" lg + 2 fittings 6U106 .....                      | 1    | ...  | 1  |
| 51   | D-18085   | Hose 3/8" x 122" lg + 2 fittings 6U106 .....                      | 1    | ...  | 1  |
| 52   | Std.      | Fitting 9315 6x6 .....  | 12   | ...  | 12 |
| 53   | Std.      | Fitting 9315 8x8 .....  | 2    | ...  | 2  |
| 54   | Std.      | Plug 7238x8 .....   | 2    | ...  | 2  |
| 55   | Std.      | Plug M20x1.5 + o-ring (TN185G-20M) .....                          | 1    | ...  | 1  |



# ELECTRIC CIRCUIT

## WORKING LIGHTS

170-00381

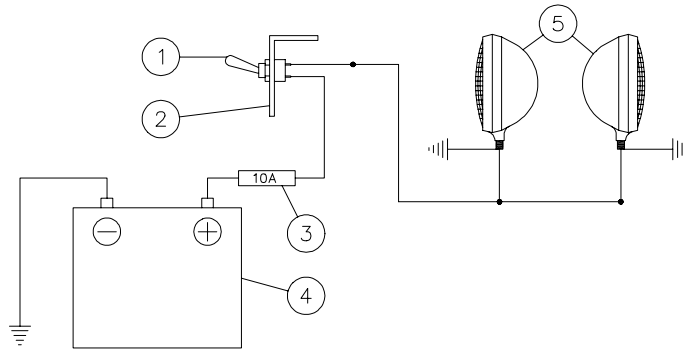

| REF. | PART #    | DESCRIPTION            | QTY |
|------|-----------|------------------------|-----|
| 1    | 32237     | Switch ON-OFF .....    | 1   |
| 2    | 130-04481 | Switch support .....   | 1   |
| 3    | Std.      | Fuse 10A .....         | 1   |
| 4    | 32283     | Battery 12V-540A ..... | 1   |
| 5    | 110-04771 | Working lights .....   | 2   |

## ROAD LIGHTS

170-00381

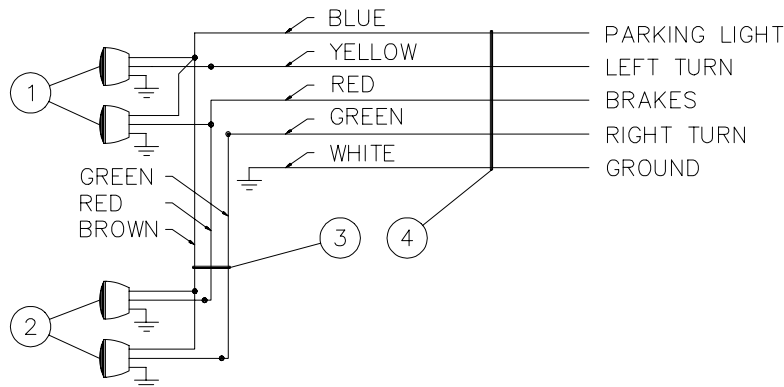

| REF. | PART #    | DESCRIPTION                                    | QTY |
|------|-----------|--|-----|
| 1    | 32228     | Left red flashers with license light .....     | 2   |
| 2    | 32229     | Right red flashers .....                       | 2   |
| 3    | 110-03601 | 3 conductors cable with terminal 204" lg ..... | 1   |
| 4    | 110-03591 | 5 conductors cable with terminal 288" lg ..... | 1   |



# TRACTION MECHANISM

170-01861

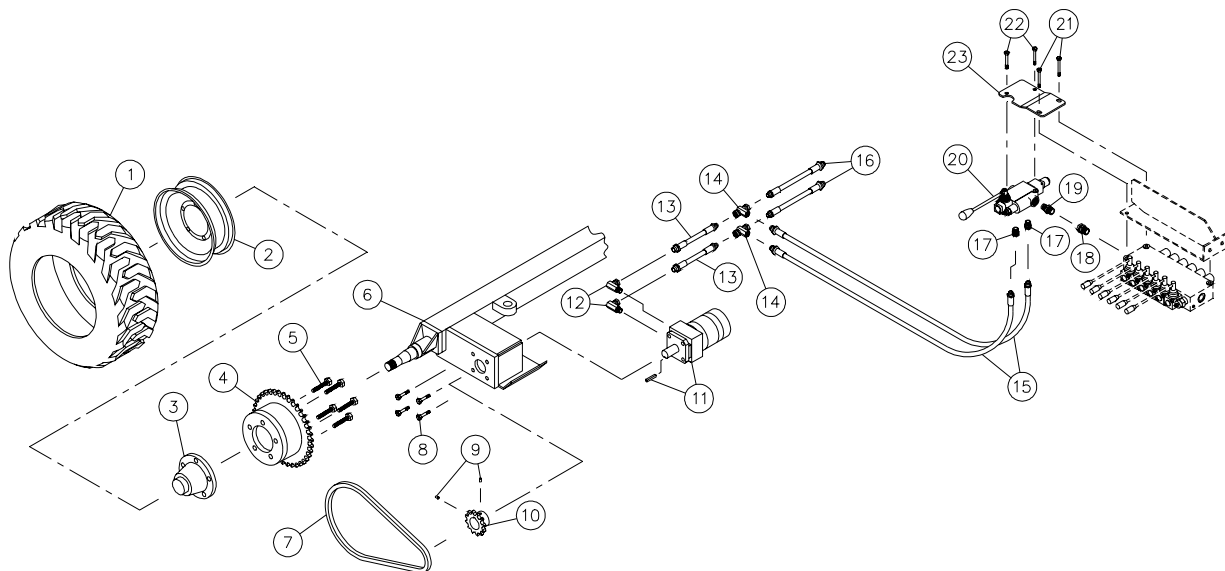

| REF. | PART #     | DESCRIPTION  | QTY  |      |
|------|------------|--|------|------|
|      |            |  | 9000 | 9100 |
| 1    | PNA238512  | Traction tire .....  | 2    | 2    |
| 2    | R-1275     | Rim 12 x 7 - 5 bolts .....                                 | 2    | 2    |
| 3    | 190-01281  | Hub H-2500 modified .....                                  | 2    | 2    |
| 4    | 110-08841  | Sprocket 60A38 .....                                       | 2    | 2    |
| 5    | 110-10991  | Bolt 1/2" NF x 2 3/4" lg + nut .....                       | 10   | 10   |
| 6    | 110-11791  | Front axle for 9000 .....                                  | 1    | -    |
| 6    | 110-11801  | Front axle for 9100 .....                                  | -    | 1    |
| 7    | 190-02881  | Chain #60 x 36" lg .....                                   | 2    | 2    |
| 8    | Std.       | Bolt 3/8" NC x 1" lg + lockwasher .....                    | 8    | 8    |
| 9    | Std.       | Hexagonal socket set screw 5/16" NC x 1/2" lg .....        | 4    | 4    |
| 10   | 110-10981  | Sprocket 60B14 .....                                       | 1    | 1    |
| 11   | DH315      | Hydraulic motor DH315 + key (see details p. 44) .....      | 2    | 2    |
| 12   | 9405x6x8   | Fitting 90 deg. (swivel) .....                             | 2    | 2    |
| 13   | Std.       | Hose 3/8" + 2 fittings 6U-106 .....                        | 2    | 2    |
| 14   | 5856x6x6x6 | "T" (swivel) .....   | 2    | 2    |
| 15   | Std.       | Hose 3/8" + 2 fittings 6U-106 .....                        | 2    | 2    |
| 16   | Std.       | Hose 3/8" + 2 fittings 6U-106 .....                        | 2    | 2    |
| 17   | 9315x8x6   | Straight fitting (swivel) .....                            | 2    | 2    |
| 18   | 9315x8x8   | Straight fitting (swivel) .....                            | 1    | 1    |
| 19   | 6401x8x8   | Straight fitting .....                                     | 1    | 1    |
| 20   | 640-10004  | 1 spool valve SD-4 (open center) (see details p. 43) ..... | 1    | 1    |
| 21   | Std.       | Bolt 5/16" NC x 2 3/4" lg + nylon locknut .....            | 2    | 2    |
| 22   | Sts.       | Bolt 5/16" NC x 2 1/2" lg + nylon locknut .....            | 2    | 2    |
| 23   | 130-13201  | Mounting plate .....                                       | 1    | 1    |

8

# 1 SPOOL CONTROL VALVE # 640-10004 (SD4 open center)

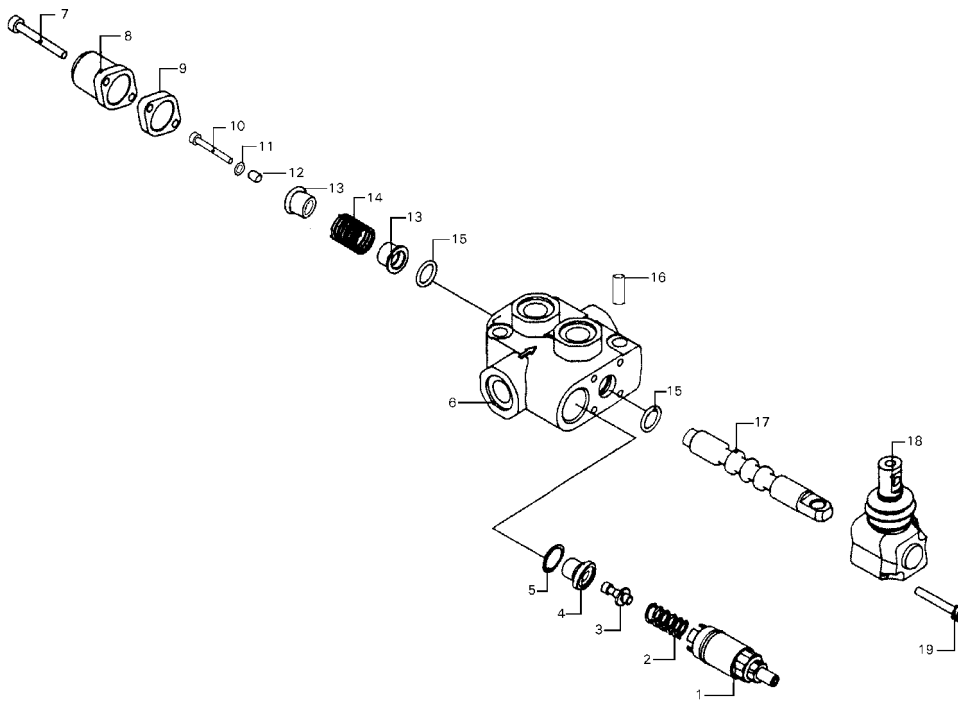

| REF. | PART # | CODE #      | DESCRIPTION              | QTY |
|------|--------|-------------|--------------------------|-----|
| 1    | 32167  | XKIT105211  | Relief valve .....       | 1   |
| 2    | 32169  | 3MOL314341  | Spring .....             | 1   |
| 3    | 32072  | 3OTT213260  | Spring seat pusher ..... | 1   |
| 4    | 32073  | 3ANE220210  | Ring .....               | 1   |
| 5    | 32074  | 3ANE120010  | Seal .....               | 1   |
| 6    | 32236  |             | Valve housing .....      | 1   |
| 7    | 32171  | 4VIT605018  | Bolt M5 x 18 .....       | 2   |
| 8    | 32079  | 3CAP210370  | Endcap .....             | 1   |
| 9    | 32172  | 3DIS12104N  | Spacer .....             | 1   |
| 10   | 32173  | 4VIT508035  | Bolt M8 x 35 .....       | 1   |
| 11   | 32174  | 3ANE112010  | Ring .....               | 1   |
| 12   | 32175  | 3ANE109091  | Ring .....               | 1   |
| 13   | 32176  | 3BOC119120  | Spring retainer .....    | 2   |
| 14   | 32177  | 3MOL419430  | Spring .....             | 1   |
| 15   | 32007  | 4GUA115926  | O-ring (121) .....       | 1   |
| 16   | 32179  | 4SPI510022  | Roll pin .....           | 1   |
| 17   | 32282  | 3CU1110100  | Valve spool .....        | 1   |
| 18   | 32086  | 3XLEV105000 | Lever .....              | 1   |

8

# HYDRAULIC MOTOR #DH 315

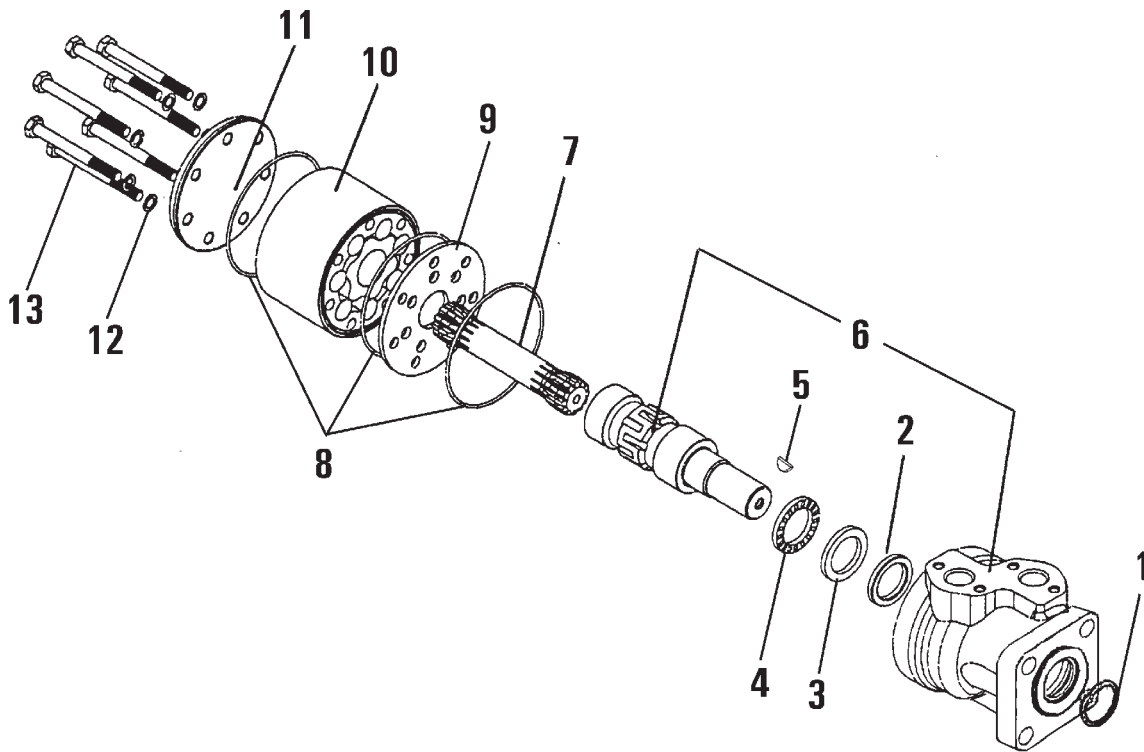







| REF. | CODE #   | DESCRIPTION                               | QTY      |
|------|----------|---|----------|
|      |          |   | DH 315   |
| 1    | 633B0370 | Dust seal ring .....                      | 1        |
| 2    | 633B0414 | Shaft seal BAKDH ring .....               | 1        |
| 3    | 151-5708 | Bearing race .....                        | 1        |
| 4    | 151-5709 | Axial needle bearing .....                | 1        |
| 5    | 682L9054 | Woodruff key .....                        | 1        |
| 6    | -----    | Housing and output shaft .....            | not sold |
| 7    | 151-2650 | Cardan shaft .....                        | 1        |
| 8    | 633B1173 | O-ring .....                              | 3        |
| 9    | 151-1713 | Distributor plate .....                   | 1        |
| 10   | 151-1186 | Gear wheel set .....                      | 1        |
| 11   | 151-2673 | End cover .....                           | 1        |
| 12   | 684X0076 | Washer .....                              | 6        |
| 13   | 681X0186 | Screw M8 x 1.25mm Din 931 x 70mm lg ..... | 6        |
| NI*  | 151-1286 | Set of seals .....                        | 1        |

\*NI = NOT ILLUSTRATED





8

# TORQUE CHART

## TORQUE SPECIFICATION TABLE

| Thread UNC and UNF |       | Grade 2  |      |                       |       | Grade 5    |      |                       |        | Grade 8*    |      |                       |        |
|--------------------|-------|---|------|-----------------------|-------|--|------|-----------------------|--------|--|------|-----------------------|--------|
| Bolt size          |       | Torque  |      |                       |       | Torque   |      |                       |        | Torque   |      |                       |        |
| Inches             | mm    | Pound feet<br>min.  | max. | Newton meters<br>min. | max.  | Pound feet<br>min.   | max. | Newton meters<br>min. | max.   | Pound feet<br>min.   | max. | Newton meters<br>min. | max.   |
| 1/4                | 6.35  | 5   | 6    | 6.8                   | 8.13  | 9  | 11   | 12.2                  | 14.9   | 12   | 15   | 16.3                  | 30.3   |
| 5/16               | 7.94  | 10  | 12   | 13.6                  | 16.3  | 17   | 20.5 | 23.1                  | 27.8   | 24   | 29   | 32.5                  | 39.3   |
| 3/8                | 9.53  | 20  | 23   | 27.1                  | 31.2  | 35   | 42   | 47.5                  | 57.0   | 45   | 54   | 61.0                  | 73.2   |
| 7/16               | 11.11 | 30  | 35   | 40.7                  | 47.4  | 54   | 64   | 73.2                  | 86.8   | 70   | 84   | 94.9                  | 113.9  |
| 1/2                | 12.70 | 45  | 52   | 61.0                  | 70.5  | 80   | 96   | 108.5                 | 130.2  | 110  | 132  | 149.2                 | 179.0  |
| 9/16               | 14.29 | 65  | 75   | 88.1                  | 101.6 | 110  | 132  | 149.2                 | 179.0  | 160  | 192  | 217.0                 | 260.4  |
| 5/8                | 15.88 | 95  | 105  | 128.7                 | 142.3 | 150  | 180  | 203.4                 | 244.1  | 220  | 264  | 298.3                 | 358.0  |
| 3/4                | 19.05 | 150   | 185  | 203.3                 | 250.7 | 270  | 324  | 366.1                 | 439.3  | 380  | 456  | 515.3                 | 618.3  |
| 7/8                | 22.23 | 160   | 200  | 216.8                 | 271.0 | 400  | 480  | 542.4                 | 650.9  | 600  | 720  | 813.6                 | 976.3  |
| 1                  | 25.40 | 250   | 300  | 338.8                 | 406.5 | 580  | 696  | 786.5                 | 943.8  | 900  | 1080 | 1220.4                | 1464.5 |
| 1 1/8              | 25.58 | -   | -    | -                     | -     | 800  | 880  | 1084.8                | 1193.3 | 1280   | 1440 | 1735.7                | 1952.6 |
| 1 1/4              | 31.75 | -   | -    | -                     | -     | 1120   | 1240 | 1518.7                | 1681.4 | 1820   | 2000 | 2467.9                | 2712.0 |
| 1 3/8              | 34.93 | -   | -    | -                     | -     | 1460   | 1680 | 1979.8                | 2278.1 | 2380   | 2720 | 3227.3                | 3688.3 |
| 1 1/2              | 38.10 | -   | -    | -                     | -     | 1940   | 2200 | 2630.6                | 2983.2 | 3160   | 3560 | 4285.0                | 4827.4 |

\* Thick nuts must be used with grade 8 bolts.

| Size of<br>screw | Thread | Pitch (mm) | Grade 4T   |      |                       |       | Grade 7T  |      |                       |       | Grade 8T   |      |                       |       |
|------------------|--------|------------|--|------|-----------------------|-------|---|------|-----------------------|-------|--|------|-----------------------|-------|
|                  |        |            | Torque   |      |                       |       | Torque  |      |                       |       | Torque   |      |                       |       |
|                  |        |            | Pound feet<br>min.   | max. | Newton meters<br>min. | max.  | Pound feet<br>min.  | max. | Newton meters<br>min. | max.  | Pound feet<br>min.   | max. | Newton meters<br>min. | max.  |
| M6               | UNC    | 1.00       | 3.6  | 5.8  | 4.9                   | 7.9   | 5.8   | 9.4  | 7.9                   | 12.7  | 7.2  | 10   | 9.8                   | 13.6  |
| M8               | UNC    | 1.25       | 7.2  | 14   | 9.8                   | 19    | 17  | 22   | 23                    | 29.8  | 20   | 26   | 27.1                  | 35.2  |
| M10              | UNC    | 1.5        | 20   | 25   | 27.1                  | 33.9  | 34  | 40   | 46.1                  | 54.2  | 38   | 46   | 51.5                  | 62.3  |
| M12              | UNC    | 1.75       | 28   | 34   | 37.9                  | 46.1  | 51  | 59   | 69.1                  | 79.9  | 57   | 66   | 77.2                  | 89.4  |
| M14              | UNC    | 2.0        | 49   | 56   | 66.4                  | 75.9  | 81  | 93   | 109.8                 | 126   | 96   | 109  | 130.1                 | 147.7 |
| M16              | UNC    | 2.0        | 67   | 77   | 90.8                  | 104.3 | 116   | 130  | 157.2                 | 176.2 | 129  | 145  | 174.8                 | 196.5 |
| M18              | UNC    | 2.0        | 88   | 100  | 119.2                 | 136   | 150   | 168  | 203.3                 | 227.6 | 175  | 194  | 237.1                 | 262.9 |
| M20              | UNC    | 2.5        | 108  | 130  | 146.3                 | 176.2 | 186   | 205  | 252                   | 277.8 | 213  | 249  | 288.6                 | 337.4 |
| M8               | UNF    | 1.0        | 12   | 17   | 16.3                  | 23    | 19  | 27   | 25.7                  | 36.6  | 22   | 31   | 29.8                  | 42    |
| M10              | UNF    | 1.25       | 20   | 29   | 27.1                  | 39.3  | 35  | 47   | 47.4                  | 63.7  | 40   | 52   | 54.2                  | 70.5  |
| M12              | UNF    | 1.25       | 31   | 41   | 42                    | 55.6  | 56  | 68   | 75.9                  | 92.1  | 62   | 75   | 84                    | 101.6 |
| M14              | UNF    | 1.5        | 52   | 64   | 70.5                  | 86.7  | 90  | 106  | 122                   | 143.6 | 107  | 124  | 145                   | 168   |
| M16              | UNF    | 1.5        | 69   | 83   | 93.5                  | 112.5 | 120   | 138  | 162.6                 | 187   | 140  | 158  | 189.7                 | 214.1 |
| M18              | UNF    | 1.5        | 100  | 117  | 136                   | 158.5 | 177   | 199  | 239.8                 | 269.6 | 202  | 231  | 273.7                 | 313   |
| M20              | UNF    | 1.5        | 132  | 150  | 178.9                 | 203.3 | 206   | 242  | 279.1                 | 327.9 | 246  | 289  | 333.3                 | 391.6 |

Use the above torques when special torque is not given.

NOTE: These values apply to fasteners as received from supplier, dry, or when lubricated with normal engine oil. They do not apply if extreme pressure lubricants are used.



---

---

## **WARRANTY**

---

ALBERTA AG-INDUSTRIES LTD. warrants this product to the initial purchaser for the period of one year from the date of purchase against defects in materials and workmanship.

We will replace or repair defective parts free of charge if they are returned to ALBERTA AG-INDUSTRIES LTD. 10012 - 93 rd Avenue, Westlock, AB, T7P 2P2 unless instructed otherwise.

Transportation charges are the responsibility of the customer. This warranty is not transferable.

Tires and gasoline engine are covered by the manufacturers of these items.

All ALBERTA AG-INDUSTRIES LTD. spare parts purchased are covered by a three (3) month warranty.

This warranty becomes void and nul if the equipment is modified, breaks down as result of an accident, if not operated according to manufacturer's recommendations, damaged by negligence or if maintenance has not been carried out as specified.

Our obligation is limited to the replacement or repair of the defective part. ALBERTA AG-INDUSTRIES LTD. accepts no responsibility for direct or indirect consequential damages of any kind.



**Alberta  
Ag-Industries Ltd.**

10012 - 93 Ave.,  
Westlock, AB, T7P 2P2  
Phone: 1-800-661-3606, Fax: (780) 468-8318