

AgLand

Macerator 6600™



Assembly Instructions
Operators Manual
Parts Catalog

INDEX

INTRODUCTION	PAGE 3
SAFETY PRECAUTIONS	PAGE 4
SPECIFICATIONS	PAGE 5
ASSEMBLY	PAGE 6 - 8
TRANSPORT	PAGE 9
OPERATION	PAGE 10 -13
MAINTENANCE	PAGE 14 -16
LUBRICATION	PAGE 17
AIR SYSTEM	PAGE 18
HYDRAULIC SYSTEM	PAGE 18
TROUBLE SHOOTING	PAGE 19 - 20
PARTS LISTS - MAIN UNIT	PAGE 22 - 32
ATTACHMENTS	PAGE 33 - 35
WARRANTY	BACK COVER

Replacement Parts

To obtain prompt, efficient service, always remember to give the dealer the following information:

1. Correct part description
2. Model number of the machine
3. Serial number of the machine

The serial number is important in identifying your machine. It contains information for ordering replacement parts and options, which may vary, depending on the serial number identification.



(Serial # plate inside right side cover)

Measurements are given in U.S. units, followed by the equivalent in metric units. Hardware sizes are given in inches for the U.S. hardware and millimeter for metric hardware.



Congratulations, you have just purchased the AgLand Macerator 6600

To get the maximum benefit from your Macerator we suggest that you read the owners manual carefully.

The Macerator is designed to condition the hay for a super fast dry down while maintaining the maximum amount of nutrients and colour. Dry down time is reduced from up to 100 hours to as little as 32 hours or less. The Macerator utilizes special steel macerator rollers each running at a different speed allowing for a measured nicking or cutting of the top half of the stem or leaf for greater air exposure. The low profile, heavy-duty pickup, with extra width rollers allow for rapid operation with minimal leaf loss.

The roller system of the Macerator is a patented design, to allow for the right amount of maceration without cutting up the hay.

These operating and maintenance instructions have been compiled from extensive field experience and engineering data. Some information is general in nature due to unknown and varying conditions.

However, through experience and these instructions, you will be able to develop operating procedures suitable to your particular situation.

Please study this manual from the beginning to end BEFORE operating your new Macerator 6600. Pay special attention to the safety cautions in this book and on your equipment. Should anyone else operate this equipment be sure that they understand All Safety, Operating and Maintenance information presented in this manual.



WARNING

Some pictures in this manual show the machine with shields removed to allow for a better view of the subject of the picture. The machine must never be operated with any of the shields removed!

“Right” and “Left”, as used throughout this manual, are determined by facing the direction the machine will travel when in use.

The photographs, illustrations, and data used in this manual were current at the time of printing; but due to possible inline production changes, your machine can vary slightly in detail. The Manufacturer reserves the right to redesign and change the machine as necessary without notification.

SAFETY PRECAUTIONS

Read this manual completely and understand all operating instructions and precautions before attempting to operate or service your machine.

Understand that your safety and the safety of other persons is measured by how you service and operate this machine. Know the positions and operations of all controls before you try to operate this machine. **MAKE SURE YOU CHECK ALL CONTROLS IN A SAFE AREA BEFORE STARTING YOUR WORK.**

The Safety Alert symbol identifies important safety messages on the machine and in the manual. When you see this symbol, be alert to the possibility of personal injury or death. Follow the instructions in the safety message.

Three Big Reasons

1. Accidents disable and kill.
2. Accidents cost.
3. Accidents can be avoided.

The safety information given in this manual does not replace safety codes, insurance needs, or state and local laws. Make sure your machine has the correct equipment needed as specified by the local laws and regulations!

SAFETY ALERT SYMBOL



**This Safety Alert symbol means -
ATTENTION!
BE ALERT!
YOUR SAFETY IS INVOLVED!**

**WATCH OUT FOR THIS SYMBOL ON
YOUR MACERATOR 6600 AND
THROUGHOUT THE MANUAL.**

SIGNAL WORDS:

DANGER - An immediate and specific hazard which **WILL** result in severe personal injury or death if the proper precautions are not taken.

WARNING - A specific hazard or unsafe practice which **COULD** result in severe personal injury or death if proper precautions are not taken.

CAUTION - Unsafe practices **COULD** result in personal injury if proper practices are not taken, or as a reminder of good safety practices.

Model 6600 AgLand Macerator

Dimensions

Width -	10'6" (320 cm)
Length -	11'4" (345 cm)
Height - operation	3'6" (107 cm)
transport	4'10" (147 cm)
Weight -	3600 lbs (1633 Kg)

Tires (4)

Tire size -	26 x 12 x 12
Pressure -	20 psi (138 kPa)
Wheel hub -	6 bolt
Wheel torque -	85 ft. lbs. (115.2 NM)

Pickup

Width (inside flare) -	5'11" (180 cm)
Clearance under pickup when raised -	14" to 16" (35.5 to 40.5 cm)
Tooth clearance when raised -	10" to 12" (25 to 30 cm)

Rollers

Width of rubber feed rollers	5'6" (168 cm)
RPM of rubber feed rollers	428 @ 540 pto
Width of steel Macerator rollers	5'6" (168 cm)
RPM of top steel Macerator roller	540 @ 540 pto
RPM of bottom steel roller	810 @ 540 pto
Spacing between bottom and top Macerator roller	1/32" (1 mm)

Pickup tooth spacing -	2 3/4" (7 cm)
Height when working -	19" (48 cm)

Some weights and measurements in this column are approximate.

Tractor Requirement

Suggested minimum tractor size -	80 HP(60 KW)
* Note : Tractor should be of sufficient size to maintain operator control in all situations.	

Air System

Size of Air Pressure tank	10 gallon (38 l)
Maximum Air Pressure in tank	120 psi
Hydraulic outlets required -	1
Suggested minimum underframe clearance -	15" (38 cm) to allow swath to flow freely under tractor

Operating speed

Approximate range -	5 to 10 mph (8 to 16 k/h), depending on crop conditions
----------------------------	---

Swath Size

Width up to -	5' (1.5m)
----------------------	-----------

Cut Width

Maximum	14' (427")
----------------	------------

Capacity

Up to -	2 1/2 ton/acre
----------------	----------------

NOTE: All specifications, statements and information shown in this manual are believed to be accurate at the time of printing. Specifications are subject to change without notice

ASSEMBLY

SWATH INVERTER (MOLD BOARD)

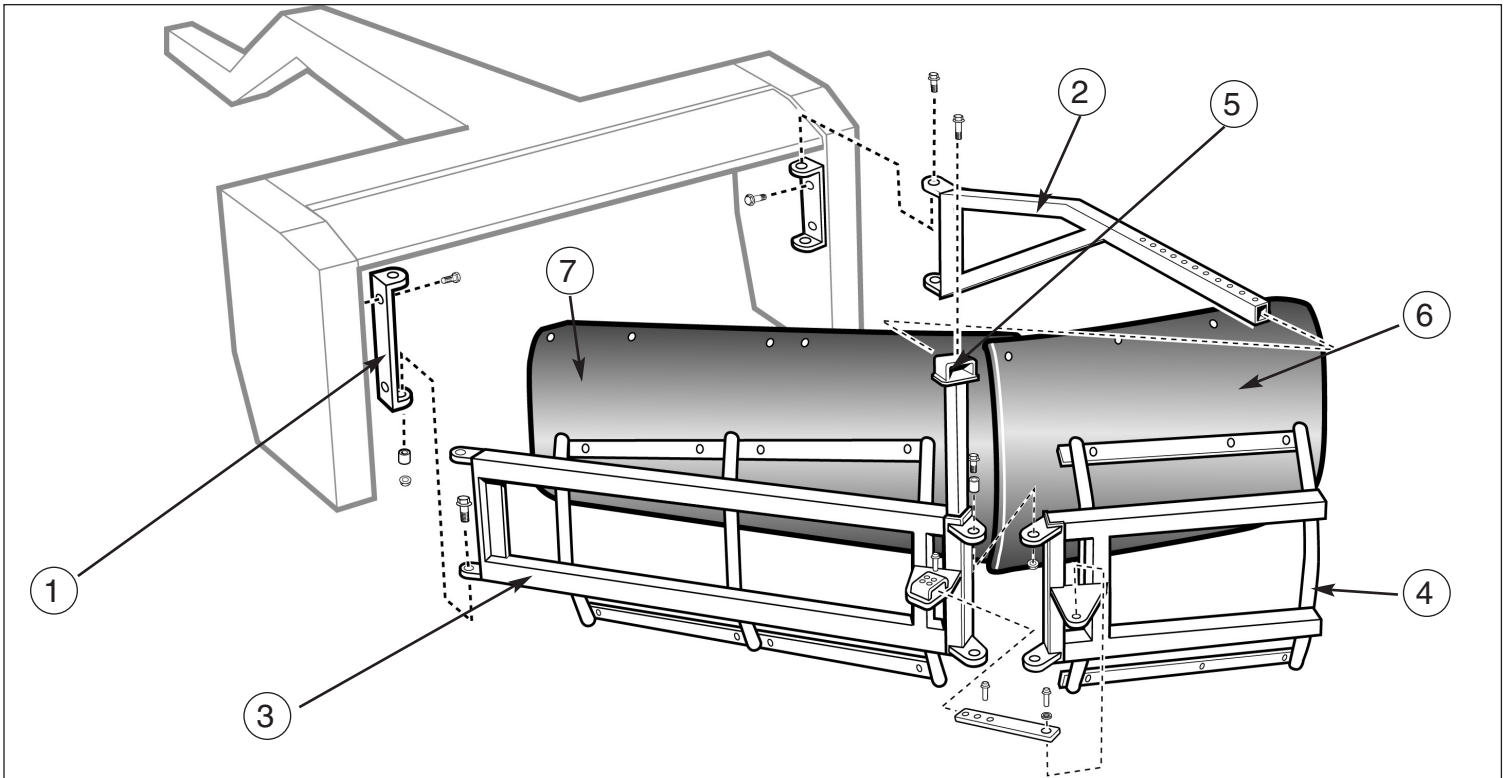

1. Install right and left mounting brackets (1) to macerator frame with 3/8" x 1" flange bolts

2. Install right side adjustment bar (2) to mounting bracket, using 1/2" x 1 1/2" hex bolts with bushing, washer and hex nut.

3. Install left side main frame (3) to the left side mounting bracket, using 1/2" x 1 1/2" hex bolts with bushing, washer and hex nut.

4. Attach right side main frame (4) to left side main frame (3) with using 1/2" x 1 1/2" hex bolts with bushing, washer and hex nut.
Do not tighten adjustment bolts (8)

5. Slide main frame adjustment bracket (2) through the adjustment bar (5) and insert 1/2" x 3" pin

Mold board sheet installation

6. Install short mold board (6) to outside portion of main frame (3) using 3/8" x 3" carriage bolts and flange nuts. DO NOT tighten bolts at this time.

7. Install longer mold board sheet (7) on to the left side

of the main frame (3) using 5/16" x 3/4" carriage bolts, overlapping the short mold board sheet.

8. All bolts holding the moldboard sheets can now be fully tightened.

9. Adjust angle of moldboard by moving adjustment bracket (2) in or out of adjustment bar 5 to preferred moldboard angle and insert 1/2" x 3" pin

The tighter angle will result in less inversion, The wider angle will give you a greater inversion.

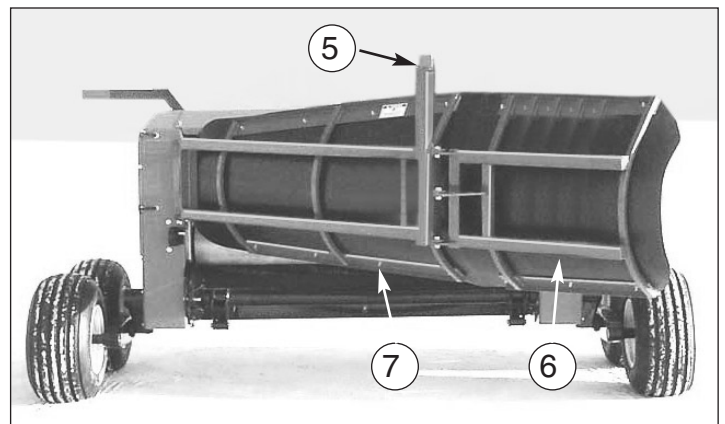

SPREADER ATTACHMENT

The Spreader attachment allows the Macerator to spread a wider swath and leave a thinner layer on the field for greater sun and wind exposure.

The Spreader attachment consist of only three pieces and easily bolts on to the rear main frame.

1. Insert 3/8" x 1" flange bolts through side panels and attach to main frame (1). Do not tighten bolts.

2. Mount top plate(3) to brackets (2) with 5/16" x 3/4" flange bolts.

3. Insert 5/16" x 3/4" bolts through top lip of bracket and attach to top cover of main frame (1)

3. Tighten all bolts evenly.

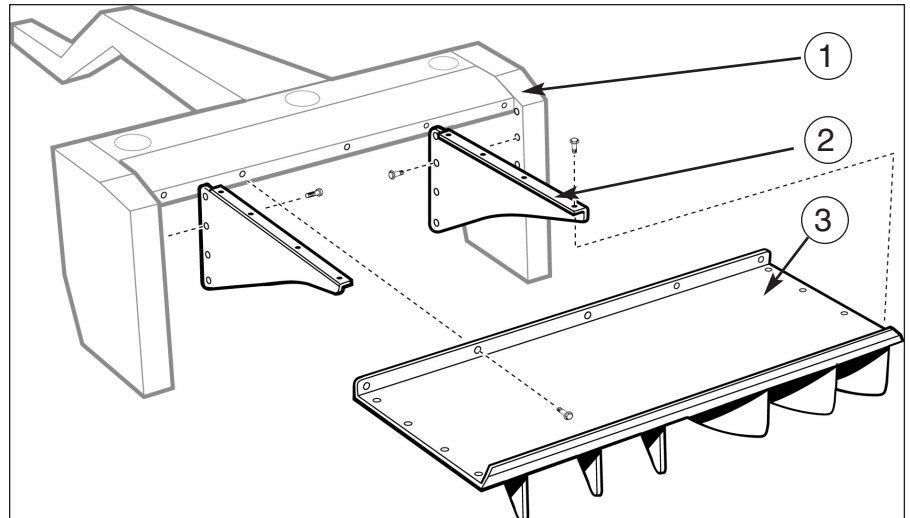

Spreader attachment

WINDROWER ATTACHMENT

The windrower attachment allows you to direct the cut hay down to keep a tighter windrow, or out for a wider swath width.

1. Insert 3/8" x 1" flange bolts through side panels (1) and attach to main frame (7) Do not tighten bolts.

2. Mount top plate (2) to brackets (1) with 5/16" x 3/4" flange bolts.

3. Attach top plate (2) to main frame (7) with 5/16" x 3/4" flange bolts.

4. Mount one side brackets (3) to bracket (1) with 3/8" x 3/4" flange bolts.

5. Insert windrow baffle (5) into hole of side brackets (3)

6. Mount the other side bracket (6) to side panel with 3/8" x 3/4" flange bolts.

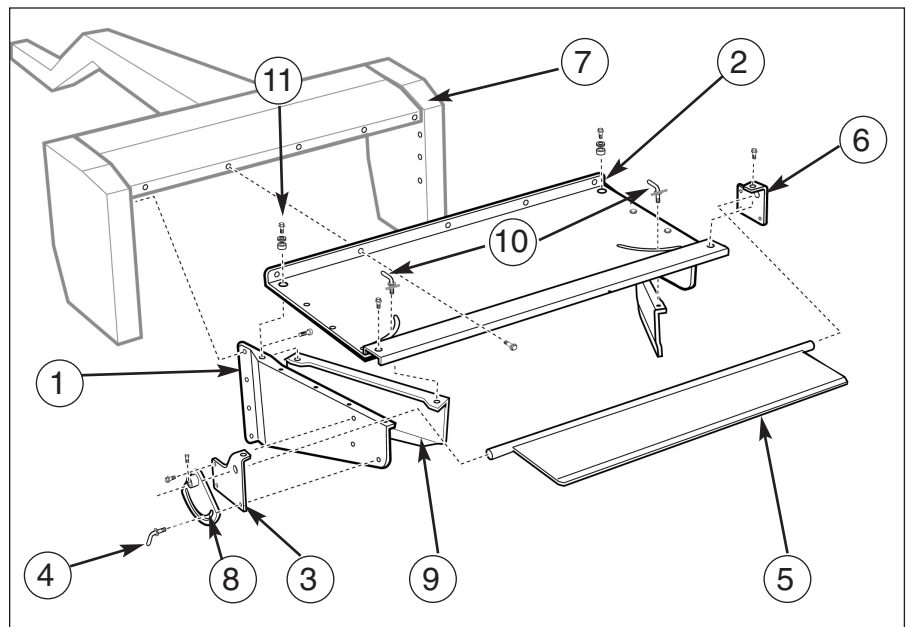

Windrower attachment

7. Mount adjustment bracket (8) using 5/16 x 1 1/2 socket head cap screw and insert wing bolt (4)

8. Install left & right side width adjusters (9) using 3/8" x 1" bolt & bushing (11) through top plate (2).

9. Insert wing bolt (10) through slot into width adjuster (9).

ASSEMBLY

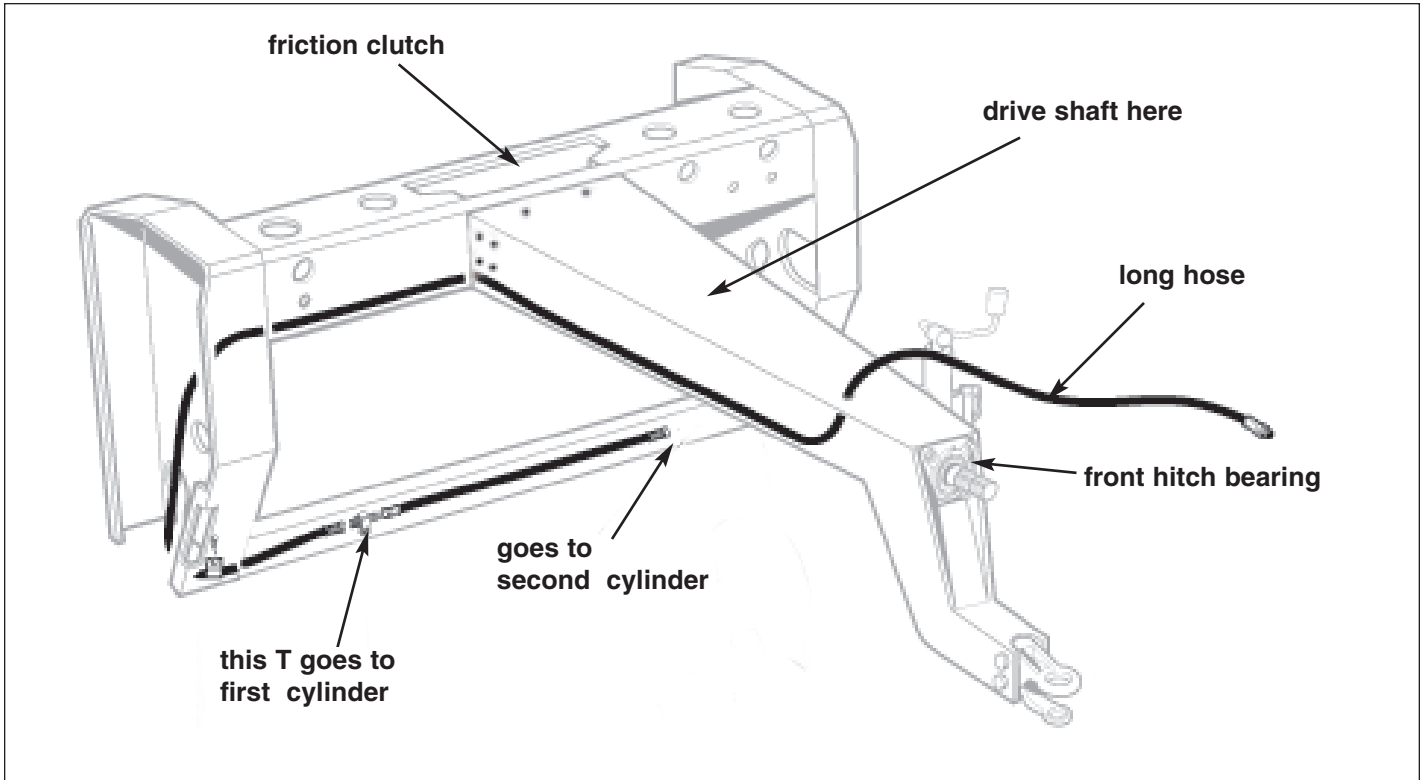

ATTACHING HITCH

Sometimes the hitch will be shipped detached from the unit to allow for a more compact shipping package.

1. Bolt Hitch to main frame using fourteen $5/8 \times 1 1/2$ " carriage bolts. Be sure bolts are securely tightened all around

2. Remove bearing on front of hitch, slide drive shaft into friction clutch through front bearing hole and reinstall bearing and tighten shaft bolts on friction clutch.

3. Install the long hydraulic hose securely as shown above.

The Macerator can easily be moved from location to location. When transporting follow this procedure.



TRANSPORT SAFETY

1. Make sure you are in compliance with all local regulations regarding transporting equipment on public roads and highways.
2. Make sure the SMV(Slow Moving Vehicle) emblem and all the lights and reflectors that are required by the local highway and transport authorities are in place, are clean and can be seen clearly by all overtaking and oncoming traffic.
3. Do not allow anyone to ride on the Macerator or tractor during transport.
4. Do not exceed 32 km/h (20 mph). Reduce speed on rough roads and surfaces.
5. Use a retainer on the drawbar pin and install a safety chain before transporting.
6. Always use proper lighting on the tractor when transporting.
7. Stay away from overhead electrical wires. Electrocutation can occur without direct contact.
8. When using a ball and socket, make sure the locking jaws are pinned securely in position.
9. Do not rely on the pickup lift hydraulic cylinder to keep the pickup raised! Be sure pickup reel is in raised position and lever is secured with the pick up lock-up pin provided.

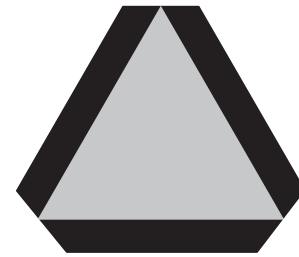

Slow moving vehicle emblem



Hitch and safety chain

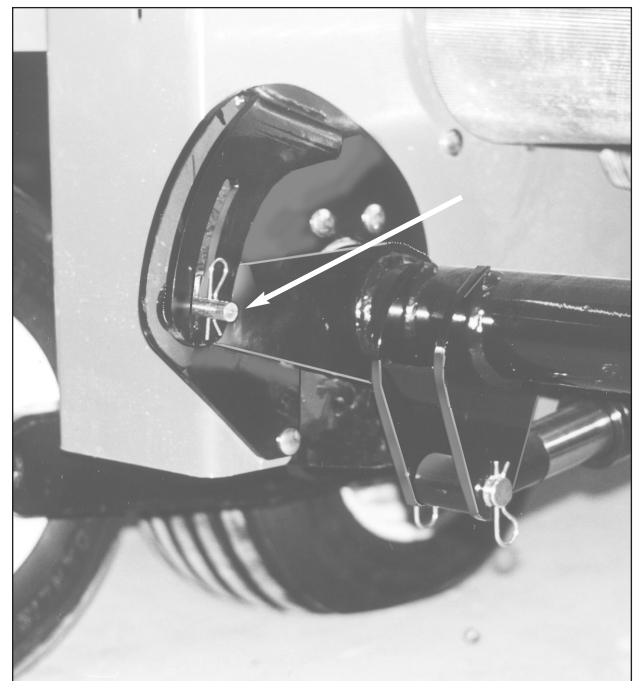

Lock travel pin in place



Operating Safety

1. REVIEW ALL SAFETY INSTRUCTIONS with all operators before allowing them to operate the equipment . Follow up at least once a year!
2. All shields and guards must be in position and securely fastened before operating the Swath Inverter.
3. Only use a tractor with ROPS cab and seat belt. Be careful when operating close to a road or building, the machine can throw stones and other debris during operation.
4. Emphasize the importance of safety when working around and operating the machine.
5. Do not allow or carry riders on any part of the equipment or tractor at any time.
6. Always keep hands, feet, and clothing away from moving parts.
7. Always lower the pickup to the ground when parking.
8. Use a retainer or draw pin to secure the lifting lever of the pickup before transporting equipment.
9. Use safety chain at all times.
10. NEVER attempt to unclog the machine when the tractor is running and hydraulic system is operating.
11. Before servicing, adjusting, repairing, or unplugging, stop the tractor engine, remove the ignition key, set the park brake, disengage hydraulics, and wait for all moving parts to stop.
12. Keep hands, feet, and clothing away from the pickup area when adjusting the pickup speed to avoid entanglement hazard. Never check drive chains while machine is running.
13. Be sure to relieve all pressure from hydraulic lines before disconnecting them. Before applying pressure to the system, make sure all connections are tight and that hoses and lines have not been damaged.
14. Always use adequate safety warnings and lights when transporting the machine on public roads.
15. Be sure the Slow Moving Vehicle emblem is installed at the rear of the machine. Check with local law enforcement regarding any specific requirements.

Use with a tractor having a minimum of 80hp (59kw). Tractor should have sufficient ground clearance for swath to pass cleanly under it.



PTO SPEED

Unless otherwise specified, units are shipped with 1000 PTO speed. Conversion kits from 540 to 1000 or from 1000 to 540 are available from your dealer. See page 9 for installation instructions.

The PTO should be run at approximately 1000 rpm. The front rubber rolls run at 792 rpm and the rear upper steel roller runs at 1000 rpm at a tractor pto speed of 1000. The bottom rear steel roller runs at 1500 rpm at 1000 tractor pto speed.

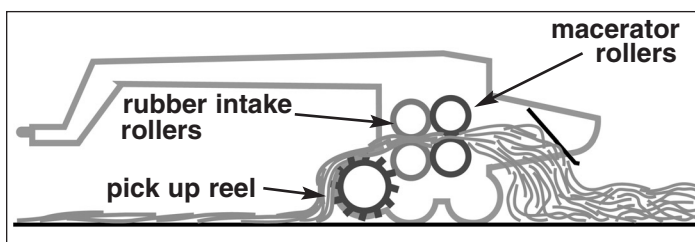

PICKUP HEIGHT & ADJUSTMENT

The Macerator 6600 pickup should be adjusted so that it will cleanly pick up all material of the field without gouging the soil. You may have to reset the height a few times to arrive at the best working height.

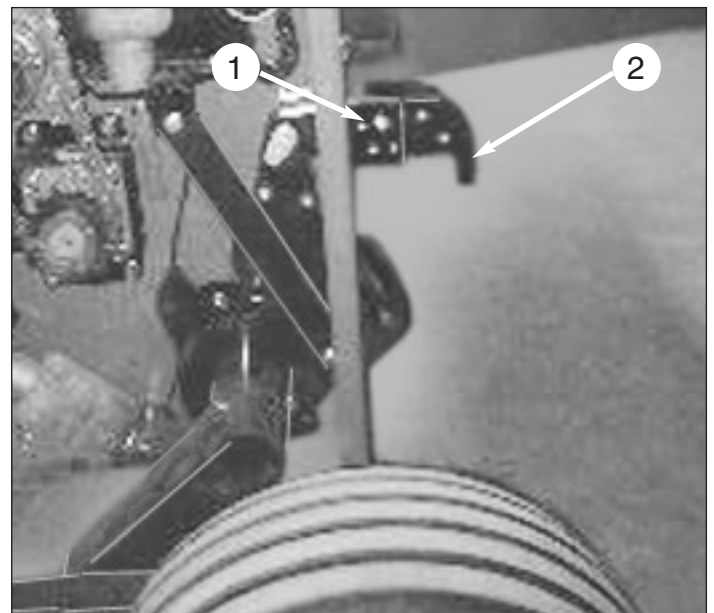

RAISING OR LOWERING THE PICKUP

1. If your pickup is too low to the ground, use your tractor hydraulic cylinder control to raise the pickup approximately 1/2" - 1" off the ground.

2. Remove pin (1) and slide adjuster bar (2) to desired height (pushing bar in raises machine, pushing bar out lowers the unit).

3. Reinsert pin and lock in place.

OPERATION

STEEL ROLLER ADJUSTMENT

For best results adjust the Macerator 6600 for your specific field conditions. The smaller the gap between the steel serrated rollers the more aggressive will be the maceration of the hay. Both the space between the rollers and the air pressure need to be adjusted for maximum efficiency.

ADJUSTING GAP BETWEEN STEEL ROLLS

1. Raise the pickup, using your hydraulic cylinders, to the full upward position and put the “travelling” safety pin in place.
2. Open the right and left panels.

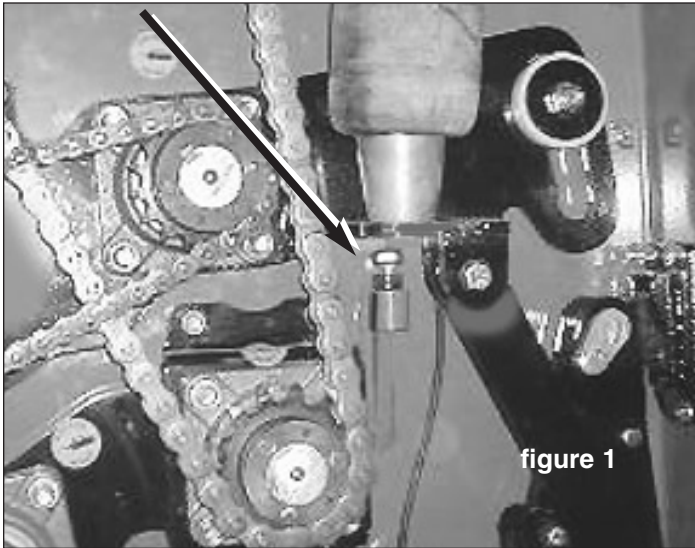

3. The roller stop, shown under the top air bag, in figure 1, consists of a 5/8” bolt with a 5/8” nut. Loosen the nut and turn the bolt in to narrow the gap or out to widen the gap. Use a spark plug gauge to measure the gap and set at **no less than 1/32” or 1 mm**

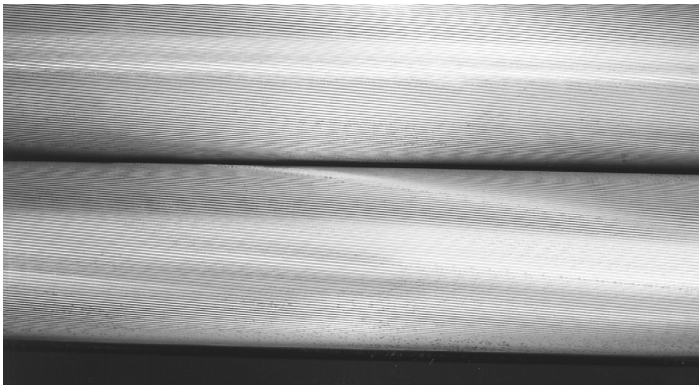

4. Be sure to set the gap exactly the same on both sides! Tighten the locking nuts and close cover.

PREPARATION - AIR SYSTEM

The purpose of the air system on the Macerator 6600 is to act as a shock absorber as well as keeping continuous pressure on the rolls.

Before heading out to the field make sure the air pressure tank has a minimum of 100 psi pressure. This should give the operator sufficient air supply for the day.

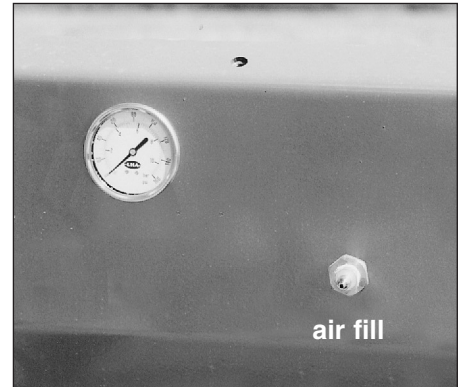

The pressure can make a difference on how well the machine performs on the field. While the pressure on the rubber rolls may not be as crucial too much pressure on the steel rolls will result in considerable leaf loss and some plugging may result in short wet hay.

RUBBER ROLLER ADJUSTMENT



The rubber rollers are designed to take the material off the pick-up and feed it into the steel rollers. The rubber rollers do not crush or crimp the hay and the pressure on these rollers is not as crucial as on the steel rollers.

Rubber Rollers continued...

As a standard setting, we recommend 30-40 psi pressure on the rubber rollers. Regulate the pressure by pulling out the knob on the regulator marked **rubber rollers** and turning the knob clockwise or counter clockwise. When turning the knob counter clockwise you should hear the air escaping from the regulator.

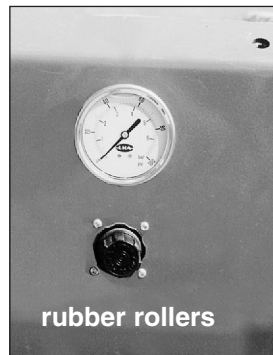

In extreme conditions, increase or decrease the pressure. For example very heavy swaths may require less pressure.

STEEL ROLLERS

The steel serrated rollers (rear) take the material from the rubber rollers and kink or bend the stem approximately every 1/8”.

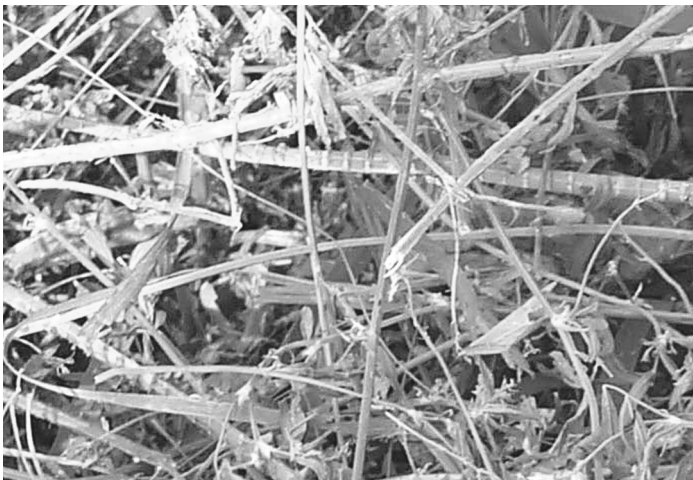

To achieve the right setting some field testing may be necessary.

1. Pull out knob on air regulator marked steel rollers and turn knob clock/ counter clockwise to set pressure to the steel rollers at approximately 30 psi.



FIELD TEST.

2. If you experience too much leaf loss or the plants are crushed too intensely, lower the air pressure.
3. If there is not enough maceration - increase pressure to the rollers by increasing the air pressure.

MAINTENANCE

check list



USE GOOD SAFETY PRACTICES WHEN WORKING ON THIS MACHINE

Before doing any maintenance or service work on the machine, you must:

- Park machine on a solid level surface.
- Disengage all power
- Put the tractor transmission in PARK or apply the tractor parking brake.
- Stop the tractor engine and take the key with you.
- LOOK AND LISTEN! Make sure all moving parts have stopped.
- Install the cylinder safety stops, if applicable.
- Block the Macerator up securely before working

FIRST TIME USE

- Tighten hub bolts 1-4* after the first 1/2 hour of operation and repeat procedure after 1 1/2 hours and 3 hours.

***IMPORTANT**

Hub 1 - tighten to 348”/ lbs

Hubs 2-4 - tighten to 192”/ lbs

DAILY

- Check and tighten all hub bolts.
- Lubricate all items as required*.
- Remove all dirt and crop deposits from machine.

EVERY 8 HOURS OF USE

- Grease all points. All grease point are identified with a yellow label, replace labels when missing*.

AFTER THE FIRST 25 HOURS OF USE

- Check sprockets for set screw tightness

EVERY 100 HOURS OF USE

- Clean, repack and adjust wheel bearings.

AT THE BEGINNING OF EACH SEASON

- Review all safety instructions.
- Carefully inspect all components for excessive wear or hazardous conditions.
- Lubricate the machine at all lubrication points*.
- Clean, repack and adjust wheel bearings**.
- Check tires for correct inflation pressure.
- Tighten bolts.

* **SEE LUBRICATION SCHEDULE AND PROCEDURES ON PAGE 17**

** **SEE REPLACING OR REPACKING WHEEL BEARINGS ON PAGE 16**

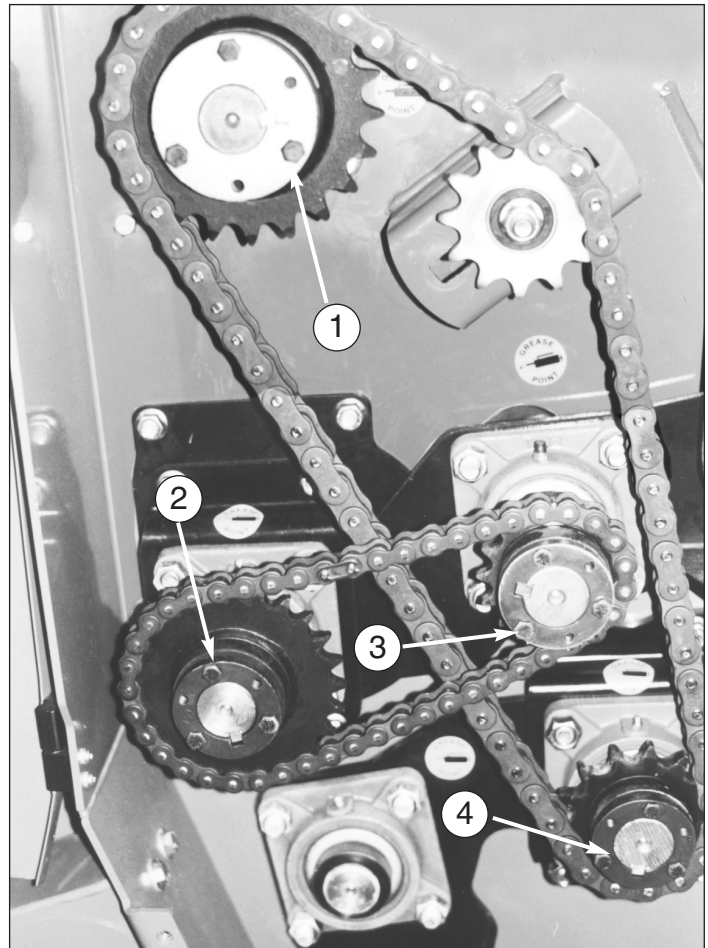

Check that the chain is not riding up on sprocket teeth (especially the large sprocket) as this would indicate a worn out chain and requires replacement of chain. Regular lubrication with chain lubricant, proper adjustment, and replacement of worn chains will ensure proper function of the Macerator and prolong the life of the sprockets.

ROLLER DRIVE CHAIN REPLACEMENT

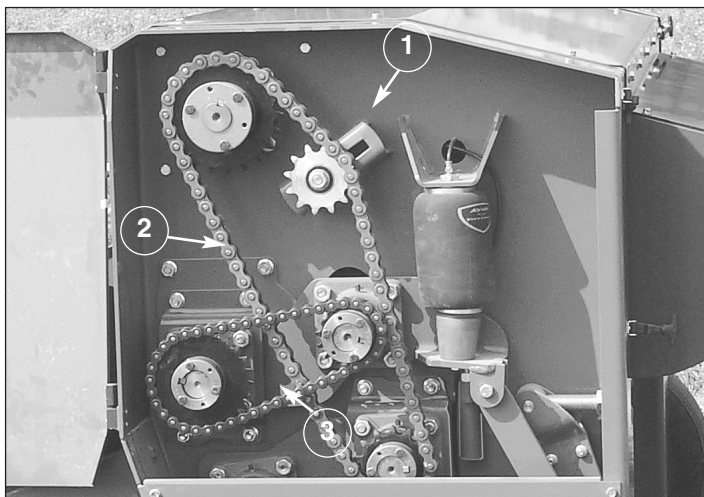
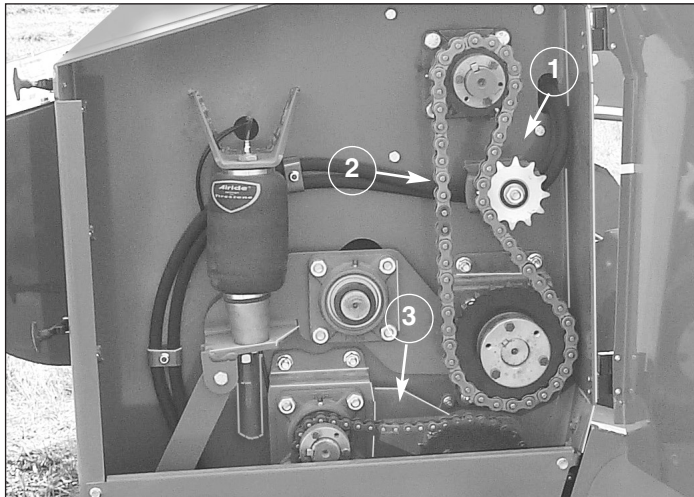

Replace worn or damaged chain as follows:

1. Raise pick-up
2. Remove side covers.
3. Remove the connector link from the chain and remove chain from sprockets.
4. Replace worn sprockets and bearings. (Be sure all sprockets are securely tightened).
5. Install new chain.
6. Move sprocket (1) to allow for approximately 1/2" (13mm) deflection when slight pressure is

- applied to the longest span of the chain (2)
7. Short chains require non adjustment.

8. Reinstall covers!!

BEARING REPLACEMENT

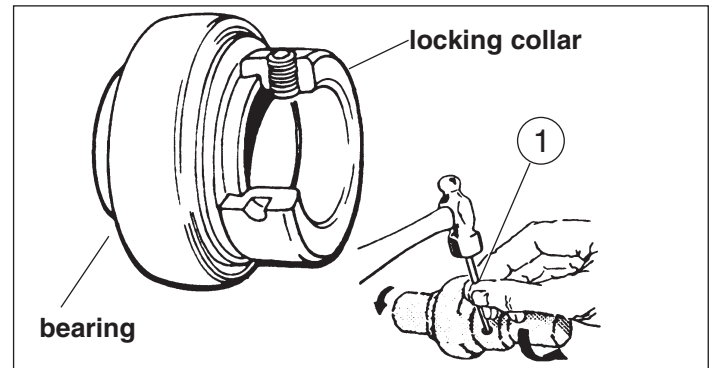

Sealed ball bearings are held in position on the shaft by a locking collar which is rotated to lock the assembly on the shaft and secured by a set screw. To remove Bearing:

1. Loosen set screw
 2. Use a drift punch inserted in the drift pin hole to rotate and loosen the locking collar (1). Rotate the locking collar counter clock wise.
 3. Remove the locking collar.
 4. Support the shaft, for easier assembly later.
 5. Remove the bolts for the bearing flanges.
 6. Slide the bearing and the flanges from the shaft.
- Note: Cleaning paint and corrosion from the shaft will make removal easier.*
7. Put on the new bearings and flanges.
 8. Install bolts making sure the bearing is straight within the flanges.
 9. Replace locking collar on the shaft. Rotate the locking collar clockwise until lightly engaged. Tighten the collar by hitting it with a drift pin punch inserted in the drift pin hole rotating it further clockwise.
 10. Tighten set screw.

After lubricating, servicing, or adjusting the Macerator, make sure all tools and equipment are removed from Macerator to prevent damage.

MAINTENANCE

REPLACING OR REPACKING WHEEL BEARINGS

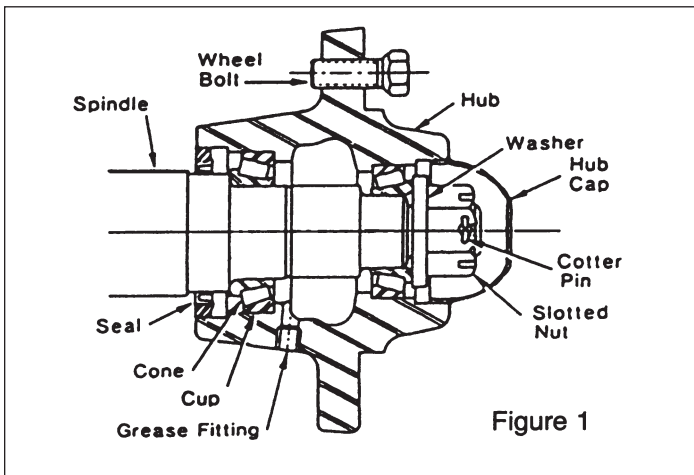

Figure 1

1. Remove wheel hubs and disassemble.
2. Clean bearings, seals, caps, washers, nuts and hubs with kerosene or other solvent.
3. Replace bearings or seals if worn or damaged.
4. Pack bearing cones and seals with No. 2 multi-purpose lithium grease or equivalent.
5. Reassemble hub and bearings. (fig 1)
 - a. Press oil seal very lightly against the shoulder on the spindle.
 - b. Press cups against the shoulder in the hub.
 - c. Press sleeve to the shoulder in the hub.
 - d. Place hub on shaft taking care not to damage the seal!
 - d. Adjust the wheel bearing nut until there is a noticeable drag while turning the wheel.
Do Not back the nut off.
 - e. Secure nut with a cotter pin.

PICKUP TEETH, WRAPPERS, WEAR STRIPS

Check for bent, broken or loose parts. If it is necessary to replace teeth or related parts, proceed as follows.

1. Ensure that pickup is blocked securely. Loosen the bolts, holding the wrapper(s) on pickup. (see fig. 2) Slide wrapper forward, and remove the wrapper from the bolts.

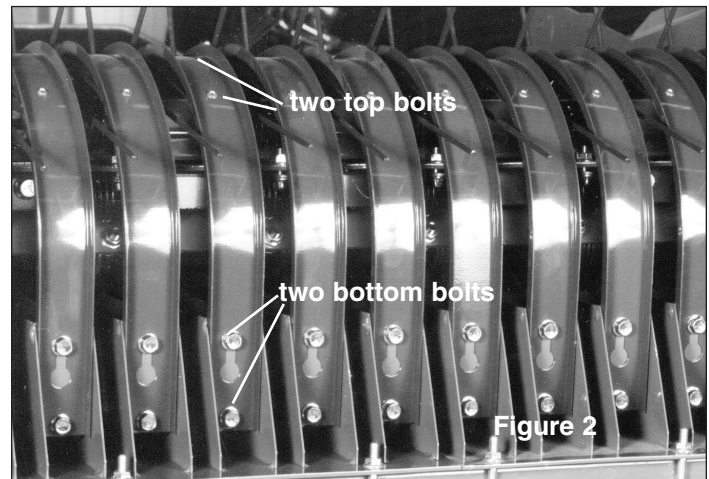

Figure 2

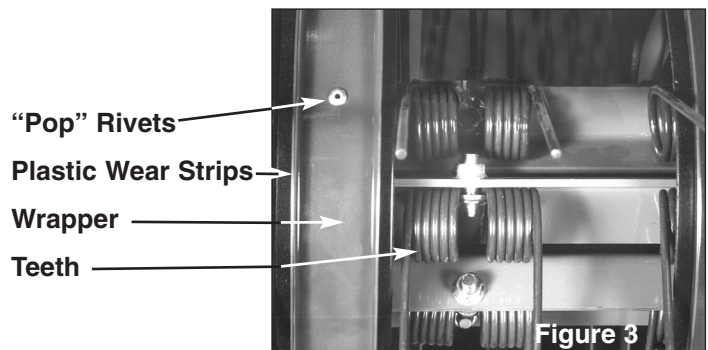

Figure 3

2. Should the plastic wear strip require removal and replacement, drill out or carefully grind off the "pop" rivets. Replace strip with new rivets(fig.3).
3. Install new teeth or wrapper(s).

We recommend a good grade SAE multi-purpose high temperature grease.

Use a manual grease gun for all greasing. Air powered grease guns may damage the seal on the bearings.

Wipe all grease fittings with a clean cloth before greasing to avoid injecting dirt or grit in the bearings.

Every 8 hours of use

Coat chain with chain lubricant to prevent rust and seizing , figure 1 and 2.

Every 100 hours of use or at the beginning of the season

Grease all the sealed bearings, front rollers (two places) rear rollers (two places) and drive shaft two places, figure 1 and 2.

Clean, repack and adjust wheel bearings. Grease wheel bearings (nipples in hub), just enough to force out moisture, figure 3.

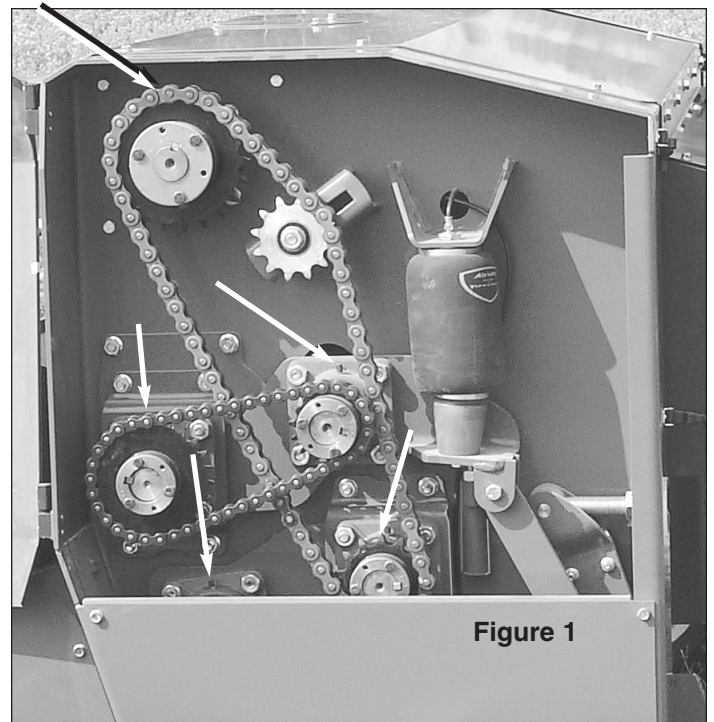

Figure 1

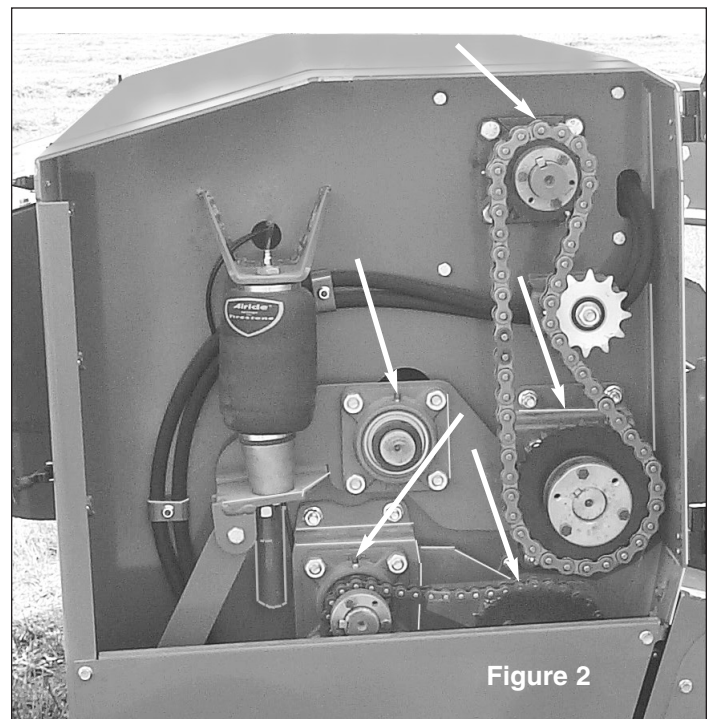

Figure 2



Figure 3



HYDRAULIC AND AIR SAFETY

HYDRAULIC SAFETY

Make sure that all components in the hydraulic system are kept in good condition and are clean.

Replace any worn, cut, abraded, flattened or crimped hoses and metal lines.

Do not attempt any makeshift repairs to hydraulic lines, fittings, or hoses by using tape, clamps, or cements. The hydraulic system operates under extremely high pressure: 1600 to 2300 PSI (11 033 to 15 859 kPa). Such repair will fail suddenly and create unsafe conditions.

A high pressure concentrated stream of hydraulic fluid can pierce the skin. If such happens, seek immediate medical attention as infection and toxic reaction could develop.

Wear proper hand and face protection (eg. face shield) when searching for a high pressure hydraulic leak. Use a piece of wood or cardboard as a backdrop instead of hands.

Before applying pressure to the system, make sure all connections are tight and that line, hoses, and couplings are not damaged.

AIR SAFETY

Make sure all hoses and bellows are kept in good condition and are clean.

Replace any damaged lines or bellows.

Do not exceed 110 lbs air pressure in tank and 90 lbs. in air bags.

Think SAFETY!
Work SAFELY!

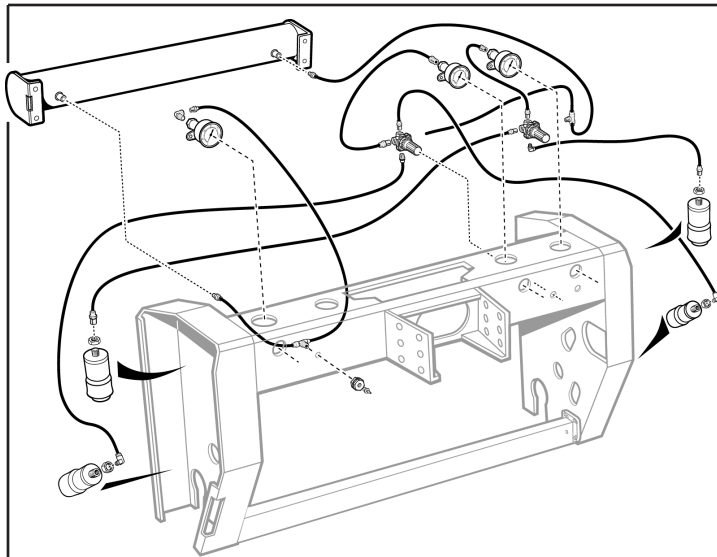

AIR SYSTEM

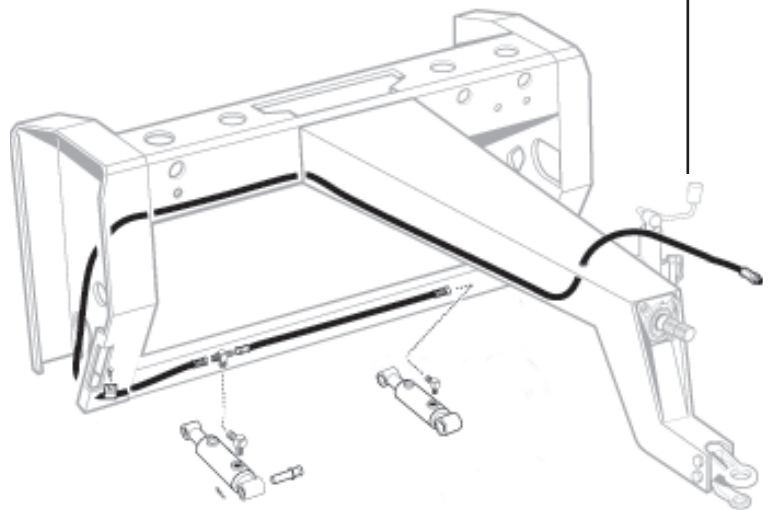

HYDRAULIC SYSTEM

PROBLEM	POSSIBLE CAUSE	SOLUTION
Pickup is skipping swath or not picking cleanly	Missing or broken pickup teeth	Replace missing teeth
	Pickup to high	Adjust pickup height
	Driving to fast for pickup speed	Use lower tractor gear with higher rpm
	Not following the same direction as swath was cut.	Follow the same direction as swath was cut
Material wrapping in pickup	Nylon wear plates missing or worn	Replace missing or worn nylon pads
	Pickup & travel speed not matched	Match pickup & ground speed as close as possible
Breakage or bending of pickup teeth	Running pickup to low	Adjust pickup height
	Excessive pickup rotation speed in rough or rocky conditions	Reduce pickup or ground speed
Excessive noise from chains or sprockets	Chain or sprockets worn	Replace parts as needed
	Incorrect tension chain	Adjust as per "servicing" section
	Chain dry or rusted	Use proper lubrication on chains
Excessive noise or heat from gear box	Insufficient oil in gear box	Top up gear oil as needed
	Worn or broken parts inside gear box	Replace parts as needed
Air pressure does not hold in air tank and air bags	Broken air line	Repair or replace line as needed
	Torn or punctured air bag	Replace air bag as needed
	Air regulator not working	clean or replace air regulator
Pickup does not rise	Worn or punctured hydraulic cylinder or hydraulic oil line	Replace hydraulic lines & cylinders as needed
Pickup height adjustment does not hold	Broken or worn parts on adjuster	Replace worn parts as needed
Rubber rolls not feeding properly	Air pressure to high or to low Gap between rollers to tight or to wide	Adjust air pressure using the regulator Adjust gap width
Wax build up on steel rolls	Temperature & hay conditions cause the wax to come off the plant and stick to the rollers	The wax will come off after the rollers cool down. A thin layer of wax/leaves will build up on the rollers
Excessive leaf loss	Too much air pressure on steel rollers	Release air pressure
	Hay conditions to dry	Condition hay early in the morning
	The gap between steel rollers is to narrow or the rolls going to fast	Adjust gap between steel rollers

TROUBLE SHOOTING

PROBLEM	POSSIBLE CAUSE	SOLUTION
Hay is not being macerated	Not enough air pressure on steel rolls	Adjust air pressure as required
	Gap between rollers is too wide	Narrow the gap between steel rollers
	Windrow is too thick	Cut wider or thinner windrows
	Steel rolls not running fast enough	Increase tractor rpm
Swath not being inverted completely	Moldboard not adjusted properly	Adjust moldboard angle. The tighter angle will result in less inversion, The wider angle will give you a greater inversion.

INDEX

Air System	page 32
Axle	page 26 - 27
Bearings	page 28 -31
Chains & Sprockets	page 28 - 31
Cylinders	page 26 - 27
Hydraulics	page 26 - 27
Main Frame	page 22 - 23
Mold Board Assembly	page 33
Pickup Assembly	page 24 - 25
Roller Assemblies	page 22 - 23
Swath Spreader	page 35
Wheel Assembly	page 26 - 27
Windrower Assembly	page 34

MAIN FRAME & ROLLER ASSEMBLY

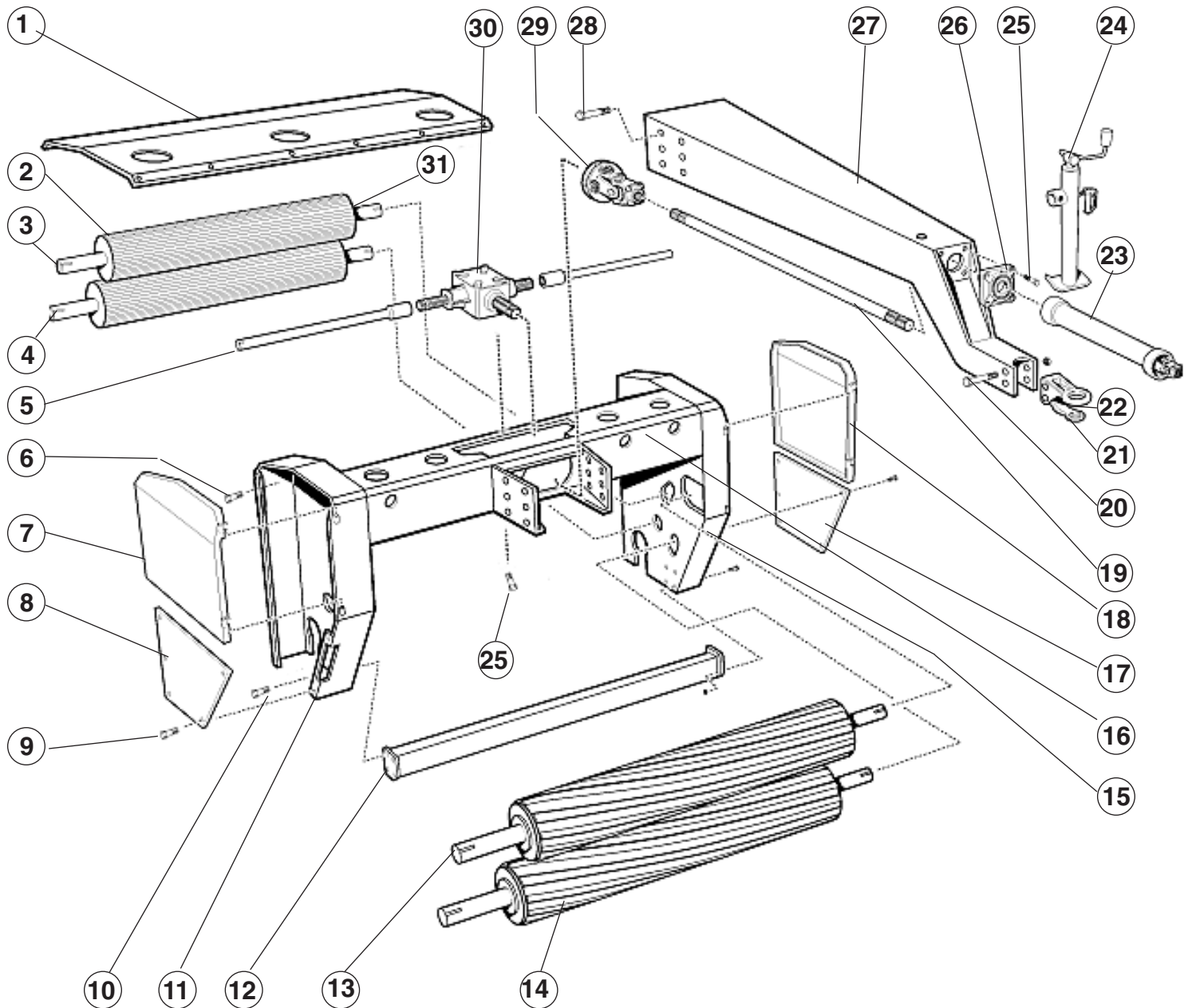

MAIN FRAME & ROLLER ASSEMBLY

Item No.	Ordering Number	No. Required	Description
1	MC241	1	Top Cover
2	MC761	1	Steel Roller Tube
3	MC761T	1	Top Steel Roller Shaft
4	MC761B	1	Bottom Steel Roller Shaft
5	MC22W7	2	Drive Stub Shaft
6	BOS28045	8	7/16 X 1" Std. Bolt
7	MC216AR	1	Door - Right hand
8	MC216R	1	Bottom side cover - Right hand
9	BOC20035	24	5/16 x 3/4" Flange Bolt
10	BOC 28045	8	7/16 x 1" Carriage Bolt and Flange Nut
11	MC21W2	1	Main Frame - right hand
12	MC21W8	1	Cylinder Cross Beam
13	MC770	1	Top Rubber Roller
14	MC771	1	Bottom Rubber Roller
15	MC21W1	1	Main Frame - Left Hand
16	MC21W3	1	Main Cross Beam
17	MC216L	1	Bottom side cover - Left hand
18	MC2168L	1	Door - Left hand
19	MC615	1	Drive Shaft
20	BOS40185	2	5/8 X 4 1/2" Bolt
21	MC631	1	Hitch clevis PP1-107 VR
22	MC630	1	Cast Hitch Top - PP1-126VR
23	MC612	1	PTO Drive Shaft
24	MC640	1	Side Wind Jack
25	BOS40065	8	5/8" X 1 1/2" Bolt
26	MC512	1	4 Bolt Flange Bearing
27	MC21W5	1	Main Frame Hitch
28	BOC40065	14	5/8 x 1 1/2" Carriage Bolt/ Nut
29	MC613	1	Friction Clutch
30	MC611	1	Gear Box
31	MC760H	4	Steel Roller Hub B-106

IMPORTANT: When ordering parts, please specify model, serial number and ordering number.

PICK UP

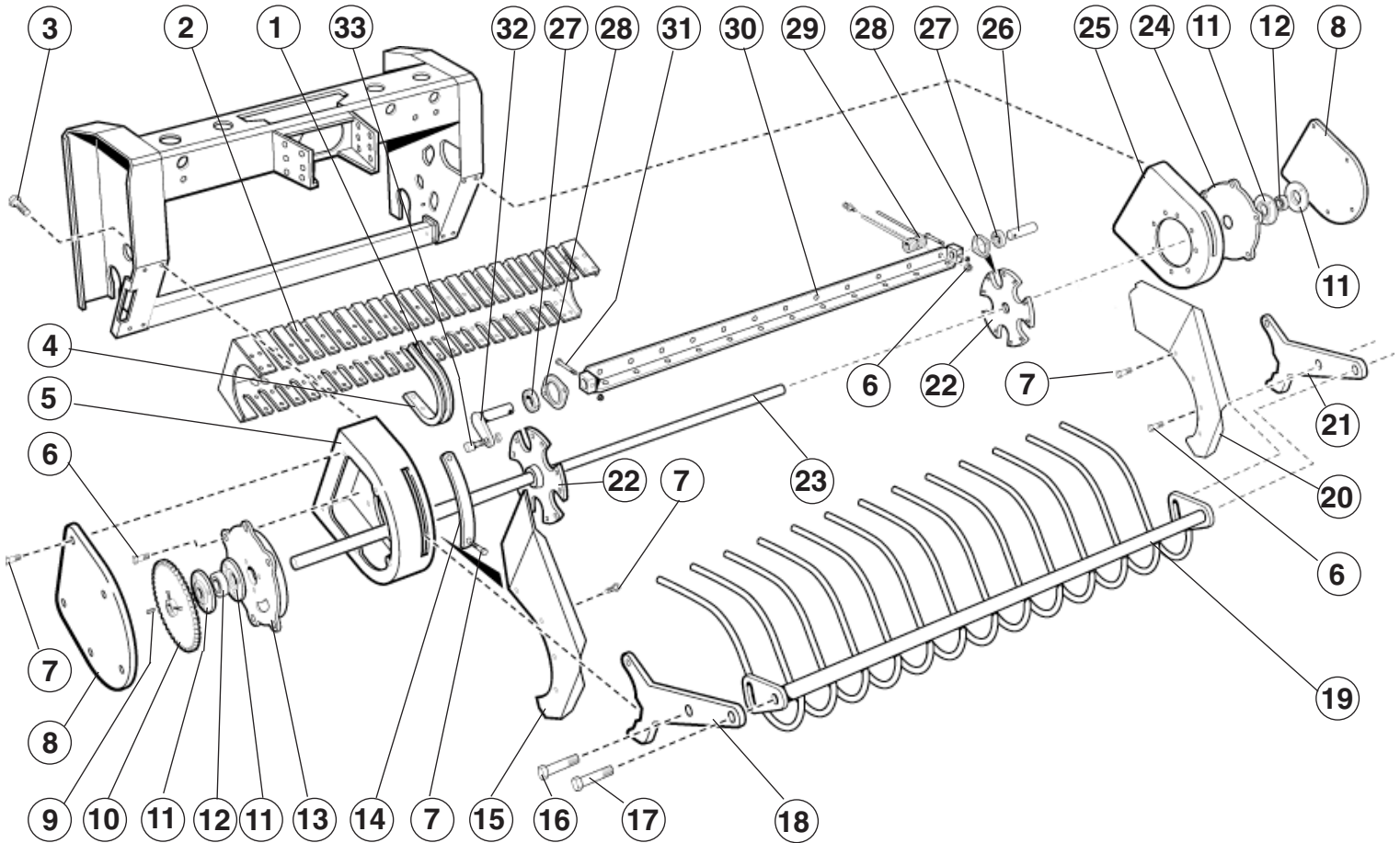

PICK UP

Item No.	Ordering Number	No. Required	Description
1	MC114	27	Pickup Wrapper
2	MC11W1	1	Pickup Crossing
3	BOF28045	8	7/16" x 1" Flange Bolt
4	MC114A	27	Pickup Wrapper spacer
5	MC11W3	1	Pickup Frame - Right hand
6	BOF24045	87	3/8" x 1" Flange Bolt
7	BOF20035	126	5/16" x 3/4" Flange Bolt
8	MC112	2	Pickup Cover
9	KE1605	3	1/4 X 1 1/4 Key
10	MC824	1	Sprocket - 60B54-1 1/4
11	MC516	4	3 Bolt Press Steel Flange
12	MC513	2	Bearing - 1 1/4" Self Aligning
13	MC122	1	Cam Track
14	MC113	1	Access Cover
15	MC115R	1	Pickup Shield - Right hand
16	BOSH40085	2	.5/8" x 1" Socket Head Cap Screw & Nut
17	BOS40045	2	5/8" x 1" Std Bolt
18	MC142	1	Comb Arm - Right hand
19	MC14W3	1	Comb
20	MC115L	1	Pickup Shield - Left hand
21	MC141	1	Comb Arm - Left hand
22	MC13W2	2	Bearing Bracket Wheel
23	MC134	1	Main Pickup Shaft
24	MC121	1	Bearing Holder Plate
25	MC11W2	1	Pickup Frame - Left hand
26	MC133A	5	Tooth Bar Shaft
27	MC514	10	1" Bearing- Self Aligning
28	MC515	20	2 Bolt Press Steel Flange
29	MC750	60	Tooth
30	MC13W1	5	Tooth Bar
31	BOSH20065	10	5/16" x 1 1/2" Socket Head Cap Screw
32	MC14W4	5	Cam Arm
33	MC51A1	5	Stud Bearing (CRSB20), Spacer & Nut

AXLE, WHEEL AND HYDRAULICS

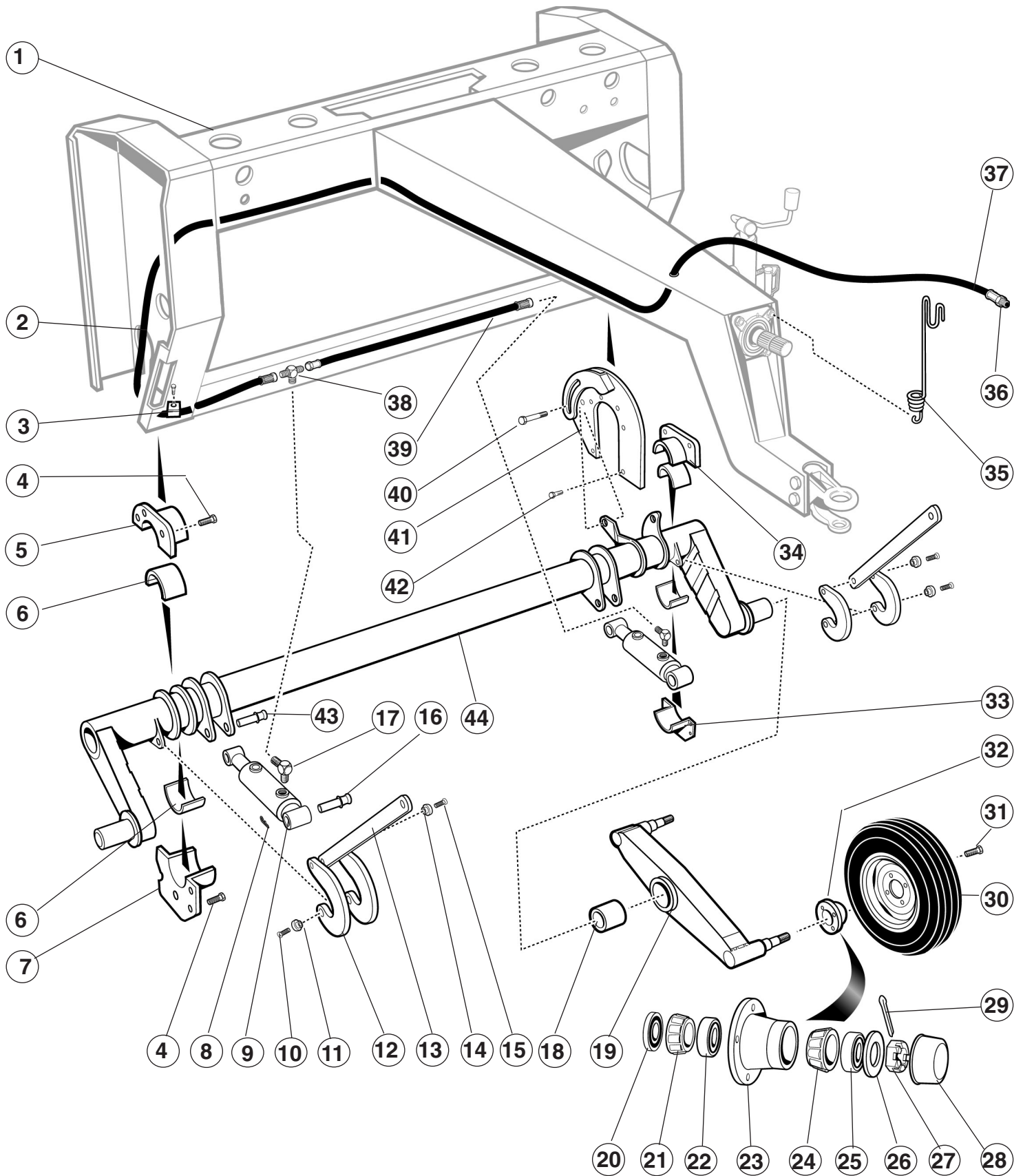

AXLE, WHEEL AND HYDRAULICS

Item No.	Ordering Number	No. Required	Description
1	MC21W3	1	Main Cross Beam
2	MC712	1	Hydraulic Hose - Long
3	MC716	1	3/8" NPT Tee
4	BOC28055	9	7/16" x 1 1/4" Carriage bolt & Flange Nut
5	MC21W7R	1	Axle Seat R/H
6	MC217	4	Axle Bushing
7	MC21W4R	1	Axle Support R/H
8	MC722	4	R Klip
9	MC711	2	Hydraulic Cylinder
10			
11	MC232M	4	Lift Bracket Bushing
12	MC232	4	Roller Lift Bracket
13	MC233	2	Roller Lift arm
14	BOC32125	6	1/2" x 3" Bolt & Nut
15	MC233M	8	Lift Arm Bushing
16	MC721	2	1" x 4 3/4" Cylinder Pin
17	MC715	1	90° Elbow
18	MC235	2	Walking Beam Bushing
19	MC23W5	2	Walking beam
20	MC552	4	Oil Seal
21	MC553	4	LM603049 Bearing
22	MC554	4	Race
23	MC551	4	Wheel Hub
24	MC556	4	Race
25	MC555	4	LM48548 Bearing
26	MC561	4	Washer
27	MC557	4	Nut
28	MC559	4	Hub Cap
29	MC558	4	Cotter Pin
30	MC550	4	Wheel, Tire And Rim
31	MC560	24	Wheel Bolt
32	MC551-9	4	Wheel Hub Assembly
33	MC21W4L	1	Axle Support L/H
34	MC21W7L	1	Axle Seat L/H
35	MC723	1	Hose Holder
36	MC718	1	Flow Restrictor
37	MC717	1	Quick Coupler
38	MC714	1	45° Elbow
39	MC713	1	Hydraulic Hose - Short
40	MC730	1	Travel Saftey Pin
41	MC21W9	1	Travel Saftey Bracket
42	BOC28065	7	7/16" x 1 1/2" Carriage Bolt / Flange Nut
43	MC720	2	1 x 3 1/2" Cylinder Pin
44	MC23W1	1	Axle
45	MC731	2	Travel Saftey Chain

LEFT SIDE

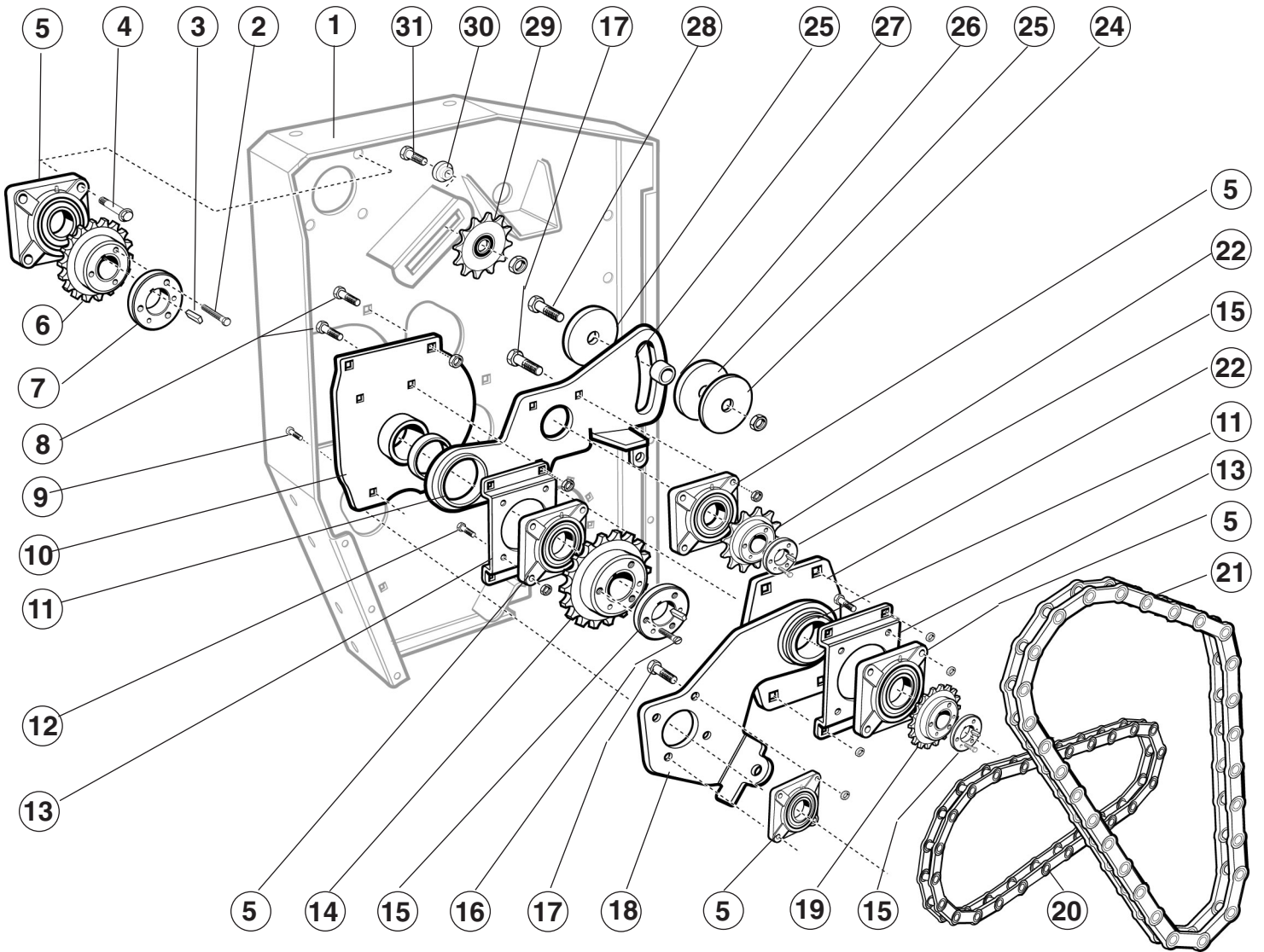

LEFT SIDE

Item No.	Ordering Number	No. Required	Description
1	MC21W1	1	Main Frame L/H Side
2	BOS24055	3	3/8 x 1 1/4" Grade 5 Bolt
3	KE 2408	4	3/8 x 2" Key
4	BOS40085	4	5/8 x 2" Std Bolt
5	MC512	5	4 Bolt Flange bearing
6	MC827	1	80 Q 21 Sprocket
7	MC815	1	Q1-1 3/4 Hub
8	BOC32045	2	1/2 x 1" Carriage Bolt/ Flange Nut
9	BOC32055	6	1/2 x 1 1/4 Carriage Bolt/ Flange Nut
10	MC22W2	1	Pivot Arm Holder
11	MC221	2	Pivot Bushing
12	BOC40065	8	5/8 x 1 1/2 Carriage Bolt/ Reg Nut
13	MC223	2	Roller Bearing Bracket
14	MC822	1	60 P 25 Sprocket
15	MC814	3	P 1-1 3/4 Hub
16	BOS20045	9	5/16 x 1" Grade 5 Bolt
17	BOC40085	8	5/8 x 2" Carriage Bolt/ Reg Nut
18	MC22W4L	1	Rubber Roller Pivot Arm L/H
19	MC826	1	80 P 14 Sprockets
20	CH6022	1	60 Chain 22 Links
21	CH8032	1	80" Chain 32 links
22	MC22w1	1	Pivot Arm Holder
23	MC821	1	60 P 16 Sprocket
24	MC225A	1	2 3/4" Washer
25	MC225	2	Guide Washer
26	MC225B	1	Spacer Pipe
27	MC22W5L	1	Steel Roller Pivot Arm L/H
28	BOC40125	1	5/8 x 3" Carriage Bolt/ Nylon Lock Nut
29	MC831	1	H 80-A12 Tentioner Sprocket
30	MC212	1	Tightner Spacer
31	BOC40105	1	5/8 x 2 1/2 Carriage Bolt/ Lock Nut

RIGHT SIDE

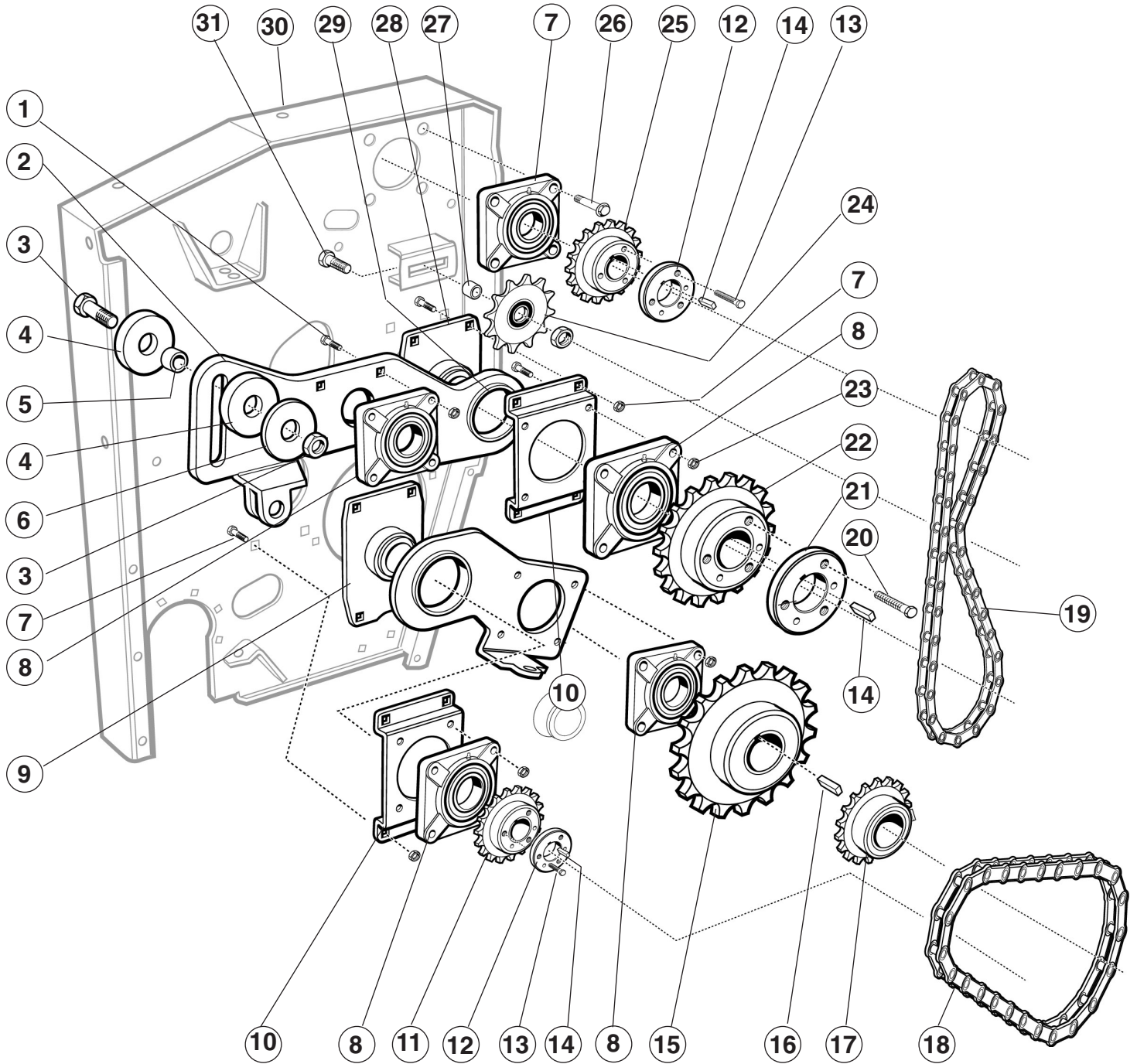

RIGHT SIDE

Item No.	Ordering Number	No. Required	Description
1	BOC0085	8	5/8 x 2" Carriage Bolt / Reg Nut
2	MC22W5R	1	Steel Roller Pivot Arm
3	BOC0125	1	5/8 x 3" Carriage Bolt / Reg Nut
4	MC225	2	Guid Washer
5	MC225B	1	Spacer Pipe
6	MC225A	1	2 3/4" Washer
7	BOC2055	8	1/2 x 1 1/4" Carriage Bolt / Flange nut
8	MC512	5	4 Bolt Flange Bearing
9	MC22W4R	1	Rubber Roller Pivot Arm R/H
10	MC223	2	Roller Bearing Bracket
11	MC820	1	60 P 13 Sprocket
12	MC814	2	P1 - 1 3/4 Hub
13	BOS20045	6	5/16 x 1" Grade 5 Bolt
14	KE2408	4	3/8 x 2" Key
15	MC823	1	60B32 - 1 3/4 Sprockets
16	KE1605	1	1/4 x 1 1/4" Key
17	MC825	1	60B11 - 1 1/4" Sprocket
18	CH6025	1	60" Chain, 23 Links
19	CH8025	1	80" Chain, 25 Links
20	BOS24055	3	3/8 x 1 1/4" Grade 5 Bolt
21	MC815	1	Q1 - 1 3/4 Hub
22	MC828	1	80 Q 23 Sprocket
23	BOC40065	8	5/8 x 1 1/2" Carriage Bolt/ Standard Nut
24	MC831	1	H-80 A 12 Tensioner Sprocket
25	MC826	1	80 P 14 Sprocket
26	BOS40085	4	5/8 x 2" Standard Bolt
27	MC2123	1	Tightener Spacer
28	MC22W1	2	Pivot Arm Holder
29	MC221	2	Pivot Bushing
30	MC21W2	1	Main Frame Right Hand Side
31	BOC40105	1	5/8 x 2 1/2" Carriage Bolt

IMPORTANT: When ordering parts, please specify model, serial number and ordering number

AIR SYSTEM

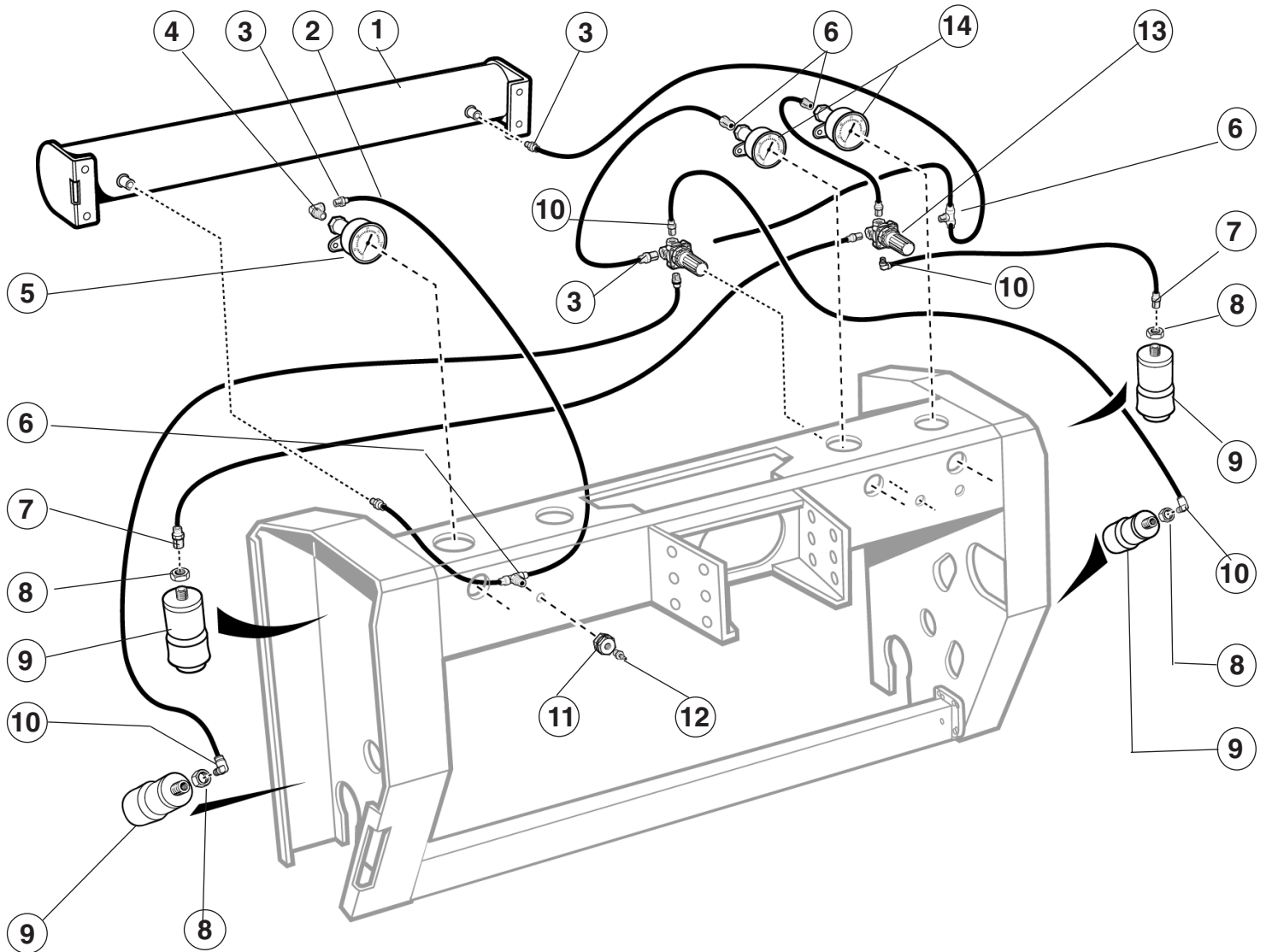

Item No.	Ordering Number	No. Required	Description
1	MC24W3	1	Air Tank
2	MC912	30'	Tubing
3	MC919	5	1/4 x 1/4" Straight Fitting
4	MC921	3	1/4" female end x 1/4" hose end Elbow
5	MC914	1	Air Tank Pressure gauge
6	MC922	2	Tee
7	MC918	2	1/8" x 1/4" Straight Fitting
8	MC923	4	3/4" Fine thread jam nut
9	MC910	4	Airbag
10	MC920	6	1/8" male x 1/4" hose end Elbow
11	MC915	1	Bulkhead Fitting
12	MC916	1	Shradar Valve
13	MC911	2	Regulator
14	MC913	2	Roller Pressure Gauge

MOLD BOARD ATTACHMENT

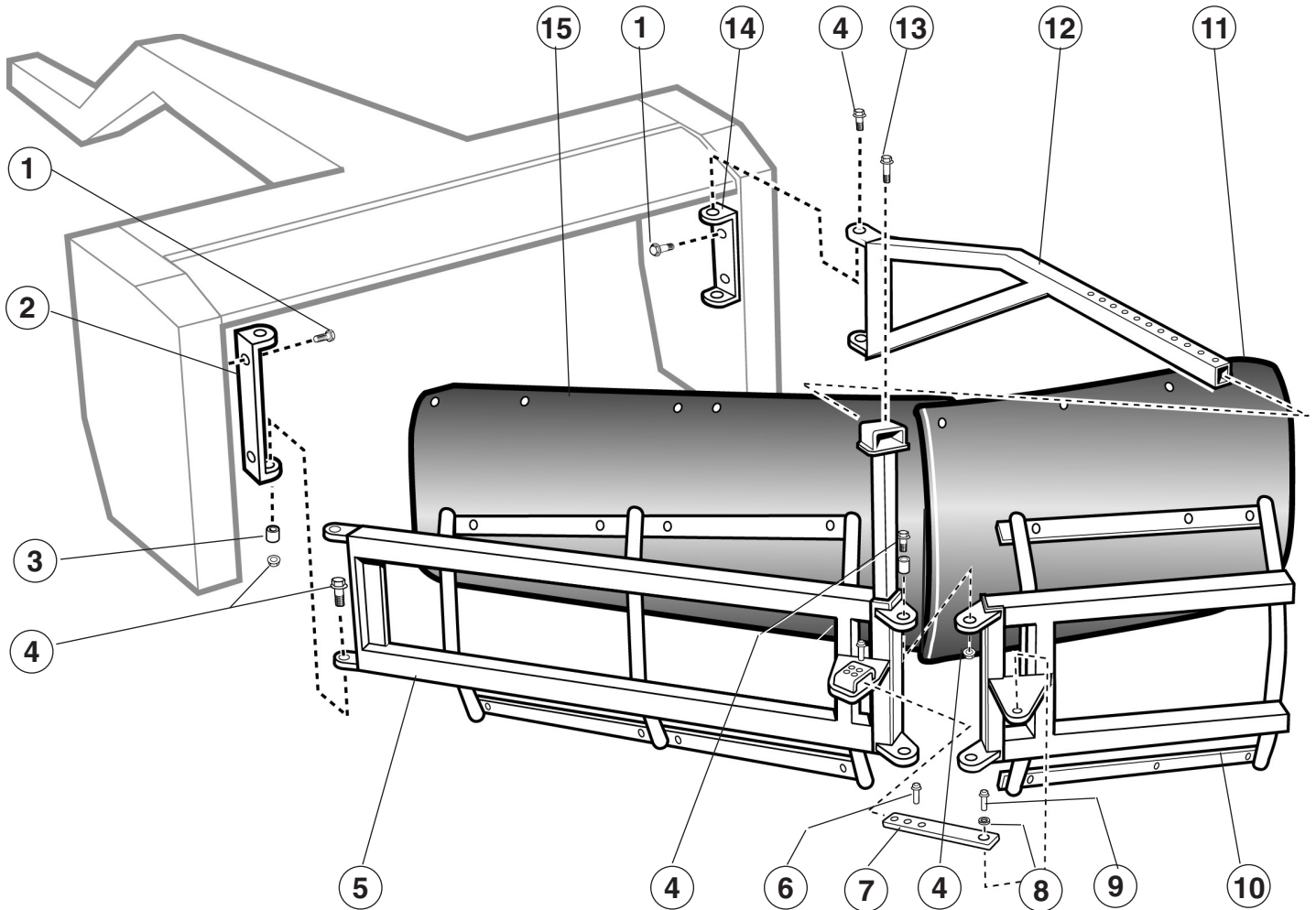

Item No.	Ordering Number	No. Required	Description
1	BOF24045	8	3/8" x 1" Flange Bolt
2	MB12W1	1	Mold Board Attachment Bracket L/H
3	MB124	6	Pivot Bushing
4	BOS32055	6	1/2" x 1 1/4 Bolt And Nut
5	MB12W3	1	Mold Board Main Frame
6	MB126P	1	Adjuster Pin 1/2" x 1 1/2"
7	MB126	1	Extension Adjuster Bar
8	MB123L	1	Bushing
9	BOS3206S	1	1/2" x 1/2" Bolt And Nut
10	MB12W4	1	Mold Board Extension Frame
11	MB122E	1	Mold Board Extension
12	MB12W5	1	Adjuster Arm
13	MB125P	1	Adjuster Pin 1/2" x 4"
14	MB12W2	1	Mold Board Attachment Bracket R/H
15	MB122	1	Mold Board

IMPORTANT: When ordering parts, please specify model, serial number and ordering number.

WINDROWER

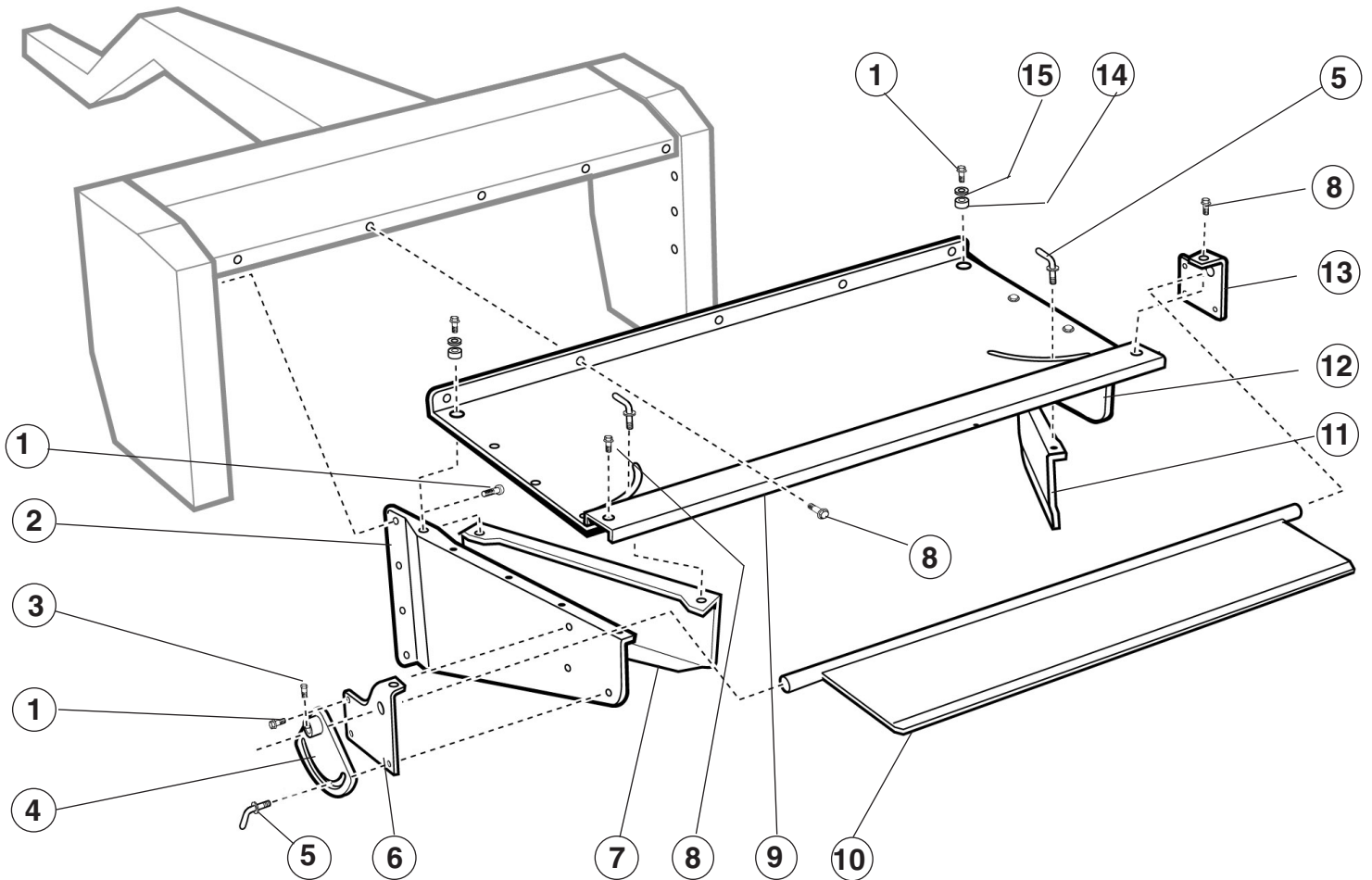

Item No.	Ordering Number	No. Required	Description
1	BOF24045	15	3/8 x 1" Flange Bolt
2	MC248A	1	Windrower Support - Left hand
3	BOSH20065	1	Socket Head Cap Screw
4	MC24W2	1	Shoot Adjuster Slide
5	MC24W8D	3	3/8" x 1" Wing Bolt
6	MC24W8	1	Shoot Adjuster Bracket - Left hand
7	MC248CL	1	Windrower Width Adjuster - Left hand
8	BOF20035	14	5/16" x 3/4" Flange Bolt
9	MC248	1	Windrower Top
10	MC24W1	1	Shoot Adjuster Plate
11	MC248CR	1	Windrower Width Adjuster - Right hand
12	MC248B	1	Windrower Support - Right hand
13	MC24W9	1	Shoot Adjuster Bracket - Right Hand
14	MC248C	2	Windrower Bushing
15	WAF28	5	Washer

SWATH SPREADER

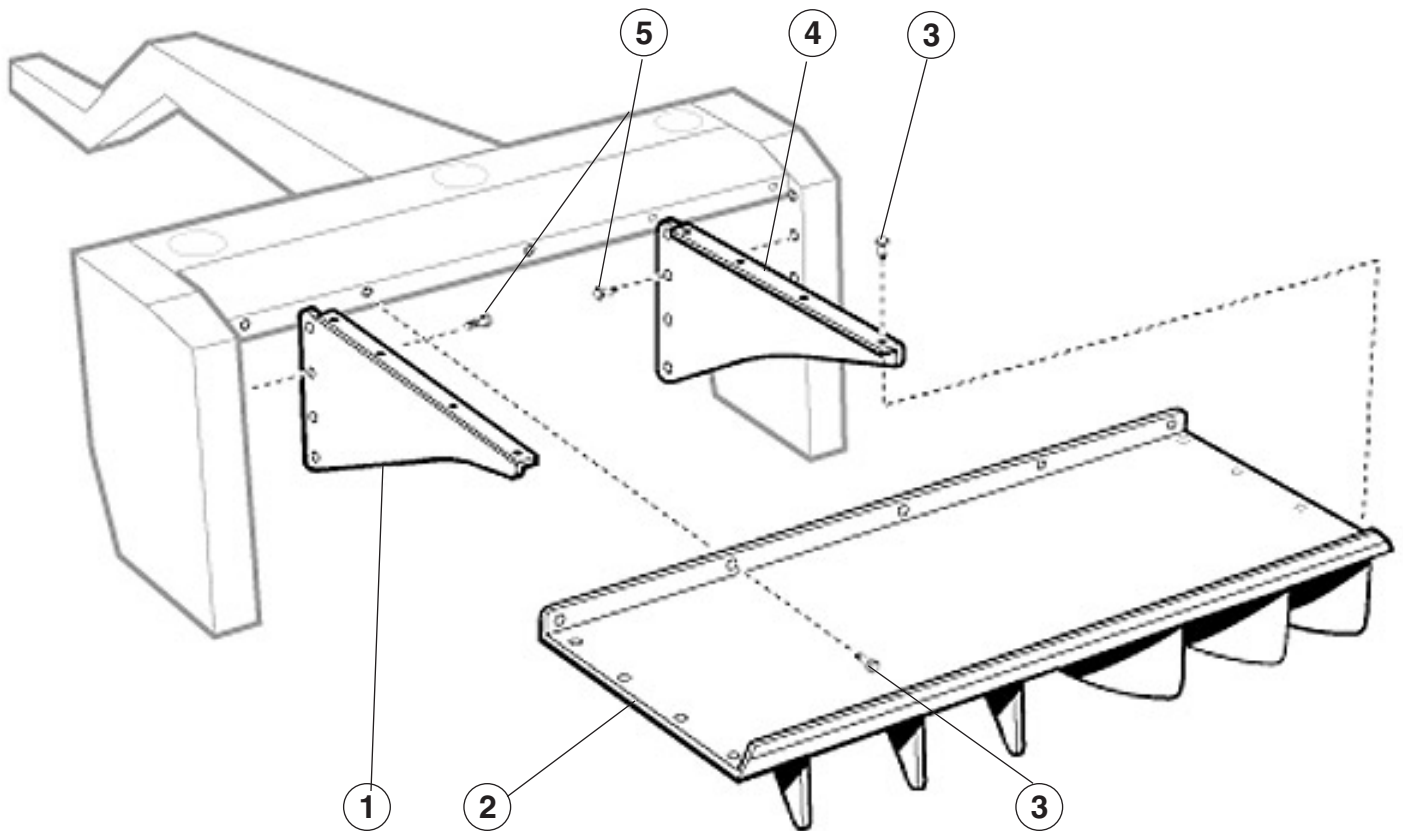

Item No.	Ordering Number	No. Required	Description
1	MC247A	1	Spreader Support L/H
2	MC24W7	1	Spreader Top
3	BOF20035	12	5/16" x 3/4" Flange Bolt
4	MC247B	1	Spreader support R/H
5	BOC24045	8	3/8" x 1" Flange Bolt

LIMITED WARRANTY

Warranty service will be performed by any AgLand Dealer authorized to sell new AgLand equipment of the type requiring service or at any AgLand Service Centre approved and authorized to service the equipment involved.

AGLAND WARRANTY

PRO-FAB manufacturers the AgLand Macerator, Pro-Fab, or authorized agent ("The Manufacturer"), warrants each item of new AgLand equipment sold by it to be free of defects in material or workmanship under normal use and service. The sole obligation of The Manufacturer to The dealer is limited to repairing or replacing, as The Manufacturer may elect, and part or parts that prove, in The Manufacturer's judgement, to be defective in material or workmanship within one year* after delivery to the original Retail purchaser under normal farm use (*3 month from date of delivery when purchased by a commercial operator). Such a defective part or parts will be replaced or repaired only to the original Retail Purchaser. Warranty repair or replacement will be done at the location of the selling AgLand Dealer. Defective parts or equipment must be returned to The Manufacturer or Approved dealer or Service location approved by The Manufacturer and at the expense of the Retail Purchaser to be inspected by The Manufacturer or its Agent. Purchaser must give written notice to the authorized dealer from whom equipment was purchased of any claimed defect, and The Dealer will have a reasonable time under the circumstances then existing to repair or replace the part or parts found to be defective. It is understood that if there is any delay in giving such written notice wherein it is possible that the alleged defect part may have caused damage or defects to other parts of the equipment, then this warranty shall not cover the repairs necessitated thereby.

NOTE: The sole remedy of The Purchaser for a claim under this warranty is the repair or replacement of defective parts

This warranty does not extend to the drive components or tires, which are made by other manufacturers and carry warranties from said manufactur-

ers. Subject to the provisions of the Agricultural Implements Act, there are no representations, warranties, or conditions, express or implied, statutory or otherwise, except those herein contained and no agreement collateral otherwise except those herein contained, and no agreement collateral hereto shall be binding upon either party unless in writing hereon or attached hereto, signed by The Purchaser and accepted by The Manufacturer at its head office.

SERVICE AND WARRANTY INFORMATION

The Manufacturer's liability under this warranty is limited to the repairing or replacing of parts only, and The Manufacturer shall in no event be liable to The Purchaser for consequential damage or loss of profits sustained by it as a result of any defect in material or workmanship on any of the equipment covered by this warranty.

AgLand equipment is warranted for agricultural use only. This warranty does not cover claims resulting from any use for other than agricultural applications.

Altering, modifying, or adding additional equipment which is not approved for installation on Agland equipment by The Manufacturer will void this warranty.

All warranties are subject to legislation of the state or province in which the equipment is sold.

NOTE: There are no warranties, express or implied, by the Manufacturer or its Authorized Dealer regarding AgLand equipment except the warranty against defects in the material or workmanship expressed herein. No person is authorized to bind The Manufacturer to any other warranty whatsoever.

The Manufacturer reserves the right at any time to make changes in the design, material, or specifications of equipment or parts without thereby becoming liable to make similar changes in equipment, machinery, or parts previously manufactured.

Agland

Pro-Fab