

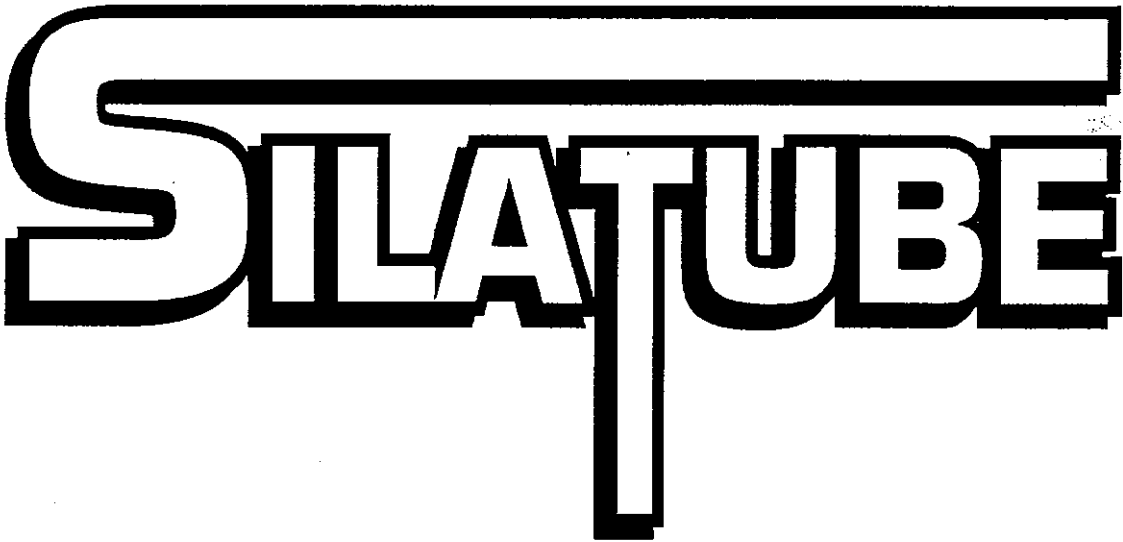

**OWNER'S
MANUAL**



Models

P-6200 & P-6300

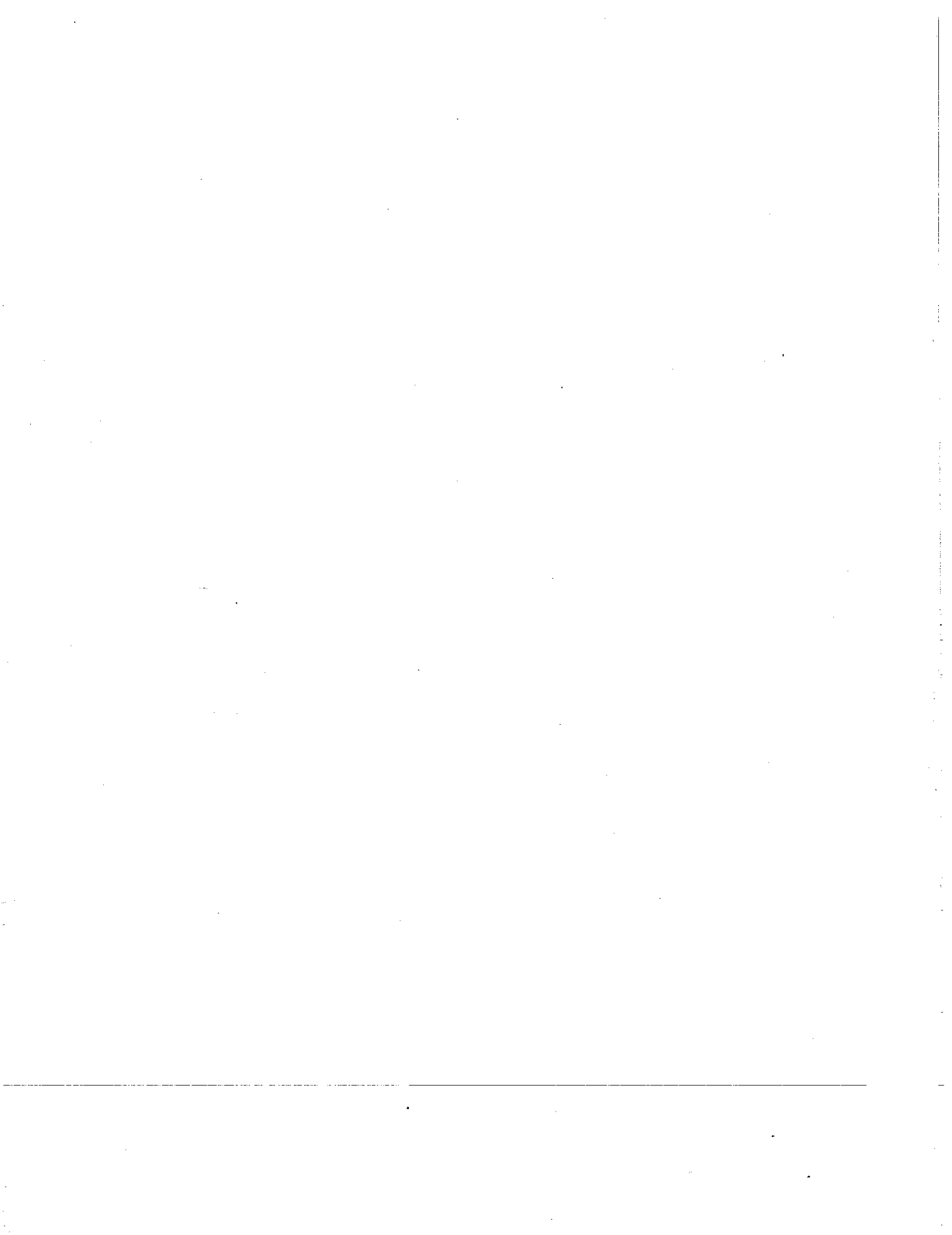

TABLE OF CONTENTS

Section	Item	Page
1	Introduction	5
2	Safety	6
	General Safety	6
	Safety in Operation	6
	Safety with Maintenance	7
	Safety in Transport	7
	Safety in Storage	7
3	Decals	8
	Safety Decals	8
	Maintenance Decals	9
4	Start-up	10
	Basic Start-up Procedures	10
	Ground Preparation	11
	Adjustments of SilaTube	11
	Installation of Tube	13
	Operation	15
	Steering the SilaTube	17
5	Maintenance	18
6	Storage	19
7	Specifications	20
8	Parts List	21
	SilaTube P-6200 Assembly	21
	SilaTube P-6300 Assembly	24
	Detail of Arch Model P-6200	27
	Detail of Arch Model P-6300	28
	Automatic System Detail	29
	Arch Cylinder P-6200	30
	Arch cylinder P-6300	31
	Pusher Cylinder # 20G72	32
	6 Spool Control Valve # 32111	33
	1 Spool Control Valve (SD4 standard) # 32138	34
	1 Spool Control Valve (SD4 modified) # 32110	35
	Engine Assembly with Pump	36
	Front Hub H1000	37
	Rear Hub H511	38
	Hydraulic System	39
	Hydraulic steering option	42
9	Torque Chart	43
10	Warranty	44

INTRODUCTION

1

CONGRATULATIONS!

Thank you for choosing PRONOVOST. We are confident this equipment will meet your requirements in terms of quality, performance and reliability.

This manual was prepared to assist you in the safe operation of your new SilaTube. It contains important information which will help you achieve excellent returns with your tubing-machine for years to come.

Please read this manual completely before operating your SilaTube and keep it for future reference.

Before starting the machine, you or any other person who will be operating the SilaTube must familiarize yourself with the safety recommendations and the operating instructions. Please read carefully and be sure to understand and follow all recommendations and procedures.

In this manual, the right and left sides of the SilaTube are identified while standing at the discharge end of the machine and facing it.

If you require additional information on your SilaTube, please contact your PRONOVOST Dealer.

NOW take a moment to enter the model, serial number and the date of purchase of your SilaTube in the space provided.

When ordering parts from your Dealer, please refer to these numbers for a fast and efficient service. Use PRONOVOST parts for replacement.

The model and serial numbers are on the nameplate shown on Fig. 1.

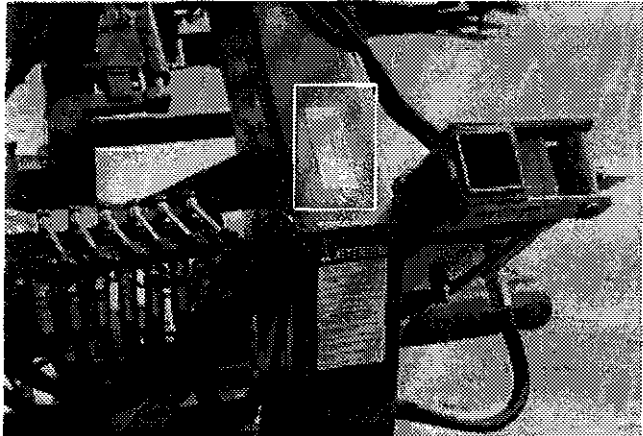

Figure 1

MODEL: _____

SERIAL NO.: _____

DATE OF PURCHASE: _____

SAFETY

GENERAL SAFETY

2

WHEN YOU SEE THIS SYMBOL



ATTENTION!

**BE ALERT
YOUR SAFETY IS INVOLVED**

This symbol «**SAFETY ALERT**» is used in this manual and on the safety decals on the SilaTube. It warns you of the possibility of danger. Carefully read, understand and follow all safety recommendations before operating the SilaTube.

- 1) Careful operation is the best assurance against accidents. Carefully read this manual and the motor manual and follow all recommendations before operating your SilaTube. It is the owner's responsibility to make sure that anyone who will operate the SilaTube will read these manuals before operating the equipment.
- 2) Never let a child operate the SilaTube.
- 3) Do not modify the SilaTube. Any non authorized modification may affect the efficiency and/or safety of the equipment.
- 4) Never operate the SilaTube with defective parts or if damaged in any way. Have it repaired before operating.
- 5) Make sure all fasteners are in place and properly secured or tightened. Refer to torque chart on page 43.
- 6) Avoid wearing loose fitting clothing when working with the SilaTube. These could get entangled in moving parts of the equipment and cause accidents.
- 7) Keep motor clean and exempt of dust and debris.
- 8) Before using the SilaTube, inspect the area where it is to be used and remove any object which could hamper normal operation or damage the plastic tube.
- 9) Hydraulic fluids under pressure can damage your skin. Do not use your hands to locate a leak.
- 10) Plastic bags are impervious to air. Keep them away from children to avoid suffocation.
- 11) When using a tractor equipped with a spear, be extremely careful. Always lower the spear to the ground before leaving your tractor.
- 12) Do not store, spill or use fuel near a flame, a hot engine or stove.

SAFETY IN OPERATION

- 1) Be sure there are no obstructions around the equipment and that no one stands near the SilaTube when in operation.
- 2) Always refuel equipment when outside and away from flames or sparks.
- 3) Never run the engine inside. Do not operate the engine in a confined or non ventilated area. Carbon monoxide is a colorless, odorless and deadly gas.
- 4) Be careful when adjusting equipment with engine running.

SAFETY (cont'd)

- 5) Keep hands, feet, hair and clothing away from moving parts.
- 6) Should you need to step on the SilaTube for whatever reasons, **ALWAYS** disengage the pusher valve trigger mechanism since there is **RISK OF CRUSHING** if not disengaged.
- 7) Do not refill fuel tank with engine running. Always let the engine cool off for a couple of minutes before refilling. Always use approved fuel containers.
- 8) Do not operate the engine if fuel is spilled. Move equipment away from the spill and avoid any spark until the complete evaporation of the fuel.
- 9) Do not smoke while refueling.
- 10) Do not operate engine with any accumulation of hay, leaves, dirt or any other combustible material near the exhaust muffler.
- 11) Avoid touching the hot muffler and cooling fins since they could cause burns to your skin.

SAFETY WITH MAINTENANCE

- 1) Perform the SilaTube maintenance according to the recommendations contained in this manual.
- 2) Stop engine and relieve all hydraulic pressures before doing inspection, maintenance or repairs.
- 3) Do not check spark with spark plug or wire removed. Use the appropriate testing equipment.
- 4) Regularly check fuel lines and fittings for leaks. Replace if necessary.

SAFETY IN TRANSPORT

- 1) Be sure to engage the two safety locks (A Figure 2) provided for the rear wheels hydraulic cylinders (B Figure 2).
- 2) Check local regulations for the transport of your SilaTube on the road.
- 3) Be alert when pulling the SilaTube on the road. Do not allow anyone to stand on it while in motion.
- 4) The road speed should be such as to maintain full control over steering and braking.
- 5) Be careful while backing up.

SAFETY IN STORAGE

- 1) Let engine cool and drain fuel from tank.
- 2) Do not let children play in the area where the SilaTube is stored.
- 3) Do not leave a ProTube installed on the SilaTube.
- 4) Do not let the SilaTube stand on the tires. Lower it to the ground or on wooden blocks. **THIS WILL AVOID ANY ACCIDENTAL CRUSHING OF ANIMALS OR ANYONE WHO COULD CRAWL UNDER THE EQUIPMENT.**

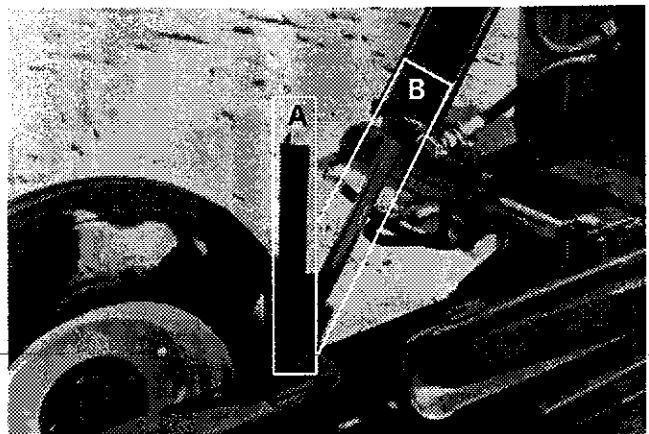

Figure 2

DECALS

SAFETY DECALS

The safety decals are affixed wherever special safety precautions are indicated. Locate them on the machine and read them carefully. If a decal is damaged, lost or illegible, install a new one. Each decal is identified with a letter and part number. The following photos indicate where each one must be installed.

3

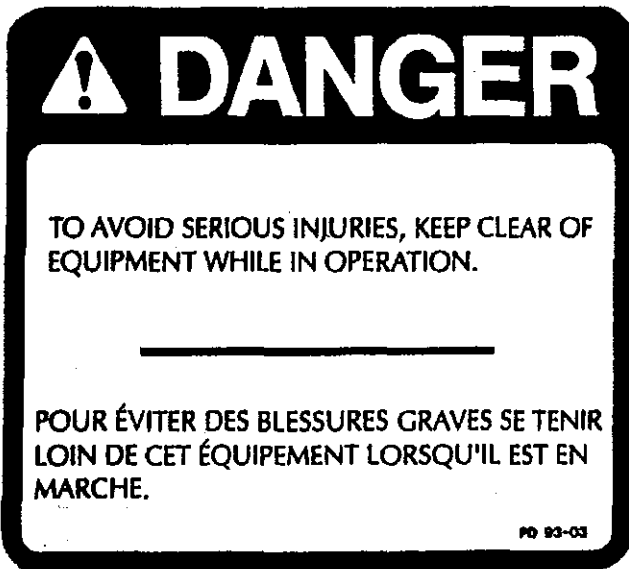

Figure 3
Decal A

Part no.: A101

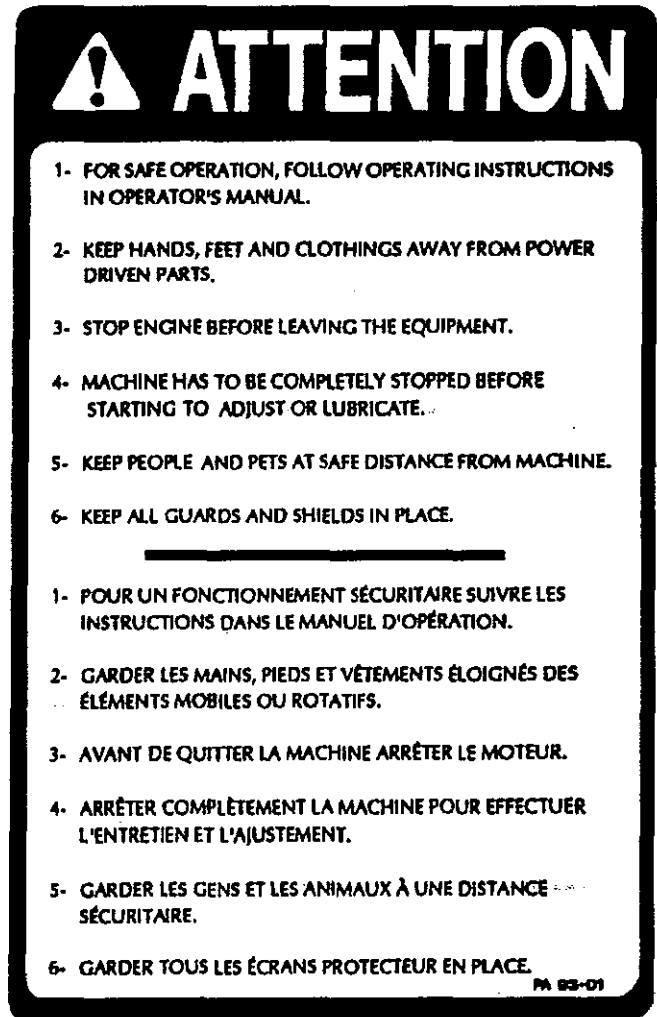

Figure 5
Decal B

Part no.: A102



Figure 4

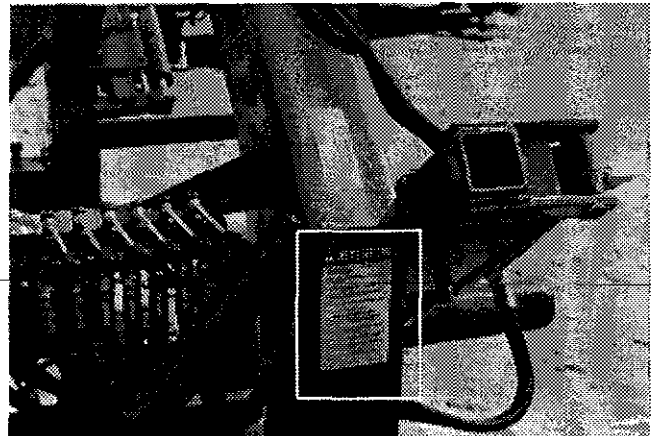

Figure 6

DECALS (cont'd)



Figure 7
Decal C

Part no.: A103



Figure 8

MAINTENANCE DECALS

The maintenance decals indicate the points requiring lubrication. Refer to the maintenance section for more details.



Figure 9

Part no.: A104

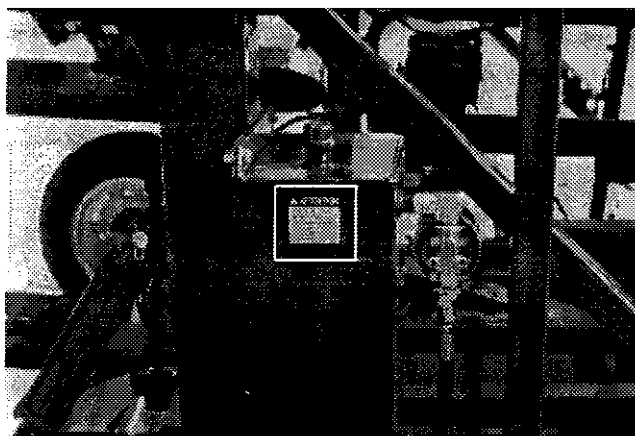

Figure 10

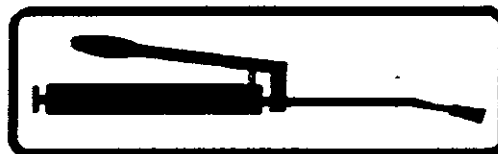

Figure 11

Part no.: A 106

STARTING-UP



4 Figure 12

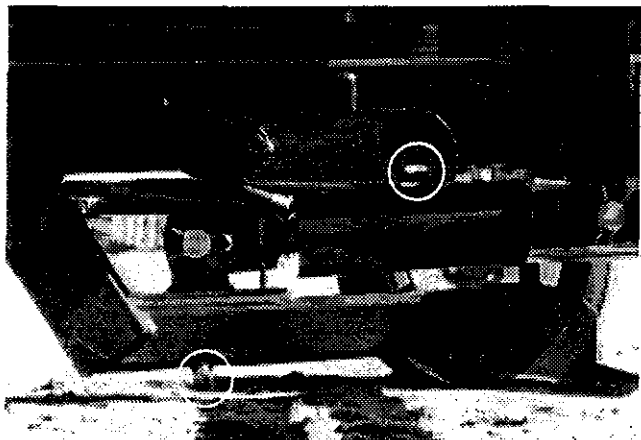

Figure 13

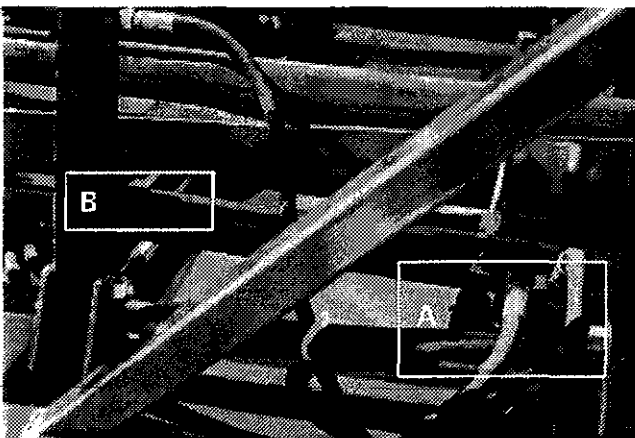

Figure 14

BASIC START-UP PROCEDURES

STEP 1 APPLIES ONLY TO THE P-6300.

- 1) Please note, for shipment, the engine is temporarily mounted in the transport position in order not to exceed the legal width allowed on the road. Consequently, it must be re-positioned properly before starting. (Fig. 12)
- 2) Do not forget to unlock the hydraulic jack before lowering and always lock it when in the retracted position. (Fig. 13)
- 3) Verify for adequate tightness of all fastening devices. Refer to torque chart on page 43.
- 4) Lubricate all points and guide mechanisms requiring grease, with a high quality lithium base grease containing molybdenum disulfide (MoS_2) such as «Esso Unirex EP1 Moly», «DARINA XL-Multi Season Moly, Grade #1» from Shell or equivalent.
- 5) Check oil level in hydraulic reservoir. Use good quality tractor transmission and hydraulic system oil such as «Trans Hydraulic Duratran» from Petro Canada, «DONAX TD» from Shell or equivalent.
- 6) Check tire pressure and adjust according to recommendation indicated on the tires.
- 7) Check engine oil level.
- 8) Check the operation of all hydraulic cylinders.
- 9) Check the operation of the bale pusher mechanism. It must operate freely and return to its starting position automatically. Should the valve (A Fig. 14) not engage positively, adjust the rod end clevis (B Fig. 14).

STARTING-UP (cont'd)

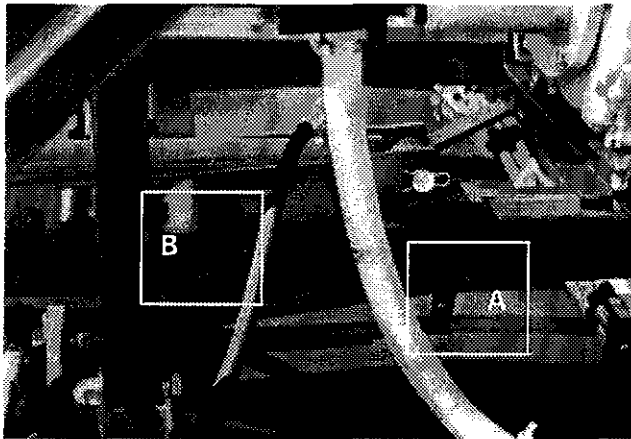

Figure 15



Figure 16

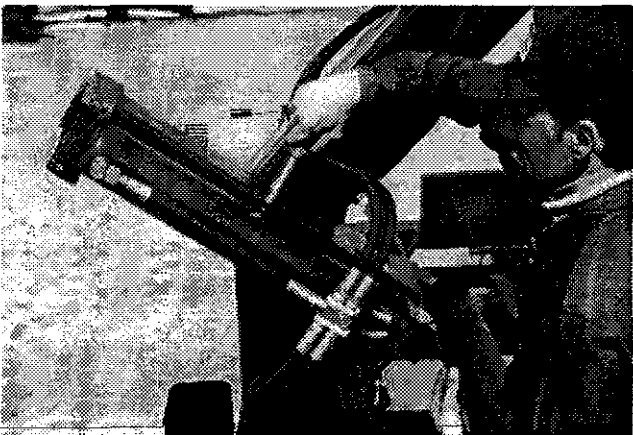

Figure 17

10) Check and if necessary, adjust the length of travel of the pusher by changing the position of lug "A" figure 15. To prevent bottoming of the piston, always keep $\frac{1}{2}$ " to $\frac{3}{4}$ " of travel at either end of the cylinders. The retracted position is adjusted in the same manner with lug "B" figure 15.

11) Check the surface of the stretcher arms for smoothness. Any mark or protrusion could cause tears to the ProTube.

GROUND PREPARATION

- 1) Choose a dry and well drained area.
- 2) Level and clean up site where the tubes will be used.
- 3) If possible, provide a sand bed of 2" to 3" (5-8 cm.) thick. This will help reduce damage from rodents.

ADJUSTMENT OF SILATUBE

STEP 1 APPLIES ONLY TO THE P-6300

- 1) Position the six (6) stretcher hydraulic cylinder assemblies according to the size of ProTube used. Use the inside holes for 4 ft. tubes, 48" to 56" (1.22 to 1.42 m) (Fig.16). Use the outside holes for 5 ft. tubes, 56" to 66" (1.42 to 1.68 m) (Fig.17).
- 2) Locate the rear end of the SilaTube approximately 5' (1.5m) away from the point where you want to position the end of the tube. This will compensate if there is some slippage of the first couple of bales until there is enough ground friction to push the SilaTube forward.

4

STARTING-UP (cont'd)

4

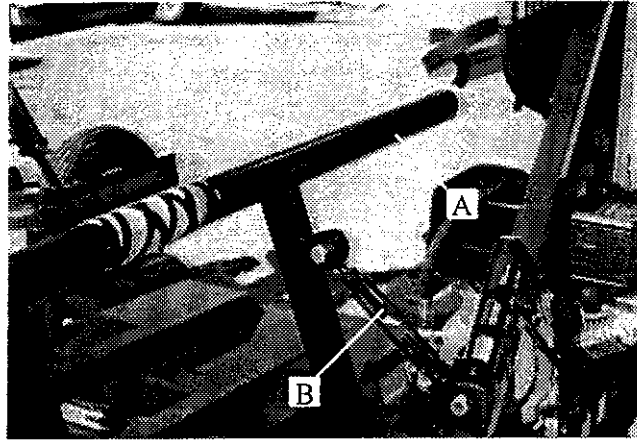

Figure 18

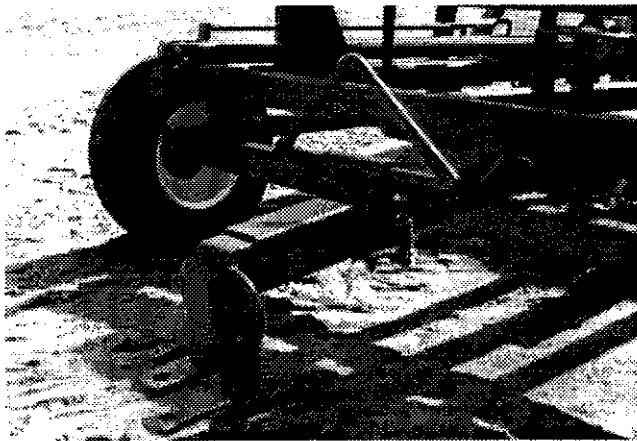

Figure 19

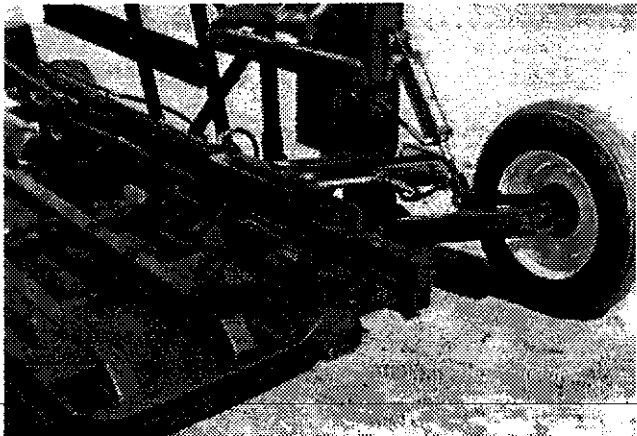

Figure 20

- 3) Adjust guides (A Fig.18) according to the width of the bales. Use turnbuckles provided (B Fig.18).
- 4) Adjust tongue to its most inward position. If there is a risk of interference with the front of the tractor or with uneven ground, it is recommended to remove it. (Fig. 19)
- 5) Adjust rear wheels in order to have a minimum amount of ground friction with the rear end of the SilaTube (Fig. 20) while keeping it in contact with the ground.
- 6) For maximum operating speed, you may set the engine to full throttle, although it is preferable to run it a speed closer to your rate of bale supply to machine. This will result in a more economical operation.

STARTING-UP (cont'd)

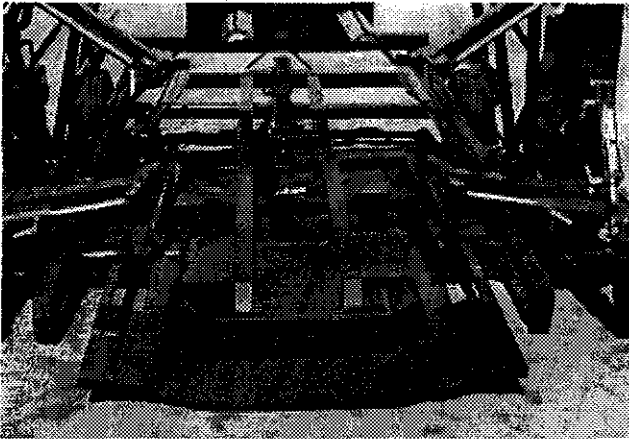

Figure 21



Figure 22



Figure 23

INSTALLATION OF THE PROTUBE

To facilitate this procedure, adhere to the following sequence:

- 1) Start engine.
- 2) Close the stretcher arms to the most inward position and pull out the tube support plate. (Fig. 21)
- 3) Install tube on the stretcher arms. Place it so that the name ProTube is facing outside when it unfolds. Slide it carefully **to the bottom** of the stretcher arms and between the two bottom plates, being careful to remove all wrinkles, since they could cause some tearing of the tube. (Fig. 22)
- 4) At this stage, apply a **SLIGHT AMOUNT OF TENSION** to the tube.
P-6200: Open each pair of stretcher arms until the end of the internal square tubing reaches the pilot hole of the outer tube. (Fig. 23)
P-6300: Open each pair of stretcher arms until the pilot hole in the square tubing reaches the lower end of the guide tube. (Fig. 24)
- 5) Do not forget to fully retract the tube support plate until it is locked in place. (Fig. 25)

4

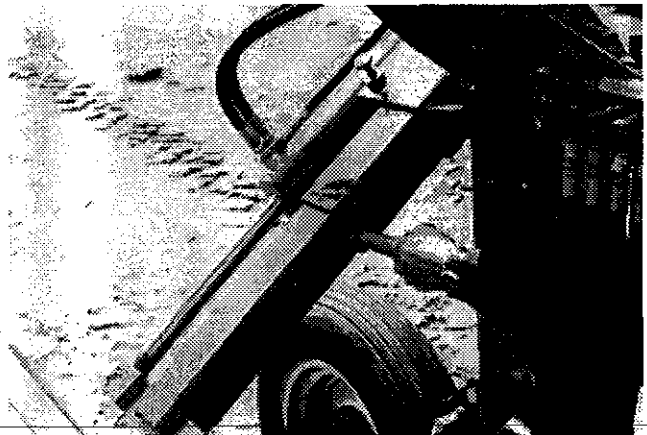
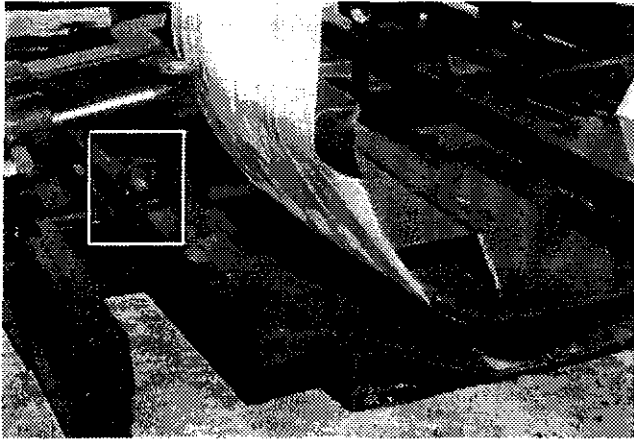

Figure 24

STARTING-UP (cont'd)



4 Figure 25

- 6) Again check the tube position (Fig. 26) and eliminate any wrinkles. Next, cut off all ties (Fig. 27).
- 7) Now it's time to close the end of the tube. Pull out the outer ply for approximately 36" (91 cm) and tie properly. (Fig. 28 and Fig. 29)
- 8) **STRETCH THE TUBE ONLY WHEN READY TO OPERATE.** It may lose some of its memory if kept stretched for too long a period of time. If you must stop loading bales for a while, **BRING THE TUBE DOWN TO A MODERATE TENSION.**



Figure 26

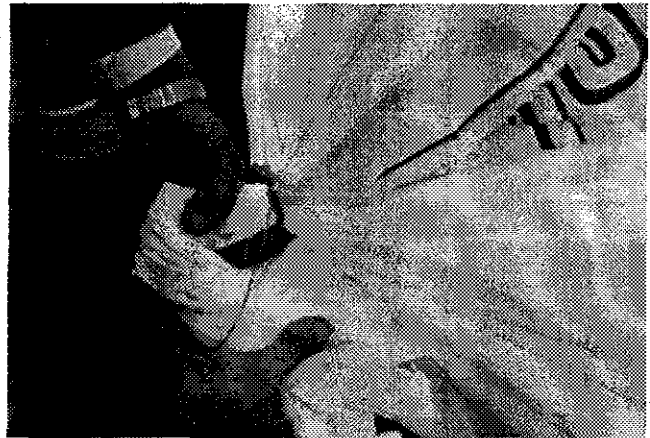

Figure 28



Figure 27

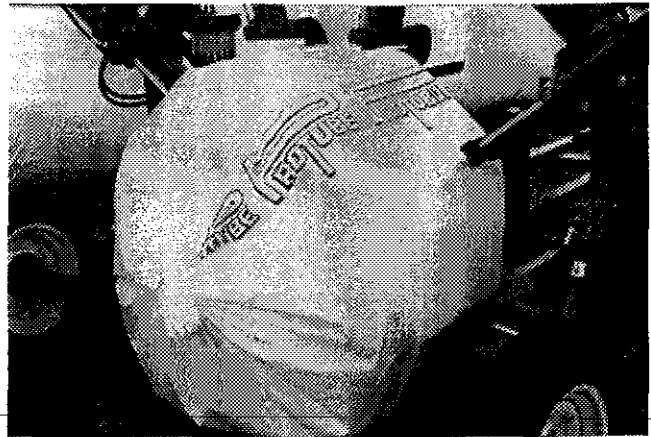

Figure 29

STARTING-UP (cont'd)



Figure 30

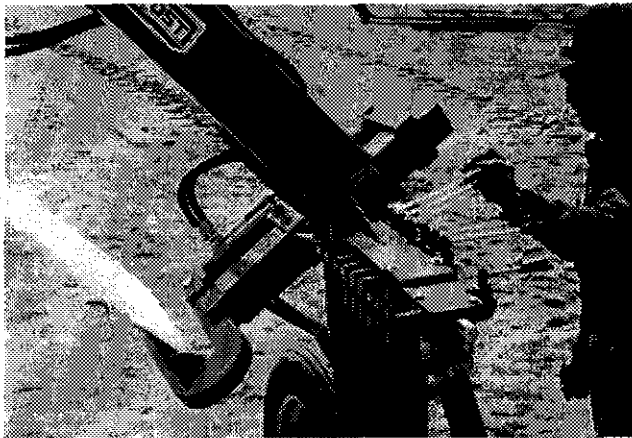

Figure 31

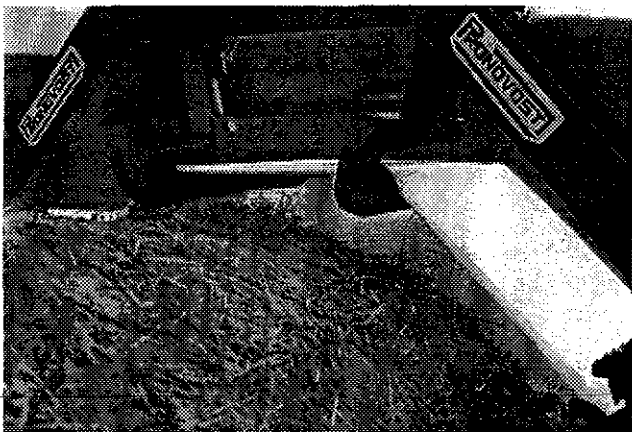

Figure 32

OPERATION

- 1) Before loading the first bale, disengage the pusher control valve by flipping the safety lock outward. (Fig. 30) Load the first bale on the machine, operate the control valve manually until the bale approaches the arms and stop it there.
- 2) Stretch the tube by operating the three valves **SIMULTANEOUSLY** (Fig. 31) to obtain a **CLEARANCE OF APPROXIMATELY 2" to 3"** between the bale and the tube (Fig. 32). Readjust stretcher arms individually if necessary.
- 3) At this point, check again the rear wheels adjustment for **minimum** ground friction (step 5, page 12) before engaging the bale pusher valve.
- 4) Reset the safety lock by pushing it fully inward. Engage the valve manually to complete the cycle automatically.
- 5) It is recommended to use a spear (single or double) on your loader to drop the bales onto the SilaTube.
- 6) Once the bale is dropped, back up immediately to make room for the SilaTube's forward movement.
- 7) After the first 3 or 4 bales, lower the rear of the SilaTube to increase ground friction. This will ensure that the bales will be real tight against each other in the Protube.
- 8) Towards the end of the tube, keep at least 36" (91 cm) of plastic, in order to allow for proper closure of the tube.

4

STARTING-UP (cont'd)

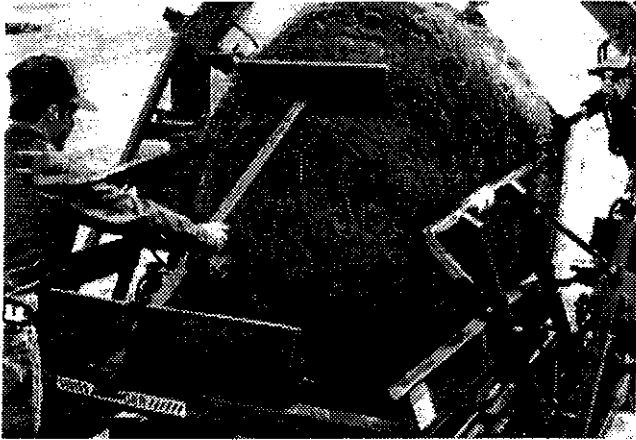

4 Figure 33



Figure 34

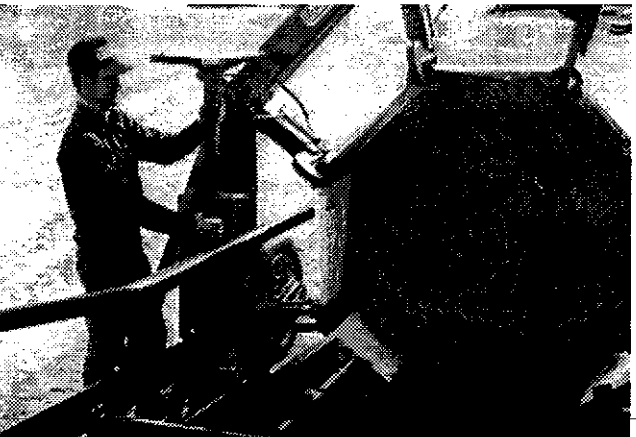

Figure 35

- 9) To push the last bale into the tube, install the pusher extension supplied with the SilaTube. (Fig. 33)
- 10) Manually engage the pusher valve to initiate the last bale cycle. (Fig. 34)
- 11) Remove the pusher extension and store it in it's receptacle on the right hand side of the SilaTube. (Fig. 35)
- 12) Close up end of ProTube as previously described. (Fig. 28 & Fig. 29)
- 13) Regularly inspect the ProTubes. If torn or punctured, repair openings with proper means.

STARTING-UP (cont'd)

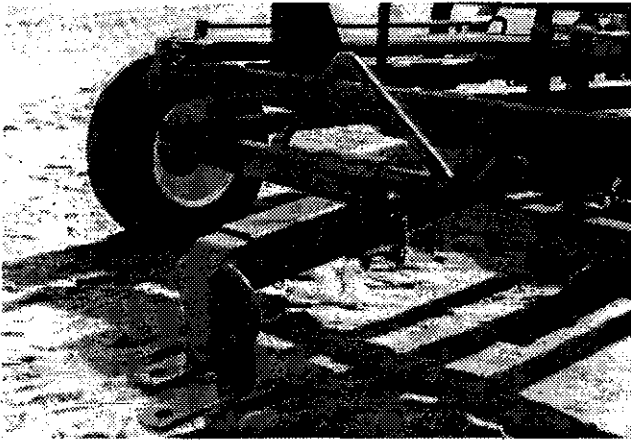

Figure 36

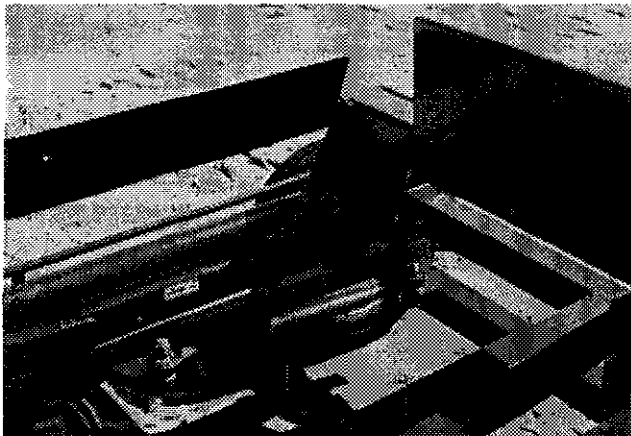

Figure 37

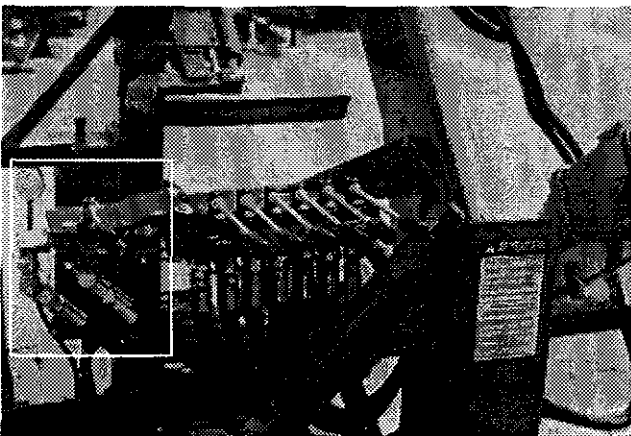

Figure 38

STEERING THE SILATUBE

- 1) A triangular shape hoop has been installed on the fixed section of the tongue (Fig. 36). This provides a quick and efficient method to influence or change the direction of travel of the SilaTube without leaving the tractor. Simply insert the bale spear in the lower part of the triangle on the side you wish to shift the SilaTube and lift slightly.
- 2) If the SilaTube has a tendency to always turn on the same side, you may adjust the direction of the wheels with the help of turnbuckles. (Fig. 37)
- 3) A hydraulic steering control mechanism is also available as an option, in this case, an additional control valve (Fig. 38) and an additional cylinder (2.5" x 8" stroke) are required (Fig. 39).

4



Figure 39

MAINTENANCE

- 1) Refer to the manufacturer's instructions for the engine.
- 2) Use a high quality lithium base grease containing molybdenum disulfide (MoS₂) such as «Esso Unirex EP1 Moly», «DARINA XL-Multi Season Moly, Grade #1» from Shell or equivalent.
- 3) Wipe off all grease fittings with a clean cloth before adding grease in order to avoid injecting dirt or sand.
- 4) Repair or replace damaged grease fittings.
- 5) Lubricate long pusher guides every 8 hours of operation.
- 5** 6) Lubricate stretcher arms guides every 20 hours of operation.
- 7) Lubricate all grease fittings every 20 hours of operation.
- 8) Open, clean and lubricate wheel bearings once a year.
- 9) Check oil level in hydraulic reservoir every 20 hours of operation. If necessary add good quality trans hydraulic oil such as «Trans Hydraulic Duratran» from Petro-Canada, «DONAX TD» from Shell or equivalent.
- 10) Change oil filter after the first 50 hours of operation and then every 250 hours. Use replacement filter no. K-22001, PRONOVOST part No. 32007.
- 11) Check all nuts and bolts once a year. If necessary use torque chart on page 43.
- 12) Check all bolts on wheels after first 5 hours of operation and then every 50 hours.
- 13) Check tire pressure every 50 hours. Adjust according to manufacturer's recommendation indicated on the tires.

STORAGE

- 1) Store the SilaTube in a cool, dry place.
- 2) Lower the SilaTube frame on wooden blocks.
- 3) Keep tires off the ground and cover them if left exposed to the sun.
- 4) Keep all piston rods in the retracted position. This will assure better protection against the elements.
- 5) Clean your SilaTube.
- 6) Touch-up or repaint if necessary.
- 7) Lubricate all points before storage.
- 8) Drain all fuel from tank and follow engine manufacturer's storage recommendations.

SPECIFICATIONS

P-6200

Overall length:	165" (4.19 m) (without the 8½" (21.6 cm) tongue)
Overall width:	100" (2.54 m)
Height:	92" (2.34 m) (transport position)
Bale diameter:	48" to 56" (1.22 to 1.42 m) diameter
Engine:	B/S 9 HP
Starting:	Manual
Two stage hydraulic pump:	3 gal at 2500 psi / 11 gal at 1100 psi
Front hub:	cap. 1000 pounds (450 kg) 4 bolts
Rear hub:	cap. 1800 pounds (810 kg) 5 bolts
Front rim:	10" x 8" - 4 bolts
Rear rim:	15" x 6" - 5 bolts
Front tires:	20.5" x 8" - 4 ply (with tube)
Rear tires:	6.7" x 15" - 4 ply (without tube)
Capacity:	100 bales per hour (Best conditions and experienced operator)
Oil tank capacity:	5.75 gal US (4.75 gal imp.) (21.75 liters)
Plastic tubes used:	ProTube 0.004 mil., 150' (47.72 m) length No. P-62204 for bale 48" to 56" (1.22 to 1.42 m) diameter
Weight on tongue:	1360 pounds (612 kg) app.
Total weight:	3900 pounds (1755 kg) app.

P-6300

Overall length:	165" (4.19 m) (without the 8½" (21.6 cm) tongue)
Overall width:	112" (2.85 m)
Overall width:	104" (2.64 m) (motor in transport position & without tires)
Height:	93" (2.36 m) (transport position)
Bale diameter:	48" to 66" (1.22 to 1.68 m) diameter
Engine:	B/S 9 HP
Starting:	Manual
Two stage hydraulic pump:	3 gal at 2500 psi / 11 gal at 1100 psi
Front hub:	cap. 1000 pounds (450 kg) 4 bolts
Rear hub:	cap. 1800 pounds (810 kg) 5 bolts
Front rim:	10" x 8" - 4 bolts
Rear rim:	15" x 6" - 5 bolts
Front tires:	20.5" x 8" - 4 ply (with tube)
Rear tires:	6.7" x 15" - 4 ply (without tube)
Capacity:	100 bales per hour (Best conditions and experimented operator)
Oil tank capacity:	5.75 gal US (4.75 gal imp) (21.75 liters)
Plastic tubes used:	ProTube 0.004 mil., 150' (47.72 m) length No. P-62204 for bales 48" to 56" (1.22 to 1.42 m) diameter No. P-62205 for bales 56" to 66" (1.42 to 1.68 m) diameter
Weight on tongue:	1410 pounds (635 kg) app.
Total weight:	4150 pounds (1868 kg) app.

SILATUBE P-6200 ASSEMBLY

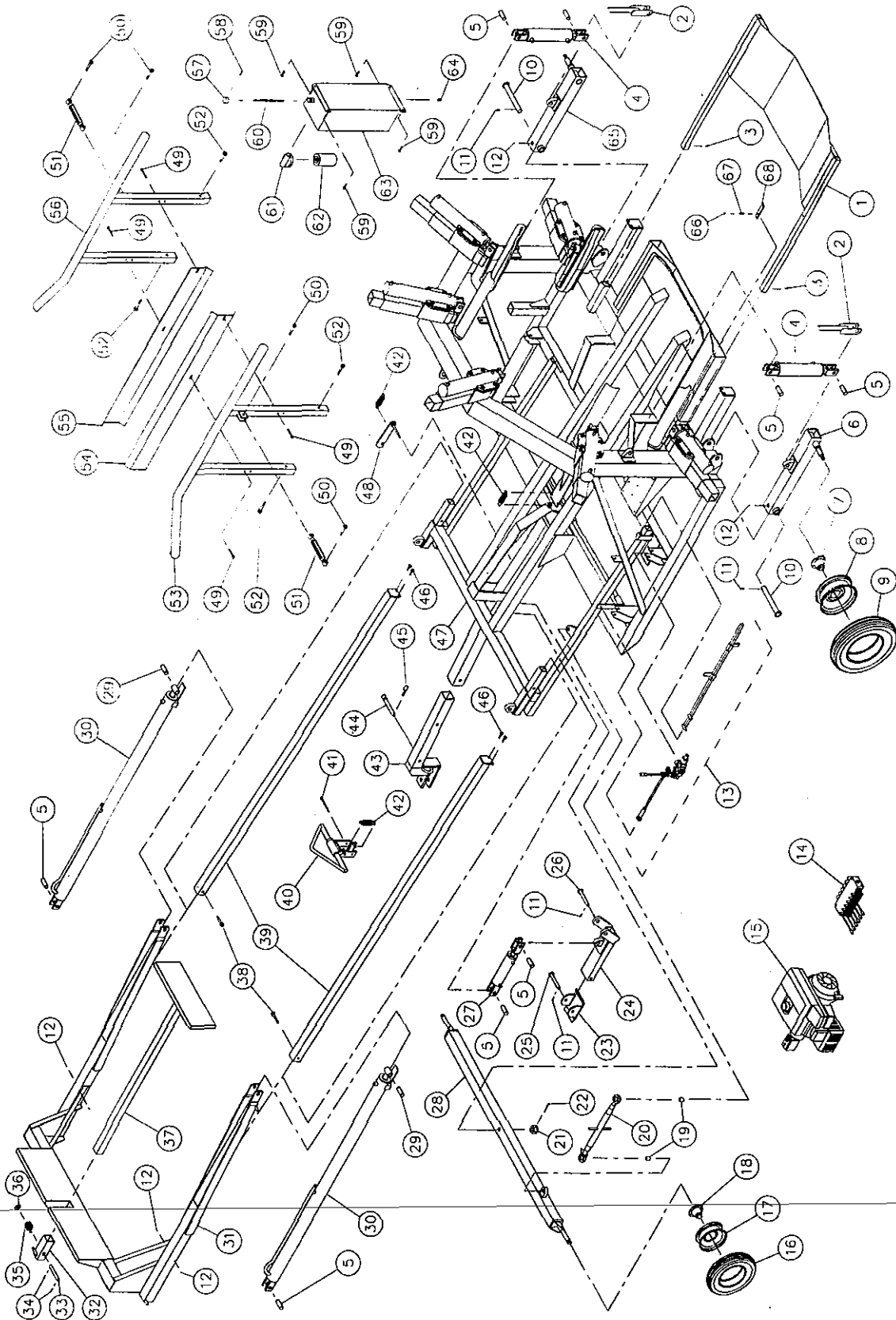

8

SILATUBE P-6200 ASSEMBLY (cont'd)

REF.	PART #	DESCRIPTION	QTY
1	32107	ProTube support plate	1
2	32108	Safety locking mechanism for rear wheels	2
3	Std.	Bolt ¼" NC x ¾" lg + nut & lock washer	2
4	25TR08	Cylinder 2.5" x 8" standard	2
5	D-60051	Pin 1" x 3" lg	8
6	32109	Left rear axle	1
7	32037	Hub H-511 (see details p. 38)	2
8	R-1555	Rim 15 x 5 x 5	2
9	PN-6.7015	Tire 6.7 x 15 - 6 ply + tube 6.70 x 15 TR-15	2
10	32034	Pin for rear axle (P-6200)	2
11	Std.	Cotter pin 5/32" x 1½" lg	4
12	Std.	Grease fitting ¼"-28 straight	6
13	32110	1 spool control valve (SD4 modified) (see details p.35)	1
14	32111	6 spool control valve (see details p. 33)	1
15	---	B&S 9 HP engine assembled with pump (see details p. 36)	1
16	PN-20.58	Tire 20.5 x 8 x 10 - 4 ply	2
17	R-1064	Rim 10 x 6 x 4	2
18	53015	Hub H-1000 (see details p. 37)	2
19	32112	Spacer ¾" i.d. x 1" o.d. x 1" lg	2
20	32113	Turnbuckles 20½" à 30½"	1
21	32114	Castle nut 1" - 8	1
22	Std.	Cotter pin 5/32" x 2"	1
23	32115	Base, hydraulic jack	1
24	32116	Body, hydraulic jack	1
25	32117	Pin for hydraulic jack base	1
26	32118	Pin for hydraulic jack body	1
27	25TR04	Cylinder 2.5 x 4" standard	1
28	32119	Front axle assembly (P-6200)	1
29	32019	Pin 1"	2
30	20G72	Cylinder 2" x 72" lg from serial number 1195 to 1304 (see details p. 32)	2
30	20I72	Cylinder 2" x 72" lg from serial number 1305 and over (see details p. 32)	2
31	32120	P-6200 bale pusher frame from serial number 1195 to 1304	1
31	32197	P-6200 bale pusher frame from serial number 1305 and over	1
32	32121	Pusher extension support	1
33	32122	Pin	1
34	Std.	Cotter pin 3/16" x 1¾" lg	2
35	32123	Pusher extension support spring	1
36	Std.	Washer 1"	1
37	32124	Pusher extension	1
38	Std.	Bolt 5/8" NC x 3½" lg + nut & lock washer	2
39	32022	Pusher guide	2
40	32125	Steering triangle from serial number 1195 to 1304	1
40	32198	Steering triangle from serial number 1305 and over	1
41	Std.	Bolt ½" x 5" lg + nylon locknut	1
42	32008	Tension spring 1¼" x 3½" lg	3
43	32126	Tongue from serial number 1195 to 1304	1
43	32199	Tongue from serial number 1305 and over	1
44	32024	Tongue pin	1
45	DA3070-56	Hitch pin clip	1
46	Std.	Bolt ½" NC x 1½" lg + nut & lock washer	4
47	32127	P-6200 main frame from serial number 1195 to 1304	1
47	32200	P-6200 main frame from serial number 1305 and over	1
48	32128	Locking mechanism for jack	1
49	Std.	Bolt 7/16" NC x 3" lg + nut + lock washer + flat washer	4
50	Std.	Bolt 5/8" NC x 2½" lg + nylon locknut	4
51	32014	Turnbuckle 10"	2

8

SILATUBE P-6200 ASSEMBLY (cont'd)

REF.	PART #	DESCRIPTION	QTY
52	Std.	Bolt 5/8" NC x 3 1/2" lg + nylon locknut.....	4
53	32025	Left bale guide (P-6200).....	1
54	32026	Left protector.....	1
55	32027	Right protector.....	1
56	32028	Right bale guide (P-6200).....	1
57	32029	Oil reservoir cap.....	1
58	Std.	Roll pin 5/32" x 1 3/4".....	1
59	Std.	Bolt 7/16" NC x 1" + nut & lock washer.....	4
60	32030	Dip stick.....	1
61	32031	Hydraulic oil filter adaptor FSP107-1E DNN.....	1
62	32007	Paper filter K-22001.....	1
63	32033	Oil reservoir.....	1
64	32032	Drain plug 1/2".....	1
65	32129	Right rear axle.....	1
66	Std.	Nylon locknut 1/4" NC.....	1
67	32130	Compression spring 13/32" x 1 1/2" lg.....	1
68	32131	Locking device for support plate.....	1

SILATUBE P-6300 ASSEMBLY

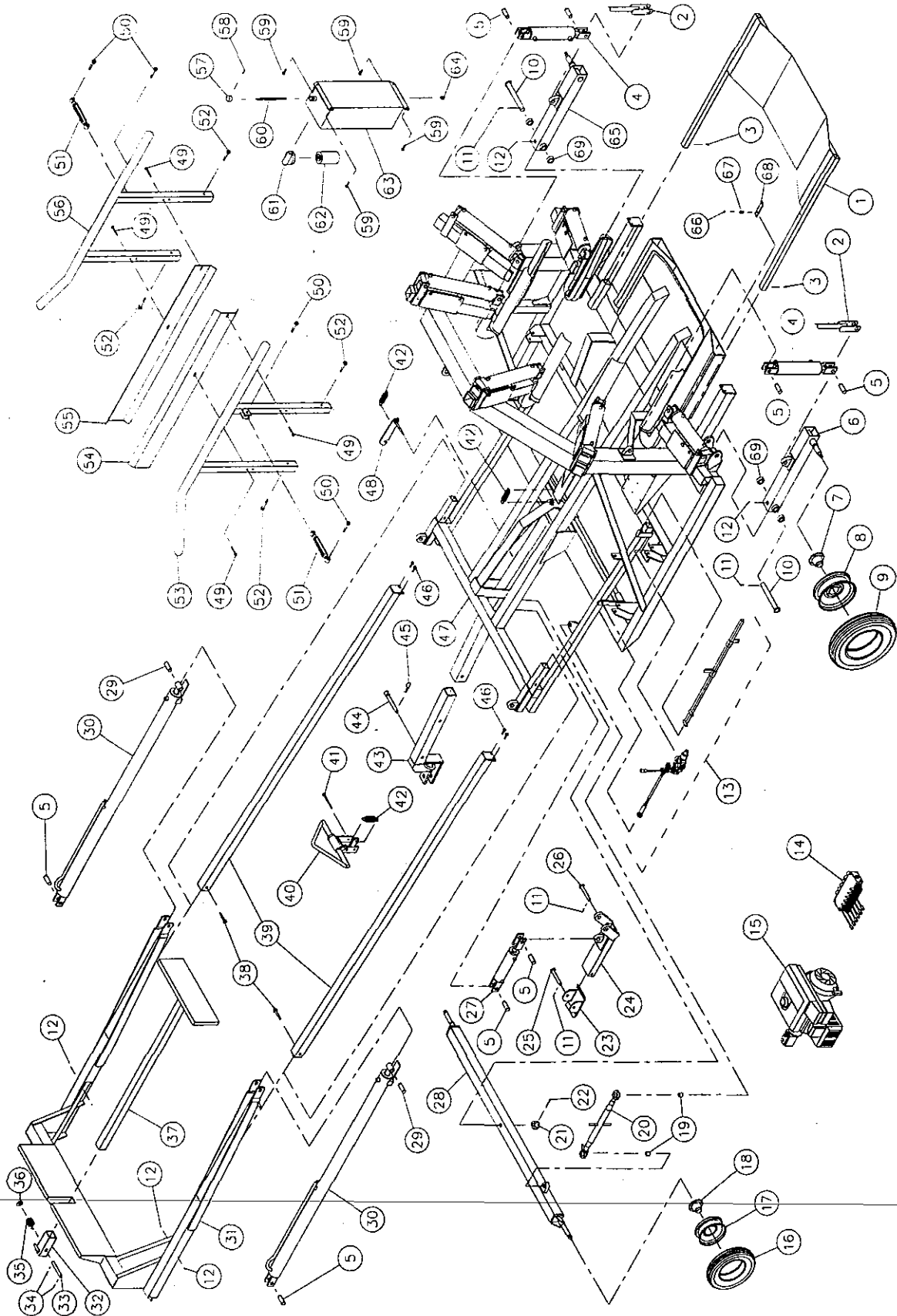

8

SILATUBE P-6300 ASSEMBLY (cont'd)

REF.	PART #	DESCRIPTION	QTY
1	32107	ProTube support plate	1
2	32108	Safety locking mechanism for rear wheels	2
3	Std.	Bolt ¼" NC x ¾" lg + nut & lock washer	2
4	25TR08	Cylinder 2.5" x 8" standard	2
5	D-60051	Pin 1" x 3" lg	8
6	32109	Left rear axle	1
7	32037	Hub H-511 (see details p. 38)	2
8	R-1555	Rim 15 x 5 x 5	2
9	PN-6.7015	Tire 6.7 x 15 - 6 ply + tube 6.70 x 15 TR-15	2
10	32093	Pin for rear axle (P-6300)	2
11	Std.	Cotter pin 5/32" x 1½" lg	4
12	Std.	Grease ¼"-28 fitting	6
13	32110	1 spool control valve SD4 modified (see details p. 35)	1
14	31111	6 spool control valve (see details p. 33)	1
15	---	B&S 9HP engine assembled with pump (see details p. 36)	1
16	PN-20.58	Tire 20.5 x 8 x 10 - 4 ply	2
17	R-1064	Rim 10 x 6 x 4	2
18	53015	Hub H-1000 (see details p. 37)	2
19	32112	Spacer ¾" i.d. x 1" o.d. x 1" lg	2
20	32113	Turnbuckles 20½" to 30½"	1
21	32114	Castle nut 1" - 8	1
22	Std.	Cotter pin 5/32" x 2"	1
23	32115	Base, hydraulic jack	1
24	32116	Body, hydraulic jack	1
25	32117	Pin for hydraulic jack base	1
26	32118	Pin for hydraulic jack body	1
27	25TR04	Cylinder 2.5 x 4" standard	1
28	32162	Front axle assembly (P-6300)	1
29	32019	Pin 1"	2
30	20G72	Cylinder 2" x 72" lg from serial number 1195 to 1304 (see details p. 32)	2
30	20I72	Cylinder 2" x 72" lg from serial number 1305 and over (see details p. 32)	2
31	32163	P-6300 bale pusher frame from serial number 1195 to 1304	1
31	32201	P-6300 bale pusher frame from serial number 1305 and over	1
32	32121	Pusher extension support	1
33	32122	Pin	1
34	Std.	Cotter pin 3/16" x 1¼" lg	2
35	32123	Pusher extension support spring	1
36	Std.	Washer 1"	1
37	32124	Pusher extension	1
38	Std.	Bolt 5/8" NC x 3½" lg + nut & lock washer	2
39	32022	Pusher guide	2
40	32125	Steering triangle from serial number 1195 to 1304	1
40	32198	Steering triangle from serial number 1305 and over	1
41	Std.	Bolt ½" x 5" lg + nylon locknut	1
42	32008	Tension spring 1¼" x 3½" lg	3
43	32126	Tongue from serial number 1195 to 1304	1
43	32199	Tongue from serial number 1305 and over	1
44	32024	Tongue spring	1
45	DA3070-56	Hitch pin clip 5/32"	1
46	Std.	Bolt ½" NC x 1½" lg + nut & lock washer	4
47	32164	P-6300 main frame from serial number 1195 to 1304	1
47	32202	P-6300 main frame from serial number 1305 and over	1
48	32128	Locking mechanism for jack	1
49	Std.	Bolt 7/16" NC x 3" lg + nut + lock washer + flat washer	4
50	Std.	Bolt 5/8" NC x 2½" lg + nylon locknut	4
51	32014	Turnbuckle 10"	2

8

SILATUBE P-6300 ASSEMBLY (cont'd)

REF.	PART #	DESCRIPTION	QTY
52	Std.	Bolt 5/8" NC x 3 1/2" lg + nylon locknut	4
53	32165	Left bale guide (P-6300)	1
54	32026	Left protector	1
55	32027	Right protector	1
56	32166	Right bale guide (P-6300)	1
57	32029	Oil reservoir cap	1
58	Std.	Roll pin 5/32" x 1 3/4"	1
59	Std.	Bolt 7/16" NC x 1" + nut & lock washer	4
60	32030	Dip stick	1
61	32031	Hydraulic oil filter adaptor FSP107-1E DNN	1
62	32007	Paper filter K-22001	1
63	32033	Oil reservoir	1
64	32032	Drain plug 1/2"	1
65	32129	Right rear axle	1
66	Std.	Nylon locknut 1/4" NC	1
67	32130	Compression spring 13/32" x 1 1/2" lg	1
68	32131	Locking device for support plate	1
69	32094	Spacer 1 1/4" x 1/2" lg	1

DETAIL OF ARCH MODEL P-6200

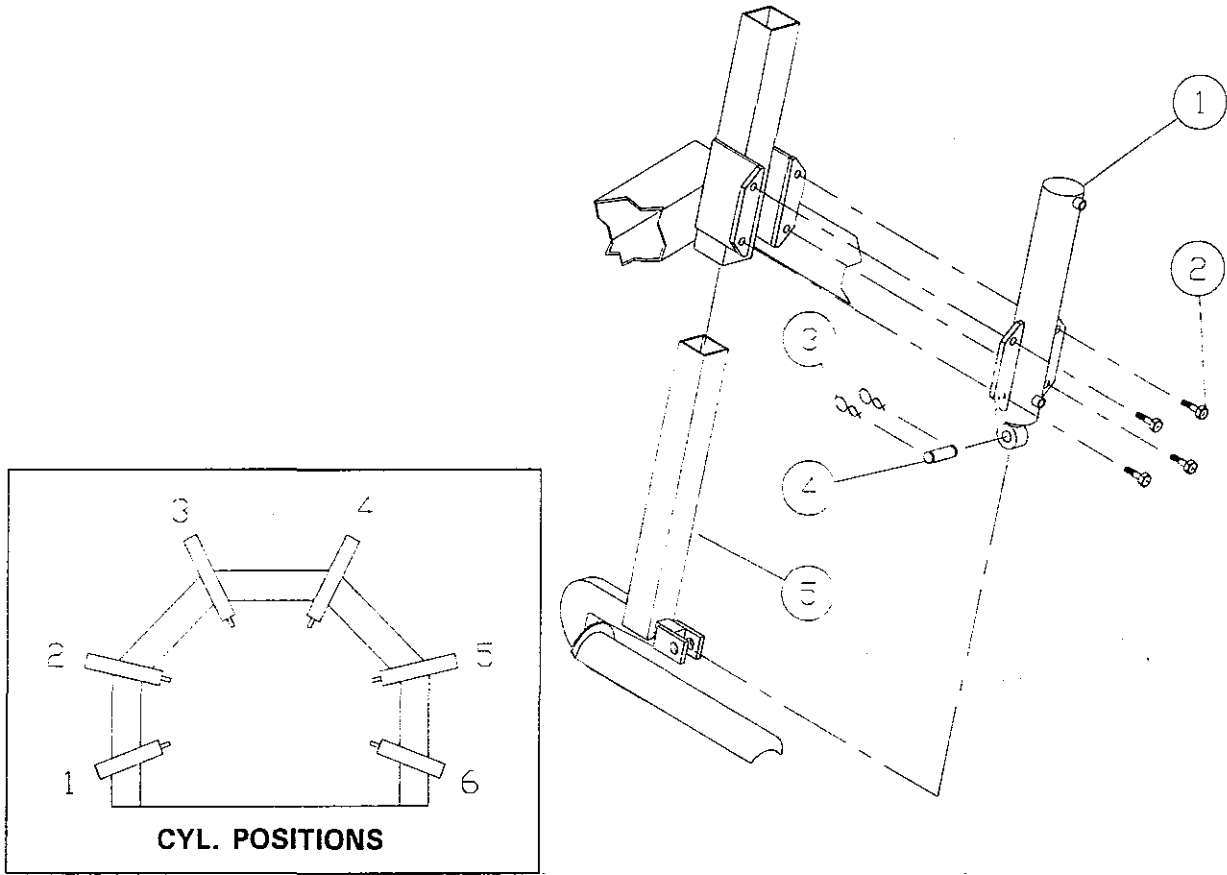

REF.	PART #	DESCRIPTION	QTY CYL. POSITION #					
			1	2	3	4	5	6
1	30Z10	Cylinder	1	-	-	-	-	1
1	30Z15	Cylinder	-	1	-	-	1	-
1	30Z17	Cylinder	-	-	1	1	-	-
2	Std.	Bolt 5/8" NC x 2" lg + nut & lock washer	4	4	4	4	4	4
3	Std.	Hair pin 1/8"	2	2	2	2	2	2
4	Std.	Pin 1"	1	1	1	1	1	1
5	32038	Stretchers arm	1	-	-	-	-	1
5	32039	Stretchers arm	-	1	-	-	1	-
5	32040	Stretchers arm	-	-	1	1	-	-

8

DETAIL OF ARCH MODEL P-6300

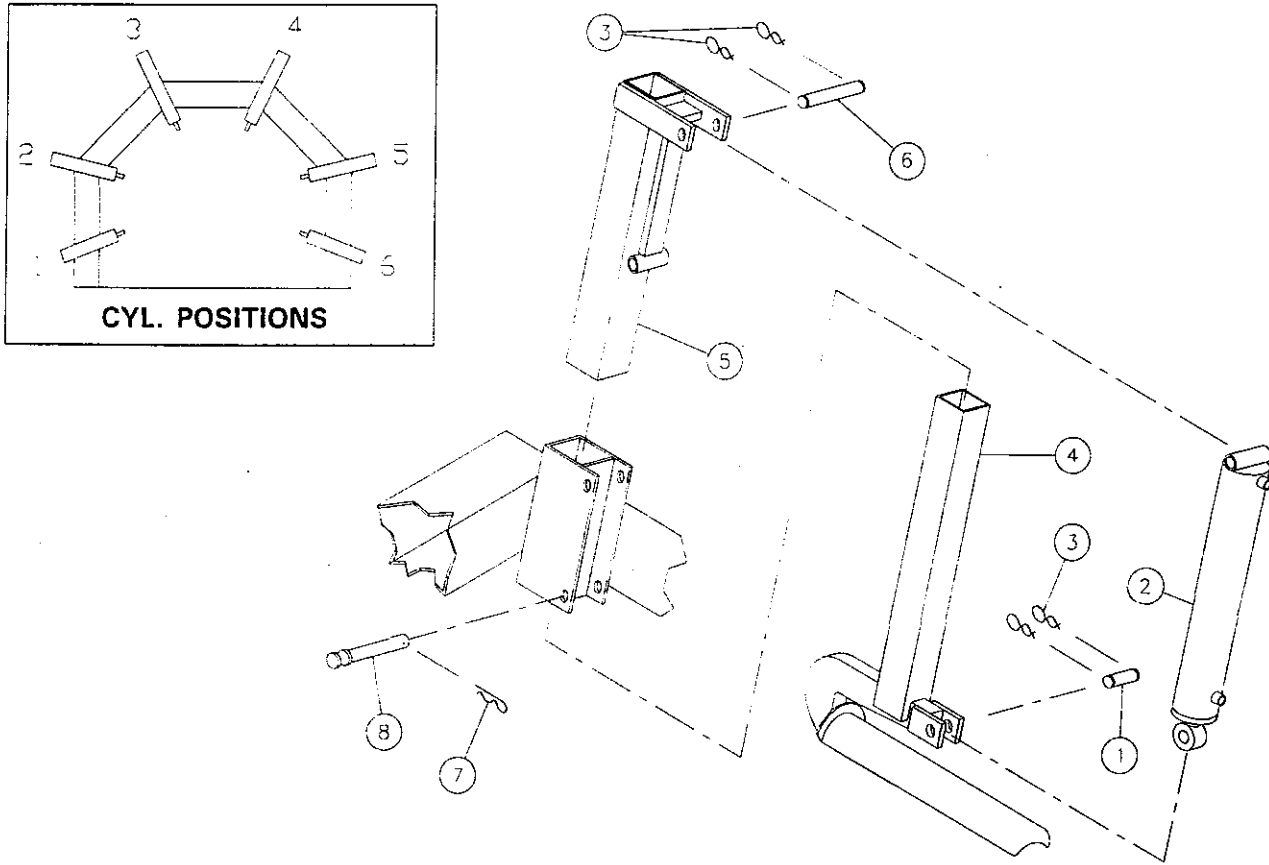

REF.	PART #	DESCRIPTION	QTY CYL POSITION #					
			1	2	3	4	5	6
1	Std.	Pin 1" x 3" lg	1	1	1	1	1	1
2	30H10	Cylinder	1	-	-	-	-	1
2	30H15	Cylinder	-	1	-	-	1	-
2	30H17	Cylinder	-	-	1	1	-	-
3	Std.	Hair pin 1/8"	4	4	4	4	4	4
4	32152	Stretcher arm	1	-	-	-	-	-
4	32153	Stretcher arm	-	1	-	-	-	-
4	32154	Stretcher arm	-	-	1	-	-	-
4	32155	Stretcher arm	-	-	-	1	1	-
4	32156	Stretcher arm	-	-	-	-	-	1
5	32157	Stretcher arm guide	1	-	-	-	-	1
5	32158	Stretcher arm guide	-	1	-	-	1	-
5	32159	Stretcher arm guide	-	-	1	1	-	-
6	32160	Pin 1" x 5" lg	1	1	1	1	1	1
7	Std.	Hitch pin clip 5/32"	1	1	1	1	1	1
8	32161	Pin 1" x 5 1/4" lg	1	1	1	1	1	1

8

AUTOMATIC SYSTEM DETAIL

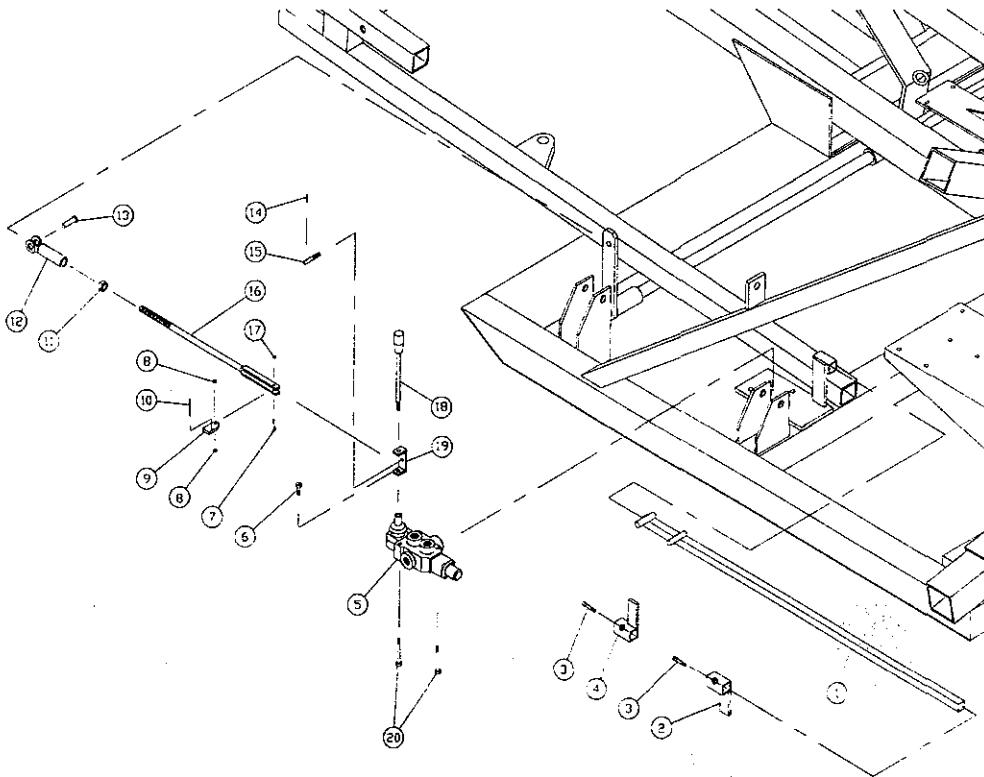

REF.	PART #	DESCRIPTION	QTY
1	32139	Rod (P-6200)	1 -
1	32140	Rod (P-6300)	- 1
2	32141	Rear stopper	1 1
3	Std.	Square head set screw 5/16" NC x 3/4" lg	2 2
4	32142	Front stopper	1 1
5	32110	1 spool control valve (SD4 modified) (see details p. 35)	1 1
6	Std.	Bolt M8 x 1.25 x 16mm lg + lock washer	1 1
7	Std.	Flat head screw 10-24 UNC x 1" lg + nylon locknut	1 1
8	32144	Flat washer 3/16 (brass)	2 2
9	32145	Lever	1 1
10	Std.	Roll pin 5/32" X 1 3/4" lg	1 1
11	Std.	Nut 1/2" NF	1 1
12	51435	Clevis 1/2" NF	1 1
13	51436	Pin 1/2" ø x 1 3/4" lg + cotter pin 1/8" x 3/4" lg	1 1
14	Std.	Roll pin 5/32" x 3/4" lg	1 1
15	32146	Valve actuator pin + 2 nut 5/16" NC + lock washer	1 1
16	32147	Rod (P-6200)	1 -
16	32148	Rod (P-6300)	- 1
17	32149	Lock washer 3/16"	1 1
18	32150	Spool handle + 2 nut M8 x 1.25	1 1
19	32151	Spool handle support	1 1
20	Std.	Bolt 5/16"NC x 2 1/2" lg + nut & lock washer	2 2

8

ARCH CYLINDER P-6200

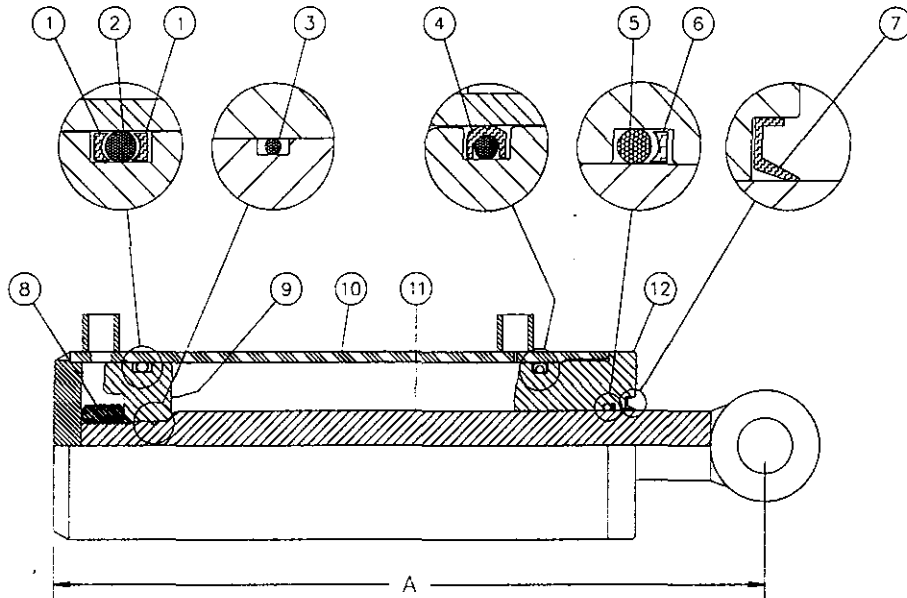

MODEL	LENGTH A
30Z10	16"
30Z15	21"
30Z17	23"

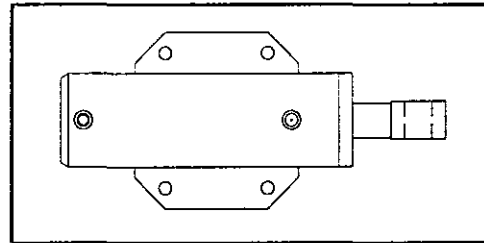

REF.	PART #	DESCRIPTION	QTY CYLINDER #		
			30Z10	30Z15	30Z17
1	BU-334	Back-up ring 3/16" x 2 5/8" x 3"	3	2	2
2	OR-334	O-ring 3/16" x 2 5/8" x 3"	2	2	2
3	OR-018	O-ring 1/16" x 3/4" x 7/8"	1	1	1
4	PSP-334	O-ring "heavy duty" 3/16" x 2 5/8" x 3"	1	1	1
5	OR-218	O-ring 1/8" x 1 1/4" x 1 1/2"	1	1	1
6	BU-218	Back-up ring 1/8" x 1 1/4" x 1 1/2"	1	1	1
7	CR12330	Wiper 1/8" x 1 1/4" x 1 1/2"	1	1	1
8	Std.	Nut 7/8" NF	1	1	1
9	D-6000	Piston 3" dia.	1	1	1
10	D-6096	Cylinder body 3" for 30Z10	1	-	-
10	D-6097	Cylinder body 3" for 30Z15	-	1	-
10	D-6098	Cylinder body 3" for 30Z17	-	-	1
11	D-6099	Piston rod 1 1/4" for 30Z10 and 30H10	1	-	-
11	D-6100	Piston rod 1 1/4" for 30Z15 and 30H15	-	1	-
11	D-6101	Piston rod 1 1/4" for 30Z17 and 30H17	-	-	1
12	D-6093	Head 3" dia.	1	1	1

8

ARCH CYLINDER P-6300

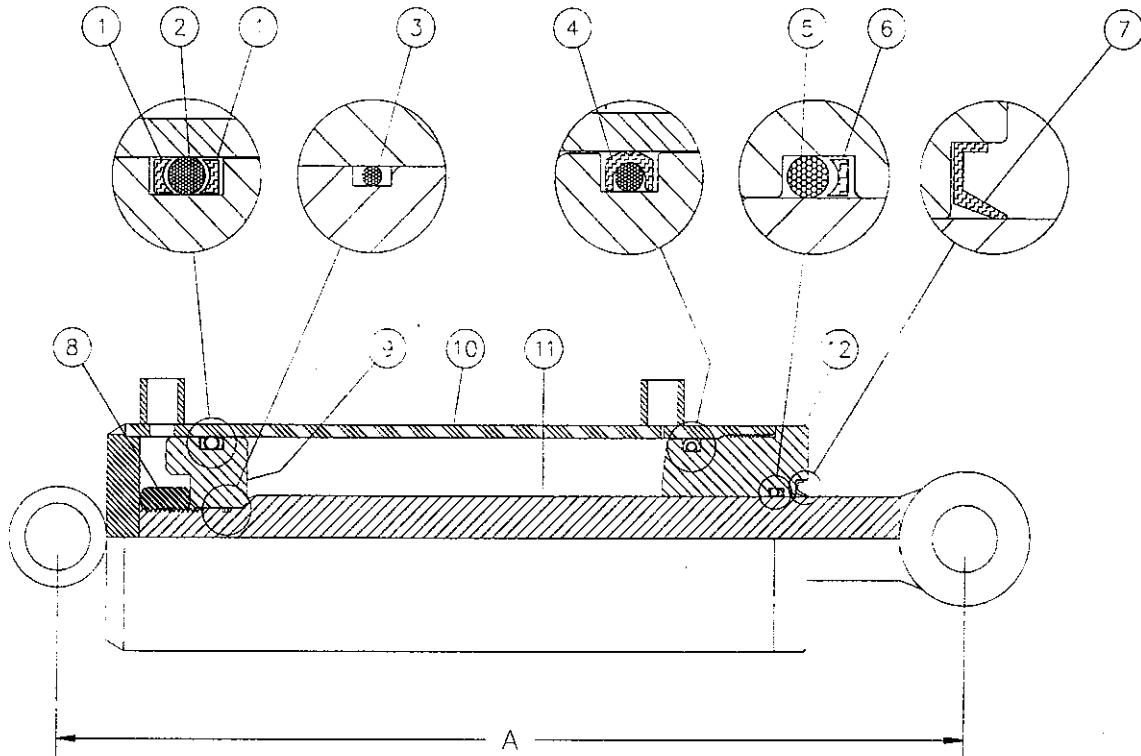

MODEL	LENGTH A
30H10	16 3/4"
30H15	21 3/4"
30H17	23 3/4"

REF.	PART #	DESCRIPTION	QTY CYLINDER #		
			30H10	30H15	30H17
1	BU-334	Back-up ring 3/16" x 2 5/8" x 3"	3	2	2
2	OR-334	O-ring 3/16" x 2 5/8" x 3"	2	2	2
3	OR-018	O-ring 1/16" x 3/4" x 7/8"	1	1	1
4	PSP-334	O-ring "heavy duty" 3/16" x 2 5/8" x 3"	1	1	1
5	OR-218	O-ring 1/8" x 1 1/4" x 1 1/2"	1	1	1
6	BU-218	Back-up ring 1/8" x 1 1/4" x 1 1/2"	1	1	1
7	CR12330	Wiper 1/8" x 1 1/4" x 1 1/2"	1	1	1
8	Std.	Nut 7/8" NF	1	1	1
9	D-6000	Piston 3" dia.	1	1	1
10	D-6168	Cylinder body 3" for 30H10.....	1	-	-
10	D-6169	Cylinder body 3" for 30H15.....	-	1	-
10	D-6170	Cylinder body 3" for 30H17.....	-	-	1
11	D-6099	Piston rod 1 1/4" for 30Z10 and 30H10.....	1	-	-
11	D-6100	Piston rod 1 1/4" for 30Z15 and 30H15.....	-	1	-
11	D-6101	Piston rod 1 1/4" for 30Z17 and 30H17.....	-	-	1
12	D-6093	Head 3" dia.	1	1	1

8

PUSHER CYLINDER # 20G72 & # 20I72

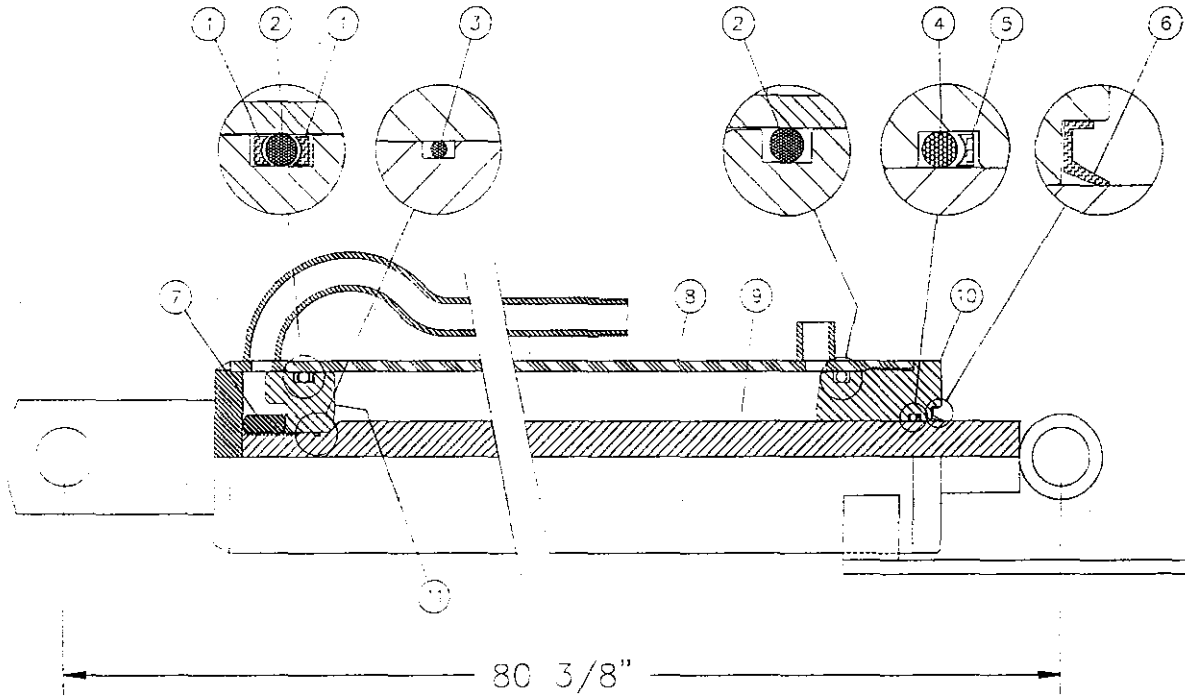

REF.	PART #	DESCRIPTION	QTY	
			20G72	20I72
1	BU-326	Back-up ring 3/16" x 1 5/8" x 2"	2	2
2	OR-326	O-ring 3/16" x 1 5/8" x 2"	2	2
3	OR-016	O-ring 1/16" x 5/8" x 3/4"	1	1
4	OR-218	O-ring 1/8" x 1 1/4" x 1 1/2"	1	1
5	BU-218	Back-up ring 1/8" x 1 1/4" x 1 1/2"	1	1
6	CR12330	Wiper 1/8" x 1 1/4" x 1 1/2"	1	1
7	Std.	Nut 3/4" NF	1	1
8	D-6118	20G72 cylinder body 2" ø from serial number 1195 to 12304	1	-
8	D-6179	20I72 cylinder body 2" ø from serial number 1305 and over	-	1
9	D-6172	Piston rod 1 1/4" ø for 20G72 & 20I72	1	1
10	D-6032	Head 2" ø	1	1
11	D-6020	Piston 2" ø	1	1

8

6 SPOOL CONTROL VALVE # 32111

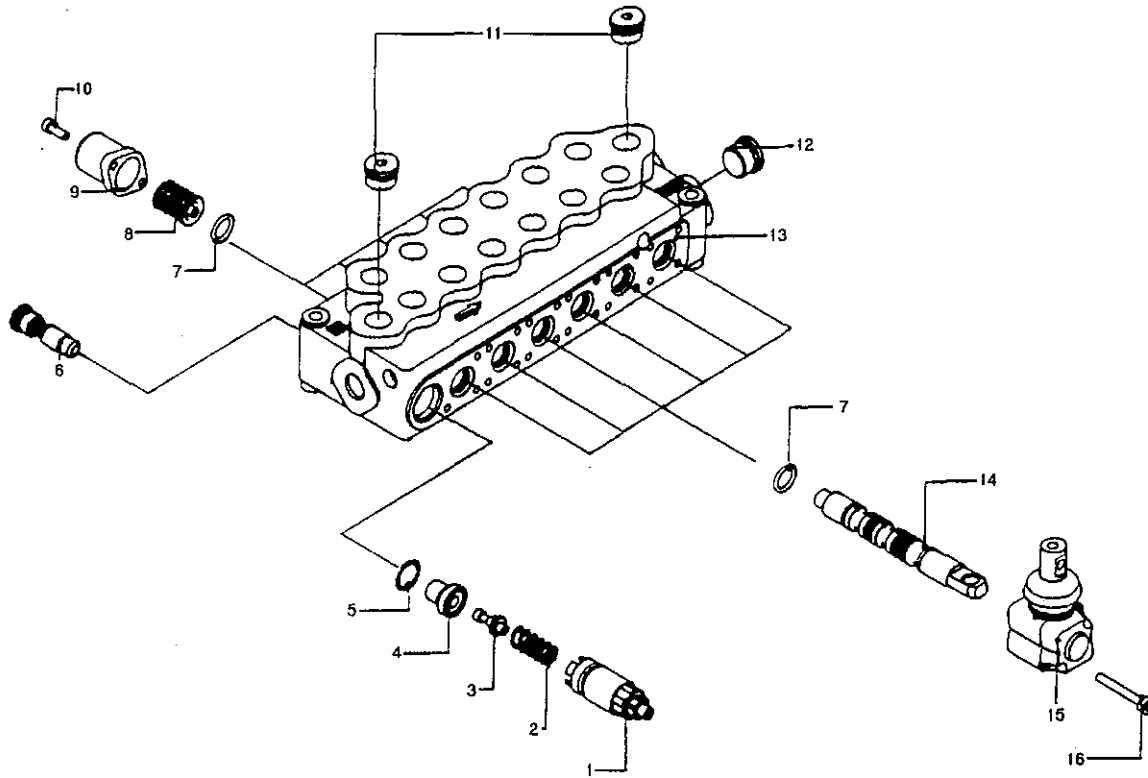

REF.	PART #	CODE #	DESCRIPTION	QTY
1	32167	XKIT105211	Relief valve	1
	32071	3MOL315330	Spring	1
3	32072	3OTT213260	Spring seat pusher	1
	32073	3ANE220210	Ring	1
	32074	3ANE120010	Seal	1
	32076	XKIT005000	Kit VR5	1
	32077	4GUA115926	O-ring	12
	32078	XV08105000	Spring	6
	32079	3CAP210370	Endcap	6
10	32080	4VIT605014	Screw M5 x14	12
11	32081	3XTAP822150	Plug SAE8	2
	32082	3XTAP623170	Plug	1
13	32168	3CO1357000	Valve housing	1
	32085	3CU1210130	Valve spool	6
15	32086	3XLEV105000	Lever	6
16	32087	4VIT605035	Screw M5 x 35	12

8

1 SPOOL CONTROL VALVE # 32138 (SD4 standard)

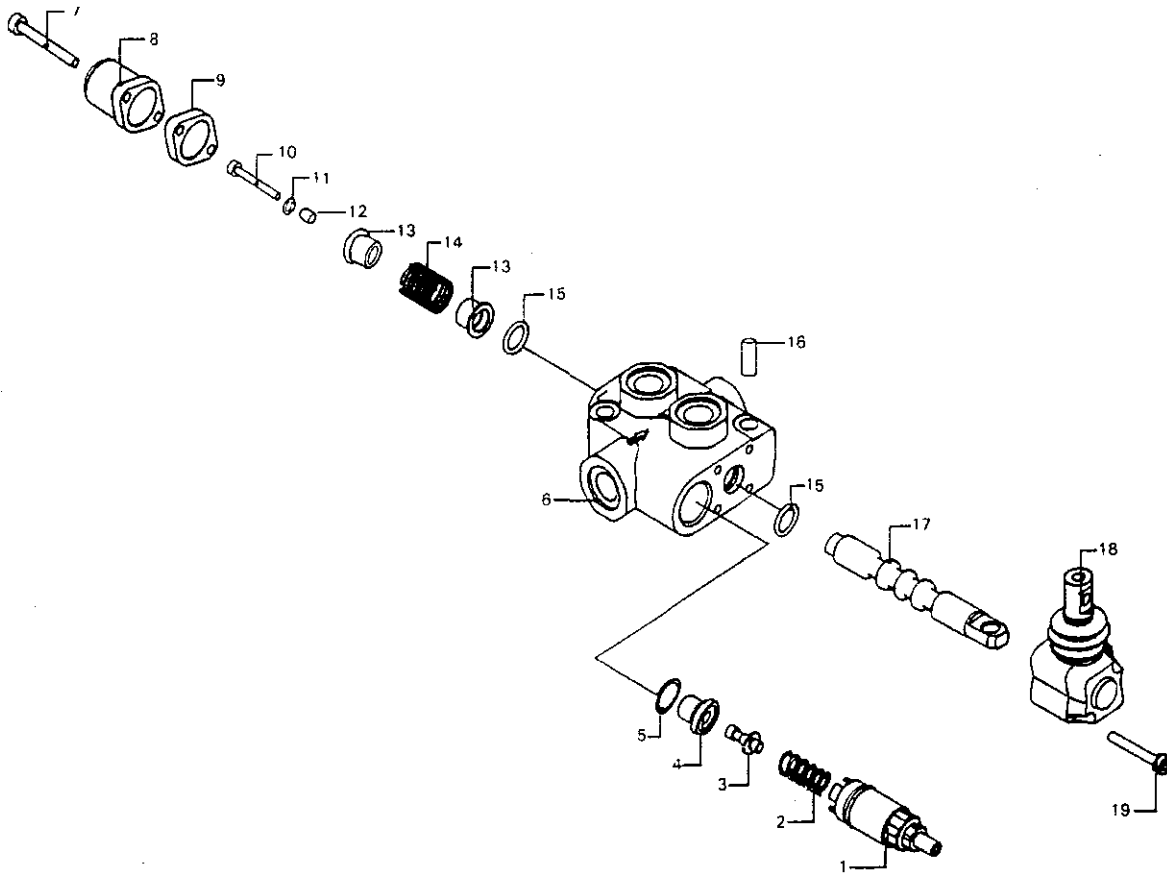

REF.	PART #	CODE #	DESCRIPTION	QTY
1	32167	XKIT105211	Relief valve	1
2	32169	3MOL314341	Spring	1
3	32072	3OTT213260	Spring seat pusher	1
4	32073	3ANE220210	Ring	1
5	32074	3ANE120010	Seal	1
6	32170	3CO1103000	Valve housing	1
7	32171	4VIT605018	Bolt M5 x 18	2
8	32079	3CAP210370	Endcap	1
9	32172	3DIS12104N	Spacer	1
10	32173	4VIT508035	Bolt M8 x 35	1
11	32174	3ANE112010	Ring	1
12	32175	3ANE109091	Ring	1
13	32176	3BOC119120	Spring retainer	2
14	32177	3MOL419430	Spring	1
15	32178	4GUA115926	O-ring (121)	1
16	32179	4SPI510022	Roll pin	1
17	32180	3CU1110100	Valve spool	1
18	32086	3XLEV105000	Lever	1

8

1 SPOOL CONTROL VALVE # 32110 (SD4 modified)

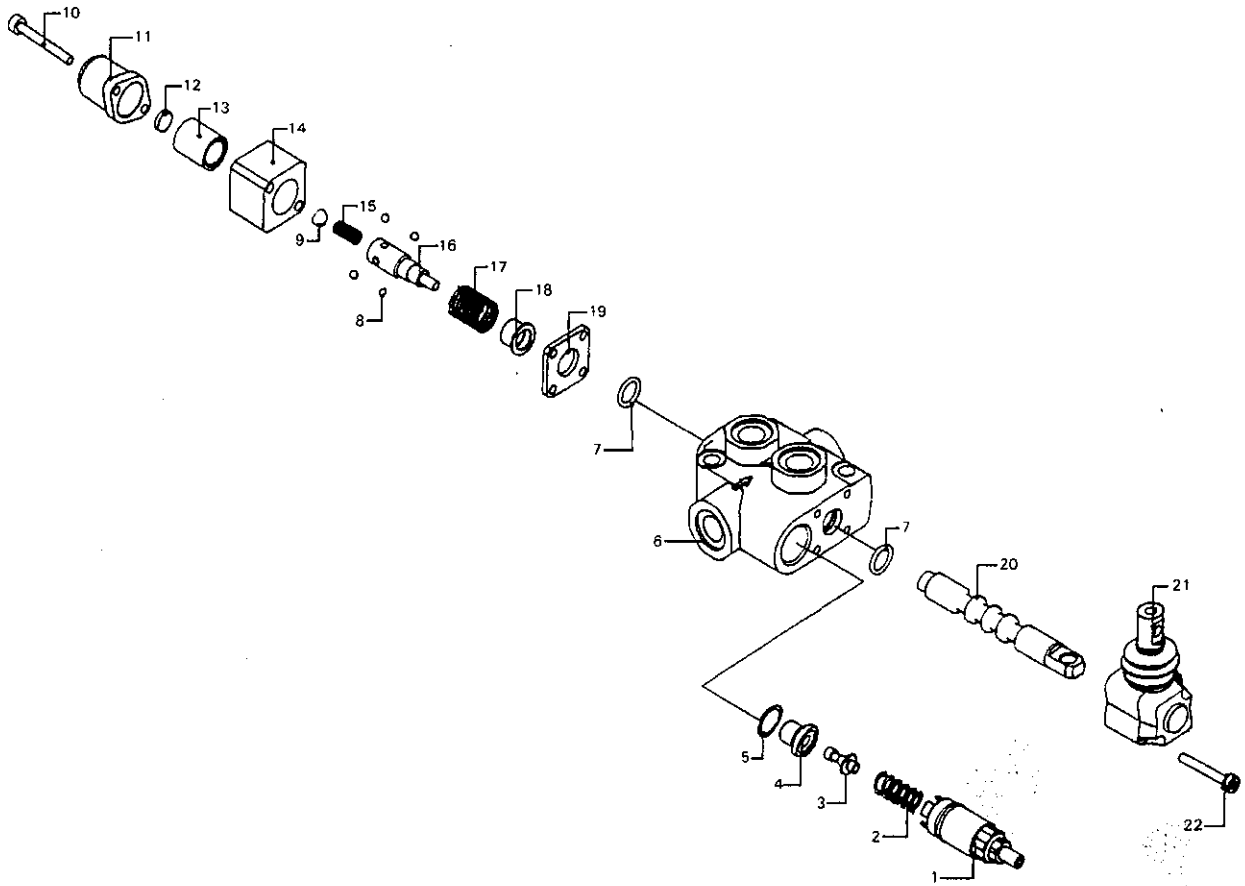

REF.	PART #	CODE #	DESCRIPTION	QTY
1	32167	XKIT105211	Relief valve	1
2	32071	3MOL315330	Spring	1
3	32072	3OTT213260	Spring seat pusher	1
4	32073	3ANE220210	Ring	1
5	32074	3ANE120010	Seal	1
6	32181	3CO1116000	Valve housing	1
7	32077	4GUA115926	O-ring	2
8	32182	4SFE204762	Ball 4.762	4
9	32183	4SFE209525	Ball 9.525	1
10	32184	4VIT605050	Bolt M5 x 50	2
11	32079	3CAP210370	Endcap	1
12	32185	3SPE112030	Spacer	1
13	32186	3BUS221271	Bushing	1
14	32187	3CAP220331	Cap	1
15	32188	3MOL208280	Spring	1
16	32189	3PER115571	Pin	1
17	32190	3MOL419500	Spring	1
18	32191	3BOC119130	Bushing	1
19	32192	3DIS121035	Nylon spacer	1
20	32193	3CU1110120	Spool	1
21	32086	3XLEV105000	Lever	1
22	32087	4VIT605035	Screw M5 x 35	2

8

ENGINE ASSEMBLY WITH PUMP

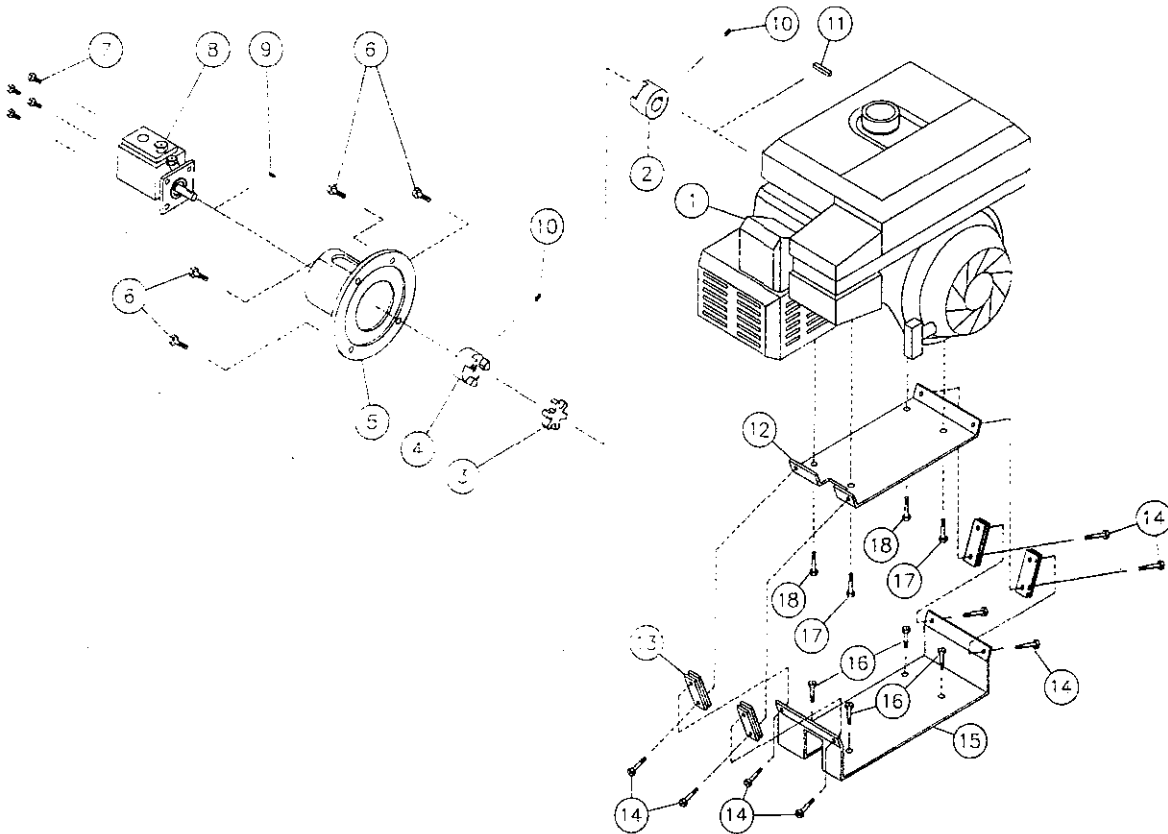

8

REF.	PART #	DESCRIPTION	QTY SILATUBES' SERIAL #	
			1226 & -	1227 & +
1	32011	Engine B&S 9HP	1 -
1	32132	Engine B&S 9HP	- 1
2	32006	Flexible coupling 1" ø	1 -
2	32133	Flexible coupling 1" ø	- 1
3	32005	Flexible coupling	1 -
3	32134	Flexible coupling	- 1
4	32004	Flexible coupling ½" ø	1 -
4	32135	Flexible coupling ½" ø	- 1
5	32088	Mounting flange	1 -
5	32136	Mounting flange	- 1
6	Std.	Bolt 3/8" NC x 1" lg + lock washer	4 4
7	Std.	Bolt 5/16" NC x 3/4" lg + lock washer	4 4
8	32002	Pump	1 1
9	Std	Woodruff key 1/8"	1 1
10	Std.	Socket set screw 5/16" NC x 1/2"	2 2
11	Std.	Square key 1/4" x 1 1/2" lg	1 1
12	32194	Upper motor mounting plate	- 1
13	32195	Anti-vibration supports	- 8
14	Std.	Bolt 5/16" NC x 1" lg + nylon locknut & flat washer	- 8
15	32196	Lower motor mounting plate	- 1
16	Std.	Bolt 3/8" NC x 1" lg + nut & lock washer	- 4
17	Std.	Bolt 3/8" NC x 1 ½" lg + nut & lock washer	- 2
18	Std.	Bolt 3/8" NC x 1 ½" lg + nut + lock washer & flat washer	- 2

FRONT HUB H1000

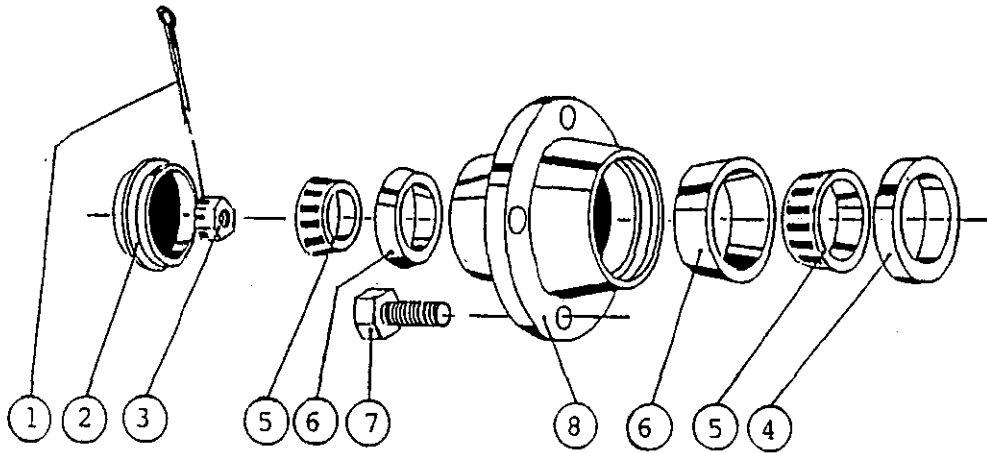

REF.	PART #	DESCRIPTION	QTY
1	Std.	Cotter pin 3/16" x 1 1/2"	1
2	53019	Dust cap 1.973 ø.	1
3	53020	Castle nut 1" NF	1
4	53021	Oil seal no. CR523696	1
5	53022	Roller bearing Timken: cone no. L44643	2
6	53023	Roller bearing Timken: cup no. L44610	2
7	53024	Rim screw 1/2"	4
8	53025	Hub only H1000	1

8

REAR HUB H511

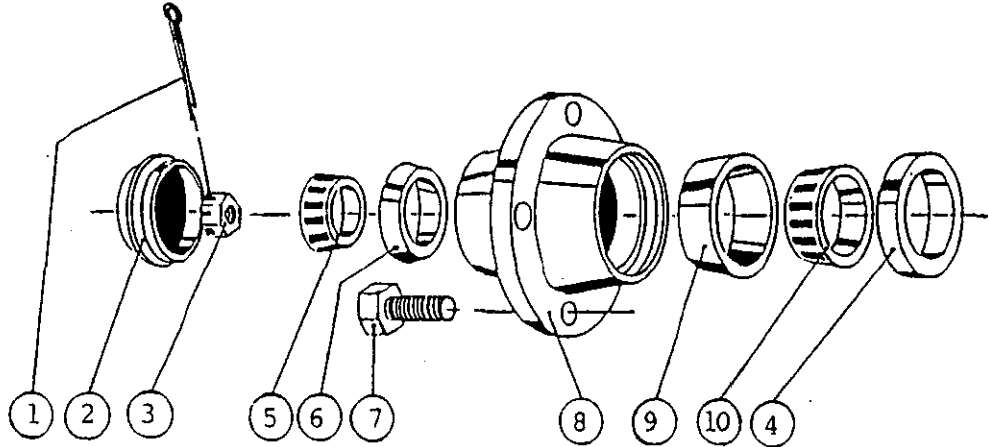

REF.	PART #	DESCRIPTION	QTY
1	Std.	Cotter pin 3/16" x 1 1/2"	1
2	32100	Dust cap (DC12)	1
3	32101	Castle nut 3/4" NF	1
4	32102	Oil seal SE11	1
5	32103	Roller bearing Timken: cone no. LM11949	1
6	32104	Roller bearing Timken: cup no. LM11910	1
7	32105	Rim screw WB10	5
8	32106	Hub only H511	1
9	51531	Roller bearing Timken: cup no. LM67010	1
10	51530	Roller bearing Timken: cone no. LM67048	1

8

HYDRAULIC SYSTEM

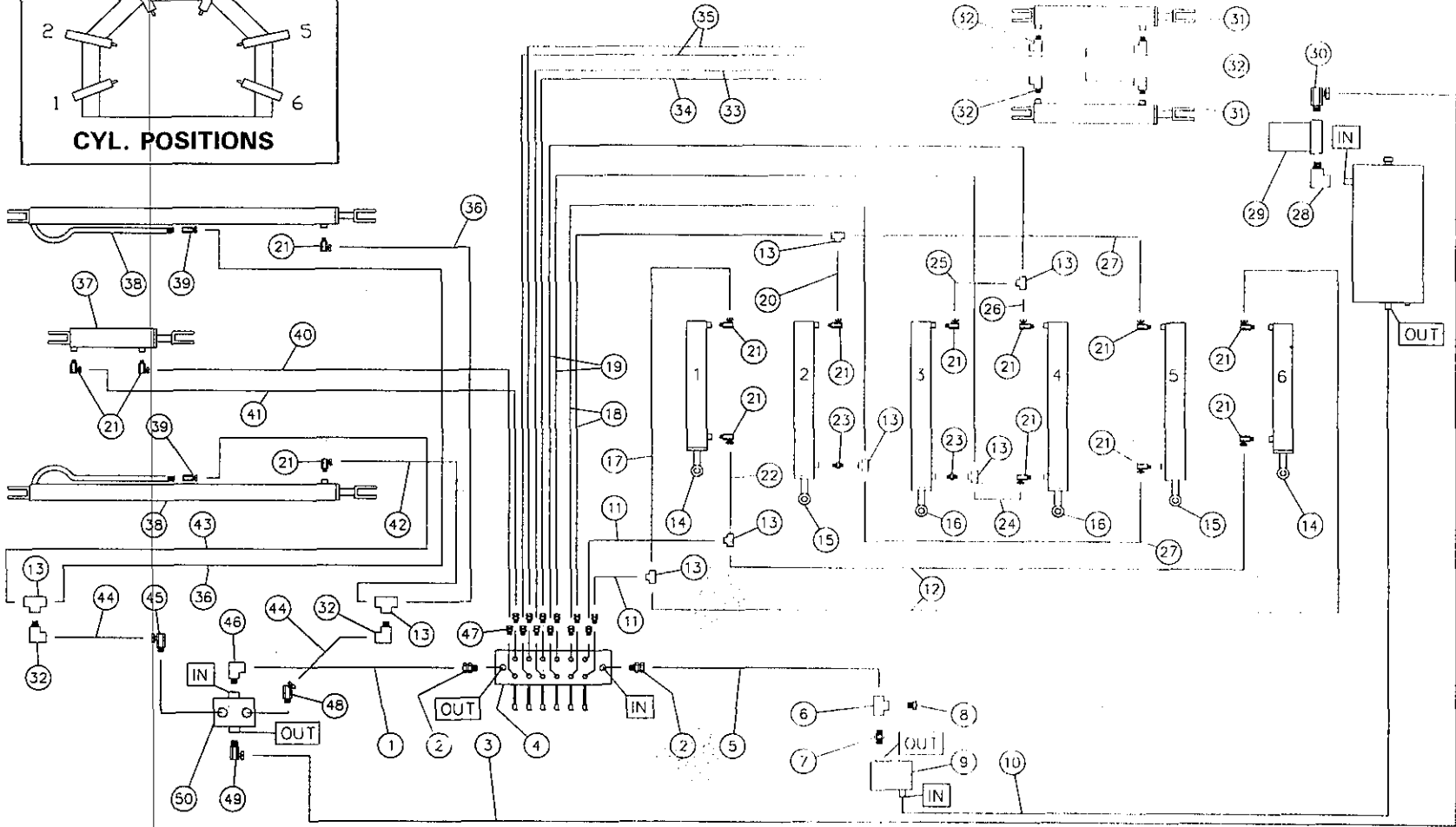
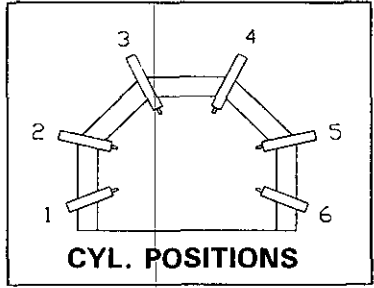

HYDRAULIC SYSTEM (cont'd)

REF.	PART #	DESCRIPTION	QTY	
			P-6200	P-6300
1	D-18088	Hose ½" x 79" lg + 2 fittings 8U108	1	1
2	Std.	Fitting 9315 8 x 8	2	2
3	D-18089	Hose ½" x 140" lg + 2 fittings 8U108	1	1
4	32111	6 spool control valve (see details page 33)	1	1
5	D-8668	Hose ½" x 38" lg + 2 fittings 8U108	1	1
6	Std.	"T" ½" C3709 x 8	3	3
7	Std.	Straight female pipe to male pipe ½" C3069 x 8	3	3
8	Std.	Plug ½" C3159 x 8	1	1
9	32002	Two stages 4/11 hydraulic pump	1	1
10	D-8727	Low pressure hose 1" x 116½" lg	1	-
10	D-18090	Low pressure hose 1" x 123" lg	-	1
11	D-18091	Hose 3/8" x 37" lg + 2 fittings 6U106	2	-
11	D-18092	Hose 3/8" x 45" lg + 2 fittings 6U106	-	2
12	D-8678	Hose 3/8" x 117" lg + 2 fittings 6U106	2	-
12	D-18093	Hose 3/8" x 125" lg + 2 fittings 6U106	-	2
13	Std.	"T" 3/8" C3709 x 6	8	8
14	30Z10	Cylinder 3" x 10" stroke (see details page 30)	2	-
14	30H10	Cylinder 3" x 10" stroke (see details page 31)	-	2
15	30Z15	Cylinder 3" x 15" stroke (see details page 30)	2	-
15	30H15	Cylinder 3" x 15" stroke (see details page 31)	-	2
16	30Z17	Cylinder 3" x 17" stroke (see details page 30)	2	-
16	30H17	Cylinder 3" x 17" stroke (see details page 31)	-	2
17	D-8723	Hose 3/8" x 19 ½" lg + 2 fittings 6U106	1	-
17	D-18094	Hose 3/8" x 26" lg + 2 fittings 6U106	-	1
18	D-8675	Hose 3/8" x 31" lg + 2 fittings 6U106	2	-
18	D-18095	Hose 3/8" x 42" lg + 2 fittings 6U106	-	2
19	D-8676	Hose 3/8" x 58" lg + 2 fittings 6U106	2	-
19	D-8760	Hose 3/8" x 64" lg + 2 fittings 6U106	-	2
20	D-18096	Hose 3/8" x 11" lg + 2 fittings 6U106	1	1
21	Std.	Fitting 9405 6x6	14	14
22	D-8724	Hose 3/8" x 22" lg + 2 fittings 6U106	1	-
22	D-18097	Hose 3/8" x 29" lg + 2 fittings 6U106	-	1
23	Std.	Close nipple 3/8" C3069 x 6	2	2
24	D-8673	Hose 3/8" x 43 ½" lg + 2 fittings 6U106	1	-
24	D-18098	Hose 3/8" x 49" lg + 2 fittings 6U106	-	1
25	D-18099	Hose 3/8" x 12 ¾" lg + 2 fittings 6U106	1	1
26	D-8677	Hose 3/8" x 50 ½" lg + 2 fittings 6U106	1	-
26	D-18100	Hose 3/8" x 52" lg + 2 fittings 6U106	-	1
27	D-8674	Hose 3/8" x 123" lg + 2 fittings 6U106	2	-
27	D-18101	Hose 3/8" x 144" lg + 2 fittings 6U106	-	2
28	Std.	Street elbow 3/4" 90° C3409 x 6	1	1
29		Paper filter 32007 + hydraulic oil filter adaptor 32031	1	1
30	Std.	Fitting 9205 8x12	1	1
31	25TR08	Cylinder 2 ½" x 8"	2	2
32	Std.	Street elbow 3/8" 90° C3409 x 6	6	6
33	D-8665	Hose 3/8" x 38" lg + 2 fittings 6U106	1	-
33	D-18095	Hose 3/8" x 42" lg + 2 fittings 6U106	-	1
34	D-18102	Hose 3/8" x 35 ½" lg + 2 fittings 6U106	1	-
34	D-18095	Hose 3/8" x 42" lg + 2 fittings 6U106	-	1
35	D-8664	Hose 3/8" x 159" lg + 2 fittings 6U106	2	-

8

HYDRAULIC SYSTEM (cont'd)

REF.	PART #	DESCRIPTION	QTY	
			P-6200	P-6300
35	D-8751	Hose 3/8" x 166" lg + 2 fittings 6U106	-	2
36	D-18103	Hose 3/8" x 60" lg + 2 fittings 6U106	2	-
36	D-18104	Hose 3/8" x 66" lg + 2 fittings 6U106	-	1
37	25TR04	Cylinder 2 1/2" x 4"	1	1
38	20G72	Cylinder 2" x 72" stroke from serial number 1195 to 1304 (see details page 32)	2	2
38	20I72	Cylinder 2" x 72" stroke from serial number 1305 and over (see details page 32)	2	2
39	Std.	Fitting 9255 6x6	2	2
40	D-8964	Hose 3/8" x 158" lg + 2 fittings 6U106	1	-
40	D-18105	Hose 3/8" x 168" lg + 2 fittings 6U106	-	1
41	D-8965	Hose 3/8" x 164" lg + 2 fittings 6U106	1	-
41	D-18106	Hose 3/8" x 170" lg + 2 fittings 6U106	-	1
42	D-18107	Hose 3/8" x 63" lg + 2 fittings 6U106	1	1
43	D-18108	Hose 3/8" x 68" lg + 2 fittings 6U106	1	1
44	D-8986	Hose 1/2" x 53" lg + 2 fittings 8U106	1	1
45	Std.	Fitting 9405 x 6 x 8	1	1
46	Std.	Street elbow 1/2" 90° C3409 x 8	1	-
46	Std.	Fitting 9405 8x8	-	1
47	Std.	Fitting 9315 6x6	12	12
48	Std.	Fitting 9355 6x8	1	1
49	Std.	Fitting 9405 8x8	2	2
50	32110	1 spool valve SD4 modified (see details page 35)	1	1

HYDRAULIC STEERING OPTION

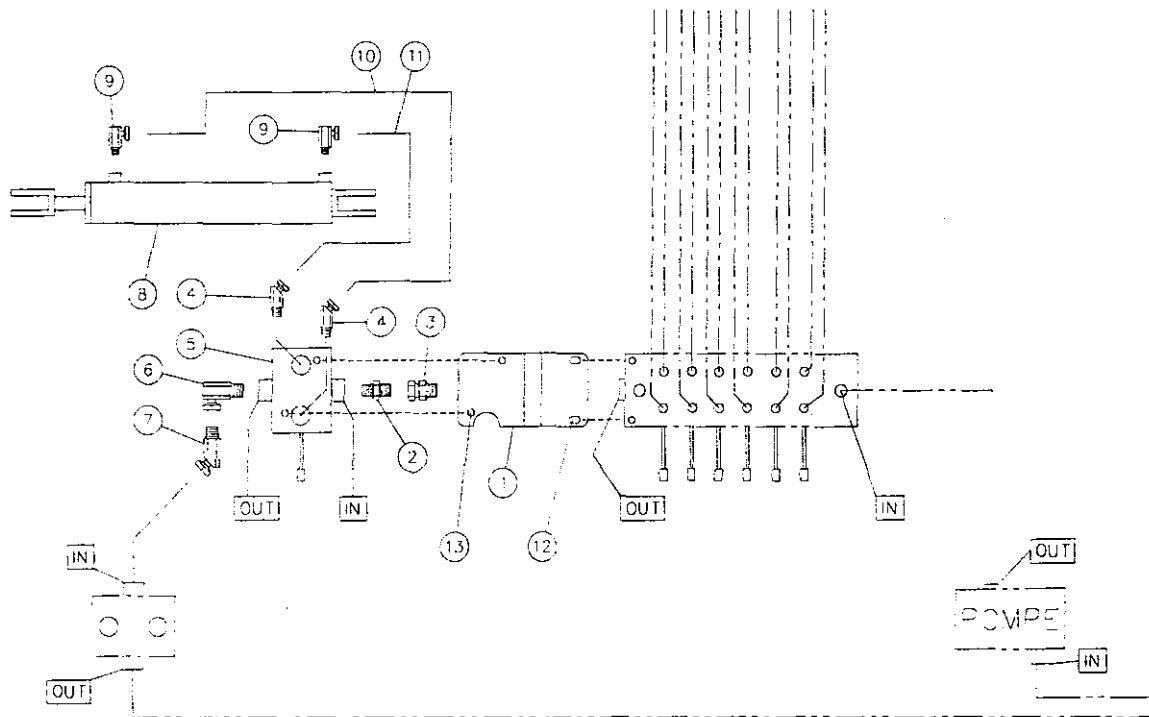







8

REF.	PART #	DESCRIPTION	QTY
1	32137	Support plate	1 1
2	Std.	Fitting C3069 x 8	1 1
3	Std.	Fitting 9315 8x8 (supplied on 6 spool valve)	1 1
4	Std.	Fitting 9355 8x8	2 2
5	32138	1 spool valve SD4 standard (see details page 34)	1 1
6	Std.	Fitting 9405 8x8	1 1
7	Std.	Fitting 9355 8x8	1 1
8	25TR08	Cylinder 2 1/2" x 8" stroke	1 1
9	Std.	Fitting 9405 6x6	2 2
10	D-8985	Hose 3/8" x 138" lg + 2 fittings 6U106	1 -
10	D-18084	Hose 3/8" x 133" lg + 2 fittings 6U106	- 1
11	D-8984	Hose 3/8" x 120" lg + 2 fittings 6U106	1 -
11	D-18085	Hose 3/8" x 122" lg + 2 fittings 6U106	- 1
12	Std.	Flat washer 5/16" (Use existing screws on 6 spool valve)	2 2
13	Std.	Bolt 5/16" NC x 2" lg + nut & lock washer	2 2





P-6200
P-6300

TORQUE CHART

TORQUE SPECIFICATION TABLE

Thread UNC and UNF		Grade 2 				Grade 5   				Grade 8*   			
Bolt size		Torque				Torque				Torque			
Inches	mm	Pound feet min.	Pound feet max.	Newton meters min.	Newton meters max.	Pound feet min.	Pound feet max.	Newton meters min.	Newton meters max.	Pound feet min.	Pound feet max.	Newton meters min.	Newton meters max.
1/4	6.35	5	6	6.8	8.13	9	11	12.2	14.9	12	15	16.3	30.3
5/16	7.94	10	12	13.6	16.3	17	20.5	23.1	27.8	24	29	32.5	39.3
3/8	9.53	20	23	27.1	31.2	35	42	47.5	57.0	45	54	61.0	73.2
7/16	11.11	30	35	40.7	47.4	54	64	73.2	86.8	70	84	94.9	113.9
1/2	12.70	45	52	61.0	70.5	80	96	108.5	130.2	110	132	149.2	179.0
9/16	14.29	65	75	88.1	101.6	110	132	149.2	179.0	160	192	217.0	260.4
5/8	15.88	95	105	128.7	142.3	150	180	203.4	244.1	220	264	298.3	358.0
3/4	19.05	150	185	203.3	250.7	270	324	366.1	439.3	380	456	515.3	618.3
7/8	22.23	160	200	216.8	271.0	400	480	542.4	650.9	600	720	813.6	976.3
1	25.40	250	300	338.8	406.5	580	696	786.5	943.8	900	1080	1220.4	1464.5
1 1/8	25.58	-	-	-	-	800	880	1084.8	1193.3	1280	1440	1735.7	1952.6
1 1/4	31.75	-	-	-	-	1120	1240	1518.7	1681.4	1820	2000	2467.9	2712.0
1 3/8	34.93	-	-	-	-	1460	1680	1979.8	2278.1	2380	2720	3227.3	3688.3
1 1/2	38.10	-	-	-	-	1940	2200	2630.6	2983.2	3160	3560	4285.0	4827.4

* Thick nuts must be used with grade 8 bolts.

Size of screw	Thread	Pitch (mm)	Grade 4T  				Grade 7T 				Grade 8T  			
			Torque				Torque				Torque			
			Pound feet min.	Pound feet max.	Newton meters min.	Newton meters max.	Pound feet min.	Pound feet max.	Newton meters min.	Newton meters max.	Pound feet min.	Pound feet max.	Newton meters min.	Newton meters max.
M6	UNC	1.00	3.6	5.8	4.9	7.9	5.8	9.4	7.9	12.7	7.2	10	9.8	13.6
M8	UNC	1.25	7.2	14	9.8	19	17	22	23	29.8	20	26	27.1	35.2
M10	UNC	1.5	20	25	27.1	33.9	34	40	46.1	54.2	38	46	51.5	62.3
M12	UNC	1.75	28	34	37.9	46.1	51	59	69.1	79.9	57	66	77.2	89.4
M14	UNC	2.0	49	56	66.4	75.9	81	93	109.8	126	96	109	130.1	147.7
M16	UNC	2.0	67	77	90.8	104.3	116	130	157.2	176.2	129	145	174.8	196.5
M18	UNC	2.0	88	100	119.2	136	150	168	203.3	227.6	175	194	237.1	262.9
M20	UNC	2.5	108	130	146.3	176.2	186	205	252	277.8	213	249	288.6	337.4
M8	UNF	1.0	12	17	16.3	23	19	27	25.7	36.6	22	31	29.8	42
M10	UNF	1.25	20	29	27.1	39.3	35	47	47.4	63.7	40	52	54.2	70.5
M12	UNF	1.25	31	41	42	55.6	56	68	75.9	92.1	62	75	84	101.6
M14	UNF	1.5	52	64	70.5	86.7	90	106	122	143.6	107	124	145	168
M16	UNF	1.5	69	83	93.5	112.5	120	138	162.6	187	140	158	189.7	214.1
M18	UNF	1.5	100	117	136	158.5	177	199	239.8	269.6	202	231	273.7	313
M20	UNF	1.5	132	150	178.9	203.3	206	242	279.1	327.9	246	289	333.3	391.6

Use the above torques when special torque is not given.

NOTE: These values apply to fasteners as received from supplier, dry, or when lubricated with normal engine oil. They do not apply if extreme pressure lubricants are used.



WARRANTY

PRONOVOST warrants this product to the initial purchaser for the period of one year from the date of purchase against defects in materials and workmanship.

We will replace or repair defective parts free of charge if they are returned to our plant in St-Tite, Quebec, Canada.

Transportation charges are the responsibility of the customer. This warranty is not transferable.

Tires and gasoline engine are covered by the manufacturers of these items.

All PRONOVOST spare parts purchased are covered by a three (3) month warranty.

This warranty becomes void and nul if the equipment is modified, breaks down as result of an accident, if not operated according to manufacturer's recommendations, damaged by negligence or if maintenance has not been carried out as specified.

Our obligation is limited to the replacement or repair of the defective part. PRONOVOST accepts no responsibility for direct or indirect consequential damages of any kind.

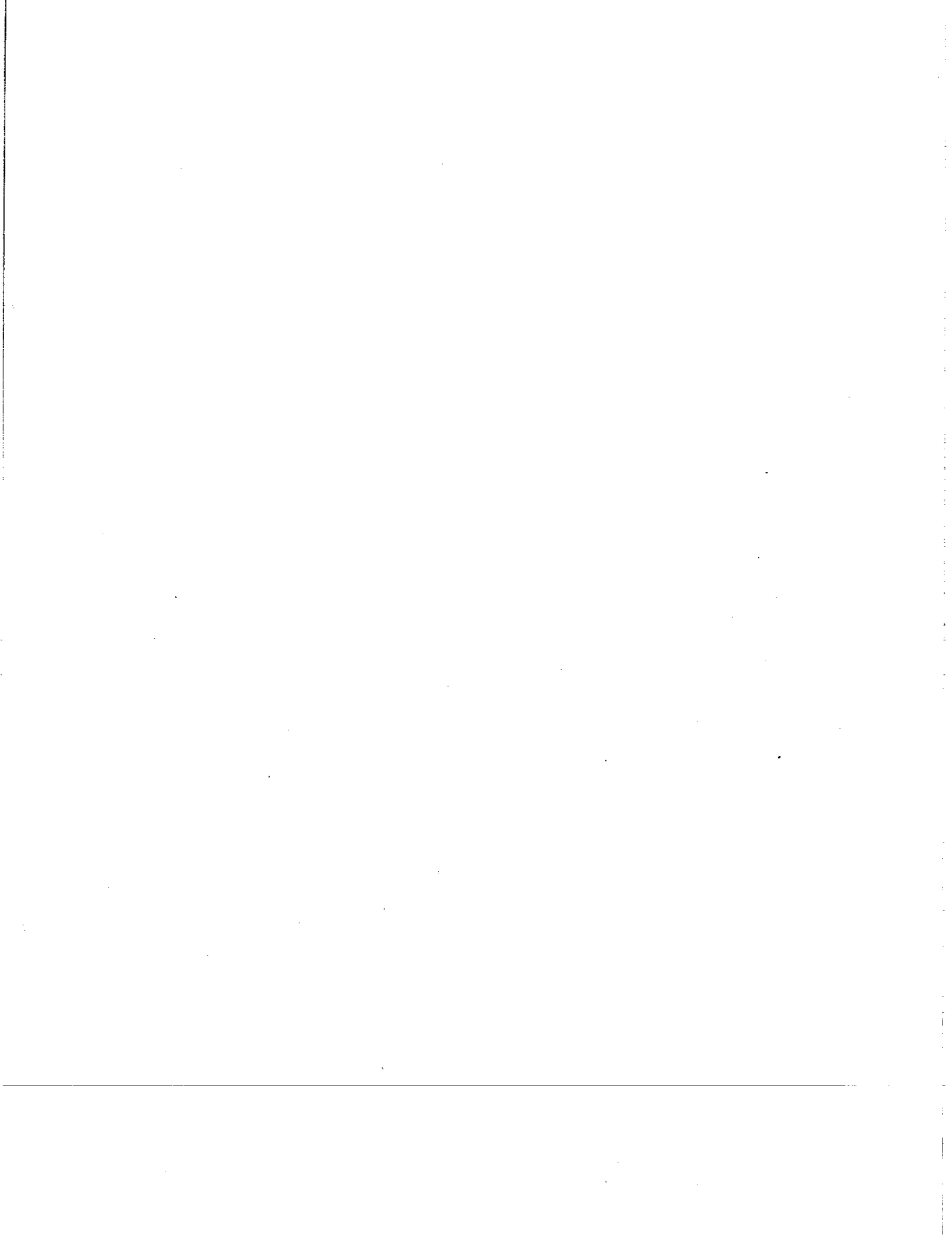

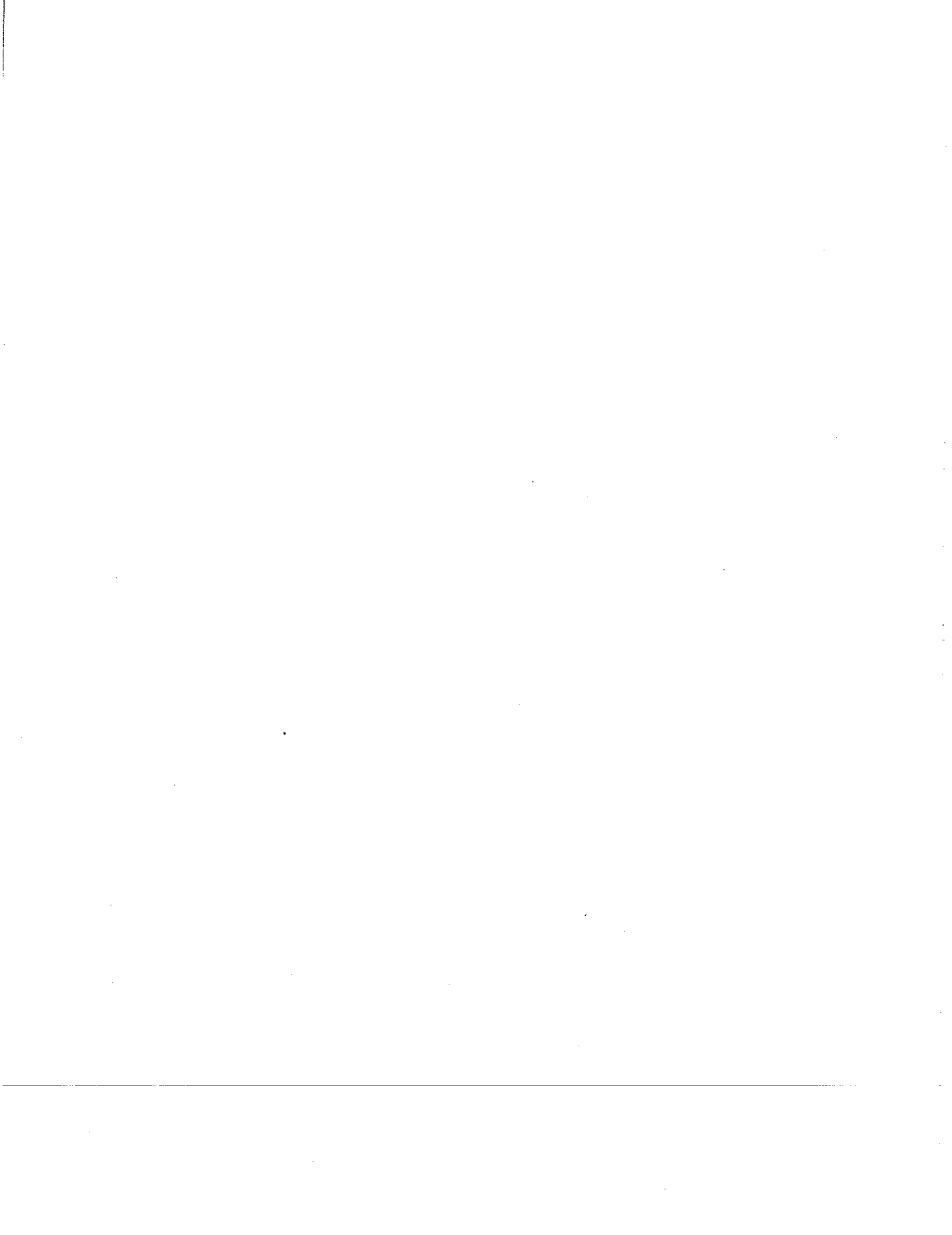

Ce manuel est aussi disponible en français.
Veuillez téléphoner.



INNOVATION - EXCELLENCE

LES MACHINERIES PRONOVOST INC.
260, route 159,
Saint-Tite, Quebec, Canada, G0X 3H0
Tel.: (418) 365-7551, Fax: (418) 365-7954