

**Alberta  
Ag-Industries Ltd.**

**OWNER'S  
MANUAL**

**Agripac<sup>®</sup>  
Lastic Tuber<sup>™</sup>**

**Model 9200**

**Alberta  
Ag-Industries Ltd.**

10012 - 93 Ave.,  
Westlock, AB, T7P 2P2  
Phone: 1-800-661-4150, Fax: (403) 349-4741

# TABLE OF CONTENTS

Section	Item	Page
1	<b>Introduction</b> .....	<b>5</b>
2	<b>Safety</b> .....	<b>6</b>
	General Safety .....	6
	Safety in Operation .....	6
	Safety with Maintenance .....	7
	Safety in Transport .....	7
	Safety in Storage .....	7
3	<b>Decals</b> .....	<b>8</b>
	Safety Decals .....	8
	Maintenance Decals .....	9
4	<b>Start-up</b> .....	<b>10</b>
	Basic Start-up Procedures .....	10
	Ground Preparation .....	12
	Operation for square bales .....	13
	Adjustment of Agripac® Lastic Tuber™ .....	13
	Operation .....	15
	Operation for round bales .....	22
	Adjustment of Agripac® Lastic Tuber™ .....	22
	Operation .....	25
5	<b>Maintenance</b> .....	<b>29</b>
6	<b>Storage</b> .....	<b>30</b>
7	<b>Specifications</b> .....	<b>31</b>
8	<b>Parts List</b> .....	<b>32</b>
	Detail of Arch (Model 9200) .....	32
	Arch Cylinder (Model 9200) .....	33
	Lateral Cylinder .....	34
	Cylinder 20TR24 .....	35
	Cylinder 25TR04 .....	36
	Cylinder 30TR04 .....	37
	Pusher hydraulic motor .....	38
	Hydraulic motor for motorized moving kit DH400 .....	39
	Control valve 1, 2, 3, 4 & 6 spool .....	40
	Double pump MHP-22 .....	41
	Engine Assembly with Pump .....	42
	Hub H2500 .....	43
	Hydraulic System .....	44
	Electric System .....	47
	Electric Circuit .....	49
9	<b>Torque Chart</b> .....	<b>50</b>
10	<b>Warranty</b> .....	<b>51</b>



---

---

# INTRODUCTION

---

1

## CONGRATULATIONS!

Thank you for choosing ALBERTA AG-INDUSTRIES LTD. We are confident this equipment will meet your requirements in terms of quality, performance and reliability.

This manual was prepared to assist you in the safe operation of your new Agripac® Lastic Tuber™. It contains important information which will help you achieve excellent returns with your tubing-machine for years to come.

Please read this manual completely before operating your Agripac® Lastic Tuber™ and keep it for future reference.

Before starting the machine, you or any other person who will be operating the Agripac® Lastic Tuber™ must familiarize yourself with the safety recommendations and the operating instructions. Please read carefully and be sure to understand and follow all recommendations and procedures.

In this manual, the right and left sides of the Agripac® Lastic Tuber™ are identified while standing at the discharge end of the machine and facing it.

If you require additional information on your Agripac® Lastic Tuber™, please contact your ALBERTA AG-INDUSTRIES LTD. Dealer.

**NOW** take a moment to enter the model, serial number and the date of purchase of your Agripac® Lastic Tuber™ in the space provided.

When ordering parts from your Dealer, please refer to these numbers for a fast and efficient service. Use ALBERTA AG-INDUSTRIES LTD. parts for replacement.

The model and serial numbers are on the nameplate shown on Fig. 1.

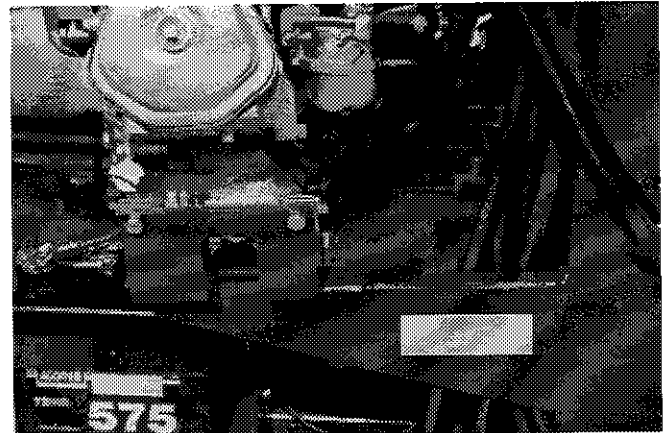

Figure 1

MODEL: \_\_\_\_\_

SERIAL NO.: \_\_\_\_\_

DATE OF PURCHASE: \_\_\_\_\_

---

---

# SAFETY

---

## GENERAL SAFETY

### WHEN YOU SEE THIS SYMBOL

2



**ATTENTION!**

**BE ALERT  
YOUR SAFETY IS INVOLVED**

This symbol «SAFETY ALERT» is used in this manual and on the safety decals on the Agripac® Lastic Tuber™. It warns you of the possibility of danger. Carefully read, understand and follow all safety recommendations before operating the Agripac® Lastic Tuber™.

- 1) Careful operation is the best assurance against accidents. Carefully read this manual and the motor manual and follow all recommendations before operating your Agripac® Lastic Tuber™. It is the owner's responsibility to make sure that anyone who will operate the Agripac® Lastic Tuber™ will read these manuals before operating the equipment.
- 2) Never let a child operate the Agripac® Lastic Tuber™.
- 3) Do not modify the Agripac® Lastic Tuber™. Any non authorized modification may affect the efficiency and/or safety of the equipment.
- 4) Never operate the Agripac® Lastic Tuber™ with defective parts or if damaged in any way. Have it repaired before operating.
- 5) Make sure all fasteners are in place and properly secured or tightened. Refer to torque chart on page 50.

- 6) Avoid wearing loose fitting clothing when working with the Agripac® Lastic Tuber™. These could get entangled in moving parts of the equipment and cause accidents.
- 7) Keep motor clean and exempt of dust and debris.
- 8) Before using the Agripac® Lastic Tuber™, inspect the area where it is to be used and remove any object which could hamper normal operation or damage the plastic tube.
- 9) Hydraulic fluids under pressure can damage your skin. Do not use your hands to locate a leak.
- 10) Plastic bags are impervious to air. Keep them away from children to avoid suffocation.
- 11) When using a tractor equipped with a spear, be extremely careful. Always lower the spear to the ground before leaving your tractor.
- 12) Do not store, spill or use fuel near a flame, a hot engine or stove.

## SAFETY IN OPERATION

- 1) Position the engine outward before you start working with the Agripac® Lastic Tuber™.
- 2) Be sure there are no obstructions around the equipment and that no one stands near the Agripac® Lastic Tuber™ when in operation.
- 3) Always refuel equipment when outside and away from flames or sparks.
- 4) Never run the engine inside. Do not operate the engine in a confined or non ventilated area. Carbon monoxide is a colorless, odorless and deadly gas.
- 5) Be careful when adjusting equipment with engine running.

---

---

## ***SAFETY (cont'd)***

---

- 6) Keep hands, feet, hair and clothing away from moving parts.
- 7) Should you need to step onto the Agripac® Lastic Tuber™ for whatever reasons, **ALWAYS** stop the motor since there is **RISK OF SERIOUS INJURY** if not stopped.
- 8) Do not refill fuel tank with engine running. Always let the engine cool off for a couple of minutes before refilling. Always use approved fuel containers.
- 9) Do not operate the engine if fuel is spilled. Move equipment away from the spill and avoid any spark until the complete evaporation of the fuel.
- 10) Do not smoke while refueling.
- 11) Do not operate engine with any accumulation of hay, leaves, dirt or any other combustible material near the exhaust muffler.
- 12) Avoid touching the hot muffler and cooling fins since they could cause burns to your skin.
- 2) Slide the engine to the inward position (transport position) in order not to exceed the legal width on the road.
- 3) Check local regulations for the transport of your Agripac® Lastic Tuber™ on the road.
- 4) Be alert when pulling the Agripac® Lastic Tuber™ on the road. Do not allow anyone to stand on it while in motion.
- 5) The road speed should be such as to maintain full control over steering and braking.
- 6) Be careful while backing up.

### ***SAFETY IN STORAGE***

- 1) Let engine cool and drain fuel from tank.
- 2) Do not let children play in the area where the Agripac® Lastic Tuber™ is stored.
- 3) Do not leave a Tube installed on the Agripac® Lastic Tuber™.
- 4) Do not let the Agripac® Lastic Tuber™ stand on the tires. Lower it to the ground or on wooden blocks. **THIS WILL AVOID ANY ACCIDENTAL CRUSHING OF ANIMALS OR ANYONE WHO COULD CRAWL UNDER THE EQUIPMENT.**

### ***SAFETY WITH MAINTENANCE***

- 1) Perform the Agripac® Lastic Tuber™ maintenance according to the recommendations contained in this manual.
- 2) Stop engine and relieve all hydraulic pressures before doing inspection, maintenance or repairs.
- 3) Do not check spark with spark plug or wire removed. Use the appropriate testing equipment.
- 4) Regularly check fuel lines and fittings for leaks. Replace if necessary.

### ***SAFETY IN TRANSPORT***

- 1) Be sure to engage the two safety locks (A Figure 2) provided for the rear wheels hydraulic cylinders (B Figure 2).

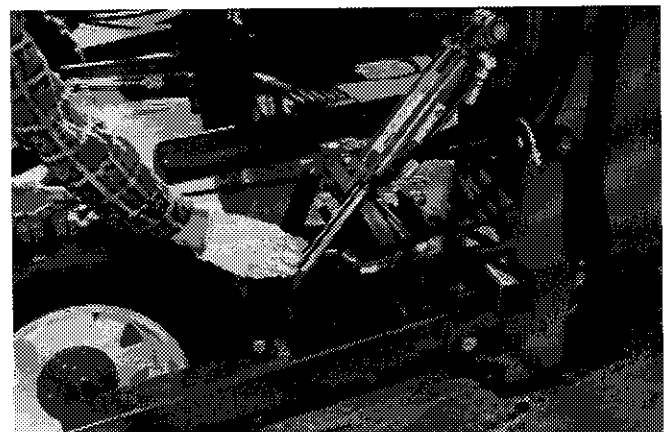

Figure 2

# DECALS

## SAFETY DECALS

The safety decals are affixed wherever special safety precautions are indicated. Locate them on the machine and read them carefully. If a decal is damaged, lost or illegible, install a new one. Each decal is identified with a letter and part number. The following photos indicate where each one must be installed.

3

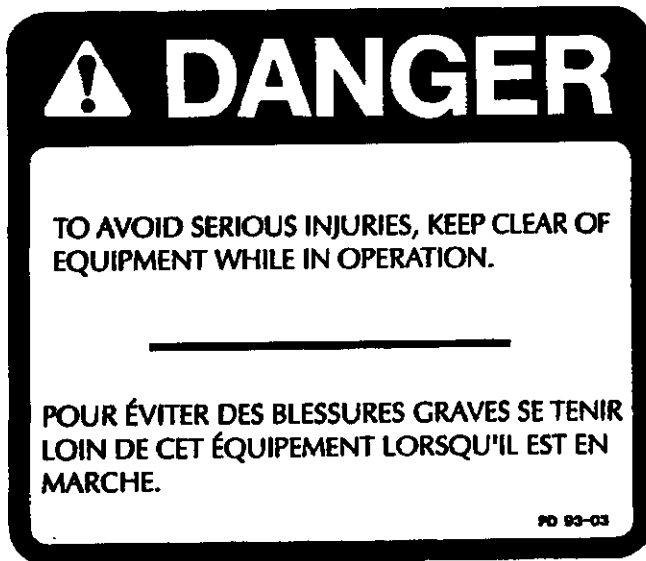

Figure 3  
Decal A

Part no.: A101

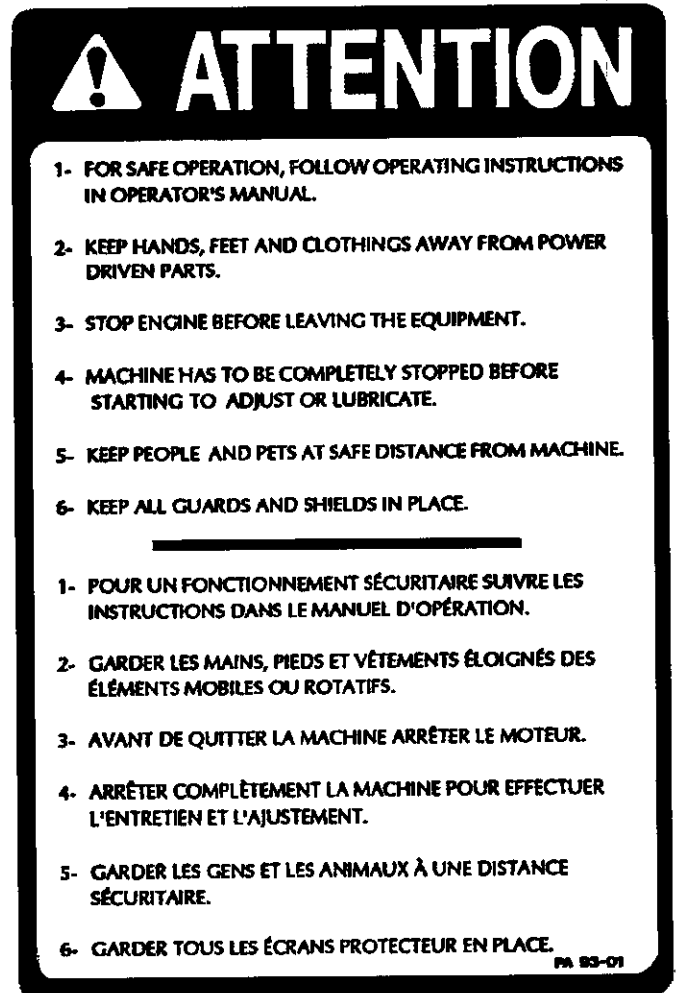

Figure 5  
Decal B

Part no.: A102

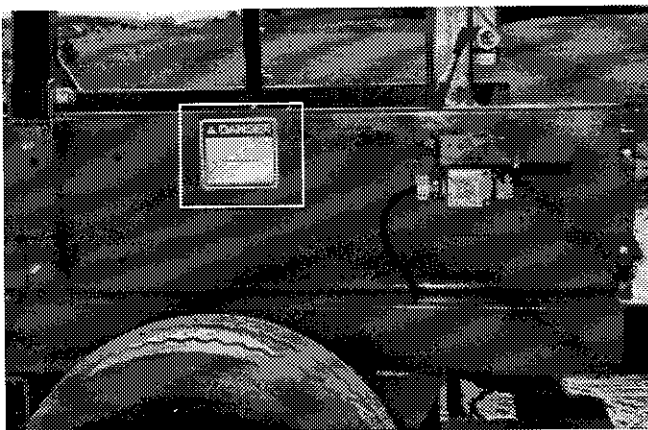

Figure 4

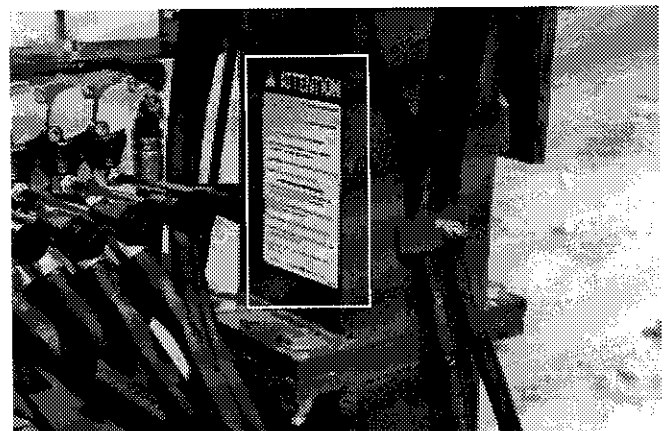

Figure 6



## DECALS (cont'd)



Figure 7  
Decal C

Part no.: A103



Figure 8

### MAINTENANCE DECALS

The maintenance decals indicate the points requiring lubrication. Refer to the maintenance section for more details.



Figure 9

Part no.: A104



Figure 10

3

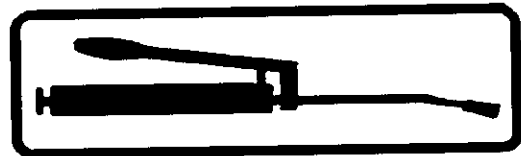

Figure 11

Part no.: A 106

---

# OPERATION

---

4

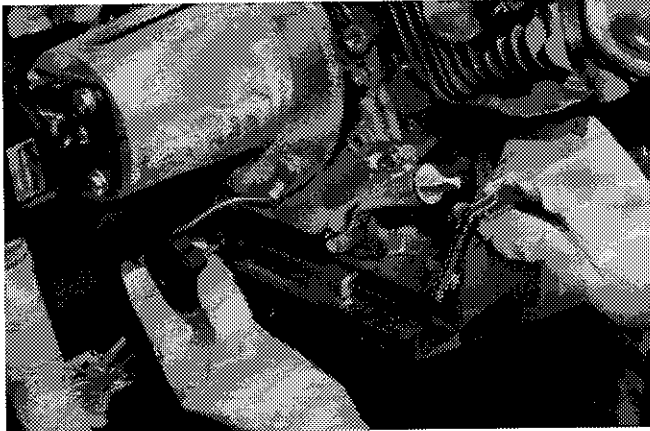

Figure 12



Figure 13



Figure 14

## ***BASIC START-UP PROCEDURES***

- 1) The Agripac® Lastic Tuber™ engine is mounted on a sliding base so it can be easily placed in transport position in order not to exceed the legal width on the road. Do not forget to re-position the engine outward before starting (Fig. 12).
- 2) Verify for adequate tightness of all fastening devices. Refer to torque chart on page 50.
- 3) Lubricate all points and guide mechanisms requiring grease, with a high quality lithium base grease containing molybdenum disulfide (MoS<sub>2</sub>) such as «Esso Unirex EP1 Moly», «DARINA XL-Multi Season Moly, Grade #1» from Shell or equivalent.
- 4) Check oil level in hydraulic reservoir. Use good quality tractor transmission and hydraulic system oil such as «Trans Hydraulic Duratran» from Petro Canada, «DONAX TD» from Shell or equivalent.
- 5) Check tire pressure and adjust according to recommendation indicated on the tires.
- 6) Check engine oil level.
- 7) Check the operation of all hydraulic cylinders.
- 8) Check the operation of the bale pusher mechanism. It must operate freely and return to its starting position automatically.
- 9) If your Agripac® Lastic Tuber™ is equipped with the hydraulic U-shaped bales guide, check if it operates well. If needed, readjust the two halves of the bale guide in order to maintain them parallel. It can be done by taking off the central part (Fig. 13) and by turning the adjustments (Fig. 14).

# OPERATION (cont'd)

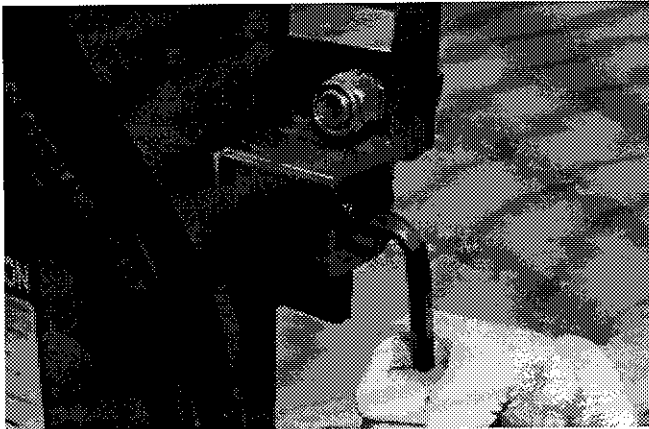

Figure 15

10) There is one adjustment for each lateral stretcher. It helps to reduce the friction due to torsion when stretching the tube. It is important not to apply an excessive tension on these adjustments (Fig. 15).

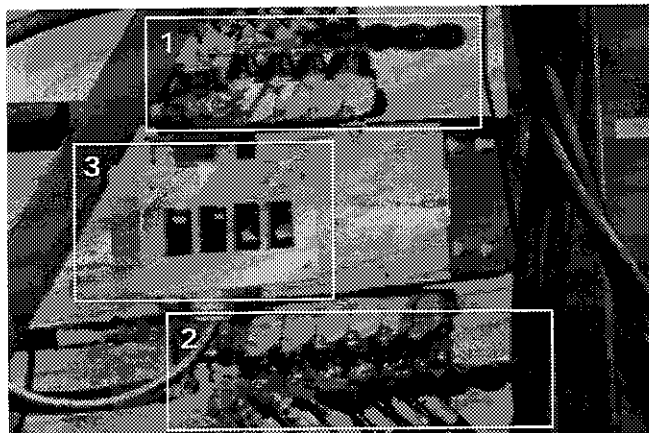

Figure 16

11) Your Agripac® Lastic Tuber™ has hydraulic manual controls (1 & 2 Fig. 16), electrohydraulic controls for some functions (3 Fig. 16), and a remote control (Fig. 17) from which you can control the main functions. The **grey button makes the pusher move forward**. The **red button stops the pusher and returns it to its starting position**. The **yellow button makes the Agripac® Lastic Tuber™ turn to the left side** and the **green button to the right side**.

12) The control box on the Agripac® Lastic Tuber™ (Fig. 18) controls the following functions. From left to right, the **first button turns on the hydraulic system**. The **second button selects the pusher operation mode manual or automatic** (when the pusher moves forward and returns to its starting position automatically). The **third button moves the pusher forward or backward**. The **fourth button turns the Agripac® Lastic Tuber™ to the left or to the right**.

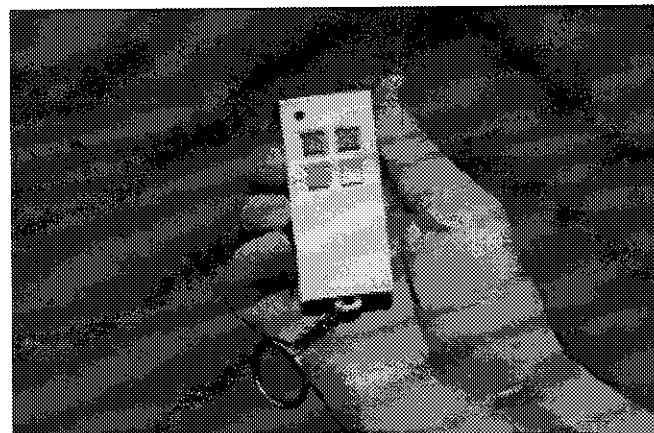

Figure 17

13) There are two limit switches (Fig. 19), they are used to adjust the length of travel of the pusher in automatic mode.

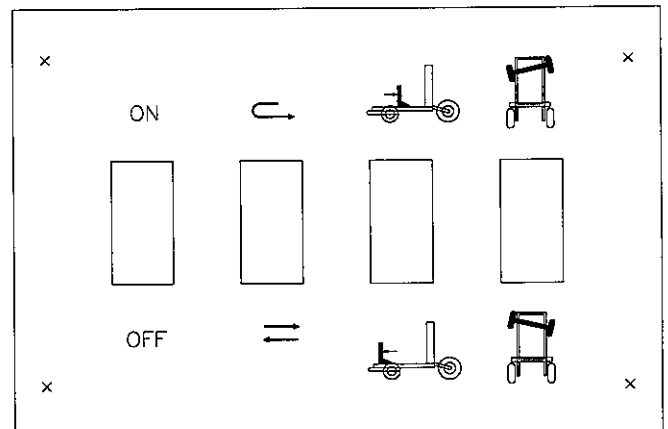

Figure 18

---

## OPERATION (cont'd)

---

4



Figure 19



Figure 20



Figure 21

- 14) Check the surface of the stretcher arms for smoothness. Any mark or protrusion could cause the tube to tear.
- 15) A motorized moving kit is available as an option. Place the lever downward and put the clevis in place to disengage the traction (Fig. 20).
- 16) Place the lever upward (Fig. 21) to engage the traction and operate the corresponding control valve to move the Agripac® Lastic Tuber™ forward or backward. **WARNING: put the lever back into the disengaged position after each displacement because there is a risk of serious damage if you move the Agripac® Lastic Tuber™ with an other vehicle or when it moves forward when operating.**

### GROUND PREPARATION

- 1) Choose a dry and well drained area.
- 2) Level and clean up site where the tubes will be used.
- 3) If possible, provide a sand bed of 2" to 3" (5-8 cm.) thick. This will help reduce damage from rodents.



Figure 22

## OPERATION FOR SQUARE BALES (cont'd)

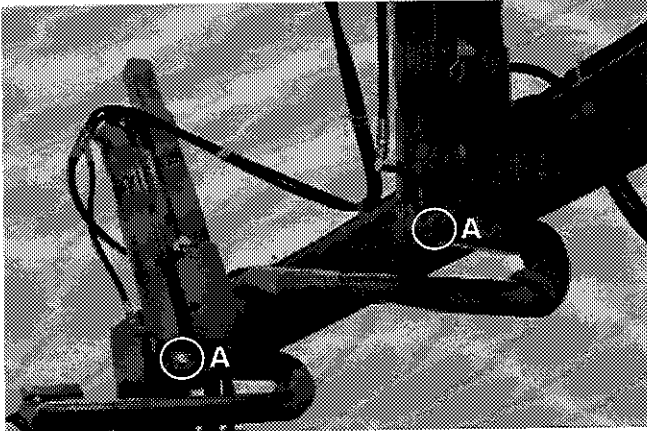

Figure 23



Figure 24

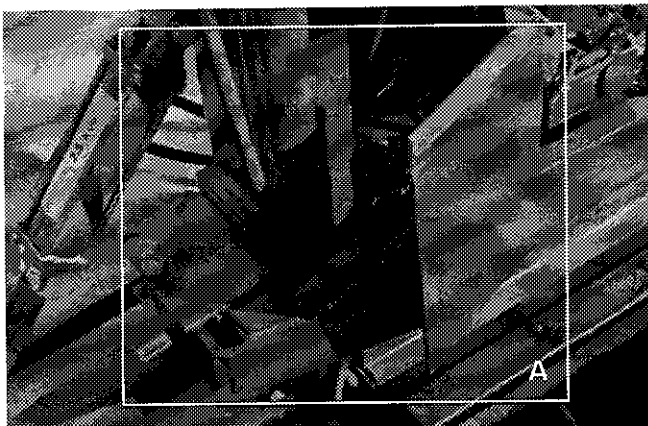

Figure 25

### SQUARE BALE TUBING

#### ADJUSTEMENT OF AGRIPAC® LASTIC TUBER™

- 1) Your Agripac® Lastic Tuber™ is designed to bale-tubing square silage bales. The U-shaped bale guide is adjustable from 36" to 60" (91 cm to 152 cm) width and the free height from 37" to 72" (94 cm to 183 cm).
- 2) We recommend to adjust the bales length between 60" and 63" (152 cm to 183 cm). **NEVER exceed 65" (165 cm) long** because it could cause tears to the tube. The bale will be placed crosswise to the machine. One or more stacked bales can be placed on the Agripac® Lastic Tuber™ but they must never exceed 72" (183 cm) high.
- 3) If the Agripac® Lastic Tuber™ is equipped with the round bale option, the upper stretcher arms (Fig. 23) must be removed to obtain the maximum free height. Take off the two clevis (A Fig. 23) and remove the stretchers. The bottom stretchers must be adjusted to the outside hole. (Fig. 24)
- 4) If not equipped with round bale option, the two guides (A Fig. 25) must be installed as shown to protect the plastic tube.
- 5) The U-shaped bale guide must be adjusted to its largest dimension (Fig. 26).

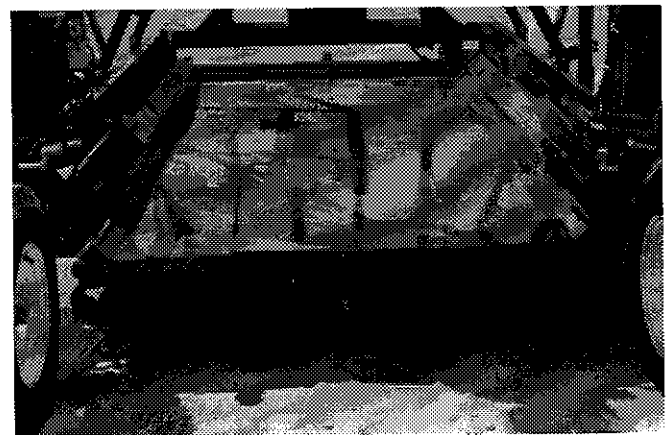

Figure 26

---

## OPERATION FOR SQUARE BALES (cont'd)

---

4

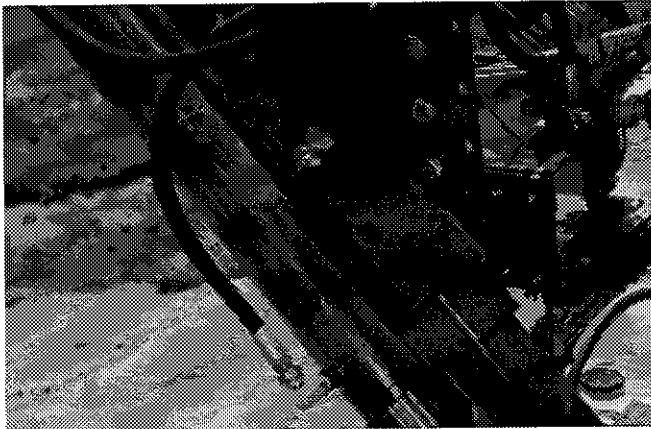

Fig. 27

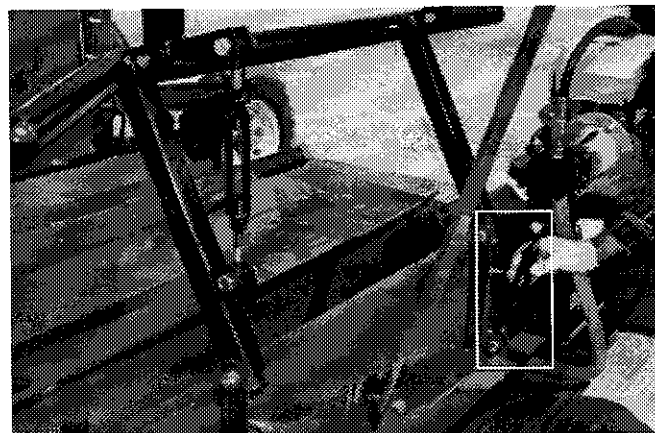

Figure 28



Figure 29

- 6) The two lateral stretchers must be adjusted to the central position as shown (Fig. 27). However it is possible to adjust them at the outside position if the bales are excessively big.
- 7) Use turnbuckles provided (Fig. 28) to adjust lower guide according to the width of the bales (Fig. 29). It is important that the bales are centered on the machine.
- 8) Use turnbuckles provided (Fig. 30) to adjust upper guide to the same dimension.
- 9) Locate the rear end of the Agripac® Lastic Tuber™ approximately 5' (152 cm) away from the point where you want to position the end of the tube. This will compensate if there is some slippage of the first couple of bales until there is enough ground friction to push the Agripac® Lastic Tuber™ forward.
- 10) The Agripac® Lastic Tuber™ can be operated with the tongue assembly on. If there is a risk of interference with the front of the tractor or with uneven ground, it is recommended to remove it (Fig. 31).



Figure 30

---

## OPERATION FOR SQUARE BALES (cont'd)

---

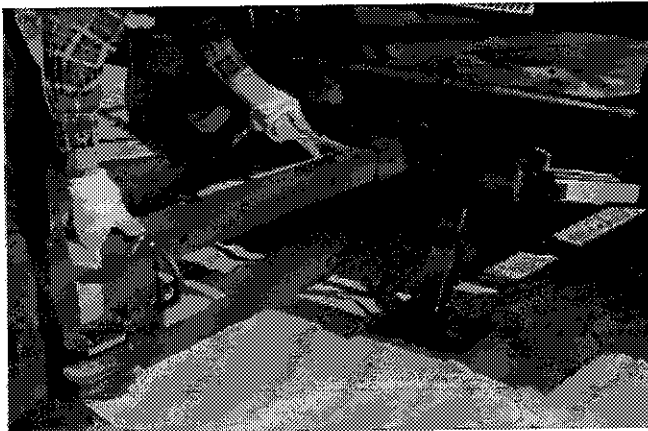

Fig. 31

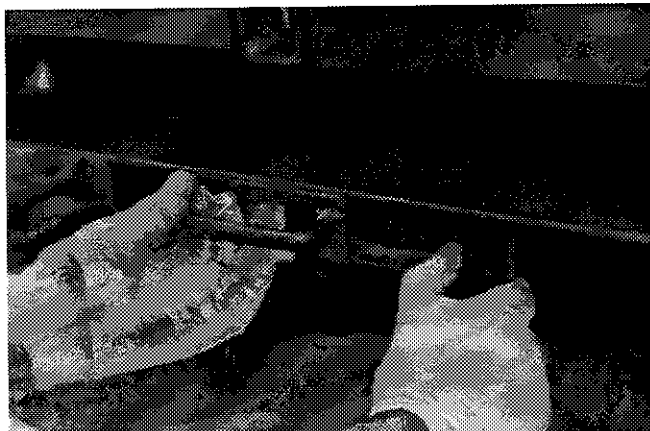

Figure 32

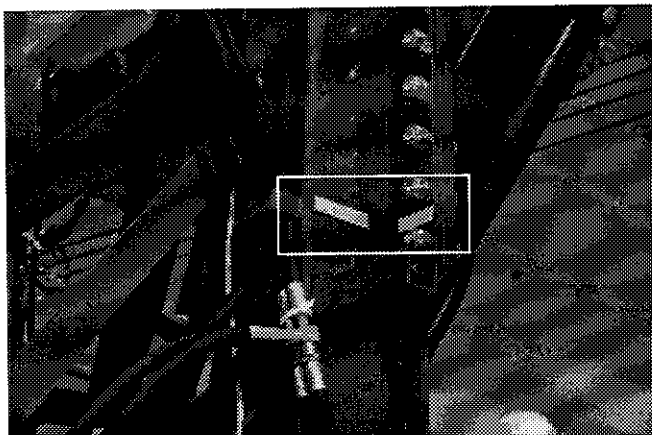

Figure 33

- 11) For maximum operating speed, you may set the engine to full throttle, although it is preferable to run it a speed closer to your rate of bale supply to machine. This will result in a more economical operation.

### OPERATION

- 1) Start engine.
- 2) Pull out the tube support plate (Fig. 32).
- 3) Adjust the height of the two lateral stretchers to the upper yellow mark (Fig. 33).
- 4) Remove the tube from its box, lay it flat on the ground and roll up the two ends towards center. Place the tube at the center of the support plate and unroll each side. Place it so that the tube name is facing outside when it unfolds (Fig. 34).



Figure 34

---

## OPERATION FOR SQUARE BALES (cont'd)

---

4



Figure 35

- 5) Close the stretcher arms to the most inward position as shown (Fig. 35 & Fig. 36) and install tube on the stretcher arms.
- 6) Slide it carefully **to the bottom** of the stretcher arms and under the U-shaped bale guide (Fig. 37).
- 7) Be careful to remove all wrinkles, since they could cause some tearing of the tube (Fig. 38).
- 8) Open the two lateral stretchers in order to apply a **slight amount of tension** to the tube (Fig. 39).



Figure 36



Figure 38



Figure 37

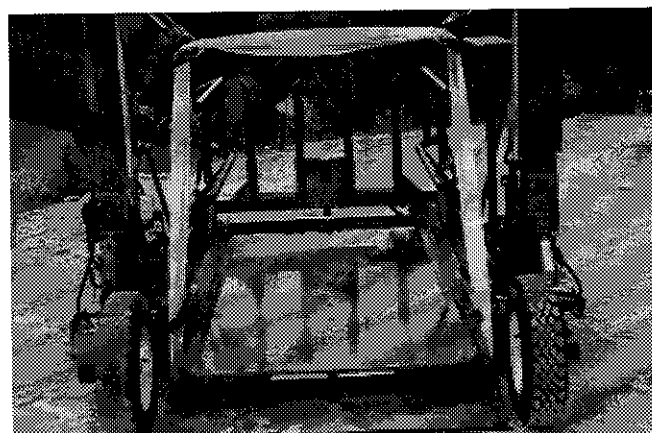

Figure 39



---

## OPERATION FOR SQUARE BALES (cont'd)

---

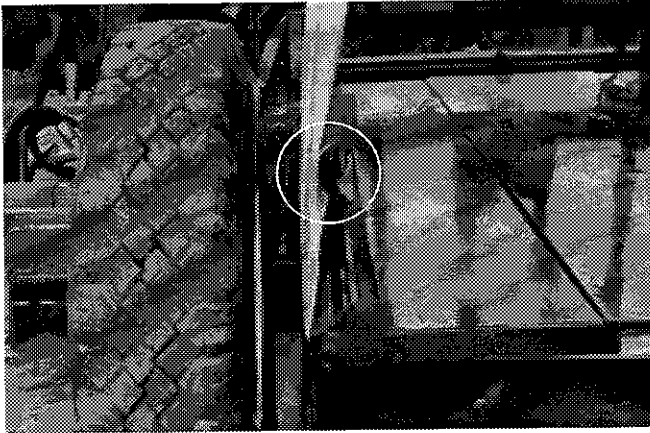

Figure 40



Figure 41



Figure 42

- 9) If the round bales option is installed on the Agripac® Lastic Tuber™, it's important to place the two bottom stretchers to avoid pressure on the plastic tube (Fig. 40). The pressure on the plastic tube is applied only when ready to operate.
- 10) Return the tube support plate to its closed position. **ATTENTION:** It is very important that you proceed to step 8 before this one because you can cause some tearing of the tube by closing the tube support plate.
- 11) Again check the tube position and eliminate any wrinkles. Next, cut off all ties as shown (Fig. 41).
- 12) Apply a light tension to the tube, pull out the outer ply of plastic for approximately 18" (45 cm) (Fig. 42) and replace it on the tip of stretchers (Fig. 43). In this way, it will be easier to pull out when it will be time to close the end of the tube.
- 13) You will finish to stretching the tube after the introduction of the first bales in the Agripac® Lastic Tuber™.



Figure 43

## OPERATION FOR SQUARE BALES (cont'd)

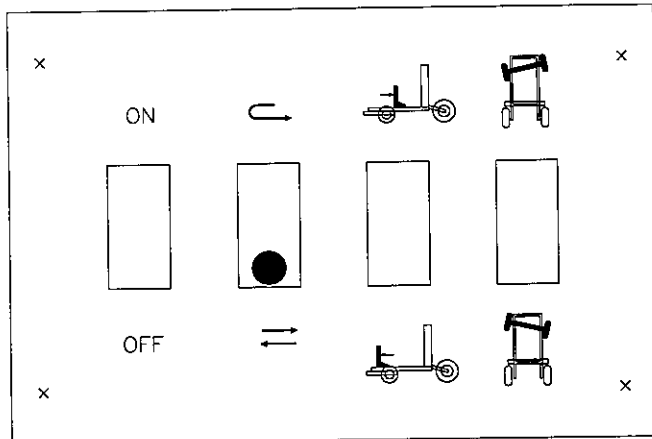

Figure 44

14) Before introducing the first bales, place the switch for the pusher on manual mode (Fig. 44).

15) A twine dispensing option is available to prevent rocking motion of the bales when they are ejected from the Agripac® Lastic Tuber™. This option is usefull when working with two or three bales high.

16) Pass the twine end under the retaining plate (A Fig. 45), through the ring (1 Fig. 45) and attach the twine end to the support ring on the opposite side (2 Fig. 46).

17) Verify and adjust the height of the rings. The twine must be equal with the center of the upper bale (Fig. 47).

18) The first step to stretch the tube is made by moving the stretchers upward. Place the bottom of the stretcher plate (see arrow) 3" higher (7.6 cm) than the total height of the bales (Fig. 48).

4

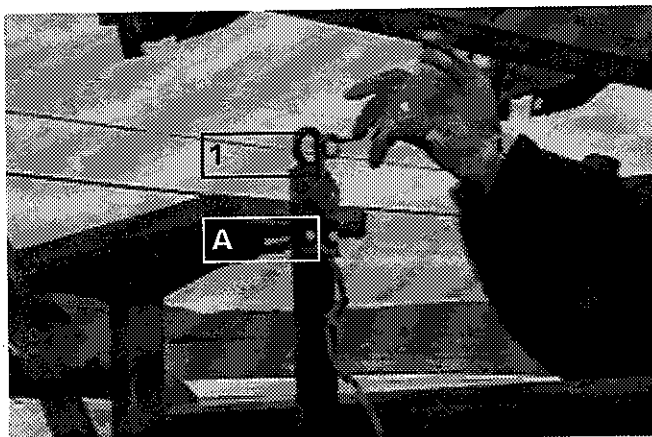

Figure 45

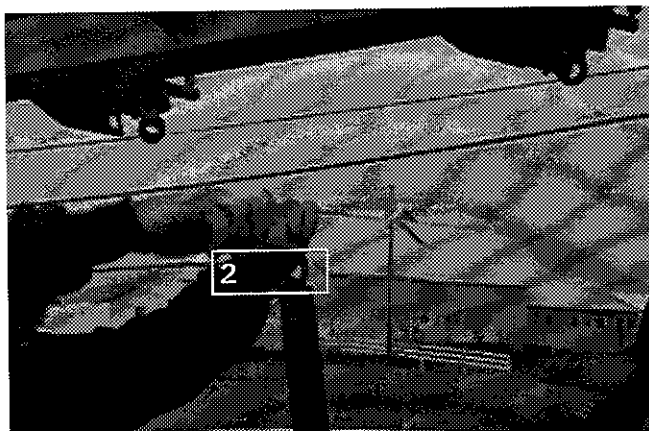

Figure 46



Figure 47

---

## OPERATION FOR SQUARE BALES (cont'd)

---

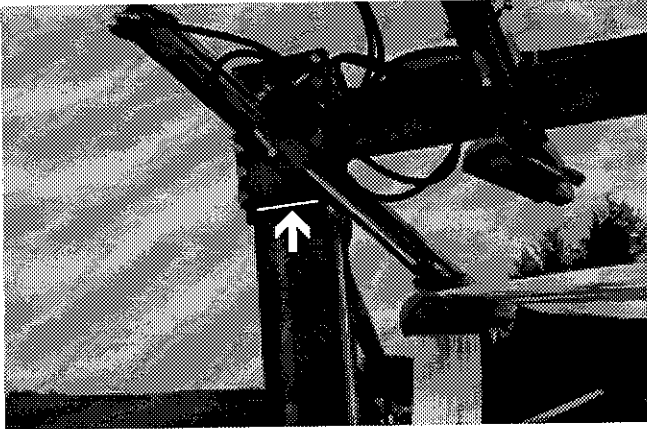

Figure 48



Figure 49

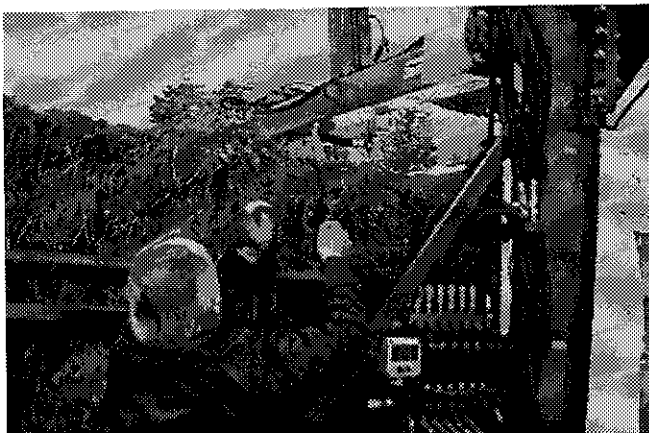

Figure 50

- 19) Second, stretch the tube enough to introduce the first stack of bales.
- 20) If needed, readjust the stretchers height (step 18).
- 21) Operate the control valve manually until the stack of bales goes beyond the stretchers ends by about 6" (15 cm) (Fig. 49).
- 22) Unhook the twine from its support (Fig. 50) and pull off the enough twine to go round the three first stacks. Cut the twine near the support and tie ends together firmly (Fig. 51).

4



Figure 51

---

## OPERATION FOR SQUARE BALES (cont'd)

---

4



Figure 52



Figure 53



Figure 54

23) **CLOSING OF THE END OF TUBE:** Let the two stretchers going inward until they touch lightly the bales (Fig. 52). In this way, the plastic will be easier to slide. Pull out enough plastic to close, and tie the tube properly as shown (Fig. 53). **Do not forget:** stretch the tube again to introduce freely the bales in the tube (Fig. 54).

24) **STRETCH THE TUBE ONLY WHEN READY TO OPERATE.** It may lose some of its capacity to retract if kept stretched for a too long period of time. If you must stop loading bales for a while, **BRING THE TUBE DOWN TO A MODERATE TENSION.**

25) Adjust rear wheels in order to have a minimum amount of ground friction with the rear end of the Agripac® Lastic Tuber™ while keeping it in contact with the ground (Fig. 55).

26) Push the switch for pusher mode to automatic mode.

27) It is recommended to use a double spear on your loader to place the bales onto the Agripac® Lastic Tuber™.



Figure 55

---

## OPERATION FOR SQUARE BALES (cont'd)

---

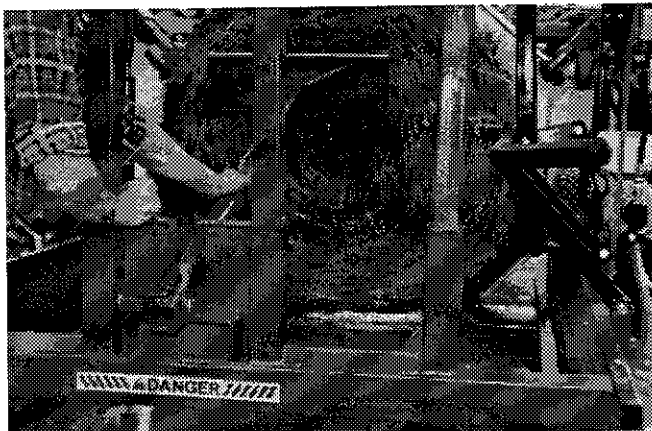

Figure 56



Figure 57



Figure 58

- 28) Place the required number of bale in each row before operate the pusher mechanism.
- 29) The pusher control and the steering option control can be controled from the remote control or from the control box.
- 30) After the first 8 or 10 bales, lift up lightly the rear wheels of the Agripac® Lastic Tuber™ to increase ground friction. This will ensure that the bales will be real tight against each other in the tube.
- 31) Towards the end of the tube, keep at least 60" (152 cm) of plastic, in order to allow for proper closure of the tube.
- 32) To push the last bale into the tube, install the pusher extension supplied with the Agripac® Lastic Tuber™. Place it as shown (Fig. 56).
- 33) Push the bale with the pusher in manual mode in order to eject the last bale from Agripac® Lastic Tuber™.
- 34) Remove the pusher extension and store it in it's receptacle on the right hand side of the Agripac® Lastic Tuber™ (Fig. 57).
- 35) Close up end of tube as previously described (Fig. 58).
- 36) Regularly inspect the tubes. If torn or punctured, repair openings with proper means.

---

---

## OPERATION FOR ROUND BALES (cont'd)

---

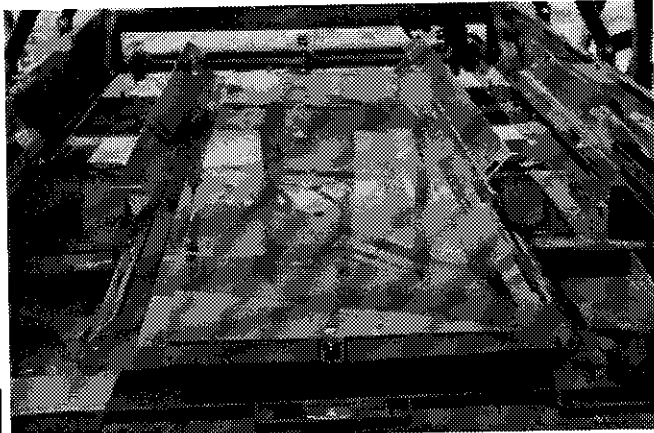

**4** Figure 59

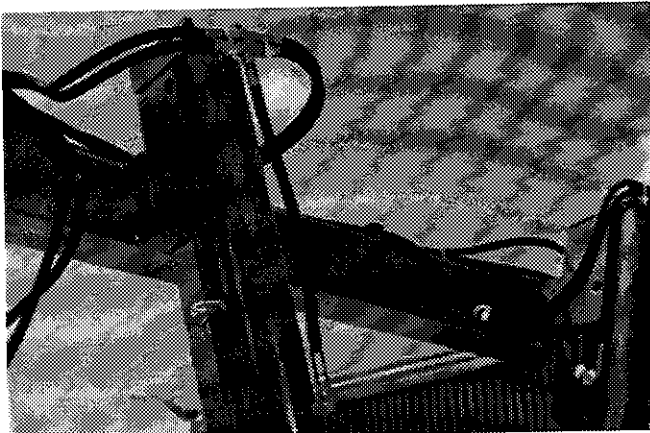

Figure 60

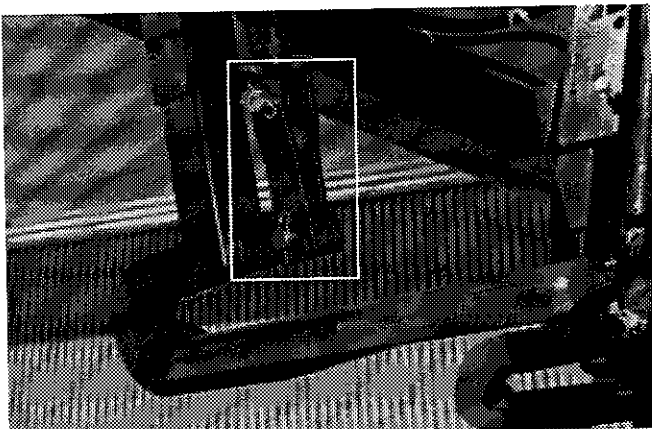

Figure 61

### ROUND BALES TUBING

#### ADJUSTMENT OF AGRIPAC® LASTIC TUBER™

- 1) An optional kit is available. It allows tubing of round silage bales from 48" to 66" (122 cm to 167 cm) diameter. Follow the instructions below to make the proper adjustment.
- 2) The U-shaped bale guide must be adjusted to its minimal width (Fig. 59).
- 3) For tubing silage bales of 48" to 56" (122 cm to 142 cm).
  - 3.1 Adjust the upper stretchers to their lowest position (the clevis is not used) (Fig. 60) and install the extension as shown (Fig. 61).
  - 3.2 Adjust the lateral stretchers to the inside position (Fig. 62).
  - 3.3 Adjust the bottom stretchers to the inside position (Fig. 63).



Figure 62

---

## OPERATION FOR ROUND BALES (cont'd)

---



Figure 63

- 4) For tubing silage bales of 56" to 66" (142 cm to 168 cm).
  - 4.1 Adjust the upper stretchers to the lower hole (Fig. 64) and install the extension as shown (A Fig. 64).
  - 4.2 Adjust the lateral stretchers to the outside position (Fig. 65).
  - 4.3 Adjust the lower stretchers to the outside position (Fig. 66).
- 5) Use turnbuckles provided (Fig. 67) to adjust lower guide according to the width of the bales (Fig. 68). It is important that the bales are centred on the machine.

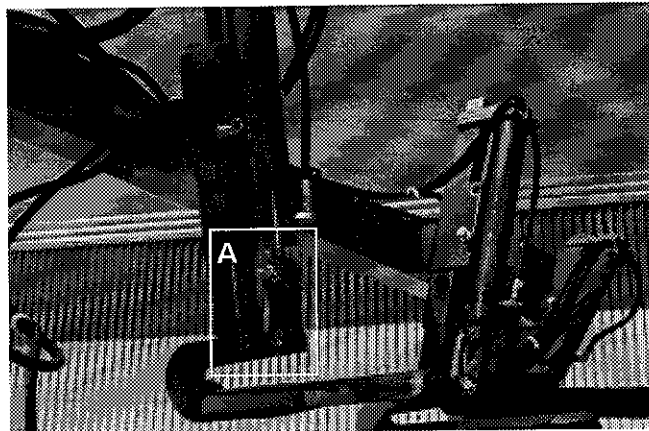

Figure 64



Figure 66



Figure 65

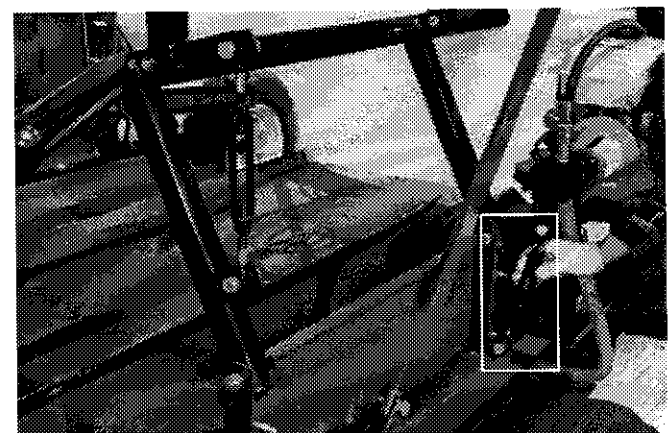

Figure 67

---

## OPERATION FOR ROUND BALES (cont'd)

---

4

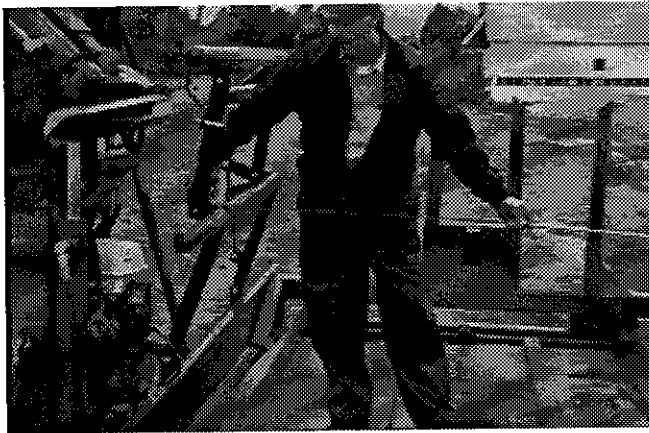

Figure 68



Figure 69



Figure 70

- 6) The upper guide is not useful for tubing of round silage bale. Use turnbuckles provided (Fig. 69) and adjust upper guide to a larger dimension to avoid it being an obstacle.
- 7) Locate the rear end of the Agripac® Lastic Tuber™ approximately 5' (152 cm) away from the point where you want to position the end of the tube. This will compensate if there is some slippage of the first couple of bales until there is enough ground friction to push the Agripac® Lastic Tuber™ forward.
- 8) The Agripac® Lastic Tuber™ can be operated with the tongue assembly on. If there is a risk of interference with the front of the tractor or with uneven ground, it is recommended to remove it (Fig. 70).
- 9) For maximum operating speed, you may set the engine to full throttle, although it is preferable to run it a speed closer to your rate of bale supply to machine. This will result in a more economical operation.



## OPERATION FOR ROUND BALES (cont'd)



Figure 71

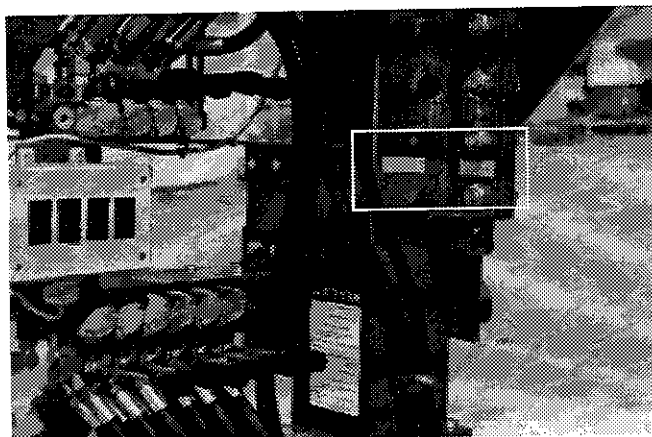

Figure 72

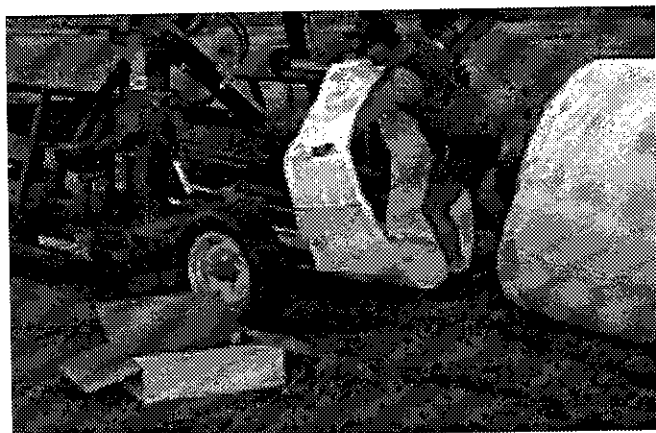

Figure 73

### OPERATION

- 1) Start engine.
- 2) Pull out the tube support plate (Fig. 71).
- 3) Adjust the height of the two lateral stretchers to the lower yellow mark (Fig. 72).
- 4) Place all the stretchers to their inward position.
- 5) Remove the tube from its box, lay it flat on the ground. Place your forearm at the center of the tube to manipulate it (Fig. 73).
- 6) Install the tube on the stretchers arms. Slide it carefully to the bottom of the stretcher arms, being careful to remove all wrinkles, since they could cause some tearing of the tube (Fig. 74). Place it so that the tube name is facing outside when it unfolds.
- 7) Open each pair of stretcher arms to apply a light tension to the tube, giving it a shape that resembles of a bale.
- 8) Return the tube support plate to its closed position. **WARNING:** It is very important that you proceed to step 7 before this one because you can cause some tearing of the tube by closing the tube support plate.

4



Figure 74

## OPERATION FOR ROUND BALES (cont'd)

4

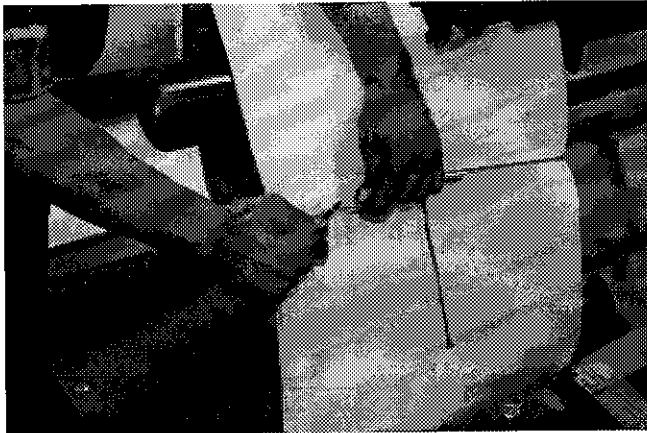

Figure 75



Figure 76



Figure 77

- 9) Again check the tube position and eliminate any wrinkles. Next, cut off all ties as shown (Fig. 75).
- 10) Now it's time to close the end of the tube. Pull out the outer ply of the plastic tube. Pull about 36" (91 cm) and close properly the tube as shown (Fig. 76 et Fig. 77).
- 11) **STRETCH THE TUBE ONLY WHEN READY TO OPERATE.** It may lose some of its capacity to retract if kept stretched for a too long period of time. If you must stop loading bales for a while, **BRING THE TUBE DOWN TO A MODERATE TENSION.**
- 12) Before loading the first bale, place the switch for pusher mode to manual mode (Fig. 78).
- 13) Load the first bale on the machine, operate the control valve manually until the bale approaches the arms and stop it there.
- 14) Stretch the tube by operating the three valves **SIMULTANEOUSLY** (Fig. 79) to obtain a **CLEARANCE OF APPROXIMATELY 2" to 3"** (5 cm to 7.6 cm) between the bale and the tube (Fig. 80). Readjust stretcher arms individually if necessary.

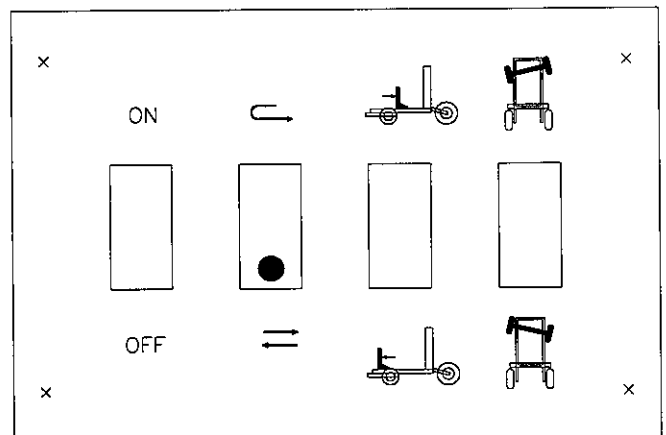

Figure 78

---

## OPERATION FOR ROUND BALES (cont'd)

---

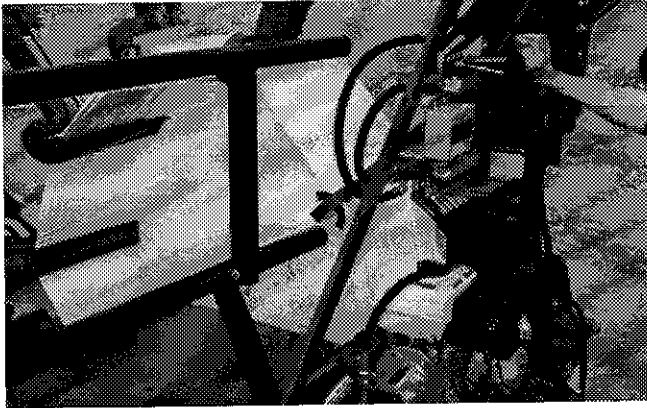

Figure 79



Figure 80



Figure 81

- 15) Adjust rear wheels in order to have a minimum amount of ground friction with the rear end of the Agripac® Lastic Tuber™ while keeping it in contact with the ground (Fig. 81).
- 16) Place the switch for pusher mode to automatic mode.
- 17) It is recommended to use a double spear on your loader to place the bales onto the Agripac® Lastic Tuber™.
- 18) After the first 4 or 5 bales, lift up lightly the rear wheels of the Agripac® Lastic Tuber™ to increase ground friction. This will ensure that the bales will be real tight against each other in the tube.
- 19) Towards the end of the tube, watch the plastic quantity on the stretcher arms. Keep at least 36" (91 cm) of plastic for 4' (122 cm) bales and a bit more for 5' (152 cm) bales in order to allow for proper closure of the tube.
- 20) To push the last bale into the tube, install the pusher extension supplied with the Agripac® Lastic Tuber™ (Fig. 82).



Figure 82

---

---

## OPERATION FOR ROUND BALES (cont'd)

---

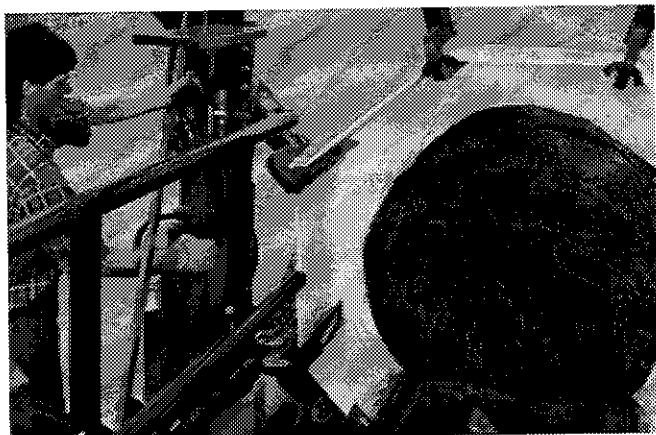

4

Figure 83

- 21) Push the bale with the pusher in manual mode in order to eject the last bale from Agripac® Lastic Tuber™.
- 22) Remove the pusher extension and store it in its receptacle on the right hand side of the Agripac® Lastic Tuber™ (Fig. 83).
- 23) Close up end of tube as previously described (Fig. 84).
- 24) Regularly inspect the tubes. If torn or punctured, repair openings with proper means.



Figure 84

---

---

# MAINTENANCE

---

- 1) Refer to the manufacturer's instructions for the engine.
- 2) Use a high quality lithium base grease containing molybdenum disulfide ( $\text{MoS}_2$ ) such as «Esso Unirex EP1 Moly», «DARINA XL-Multi Season Moly, Grade #1» from Shell or equivalent.
- 3) Wipe off all grease fittings with a clean cloth before adding grease in order to avoid injecting dirt or sand.
- 4) Repair or replace damaged grease fittings.
- 5) Lubricate stretcher arms guides every 20 hours of operation.
- 6) Lubricate all grease fittings every 20 hours of operation.
- 7) Open, clean and lubricate wheel bearings once a year.
- 8) Check oil level in hydraulic reservoir every 20 hours of operation. If necessary add good quality trans hydraulic oil such as «Trans Hydraulic Duratran» from Petro-Canada, «DONAX TD» from Shell or equivalent.
- 9) Change oil filter after the first 50 hours of operation and then every 250 hours. Use replacement filter no. K-22001, ALBERTA AG-INDUSTRIES LTD. part No. 32007.
- 10) Check all nuts and bolts once a year. If necessary use torque chart on page 50.
- 11) Check all bolts on wheels after first 5 hours of operation and then every 50 hours.
- 12) Check tire pressure every 50 hours. Adjust according to manufacturer's recommendation indicated on the tires.

5

---

---

## ***STORAGE***

---

- 1) Store the Agripac® Lastic Tuber™ in a cool, dry place.
- 2) Lower the Agripac® Lastic Tuber™ frame on wooden blocks.
- 3) Keep tires off the ground and cover them if left exposed to the sun.
- 4) Keep all piston rods in the retracted position. This will assure better protection against the elements.
- 5) Clean your Agripac® Lastic Tuber™.
- 6) Touch-up or repaint if necessary.
- 7) Lubricate all points before storage.
- 8) Drain all fuel from tank and follow engine manufacturer's storage recommendations.

# SPECIFICATIONS

Agripac® Lastic Tuber™	Model 9200
Overall length	150" (4.71 m) (without the 28" (71 cm) tongue)
Overall width	105" (267 cm) (motor in transport position)
Height	114" (289 cm) (wheels in transport position)
Round bales	48" to 66" (122 cm to 168 cm) diameter
Square bales height	37" to 72" (939 cm to 1828 cm)
Square bales width	36" to 60" (914 cm to 1524 cm)
Engine	HONDA 20 HP
Electric starting	Standard
Double hyd. pump	2 x 6.62 gal
Front hub	cap. 2500 lbs (1136 kg) 5 bolts
Rear hub	cap. 2500 lbs (1136 kg) 5 bolts
Front rim	10" x 6" - 5 bolts
Rear rim	15" x 6" - 5 bolts
Front tires	20.5" x 8" x 10" - 4 plys (with tube)
Rear tires	7.00 - 15LT Workhorse
Oil tank capacity	11.5 gal US (43.50 liters)
Hyd. steering adjustment	Standard
Working lights	Standard
Road lights	Standard
Motorized moving kit	Option
Hitch weight	2740 lbs (1245 kg) app.
Total weight	6340 lbs (2881 kg) app.

Design and specifications subject to change without notice.

## PLASTIC TUBES TO USE ACCORDING TO BALES DIMENSIONS

Round bales	For bales 48" to 56" (1.22 to 1.42 m) diameter	73½" (1.87 m) lay flat
Round bales	For bales 56" to 66" (1.42 to 1.68 m) diameter	86" (2.18 m) lay flat
<b>Square bales</b>	<b>Bales height + Bales width = Half-perimeter</b>	
Square bales	For half-perimeter 88" to 104" (2.24 to 2.64 m)	86" (2.18 m) lay flat
Square bales	For half-perimeter 102" to 120" (2.59 to 3.05 m)	100" (2.54 m) lay flat
Square bales	For half-perimeter 115" to 136" (2.92 to 3.54 m)	113" (2.87 m) lay flat

# DETAIL OF ARCH 9200

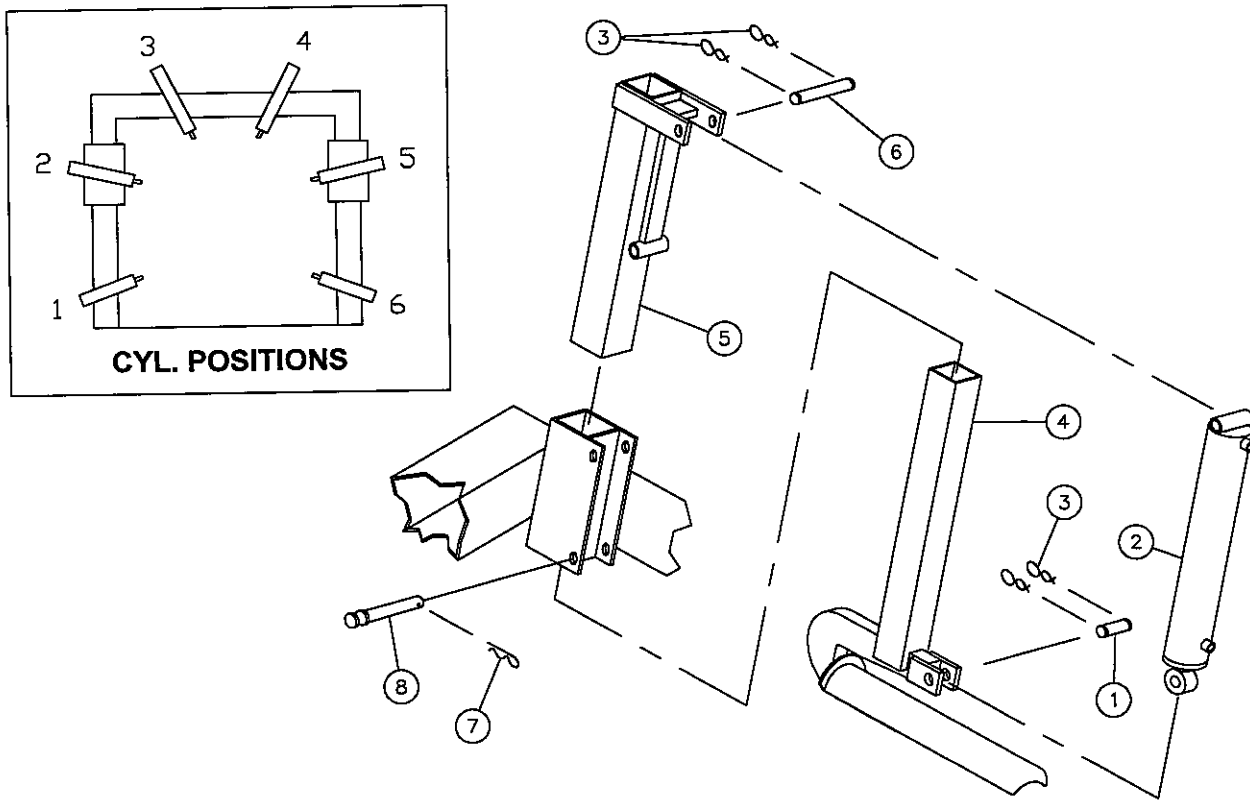

REF.	PART #	DESCRIPTION	QTY CYL POSITION #					
			1	2	3	4	5	6
1	Std.	Pin 1" x 3" lg .....	1	1	1	1	1	1
2	30H10	Cylinder .....	1	-	-	-	-	1
2	30H23	Cylinder .....	-	1	1	1	1	-
3	Std.	Hair pin 1/8" .....	4	4	4	4	4	4
4	110-04051	Stretcher arm .....	-	1	1	1	1	-
4	32156	Stretcher arm .....	1	-	-	-	-	1
5	32157	Stretcher arm guide .....	1	-	-	-	-	1
5	110-04041	Stretcher arm guide .....	-	1	1	1	1	-
6	32160	Pin 1" x 5" lg .....	1	1	1	1	1	1
7	Std.	Hitch pin clip 3/16" .....	1	1	1	1	1	1
8	32161	Pin 1" x 5 1/4" lg .....	1	1	1	1	1	1

**8**



# ARCH CYLINDER 9200

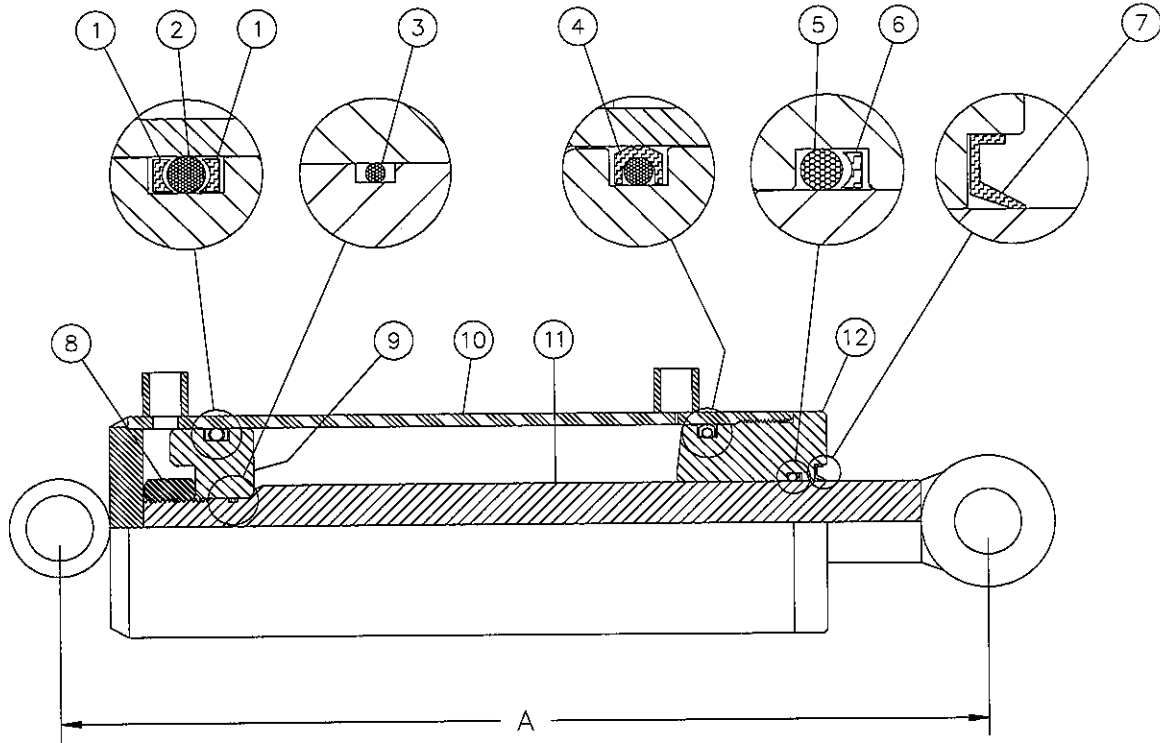

MODEL	LENGTH A
30H10	16 3/4"
30H23	29 3/4"

REF.	PART#	DESCRIPTION	QTY CYLINDER #	
			30H10	30H23
1	BU-334	Back-up ring 3/16" x 2 5/8" x 3" .....	2	2
2	OR-334	O-ring 3/16" x 2 5/8" x 3" .....	2	2
3	OR-018	O-ring 1/16" x 3/4" x 7/8" .....	1	1
4	PSP-334	O-ring "heavy duty" 3/16" x 2 5/8" x 3" .....	1	1
5	OR-218	O-ring 1/8" x 1 1/4" x 1 1/2" .....	1	1
6	BU-218	Back-up ring 1/8" x 1 1/4" x 1 1/2" .....	1	1
7	CR12330	Wiper 1/8" x 1 1/4" x 1 1/2" .....	1	1
8	Std.	Nut 7/8" NF .....	1	1
9	D-6000	Piston 3" dia. ....	1	1
10	D-6168	Cylinder body 3" for 30H10 .....	1	-
10	110-03541	Cylinder body 3" for 30H23 .....	-	1
11	D-6099	Piston rod 1 1/4" for 30H10 .....	1	-
11	110-03531	Piston rod 1 1/4" for 30H23 .....	-	1
12	D-6093	Head 3" dia. ....	1	1
NI*	32204	Repair kit for cylinder 3" (includes # 1, 2, 3, 4, 5, 6, & 7) .....	1	1

\*NI= NOT ILLUSTRATED

8

# LATERAL CYLINDER # 25E35

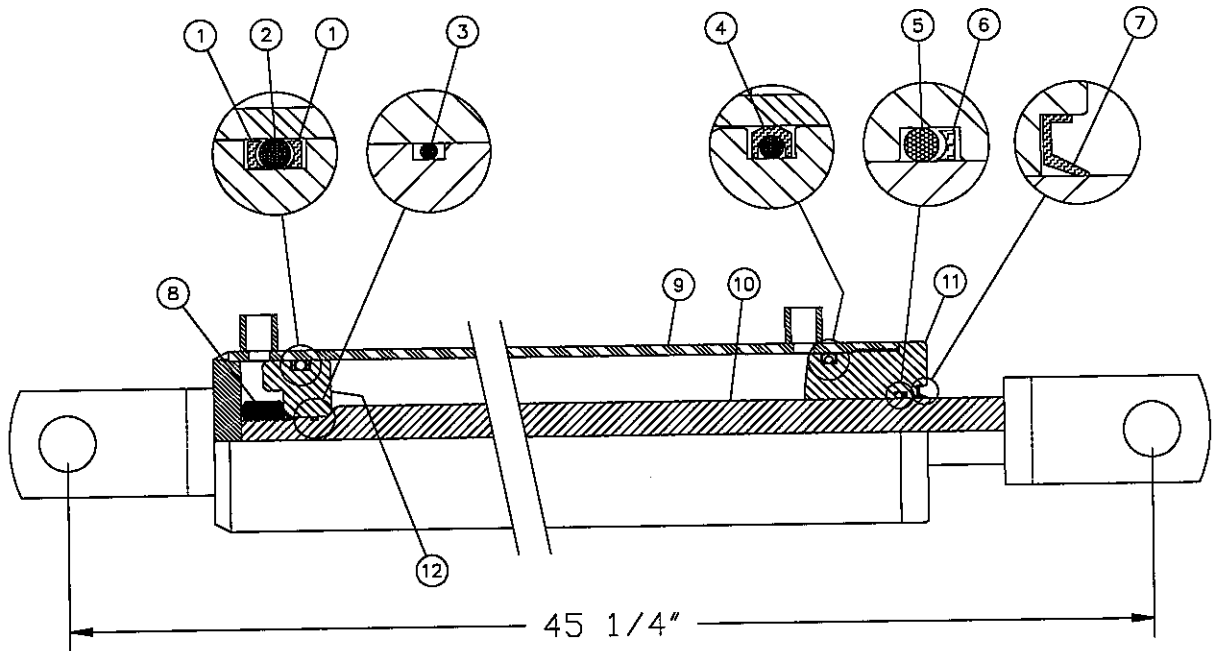

**8**

REF.	PART #	DESCRIPTION	QTY
1	BU-330	Back-up 3/16" x 2 1/8" x 2 1/2" .....	2
2	OR-330	O-ring 3/16" x 2 1/8" x 2 1/2" .....	1
3	OR-018	O-ring 1/16" x 3/4" x 7/8" .....	1
4	PSP-330	O-ring "heavy duty" 3/16" x 2 1/8" x 2 1/2" .....	1
5	OR-224	O-ring 1/8" x 1 3/4" x 2" .....	1
6	BU-224	Back-up 1/8" x 1 3/4" x 2" .....	1
7	CR17240	Wiper .....	1
8	338-48000	Nut 7/8" - 14 .....	1
9	110-03561	Cylinder body 2 1/2" dia. for 25E35 .....	1
10	110-03551	Piston rod 1 3/4" dia. for 25E35 .....	1
11	150-01161	Head 2 1/2" dia. ....	1
12	150-01151	Piston 2 1/2" dia. ....	1
NI*	32244	Repair kit for cylinder (includes # 1 à 7) .....	1

\*NI= NOT ILLUSTRATED

# CYLINDER 20TR24

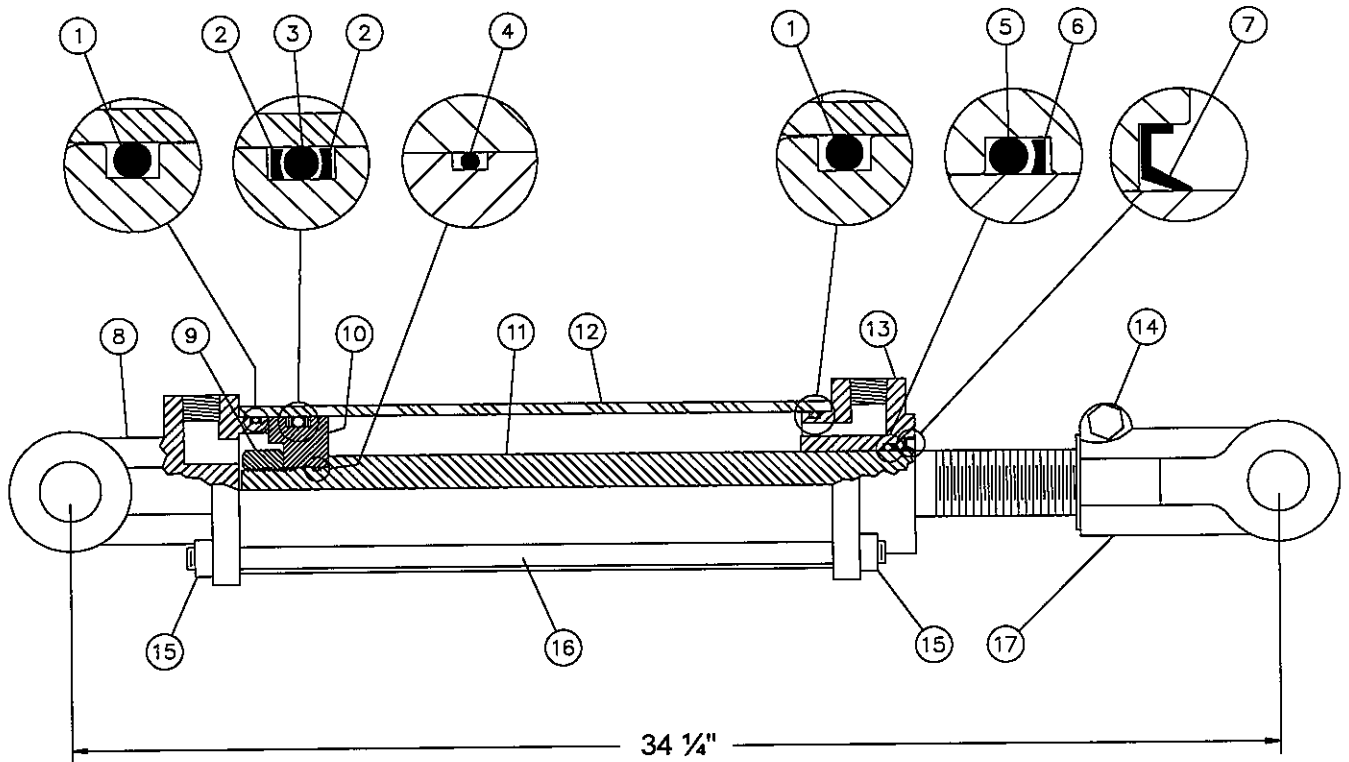

REF.	PART #	DESCRIPTION	QTY
1	See RK20TR	O-ring 3/32" x 1 13/16" x 2" .....	2
2	See RK20TR	Back-up 2" o.d. x 1/8" ø .....	2
3	See RK20TR	O-ring 3/16" x 1 5/8" x 2" .....	1
4	See RK20TR	O-ring 1/16" x 5/8" x 3/4" .....	1
5	See RK20TR	O-ring 1/8" x 1 1/8" x 1 3/8" .....	1
6	See RK20TR	Back-up 1 3/8" o.d. x 1/8" ø .....	1
7	See RK20TR	Wiper 1 1/8" i.d. x 1 5/8" o.d. ....	1
8	492400	Yoke (for 2" tube) .....	1
9	Std.	Nut 3/4" NF .....	1
10	4924-30	Piston 2" ø .....	1
11	491980-24	Piston rod 1 1/8" .....	1
12	491608-24	Cylinder body 2" ø .....	1
13	492420	Head (for 2" tube) .....	1
14	Std.	Bolt 3/8" NC x 2 1/4" + nut .....	1
15	Std.	Nut 3/8" NC .....	8
16	Std.	Threaded rod 3/8" NC x 28" lg .....	4
17	458599	Yoke (for 1 1/8" rod) .....	1
NI*	8183	Pin 1" ø + cotter pin .....	2
NI*	RK20TR	Repair kit for cylinder 2" (includes # 1, 2, 3, 4, 5, 6, & 7) .....	1

8

\*NI = NOT ILLUSTRATED

# CYLINDER 25TR04

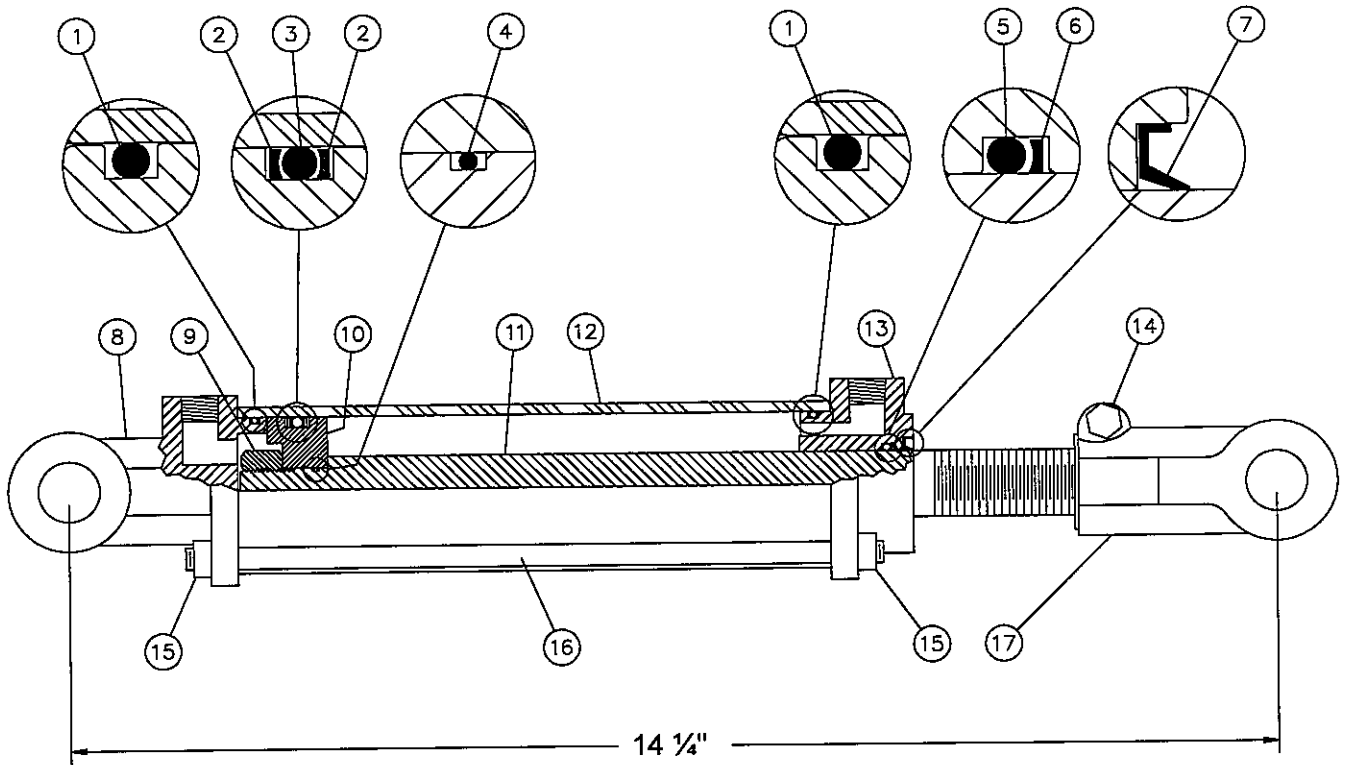

REF.	PART #	DESCRIPTION	QTY
1	See RK25TR	O-ring 1/8" x 2 1/4" x 2 1/2" .....	2
2	See RK25TR	Back-up 2 1/2" o.d. x 1/2" ø .....	2
3	See RK25TR	O-ring 3/16" x 2 1/8" x 2 1/2" .....	1
4	See RK25TR	O-ring 1/16" x 5/8" x 3/4" .....	1
5	See RK25TR	O-ring 1/8" x 1 1/8" x 1 3/8" .....	1
6	See RK25TR	Back-up 1 3/8" o.d. x 1/8" ø .....	1
7	See RK25TR	Wiper 1 1/8" i.d. x 1 5/8" o.d. ....	1
8	492401	Yoke (for 2 1/2" tube) .....	1
9	Std.	Nut 3/4" NF .....	1
10	4924-31	Piston 2 1/2" ø .....	1
11	491980-04	Piston rod 1 1/8" .....	1
12	491668-04	Cylinder body 2 1/2" ø .....	1
13	492421	Head (for 2 1/2" tube) .....	1
14	Std.	Bolt 3/8" NC x 2 1/4" + nut .....	1
15	Std.	Nut 3/8" NC .....	8
16	Std.	Threaded rod 3/8" NC x 8" lg .....	4
17	458599	Yoke (for 1 1/8" rod) .....	1
NI*	8183	Pin 1" ø + cotter pin .....	2
NI*	RK25TR	Repair kit for cylinder 2 1/2" (includes # 1, 2, 3, 4, 5, 6, & 7) .....	1

\*NI = NOT ILLUSTRATED

8

# CYLINDER 30TR04

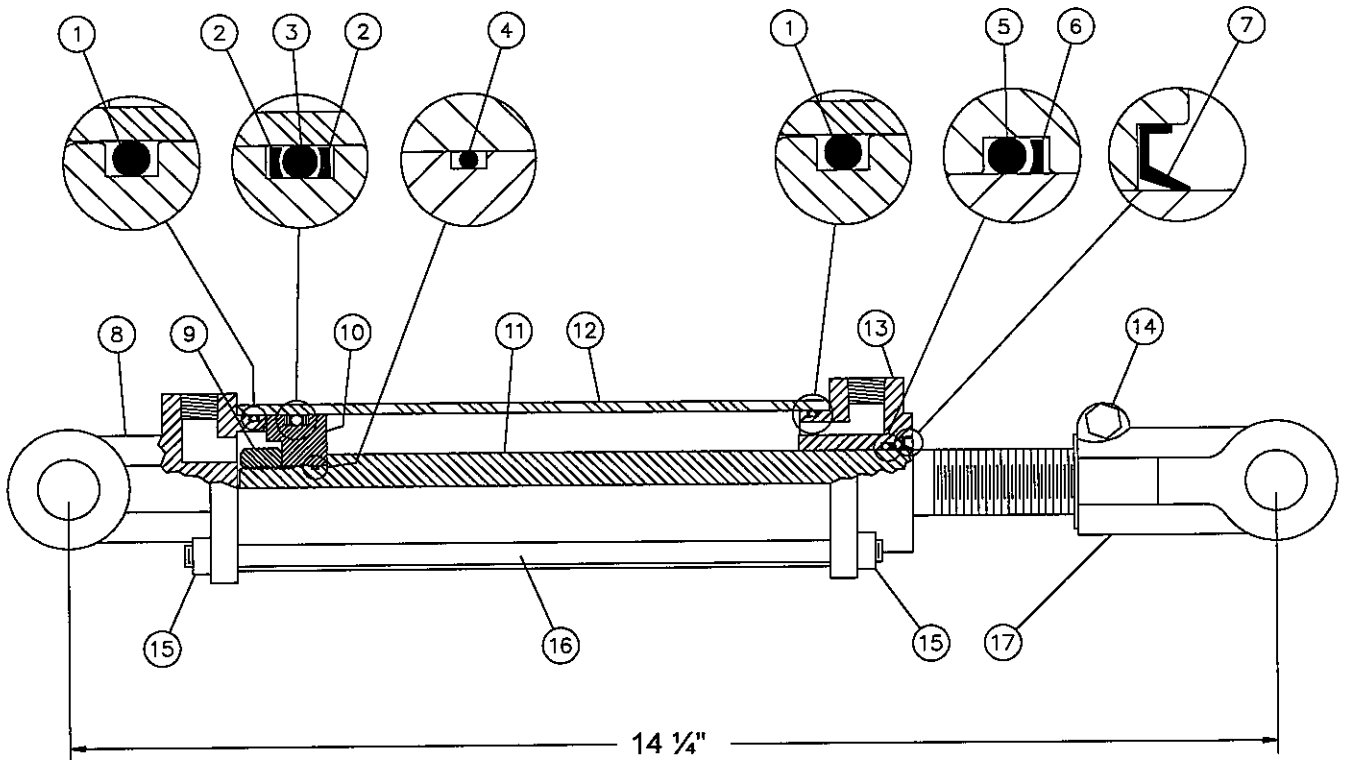

REF.	PART #	DESCRIPTION	QTY
1	See RK30TR	O-ring 1/8" x 2 3/4" x 3" .....	2
2	See RK30TR	Back-up 3" o.d. x 1/8" ø .....	2
3	See RK30TR	O-ring 3/16" x 2 5/8" x 3" .....	1
4	See RK30TR	O-ring 1/16" x 7/8" x 1" .....	1
5	See RK30TR	O-ring 1/8" x 1 1/4" x 1 1/2" .....	1
6	See RK30TR	Back-up 1 1/2" o.d. x 1/8" ø .....	1
7	See RK30TR	Wiper 1 1/4" i.d. x 1 3/4" o.d. ....	1
8	492402	Yoke (for 3" tube) .....	1
9	Std.	Nut 3/4" NF .....	1
10	4924-32	Piston 3" ø .....	1
11	492088-4	Piston rod 1 1/4" .....	1
12	491738-4	Cylinder body 3" ø .....	1
13	492440	Head (for 3" tube) .....	1
14	Std.	Bolt 3/8" NC x 2 1/4" + nut .....	1
15	Std.	Nut 3/8" NC .....	8
16	Std.	Threaded rod 3/8" NC x 8" lg .....	4
17	458600	Yoke (for 1 1/4" rod) .....	1
NI*	8183	Pin 1" ø + cotter pin .....	2
NI*	RK30TR	Repair kit for cylinder 3" (includes # 1, 2, 3, 4, 5, 6, & 7) .....	1

8

\*NI = NOT ILLUSTRATED

# PUSHER HYDRAULIC MOTOR #32361

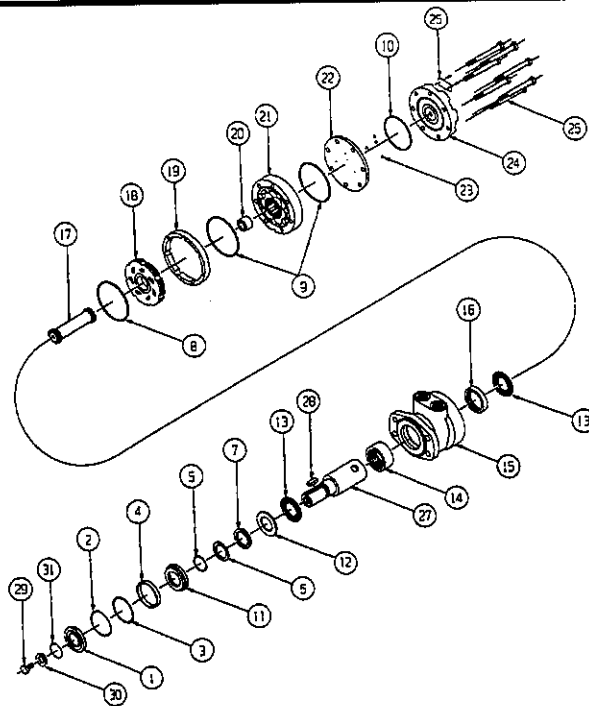

REF.	PART #	DESCRIPTION	QTY
1	See PE444002	Dust seal .....	1
2	See PE444002	Split wire ring .....	1
3	See PE444002	Metal backup shim .....	1
4	See PE444002	High pressure seal .....	1
5	See PE444002	Metal backup shim .....	1
6	See PE444002	Teflon backup seal .....	1
7	See PE444002	Shaft seal .....	1
8	See PE444002	Housing seal .....	1
9	See PE444002	Body seal .....	2
10	See PE444002	Endcover seal .....	1
11	See PE444003	Seal carrier .....	1
12	See PE444003	Thrust washer .....	1
13	PE018059	Thrust bearing .....	2
14	PE018003	Front housing bearing .....	1
15	PE130823	Housing .....	1
16	PE018002	Rear housing bearing .....	1
17	PE014008	Drive link .....	1
18	PE015007	Manifold .....	1
19	PE018041	Manifold boot .....	1
20	PE018076	Drive link spacer kit .....	1
21	PE357003	Rotor assembly .....	1
22	See PE012001	Balance plate .....	1
23	See PE012001	Steel balls .....	4
24	PE016001	Endcover .....	1
26	PE445026	Assembly bolt .....	7
27	PE011201	Shaft .....	1
28	PE449100	Shaft key .....	1
NI*	PE444001	Repair kit (includes # 1, 2, 3, 4, 5, 6, 7, 8, 9, 10, 11, 12) .....	1
NI*	PE444002	Repair kit (includes # 1, 2, 3, 4, 5, 6, 7, 8, 9 & 10) (see PE444001) .....	2
NI*	PE444003	Repair kit (includes # 11 & 12) (see PE444001) .....	2
NI*	PE012001	Balance plate kit (includes # 22 & 23) .....	2

\*NI = NOT ILLUSTRATED

# HYDRAULIC MOTOR # DH 400

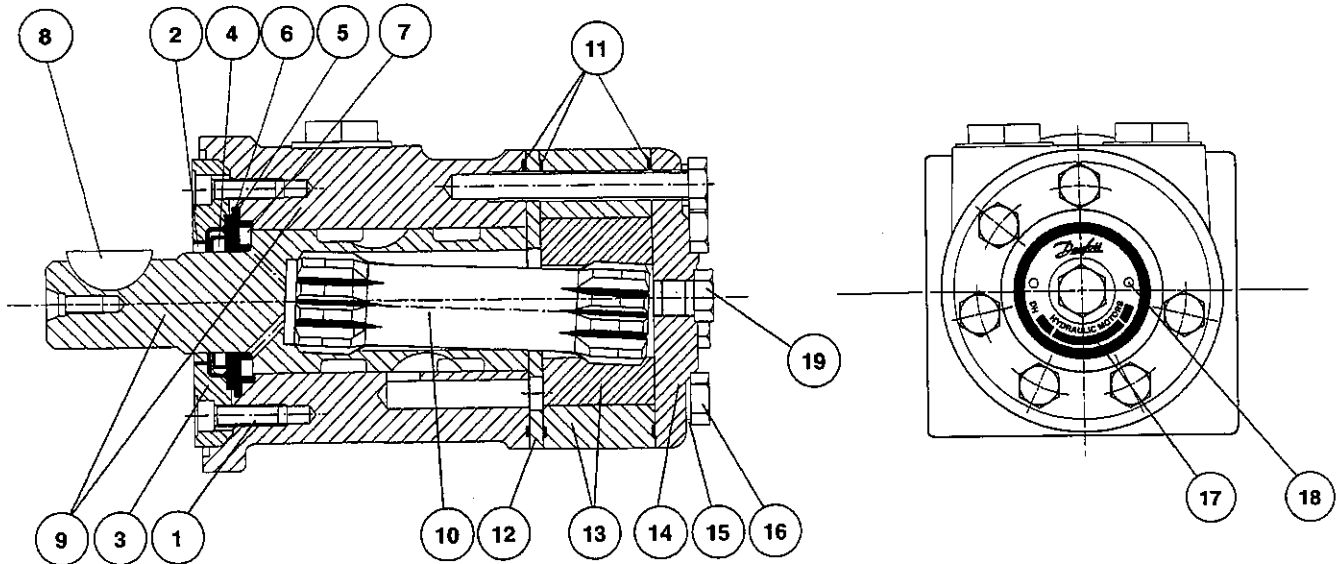

REF.	CODE #	DESCRIPTION	QTY
			DH 400
1	681X1961	Screw M5 x 16mm .....	6
2	151-1313	Dust seal ring .....	1
3	151-1827	Spigot flange .....	1
4	633B3385	Shaft seal BAKDH ring .....	1
5	633B1333	O-ring .....	1
6	151-1608	Bearing race .....	1
7	151-1458	Axial needle bearing .....	1
8	682L9054	Woodruff key .....	1
9	-----	Housing and output shaft .....	not sold
10	151-2651	Cardan shaft .....	1
11	633B1173	O-ring .....	3
12	151-1713	Distributor plate .....	1
13	151-1187	Gear wheel set .....	1
14	151-2641	End cover .....	1
15	684X2481	Washer .....	6
16	681X0188	Screw M8 x 1.25mm Din 931 x 80mm lg .....	6
17	151A0415	Name plate .....	1
18	681Z1011	Drive screw .....	2
19	631X2013	Drain plug 7/16"-20 UNF .....	1
NI*	151-1273	Set of seals .....	1

\*NI = NOT ILLUSTRATED

# CONTROL VALVE

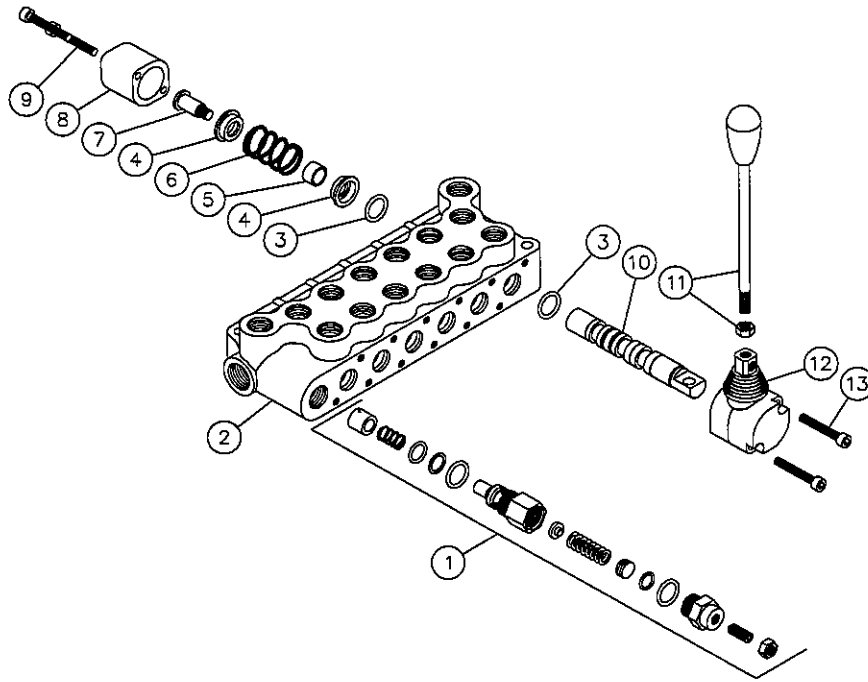

8

REF.	PART #	DESCRIPTION	QTY				
			640-10003	640-20001	640-30001	640-40001	640-60001
		Number of spool .....	1	2	3	4	6
1	649-00000	Relief valve .....	1	1	1	1	1
2	649-00011	Valve housing 6 spool .....	-	-	-	-	1
2	649-00018	Valve housing 4 spool .....	-	-	-	1	-
2	649-00019	Valve housing 3 spool .....	-	-	1	-	-
2	649-00020	Valve housing 2 spool .....	-	1	-	-	-
2	649-00021	Valve housing 1 spool .....	1	-	-	-	-
3	649-00002	O-ring .....	2	4	6	8	12
4	649-00003	Spring retainer .....	2	4	6	8	12
5	649-00004	Ring .....	1	2	3	4	6
6	649-00005	Spring .....	1	2	3	4	6
7	649-00006	Bolt .....	1	2	3	4	6
8	649-00007	Endcap .....	1	2	3	4	6
9	331-12840	Bolt M6 - 1.0 x 40 mm lg .....	2	4	6	8	12
10	649-00008	Valve spool .....	1	2	3	4	6
11	649-00009	Lever .....	1	2	3	4	6
12	649-00010	Lever cap .....	1	2	3	4	6
13	331-12845	Bolt M6 - 1.0 x 45 mm lg .....	2	4	6	8	12



# HYDRAULIC DOUBLE PUMP #MHP-22

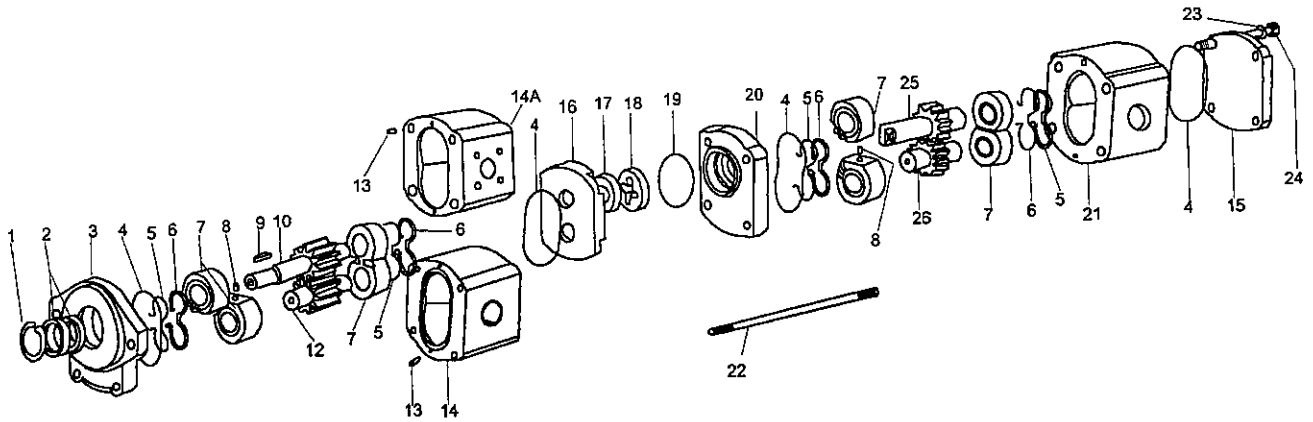

REF.	CODE #	DESCRIPTION	QTY
1	SN-2	Circlip .....	1
2	SS-2	Shaft seal .....	2
3	F2-2	Mounting flange .....	1
4	BO-2	Body o-ring .....	4
5	BS-2	Bush lobe seal .....	4
6	BR-2	Backing ring .....	4
7	BV-2	Bush (matching pair) .....	4
8	PB-2	Pin (bush) .....	4
9	KE-2	Square key .....	1
10	DSXX-048F	Drive shaft parallel (front) .....	1
11	WK-2	Woodruff key .....	1
12	DG2-048	Driven gear .....	1
13	PH-2	Pin (body) .....	1
14	H2-048	Body (sae port) .....	1
14a	H2-0485	Body (split flange) .....	0
15	C-2	End cover .....	1
16	MC-2	Middle cover .....	1
17	SC-2	Seal (middle cover) .....	1
18	DC-2	Coupling .....	1
19	FO-2	O-ring (middle flange) .....	1
20	MF-2	Middle flange .....	1
21	H2-048	Body .....	1
22	ST-048	Stud .....	2
23	LW-2	Washer .....	2
24	N-2	Nut .....	2
25	DS2-048R	Drive shaft (rear) .....	1
26	DG2-048	Driven gear (rear) .....	1

8

# ENGINE ASSEMBLY WITH PUMP

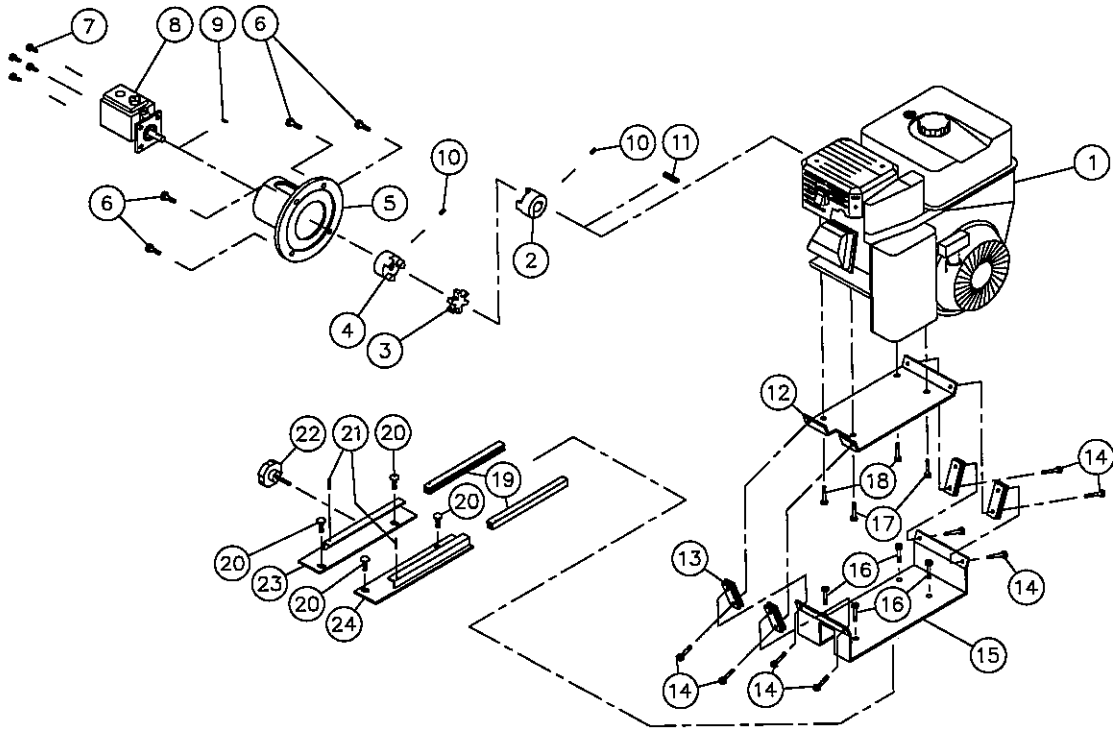

8

REF.	PART #	DESCRIPTION	QTY
			9200
1	32258	Engine HONDA 20HP with electric starter .....	1
2	32133	Flexible coupling 1" ø .....	1
3	32134	Flexible coupling .....	1
4	32259	Flexible coupling 5/8" ø .....	1
5	32260	Mounting flange .....	1
6	Std.	Bolt 3/8" NC x 1" lg + lock washer .....	4
7	Std.	Bolt 3/8" NC x 1 1/2" lg + lock washer .....	2
8	MHP-22	Double pump .....	1
9	Std.	Woodruff key 1/8" .....	1
10	Std.	Socket set screw 5/16" NC x 1/2" .....	2
11	Std.	Square key 1/4" x 1 1/2" lg .....	1
12	32194	Upper motor mounting plate .....	1
13	32195	Anti-vibration supports .....	8
14	Std.	Bolt 5/16" NC x 1" lg + nylon locknut & flat washer .....	8
15	32196	Lower motor mounting plate .....	1
16	Std.	Bolt 3/8" NC x 1" lg + nylon locknut .....	4
17	Std.	Bolt 3/8" NC x 1 3/4" lg + nylon locknut .....	2
18	Std.	Bolt 3/8" NC x 1 3/4" lg + nylon locknut & flat washer .....	2
19	190-00202	Sliding engine mount .....	2
20	Std.	Carriage bolt 3/8" NC x 1" lg + nylon locknut .....	4
21	Std.	Roll pin 1/8" x 1" lg .....	2
22	110-00591	Slide handle .....	1
23	110-00582	Left fixation for slide .....	1
24	110-00572	Right fixation for slide .....	1

# HUB H2500

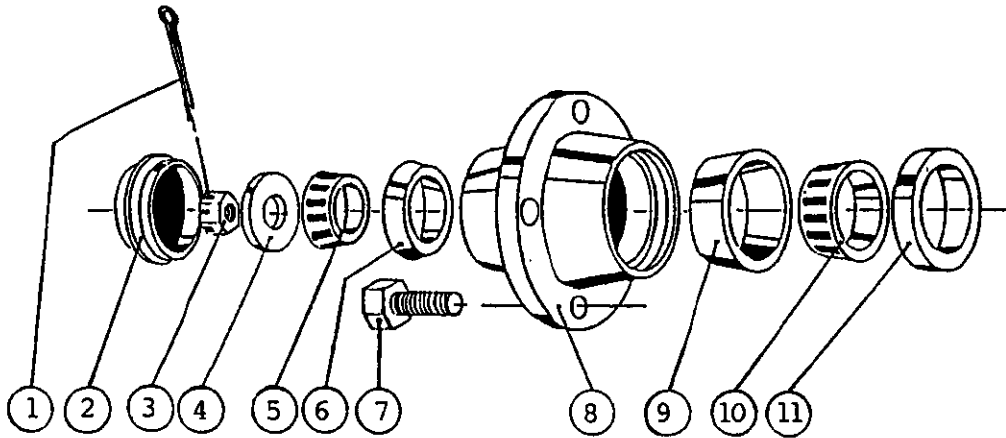

REF.	PART #	DESCRIPTION	QTY
1	Std.	Cotter pin 5/32" x 1 1/2" .....	1
2	53019	Dust cap D-1000 1.973" $\varnothing$ .....	1
3	51529	Castle nut 1" NF x 9/16" thick .....	1
4	Std.	Flat washer 1" .....	1
5	53058	Roller bearing Timken: cone no. L44649 .....	1
6	53023	Roller bearing Timken: cup no. L44610 .....	1
7	53024	Rim screw 1/2" .....	5
8	53059	Hub only H2500 .....	1
9	51415	Roller bearing Timken: cup no. LM48510 .....	1
10	51416	Roller bearing Timken: cone no. LM48548 .....	1
11	51535	Oil seal no. CR17415 .....	1

8

# HYDRAULIC SYSTEM

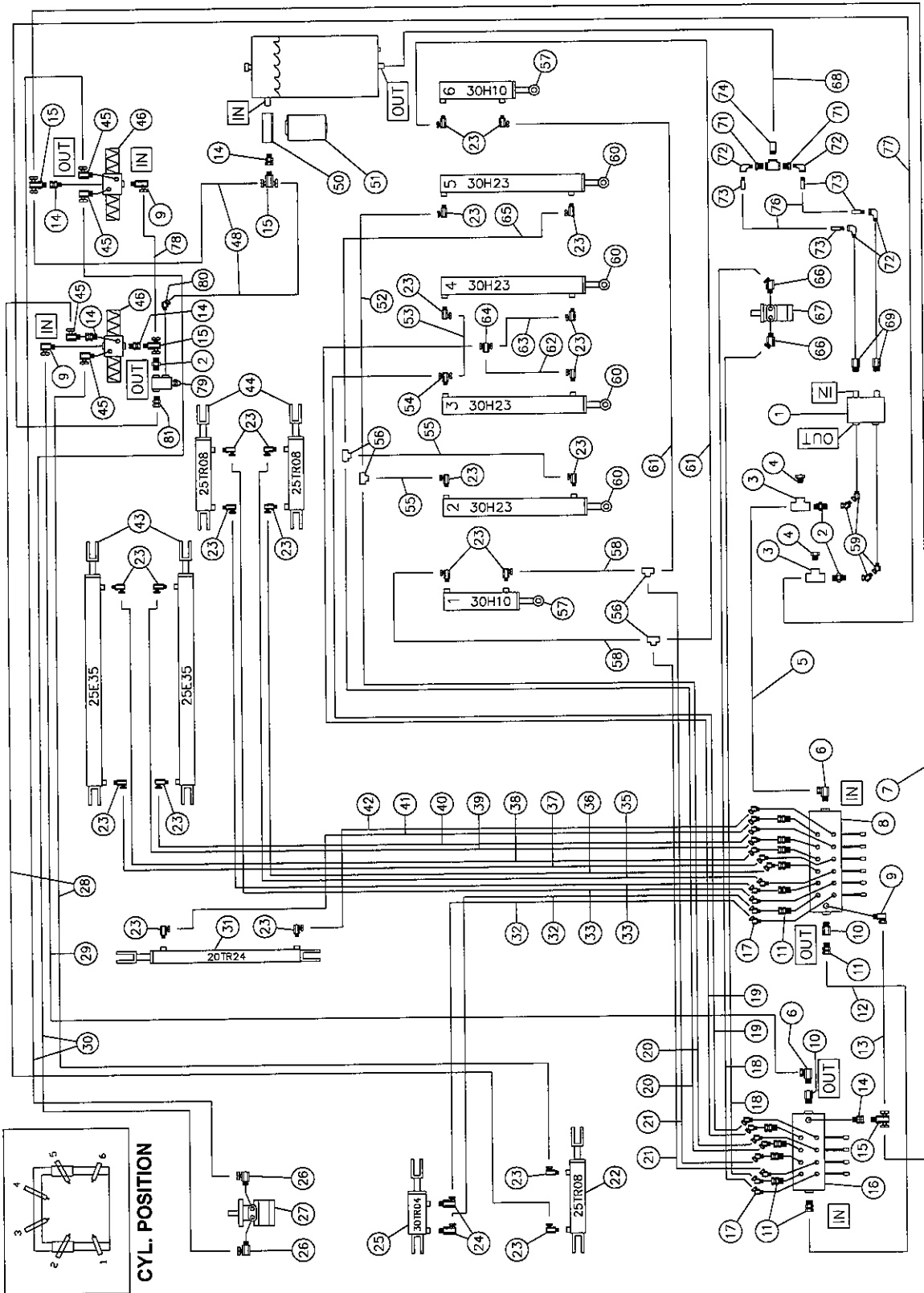

# HYDRAULIC SYSTEM (cont'd)

**WARNING:** This drawing shown an Agripac® Lastic Tuber™ 9200 equipped with all the options availables. An Agripac® Lastic Tuber™ without option use only a 6 spool valve and one selenoid valve. If there is one or more option installed, a valve with 1 up to 4 spool must be added.

- BASE 9200 = Agripac® Lastic Tuber™ without option
- OPT. 6405 = Round bales option
- OPT. 6415 = Hydraulic U-shaped guide option
- OPT. 6425 = Motorized moving kit option

REF.	PART #	DESCRIPTION	QTY			
			BASE 9200	OPT. P-6405	OPT. P-6415	OPT. P-6425
1	MHP-22	Double pump .....	1	-	-	-
2	Std.	Straight female pipe to male pipe ½" C3069 x 8 .....	4	-	-	-
3	Std.	"T" ½" C3709 x 8 .....	2	-	-	-
4	Std.	Plug ½" C3159 x 8 .....	1	-	-	-
5	190-01731	Hose 1/2" x 48" lg + 2 fittings 8U108 .....	1	-	-	-
6	Std.	Fitting 90° 9515 x 10 x 8 .....	2	-	-	-
7	190-00841	Hose 1/2" x 170" lg + 2 fittings 8U108 .....	1	-	-	-
8	32238	6 spool control valve .....	1	-	-	-
9	Std.	Fitting 90° 9515 x 8 x 8 .....	2	-	-	-
10	Std.	Fitting (power beyond) .....	2	-	-	-
11	Std.	Fitting 9315 x 10 x 8 .....	2	-	-	-
12	190-00831	Hose 1/2" x 20 1/2" lg + 2 fittings 8U108 .....	1	-	-	-
13	190-01111	Hose 1/2" x 33" lg + 2 fittings 8U108 .....	1	-	-	-
14	Std.	Fitting 9315 x 8 x 8 .....	3	-	-	-
15	Std.	"T" 15855 x 8 x 8 x 8 .....	2	-	-	-
16	32239	1 spool control valve .....	-	-	1	1
16	32240	2 spool control valve .....	-	1	-	-
16	32241	3 spool control valve .....	-	-	-	-
16	32242	4 spool control valve .....	-	-	-	-
17	Std.	Fitting 45° 9355 x 6 x 6 .....	12	4	2	2
18	190-01131	Hose 3/8" x 105" lg + 2 fittings 6U106 .....	-	-	-	2
19	190-00931	Hose 3/8" x 76" lg + 2 fittings 6U106 .....	-	2	-	-
20	190-00891	Hose 3/8" x 44" lg + 2 fittings 6U106 .....	2	-	-	-
21	190-00971	Hose 3/8" x 14" lg + 2 fittings 6U106 .....	-	2	-	-
22	25TR08	Steering cylinder 2 1/2" x 8" .....	1	-	-	-
23	Std.	Fitting 90° 9405 x 6 x 6 .....	14	7	2	-
24	Std.	Fitting 90° 9405 x 6 x 8 .....	2	-	-	-
25	30TR04	Cric cylinder 3" x 4" .....	1	-	-	-
26	Std.	Fitting 90° 9515 x 10 x 8 .....	2	-	-	-
27	32361	Pusher motor (RE26080600) .....	1	-	-	-
28	190-00881	Hose 3/8" x 216" lg + 2 fittings 6U106 .....	2	-	-	-
29	190-00851	Hose 1/2" x 163" lg + 2 fittings 8U108 .....	1	-	-	-
30	190-01681	Hose 1/2" x 184" lg + 2 fittings 8U108 .....	2	-	-	-
31	20TR24	U-shaped guide cylinder 2" x 24" .....	-	-	1	-
32	190-01041	Hose 3/8" x 191" lg + 2 fittings 6U106 .....	2	-	-	-
33	190-01021	Hose 3/8" x 167" lg + 2 fittings 6U106 .....	2	-	-	-
35	190-01001	Hose 3/8" x 45" lg + 2 fittings 6U106 .....	1	-	-	-

# HYDRAULIC SYSTEM (cont'd)

REF.	PART #	DESCRIPTION	QTY			
			BASE 9200	OPT. P-6405	OPT. P-6415	OPT. P-6425
36	190-01011	Hose 3/8" x 34 1/2" lg + 2 fittings 6U106 .....	1	-	-	-
37	190-01071	Hose 3/8" x 158" lg + 2 fittings 6U106 .....	1	-	-	-
38	190-01081	Hose 3/8" x 170" lg + 2 fittings 6U106 .....	1	-	-	-
39	190-01051	Hose 3/8" x 40" lg + 2 fittings 6U106 .....	1	-	-	-
40	190-01061	Hose 3/8" x 42" lg + 2 fittings 6U106 .....	1	-	-	-
41	190-01101	Hose 3/8" x 101" lg + 2 fittings 6U106 .....	-	-	1	-
42	190-01091	Hose 3/8" x 70" lg + 2 fittings 6U106 .....	-	-	1	-
43	25E35	Lateral cylinder 2 1/2" x 35" stroke .....	2	-	-	-
44	25TR08	Rear wheels cylinder 2 1/2" x 8" stroke .....	2	-	-	-
45	Std.	Fitting 90° 9515 x 8 x 6 .....	4	-	-	-
46	18019	Selenoid valve .....	2	-	-	-
48	190-01701	Hose 1/2" x 33" lg + 2 fittings 8U108 .....	2	-	-	-
49	Std.	"T" 1" C3709 x 16 .....	1	-	-	-
50	32031	Hydraulic oil filter adaptor .....	1	-	-	-
51	32007	Paper filter .....	1	-	-	-
52	190-00911	Hose 3/8" x 108" lg + 2 fittings 6U106 .....	1	-	-	-
53	190-00951	Hose 3/8" x 73" lg + 2 fittings 6U106 .....	-	1	-	-
54	Std.	"T" 15855 x 6 x 6 x 6 .....	-	1	-	-
55	190-00901	Hose 3/8" x 66" lg + 2 fittings 6U106 .....	2	-	-	-
56	Std.	"T" C3709 x 6 .....	2	2	-	-
57	30H10	Stretcher arm cylinder 1 & 6 3" x 10" stroke .....	-	2	-	-
58	190-00991	Hose 3/8" x 71" lg + 2 fittings 6U106 .....	-	2	-	-
59	Std.	Fitting 45° 9365 x 10 x 8 .....	2	-	-	-
60	30H23	Stretcher arm cylinder 2,3,4 & 5 3" x 23" stroke .....	2	2	-	-
61	190-00981	Hose 3/8" x 215" lg + 2 fittings 6U106 .....	-	2	-	-
62	190-00961	Hose 3/8" x 19 1/2" lg + 2 fittings 6U106 .....	-	1	-	-
63	190-00941	Hose 3/8" x 93" lg + 2 fittings 6U106 .....	-	1	-	-
64	Std.	"T" 15856 x 6 x 6 x 6 .....	-	1	-	-
65	190-00921	Hose 3/8" x 115" lg + 2 fittings 6U106 .....	1	-	-	-
66	Std.	Fitting 45° 9355 x 6 x 8 .....	-	-	-	2
67	MG181313	Traction motor .....	-	-	-	1
68	190-01121	Low pressure hose 1" x 93" lg .....	1	-	-	-
69	Std.	Fitting "straight" 9515 x 12 x 12 .....	2	-	-	-
70	Std.	Fitting "straight" 9315 x 8 x 6 .....	12	4	2	2
71	Std.	Adaptor 1" to 3/4" C3109 x 16 x 12 .....	3	-	-	-
72	Std.	Fitting 90° male-female C3409 .....	4	-	-	-
73	Std.	Hose adaptor 3/4" 1 S225 .....	4	-	-	-
74	Std.	Hose adaptor 1" 1 S215 .....	1	-	-	-
75	190-01721	Boyau 1/2" x 197" lg + 2 fitting 8U108 .....	1	-	-	-
76	190-01711	Hose "low pressure" 33" lg .....	2	-	-	-
77	190-01721	Hose 1/2" x 197" lg + 2 fittings 8U108 .....	1	-	-	-
78	190-01691	Hose 1/2" x 8 1/2" lg + 2 fittings 8U108 .....	1	-	-	-
79	18020	Pressure control valve 1/2" .....	1	-	-	-
80	Std.	Fitting 45° 9355 8 x 8 .....	1	-	-	-
81	Std.	Fitting "straight" 9205 8 x 8 .....	1	-	-	-

# ELECTRIC SYSTEM

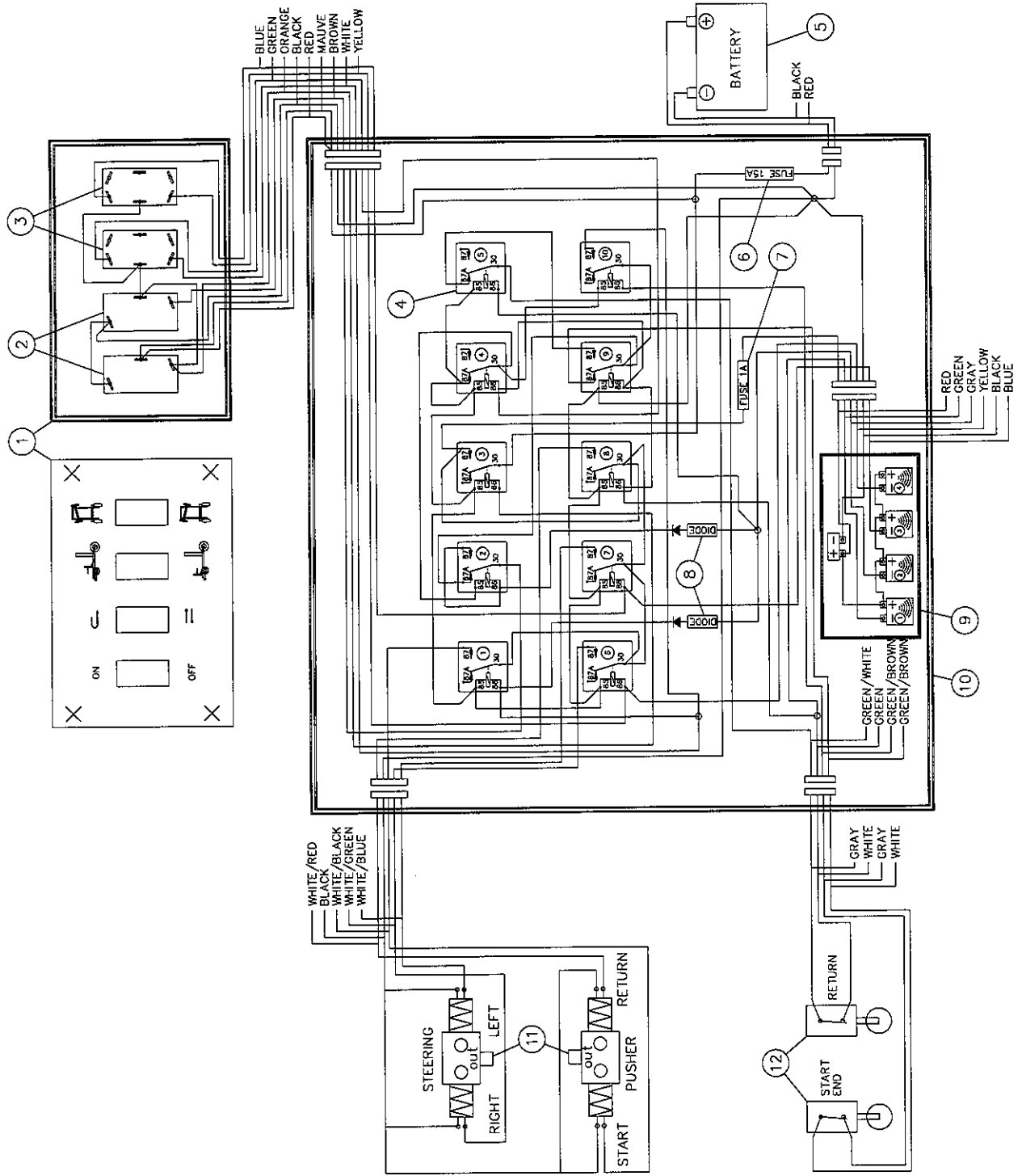

# ***ELECTRIC SYSTEM (cont'd)***

BASE 9200 = Agripac® Lastic Tuber™ without options  
 OPT. 6435 = Hydraulic steering option

REF.	PART #	DESCRIPTION	QTY	
			BASE 9200	OPT. P-6435
1	32245	Manual control sealed box .....	1	-
2	32246	Switch on - off .....	2	-
3	32247	Switch (on) - off - (on) .....	2	-
4	18015	Relay .....	10	-
5	Std.	Battery 12V - 540A .....	1	-
6	32248	Fuse holder 15A .....	1	-
7	32250	Fuse 1A .....	1	-
8	32251	Diode .....	2	-
9	32252	Receiver 4 channel .....	1	-
10	32253	Sealed box .....	1	-
11	18019	Selenoid valve .....	1	1
12	32254	Limit switch .....	2	-
*NI	32255	Transmitter 4 channel .....	1	-
*NI	Std.	Battery for transmitter (Alkaline 12V no. A23) .....	1	-





# ELECTRIC CIRCUIT

## WORKING LIGHTS

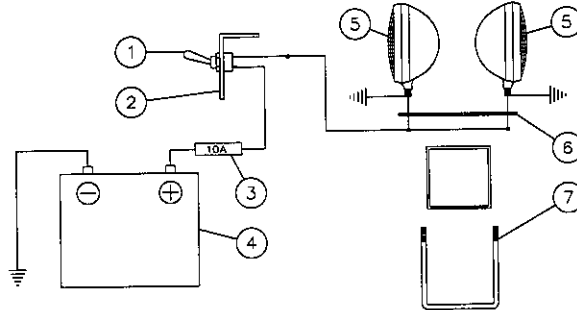

REF.	PART #	DESCRIPTION	QTY
1	32237	Switch ON-OFF .....	1
2	130-04481	Switch support .....	1
3	Std.	Fuse 10A.....	1
4	Std.	Battery 12V-540A.....	1
5	110-04771	Working lights .....	2
6	140-02901	Working lights retaining plate.....	1
7	150-00971	"U" bolt 3/8" NC + 2 nylon locknut.....	1



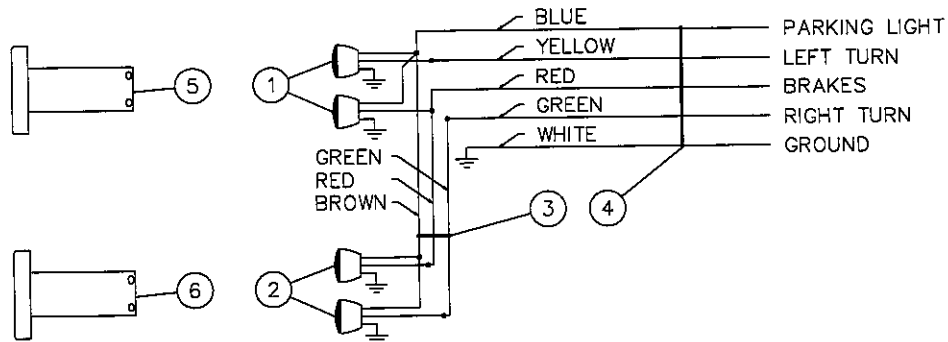



## ROAD LIGHTS







REF.	PART #	DESCRIPTION	QTY
1	32228	Left red flashers with license light .....	2
2	32229	Right red flashers .....	2
3	110-03771	3 conductors cable with terminal 258" lg .....	1
4	110-03591	5 conductors cable with terminal 288" lg .....	1
5	110-03511	Left support for flasher and license light .....	1
6	110-03501	Right support for flasher .....	1

# TORQUE CHART

## TORQUE SPECIFICATION TABLE

Thread UNC and UNF		Grade 2 				Grade 5   				Grade 8*   			
Bolt size		Torque				Torque				Torque			
Inches	mm	Pound feet		Newton meters		Pound feet		Newton meters		Pound feet		Newton meters	
		min.	max.	min.	max.	min.	max.	min.	max.	min.	max.	min.	max.
1/4	6.35	5	6	6.8	8.13	9	11	12.2	14.9	12	15	16.3	30.3
5/16	7.94	10	12	13.6	16.3	17	20.5	23.1	27.8	24	29	32.5	39.3
3/8	9.53	20	23	27.1	31.2	35	42	47.5	57.0	45	54	61.0	73.2
7/16	11.11	30	35	40.7	47.4	54	64	73.2	86.8	70	84	94.9	113.9
1/2	12.70	45	52	61.0	70.5	80	96	108.5	130.2	110	132	149.2	179.0
9/16	14.29	65	75	88.1	101.6	110	132	149.2	179.0	160	192	217.0	260.4
5/8	15.88	95	105	128.7	142.3	150	180	203.4	244.1	220	264	298.3	358.0
3/4	19.05	150	185	203.3	250.7	270	324	366.1	439.3	380	456	515.3	618.3
7/8	22.23	160	200	216.8	271.0	400	480	542.4	650.9	600	720	813.6	976.3
1	25.40	250	300	338.8	406.5	580	696	786.5	943.8	900	1080	1220.4	1464.5
1 1/8	25.58	-	-	-	-	800	880	1084.8	1193.3	1280	1440	1735.7	1952.6
1 1/4	31.75	-	-	-	-	1120	1240	1518.7	1681.4	1820	2000	2467.9	2712.0
1 3/8	34.93	-	-	-	-	1460	1680	1979.8	2278.1	2380	2720	3227.3	3688.3
1 1/2	38.10	-	-	-	-	1940	2200	2630.6	2983.2	3160	3560	4285.0	4827.4

\* Thick nuts must be used with grade 8 bolts.

Size of screw	Thread	Pitch (mm)	Grade 4T  				Grade 7T 				Grade 8T  			
			Torque				Torque				Torque			
			Pound feet		Newton meters		Pound feet		Newton meters		Pound feet		Newton meters	
		min.	max.	min.	max.	min.	max.	min.	max.	min.	max.	min.	max.	
M6	UNC	1.00	3.6	5.8	4.9	7.9	5.8	9.4	7.9	12.7	7.2	10	9.8	13.6
M8	UNC	1.25	7.2	14	9.8	19	17	22	23	29.8	20	26	27.1	35.2
M10	UNC	1.5	20	25	27.1	33.9	34	40	46.1	54.2	38	46	51.5	62.3
M12	UNC	1.75	28	34	37.9	46.1	51	59	69.1	79.9	57	66	77.2	89.4
M14	UNC	2.0	49	56	66.4	75.9	81	93	109.8	126	96	109	130.1	147.7
M16	UNC	2.0	67	77	90.8	104.3	116	130	157.2	176.2	129	145	174.8	196.5
M18	UNC	2.0	88	100	119.2	136	150	168	203.3	227.6	175	194	237.1	262.9
M20	UNC	2.5	108	130	146.3	176.2	186	205	252	277.8	213	249	288.6	337.4
M8	UNF	1.0	12	17	16.3	23	19	27	25.7	36.6	22	31	29.8	42
M10	UNF	1.25	20	29	27.1	39.3	35	47	47.4	63.7	40	52	54.2	70.5
M12	UNF	1.25	31	41	42	55.6	56	68	75.9	92.1	62	75	84	101.6
M14	UNF	1.5	52	64	70.5	86.7	90	106	122	143.6	107	124	145	168
M16	UNF	1.5	69	83	93.5	112.5	120	138	162.6	187	140	158	189.7	214.1
M18	UNF	1.5	100	117	136	158.5	177	199	239.8	269.6	202	231	273.7	313
M20	UNF	1.5	132	150	178.9	203.3	206	242	279.1	327.9	246	289	333.3	391.6

Use the above torques when special torque is not given.

NOTE: These values apply to fasteners as received from supplier, dry, or when lubricated with normal engine oil. They do not apply if extreme pressure lubricants are used.



---

---

# WARRANTY

---

ALBERTA AG-INDUSTRIES LTD. warrants this product to the initial purchaser for the period of one year from the date of purchase against defects in materials and workmanship.

We will replace or repair defective parts free of charge if they are returned to ALBERTA-AG INDUSTRIES LTD. 10012 - 93 rd Avenue, Westkock, AB, T7P 2P2 unless instructed otherwise.

Transportation charges are the responsibility of the customer. This warranty is not transferable.

Tires and gasoline engine are covered by the manufacturers of these items.

All ALBERTA AG-INDUSTRIES LTD. spare parts purchased are covered by a three (3) month warranty.

This warranty becomes void and nul if the equipment is modified, breaks down as result of an accident, if not operated according to manufacturer's recommendations, damaged by negligence or if maintenance has not been carried out as specified.

Our obligation is limited to the replacement or repair of the defective part. ALBERTA AG-INDUSTRIES LTD. accepts no responsibility for direct or indirect consequential damages of any kind.







Copyright © Alberta Ag-Industries Ltd., 1997

All rights reserved.  
Printed in Canada.