

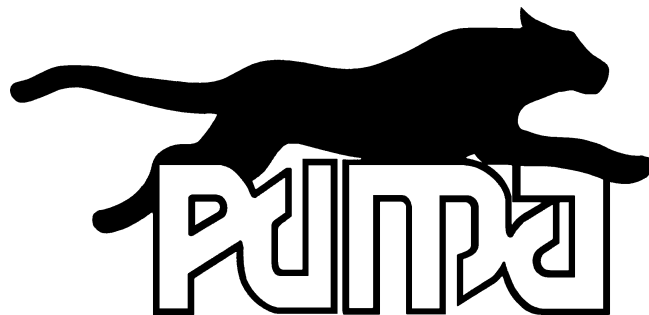

**OPERATOR'S / PARTS
MANUAL**



Dump Trailer
Model

PUMA-LP12

PUMA-LP12GN

VISIT OUR WEBSITE



www.pronovost.qc.ca

Copyright © Les Machineries Pronovost Inc., 2008

All rights reserved.
Printed in Canada.

TABLE OF CONTENTS

Section	Item	Page
1	Introduction	5
2	Safety	6
	General Safety	6
	Safety in Operation	6
	Safety with Maintenance	7
	Safety in Transport	7
3	Decals	8
	Safety Decals	8
	Maintenance Decals	9
4	Start-up	10
	Basic Start-up Procedures	10
5	Maintenance	11
6	Storage	12
7	Specifications	13
8	Parts List	14
	Dump Trailer PUMA-LP12	14
	Dump Trailer PUMA-LP12GN	17
	Electric circuit	21
	Cylinder 30BC28	22
	Electric hydraulic pump	23
9	Torque Chart	25
10	Warranty	26

INTRODUCTION

CONGRATULATIONS!

Thank you for choosing PRONOVOST. We are confident this equipment will meet your requirements in terms of quality, performance and reliability.

This manual was prepared to assist you in the safe operation of your new Dump Trailer. It contains important information which will help you achieve excellent returns with your PRONOVOST Dump Trailer for years to come.

Please read this manual before operating your Trailer and keep it for future reference.

Before using this equipment, you or any other person who will be using it must familiarize yourself with the safety recommendations, the operating and safety instructions. Please read carefully and be sure to understand and follow all recommendations and procedures.

In this manual, the right and left sides are identified while standing at the rear end of the equipment and facing it.

If you require additional information on your Dump Trailer, please contact your PRONOVOST Dealer.

NOW take a moment to enter the model, serial number and the date of purchase of your Trailer in the space provided below.

When ordering parts from your Dealer, please refer to these numbers for a fast and efficient service. Use PRONOVOST parts for replacement.

The model and serial numbers are on the name plate shown on Fig. 1.



Figure 1

MODEL: _____ ✍

SERIAL NO: _____ ✍

DATE OF PURCHASE: _____ ✍

SAFETY

GENERAL SAFETY

2

WHEN YOU SEE THIS SYMBOL



ATTENTION!

**BE ALERT
YOUR SAFETY IS INVOLVED**

This symbol "**SAFETY ALERT**" is used in this manual and on the safety decals on the Trailer. It warns you of the possibility of danger. Carefully read, understand and follow all safety recommendations before operating the equipment.

- 1) Careful operation is the best assurance against accidents. Carefully read this manual and follow all recommendations before operating this equipment. It is the owner's responsibility to make sure that anyone who will operate the Trailer will read this manual before operating the equipment.
- 2) Do not modify the equipment. Any non authorized modification may affect the efficiency and/or safety of the equipment.
- 3) Never operate the equipment with defective parts or if damaged in any way. Have it repaired before using it.
- 4) Make sure all fasteners are in place and properly secured or tightened. Refer to torque chart on page 25.
- 5) Hydraulic fluids under pressure can damage your skin. Do not use your hands to locate a leak.
- 6) Battery (with 12V hydraulic system) contains

sulfuric acid. Avoid contact with skin, eyes or clothing.

SAFETY IN OPERATION

- 1) **WARNING!** Do not overload your trailer, do not exceed the load capacity indicated in the specifications on page 13.
- 2) Be sure there are no obstructions around the equipment and that no one stands near the equipment when in use.
- 3) Do not operate an engine in a confined or non ventilated area.
- 4) Do not perform any adjustments, cleaning, maintenance or repairs with the engine running on the towing vehicle. Preferably remove the key from the ignition.
- 5) Be careful when backing-up, make sure you have good visibility.
- 6) Make sure the suspension, brakes and lights are all functioning properly.
- 7) Do not forget to unlock the proper panel lock before dumping.
- 8) Always travel at a safe operating speed following regulations and common sense.
- 9) Check battery charge regularly to insure proper functioning of emergency brakes. Ideal charge: 12.66 volts.

SAFETY (cont'd)

SAFETY WITH MAINTENANCE

- 1) Perform maintenance according to recommendations contained in this manual.
- 2) **Before performing any work under the raised platform, always install the safety prop provided.**
- 3) If the trailer is hooked up to the vehicle while performing maintenance work, make sure the engine is not running and preferably remove the ignition key.

SAFETY IN TRANSPORT

- 1) Be alert while driving on the road. Never carry passengers in the trailer.
- 2) It is prohibited to circulate on public roads with rear panel tied off to side of trailer.

2

DECALS

SAFETY DECALS

The safety decals are affixed wherever special safety precautions are indicated. Locate them on the equipment and read them carefully. If a decal is damaged, lost or illegible, install a new one. The following photos indicate where each one must be installed.

3

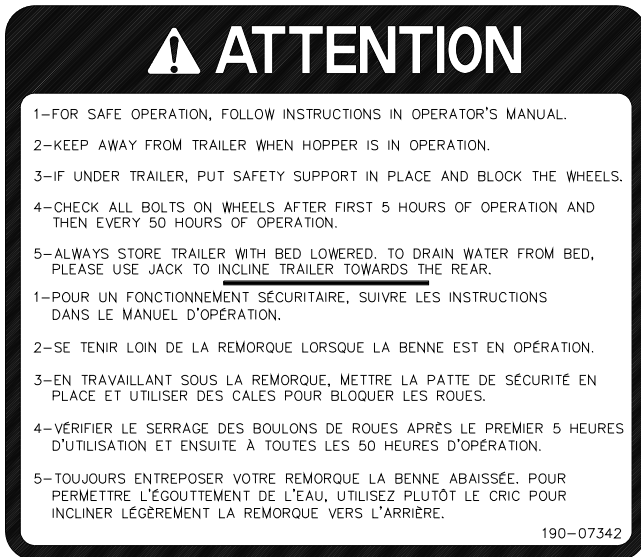

Figure 2
Decal A

Part no.: 190-07342



Figure 4



Figure 5
Decal C

Part no.: 190-05761

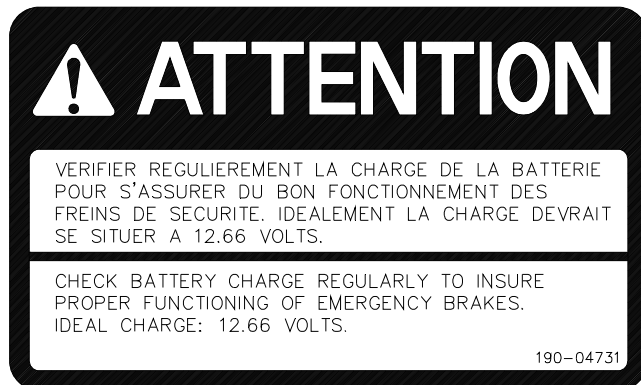

Figure 3
Decal B

Part no.: 190-04731

DECALS



Figure 5
Decal D

Part no.: 190-04521



Figure 7

MAINTENANCE DECALS

The maintenance decals indicate the points requiring lubrication. Refer to maintenance section for more details.



Figure 7

Part no.: A 105



Figure 8

Part no.: A 106

3

START-UP

BASIC START-UP PROCEDURES

- 1) Lubricate all grease fittings with a good quality multiuse grease.
- 2) Lubricate panel release mechanism with good quality oil.
- 3) Adjust tire pressure to manufacturer's specifications.
- 4) Install wheels on hubs.
- 5) Install panels.
- 6) Verify for adequate tightness of all fastening devices. Refer to torque chart on page 25.
- 7) Check oil level in hydraulic reservoir. Use DEXTRON III or equivalent.
- 8) Check battery charge regularly to insure proper functioning of emergency brakes. Ideal charge: 12.66 volts.
- 9) Do not forget to unlock the proper panel lock before dumping.

4

MAINTENANCE

Before performing any work under the raised platform, always install the safety prop provided.

- 1) Wipe off all grease fittings with a clean cloth before adding grease in order to avoid injecting dirt or sand.
- 2) Repair or replace damaged grease fittings.
- 3) Lubricate all grease fittings every 20 hours of operation.
- 4) Check all bolts on wheels after first 5 hours of operation and then every 50 hours of operation.
- 5) Lubricate panel release mechanism every 20 hours of operation.
- 6) Check tire pressure every 50 hours of operation, adjust according to recommendation indicated on the tires.
- 7) Check brakes once a year and adjust or repair if necessary.
- 8) Open, clean and lubricate wheel bearings once a year.
- 9) Check all nuts and bolts once a year. If necessary use torque chart on page 25.
- 10) Check oil level in hydraulic reservoir. Use DEXTRON III or equivalent.
- 11) Check battery charge regularly to insure proper functioning of emergency brakes. Ideal charge: 12.66 volts.

STORAGE

- 1) Store in a cool, dry place.
- 2) Install wooden blocks under the axles to keep the tires off the ground and cover them if left exposed to the sun.
- 3) Keep all piston rods in the retracted position. This will assure better protection against the elements.
- 4) Clean your trailer.
- 5) Thoroughly inspect all parts of the trailer. Replace or repair worn or defective parts.
- 6) Touch-up or repaint if necessary.
- 7) Lubricate all points before storage.

SPECIFICATIONS

MODEL	PUMA-LP12	PUMA-LP12GN
Gross vehicle weight	12 000 lbs (5443 kg)	
Interior dimensions of box	80" x 144" (2032 x 3658 mm)	
Bed	10 G	
Panels front and sides	18" (457 mm) x 14 G	
Rear door standard (removable)	18" x 14 G	
Rear door	2 doors opening to the side / swing out from bottom	
Rear door option	Folding ramp for light equipment (cap. 725 lbs), swings out from bottom for dumping	
Platform height	28" (711 mm)	
Clearance of platform at maximum tilt	13" (330 mm)	
Over-all length	201" (5105 mm)	244 5/8" (6213 mm)
Over-all width	102" (2591 mm)	
Over-all height (box down)	46 3/8" (1178 mm)	75" (1905 mm)
Over-all height (at maximum tilt)	133" (3378 mm)	
Tread width c/c	92 1/2" (2349 mm)	
Dumping angle	47 deg.	
Suspension	Slip springs	
Wheels dimensions	16" x 6" - 8 boulons	
Tires	4 x ST235 / 85R16	
Ball hitch (adjustable height)	Ball 2 5/16"	
Manual jack	3 300 lbs	12 000 lbs
Electric brakes (on 4 wheels)	Standard	
Signal lights (12V)	Standard	
Oil volume required	2.5 gal US / 9.5 litres	
Cylinder	2 x 3" simple action	
Electric hydraulic pump 12V with hand held switch + 6' lead	Standard	
App. total weight	3 500 lbs (1587 kg)	4 000 lbs (1814 kg)

Design and specifications subject to change without notice.

TRAILER PUMA-LP12

170-02993R1

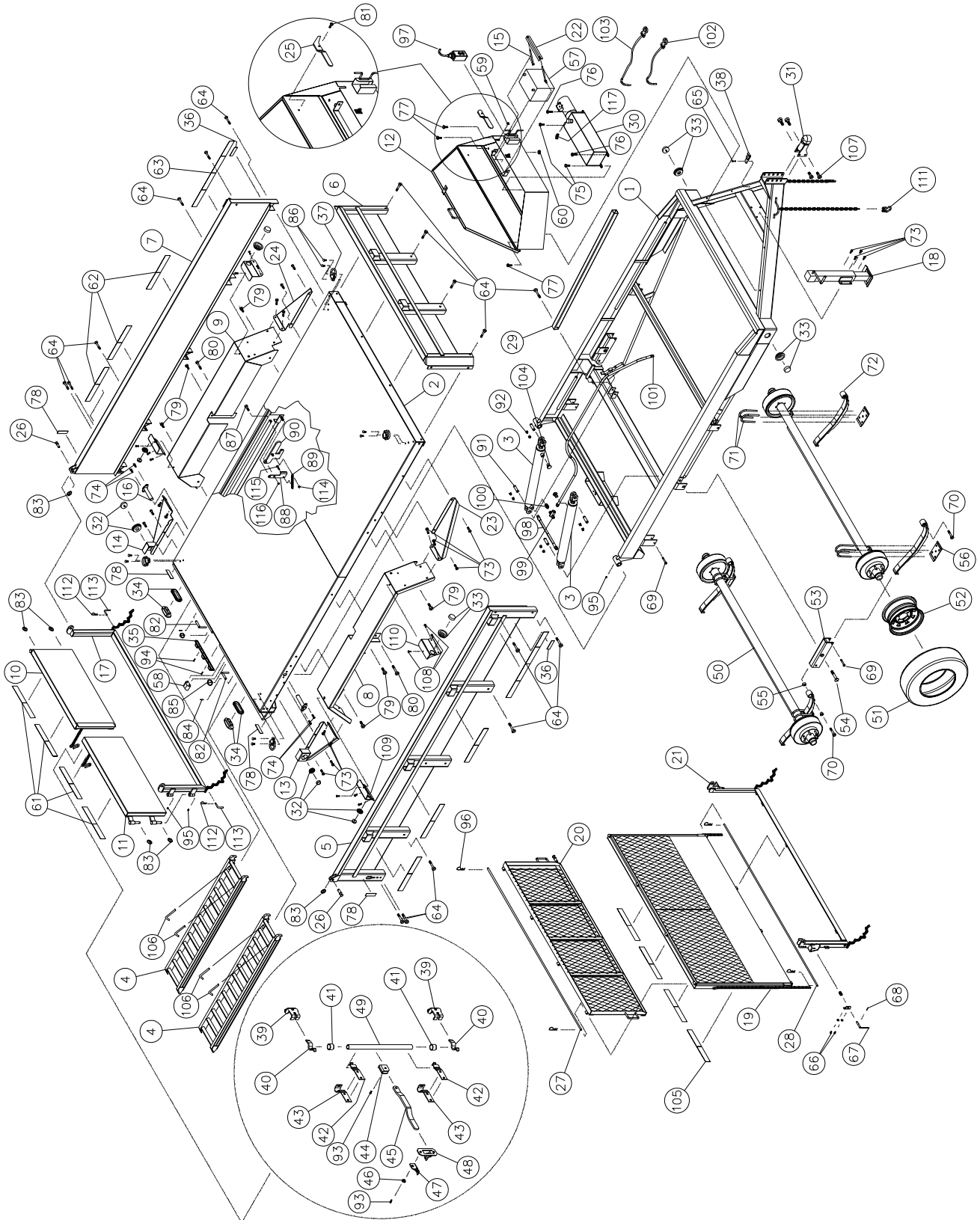

TRAILER PUMA-LP12 (cont'd)

RÉF.	# DE PIÈCE	DESCRIPTION	QTE
1	120-04181	Frame	1
2	120-04171	Platform	1
3	30BC28	Cylinder 3" x 28" stroke	2
4	110-19411	Ramps	2
5	110-19441	Panel (right side)	1
6	110-19631	Front panel	1
7	110-19691	Panel (left side)	1
8	110-19741	Right fender	1
9	110-19751	Left fender	1
10	110-19761	Standard rear panel (left side door)	1
11	110-19771	Standard rear panel (right side door)	1
12	110-21851	Box	1
13	110-19851	Right rear step	1
14	110-19852	Left rear step	1
15	110-19981	Battery support rod + nut 3/8"	2
16	110-20021	Clevis pin	2
17	110-20201	Frame for standard rear panel	1
18	110-20421	Jack 3300 lbs	1
19	110-20861	Expanded metal door	opt.
20	110-20871	Expanded metal half-door	opt.
21	110-20881	Frame for expanded metal door	opt.
22	130-05751	Battery support	1
23	130-27851	Right front step	1
24	130-27852	Left front step	1
25	130-29584	Cover holder	1
26	150-02831	Rear panel clevis pin	2
27	150-04861	Hinge rod	opt.
28	150-04881	Hinge rod	opt.
29	160-10161	Safety support	1
30	54014	Electric hydraulic pump	1
31	51615	Ball hitch 2 5/16"	1
32	54017	Red marker lamp + mounting ring	2
33	54018	Yellow marker lamp + mounting ring	4
34	54016	Signal light + mounting ring	2
35	54035	3 marker lamp plate	1
36	10133	Yellow reflector	2
37	54021	Cargo latching ring	4
38	52069	Emergency brake switch	1
39	54029	Keeper	2
40	54026	Cam	2
41	54022	Spacer	2
42	54028	Lower guide	2
43	54027	Rod guide	2
44	54025	Handle hold down	1
45	54023	Handle	1
46	54024	Spacer	1
47	54031	Lock plate	1
48	54030	Handle support	1
49	160-10031	Lock rod	1
50	110-19522	Axle assembly with hubs and brakes	2
51	PN-23585R16	Tire LT23585R16	4
52	RM-1668	Rim 16" x 6"- 6 bolts	4
53	54054	Spring pivot	2
54	54055	Pivot pin	2
55	54056	Bushing	8
56	51599	Spring back plate	4
57	51614	Battery 12 Volts 850 Amp. Deep cycle	1
58	54057	License plate light	1
59	54032	Grommet 7/16"	1
60	54033	Grommet 3/4"	1

TRAILER PUMA-LP12 (cont'd)

REF.	PART #	DESCRIPTION	QTY
61	54058	Reflector 17"	4
62	54059	Reflector 18"	6
63	54060	Reflector 35"	2
64	300-40430	Bolt 1/2" NC PL x 3 1/2" lg + nylon locknut	17
65	300-32220	Bolt 1/4" NC PL x 3/4" lg + nylon locknut	1
66	300-34250	Bolt 5/16" NC x 1" lg + flat washer + nylon locknut	4
67	110-20911	Gate handle	opt.
68	Std.	Roll pin 3/16"	opt.
69	300-34400	Bolt 5/16" NC x 3" lg + nylon locknut	4
70	300-44430	Bolt 5/16" NC x 3 1/2" lg + nylon locknut	4
71	Std.	"U" bolt 1/2" NF x 3" x 7" dia. + 2 nylon locknut	8
72	54010	Slip springs	4
73	300-38250	Bolt 7/16" NC PL x 1" lg + nylon locknut	20
74	300-36250	Bolt 3/8" NC x 1" lg + lock washer	4
75	300-36220	Bolt 3/8" NC x 3/4" lg + flat washer + nylon locknut	2
76	300-36250	Bolt 3/8" NC x 1" lg + flat washer + nylon locknut	2
77	300-36250	Bolt 3/8" NC x 1" lg + nylon locknut	3
78	10132	Red reflector	2
79	300-40250	Bolt 1/2" NC x 1" lg + nylon locknut	6
80	300-40460	Bolt 1/2" NC x 4" lg + nylon locknut	2
81	300-35240	Bolt 5/16" x 1" lg. + nylon locknut	2
82	110-19871	Ramp lock	2
83	Std.	Lynch pin 3/16"	6
84	Std.	Roll pin 3/16" x 1 1/4"	2
85	Std.	Lynch pin 1/4"	2
86	321-36280	Carriage bolt 3/8" x 1 1/4" lg + nylon locknut	8
87	300-40340	Bolt 1/2" NC x 2" lg + nylon locknut	1
88	130-28851	Auto-lock plate	1
89	190-02351	Auto-lock spring	1
90	110-20711	Auto-lock pivot	1
91	51421	Clevis pin 1"	4
92	51472	Hitch pin clip (CP132H)	8
93	54061	Shoulder screw	2
94	322-20220	Bolt 10-24 x 3/4"	2
95	Std.	Grease fitting 1/4" droit	6
96	Std.	Hairpin cotter 1/8"	opt.
97	54007	Hand held control	1
98	190-05821	Hose 3/8" x 47 1/2" + 2 fittings 6U106	1
99	5856-6x6x6	"T" fitting	1
100	3069-6x6	Fitting	1
101	190-05831	Hose 3/8" x 134" + 2 fitting 6U106	1
102	51631	Battery cable 15"	1
103	51606	Battery cable 30"	1
104	54082	Vent plug 3/8" NPT	2
105	54058	Reflector 17" lg	opt.
106	150-04981	Ramp safety pin	4
107	300-44310	Bolt 5/8" NC x 1 1/2" lg + nylon locknut	4
108	300-36220	Bolt 3/8" NC x 3/4" lg + nylon locknut	12
109	130-30641	Light support	2
110	130-30671	Light support	2
111	54072	Safety hook	2
112	Std.	Hairpin cotter	2
113	150-02861	Pin for rear locking mechanism	2
114	346-40000	Nylon locknut 1/2" NC	2
115	300-40310	Bolt 1/2" NC x 1 1/2" lg + nylon locknut	1
116	346-44000	Nylon locknut 5/8" NC	1
117	9355x6x6	Elbow 45° swivel	1

TRAILER PUMA-LP12GN

170-03333R1

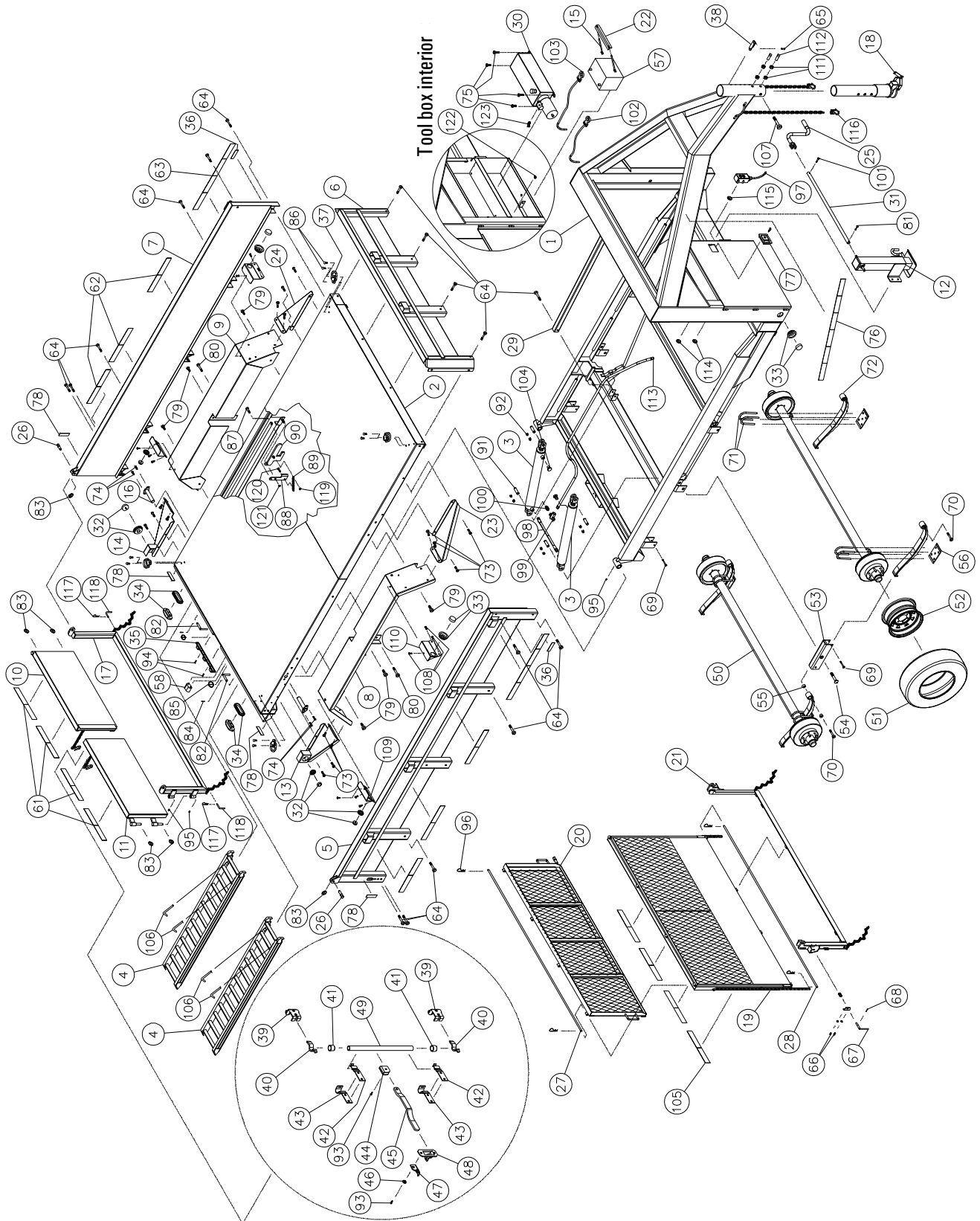

TRAILER PUMA-LP12GN (cont'd)

REF.	PART #	DESCRIPTION	QTY
1	120-04341	Frame	1
2	120-04171	Platform	1
3	30BC28	Cylinder 3" x 28" stroke	2
4	110-19411	Ramps	2
5	110-19441	Panel (right side)	1
6	110-19631	Front panel	1
7	110-19691	Panel (left side)	1
8	110-19741	Right fender	1
9	110-19751	Left fender	1
10	110-19761	Standard rear panel (left side door)	1
11	110-19771	Standard rear panel (right side door)	1
12	110-21551	Jack 12 000 lbs (adjustable base)	1
13	110-19851	Right rear step	1
14	110-19852	Left rear step	1
15	110-19981	Battery support rod + nut 3/8"	2
16	110-20021	Clevis pin	2
17	110-20201	Frame for standard rear panel	1
18	54066	Goose neck	1
19	110-20861	Expanded metal door	opt.
20	110-20871	Expanded metal half-door	opt.
21	110-20881	Frame for expanded metal door	opt.
22	130-05751	Battery support	1
23	130-27851	Right front step	1
24	130-27852	Left front step	1
25	190-06661	Hand crank	1
26	150-02831	Rear panel clevis pin	2
27	150-04861	Hinge rod	opt.
28	150-04881	Hinge rod	opt.
29	160-10161	Safety support	1
30	54014	Electric hydraulic pump	1
31	160-10831	Jack handle extension	1
32	54017	Red marker lamp + mounting ring	2
33	54018	Yellow marker lamp + mounting ring	4
34	54016	Signal light + mounting ring	2
35	54035	3 marker lamp plate	1
36	10133	Yellow reflector	2
37	54021	Cargo latching ring	4
38	52069	Emergency brake switch	1
39	54029	Keeper	2
40	54026	Cam	2
41	54022	Spacer	2
42	54028	Lower guide	2
43	54027	Rod guide	2
44	54025	Handle hold down	1
45	54023	Handle	1
46	54024	Spacer	1
47	54031	Lock plate	1
48	54030	Handle support	1
49	160-10031	Lock rod	1
50	110-19522	Axle assembly with hubs and brakes	2
51	PN-23585R16	Tire LT23585R16	4

TRAILER PUMA-LP12GN (cont'd)

REF.	PART #	DESCRIPTION	QTY
52	RM-1668	Rim 16" x 6" - 8 bolts	4
53	54054	Spring pivot	2
54	54055	Pivot pin	2
55	54056	Bushing	8
56	51599	Spring back plate	4
57	51614	Battery 12 Volts 850 Amp. Deep cycle	1
58	54057	License plate light	1
59	54032	Rubber grommet 7/16"	1
60	54033	Rubber grommet 3/4"	1
61	54058	Reflector 17"	4
62	54059	Reflector 18"	6
63	54060	Reflector 35"	2
64	300-40430	Bolt 1/2" NC PL x 3 1/2" lg + nylon locknut	17
65	300-32220	Bolt 1/4" NC PL x 3/4" lg + nylon locknut	1
66	300-34250	Bolt 5/16" NC x 1" lg + flat washer + nylon locknut	4
67	110-20911	Gate handle	opt.
68	Std.	Roll pin 3/16"	opt.
69	300-34400	Bolt 5/16" NC x 3" lg + nylon locknut	4
70	300-44430	Bolt 5/8" NC x 3 1/2" lg + nylon locknut	4
71	Std.	"U" bolt 1/2" NF x 3" x 7" dia. + 2 nylon locknut	8
72	54010	Slip springs	4
73	300-38250	Bolt 7/16" NC PL x 1" lg + nylon locknut	20
74	300-36250	Bolt 3/8" NC x 1" lg + lock washer	4
75	300-36220	Bolt 3/8" NC x 3/4" lg + flat washer + nylon locknut	2
76	84068	Reflector	2
77	Std.	Cabinet lock	3
78	10132	Red reflector	2
79	300-40250	Bolt 1/2" NC x 1" lg + nylon locknut	6
80	300-40460	Bolt 1/2" NC x 4" lg + nylon locknut	2
81	34310	Bolt 5/16" x 1 1/2" lg + nylon locknut	2
82	110-19871	Ramp lock	2
83	Std.	Lynch pin 3/16"	6
84	Std.	Roll pin 3/16" x 1 1/4"	2
85	Std.	Lynch pin 1/4"	2
86	321-36280	Carriage bolt 3/8" x 1 1/4" lg + nylon locknut	8
87	300-40340	Bolt 1/2" NC x 2" lg + nylon locknut	1
88	130-28851	Auto-lock plate	1
89	190-02351	Auto-lock spring	1
90	110-20711	Auto-lock pivot	1
91	51421	Clevis pin 1"	4
92	51472	Hitch pin clip (CP132H)	8
93	54061	Shoulder screw	2
94	322-20220	Bolt 10-24 x 3/4"	2
95	Std.	Grease fitting 1/4" droit	6
96	Std.	Hairpin cotter 1/8"	opt.
97	54007	Hand held control	1
98	190-05821	Hose 3/8" x 47 1/2" + 2 fittings 6U106	1
99	5856-6x6x6	"T" fitting	1
100	3069-6x6	Fitting	1
101	306-46550	Bolt 3/4" NC x 5 1/2" + nylon locknut	1
102	51631	Battery cable 15"	1

TRAILER PUMA-LP12GN (cont'd)

REF.	PART #	DESCRIPTION	QTY
103	51606	Battery cable 30"	1
104	54082	Vent plug 3/8" NPT	2
105	54058	Reflector 17" lg	opt.
106	150-04981	Ramp safety pin	4
107	300-34370	Bolt 5/16" NC x 2 1/2" lg + nylon locknut	4
108	300-36220	Bolt 3/8" NC x 3/4" lg + nylon locknut	12
109	130-30641	Light support	2
110	130-30671	Light support	2
111	346-46000	Nylon locknut 3/4"	4
112	300-46340	Bolt 3/4" NC x 2" lg	2
113	190-06101	Hose 3/8" x 161" lg + 2 fitting 6U106	1
114	Std.	Rubber grommet 1" ins. dia. x 1 3/8" out. dia. x 1/4" thick	1
115	Std.	Rubber grommet 7/16" ins. dia. x 7/8" out. dia. x 3/32" thick	1
116	54072	Safety hook	2
117	Std.	Hairpin cotter	2
118	150-02861	Pin for rear locking mechanism	2
119	346-40000	Nylon locknut 1/2" NC	2
120	300-40310	Bolt 1/2" NC x 1 1/2" lg + nylon locknut	1
121	346-44000	Nylon locknut 5/8" NC	1
122	Std.	Rubber grommet 9/16" ins. dia. x 13/16" out. dia. x 1/8" thick	1
123	9355x6x6	Elbow 45° swivel	1

ELECTRIC CIRCUIT PUMA-LP12

170-03301

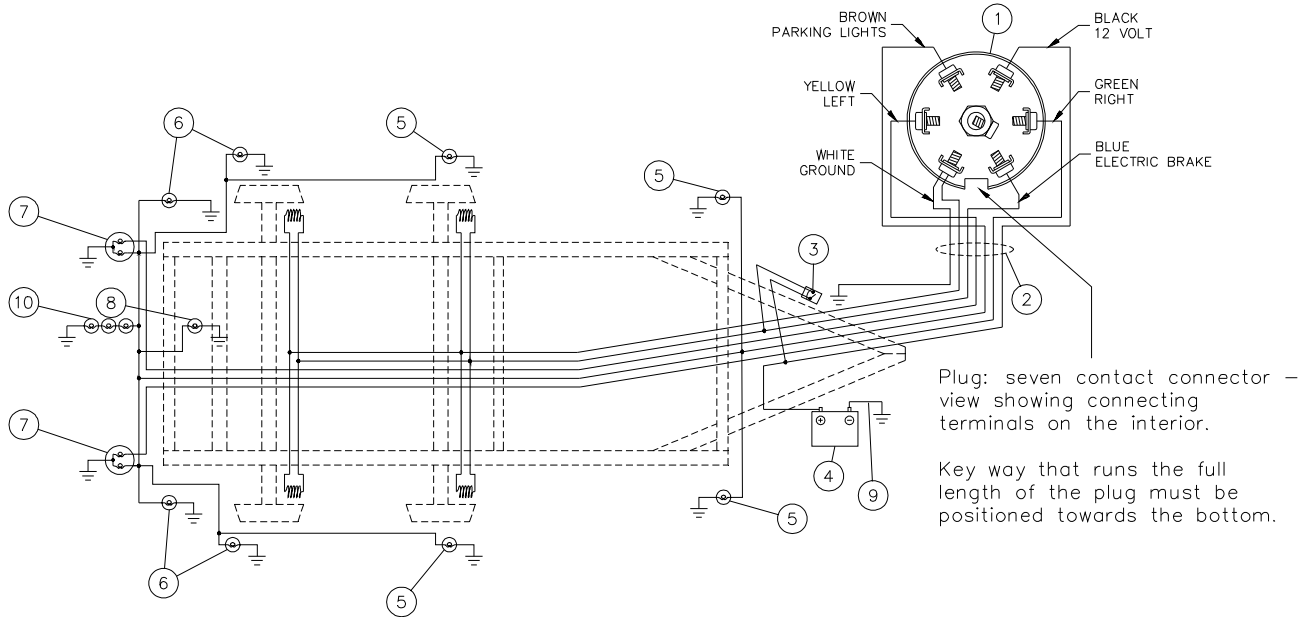

EF.	PART #	DESCRIPTION	QTY
1	52065	Connector 7 poles	1
2	54036	PUMA-LP12 conductor cable kit	1
3	52069	Emergency brake switch	1
4	51614	Battery 12 volts 850 Amp	1
5	54018	Yellow parking light	4
6	54017	Red parking light.....	4
7	54016	Signal light.....	2
8	52070	License plate	1
9	51607	Battery cable 4 GA. x 10" Lg.	1
10	54035	3 marker light plate	1



CYLINDER 30BC28

170-01911

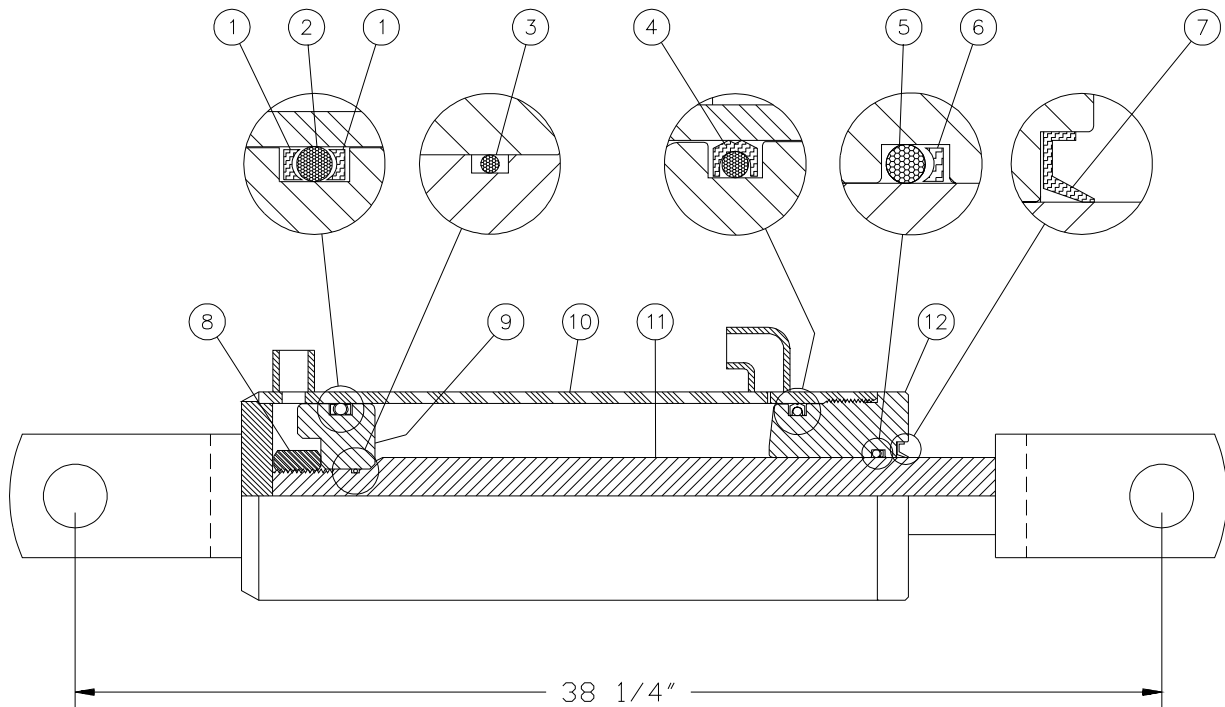

REF.	PART #	DESCRIPTION	QTY
1	BU-334	Back-up 3/16" x 2 5/8" x 3"	2
2	OR-334	O-ring 3/16" x 2 5/8" x 3"	1
3	OR-018	O-ring 1/16" x 3/4" x 7/8"	1
4	PSP-334	O-ring 3/16" x 2 5/8" x 3"	1
5	OR-218	O-ring 1/8" x 1 1/4" x 1 1/2"	1
6	BU-218	Back-up 1/8" x 1 1/4" x 1 1/2"	1
7	CR12330	Racleur 1/8" x 1 1/4" x 1 1/2"	1
8	Std.	Wiper 7/8" NF	1
9	150-02371	Piston 3" dia.	1
10	110-12161	Cylinder body 3" for 30BC28 with 1 fitting 3/8" NPT straight & 1 fitting 3/8" NPT 90 deg.	1
11	110-11641	Piston rod 1 1/4" for 30BC28	1
12	150-02381	Head 3" dia.	1
NI*	51444	Seal kit (includes # 1 to 7)	1

*NI = Not illustrated

8

ELECTRIC HYDRAULIC PUMP # 54014 (M-303-016-03G01E)

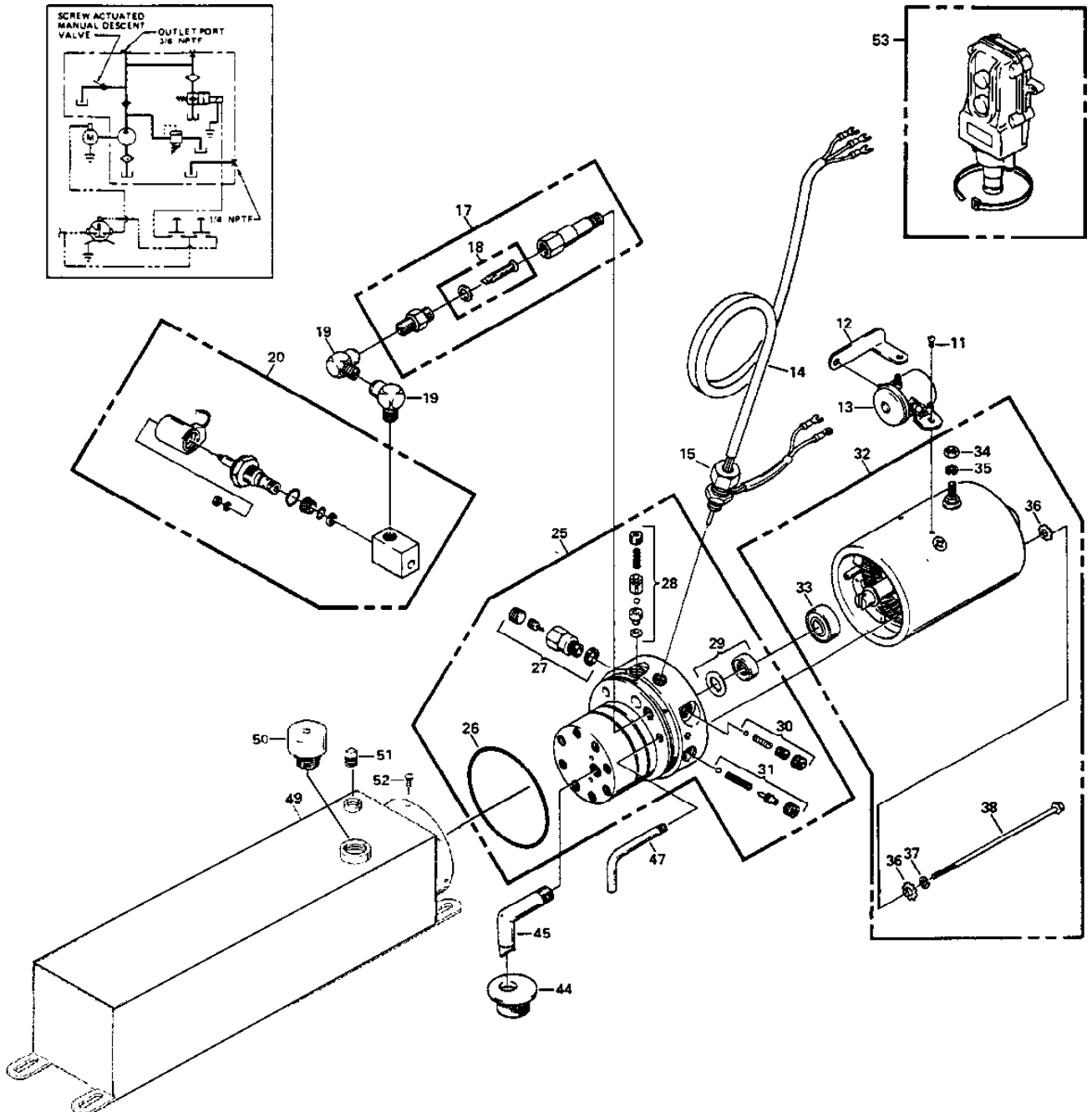

8

ELECTRIC HYDRAULIC PUMP # 54014 (M-303-016-03G01E)







REF.	PART #	DESCRIPTION	QTY
11	Std.	Screw 10-32 x 1/4"	2
12	54037	Connecting strap	1
13	54038	Switch 3-post	1
14	54039	Harness for push button box	1
15	54040	Strain relief fitting	1
17	54041	Filter assembly	1
18	54042	Gasket and filter	1
19	Std.	Elbow 1/4" NPT	2
20	54043	Valve assembly, two way, two positions 12V DC	1
25	54044	Pump assembly (code 03)	1
26	51544	O-ring 3 5/8" x 3 7/8" x 1/8"	1
27	54045	Manual override	1
28	54046	Main check valve	1
29	54047	Seal and gasket	1
30	54048	Descending check valve	1
31	54049	Relief valve	1
32	54050	Electric motor 12V DC	1
33	51551	Ball bearing	1
34	Std.	Nut 5/16"-24	1
35	Std.	Lock washer 5/16"	1
36	Std.	Star washer 1/4"	4
37	Std.	Lock washer 1/4"	2
38	Std.	Bolt 1/4"-20 x 6 1/2" lg	2
44	51552	Filter	1
45	51553	Suction tube	1
47	51554	Return tube	1
49	54051	Reservoir PUMA-LP12 (715 po ³)	1
50	51556	Vent plug 3/4" NPT	1
51	51557	Square head plug 1/4" NPT	1
52	Std.	Screw 10-24 x 3/8"	6
53	54007	Hand held control	1







* Some parts might not be available apart.

TORQUE CHART

TORQUE SPECIFICATION TABLE

Thread UNC and UNF		Grade 2 				Grade 5   				Grade 8*   			
Bolt size		Torque				Torque				Torque			
Inches	mm	Pound feet min.	max.	Newton meters min.	max.	Pound feet min.	max.	Newton meters min.	max.	Pound feet min.	max.	Newton meters min.	max.
1/4	6.35	5	6	6.8	8.13	9	11	12.2	14.9	12	15	16.3	30.3
5/16	7.94	10	12	13.6	16.3	17	20.5	23.1	27.8	24	29	32.5	39.3
3/8	9.53	20	23	27.1	31.2	35	42	47.5	57.0	45	54	61.0	73.2
7/16	11.11	30	35	40.7	47.4	54	64	73.2	86.8	70	84	94.9	113.9
1/2	12.70	45	52	61.0	70.5	80	96	108.5	130.2	110	132	149.2	179.0
9/16	14.29	65	75	88.1	101.6	110	132	149.2	179.0	160	192	217.0	260.4
5/8	15.88	95	105	128.7	142.3	150	180	203.4	244.1	220	264	298.3	358.0
3/4	19.05	150	185	203.3	250.7	270	324	366.1	439.3	380	456	515.3	618.3
7/8	22.23	160	200	216.8	271.0	400	480	542.4	650.9	600	720	813.6	976.3
1	25.40	250	300	338.8	406.5	580	696	786.5	943.8	900	1080	1220.4	1464.5
1 1/8	25.58	-	-	-	-	800	880	1084.8	1193.3	1280	1440	1735.7	1952.6
1 1/4	31.75	-	-	-	-	1120	1240	1518.7	1681.4	1820	2000	2467.9	2712.0
1 3/8	34.93	-	-	-	-	1460	1680	1979.8	2278.1	2380	2720	3227.3	3688.3
1 1/2	38.10	-	-	-	-	1940	2200	2630.6	2983.2	3160	3560	4285.0	4827.4

* Thick nuts must be used with grade 8 bolts.

Size of screw	Thread	Pitch (mm)	Grade 4T  				Grade 7T 				Grade 8T  			
			Torque				Torque				Torque			
			Pound feet min.	max.	Newton meters min.	max.	Pound feet min.	max.	Newton meters min.	max.	Pound feet min.	max.	Newton meters min.	max.
M6	UNC	1.00	3.6	5.8	4.9	7.9	5.8	9.4	7.9	12.7	7.2	10	9.8	13.6
M8	UNC	1.25	7.2	14	9.8	19	17	22	23	29.8	20	26	27.1	35.2
M10	UNC	1.5	20	25	27.1	33.9	34	40	46.1	54.2	38	46	51.5	62.3
M12	UNC	1.75	28	34	37.9	46.1	51	59	69.1	79.9	57	66	77.2	89.4
M14	UNC	2.0	49	56	66.4	75.9	81	93	109.8	126	96	109	130.1	147.7
M16	UNC	2.0	67	77	90.8	104.3	116	130	157.2	176.2	129	145	174.8	196.5
M18	UNC	2.0	88	100	119.2	136	150	168	203.3	227.6	175	194	237.1	262.9
M20	UNC	2.5	108	130	146.3	176.2	186	205	252	277.8	213	249	288.6	337.4
M8	UNF	1.0	12	17	16.3	23	19	27	25.7	36.6	22	31	29.8	42
M10	UNF	1.25	20	29	27.1	39.3	35	47	47.4	63.7	40	52	54.2	70.5
M12	UNF	1.25	31	41	42	55.6	56	68	75.9	92.1	62	75	84	101.6
M14	UNF	1.5	52	64	70.5	86.7	90	106	122	143.6	107	124	145	168
M16	UNF	1.5	69	83	93.5	112.5	120	138	162.6	187	140	158	189.7	214.1
M18	UNF	1.5	100	117	136	158.5	177	199	239.8	269.6	202	231	273.7	313
M20	UNF	1.5	132	150	178.9	203.3	206	242	279.1	327.9	246	289	333.3	391.6

Use the above torques when special torque is not given.

NOTE: These values apply to fasteners as received from supplier, dry, or when lubricated with normal engine oil. They do not apply if extreme pressure lubricants are used.

WARRANTY

PRONOVOST warrants this product to the initial purchaser for the period of one year from the date of purchase against defects in materials and workmanship.

We will replace or repair defective parts free of charge if they are returned to our plant in St-Tite, Quebec, Canada.

Transportation charges are the responsibility of the customer. This warranty is not transferable.

Hydraulic cylinders are covered by the manufacturer of these items.

All PRONOVOST spare parts purchased are covered by a three (3) month warranty.

This warranty becomes void and nul if the equipment is modified, breaks down as the result of an accident, is not operated according to manufacturer's recommendations, damaged by negligence or if maintenance has not been carried out as specified.

Our obligation is limited to the replacement or repair of the defective part. PRONOVOST accepts no responsibility for direct or indirect consequential damages of any kind.

Ce manuel est aussi disponible en français.
Veuillez téléphoner.



INNOVATION - EXCELLENCE

LES MACHINERIES PRONOVOST INC.

260, route 159,

Saint-Tite, Quebec, Canada, G0X 3H0

Tel.: (418) 365-7551, Fax: (418) 365-7954

www.pronovost.qc.ca