

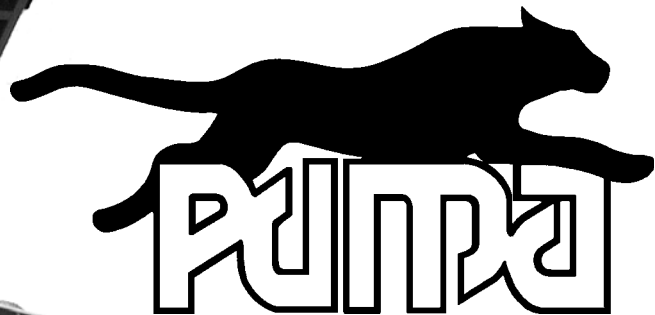

**OPERATOR'S / PARTS  
MANUAL**



***Dump Trailers***  
**Models**

**PUMA-7000**

**PUMA-10000**

VISIT OUR WEBSITE



[www.pronovost.qc.ca](http://www.pronovost.qc.ca)

Copyright © Les Machineries Pronovost Inc., 2003

All rights reserved.  
Printed in Canada.

---

---

# ***TABLE OF CONTENTS***

---

---

<b>Section</b>	<b>Item</b>	<b>Page</b>
<b>1</b>	<b>Introduction .....</b>	<b>5</b>
<b>2</b>	<b>Safety .....</b>	<b>6</b>
	General Safety .....	6
	Safety in Operation .....	6
	Safety with Maintenance .....	7
	Safety in Transport .....	7
	Safety in Storage .....	7
<b>3</b>	<b>Decals .....</b>	<b>8</b>
	Safety Decals .....	8
	Maintenance Decals .....	9
<b>4</b>	<b>Start-up .....</b>	<b>10</b>
	Basic Start-up Procedures .....	10
<b>5</b>	<b>Maintenance .....</b>	<b>11</b>
<b>6</b>	<b>Storage .....</b>	<b>12</b>
<b>7</b>	<b>Specifications .....</b>	<b>13</b>
<b>8</b>	<b>Parts List .....</b>	<b>14</b>
	Dump Trailer PUMA-7000 .....	14
	Dump Trailers PUMA-1000 .....	17
	Electric circuit .....	20
<b>9</b>	<b>Torque Chart .....</b>	<b>21</b>
<b>10</b>	<b>Warranty .....</b>	<b>22</b>



---

---

# INTRODUCTION

---

## CONGRATULATIONS!

Thank you for choosing PRONOVOST. We are confident this equipment will meet your requirements in terms of quality, performance and reliability.

This manual was prepared to assist you in the safe operation of your new Dump Trailer. It contains important information which will help you achieve excellent returns with your PRONOVOST Dump Trailer for years to come.

Please read this manual before operating your Trailer and keep it for future reference.

Before using this equipment, you or any other person who will be using it must familiarize yourself with the safety recommendations, the operating and safety instructions. Please read carefully and be sure to understand and follow all recommendations and procedures.

In this manual, the right and left sides are identified while standing at the rear end of the equipment and facing it.

If you require additional information on your Dump Trailer, please contact your PRONOVOST Dealer.

**NOW** take a moment to enter the model, serial number and the date of purchase of your Trailer in the space provided below.

When ordering parts from your Dealer, please refer to these numbers for a fast and efficient service. Use PRONOVOST parts for replacement.

The model and serial numbers are on the name plate shown on Fig. 1.



Figure 1

MODEL: \_\_\_\_\_ ✍

SERIAL NO: \_\_\_\_\_ ✍

DATE OF PURCHASE: \_\_\_\_\_ ✍

---

---

# ***SAFETY***

---

## **GENERAL SAFETY**

**2**

### **WHEN YOU SEE THIS SYMBOL**



**ATTENTION!**

**BE ALERT  
YOUR SAFETY IS INVOLVED**

This symbol "SAFETY ALERT" is used in this manual and on the safety decals on the Trailer. It warns you of the possibility of danger. Carefully read, understand and follow all safety recommendations before operating the equipment.

- 1) Careful operation is the best assurance against accidents. Carefully read this manual and follow all recommendations before operating this equipment. It is the owner's responsibility to make sure that anyone who will operate the Trailer will read this manual before operating the equipment.
- 2) Do not modify the equipment. Any non authorized modification may affect the efficiency and/or safety of the equipment.
- 3) Never operate the equipment with defective parts or if damaged in any way. Have it repaired before using it.
- 4) Make sure all fasteners are in place and properly secured or tightened. Refer to torque chart on page 21.
- 5) Hydraulic fluids under pressure can damage your skin. Do not use your hands to locate a leak.
- 6) Battery (with 12V hydraulic system) contains

sulfuric acid. Avoid contact with skin, eyes or clothing.

## **SAFETY IN OPERATION**

- 1) **WARNING!** Do not overload your trailer, do not exceed the load capacity indicated in the specifications on page 13.
- 2) Be sure there are no obstructions around the equipment and that no one stands near the equipment when in use.
- 3) Do not operate an engine in a confined or non ventilated area.
- 4) Do not perform any adjustments, cleaning, maintenance or repairs with the engine running on the towing vehicle. Preferably remove the key from the ignition.
- 5) Be careful when backing-up, make sure you have good visibility.
- 6) Make sure the suspension, brakes and lights are all functioning properly.
- 7) Do not forget to unlock the proper panel lock before dumping.
- 8) Always travel at a safe operating speed following regulations and common sense.
- 9) Check battery charge regularly to insure proper functioning of emergency brakes. Ideal charge: 12.66 volts.

---

---

## ***SAFETY (cont'd)***

---

### ***SAFETY WITH MAINTENANCE***

- 1) Perform maintenance according to recommendations contained in this manual.
- 2) **Before performing any work under the raised platform, always install the safety prop provided.**
- 3) If the trailer is hooked up to the vehicle while performing maintenance work, make sure the engine is not running and preferably remove the ignition key.

### ***SAFETY IN TRANSPORT***

- 1) Be alert while driving on the road. Never carry passengers in the trailer.
- 2) It is prohibited to circulate on public roads with rear panel tied off to side of trailer.

**2**

# DECALS

## SAFETY DECALS

The safety decals are affixed wherever special safety precautions are indicated. Locate them on the equipment and read them carefully. If a decal is damaged, lost or illegible, install a new one. The following photos indicate where each one must be installed.

3

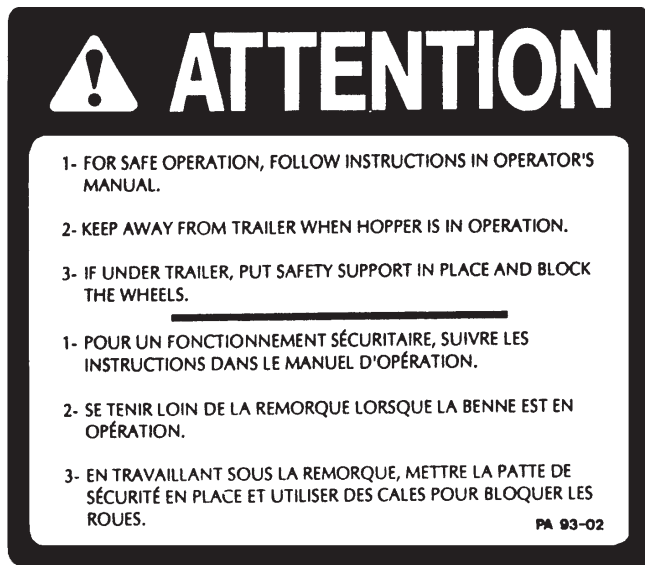

Figure 2  
Decal A

Part no.: A110



Figure 3  
Decal B

Part no.: 190-04731

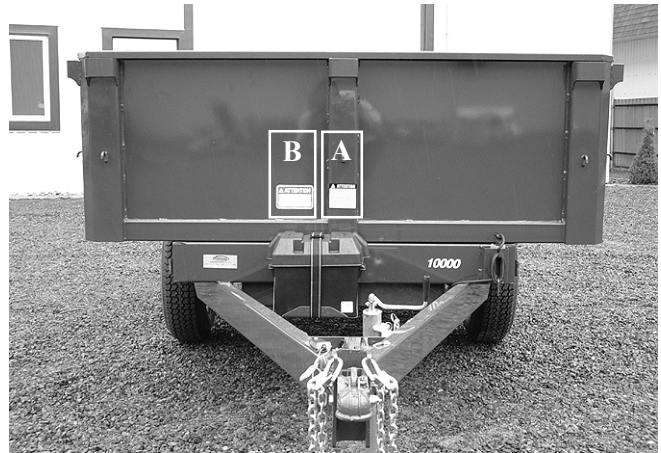

Figure 4



Figure 4  
Decal C

Part no.: 190-04521



Figure 5



---

---

# *DECALS*

---

## *MAINTENANCE DECALS*

The maintenance decals indicate the points requiring lubrication. Refer to maintenance section for more details.



Figure 4

Part no.: A 105

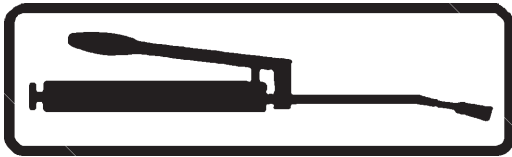

Figure 5

Part no.: A 106

---

---

# ***START-UP***

---

## ***BASIC START-UP PROCEDURES***

- 1) Lubricate all grease fittings with a good quality multiuse grease.
- 2) Lubricate panel release mechanism with good quality oil.
- 3) Adjust tire pressure to manufacturer's specifications.
- 4) Install wheels on hubs.
- 5) Install panels.
- 6) Verify for adequate tightness of all fastening devices. Refer to torque chart on page 21.
- 7) Check oil level in hydraulic reservoir. Use DEXTRON III or equivalent.
- 8) Check battery charge regularly to insure proper functioning of emergency brakes. Ideal charge: 12.66 volts.
- 9) Do not forget to unlock the proper panel lock before dumping.

**4**

---

---

## ***MAINTENANCE***

---

**Before performing any work under the raised platform, always install the safety prop provided.**

- 1) Wipe off all grease fittings with a clean cloth before adding grease in order to avoid injecting dirt or sand.
- 2) Repair or replace damaged grease fittings.
- 3) Lubricate all grease fittings every 20 hours of operation.
- 4) Check all bolts on wheels after first 5 hours of operation and then every 50 hours of operation.
- 5) Lubricate panel release mechanism every 20 hours of operation.
- 6) Check tire pressure every 50 hours of operation, adjust according to recommendation indicated on the tires.
- 7) Check brakes once a year and adjust or repair if necessary.
- 8) Open, clean and lubricate wheel bearings once a year.
- 9) Check all nuts and bolts once a year. If necessary use torque chart on page 21.
- 10) Check oil level in hydraulic reservoir. Use DEXTRON III or equivalent.
- 11) Check battery charge regularly to insure proper functioning of emergency brakes. Ideal charge: 12.66 volts.

---

---

## ***STORAGE***

---

- 1) Store in a cool, dry place.
- 2) Install wooden blocks under the axles to keep the tires off the ground and cover them if left exposed to the sun.
- 3) Keep all piston rods in the retracted position. This will assure better protection against the elements.
- 4) Clean your trailer.
- 5) Thoroughly inspect all parts of the trailer. Replace or repair worn or defective parts.
- 6) Touch-up or repaint if necessary.
- 7) Lubricate all points before storage.

# ***SPECIFICATIONS***

<b>MODEL</b>	<b>PUMA-7000</b>	<b>PUMA-10000</b>
Gross weight	7 000 lbs	10 000 lbs
Interior dimensions of box	72" x 120"	72" x 120"
Front and sides panels (welded)	24" x 14G	24" x 14G
Rear panel (removable)	24" x 14G	24" x 14G
Opening rear panel	swings up or to the side	swings up or to the side
Platform height	31"	32"
Clearance of platform at maximum tilt	17"	18"
Over-all length	176"	176"
Over-all width	79 <sup>15</sup> / <sub>16</sub> "	79 <sup>15</sup> / <sub>16</sub> "
Over-all height (box down)	58"	59"
Over-all height (at maximum tilt)	126"	127"
Tread width c/c	62"	61"
Dumping angle	47°	47°
Suspension	Leaf springs	Leaf springs
Wheels	4	4
Wheels dimensions	14" x 6"	15" x 6"
Tires (standards)	ST205/75D14 (50 psi)	ST225/75D15 (65 psi)
Ball hitch (adjustable height)	Ball 2 <sup>5</sup> / <sub>16</sub> "	Ball 2 <sup>5</sup> / <sub>16</sub> "
Manual jack	3 000 lbs	3 000 lbs
Electric brakes (on 4 wheels)	Standard	Standard
Signal lights (12V)	Standard	Standard
Oil volume required	1.45 gal. / 5.5 litres	1.60 gal. / 6 litres
Cylinder	1 x 4" single action	2 x 3" single action
Break away brake kit	Standard	Standard
12V - Battery	Standard	Standard
Electric hydraulic pump 12V with hand held switch + 6' lead	Standard	Standard
Safety chains	Standard	Standard
App. total weight	1 775 lbs	1 885 lbs

Design and specifications subject to change without notice.

# TRAILER PUMA-7000

170-02903

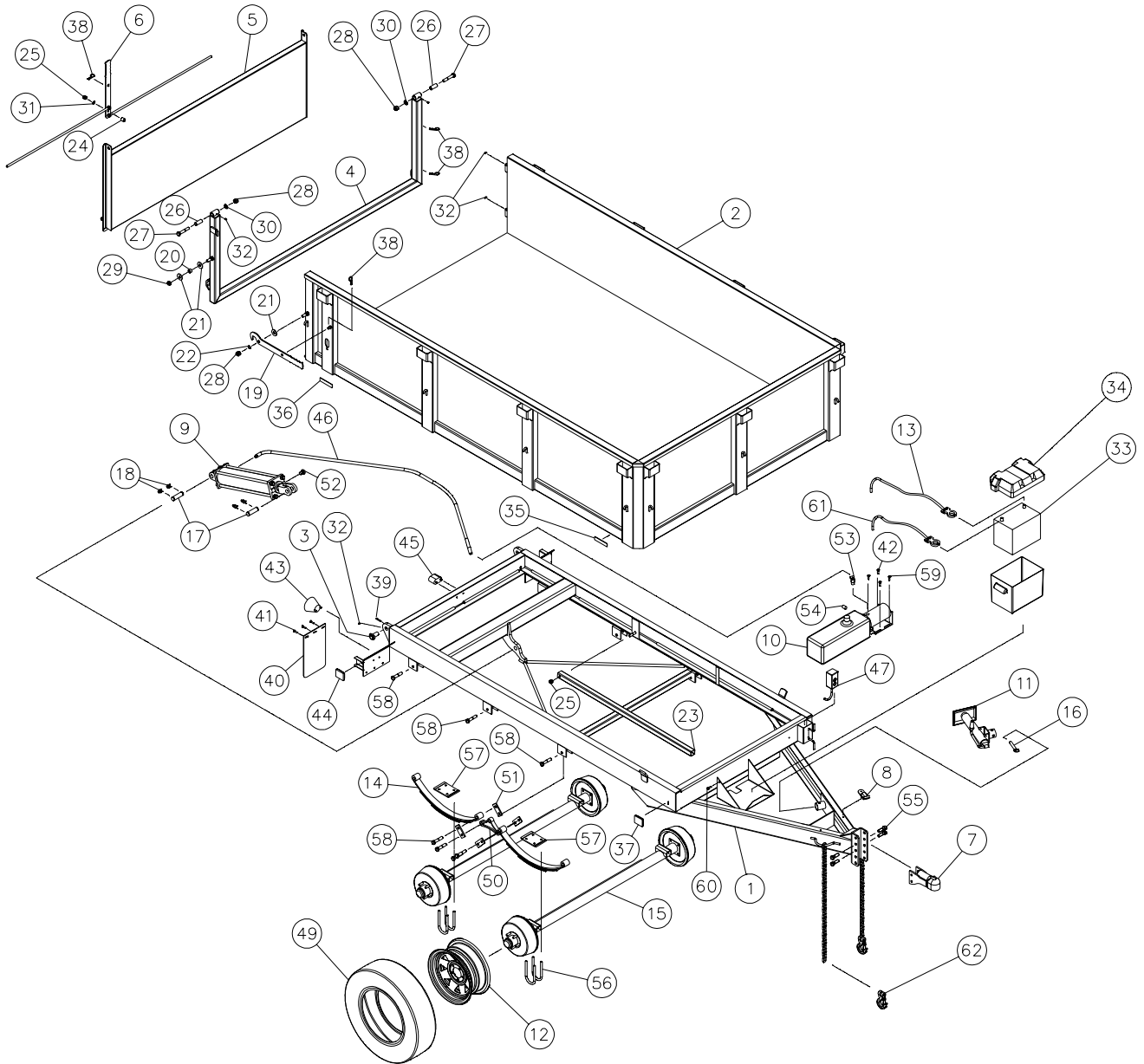

8

## TRAILER PUMA-7000 (cont'd)

REF.	PART #	DESCRIPTION	QTY
1	120-03772	Main frame .....	1
2	120-03732	Dump box .....	1
3	110-16551	Clevis pin .....	2
4	110-16972	Rear panel frame .....	1
5	110-16991	Rear panel .....	1
6	110-16951	Rear panel lock .....	1
7	51615	Ball hitch 2 5/16" .....	1
8	52069	Emergency brake switch .....	1
9	40TR18	Cylinder 4" x 18" (repair kit: CHV3712) .....	1
10	54003	Electric hydraulic pump (at 2000 psi) .....	1
11	54034	Jack 3000 lbs .....	1
12	RM-1465	Rim 14" x 6" - 5 bolts .....	4
13	51606	Battery cable 30" .....	1
14	54010-1	Springs.....	4
15	110-17291	Axle assembly with hubs and brakes .....	2
16	54009	Pin for jack .....	1
17	150-01841	Clevis pin 1" x 3 1/8" .....	2
18	Std.	Hitch pin clip 3/16" .....	4
19	130-20911	Rear panel frame lock .....	1
20	150-03381	Eccentric bushing - rear panel frame lock .....	1
21	376-44000	Flat washer 5/8" .....	3
22	373-44500	5/8" wave washer .....	1
23	160-07921	Safety support .....	1
24	160-07891	Bushing for rear panel locking mechanism .....	1
25	346-40000	Nylon locknut 1/2" NC .....	2
26	160-07831	Spacer for rear panel hinge .....	2
27	300-44430	Bolt 5/8" NC x 3 1/2" .....	2
28	346-44000	Nylon lock nut 5/8" .....	2
29	346-45000	Nylon lock nut (thin) 5/8" .....	1
30	376-45000	Flat washer 5/8" x 0.100" ép.....	2
31	373-42500	9/16" wave washer .....	1
32	Std.	Grease fitting 1/4"-28 straight .....	6
33	51614	Battery 12 Volts 850 Amp. ....	1
34	54002	Plastic battery box .....	1
35	54005	Yellow reflector 1 1/8" x 4 1/2" .....	2
36	54006	Red reflector 1 1/8" x 4 1/2" .....	2
37	52077	Yellow parking light .....	2
38	Std.	Hitch pin 5/32" .....	4
39	Std.	Cotter pin 3/16" x 1 1/2" .....	2
40	51612	Mudguard 8" x 14" .....	2
41	300-32250	Bolt 1/4" NC x 1"+ flat washer + nut .....	6
42	300-34250	Bolt 5/16" NC x 1" + flat washer + nylon locknut .....	3
43	32229	Rear signal light .....	2
44	52076	Red parking light .....	2
45	52070	Light for license plate .....	1
46	190-04421	Hose 3/8" x 102" + 2 fittings 6U 106 .....	1
47	54007	Handheld control for hydraulic electric pump .....	1
49	PN-20575D14	Road tire ST205/75D14 .....	4
50	54011	Spring's pivot .....	2
51	54012	Pivot plates .....	8

---



---

## ***TRAILER PUMA-7000 (cont'd)***

---

<b>REF.</b>	<b>PART #</b>	<b>DESCRIPTION</b>	<b>QTY</b>
52	54004	1/2" NPT vent plug .....	1
53	9355-6x6	Elbow 45 deg. male - female 3/8" .....	1
54	C3159-4	1/4" NPT plug .....	1
55	300-44490	Bolt 5/8" NC x 4 1/2" + nylon locknut .....	2
56	Std.	«U» bolt 1/2" NF x 3" x 7" + 2 nylon locknuts .....	8
57	51599	Spring back plate .....	4
58	300-44400	Bolt 5/8" NC x 3" + nylon locknut .....	14
59	300-34250	Bolt 5/16" NC x 1" + 2 star lockwashers + nylon locknut .....	1
60	300-34250	Bolt 5/16" NC x 1" + star lockwasher + nylon locknut .....	1
61	54071	Battery cable 10" .....	1
62	54070	Hook with safety lock .....	2



# TRAILER PUMA-10000

170-02923

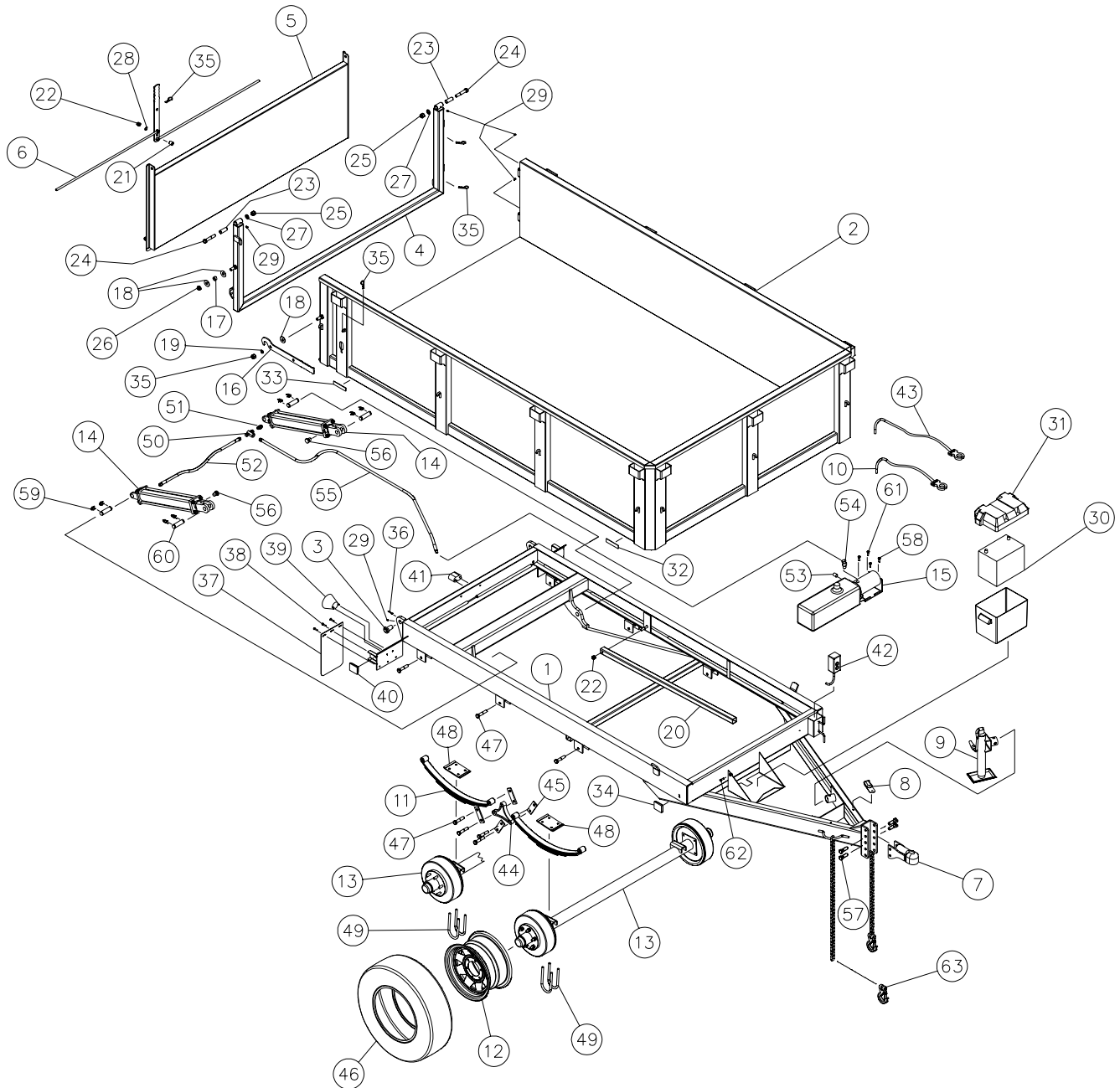

8

## TRAILER PUMA-10000 (cont'd)

REF.	PART #	DESCRIPTION	QTY
1	120-03912	Main frame .....	1
2	120-03902	Dump box .....	1
3	110-16551	Clevis pin .....	2
4	110-16972	Rear panel frame .....	1
5	110-16991	Rear panel .....	1
6	110-16951	Rear panel lock .....	1
7	51615	Ball hitch 2 5/16" .....	1
8	52069	Emergency brake switch .....	1
9	54034	Jack 3000 lbs .....	1
10	54071	Battery cable 10" .....	1
11	51600	Springs .....	4
12	RM-1666	Rim 15" x 6" - 6 bolts .....	4
13	110-19101	Axle assembly with hubs and brakes .....	2
14	30TR18	Cylinder 3" x 18" (repair kit: CHV3708) .....	2
15	54003	Electric hydraulic pump (at 2,500 psi) .....	1
16	130-20911	Rear panel frame lock .....	1
17	150-03381	Eccentric bushing - rear panel frame lock .....	1
18	376-44000	Flat washer 5/8" .....	3
19	373-44500	Wave washer 5/8" .....	1
20	160-07921	Safety support .....	1
21	160-07891	Bushing for rear panel locking mechanism .....	1
22	346-40000	Nylon locknut 1/2"NC .....	2
23	160-07831	Spacer for rear panel hinge .....	2
24	300-44430	Bolt 5/8" NC x 3 1/2" .....	2
25	346-44000	Nylon locknut 5/8" .....	2
26	346-45000	Nylon locknut (thin) 5/8" .....	1
27	376-45000	Flat washer 5/8" x 0.100" ép. ....	2
28	373-42500	Wave washer 9/16" .....	1
29	Std.	Grease fitting 1/4"-28 straight .....	6
30	51614	Battery 12 Volts 850 Amp. ....	1
31	54002	Plastic battery box .....	1
32	54005	Yellow reflector 1 1/8" x 4 1/2" .....	2
33	54006	Red reflector 1 1/8" x 4 1/2" .....	2
34	52077	Yellow parking light .....	2
35	Std.	Hitch pin 5/32" .....	4
36	Std.	Cotter pin 3/16" x 1 1/2" .....	2
37	51612	Mudguard 8" x 14" .....	2
38	300-32250	Bolt 1/4" NC x 1" + flat washer + nut .....	6
39	32229	Rear signal light .....	2
40	52076	Red parking light .....	2
41	52070	Light for license plate .....	1
42	54007	Hand held control for hydraulic electric pump .....	1
43	51606	Battery cable 30" .....	1
44	51483	Spring's pivot .....	2
45	51601	Pivot plates .....	8
46	PN-22575D15	Road tire ST225/75D15 .....	4
47	300-44400	Bolts 5/8" NC x 3" + nylon locknut .....	14
48	51599	Spring back plate .....	4
49	Std.	«U» bolts 1/2" NF x 3" x 7" + 2 nylon locknuts .....	8
50	5856-8x8x8	«T» fitting .....	1

## ***TRAILER PUMA-10000 (cont'd)***

<b>REF.</b>	<b>PART #</b>	<b>DESCRIPTION</b>	<b>QTY</b>
51	3069-8x8	Fitting .....	1
52	190-04431	Hose 3/8" x 25 3/4" + 2 fittings 6U 108 .....	1
53	C3159-4	Plug 1/4" NPT .....	1
54	9355-6x6	Elbow 45 deg. male - female 3/8" .....	1
55	190-04441	Hose 3/8" x 93" + 1 fitting 6U 106 + 1 fitting 6U 108 .....	1
56	54004	Vent plug 1/2" NPT .....	2
57	300-44430	Bolt 5/8" NC x 4 1/2" + nylon locknut .....	2
58	300-34250	Bolt 5/16" NC x 1" + flat washer + nylon locknut .....	3
59	Std.	Hitch pin clip 3/16" .....	8
60	150-01841	Clevis pin 1" x 3 1/8" .....	4
61	300-34250	Bolt 5/16" NC x 1" + 2 star lockwashers + nylon locknut .....	1
62	300-34250	Bolt 5/16" NC x 1" + star lockwasher + nylon locknut .....	1
63	54070	Hook with safety lock .....	2

# ELECTRIC CIRCUIT PUMA-7000 & PUMA-10000

170-02931

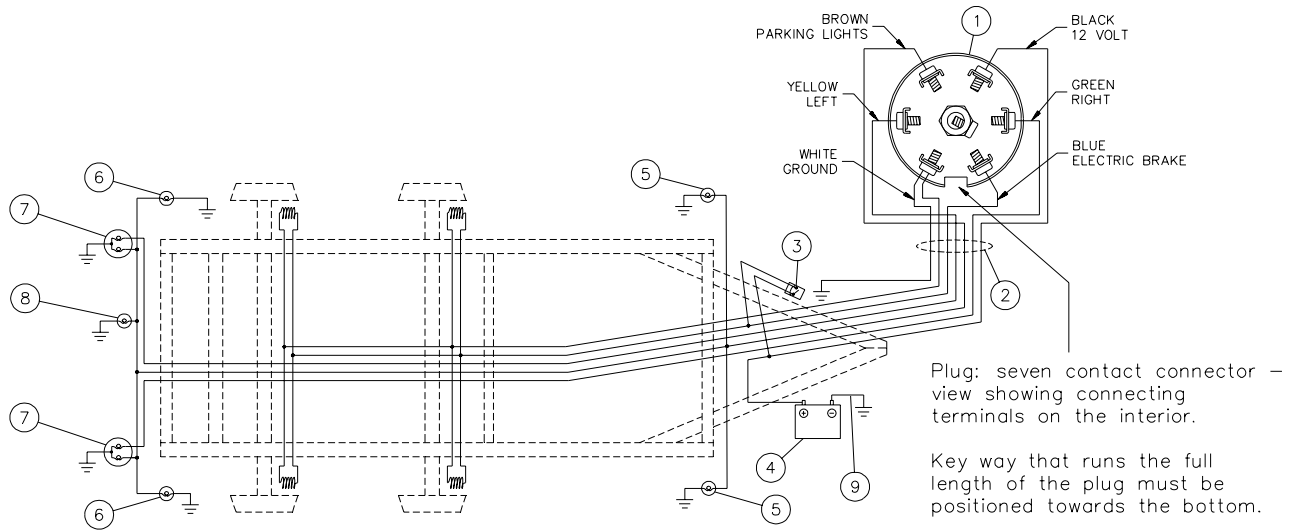







REF.	PART #	DESCRIPTION	QTY
1	52065	Connector 7 poles (female) .....	1
2	54013	PUMA conductor cable kit .....	1
3	52069	Emergency brake switch .....	1
4	51614	Battery 12 volts 850 Amp .....	1
5	52077	Yellow parking light .....	2
6	52076	Red parking light .....	2
7	32229	Flasher .....	2
8	52070	License plate .....	1
9	51607	Battery cable 4 GA. x 10" Lg. ....	1





8

# TORQUE CHART

## TORQUE SPECIFICATION TABLE

Thread UNC and UNF		Grade 2 				Grade 5   				Grade 8*   			
Bolt size		Torque				Torque				Torque			
Inches	mm	Pound feet min.	max.	Newton meters min.	max.	Pound feet min.	max.	Newton meters min.	max.	Pound feet min.	max.	Newton meters min.	max.
1/4	6.35	5	6	6.8	8.13	9	11	12.2	14.9	12	15	16.3	30.3
5/16	7.94	10	12	13.6	16.3	17	20.5	23.1	27.8	24	29	32.5	39.3
3/8	9.53	20	23	27.1	31.2	35	42	47.5	57.0	45	54	61.0	73.2
7/16	11.11	30	35	40.7	47.4	54	64	73.2	86.8	70	84	94.9	113.9
1/2	12.70	45	52	61.0	70.5	80	96	108.5	130.2	110	132	149.2	179.0
9/16	14.29	65	75	88.1	101.6	110	132	149.2	179.0	160	192	217.0	260.4
5/8	15.88	95	105	128.7	142.3	150	180	203.4	244.1	220	264	298.3	358.0
3/4	19.05	150	185	203.3	250.7	270	324	366.1	439.3	380	456	515.3	618.3
7/8	22.23	160	200	216.8	271.0	400	480	542.4	650.9	600	720	813.6	976.3
1	25.40	250	300	338.8	406.5	580	696	786.5	943.8	900	1080	1220.4	1464.5
1 1/8	25.58	-	-	-	-	800	880	1084.8	1193.3	1280	1440	1735.7	1952.6
1 1/4	31.75	-	-	-	-	1120	1240	1518.7	1681.4	1820	2000	2467.9	2712.0
1 3/8	34.93	-	-	-	-	1460	1680	1979.8	2278.1	2380	2720	3227.3	3688.3
1 1/2	38.10	-	-	-	-	1940	2200	2630.6	2983.2	3160	3560	4285.0	4827.4

\* Thick nuts must be used with grade 8 bolts.

Size of screw	Thread	Pitch (mm)	Grade 4T  				Grade 7T 				Grade 8T  			
			Torque				Torque				Torque			
			Pound feet min.	max.	Newton meters min.	max.	Pound feet min.	max.	Newton meters min.	max.	Pound feet min.	max.	Newton meters min.	max.
M6	UNC	1.00	3.6	5.8	4.9	7.9	5.8	9.4	7.9	12.7	7.2	10	9.8	13.6
M8	UNC	1.25	7.2	14	9.8	19	17	22	23	29.8	20	26	27.1	35.2
M10	UNC	1.5	20	25	27.1	33.9	34	40	46.1	54.2	38	46	51.5	62.3
M12	UNC	1.75	28	34	37.9	46.1	51	59	69.1	79.9	57	66	77.2	89.4
M14	UNC	2.0	49	56	66.4	75.9	81	93	109.8	126	96	109	130.1	147.7
M16	UNC	2.0	67	77	90.8	104.3	116	130	157.2	176.2	129	145	174.8	196.5
M18	UNC	2.0	88	100	119.2	136	150	168	203.3	227.6	175	194	237.1	262.9
M20	UNC	2.5	108	130	146.3	176.2	186	205	252	277.8	213	249	288.6	337.4
M8	UNF	1.0	12	17	16.3	23	19	27	25.7	36.6	22	31	29.8	42
M10	UNF	1.25	20	29	27.1	39.3	35	47	47.4	63.7	40	52	54.2	70.5
M12	UNF	1.25	31	41	42	55.6	56	68	75.9	92.1	62	75	84	101.6
M14	UNF	1.5	52	64	70.5	86.7	90	106	122	143.6	107	124	145	168
M16	UNF	1.5	69	83	93.5	112.5	120	138	162.6	187	140	158	189.7	214.1
M18	UNF	1.5	100	117	136	158.5	177	199	239.8	269.6	202	231	273.7	313
M20	UNF	1.5	132	150	178.9	203.3	206	242	279.1	327.9	246	289	333.3	391.6

Use the above torques when special torque is not given.

NOTE: These values apply to fasteners as received from supplier, dry, or when lubricated with normal engine oil. They do not apply if extreme pressure lubricants are used.

---

---

## *WARRANTY*

---

PRONOVOST warrants this product to the initial purchaser for the period of one year from the date of purchase against defects in materials and workmanship.

We will replace or repair defective parts free of charge if they are returned to our plant in St-Tite, Quebec, Canada.

Transportation charges are the responsibility of the customer. This warranty is not transferable.

Hydraulic cylinders are covered by the manufacturer of these items.

All PRONOVOST spare parts purchased are covered by a three (3) month warranty.

This warranty becomes void and nul if the equipment is modified, breaks down as the result of an accident, is not operated according to manufacturer's recommendations, damaged by negligence or if maintenance has not been carried out as specified.

Our obligation is limited to the replacement or repair of the defective part. PRONOVOST accepts no responsibility for direct or indirect consequential damages of any kind.



Ce manuel est aussi disponible en français.  
Veuillez téléphoner.



**INNOVATION - EXCELLENCE**

**LES MACHINERIES PRONOVOST INC.**

260, route 159,

Saint-Tite, Quebec, Canada, G0X 3H0

Tel.: (418) 365-7551, Fax: (418) 365-7954

[www.pronovost.qc.ca](http://www.pronovost.qc.ca)