



**OPERATOR'S / PARTS  
MANUAL**



***Dump Trailers***  
**Models**

**P-516**



Copyright © Les Machineries Pronovost Inc., 2001

All rights reserved.  
Printed in Canada.

---

---

# ***TABLE OF CONTENTS***

---

---

<b>Section</b>	<b>Item</b>	<b>Page</b>
<b>1</b>	<b>Introduction .....</b>	<b>5</b>
<b>2</b>	<b>Safety .....</b>	<b>6</b>
	General Safety .....	6
	Safety in Operation .....	6
	Safety with Maintenance .....	7
	Safety in Transport .....	7
	Safety in Storage .....	7
<b>3</b>	<b>Decals .....</b>	<b>8</b>
	Safety Decals .....	8
	Maintenance Decals .....	8
<b>4</b>	<b>Start-up .....</b>	<b>9</b>
	Basic Start-up Procedures .....	9
<b>5</b>	<b>Maintenance .....</b>	<b>10</b>
<b>6</b>	<b>Storage .....</b>	<b>11</b>
<b>7</b>	<b>Specifications .....</b>	<b>12</b>
<b>8</b>	<b>Parts List .....</b>	<b>13</b>
	Dump Trailers P-516 .....	13
	Hub H5000 .....	15
	Cylinder 30BS28 .....	16
	Jack #51459 .....	17
<b>9</b>	<b>Torque Chart .....</b>	<b>18</b>
<b>10</b>	<b>Warranty .....</b>	<b>19</b>



---

---

# INTRODUCTION

---

## CONGRATULATIONS!

Thank you for choosing PRONOVOST. We are confident this equipment will meet your requirements in terms of quality, performance and reliability.

This manual was prepared to assist you in the safe operation of your new Dump Trailer. It contains important information which will help you achieve excellent returns with your PRONOVOST Dump Trailer for years to come.

Please read this manual before operating your Trailer and keep it for future reference.

Before using this equipment, you or any other person who will be using it must familiarize yourself with the safety recommendations, the operating and safety instructions. Please read carefully and be sure to understand and follow all recommendations and procedures.

In this manual, the right and left sides are identified while standing at the rear end of the equipment and facing it.

If you require additional information on your Dump Trailer, please contact your PRONOVOST Dealer.

**NOW** take a moment to enter the model, serial number and the date of purchase of your Trailer in the space provided below.

When ordering parts from your Dealer, please refer to these numbers for a fast and efficient service. Use PRONOVOST parts for replacement.

The model and serial numbers are on the name plate shown on Fig. 1.



Figure 1

MODEL: \_\_\_\_\_ ✍

SERIAL NO: \_\_\_\_\_ ✍

DATE OF PURCHASE: \_\_\_\_\_ ✍

---

---

# ***SAFETY***

---

## ***GENERAL SAFETY***

**2**

### **WHEN YOU SEE THIS SYMBOL**



**ATTENTION!**

**BE ALERT  
YOUR SAFETY IS INVOLVED**

This symbol "**SAFETY ALERT**" is used in this manual and on the safety decals on the Trailer. It warns you of the possibility of danger. Carefully read, understand and follow all safety recommendations before operating the equipment.

- 1) Careful operation is the best assurance against accidents. Carefully read this manual and follow all recommendations before operating this equipment. It is the owner's responsibility to make sure that anyone who will operate the Trailer will read this manual before operating the equipment.
- 2) Do not modify the equipment. Any non authorized modification may affect the efficiency and/or safety of the equipment.
- 3) Never operate the equipment with defective parts or if damaged in any way. Have it repaired before using it.
- 4) Make sure all fasteners are in place and properly secured or tightened. Refer to torque chart on page 18.

- 5) Hydraulic fluids under pressure can damage your skin. Do not use your hands to locate a leak.

### ***SAFETY IN OPERATION***

- 1) **WARNING!** Do not overload your trailer, do not exceed the load capacity indicated in the specifications on page 12.
- 2) Be sure there are no obstructions around the equipment and that no one stands near the equipment when in use.
- 3) Do not operate an engine in a confined or non ventilated area.
- 4) Do not perform any adjustments, cleaning, maintenance or repairs with the engine running on the towing vehicle. Preferably remove the key from the ignition.
- 5) Be careful when backing-up, make sure you have good visibility.
- 6) Do not forget to unlock the proper panel before dumping.
- 7) Always travel at a safe operating speed following regulations and common sense. In the case of agricultural service tires, follow the manufacturer's specified safe speed. The road speed should be such as to maintain full control over steering and braking.

---

---

## ***SAFETY (cont'd)***

---

### ***SAFETY WITH MAINTENANCE***

- 1) Perform maintenance according to recommendations contained in this manual.
- 2) **Before performing any work under the raised platform, always install the safety support provided.**
- 3) If the trailer is hooked up to the tractor while performing maintenance work, make sure the engine is not running and preferably remove the ignition key.

- 2) Be alert while driving on the road. Never carry passengers.

**2**

### ***SAFETY IN TRANSPORT***

- 1) On public roads, use proper safety lights and check local regulations.

---

---

# DECALS

---

## SAFETY DECALS

The safety decals are affixed wherever special safety precautions are indicated. Locate them on the equipment and read them carefully. If a decal is damaged, lost or illegible, install a new one. The following photos indicate where each one must be installed.

**3**

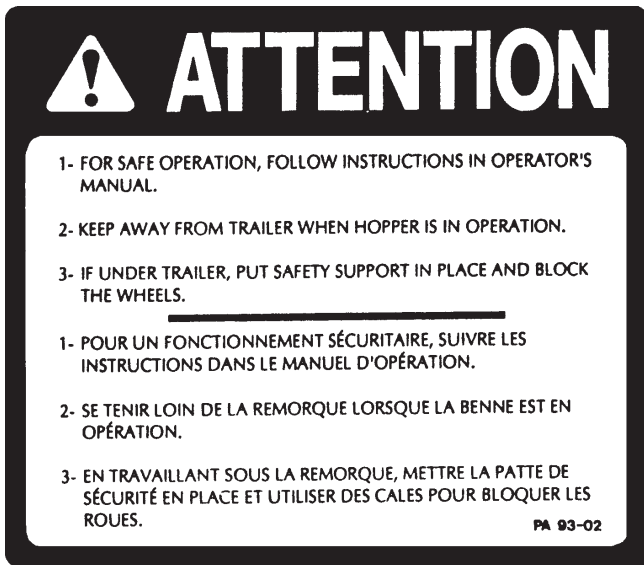

Figure 2  
Decal A

Part no.: A110

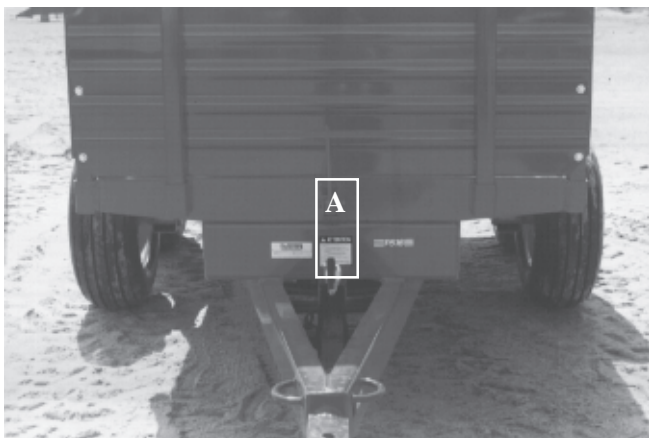

Figure 3

## MAINTENANCE DECALS

The maintenance decals indicate the points requiring lubrication. Refer to maintenance section for more details.

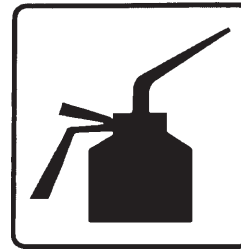

Figure 4

Part no.: A 105



Figure 5

Part no.: A 106



---

---

# ***START-UP***

---

## ***BASIC START-UP PROCEDURES***

- 1) Lubricate all grease fittings with a good quality multiuse grease.
- 2) Lubricate panel release mechanism, front and rear with good quality oil.
- 3) Adjust tire pressure to manufacturer's specifications.
- 4) Install wheels on hubs.
- 5) Install panels.
- 6) Install all hydraulic hoses and fittings compatible with your equipment.
- 7) Verify for adequate tightness of all fastening devices. Refer to torque chart on page 18.
- 8) Operate the hydraulic system a few times, raising and lowering the platform in order to remove any trapped air in the system. Then check the oil level in the tractor's hydraulic oil reservoir.
- 9) Do not forget to unlock the proper panel before dumping.

**4**

---

---

# ***MAINTENANCE***

---

**Before performing any work under the raised platform, always install the safety support provided.**

- 1) Wipe off all grease fittings with a clean cloth before adding grease in order to avoid injecting dirt or sand.
- 2) Repair or replace damaged grease fittings.
- 3) Lubricate all grease fittings every 20 hours of operation.
- 4) Check all bolts on wheels after first 5 hours of operation and then every 50 hours of operation.
- 5) Lubricate panel release mechanism, front and rear, every 20 hours of operation.
- 6) Check tire pressure every 50 hours of operation, adjust according to manufacturer's recommendation indicated on the tires.
- 7) Open, clean and lubricate wheel bearings once a year.
- 8) Check all nuts and bolts once a year. If necessary use torque chart on page 18.

**5**

---

---

## ***STORAGE***

---

- 1) Store in a cool, dry place.
- 2) Install wooden blocks under the axles to keep the tires off the ground and cover them if left exposed to the sun.
- 3) Keep all piston rods in the retracted position. This will assure better protection against the elements.
- 4) Clean your trailer.
- 5) Thoroughly inspect all parts of the trailer. Replace or repair worn or defective parts.
- 6) Touch-up or repaint if necessary.
- 7) Lubricate all points before storage.

# SPECIFICATIONS

SERVICE	AGRICULTURAL
MODEL	P-516
Gross weight	1600 lbs / 7264 kg
Width x length Interior of box po/mm	56" x 118" / 1422 x 2997
Thickness of floor in/mm	3/16" / 4.78 mm
Height: side panel 12G*	16" / 406 mm
Height: front/back panel 12G*	24" / 610 mm
Platform height	32" / 813 mm
Overall length	174" / 3734 mm
Overall width	89" / 2261 mm
Overall height	62" / 1575 mm
Free height / maximum lift	15" / 381 mm
Thread width	74" / 1880 mm
Dumping angle (back)	47°
Dumping angle (2 sides)	--
Central unloading hatch	Optional
Axle	Tandem
Suspension	--
Hubs	6 bolts
Hub capacity	5000 lbs / 2270 kg
Spindles	2" / 51 mm
Wheels	4
Wheel dimensions	15 x 8 x 6
Tires (standard)	11L15 (8 ply)
Hitch: clevis/swivel	standard
Hitch: ball coupler 2 5/16" / 59 mm	--
Electric brakes	--
Safety chain	--
Electric hydraulic pump	--
Battery (12V)	--
Light system (12 V)	--
Oil / volume required	--
Cylinder	2 double acting
Hitch weight (empty)	260 lbs / 118 kg
Total weight	1980 lbs / 900 kg

Design and specifications subject to change without notice.

# DUMP TRAILERS P-516

170-01765

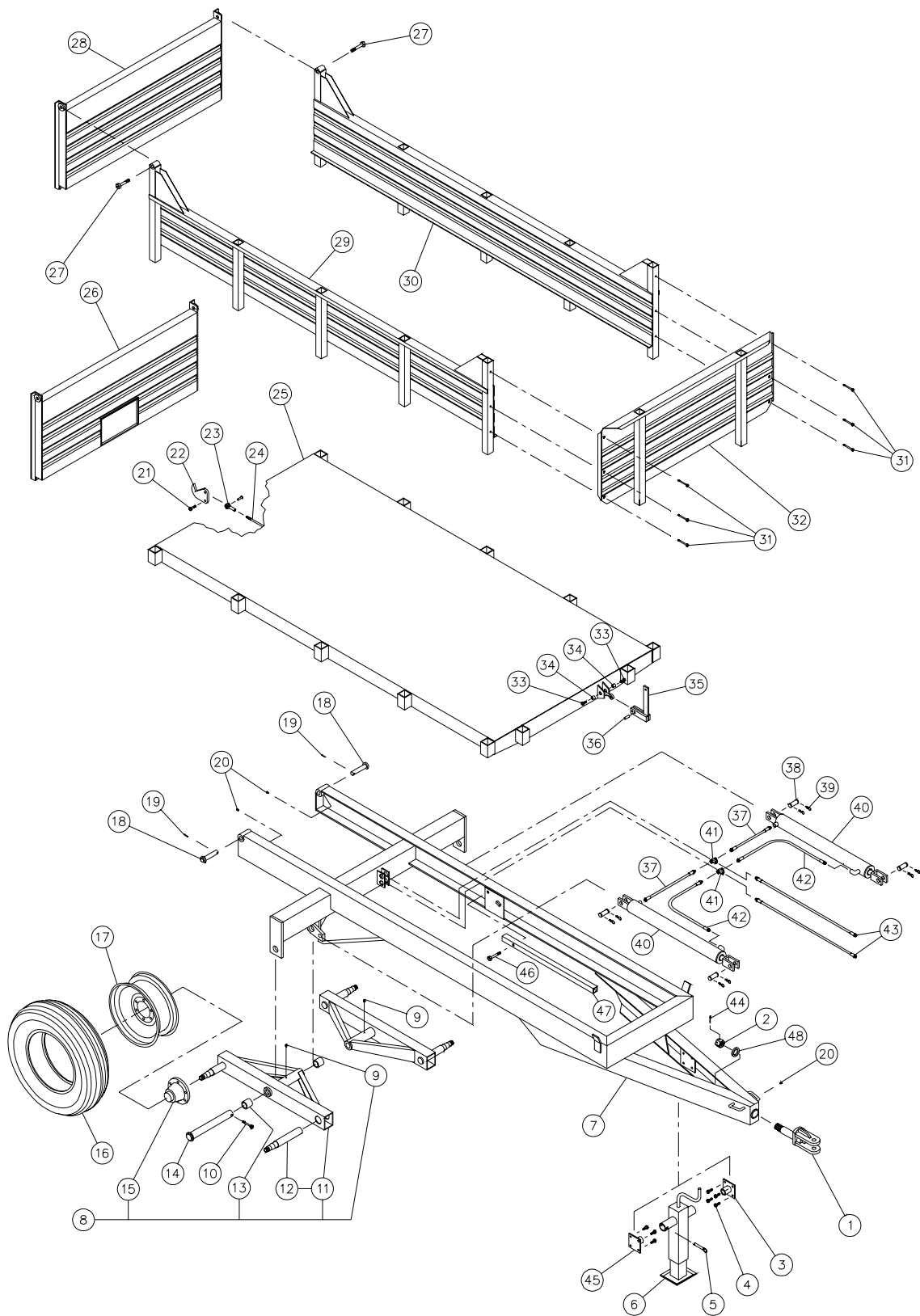

8

# DUMP TRAILERS P-516 (cont'd)

REF.	PART #	DESCRIPTION	QTY
1	110-06901	Swivel hitch .....	1
2	Std.	Castle nut 1 1/2" NC .....	1
3	110-00051	Jack fixation plate (left side) .....	1
4	Std.	Bolt 7/16" NC x 1 1/4" lg + nylon locknut .....	8
5	110-00181	Pin for jack .....	1
6	110-14841	Jack PC-3012L (see details page 17) .....	1
7	120-02241	Frame .....	1
8	110-11403	Tandem assembly .....	2
9	Std.	Grease fitting 1/4"-28 90° .....	2
10	Std.	Bolt 1/2" NC x 3" lg + nut & lock washer .....	2
11	110-11401	Tandem frame .....	2
12	150-02271	Spindle 2" ø (welded) 15" lg .....	4
13	160-01091	Brass bushing 1 3/4" i.d. x 2" o.d. x 2" lg .....	4
14	110-00011	Tandem clevis pin .....	2
15	51441	Hub # H-5000 complete (see details page 15) .....	4
16	PN-11L15	Tire 11L15 - 8 ply with tube .....	4
16	PN-12.5L15	Tire 12.5L15 - 10 ply with tube (4) .....	opt.
17	R-1586	Rim 15" x 8" - 6 holes .....	4
17	R-15106	Rim 15" x 10" - 6 holes (4) .....	opt.
18	110-08971	Clevis pin 1" ø .....	2
19	Std.	Cotter pin 1/4" x 2" lg .....	2
20	Std.	Grease fitting 1/4"-28 straight .....	3
21	Std.	Bolt 1/2" NC x 2" lg + nylon locknut .....	1
22	130-09991	Rear panel lock .....	1
23	51435	Clevis yoke 1/2" NF + nut 1/2" NF + clevis pin 1/2" ø x 1 3/4" lg & cotter pin 1/8" x 3/4" lg .....	1
24	110-12232	Rod 1/2" for rear panel lock .....	1
25	120-02272	Platform .....	1
26	110-02741	Rear panel with grain door (24" height) .....	opt.
27	Std.	Bolt 3/4" NC x 4 1/2" lg + nylon locknut .....	2
28	110-02781	Standard rear panel .....	1
29	110-02721	Right panel (16" height) .....	1
30	110-02731	Left panel (16" height) .....	1
31	Std.	Bolt 3/8" NC x 3" lg + nylon locknut & flat washer .....	6
32	110-12221	Front panel .....	1
33	Std.	Bolt 1/2" NC x 1" lg + lock washer .....	2
34	160-04731	Spacer 33/64" i.d. x 27/32" o.d. x 1/2" lg .....	2
35	110-08981	Lever for rear panel locking mechanism .....	1
36	150-01831	Pin 1/2" x 1 1/4" lg .....	1
37	190-03241	Hose 3/8" x 16 1/4" lg + 2 fittings 6U-106 (from serial # 6334 and up) .....	2
38	51421	Clevis pin 1" ø .....	4
39	51472	Hitch pin clip (CP132H) .....	8
40	30BC28	Cylinder 3" ø x 28" run (from serial # 6334 and up) (see details page 16) .....	2
41	5856-6	"T" 3/8" swivel (from serial # 6334 and up) .....	2
42	190-03261	Hose 3/8" x 40" lg + 2 fittings 6U-106 (from serial # 6334 and up) .....	2
43	190-03251	Hose 3/8" x 161" lg + 1 fitting 6U-106 & 1 fitting 6U-108 (from serial # 6334 and up) .....	2
44	Std.	Cotter pin 1/4" x 3" .....	1
45	110-00061	Jack fixation plate (right side) .....	1
46	Std.	Bolt 5/8" NC x 3" lg + nylon locknut .....	1
47	160-05961	Safety support .....	1
48	130-20401	Ring 1 5/8" i.d. x 2 3/8" o.d. .....	1

# HUB H5000

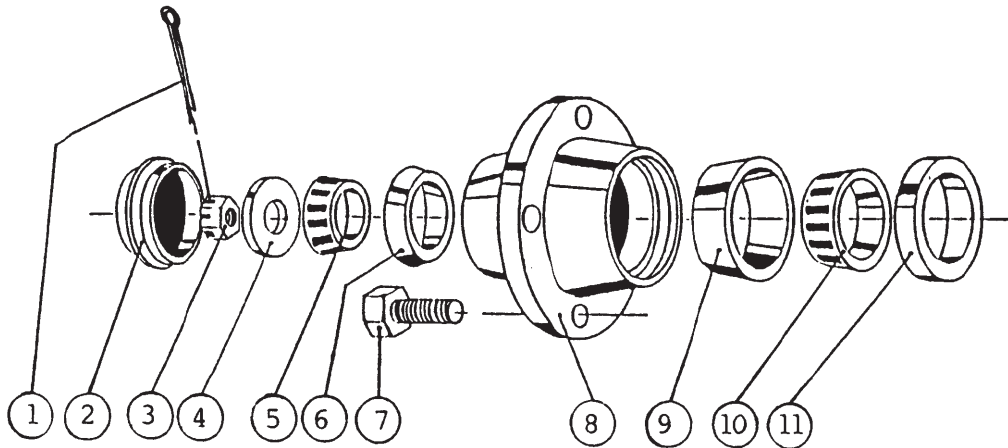

REF.	PART #	DESCRIPTION	QTY
1	Std.	Cotter pin 5/32" x 1 1/2" .....	1
2	51417	Dust cap 2.570" ø .....	1
3	51442	Castle nut 7/8" NF .....	1
4	Std.	Flat washer 7/8" .....	1
5	51416	Roller bearing Timken: cone no. 4T-LM48548 .....	1
6	51415	Roller bearing Timken: cup no. 4T-LM48510 .....	1
7	51418	Rim screw 9/16" .....	6
8	51414	Hub only H5000 .....	1
9	51413	Roller bearing Timken: cup no. 4T-LM603011 .....	1
10	51412	Roller bearing Timken: cone no. 4T-LM603049 .....	1
11	51443	Oil seal no. CR20044 .....	1

# CYLINDER 30BS28 & 30BC28 (30BC28 shown)

170-01911

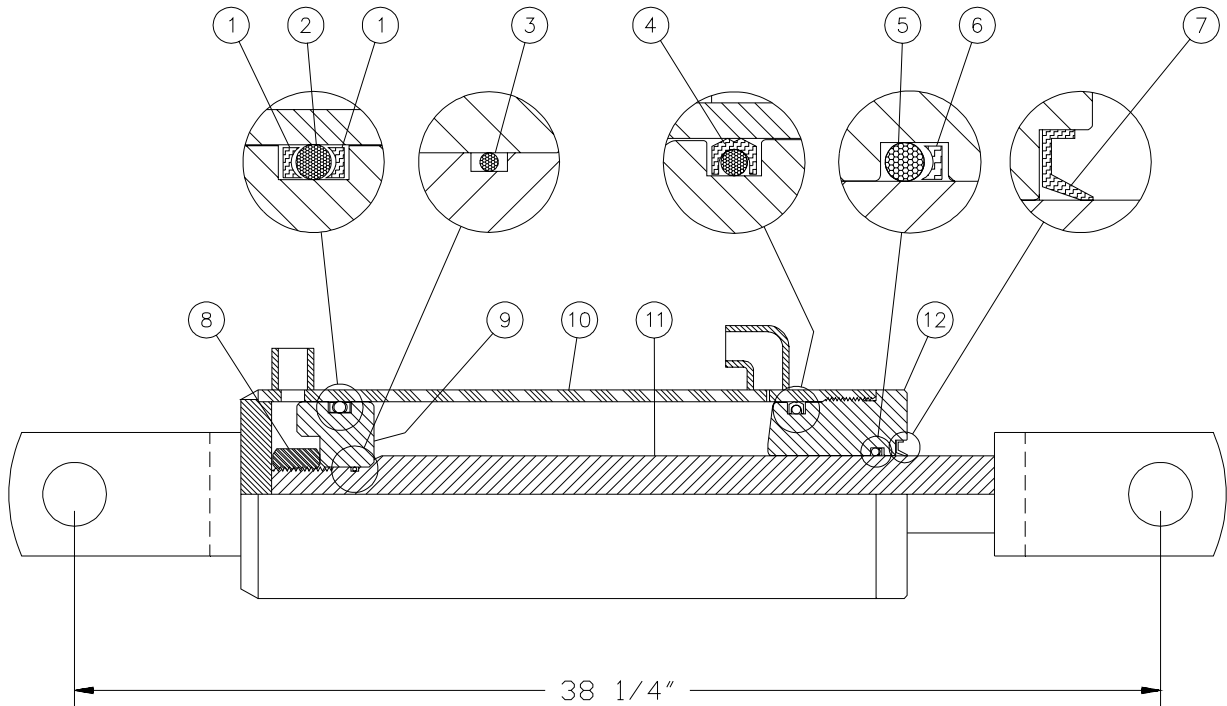

REF.	PART #	DESCRIPTION	QTY	
			30BS28	30BC28
1	BU-334	Back-up 3/16" x 2 5/8" x 3" .....	2	2
2	OR-334	O-ring 3/16" x 2 5/8" x 3" .....	1	1
3	OR-018	O-ring 1/16" x 3/4" x 7/8" .....	1	1
4	PSP-334	O-ring 3/16" x 2 5/8" x 3" .....	1	1
5	OR-218	O-ring 1/8" x 1 1/4" x 1 1/2" .....	1	1
6	BU-218	Back-up 1/8" x 1 1/4" x 1 1/2" .....	1	1
7	CR12330	Wiper 1/8" x 1 1/4" x 1 1/2" .....	1	1
8	Std.	Nut 7/8" NF .....	1	1
9	150-02371	Piston 3" dia. ....	1	1
10	110-11631	Cylinder body 3" for 30BS28 with 2 fittings 1/2" NPT straight (up to serial # 6333) .....	1	-
10	110-12161	Cylinder body 3" for 30BC28 with 1 fitting 3/8" NPT straight & 1 fitting 3/8" NPT 90 deg. (from serial # 6334 and up) .....	-	1
11	110-11641	Piston rod 1 1/4" for 30BS28 & 30BC28 .....	1	1
12	150-02381	Head 3" dia. ....	1	1

8



# JACK PC-3012L # 110-14841

110-14841

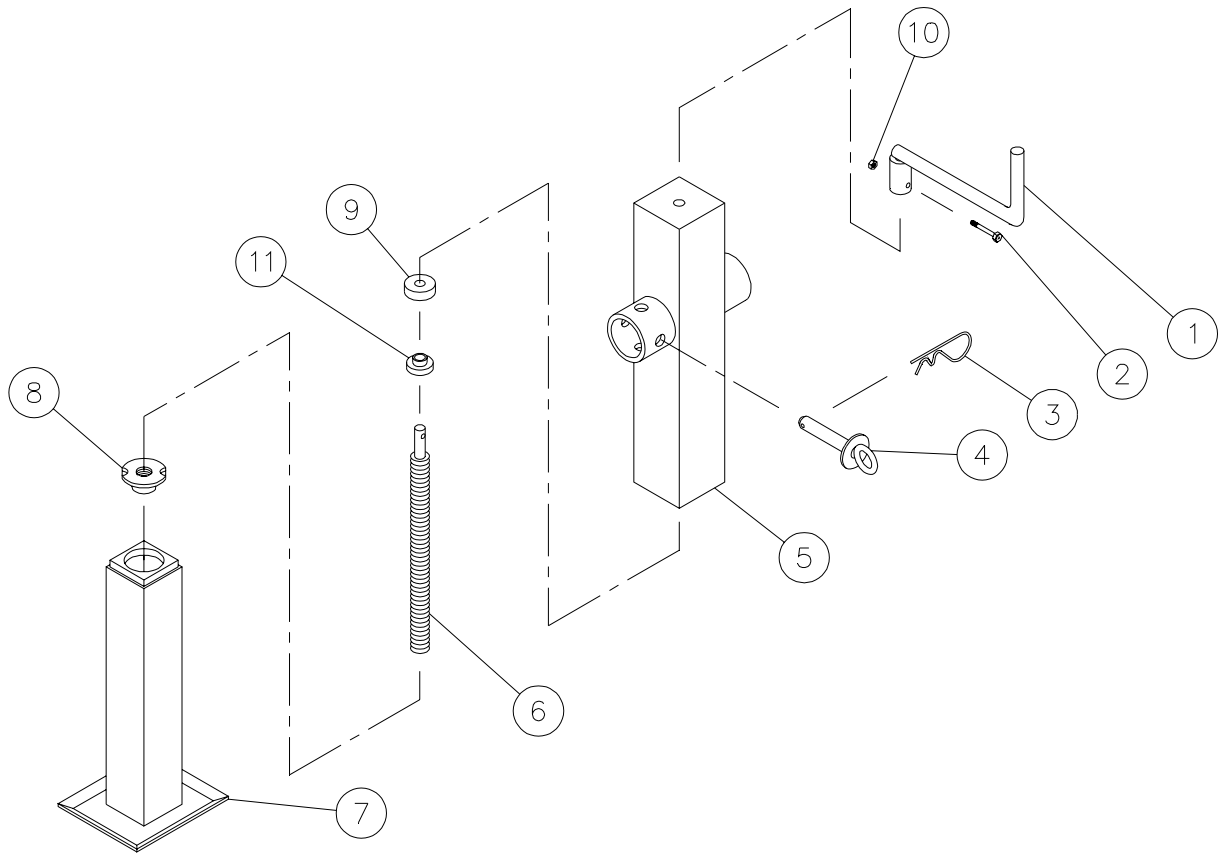







REF.	PART #	DESCRIPTION	QTY
1	110-14411	Hand crank .....	1
2	Std.	Bolt 1/4" NC x 1 1/2" lg + nylon locknut .....	1
3	Std.	Hitch pin clip 5/32" .....	1
4	110-00181	Pin 5/8" x 3 1/2" .....	1
5	110-00081	Jack external part .....	1
6	150-00091	Acme screw 7/8"-8 x 13" lg .....	1
7	110-00031	Jack support .....	1
8	160-00111	Acme nut 7/8"-8 x 1" lg (brass) .....	1
9	51475	Ball bearing .....	1
10	150-00121	Ball bearing support .....	1





**8**

# TORQUE CHART

## TORQUE SPECIFICATION TABLE

Thread UNC and UNF		Grade 2 				Grade 5   				Grade 8*   			
Bolt size		Torque				Torque				Torque			
Inches	mm	Pound feet		Newton meters		Pound feet		Newton meters		Pound feet		Newton meters	
		min.	max.	min.	max.	min.	max.	min.	max.	min.	max.	min.	max.
1/4	6.35	5	6	6.8	8.13	9	11	12.2	14.9	12	15	16.3	30.3
5/16	7.94	10	12	13.6	16.3	17	20.5	23.1	27.8	24	29	32.5	39.3
3/8	9.53	20	23	27.1	31.2	35	42	47.5	57.0	45	54	61.0	73.2
7/16	11.11	30	35	40.7	47.4	54	64	73.2	86.8	70	84	94.9	113.9
1/2	12.70	45	52	61.0	70.5	80	96	108.5	130.2	110	132	149.2	179.0
9/16	14.29	65	75	88.1	101.6	110	132	149.2	179.0	160	192	217.0	260.4
5/8	15.88	95	105	128.7	142.3	150	180	203.4	244.1	220	264	298.3	358.0
3/4	19.05	150	185	203.3	250.7	270	324	366.1	439.3	380	456	515.3	618.3
7/8	22.23	160	200	216.8	271.0	400	480	542.4	650.9	600	720	813.6	976.3
1	25.40	250	300	338.8	406.5	580	696	786.5	943.8	900	1080	1220.4	1464.5
1 1/8	25.58	-	-	-	-	800	880	1084.8	1193.3	1280	1440	1735.7	1952.6
1 1/4	31.75	-	-	-	-	1120	1240	1518.7	1681.4	1820	2000	2467.9	2712.0
1 3/8	34.93	-	-	-	-	1460	1680	1979.8	2278.1	2380	2720	3227.3	3688.3
1 1/2	38.10	-	-	-	-	1940	2200	2630.6	2983.2	3160	3560	4285.0	4827.4

\* Thick nuts must be used with grade 8 bolts.

Size of screw	Thread	Pitch (mm)	Grade 4T  				Grade 7T 				Grade 8T  			
			Torque				Torque				Torque			
			Pound feet		Newton meters		Pound feet		Newton meters		Pound feet		Newton meters	
		min.	max.	min.	max.	min.	max.	min.	max.	min.	max.	min.	max.	
M6	UNC	1.00	3.6	5.8	4.9	7.9	5.8	9.4	7.9	12.7	7.2	10	9.8	13.6
M8	UNC	1.25	7.2	14	9.8	19	17	22	23	29.8	20	26	27.1	35.2
M10	UNC	1.5	20	25	27.1	33.9	34	40	46.1	54.2	38	46	51.5	62.3
M12	UNC	1.75	28	34	37.9	46.1	51	59	69.1	79.9	57	66	77.2	89.4
M14	UNC	2.0	49	56	66.4	75.9	81	93	109.8	126	96	109	130.1	147.7
M16	UNC	2.0	67	77	90.8	104.3	116	130	157.2	176.2	129	145	174.8	196.5
M18	UNC	2.0	88	100	119.2	136	150	168	203.3	227.6	175	194	237.1	262.9
M20	UNC	2.5	108	130	146.3	176.2	186	205	252	277.8	213	249	288.6	337.4
M8	UNF	1.0	12	17	16.3	23	19	27	25.7	36.6	22	31	29.8	42
M10	UNF	1.25	20	29	27.1	39.3	35	47	47.4	63.7	40	52	54.2	70.5
M12	UNF	1.25	31	41	42	55.6	56	68	75.9	92.1	62	75	84	101.6
M14	UNF	1.5	52	64	70.5	86.7	90	106	122	143.6	107	124	145	168
M16	UNF	1.5	69	83	93.5	112.5	120	138	162.6	187	140	158	189.7	214.1
M18	UNF	1.5	100	117	136	158.5	177	199	239.8	269.6	202	231	273.7	313
M20	UNF	1.5	132	150	178.9	203.3	206	242	279.1	327.9	246	289	333.3	391.6

Use the above torques when special torque is not given.

NOTE: These values apply to fasteners as received from supplier, dry, or when lubricated with normal engine oil. They do not apply if extreme pressure lubricants are used.

---

---

## **WARRANTY**

---

PRONOVOST warrants this product to the initial purchaser for the period of one year from the date of purchase against defects in materials and workmanship.

We will replace or repair defective parts free of charge if they are returned to our plant in St-Tite, Quebec, Canada.

Transportation charges are the responsibility of the customer. This warranty is not transferable.

Hydraulic cylinders are covered by the manufacturer of these items.

All PRONOVOST spare parts purchased are covered by a three (3) month warranty.

This warranty becomes void and nul if the equipment is modified, breaks down as the result of an accident, is not operated according to manufacturer's recommendations, damaged by negligence or if maintenance has not been carried out as specified.

Our obligation is limited to the replacement or repair of the defective part. PRONOVOST accepts no responsibility for direct or indirect consequential damages of any kind.









Ce manuel est aussi disponible en français.  
Veuillez téléphoner.



**INNOVATION - EXCELLENCE**

**LES MACHINERIES PRONOVOST INC.**

260, route 159,

Saint-Tite, Quebec, Canada, G0X 3H0

Tel.: (418) 365-7551, Fax: (418) 365-7954

[www.pronovost.qc.ca](http://www.pronovost.qc.ca)