

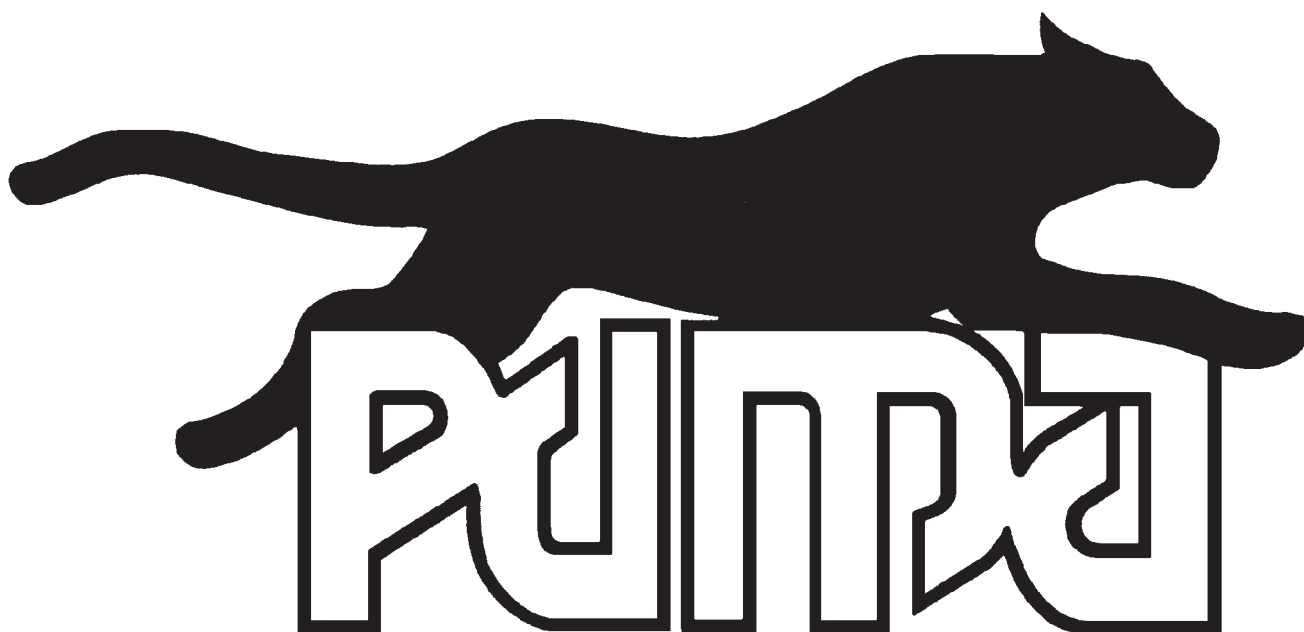

OPERATOR'S / PARTS  
MANUAL



*Snowblowers*  
Models

PUMA-48    PUMA-54    PUMA-64    PUMA-72  
PUMA-74    PUMA-84    PUMA-94



Copyright © Les Machineries Pronovost Inc., 2010

All rights reserved.  
Printed in Canada.

---



---

# **TABLE OF CONTENTS**

---

<b>Section</b>	<b>Item</b>	<b>Page</b>
<b>1</b>	<b>Introduction .....</b>	<b>5</b>
<b>2</b>	<b>Safety .....</b>	<b>6</b>
	General Safety .....	6
	Safety in operation .....	6
	Safety with Maintenance .....	7
	Safety in transport .....	7
	Safety in storage .....	7
<b>3</b>	<b>Decals .....</b>	<b>8</b>
	Safety Decals .....	8
	Maintenance Decals .....	9
<b>4</b>	<b>Maintenance .....</b>	<b>10</b>
<b>5</b>	<b>Storage .....</b>	<b>11</b>
<b>6</b>	<b>Specifications .....</b>	<b>12</b>
<b>7</b>	<b>Parts List .....</b>	<b>13</b>
	Snowblower PUMA-48 PUMA-54 .....	14
	Snowblower PUMA-64 PUMA-72 .....	16
	Snowblower PUMA-74 .....	18
	Snowblower PUMA-84 PUMA-94 .....	20
	Manual Chute Kit MD-48-94 .....	22
	Hydraulic Chute Kit HRD-48-94 .....	23
	Hydraulic Orbit Chute Kit HRD-48-94 .....	24
	P.T.O. Shaft 6545 .....	25
	P.T.O. Shaft 6408-E .....	26
	P.T.O. Shaft 6248-EG .....	27
	P.T.O. Shaft 8114-EG .....	28
	P.T.O. Shaft 8202 .....	29
	Gear Box 6550 .....	30
	Gear Box 6451 .....	31
	Gear Box 8251 .....	32
	Cylinder 25TR04 .....	33
	Cylinder 25TR08 .....	34
	Motor MLH-125-250-315 .....	35
<b>8</b>	<b>Torque chart .....</b>	<b>36</b>
<b>9</b>	<b>Warranty .....</b>	<b>37</b>



---

---

# ***INTRODUCTION***

---

Your Snowblower was carefully designed and we are confident it will meet your requirements in terms of quality, performance and reliability.

This manual was prepared to assist you in the safe operation of your new Snowblower. It contains important information which will help you achieve excellent returns with your Snowblower.

Please read this manual completely before operating your Snowblower and keep it for future reference.

Before starting the machine, you or any other person who will be operating the Snowblower must familiarize yourself with the safety recommendations and the operating instructions. Please read carefully and be sure to understand and follow all recommendations and procedures.

In this manual, the right and left sides are identified as shown on Figure 1.

If you require additional information on your Snowblower, please contact your PRONOVOST Dealer.

**NOW** take a moment to enter the model, serial number and the date of purchase of your Snowblower in the space provided.

When ordering parts from your Dealer, please refer to these numbers for a fast and efficient service. Use PRONOVOST parts for replacement.

The model and serial numbers are on the name plate shown on Fig. 1.

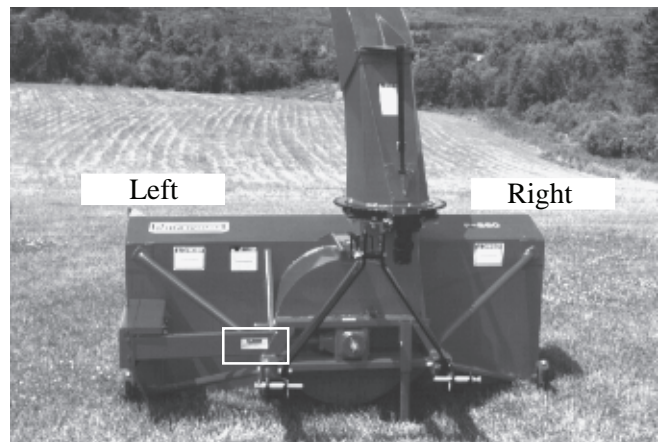

Figure 1

MODEL: \_\_\_\_\_ ✍

SERIAL NO.: \_\_\_\_\_ ✍

DATE OF PURCHASE: \_\_\_\_\_ ✍

---

---

# ***SAFETY***

---

## ***GENERAL SAFETY***

### **WHEN YOU SEE THIS SYMBOL**



**ATTENTION!**

**BE ALERT  
YOUR SAFETY IS INVOLVED**

This symbol «**SAFETY ALERT**» is used in this manual and on the safety decals on the Snowblower. It warns you of the possibility of danger. Carefully read, understand and follow all safety recommendations before operating the Snowblower.

- 1) Careful operation is the best assurance against accidents. Carefully read this manual and follow all recommendations before operating your Snowblower. It is the owner's responsibility to make sure that anyone who will operate the Snowblower will read this manual before operating the equipment.
- 2) Familiarize yourself with all controls and always be ready to stop the Snowblower quickly in case of emergency.
- 3) Never let a child operate the Snowblower.
- 4) Do not modify the Snowblower. Any non authorized modification may affect the efficiency and/or safety of the equipment.
- 5) Never operate the Snowblower with defective parts or if damaged in any way. Have it repaired before operating.
- 6) Make sure all fasteners are in place and properly secured or tightened. Refer to torque chart on page 36.
- 7) Avoid wearing loose fitting clothing when working with the Snowblower. These could get entangled in moving parts of the equipment and cause accidents.

- 8) Prolonged exposure to noise may hamper hearing. Protect yourself by wearing adequate protection devices.
- 9) Hydraulic fluids under pressure can damage your skin. Do not use your hands to locate a leak.
- 10) Before the beginning of the snow season, inspect all areas where the Snowblower will be used and remove any object which may cause an accident and/or damage the equipment.
- 11) Never operate your Snowblower in poor visibility or without proper lighting conditions.

## ***SAFETY IN OPERATION***

- 1) Be sure there are no obstructions around the equipment and that no one stands near the equipment when in operation.
- 2) Do not operate an engine in a confined or non ventilated area.
- 3) Do not perform any adjustments, cleaning, maintenance or repairs with the engine running. The engine must be stopped and the P.T.O. disengaged. Preferably remove the key from the ignition.
- 4) Wear adequate clothing when working in cold or windy conditions.
- 5) Before operating, make sure the P.T.O. is properly installed and secured.
- 6) Before starting-up the Snowblower, make sure the auger and drum areas are free of ice.
- 7) Put P.T.O. control in neutral position before starting engine.
- 8) Keep hands, feet and clothing away from moving parts of the Snowblower. Stay away from the discharge chute.
- 9) Before unplugging the chute, always disengage the P.T.O., stop the engine and relieve all hydraulic pressures.

---

---

## ***SAFETY (cont'd)***

---

- 10) Do not operate in excessive inclined conditions. Be careful when turning in slopes.
- 11) Never operate your Snowblower with missing guards or without protective devices in place.
- 12) Do not operate your Snowblower near buildings, windows or other vehicles without prior and proper adjustment of the chute deflector.
- 13) Never aim discharge chute towards people or animals. This may cause serious injuries.
- 14) Always reduce operating speed in slippery conditions.
- 15) Be careful when backing-up, make sure you have good visibility.
- 16) Always be on the lookout for objects which may enter the Snowblower.
- 17) If undue vibrations are felt, disengage the P.T.O., stop the motor and look for the cause of the vibration. Vibration is usually the indication of a problem.
- 18) At the end of the operation, disengage the P.T.O., lower the Snowblower, put transmission in neutral, apply parking brake, stop engine and remove the key from the ignition.

### ***SAFETY WITH MAINTENANCE***

- 1) Perform the Snowblower maintenance according to recommendations contained in this manual.
- 2) Stop engine and relieve all hydraulic pressures before doing inspection, maintenance or repairs.
- 3) Never perform any work under the Snowblower while it is supported only by the tractor's hydraulic system. It must be completely supported by wooden blocks or other safe means.

### ***SAFETY IN TRANSPORT***

- 1) On public roads, use proper safety lights and check local regulations.
- 2) Be alert while driving on the road. Never carry passengers.
- 3) Always disengage P.T.O. while moving from one area of work to another.
- 4) The recommended road speed should be such as to maintain full control over steering and braking.
- 5) Be careful while backing up, make sure you have good visibility.

### ***SAFETY IN STORAGE***

- 1) Provide adequate supports to prevent any accidental overturning of the Snowblower.
- 2) Do not let children play in the area where the Snowblower is stored.

# DECALS

## SAFETY DECALS

The safety decals are affixed wherever special safety precautions are indicated. Locate them on the machine and read them carefully. If a decal is damaged, lost or illegible, install a new one. Each decal is shown and identified with a part number.



Figure 2

Part no.: 190-11671

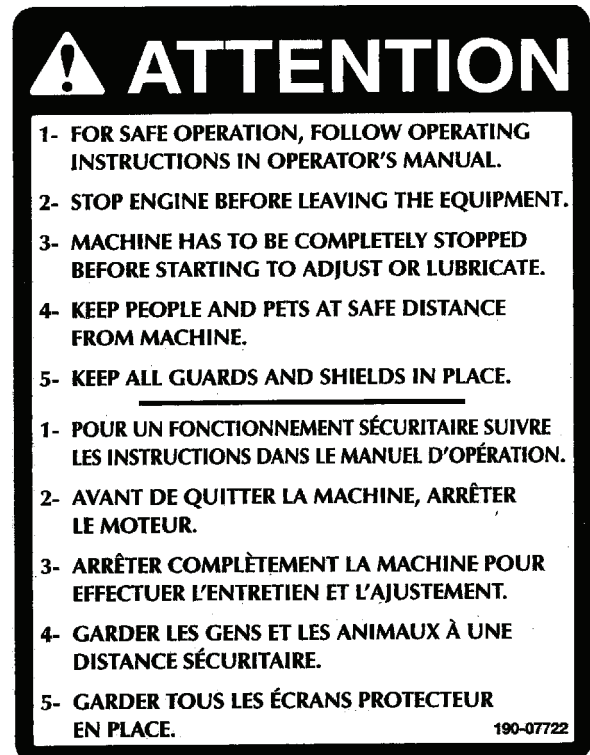

Figure 3

Part no.: 190-07722

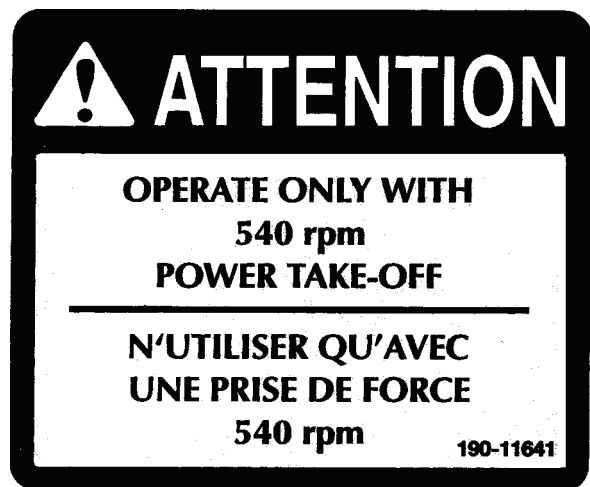

Figure 4

Part no.: 190-11641



**DECALS (cont'd)**



Figure 5

Part no.: A108



Figure 6

Part no.: A 109

**MAINTENANCE DECALS**

The maintenance decals indicate the points requiring lubrication. Refer to maintenance section for more details.



Figure 7

Part no.: 190-11581



Figure 8

Part no.: A 106

---

---

# MAINTENANCE

---

---

- 1) Wipe off all grease fittings with a clean cloth before adding grease in order to avoid injecting dirt and sand.
- 2) Repair or replace damaged grease fittings.
- 3) Lubricate all grease fittings every 8 hours of operation.
- 4) Oil drive chain every 8 hours of operation.
- 5) Lubricate P.T.O. shaft as indicated below:

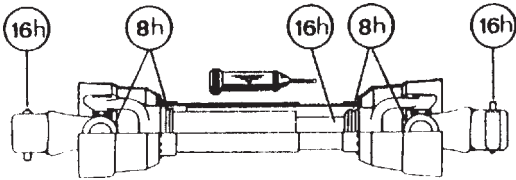

Pull out the P.T.O. and lubricate between the two tubes with low temperature grease. Drive line tubes must slide easily even in cold weather. Clean off old hardened grease and apply fresh grease as needed.

- 6) Check oil level in gear box once a month. If necessary add oil.

- 7) Check tension of drive chain every 24 hours of operation and adjust if necessary.
- 8) Check for tightness of bearing collars every 48 hours of operation.
- 9) Change gearbox oil once a year. Use gear box oil S.A.E. W90 rated API, class GL-5.
- 10) Check all nuts and bolts once a year. If necessary use torque chart on page 36.
- 11) For the auger drive shaft, always use grade 2 shear bolts.
- 12) For the PTO shaft, always use a grade 8.8 shear bolt.
- 13) UHMW slides do not require lubrication except at the end of the season in order to prevent corrosion of steel components that are in contact with the UHMW material.

---

---

## ***STORAGE***

---

- 1) Store the Snowblower in a cool, dry place.
- 2) Support the Snowblower with wooden blocks.
- 3) Keep all piston rods in the retracted position. This will assure better protection against the elements.
- 4) Clean your Snowblower.
- 5) Thoroughly inspect all parts of the Snowblower. Replace or repair worn or defective parts.
- 6) Touch-up or repaint if necessary.
- 7) Lubricate all points before storage.

# ***SPECIFICATIONS***

## **SPECIFICATIONS**

<b>MODEL</b>	<b>PUMA-48</b>	<b>PUMA-54</b>	<b>PUMA-64</b>	<b>PUMA-72</b>	<b>PUMA-74</b>	<b>PUMA-84</b>	<b>PUMA-94</b>
Horse power recommended	16 to 25	16 to 25	18 to 30	20 to 35	25 to 40	40 to 75	50 to 75
Cutting width	48"	54"	64"	72"	74"	84"	94"
Cutting height	25"	25"	26 1/2"	26 1/2"	30"	34"	34"
Drum diameter	21"	21"	22"	22"	24"	28"	28"
Depth of drum	7"	7"	7"	7"	8"	11"	11"
Impeller blades	4	4	4	4	4	4	4
Size of impeller shaft	1"	1"	1 1/4"	1 1/4"	1 9/16"	1 9/16"	1 9/16"
Height - impeller center	12 3/4"	12 3/4"	13 1/4"	13 1/4"	16"	18 1/2"	18 1/2"
Impeller RPM	540	540	540	540	540	540	540
Accelerator 540/756	Option	Option	Option	Option	Option	Option	Option
Auger diameter	16"	16"	16"	16"	17"	20"	20"
Drive chain	50	50	50	50	60	60	60
Chute	Included	Included	Included	Included	Included	Included	Included
Antifriction ring for chute	Included	Included	Included	Included	Included	Included	Included
Chute rotation mechanism	Manual	Option	Option	Option	Option	Option	Option
	Hyd. cylinder	Option	Option	Option	Option	Option	Option
	Hyd. motor	Option	Option	Option	Option	Option	Option
Deflector adjustment	Manual	Included	Included	Included	Included	Included	Included
	Hyd. cylinder	Option	Option	Option	Option	Option	Option
Hitch category	1	1	1	1	1 & 2	1 & 2	1 & 2
PTO shaft category	T20	T20	T20	T40	T40	T50	T60
Adjustable skid shoes	Included	Included	Included	Included	Included	Included	Included
Storage support	Included	Included	Included	Included	Included	Included	Included
Weight (lbs)	366	374	413	430	639	955	980

Design and specifications subject to change without notice.

# PARTS LIST

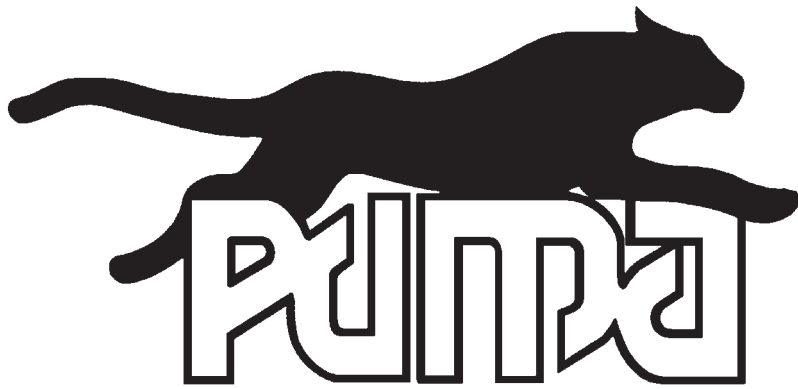

# SNOWBLOWERS PUMA-48 PUMA-54

170-05741

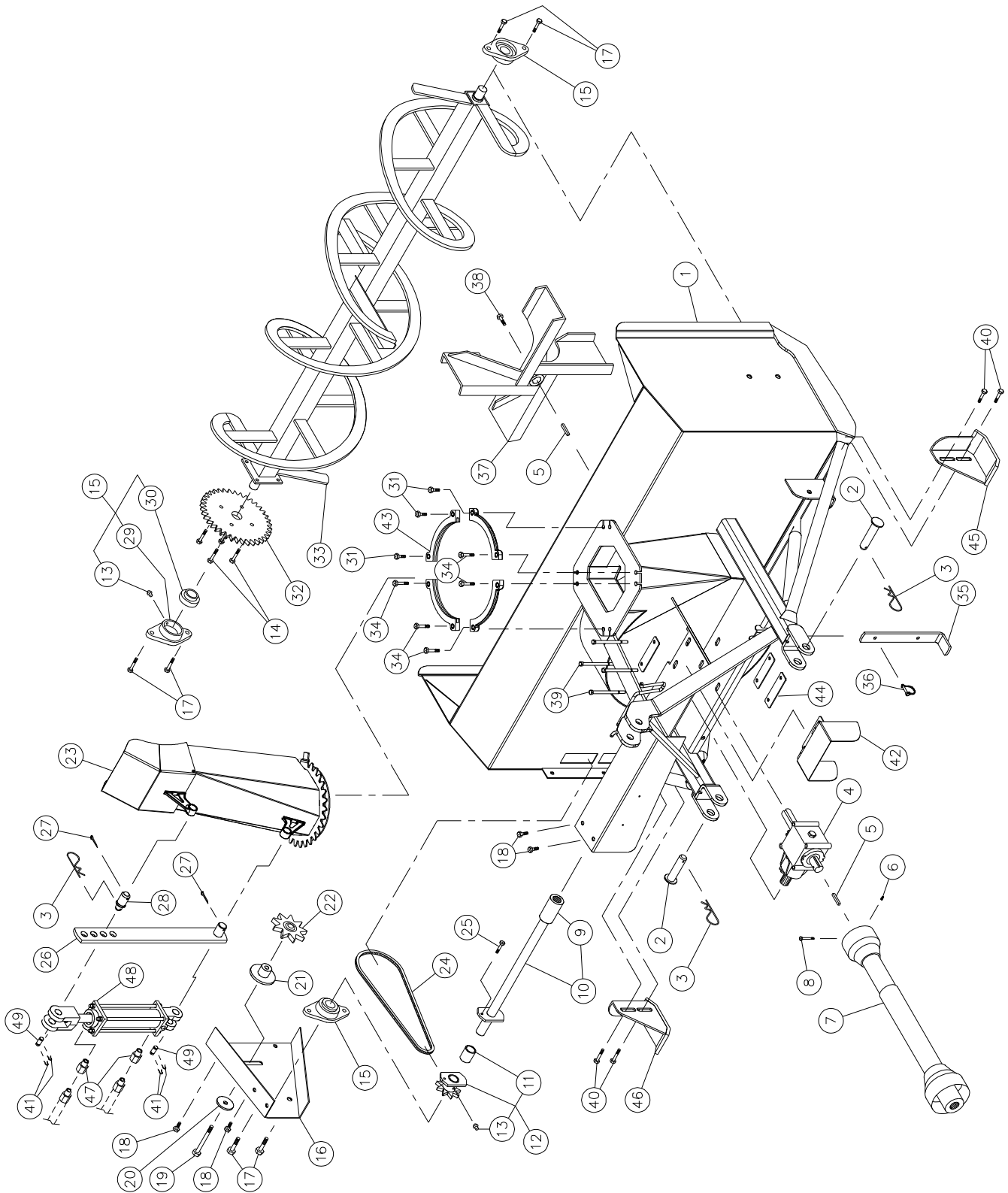

# SNOWBLOWERS PUMA-48 PUMA-54 PUMA-64 (cont'd)

REF.	PART #	DESCRIPTION	QTY	
			48	54
1	120-04504	Frame 48" .....	1	-
1	120-00545	Frame 54" .....	-	1
2	110-03331	Pin category 1 .....	2	2
3	Std.	Hitch pin clip 5/32" .....	3	3
4	6550	Gear box 1" ø x 1-15 splines .....	1	1
5	140-03871	Key 1/4" x 1/4" x 1 5/8" lg .....	2	2
6	323-32160	Hexagonal socket set screw 1/4"-20 x 3/8" lg .....	1	1
7	6545	P.T.O. shaft - 1" ø x 1 3/8"-6 (T20) .....	1	1
8	300-32370	Bolt 1/4" NC x 2 1/2" lg + nylon locknut .....	1	1
9	6565	Splined adaptor 1"-15 .....	1	1
10	110-22591	Auger drive shaft 18 1/4" lg overall (including #9) .....	1	-
10	110-02821	Auger drive shaft 21 1/4" lg overall (including #9) .....	-	1
11	6566	Bushing 1" i.d. x 1 1/8" o.d. x 1 1/2" lg .....	1	1
12	6567	Sprocket # 50 + shearplate (including # 11 and # 13) .....	1	1
13	Std.	Grease fitting 1/4"-28 straight .....	5	5
14	300-36280	Bolt 3/8" NC x 1 1/4" lg + two-way locknut .....	4	4
15	UCFLD205-16	Bearing 1"ø + flange .....	3	3
16	130-03301	Chain guard .....	1	1
17	300-40250	Bolt 1/2" NC x 1" lg + nylon locknut (thin) .....	6	6
18	300-36250	Bolt 3/8" NC x 1" lg + nylon locknut .....	4	4
19	300-40400	Bolt 1/2" NC x 3" lg + nylon locknut .....	1	1
20	378-40340	Flat washer 1/2" d.i. x 2" d.e. ....	1	1
21	110-07732	Idler .....	1	1
22	6604	Idler sprocket #50 .....	1	1
23	110-02893	Chute .....	1	1
24	190-00502	Chain #50 x 51 7/8" lg .....	1	1
24	26A50	Connecting link #50 .....	1	1
24	59-50	Offset link #50 .....	1	1
25	312-32250	Shear bolt 1/4" NC x 1" lg grade 2 + nylon locknut .....	1	1
26	110-02981	Chute adjusting bar .....	1	1
27	Std.	Cotter pin 5/32" x 1 1/2" .....	2	2
28	150-00641	Pin for chute adjusting bar .....	1	1
29	FLD205	Flange .....	3	3
30	UC205-16	Bearing 1" ø .....	3	3
31	300-36325	Bolt 3/8" NC x 1 3/4" lg + nylon locknut & (2) flat washer .....	3	3
32	6288	Sprocket 50A36 T 1" ø .....	1	1
33	110-22631	Auger PUMA-48 .....	1	-
33	110-02941	Auger PUMA-54 .....	-	1
34	300-36340	Bolt 3/8" NC x 2" lg + nylon locknut + (2) flat washer .....	5	5
35	140-23311	Storage support .....	1	1
36	8112	Lock pin 1/4" .....	1	1
37	110-45241	Impeller 7" x 21" ø 4 blades T 1" ø .....	1	1
38	329-34280	Impeller cap screw 5/16" x 1 1/4" lg + lock washer .....	1	1
39	300-36550	Bolt 3/8" NC x 5 1/2" lg + nylon locknut .....	4	4
40	300-38280	Bolt 7/16" NC x 1 1/4" lg + nylon locknut + flat washer .....	4	4
41	Std.	Hairpin cotter (4) .....	opt.	opt.
42	110-42891	Hinged P.T.O. shroud .....	1	1
43	110-45111	Chute retaining bracket .....	1	1
44	130-83731	Back plate .....	3	3
45	110-15341	Skid shoe (right side) .....	1	1
46	110-15342	Skid shoe (left side) .....	1	1
47	RSP-1/16x06 NPT	Kit of two unidirectionals restrictors .....	opt.	opt.
47	RSP-1/16x08 NPT	Kit of two unidirectionals restrictors .....	opt.	opt.
48	25TRO4	Cylinder 2 1/2" dia. x 4" stroke .....	opt.	opt.
49	6004	Clevis pin 1" x 3 1/8" (2) .....	opt.	opt.

# SNOWBLOWER PUMA-64 PUMA-72

170-05321

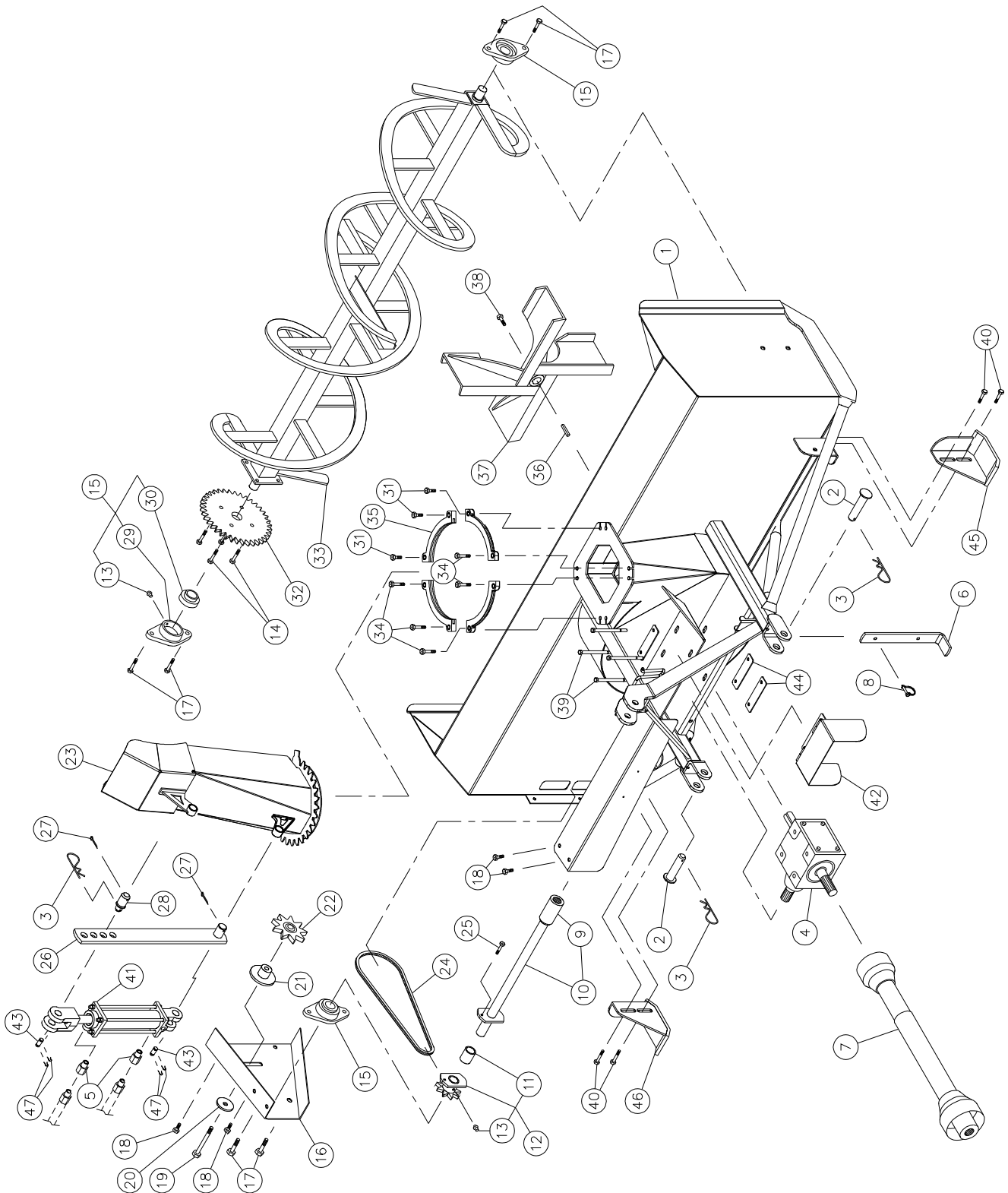



# SNOWBLOWER PUMA-64 PUMA-72 (cont'd)

REF.	PART #	DESCRIPTION	QTY	
			64	72
1	120-00555	Frame 64" .....	1	-
1	120-07451	Frame 72" .....	-	1
2	110-03331	Pin category 1 .....	2	2
3	Std.	Hitch pin clip 5/32" .....	3	3
4	6451	Gear box T281 .....	1	1
5	RSP-1/16x06 NPT	Kit of two unidirectionals restrictors .....	opt.	opt.
5	RSP-1/16x08 NPT	Kit of two unidirectionals restrictors .....	opt.	opt.
6	140-23311	Storage support .....	1	1
7	6408-E	P.T.O. shaft (T20) .....	1	-
7	6248-EG	P.T.O. shaft (T40) .....	-	1
8	8112	Lock pin 1/4" .....	1	1
9	6466	Splined adaptor 1 1/4"-19 .....	1	1
10	110-02972	Auger drive shaft 25 9/32" lg overall (including #9) .....	1	-
10	110-42601	Auger drive shaft 29 9/32" lg overall (including #9) .....	-	1
11	6566	Bushing 1" i.d. x 1 1/8" o.d. x 1 1/2" lg .....	1	1
12	6567	Sprocket # 50 + shearplate (including #11 and #13) .....	1	1
13	Std.	Grease fitting 1/4"-28 straight .....	5	5
14	300-36280	Bolt 3/8" NC x 1 1/4" lg + two-way locknut .....	4	4
15	UCFLD205-16	Bearing 1" ø + flange .....	3	3
16	130-77461	Chain guard .....	1	1
17	300-40250	Bolt 1/2" NC x 1" lg + nylon locknut (thin) .....	6	6
18	300-36250	Bolt 3/8" NC x 1" lg + nylon locknut .....	4	4
19	300-40400	Bolt 1/2" NC x 3" lg + nylon locknut .....	1	1
20	378-40340	Flat washer 1/2" i.d. x 2" o.d. ....	1	1
21	110-07732	Idler .....	1	1
22	6604	Idler sprocket #50 .....	1	1
23	110-02893	Chute .....	1	1
24	190-11902	Chain #50 x 53 1/8" lg .....	1	1
24	26A50	Connecting link #50 .....	1	1
24	59-50	Offset link #50 .....	1	1
25	312-32250	Shear bolt 1/4" NC x 1" lg grade 2 + nylon locknut .....	1	1
26	110-02981	Chute adjusting bar .....	1	1
27	Std.	Cotter pin 5/32" x 1 1/2" .....	2	2
28	150-00641	Pin for chute adjusting bar .....	1	1
29	FLD205	Flange .....	3	3
30	UC205-16	Bearing 1" ø .....	3	3
31	300-36325	Bolt 3/8" NC x 1 3/4" lg + nylon locknut & (2) flat washer .....	3	3
32	6288	Sprocket 50A36 hole 1" ø .....	1	1
33	110-02961	Auger for PUMA-64 .....	1	-
33	110-20991	Auger for PUMA-72 .....	-	1
34	300-36340	Bolt 3/8" NC x 2" lg + nylon locknut & (2) flat washer .....	5	5
35	110-45111	Chute retaining bracket .....	4	4
36	6276	Key 1/4" x 1/4" x 1 3/4" lg .....	1	1
37	110-42641	Impeller 7" x 22" ø 4 blades T 1 1/4" ø .....	1	1
38	300-36280	Impeller cap screw 3/8" x 1 1/4" lg (ass. with lock-tite 242) + lock washer .....	1	1
39	300-36550	Bolt 3/8" NC x 5 1/2" lg + nylon locknut .....	4	4
40	300-38280	Bolt 7/16" NC x 1 1/4" lg + nylon locknut + flat washer .....	4	4
41	25TR04	Cylinder 2 1/2" dia. x 4" stroke .....	opt.	opt.
42	110-45961	Hinged P.T.O. shroud .....	1	1
43	6004	Clevis pin 1" x 3 1/8" lg (2) .....	opt.	opt.
44	130-78551	Back plate .....	4	4
45	110-15341	Skid shoe (right side) .....	1	1
46	110-15342	Skid shoe (left side) .....	1	1
47	Std.	Hairpin cotter 7/8" (4) .....	opt.	opt.

# SNOWBLOWERS PUMA-74

170-05761

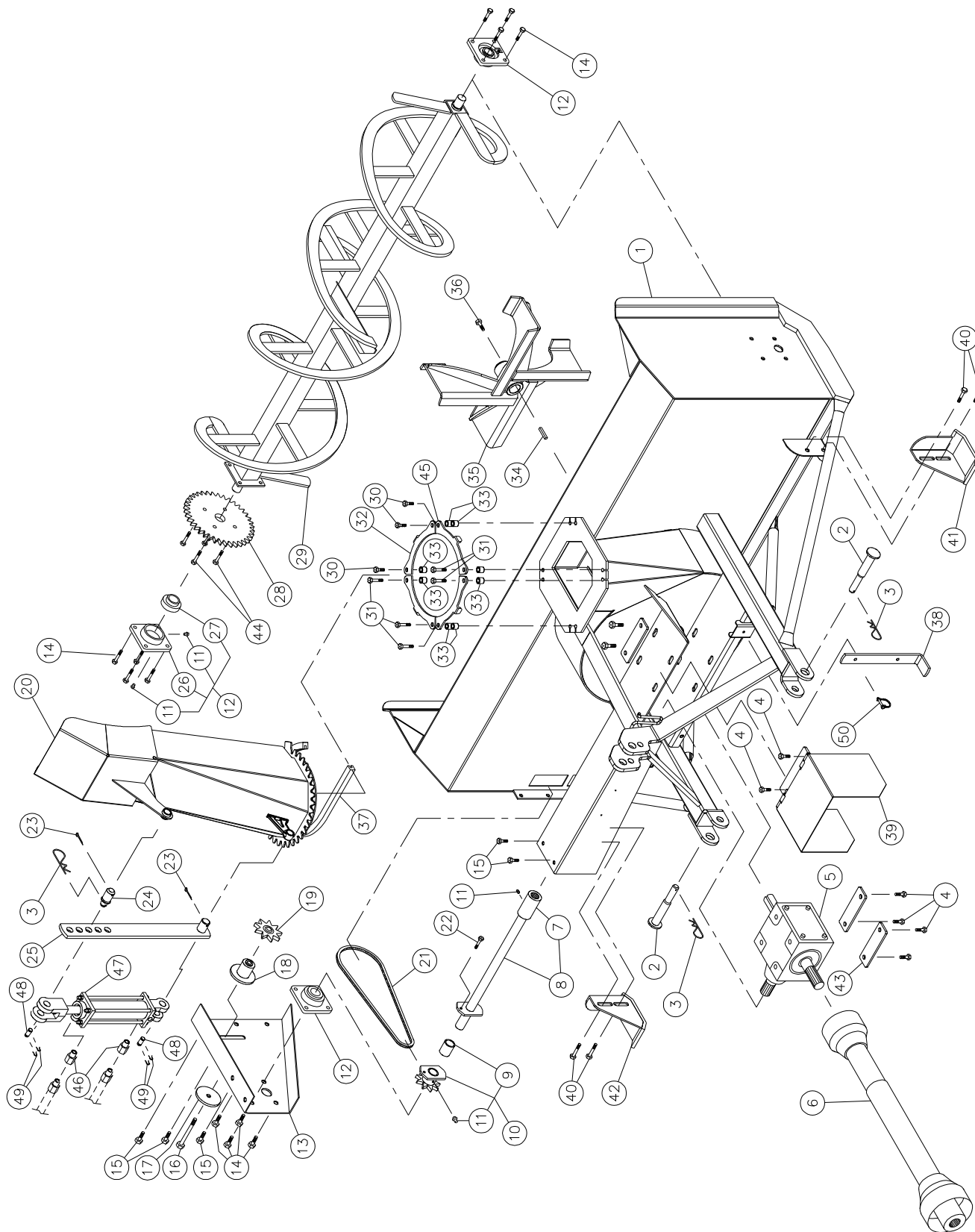

## SNOWBLOWERS PUMA-74 (cont'd)

REF.	PART #	DESCRIPTION	QTY
1	120-00576	Frame 74" .....	1
2	110-03341	Pin category 1 & 2 .....	2
3	Std.	Hitch pin clip 5/32" .....	3
4	300-40280	Bolt 1/2" NC x 1 1/4" lg + nylon lock nut .....	8
5	8251	Gear box T27D .....	1
6	6248-EG	P.T.O. shaft (T40) .....	1
7	6466	Splined adaptor 1 1/4"-19 .....	1
8	110-45821	Auger drive shaft 26 1/16" lg overall (including #7) .....	1
9	6568	Bushing 1 1/4" i.d. x 1 7/16" o.d. x 2 1/2" lg .....	1
10	6569	Sprocket # 60 + shearplate (including #9 and #11) .....	1
11	Std.	Grease fitting 1/4"-28 straight .....	8
12	UCFD207-20	Bearing 1 1/4" ø + flange & 2 grease fittings (straight) .....	3
13	130-03613	Chain guard .....	1
14	300-40310	Bolt 1/2" NC x 1 1/2" lg + nylon locknut .....	12
15	300-38250	Bolt 7/16" NC x 1" lg + nylon locknut .....	5
16	300-40430	Bolt 1/2" NC x 3 1/2" lg + nylon locknut .....	1
17	130-08461	Flat washer 9/16" d.i. x 3" d.e. ....	1
18	110-07781	Idler .....	1
19	8186	Idler sprocket #60 .....	1
20	110-03043	Chute .....	1
21	190-13091	Chain #60 x 62 1/4" lg .....	1
21	26A60	Connecting link #60 .....	1
21	59-60	Offset link #60 .....	1
22	312-32250	Shear bolt 1/4" NC x 1" lg grade 2 + nylon locknut .....	1
23	Std.	Cotter pin 5/32" x 1 1/2" .....	2
24	150-00641	Pin for chute adjusting bar .....	1
25	110-02991	Chute adjusting bar .....	1
26	FD207	Flange for 2 grease fittings .....	3
27	UC207-20	Bearing 1 1/4" ø .....	3
28	8021	Sprocket 60A38 T 1 1/4" ø .....	1
29	110-03062	Auger PUMA-74 .....	1
30	300-36340	Bolt 3/8" NC x 2" lg + nylon locknut & flat washer .....	3
31	300-36355	Bolt 3/8" NC x 2 1/4" lg + nylon locknut & flat washer .....	5
32	130-31291	Chute retaining bracket .....	3
33	160-07371	Spacer 11/16" o.d. x 7/16" i.d. x 5/8" lg .....	8
34	8030	Key 3/8" x 3/8" x 3 1/2" lg .....	1
35	110-03033	Impeller 8" x 22" ø 4 blades T 1 1/4" ø .....	1
36	44300	Impeller cap screw 5/8" x 1 3/4" lg (ass'd with locktite 242) + lock washer .....	1
37	190-04091	U-shaped UHMW x 38 7/8" .....	1
38	140-23261	Storage support .....	1
39	110-45991	Hinged P.T.O. shroud .....	1
40	300-40310	Bolt 1/2" NC x 1 1/2" lg + nylon locknut + flat washer .....	4
41	110-15391	Skid shoe (right side) .....	1
42	110-15392	Skid shoe (left side) .....	1
43	130-05972	Back plate .....	3
44	300-38310	Bolt 7/16" NC x 1 11/2" lg + two-way locknut .....	4
45	130-31281	Chute retaining bracket with chute stop .....	1
46	RSP-1/16x06 NPT	Kit of two unidirectionals restrictors .....	opt.
46	RSP-1/16x08 NPT	Kit of two unidirectionals restrictors .....	opt.
47	25TR08	Cylinder 2 1/2" dia. x 8" stroke .....	opt.
48	6004	Clevis pin 1" x 3 1/8" (2) .....	opt.
49	Std.	Hairpin cotter (4) .....	opt.
50	8112	Lock pin 1/4" .....	1

# SNOWBLOWERS PUMA-84 PUMA-94

170-05721

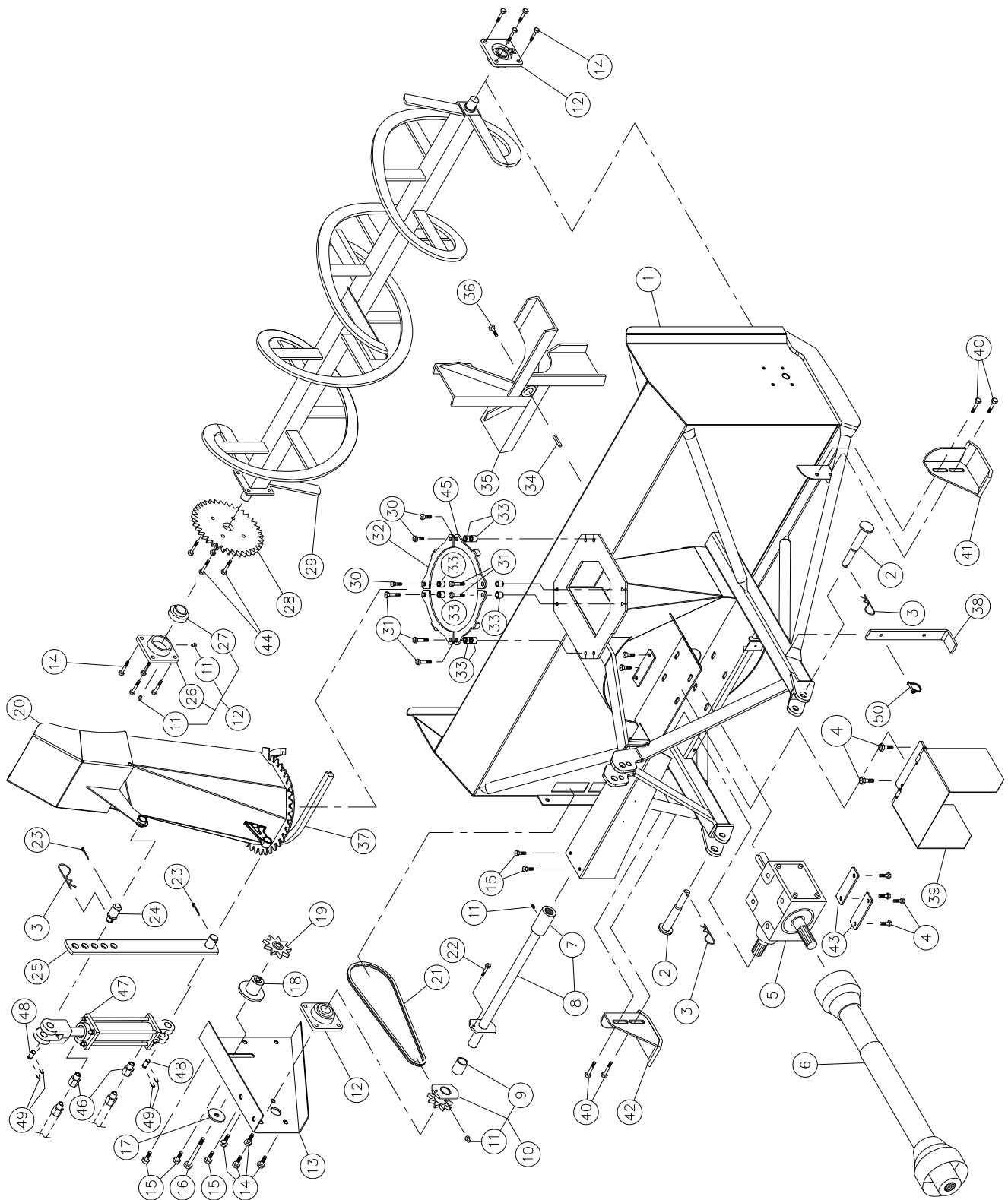

# SNOWBLOWERS PUMA-84 PUMA-94 (cont'd)

REF.	PART #	DESCRIPTION	QTY	
			8	9
1	120-07851	Frame 84" .....	1	-
1	120-07881	Frame 94" .....	2	2
2	110-03341	Pin category 1 & 2 .....	-	1
3	Std.	Hitch pin clip 5/32" .....	2	2
4	300-40280	Bolt 1/2" NC x 1 1/4" lg + lock washer .....	3	3
5	8251	Gear box T27D .....	8	8
6	8114-EG	P.T.O. (T50) .....	1	1
6	8202	P.T.O. (T60) .....	1	-
7	6466	Splined adaptor 1 1/4"-19 (welded) .....	-	1
8	110-03352	Auger drive shaft 31 3/16" lg overall (including #7) .....	1	1
8	110-04282	Auger drive shaft 36 3/16" lg overall (including #7) .....	1	-
9	6568	Bushing 1 1/4" i.d. x 1 7/16" o.d. x 2 1/2" lg .....	-	1
10	6570	Sprocket # 60 + shearplate (including #9 and #11) .....	1	1
11	Std.	Grease fitting 1/4"-28 straight .....	1	1
12	UCFD207-20	Bearing 1 1/4" ø + flange & 2 grease fitting .....	8	8
13	130-04031	Chain guard .....	3	3
14	300-40310	Bolt 1/2" NC x 1 1/2" lg + nylon locknut .....	1	1
15	300-38250	Bolt 7/16" NC x 1" lg + nylon locknut .....	12	12
16	300-40430	Bolt 1/2" NC x 3 1/2" lg + nylon locknut .....	5	5
17	130-08461	Flat washer 9/16" d.i. x 3" d.e. ....	1	1
18	110-07781	Idler .....	1	1
19	8186	Idler sprocket #60 .....	1	1
20	110-03183	Chute 84-94 .....	1	1
21	190-00581	Chain #60 x 70 3/8" lg .....	1	1
21	26A60	Connecting link #60 .....	1	1
21	59-60	Offset link #60 .....	1	1
22	312-34280	Shear bolt 5/16" NC x 1 1/4" lg grade 2 + nylon locknut .....	1	1
23	Std.	Cotter pin 5/32" x 1 1/2" .....	2	2
24	150-00641	Pin for chute adjusting bar .....	1	1
25	110-02991	Chute adjusting bar .....	1	1
26	FD207	Flange for 2 grease fitting .....	3	3
27	UC207-20	Bearing 1 1/4" ø .....	3	3
28	8021	Sprocket 60A38 T 1 1/4" ø .....	1	1
29	110-45581	Auger PUMA-84 .....	1	-
29	110-45601	Auger PUMA-94 .....	-	1
30	300-38340	Bolt 7/16" NC x 2" lg + nylon locknut & flat washer .....	3	3
31	300-38350	Bolt 7/16" NC x 2 1/4" lg + nylon locknut & flat washer .....	5	5
32	130-31311	Chute retaining bracket .....	3	3
33	160-07401	Spacer .....	8	8
34	8030	Key 3/8" x 3/8" x 3 1/2" lg .....	1	1
35	110-45571	Impeller 11" x 28" ø 4 blades T 1 9/16" ø .....	1	1
36	300-44300	Bolt 5/8" NC x 1 3/4" lg + lock washer .....	1	1
37	190-04101	U-shaped UHMW x 51 7/16" .....	1	1
38	140-23322	Storage support .....	1	1
39	110-45991	Hinged P.T.O. shroud .....	1	1
40	300-40310	Bolt 1/2" x 1 1/2" lg + nylon locknut + flat washer .....	1	1
41	110-15391	Skid shoe (right side) .....	4	4
42	110-15392	Skid shoe (left side) .....	1	1
43	130-05972	Back plate .....	3	3
44	300-38310	Bolt 7/16" NC x 1 1/2" lg + two-way locknut .....	4	4
45	130-31301	Chute retaining bracket with chute stop .....	1	1
46	RSP-1/16x06 NPT	Kit of two unidirectionals restrictors .....	opt.	opt.
46	RSP-1/16x08 NPT	Kit of two unidirectionals restrictors .....	opt.	opt.
47	25TR08	Cylinder 2 1/2" dia. x 8" stroke .....	opt.	opt.
48	6004	Clevis pin 1" x 3 1/8" (2) .....	opt.	opt.
49	Std.	Hairpin cotter (4) .....	opt.	opt.
50	8112	Lock pin 1/4" .....	1	1

# MANUAL CHUTE KIT MD-4872, MD-74 and MD-8494

170-04303

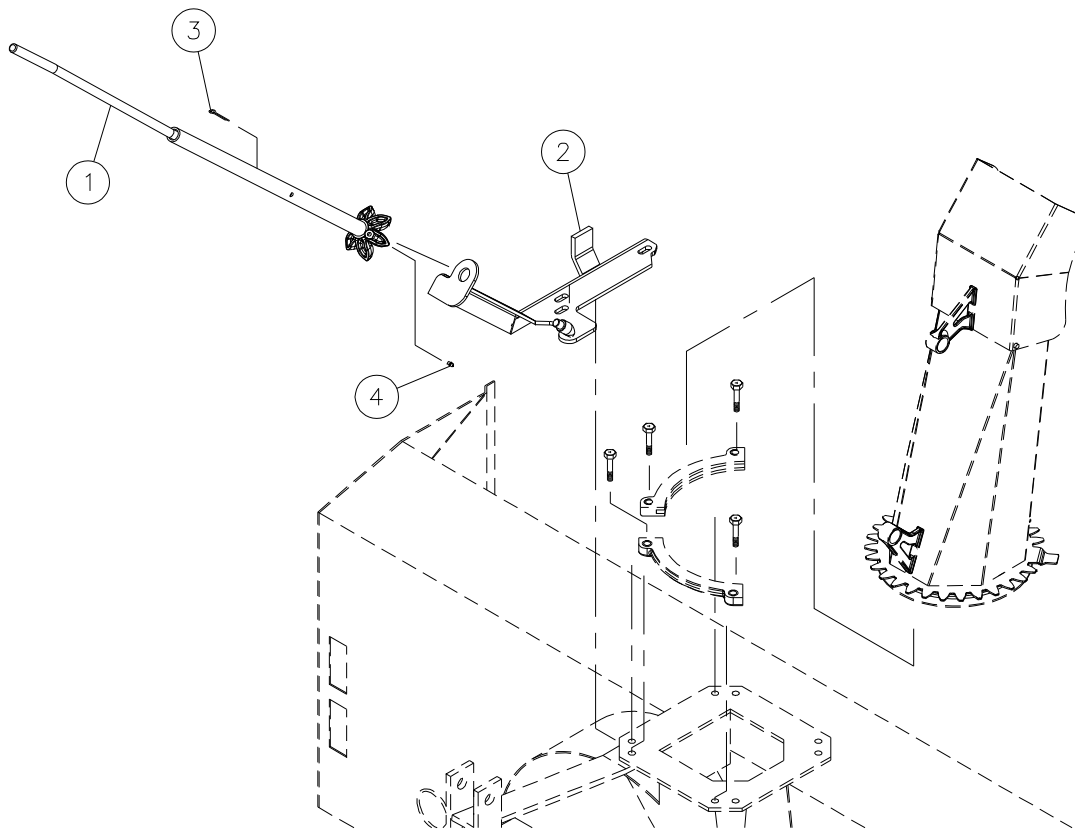

REF.	PART #	DESCRIPTION	QTY		
			MD-4872	MD-74	MD-8494
1	110-27703	Crank .....	1	-	-
1	110-28442	Crank .....	-	1	-
1	110-28272	Crank .....	-	-	1
2	110-27713	Base .....	1	-	-
2	110-28383	Base .....	-	1	-
2	110-28264	Base .....	-	-	1
3	Std.	Roll pin 1/4" x 1 3/4" lg. ....	1	1	1
4	Std.	Grease fitting 1/4"-28 straight .....	1	1	1

# HYDRAULIC CHUTE KIT HRD-4872, HRD-74 and HRD-8494

170-04313

## INSTALLATION OF THE CHUTE ROTATION MECHANISM

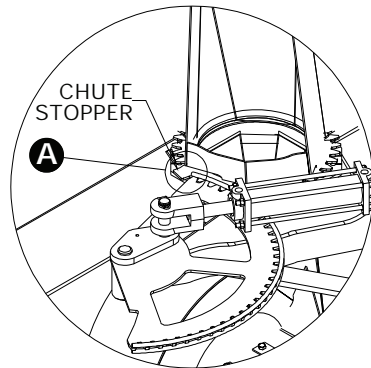

- 1- Put the two first tooth one in the other (see **A**)
- 2- Check and adjust the hydraulic cylinder as indicated before installing:

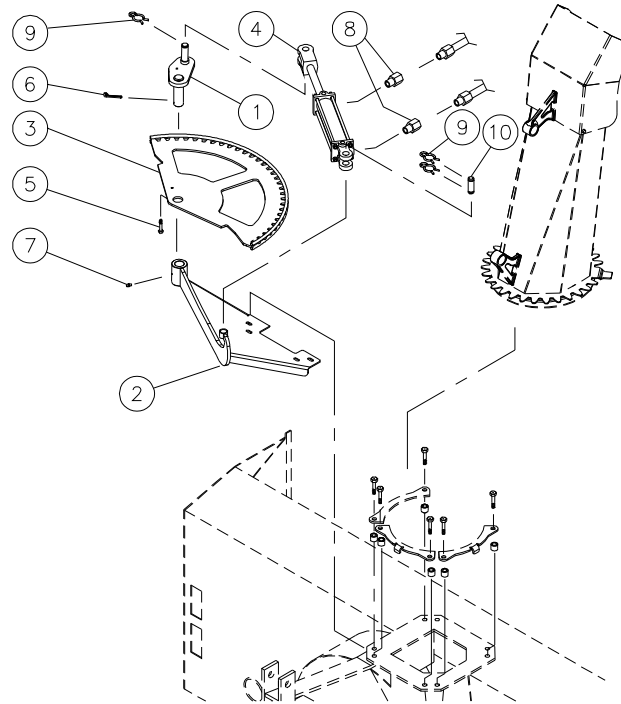

Models	Min	Max
HRD-4872	14 1/4"	18 1/4" (25TR04)
HRD-74	20 1/4"	28 1/4" (25TR08)
HRD-8494	20 1/4"	28 1/4" (25TR08)

REF.	PART #	DESCRIPTION	HRD-4872	HRD-74	HRD-8494
1	110-27653	Pivot .....	1	-	-
1	110-28391	Pivot .....	-	1	-
1	110-28231	Pivot .....	-	-	1
2	110-42171	Base .....	1	-	-
2	110-28402	Base .....	-	1	-
2	110-28242	Base .....	-	-	1
3	110-27613	Arc .....	1	-	-
3	110-28421	Arc .....	-	1	-
3	110-28251	Arc .....	-	-	1
4	25TR04	Cylinder 2 1/2" x 4" stroke .....	1	-	-
4	25TR08	Cylinder 2 1/2" x 8" stroke .....	-	1	1
5	Std.	Bolt 1/4" NC x 1 1/2" lg grade 5 + nylon locknut .....	1	1	1
6	Std.	Cotter pin 1/4" x 2" .....	1	1	-
6	Std.	Cotter pin 1/4" x 2 1/2" .....	-	-	1
7	Std.	Grease fitting 1/4"-28 straight .....	1	1	1
8	RSP-1/16x06NPT	Kit of two unidirectionals restrictors .....	opt.	opt.	opt.
8	RSP-1/16x08NPT	Kit of two unidirectionals restrictors .....	opt.	opt.	opt.
9	Std.	Hairpin cotter .....	3	3	3
10	60004	Axe de chape 1" x 3 1/8" lg .....	1	1	1

# HYDRAULIC ORBIT CHUTE KIT HMD-4872, HMD-74 and HMD-8494

170-04321

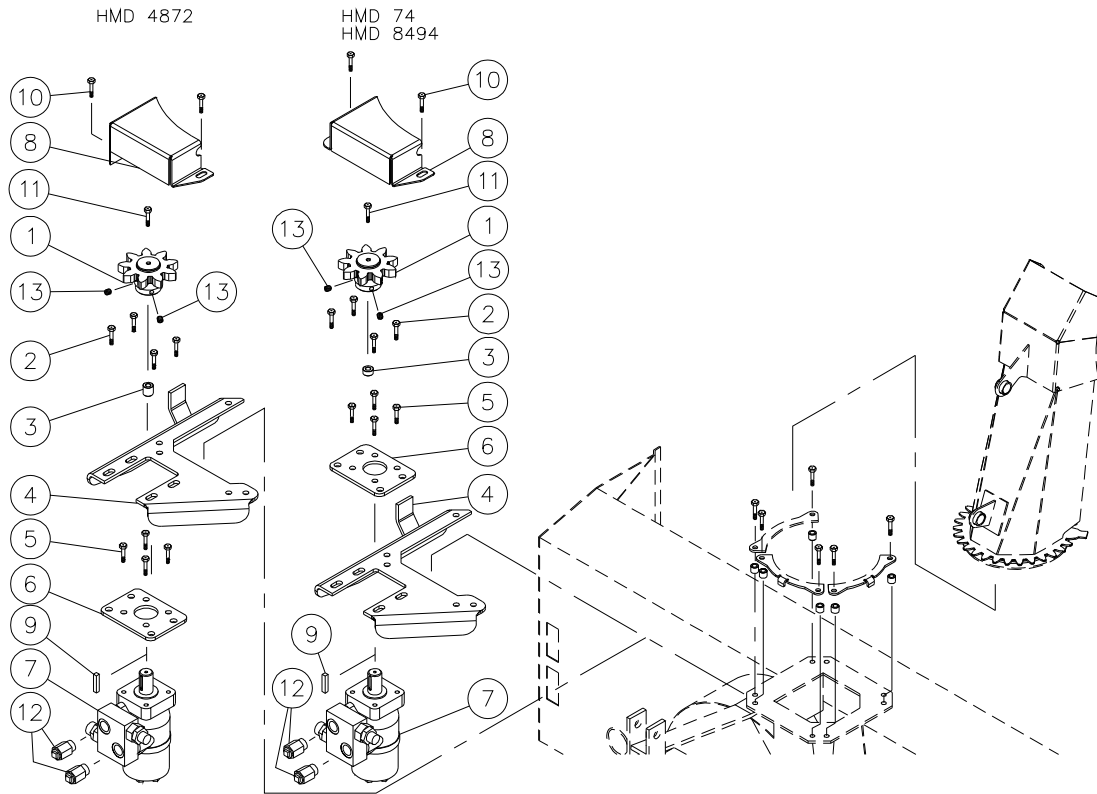

REF.	PART #	DESCRIPTION	QTY		
			HMD-4872	HMD-74	HMD-8494
1	110-32171	Sprocket .....	1	-	-
1	110-33891	Sprocket .....	-	1	1
2	300-38280	Bolt 7/16" NC x 1 1/4" lg + flat washer & nylon locknut .....	4	4	4
3	160-19701	Spacer .....	1	1	1
3	160-21091	Spacer .....	-	1	1
4	110-32531	Base .....	1	-	-
4	110-32641	Base .....	-	1	-
4	110-32651	Base .....	-	-	1
5	300-36250	Bolt 3/8" NC x 1" + rondelle frein .....	4	4	4
6	130-53751	Orbit motor support .....	1	1	1
7	MLH-125	Hydraulic motor with cushion valve for tractor with pump approx. 6 to 10 GPM .....	opt.	-	-
7	MLH-250	Hydraulic motor with cushion valve for tractor with pump approx. 8 to 12 GPM .....	opt.	opt.	opt.
7	MLH-315	Hydraulic motor with cushion valve for tractor with pump more than 12 GPM .....	-	opt.	opt.
8	130-54731	Safety guard .....	1	-	-
8	130-54751	Safety guard .....	-	1	1
9	8369	Key for "Orbit motor" .....	1	1	1
10	300-36250	Bolt 3/8" NC x 1" lg + flat washer & nylon locknut .....	2	2	2
11	300-32280	Bolt 1/4" NC x 1 1/4" lg + lock washer .....	1	-	-
11	300-32220	Bolt 1/4" NC x 3/4" lg + lock washer .....	-	1	1
12	RS-1/16x08ORB	Kit of two unidirectionals restrictors .....	1	1	1
13	323-36160	Set screw 3/8" NC x 3/8" lg .....	2	2	2



# P.T.O. SHAFT # 6545 (T20)

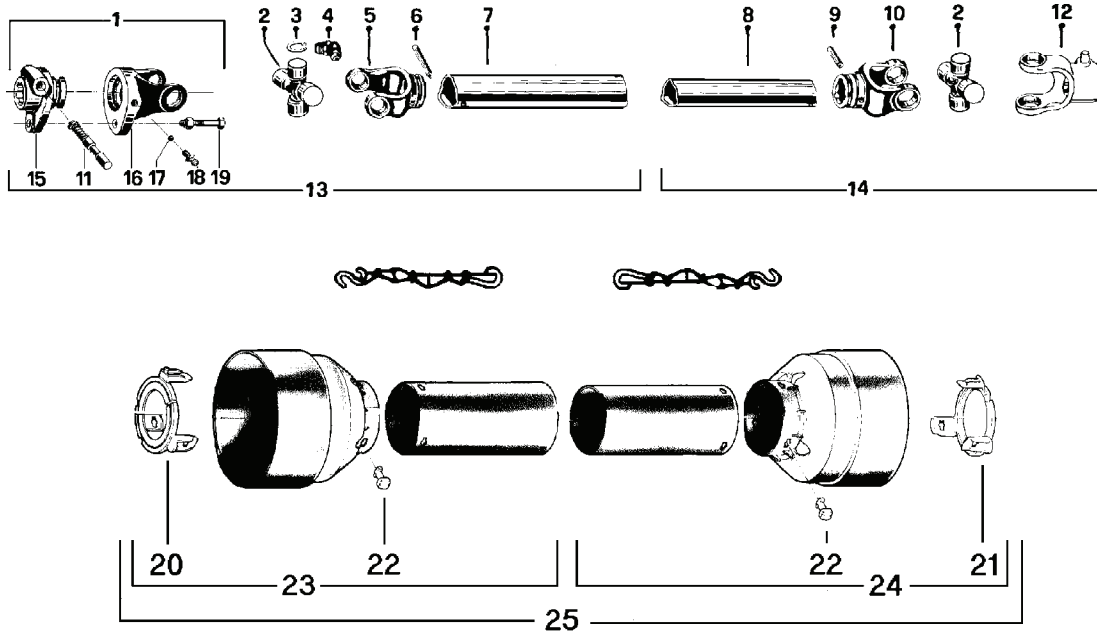

REF.	PART #	DESCRIPTION	QTY
1	6201	Quick disconnect yoke assembly .....	1
2	6208	U joint + 4 retaining ring + 1 grease fitting .....	2
3	6203	Retaining ring .....	8
4	8110	Grease fitting .....	2
5	6430	Yoke for outer tube .....	1
6	6344	Pin spring .....	1
7	6431	Outer tube .....	1
8	6432	Inner tube .....	1
9	6433	Pin spring .....	1
10	6434	Yoke for inner tube .....	1
11	8068-E	Yoke stopper 1 3/8" .....	1
12	6215	Yoke with round hole 1" .....	1
13	6435	P.T.O. section, side with safety shear bolt, outer part, without protector .....	1
14	6546	P.T.O. section, side without safety shear bolt, inner part, without protector .....	1
15	6202	Adaptor .....	1
16	6204	Yoke and shearplate .....	1
17	6205	Ball .....	17
18	6206	Grease fitting .....	1
19	6207	Safety shear bolt M6 x 40mm .....	1
20	6218-E	Bearing ring for outer guard tube .....	1
21	6219-E	Bearing ring for inner guard tube .....	1
22	8109	Stopper .....	6
23	6220	Outer shield .....	1
24	6221	Inner shield .....	1
25	6222	Complete shield .....	1
26	8308	Safety chain .....	2

# P.T.O. SHAFT # 6408-E (T20)

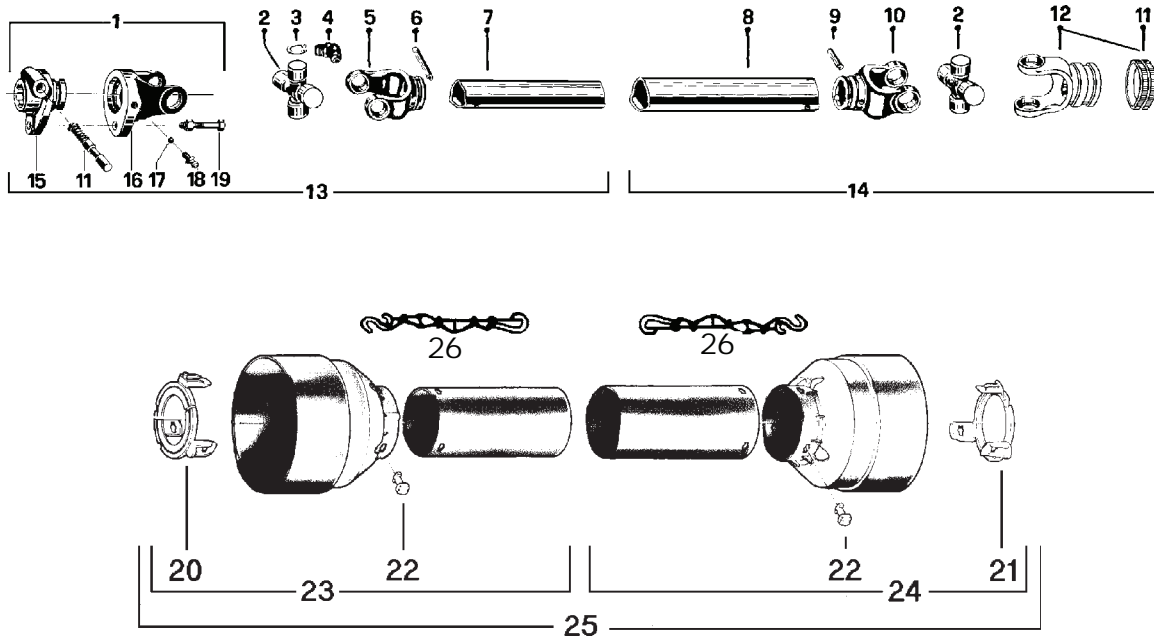

REF.	PART #	DESCRIPTION	QTY
1	6201	Quick disconnect shear yoke assembly .....	1
2	6208	U-joint + 4 retaining rings + 1 grease fitting .....	2
3	6203	Retaining ring .....	8
4	8110	Grease fitting .....	2
5	6434	Yoke for inner tube .....	1
6	6433	Stopper for inner tube .....	1
7	6432	Inner tube .....	1
8	6431	Outer tube .....	1
9	6344	Stopper for outer tube .....	1
10	6430	Yoke for outer tube .....	1
11	8363	Collar kit .....	2
12	6409	Yoke with hole 1 3/8"-6 splines + yoke stopper .....	1
13	6224	P.T.O. section, side with safety shear bolt, inner part, with protector .....	1
14	6225	P.T.O. section, side without safety shear bolt, outer part, with protector .....	1
15	6202	Adaptor .....	1
16	6204	Yoke and shearplate .....	1
17	6205	Ball .....	17
18	6206	Grease fitting .....	1
19	6207	Safety shear bolt M6 x 40mm .....	1
20	6219-E	Bearing ring for inner guard tube .....	1
21	6218-E	Bearing ring for outer guard tube .....	1
22	8109	Stopper .....	6
23	6221	Inner shield .....	1
24	6220	Outer shield .....	1
25	6222	Complete shield .....	1
26	8308	Safety chain .....	2

# P.T.O. SHAFT # 6248-EG (T40)

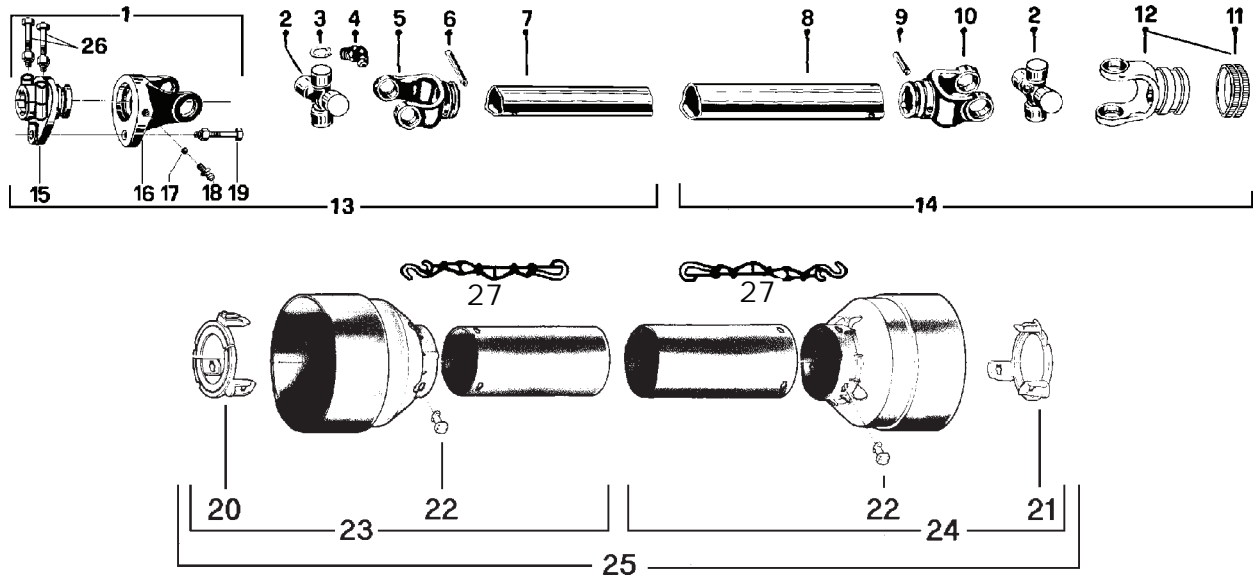

REF.	PART #	DESCRIPTION	QTY
1	6232-2	Safety shear yoke (2 bolts) .....	1
2	6239	U-joint + 4 retaining rings + 1 grease fitting .....	2
3	6234	Retaining ring .....	8
4	8110	Grease fitting .....	2
5	6353	Yoke for inner tube .....	1
6	6344	Stopper for inner tube .....	1
7	6343	Inner tube .....	1
8	6342	Outer tube .....	1
9	6341	Stopper for outer tube .....	1
10	6340	Yoke for outer tube .....	1
11	8363	Collar kit .....	1
12	6354	Yoke with hole 1 3/8"-6 splines + yoke stopper .....	1
13	6236	P.T.O. section, side with safety shear bolt, inner part, without protector .....	1
14	6237	P.T.O. section, side without safety shear bolt, outer part, without protector .....	1
15	6233-2	Adaptor (2 bolts) .....	1
16	6235	Yoke and shearplate .....	1
17	8070	Ball .....	17
18	8071	Grease fitting .....	1
19	6238	Safety shear bolt M8 x 50mm .....	1
20	6349-E	Bearing ring for inner guard tube .....	1
21	6348-E	Bearing ring for outer guard tube .....	1
22	8109	Stopper .....	6
23	6351	Inner shield .....	1
24	6350	Outer shield .....	1
25	6352	Complete shield .....	1
26	8222	Bolt M12 x 70mm .....	2
27	8308	Safety chain .....	2

# P.T.O. SHAFT # 8114-EG (T50)

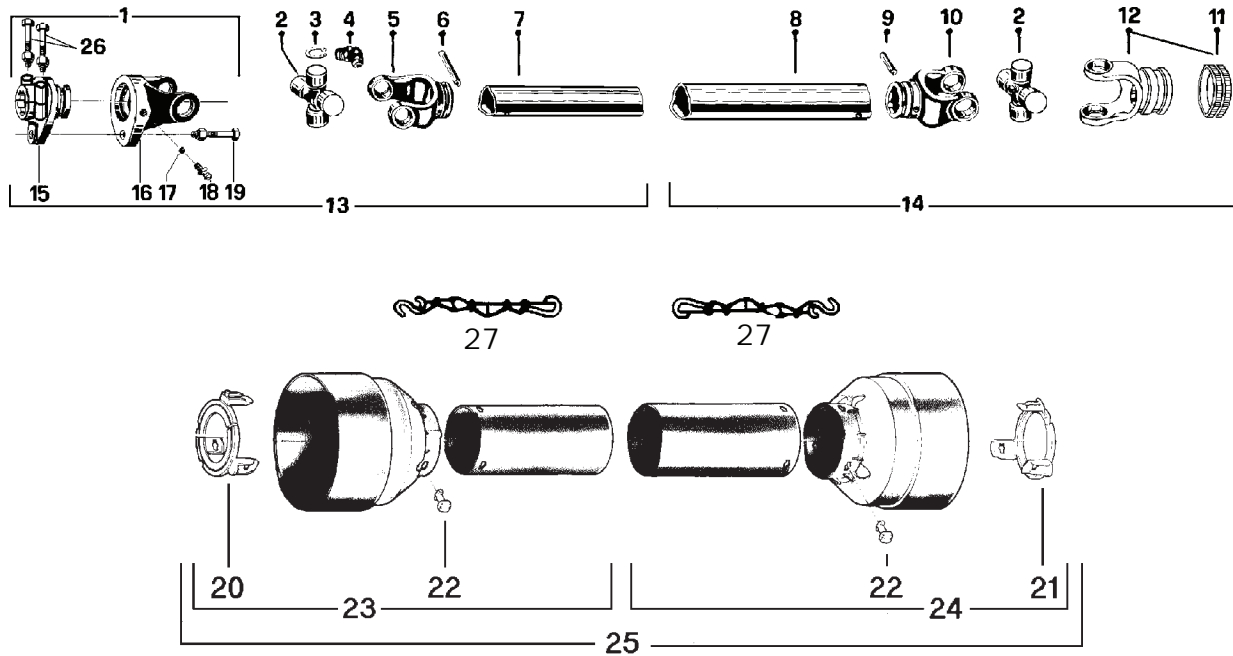

REF.	PART #	DESCRIPTION	QTY
1	8221	Safety shear yoke (2 bolts) .....	1
2	8073	U joint + 4 retaining ring + 1 grease fitting .....	2
3	8061	Retaining ring .....	8
4	8110	Grease fitting .....	2
5	8079	Yoke for inner tube .....	1
6	6341	Pin spring .....	1
7	8077	Inner tube .....	1
8	8076	Outer tube .....	1
9	8142	Pin spring .....	1
10	8074	Yoke for outer tube .....	1
11	8363	Collar kit .....	1
12	8113	Yoke with hole 1 3/8"-6 splines + yoke stopper (#11 included) .....	1
13	8235	P.T.O. section, side with safety shear bolt, inner part, without protector .....	1
14	8236	P.T.O. section, side without safety shear bolt, outer part, without protector .....	1
15	8223	Adaptor with 2 bolts .....	1
16	8069	Yoke and shearplate .....	1
17	8070	Ball .....	17
18	8071	Grease fitting .....	1
19	8072	Safety shear bolt M10 x 50mm .....	1
20	8084-E	Bearing ring for inner guard tube .....	1
21	8083-E	Bearing ring for outer guard tube .....	1
22	8109	Stopper .....	6
23	8086	Inner shield .....	1
24	8085	Outer shield .....	1
25	8087	Complete shield .....	1
26	8222	Bolt M12 x 70mm + lock nut .....	2
27	8308	Safety chain .....	2

# P.T.O. SHAFT # 8202 (T60)

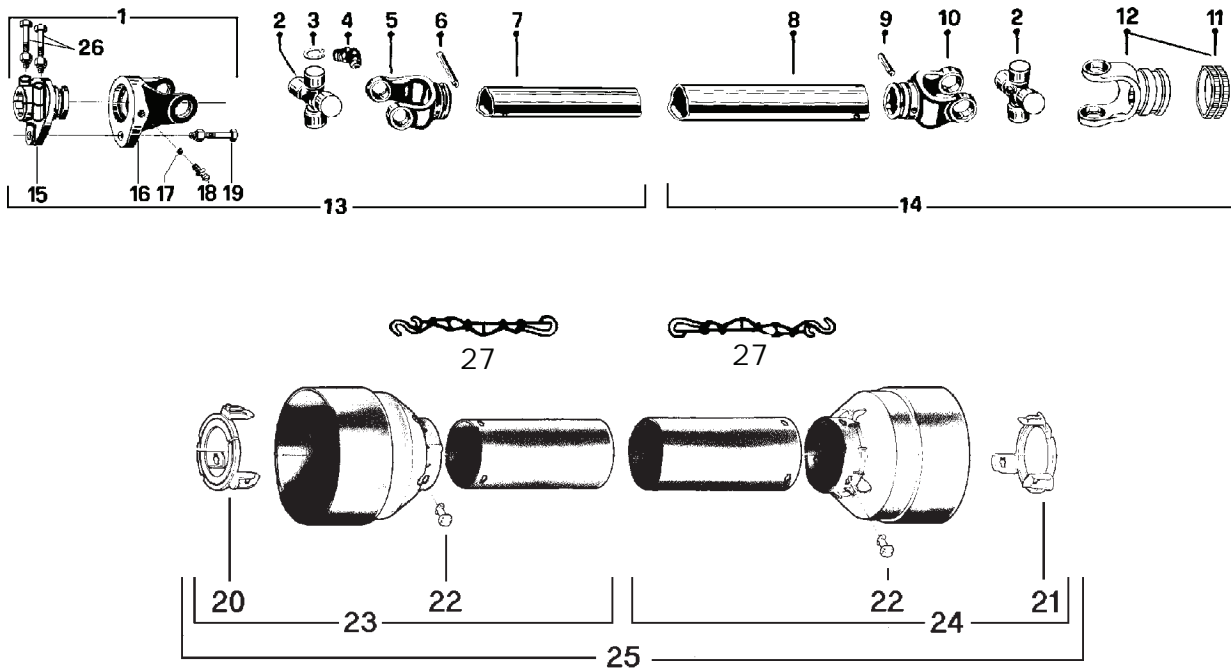

REF.	PART #	DESCRIPTION	QTY
1	8237	Safety shear yoke (2 bolts) .....	1
2	8238	U joint + 4 retaining ring + 1 grease fitting .....	2
3	8061	Retaining ring .....	8
4	8110	Grease fitting .....	2
5	8239	Yoke for inner tube .....	1
6	8075	Pin spring .....	1
7	8077	Inner tube .....	1
8	9212	Outer tube .....	1
9	9210-E	Pin spring .....	1
10	8240	Yoke for outer tube .....	1
11	8363	Collar kit .....	1
12	8250	Yoke with hole 1 3/8"-6 splines + yoke stopper (#11 included) .....	1
13	8241	P.T.O. section, side with safety shear bolt, inner part, without protector .....	1
14	8242	P.T.O. section, side without safety shear bolt, outer part, without protector .....	1
15	8243	Adaptor with 2 bolts .....	1
16	8244	Yoke and shearplate .....	1
17	9205	Ball .....	17
18	8071	Grease fitting .....	1
19	8218	Safety shear bolt M10 x 60mm .....	1
20	8245	Bearing ring for inner guard tube .....	1
21	8246	Bearing ring for outer guard tube .....	1
22	8109	Stopper .....	6
23	8247	Inner shield .....	1
24	8248	Outer shield .....	1
25	8249	Complete shield .....	1
26	8222	Bolt M12 x 70mm + lock nut .....	2
27	8308	Safety chain .....	2

# GEAR BOX # 6550

170-05561

Oil volume required: 0.4 liter.  
Use SAE 80W90 oil or equivalent.

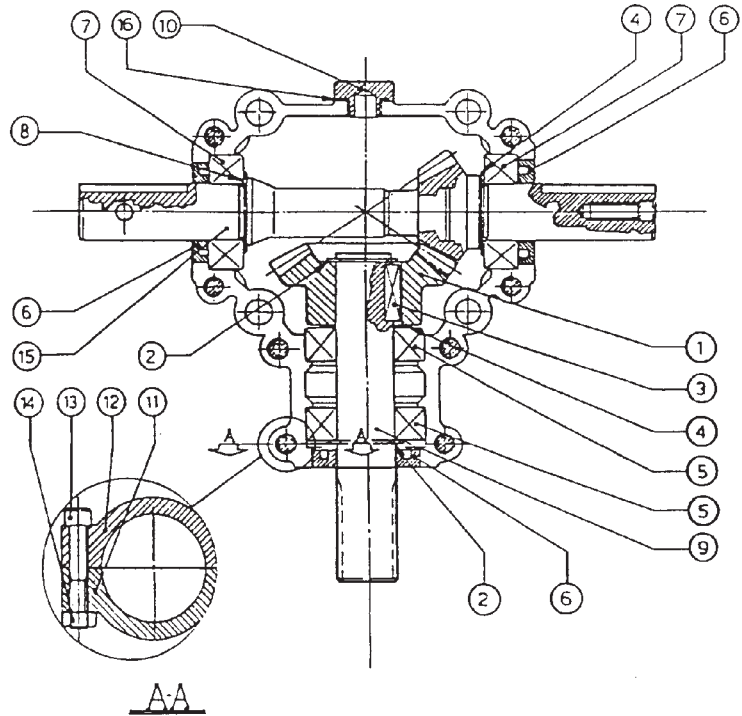
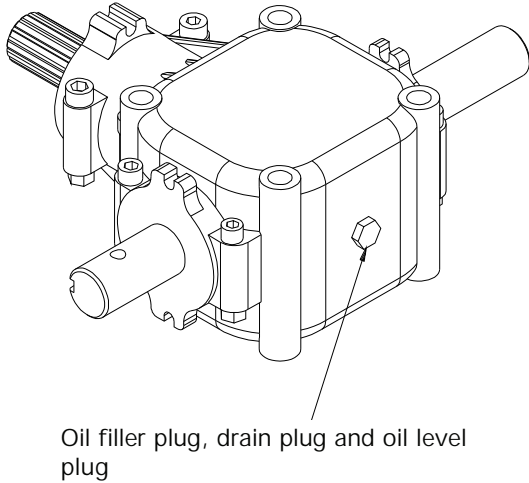

REF.	PART #	DESCRIPTION	QTY
1	6547	Gear Z24 .....	1
2	6548	Outside circlip .....	2
3	6549	Parallel key 8 x 7 x 25 .....	1
4	6562	Shim .....	2
5	6205-2RS	Bearing 6205 .....	2
6	6552	Oil seal .....	3
7	6205-2RSx1"	Bearing .....	2
8	6554	Shim .....	1
9	6555	Side shaft 1" - 15 splines .....	1
10	6556	Plug 3/8" GAS (oil filler plug, drain plug and oil level plug) .....	1
11	6557	Casing (lower) .....	1
12	6558	Casing (upper) .....	1
13	6559	Bolt M8 x 45 8,8 .....	8
14	6428	Hex. nut M8 8 .....	8
15	6560	Pinion shaft Z16 for impeller (1" & 1") .....	1
16	6425	O-ring OR-3062 .....	1

# GEAR BOX # 6451 (T281)

170-05571

Oil volume required: 0.5 liter.  
Use SAE 80W90 oil or equivalent.

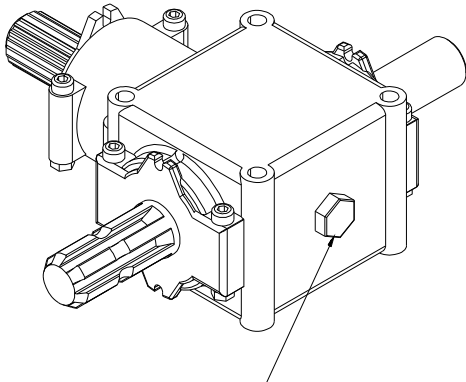

Oil filler plug, drain plug and oil level plug

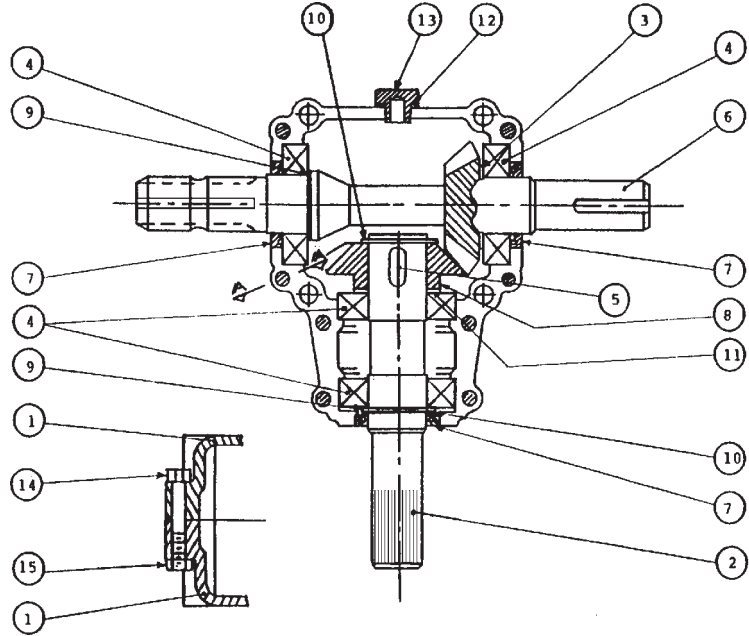

REF.	PART #	DESCRIPTION	QTY
1	6414	Casing .....	2
2	6429	Side shaft (1¼" - 19 splines) .....	1
3	6416	Spacer 35,3 x 48 .....	1
4	6207-2RS	Ball bearing .....	4
5	6418	Key 10 x 8 x 30 .....	1
6	6419	Impeller shaft (1¼" & 1 3/8" - 6 splines) .....	1
7	6420	Seal 35 x 52 x 7 .....	3
8	6421	Gear Z19 .....	1
9	6422	Spacer 35.3 x 0.5 .....	2
10	6423	Snap ring 35 UNI7435 .....	2
11	6424	Spacer 35.3 x 0.6 .....	1
12	6425	Oil seal .....	1
13	6426	Oil plug (oil filler plug, drain plug and oil level plug) .....	1
14	6427	Bolt M8 x 55 .....	8
15	6428	Nut M8 .....	8

# GEAR BOX # 8251 (T27D)

170-05581

Quantité d'huile requise: 1.2 litres  
Utilisez de l'huile SAE 80W90.

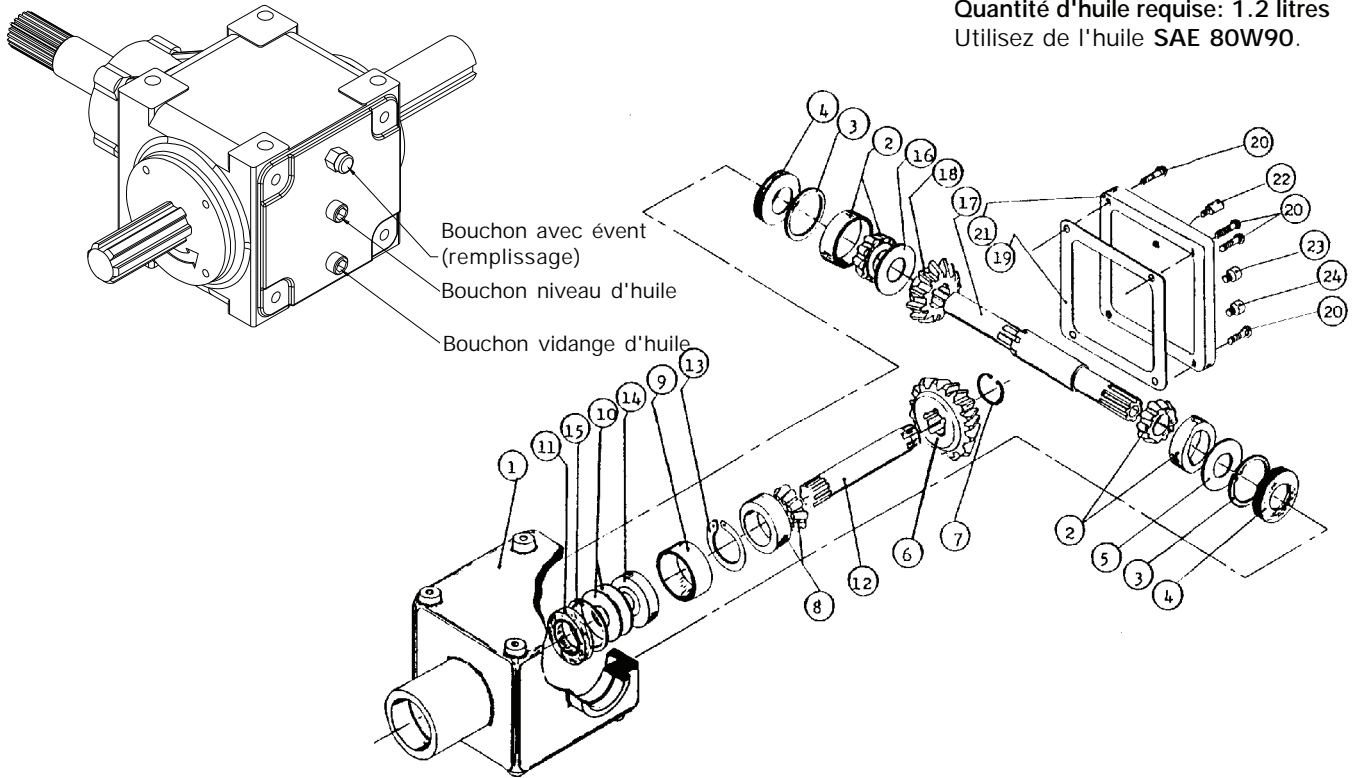

REF.	PART #	DESCRIPTION	QTY
1	8043	Casing .....	1
2	30208-A	Roller bearing .....	2
3	8045	Inside circlip 80mm .....	2
4	8046	Oil seal 40 x 80 x 12mm .....	2
5	8047	Adjusting washer .....	1
6	8048	Gear Z18 .....	1
7	8049	Outside circlip 40mm .....	1
8	30207-A	Roller bearing .....	1
9	8051	Spacer ring .....	1
10	8052	Adjusting washer .....	2
11	8053	Oil seal 35 x 72 x 12mm .....	1
12	8054	Side shaft (1¼" - 19 splines) .....	1
13	8055	Outside circlip 35mm .....	1
14	6207-2RS	Ball bearing .....	1
15	8057	Inside circlip 72mm .....	1
16	8058	Adjusting washer .....	1
17	8252	Impeller shaft (40 mm & 1 3/8" - 6 splines) .....	1
18	8060	Gear Z-18 .....	1
19	- - -	Use silicone caulking .....	-
20	8062	Bolt M10 x 14mm .....	4
21	8063	Cover .....	1
22	8065	Vent plug (oil filler plug) .....	1
23	8064	Plug (oil level plug) .....	1
24	8064	Plug (drain plug) .....	1



# CYLINDER 25TR04

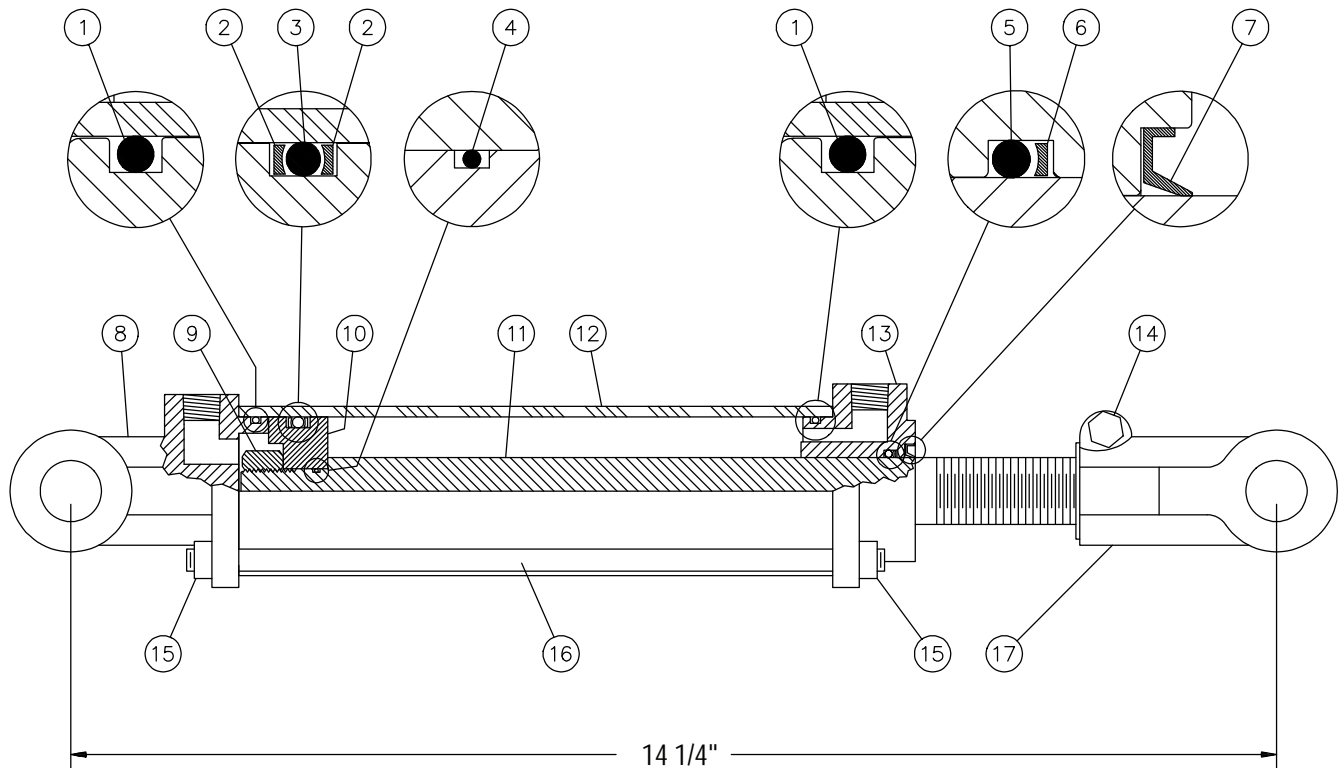

REF.	PART #	DESCRIPTION	QTY
1	See #RK25TR	O-ring 1/8" x 2 1/4" x 2 1/2" .....	2
2	See #RK25TR	Back-up 2 1/2" o.d. x 3/16 ø .....	2
3	See #RK25TR	O-ring 3/16" x 2 1/8" x 2 1/2" .....	1
4	See #RK25TR	O-ring 1/16" x 5/8" x 3/4" .....	1
5	See #RK25TR	O-ring 1/8" x 1 1/8" x 1 3/8" .....	1
6	See #RK25TR	Back-up 1 3/8" o.d. x 1/8" ø .....	1
7	See #RK25TR	Wiper 1 1/8" i.d. x 1 5/8" o.d. ....	1
8	492401	Yoke (for 2 1/2" tube) .....	1
9	338-46000	Nut 3/4" NF .....	1
10	4924-31	Piston 2 1/2" ø .....	1
11	491980-04	Piston rod 1 1/8" .....	1
12	491668-04	Cylinder body 2 1/2" ø .....	1
13	492421	Head (for 2 1/2" tube) .....	1
14	300-36355	Bolt 3/8" NC x 2 1/4" + nut .....	1
15	336-36000	Nut 3/8" NC .....	8
16	Std.	Threaded rod 3/8" NC x 8" lg .....	4
17	458599	Yoke (for 1 1/8" rod) .....	1
NI*	8183	Pin 1" ø + cotter pin .....	2
NI*	RK25TR	Repair kit for cylinder 2 1/2" (includes # 1, 2, 3, 4, 5, 6, & 7) .....	1

\*NI = NOT ILLUSTRATED

# CYLINDER 25TR08

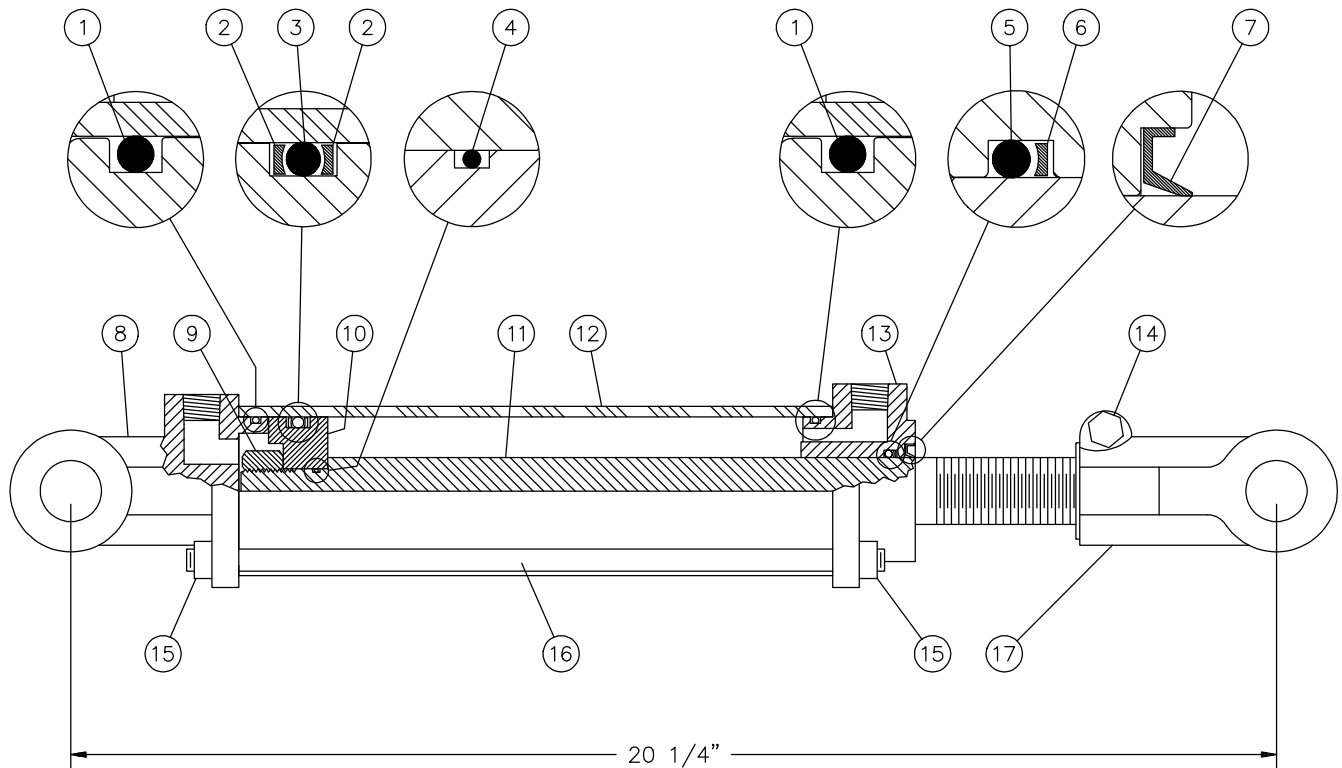

REF.	PART #	DESCRIPTION	QTY
1	See #RK25TR	O-ring 1/8" x 2 1/4" x 2 1/2" .....	2
2	See #RK25TR	Back-up 2 1/2" o.d. x 3/16 ø .....	2
3	See #RK25TR	O-ring 3/16" x 2 1/8" x 2 1/2" .....	1
4	See #RK25TR	O-ring 1/16" x 5/8" x 3/4" .....	1
5	See #RK25TR	O-ring 1/8" x 1 1/8" x 1 3/8" .....	1
6	See #RK25TR	Back-up 1 3/8" o.d. x 1/8" ø .....	1
7	See #RK25TR	Wiper 1 1/8" i.d. x 1 5/8" o.d. ....	1
8	492401	Yoke (for 2 1/2" tube) .....	1
9	338-46000	Nut 3/4" NF .....	1
10	4924-31	Piston 2 1/2" ø .....	1
11	491980	Piston rod 1 1/8" .....	1
12	491668	Cylinder body 2 1/2" ø .....	1
13	492421	Head (for 2 1/2" tube) .....	1
14	300-36355	Bolt 3/8" NC x 2 1/4" + nut .....	1
15	336-36000	Nut 3/8" NC .....	8
16	Std.	Threaded rod 3/8" NC x 12" lg .....	4
17	458599	Yoke (for 1 1/8" rod) .....	1
NI*	8183	Pin 1" ø + cotter pin .....	2
NI*	RK25TR	Repair kit for cylinder 2 1/2" (includes # 1, 2, 3, 4, 5, 6, & 7) .....	1

\*NI = NOT ILLUSTRATED

# HYDRAULIC MOTOR #MLH-125, MLH-250 & MLH-315



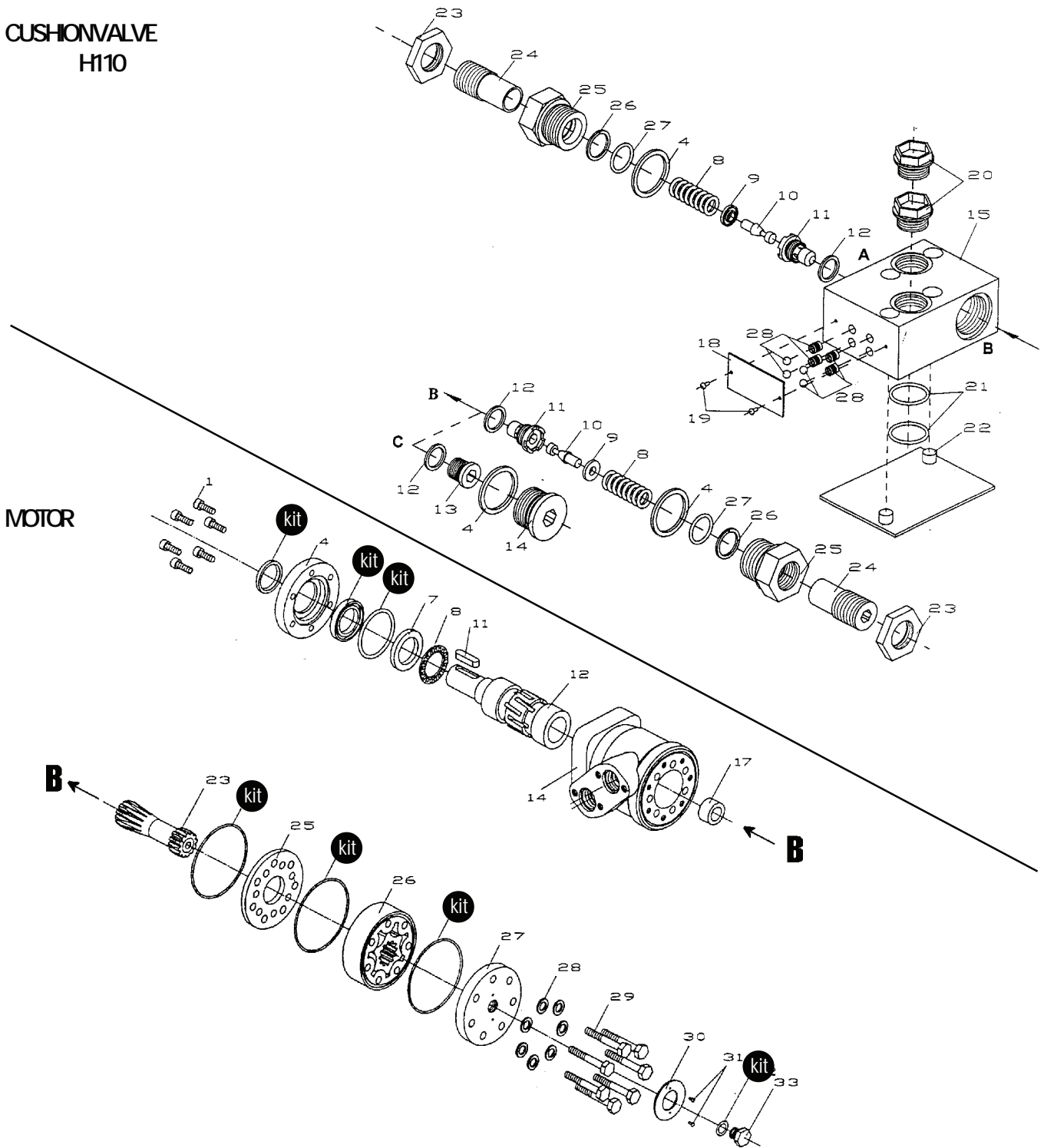



CUSHIONVALVE  
H110







REF.	PART #	DESCRIPTION	QTY
kit	8368	Set of seals.....	1
11	8369	Key for "Orbit" motor.....	1

# TORQUE CHART

## TORQUE SPECIFICATION TABLE

Thread UNC and UNF		Grade 2 				Grade 5   				Grade 8*   			
Bolt size		Torque				Torque				Torque			
Inches	mm	Pound feet min.	max.	Newton meters min.	max.	Pound feet min.	max.	Newton meters min.	max.	Pound feet min.	max.	Newton meters min.	max.
1/4	6.35	5	6	6.8	8.13	9	11	12.2	14.9	12	15	16.3	30.3
5/16	7.94	10	12	13.6	16.3	17	20.5	23.1	27.8	24	29	32.5	39.3
3/8	9.53	20	23	27.1	31.2	35	42	47.5	57.0	45	54	61.0	73.2
7/16	11.11	30	35	40.7	47.4	54	64	73.2	86.8	70	84	94.9	113.9
1/2	12.70	45	52	61.0	70.5	80	96	108.5	130.2	110	132	149.2	179.0
9/16	14.29	65	75	88.1	101.6	110	132	149.2	179.0	160	192	217.0	260.4
5/8	15.88	95	105	128.7	142.3	150	180	203.4	244.1	220	264	298.3	358.0
3/4	19.05	150	185	203.3	250.7	270	324	366.1	439.3	380	456	515.3	618.3
7/8	22.23	160	200	216.8	271.0	400	480	542.4	650.9	600	720	813.6	976.3
1	25.40	250	300	338.8	406.5	580	696	786.5	943.8	900	1080	1220.4	1464.5
1 1/8	25.58	-	-	-	-	800	880	1084.8	1193.3	1280	1440	1735.7	1952.6
1 1/4	31.75	-	-	-	-	1120	1240	1518.7	1681.4	1820	2000	2467.9	2712.0
1 3/8	34.93	-	-	-	-	1460	1680	1979.8	2278.1	2380	2720	3227.3	3688.3
1 1/2	38.10	-	-	-	-	1940	2200	2630.6	2983.2	3160	3560	4285.0	4827.4

\* Thick nuts must be used with grade 8 bolts.

Size of screw	Thread	Pitch (mm)	Grade 4T  				Grade 7T 				Grade 8T  			
			Torque				Torque				Torque			
			Pound feet min.	max.	Newton meters min.	max.	Pound feet min.	max.	Newton meters min.	max.	Pound feet min.	max.	Newton meters min.	max.
M6	UNC	1.00	3.6	5.8	4.9	7.9	5.8	9.4	7.9	12.7	7.2	10	9.8	13.6
M8	UNC	1.25	7.2	14	9.8	19	17	22	23	29.8	20	26	27.1	35.2
M10	UNC	1.5	20	25	27.1	33.9	34	40	46.1	54.2	38	46	51.5	62.3
M12	UNC	1.75	28	34	37.9	46.1	51	59	69.1	79.9	57	66	77.2	89.4
M14	UNC	2.0	49	56	66.4	75.9	81	93	109.8	126	96	109	130.1	147.7
M16	UNC	2.0	67	77	90.8	104.3	116	130	157.2	176.2	129	145	174.8	196.5
M18	UNC	2.0	88	100	119.2	136	150	168	203.3	227.6	175	194	237.1	262.9
M20	UNC	2.5	108	130	146.3	176.2	186	205	252	277.8	213	249	288.6	337.4
M8	UNF	1.0	12	17	16.3	23	19	27	25.7	36.6	22	31	29.8	42
M10	UNF	1.25	20	29	27.1	39.3	35	47	47.4	63.7	40	52	54.2	70.5
M12	UNF	1.25	31	41	42	55.6	56	68	75.9	92.1	62	75	84	101.6
M14	UNF	1.5	52	64	70.5	86.7	90	106	122	143.6	107	124	145	168
M16	UNF	1.5	69	83	93.5	112.5	120	138	162.6	187	140	158	189.7	214.1
M18	UNF	1.5	100	117	136	158.5	177	199	239.8	269.6	202	231	273.7	313
M20	UNF	1.5	132	150	178.9	203.3	206	242	279.1	327.9	246	289	333.3	391.6

Use the above torques when special torque is not given.

NOTE: These values apply to fasteners as received from supplier, dry, or when lubricated with normal engine oil. They do not apply if extreme pressure lubricants are used.

---

---

## **WARRANTY**

---

PRONOVOST warrants this product to the initial purchaser for the period of one year from the date of purchase against defects in materials and workmanship.

We will replace or repair defective parts free of charge if they are returned to our plant in St-Tite, Quebec, Canada.

Transportation charges are the responsibility of the customer. This warranty is not transferable.

Hydraulic cylinders are covered by the manufacturer of these items.

The PTO shafts are warranted by the manufacturer and cover **only** defects in material and workmanship, and is conditional to recommended use and installation only.

All PRONOVOST spare parts purchased are covered by a three (3) month warranty.

This warranty becomes void and nul if the equipment is modified, breaks down as the result of an accident, is not operated according to manufacturer's recommendations, damaged by negligence or if maintenance has not been carried out as specified.

Our obligation is limited to the replacement or repair of the defective part. PRONOVOST accepts no responsibility for direct or indirect consequential damages of any kind.





Ce manuel est aussi disponible en français.  
Veuillez téléphoner.



INNOVATION-EXCELLENCE

**LES MACHINERIES PRONOVOST INC.**  
260, Haut du Lac Sud (route 159),  
Saint-Tite, Quebec, Canada, G0X 3H0  
Tel.: (418) 365-7551, Fax: (418) 365-7954  
E-mail: [info@pronovost.qc.ca](mailto:info@pronovost.qc.ca)  
Website: [www.pronovost.qc.ca](http://www.pronovost.qc.ca)