

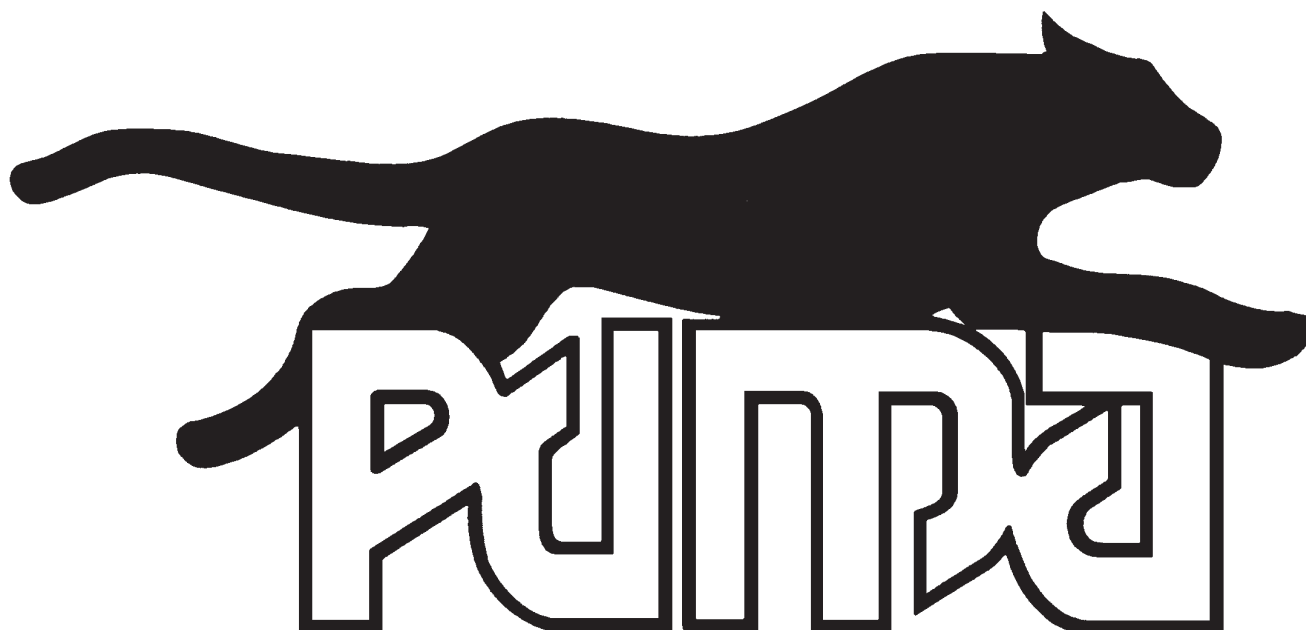

**OPERATOR'S / PARTS
MANUAL**



Snowblowers

Models

PUMA-54

PUMA-64

PUMA-72

PUMA-74

PUMA-84

PUMA-94



Copyright © Les Machineries Pronovost Inc., 2002

All rights reserved.
Printed in Canada.

TABLE OF CONTENTS

Section	Item	Page
1	Introduction	5
2	Safety	6
	General Safety	6
	Safety in operation	6
	Safety with Maintenance	7
	Safety in transport	7
	Safety in storage	7
3	Decals	8
	Safety Decals	8
	Maintenance Decals	9
4	Maintenance	10
5	Storage	11
6	Specifications	12
7	Parts List	13
	Snowblower PUMA-54 PUMA-64 PUMA-72	14
	Snowblower PUMA-74	16
	Snowblower PUMA-84 PUMA-94	18
	Manual Chute Kit MU-5464	20
	Manual Chute Kit MU-74 and MU-8494	21
	Hydraulic Chute Kit RHP-5464	22
	Hydraulic Chute Kit HP-74 and HP-8494	23
	P.T.O. Shaft 6545	24
	P.T.O. Shaft 8114	25
	P.T.O. Shaft 8202	26
	Gear Box 6550	27
	Gear Box 8251	28
	Cylinder 25TR04	29
	Cylinder 25TR08	30
8	Torque chart	31
9	Warranty	32

INTRODUCTION

Your Snowblower was carefully designed and we are confident it will meet your requirements in terms of quality, performance and reliability.

This manual was prepared to assist you in the safe operation of your new Snowblower. It contains important information which will help you achieve excellent returns with your Snowblower.

Please read this manual completely before operating your Snowblower and keep it for future reference.

Before starting the machine, you or any other person who will be operating the Snowblower must familiarize yourself with the safety recommendations and the operating instructions. Please read carefully and be sure to understand and follow all recommendations and procedures.

In this manual, the right and left sides are identified as shown on Figure 1.

If you require additional information on your Snowblower, please contact your PRONOVOST Dealer.

NOW take a moment to enter the model, serial number and the date of purchase of your Snowblower in the space provided.

When ordering parts from your Dealer, please refer to these numbers for a fast and efficient service. Use PRONOVOST parts for replacement.

The model and serial numbers are on the name plate shown on Fig. 1.

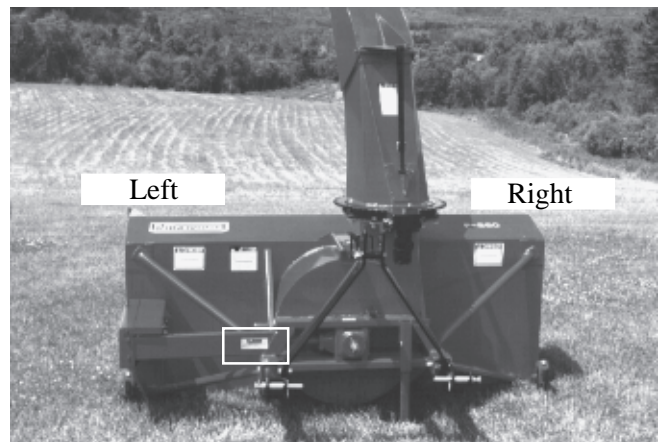

Figure 1

MODEL: _____ ✍

SERIAL NO.: _____ ✍

DATE OF PURCHASE: _____ ✍

SAFETY

GENERAL SAFETY

WHEN YOU SEE THIS SYMBOL



ATTENTION!

**BE ALERT
YOUR SAFETY IS INVOLVED**

This symbol «**SAFETY ALERT**» is used in this manual and on the safety decals on the Snowblower. It warns you of the possibility of danger. Carefully read, understand and follow all safety recommendations before operating the Snowblower.

- 1) Careful operation is the best assurance against accidents. Carefully read this manual and follow all recommendations before operating your Snowblower. It is the owner's responsibility to make sure that anyone who will operate the Snowblower will read this manual before operating the equipment.
- 2) Familiarize yourself with all controls and always be ready to stop the Snowblower quickly in case of emergency.
- 3) Never let a child operate the Snowblower.
- 4) Do not modify the Snowblower. Any non authorized modification may affect the efficiency and/or safety of the equipment.
- 5) Never operate the Snowblower with defective parts or if damaged in any way. Have it repaired before operating.
- 6) Make sure all fasteners are in place and properly secured or tightened. Refer to torque chart on page 31.
- 7) Avoid wearing loose fitting clothing when working with the Snowblower. These could get entangled in moving parts of the equipment and cause accidents.
- 8) Prolonged exposure to noise may hamper hearing.

Protect yourself by wearing adequate protection devices.

- 9) Hydraulic fluids under pressure can damage your skin. Do not use your hands to locate a leak.
- 10) Before the beginning of the snow season, inspect all areas where the Snowblower will be used and remove any object which may cause an accident and/or damage the equipment.
- 11) Never operate your Snowblower in poor visibility or without proper lighting conditions.

SAFETY IN OPERATION

- 1) Be sure there are no obstructions around the equipment and that no one stands near the equipment when in operation.
- 2) Do not operate an engine in a confined or non ventilated area.
- 3) Do not perform any adjustments, cleaning, maintenance or repairs with the engine running. The engine must be stopped and the P.T.O. disengaged. Preferably remove the key from the ignition.
- 4) Wear adequate clothing when working in cold or windy conditions.
- 5) Before operating, make sure the P.T.O. is properly installed and secured.
- 6) Before starting-up the Snowblower, make sure the auger and drum areas are free of ice.
- 7) Put P.T.O. control in neutral position before starting engine.
- 8) Keep hands, feet and clothing away from moving parts of the Snowblower. Stay away from the discharge chute.
- 9) Before unplugging the chute, always disengage the P.T.O., stop the engine and relieve all hydraulic pressures.

SAFETY (cont'd)

- 10) Do not operate in excessive inclined conditions. Be careful when turning in slopes.
- 11) Never operate your Snowblower with missing guards or without protective devices in place.
- 12) Do not operate your Snowblower near buildings, windows or other vehicles without prior and proper adjustment of the chute deflector.
- 13) Never aim discharge chute towards people or animals. This may cause serious injuries.
- 14) Always reduce operating speed in slippery conditions.
- 15) Be careful when backing-up, make sure you have good visibility.
- 16) Always be on the lookout for objects which may enter the Snowblower.
- 17) If undue vibrations are felt, disengage the P.T.O., stop the motor and look for the cause of the vibration. Vibration is usually the indication of a problem.
- 18) At the end of the operation, disengage the P.T.O., lower the Snowblower, put transmission in neutral, apply parking brake, stop engine and remove the key from the ignition.

SAFETY WITH MAINTENANCE

- 1) Perform the Snowblower maintenance according to recommendations contained in this manual.
- 2) Stop engine and relieve all hydraulic pressures before doing inspection, maintenance or repairs.
- 3) Never perform any work under the Snowblower while it is supported only by the tractor's hydraulic system. It must be completely supported by wooden blocks or other safe means.

SAFETY IN TRANSPORT

- 1) On public roads, use proper safety lights and check local regulations.
- 2) Be alert while driving on the road. Never carry passengers.
- 3) Always disengage P.T.O. while moving from one area of work to another.
- 4) The recommended road speed should be such as to maintain full control over steering and braking.
- 5) Be careful while backing up, make sure you have good visibility.

SAFETY IN STORAGE

- 1) Provide adequate supports to prevent any accidental overturning of the Snowblower.
- 2) Do not let children play in the area where the Snowblower is stored.

DECALS

SAFETY DECALS

The safety decals are affixed wherever special safety precautions are indicated. Locate them on the machine and read them carefully. If a decal is damaged, lost or illegible, install a new one. Each decal is shown and identified with a part number.

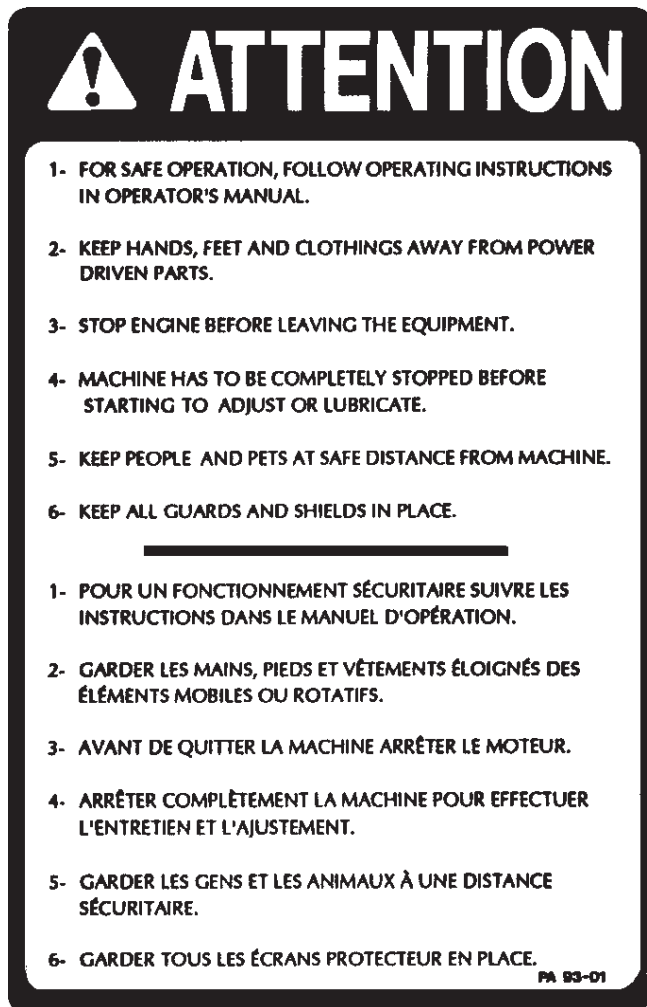

Figure 2
Part no.: A102

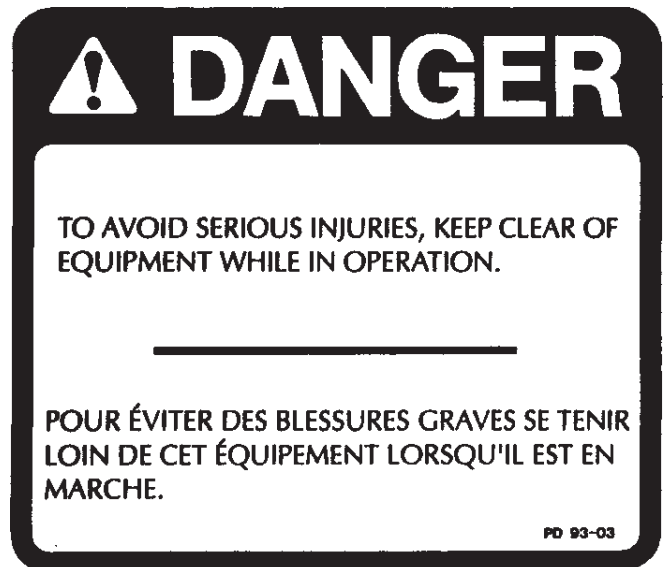

Figure 3
Part no.: A101

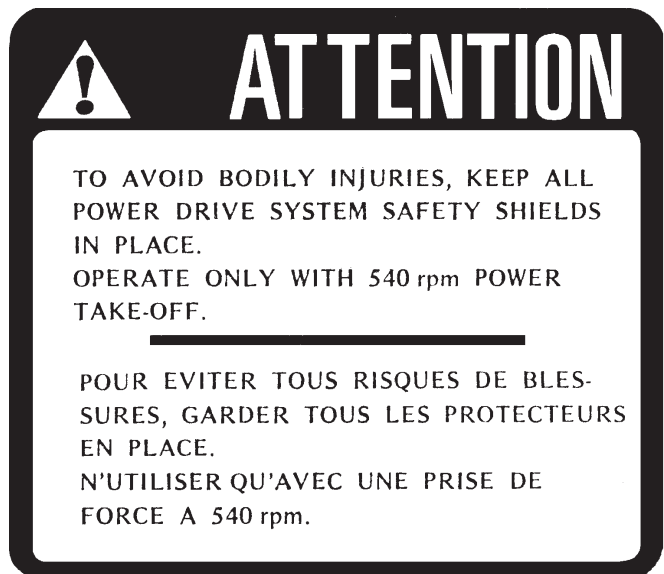

Figure 4
Part no.: A107

DECALS (cont'd)



Figure 5
Part no.: A108



Figure 6
Part no.: A 109

MAINTENANCE DECALS

The maintenance decals indicate the points requiring lubrication. Refer to maintenance section for more details.



Figure 7
Part no.: A104

MAINTENANCE

- 1) Wipe off all grease fittings with a clean cloth before adding grease in order to avoid injecting dirt and sand.
- 2) Repair or replace damaged grease fittings.
- 3) Lubricate all grease fittings every 10 hours of operation.
- 4) Oil drive chain every 8 hours of operation.
- 5) Lubricate P.T.O. shaft as indicated below:
 - 6) Check oil level in gear box once a month. If necessary add oil.
 - 7) Check tension of drive chain every 25 hours of operation and adjust if necessary.
 - 8) Check for tightness of bearing collars every 50 hours of operation.
 - 9) Change gearbox oil once a year. Use gear box oil S.A.E. W90 rated API, class GL-5.
 - 10) Check all nuts and bolts once a year. If necessary use torque chart on page 31.

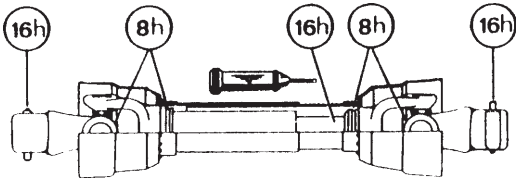

Pull out the P.T.O. and lubricate between the two tubes with low temperature grease.

STORAGE

- 1) Store the Snowblower in a cool, dry place.
- 2) Support the Snowblower with wooden blocks.
- 3) Keep all piston rods in the retracted position. This will assure better protection against the elements.
- 4) Clean your Snowblower.
- 5) Thoroughly inspect all parts of the Snowblower. Replace or repair worn or defective parts.
- 6) Touch-up or repaint if necessary.
- 7) Lubricate all points before storage.

SPECIFICATIONS

MODEL	PUMA-54	PUMA-64	PUMA-72	PUMA-74	PUMA-84	PUMA-94
Horse power recommended	16 - 25	18 - 25	18 - 25	25 - 40	40 - 75	50 - 75
Working width	54"	64"	72"	74"	84"	94"
Cutting height	24½"	24½"	24½"	29"	34"	34"
Impeller diameter	20"	20"	20"	22"	26"	26"
Depth of drum	6"	6"	6"	8"	11"	11"
Impeller blades	4	4	4	4	4	4
Size of impeller shaft	1"	1"	1"	1 9/16"	1 9/16"	1 9/16"
Impeller RPM	540	540	540	540	540	540
Main auger diameter	16"	16"	16"	16"	19"	19"
Drive chain	50	50	50	60	60	60
Hitch category	1	1	1	1 & 2	1 & 2	1 & 2
P.T.O. shaft	No. 2	No. 2	No. 2	No. 5	No. 5	No. 6
Chute rotation on UHMW	Standard	Standard	Standard	Standard	Standard	Standard
Adjustable skid shoes	Standard	Standard	Standard	Standard	Standard	Standard
Weight (lbs)	362	382	399	680	920	945

Design and specifications subject to change without notice.

PARTS LIST

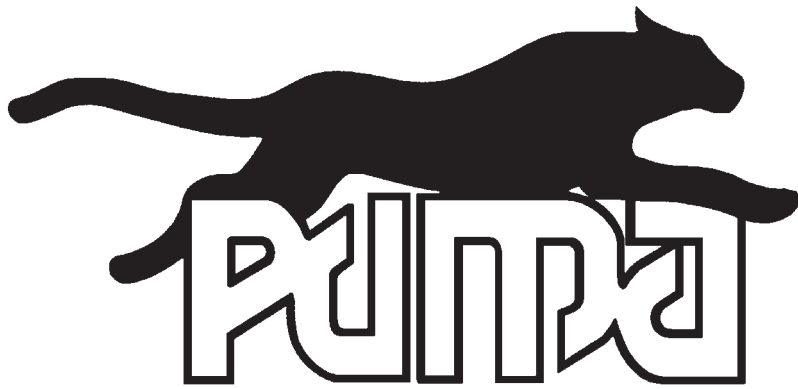

SNOWBLOWERS PUMA-54 PUMA-64 PUMA-72

170-02513

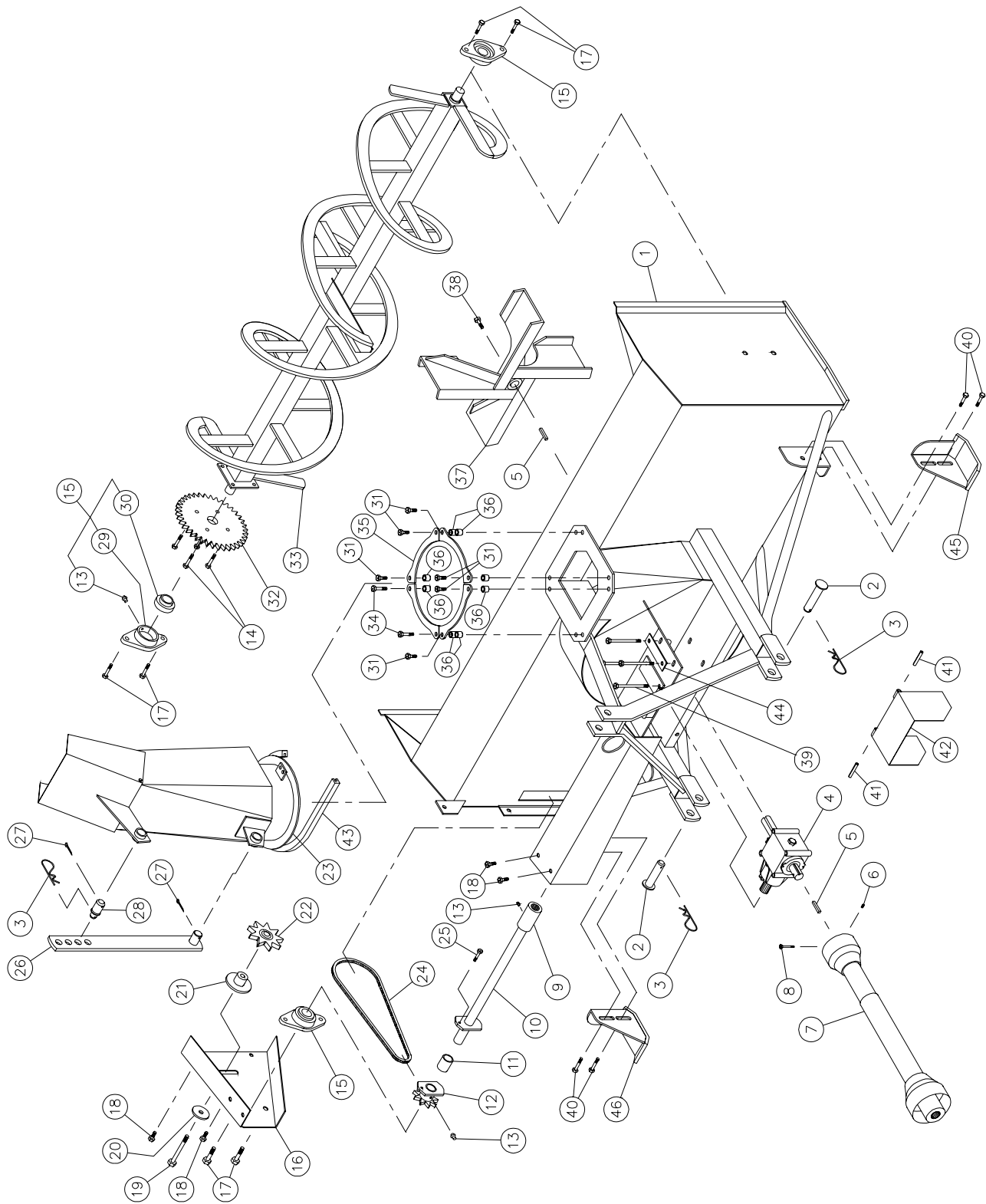

SNOWBLOWERS PUMA-54 PUMA-64 PUMA-72 (cont'd)

REF.	PART #	DESCRIPTION	54	64	72
			QTY		
1	120-00542	Frame 54"	1	-	-
1	120-00552	Frame 64"	-	1	-
1	120-02481	Frame 72"	-	-	1
2	110-03331	Pin category 1	2	2	2
3	Std.	Hitch pin clip 5/32"	3	3	3
4	6550	Gear box 1" ø x 1-15 splines	1	1	1
5	140-03871	Key 1/4" x 1/4" x 1 5/8" lg	2	2	2
6	323-32160	Hexagonal socket set screw 1/4"-20 x 3/8" lg	1	1	1
7	6545	P.T.O. shaft #2 - 1" ø x 1 3/8"-6	1	1	1
8	300-32370	Bolt 1/4" NC x 2 1/2" lg + nylon locknut	1	1	1
9	6565	Splined adaptor 1"-15	1	1	1
10	110-02821	Auger drive shaft 21" lg overall (including #9)	1	-	-
10	110-02971	Auger drive shaft 26" lg overall (including #9)	-	1	-
10	110-20981	Auger drive shaft 30" lg overall (including #9)	-	-	1
11	6566	Bushing 1" i.d. x 1 1/8" o.d. x 1 1/2" lg	1	1	1
12	6567	Sprocket # 50 + shearplate (including # 11 and # 13)	1	1	1
13	Std.	Grease fitting 1/4"-28 straighr	5	5	5
14	300-36280	Bolt 3/8" NC x 1 1/4" lg + two-way locknut	4	4	4
15	UCFLD205-16	Bearing 1"ø + flange	3	3	3
16	130-03301	Chain guard	1	1	1
17	300-40250	Bolt 1/2" NC x 1" lg + nylon locknut (thin)	6	6	6
18	300-36250	Bolt 3/8" NC x 1" lg + nylon locknut	4	4	4
19	300-40400	Bolt 1/2" NC x 3" lg + nylon locknut	1	1	1
20	378-40340	Flat washer 1/2" d.i. x 2" d.e.	1	1	1
21	110-07732	Idler	1	1	1
22	6604	Idler sprocket #50	1	1	1
23	110-02891	Chute	1	1	1
24	190-00501	Chain #50 x 50 1/2" lg	1	1	1
24	26A50	Connecting link #50	1	1	1
24	59-50	Offset link #50	1	1	1
25	Std.	Shear bolt 1/4" NC x 1" lg grade 2 + nylon locknut	1	1	1
26	110-02981	Chute adjusting bar	1	1	1
27	Std.	Cotter pin 5/32" x 1 1/2"	2	2	2
28	150-00641	Pin for chute adjusting bar	1	1	1
29	FLD205	Flange	3	3	3
30	UC205-16	Bearing 1" ø	3	3	3
31	300-36325	Bolt 3/8" NC x 1 3/4" lg + nylon locknut & flat washer	6	6	6
32	6288	Sprocket 50A36 T 1" ø	1	1	1
33	110-02941	Auger PUMA-54	1	-	-
33	110-02961	Auger PUMA-64	-	1	-
33	110-20991	Auger PUMA-72	-	-	1
34	300-36340	Bolt 3/8" NC x 2" lg + nylon locknut + flat washer	2	2	2
35	130-18391	Chute retaining bracket	4	4	4
36	160-07371	Spacer 11/16" o.d. x 7/16" i.d. x 5/8" lg	8	8	8
37	110-02871	Impeller 6" x 20" ø 4 blades T 1" ø	1	1	1
38	329-34280	Impeller cap screw 5/16" x 1 1/4" lg + lock washer	1	1	1
39	300-36520	Bolt 3/8" NC x 5" lg + nylon locknut	4	4	4
40	300-38280	Bolt 7/16" NC x 1 1/4" lg + nylon locknut + flat washer	4	4	4
41	Std.	Roll pin 5/16" x 2" lg	2	2	2
42	110-12681	Hinged P.T.O. shroud	1	1	1
43	190-04081	U-shaped UHMW 32 9/16" lg	1	1	1
44	140-11011	Back plate	3	3	3
45	110-15341	Skid shoe (right side)	1	1	1
46	110-15342	Skid shoe (left side)	1	1	1

SNOWBLOWERS PUMA-74

170-02523

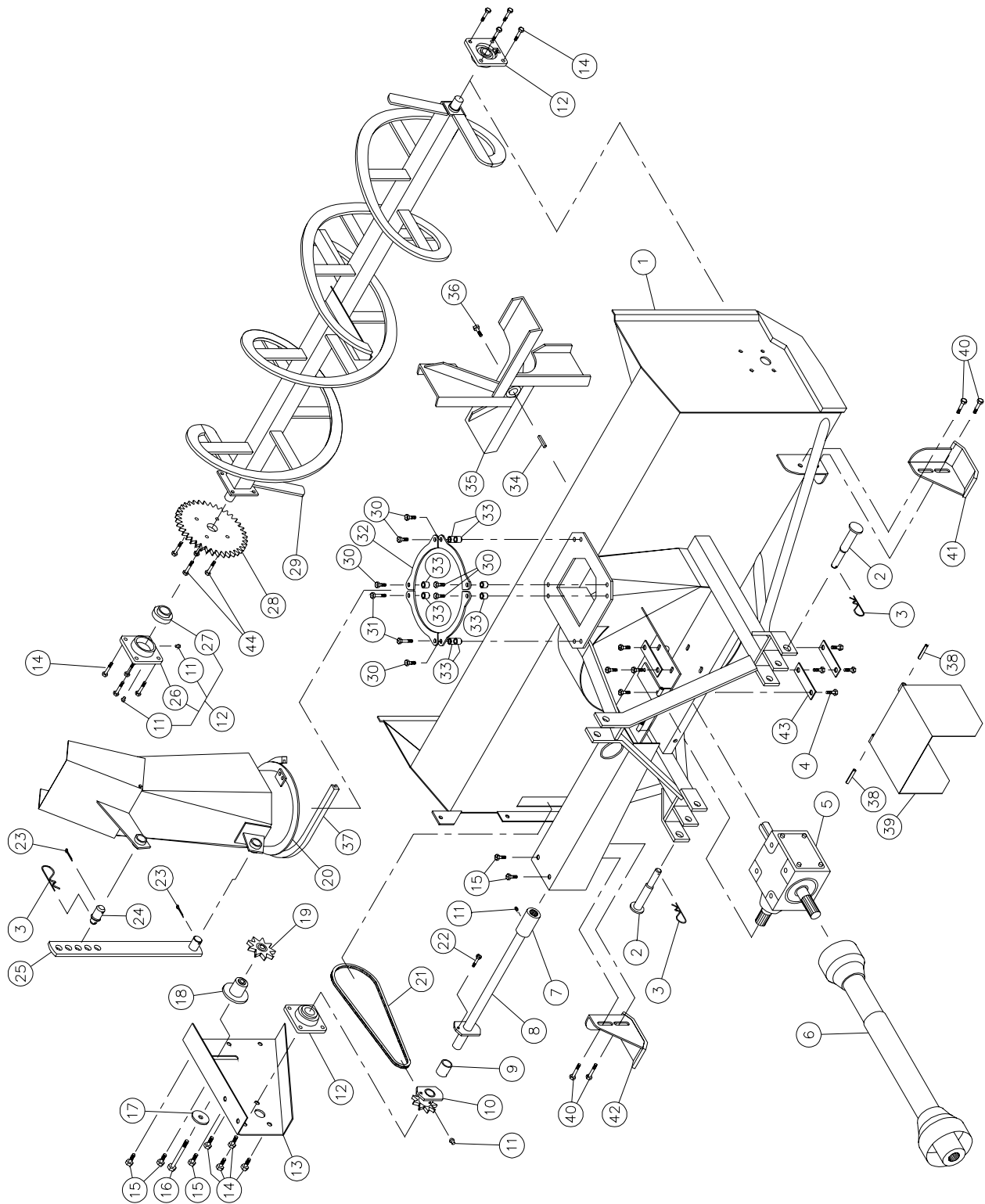

SNOWBLOWERS PUMA-74 (cont'd)

REF.	PART #	DESCRIPTION	QTY
1	120-00572	Frame 74"	1
2	110-03341	Pin category 1 & 2	2
3	Std.	Hitch pin clip 5/32"	3
4	300-40250	Bolt 1/2" NC x 1" lg + lock washer	8
5	8251	Gear box T27D	1
6	8114	P.T.O. shaft #5	1
7	6466	Splined adaptor 1 1/4"-19	1
8	110-03112	Auger drive shaft 26 1/8" lg overall (including #7)	1
9	6568	Bushing 1 1/4" i.d. x 1 7/16" o.d. x 2 1/2" lg	1
10	6570	Sprocket # 60 + shearplate (including #9 and #11)	1
11	Std.	Grease fitting 1/4"-28 straight	7
12	UCFD207-20	Bearing 1 1/4" ø + flange & 2 grease fittings (straight)	3
13	130-03611	Chain guard	1
14	300-38310	Bolt 7/16" NC x 1 1/2" lg + nylon locknut	12
15	300-38250	Bolt 7/16" NC x 1" lg + nylon locknut	5
16	300-40430	Bolt 1/2" NC x 3 1/2" lg + nylon locknut	1
17	378-40340	Flat washer 1/2" d.i. x 2" d.e.	1
18	110-07781	Idler	1
19	8186	Idler sprocket #60	1
20	110-03041	Chute	1
21	190-00551	Chain #60 x 63" lg	1
21	26A60	Connecting link #60	1
21	59-60	Offset link #60	1
22	Std.	Shear bolt 5/16" NC x 1 1/4" lg grade 2 + nylon locknut	1
23	Std.	Cotter pin 5/32" x 1 1/2"	2
24	150-00641	Pin for chute adjusting bar	1
25	110-02991	Chute adjusting bar	1
26	FD207	Flange for 2 grease fittings	3
27	UC207-20	Bearing 1 1/4" ø	3
28	8021	Sprocket 60A38 T 1 1/4" ø	1
29	110-03061	Auger PUMA-74	1
30	300-36340	Bolt 3/8" NC x 2" lg + nylon locknut & flat washer	6
31	300-36355	Bolt 3/8" NC x 2 1/4" lg + nylon locknut & flat washer	2
32	130-18441	Chute retaining bracket	4
33	160-07371	Spacer 1 1/16" o.d. x 7/16" i.d. x 5/8" lg	8
34	8030	Key 3/8" x 3/8" x 3 1/2" lg	1
35	110-03031	Impeller 8" x 22" ø 4 blades T 1 9/16" ø	1
36	329-44311	Impeller cap screw 5/8" x 1 1/2" lg + lock washer	1
37	190-04091	U-shaped UHMW x 38 7/8"	1
38	Std.	Roll pin 5/16" x 2" lg	2
39	110-12721	Hinged P.T.O. shroud	1
40	300-40310	Bolt 1/2" NC x 1 1/2" lg + nylon locknut + flat washer	4
41	110-15391	Skid shoe (right side)	1
42	110-15392	Skid shoe (left side)	1
43	140-11021	Back plate	3
44	300-38310	Bolt 7/16" NC x 1 1/2" lg + two-way locknut	4

SNOWBLOWERS PUMA-84 PUMA-94

170-02533

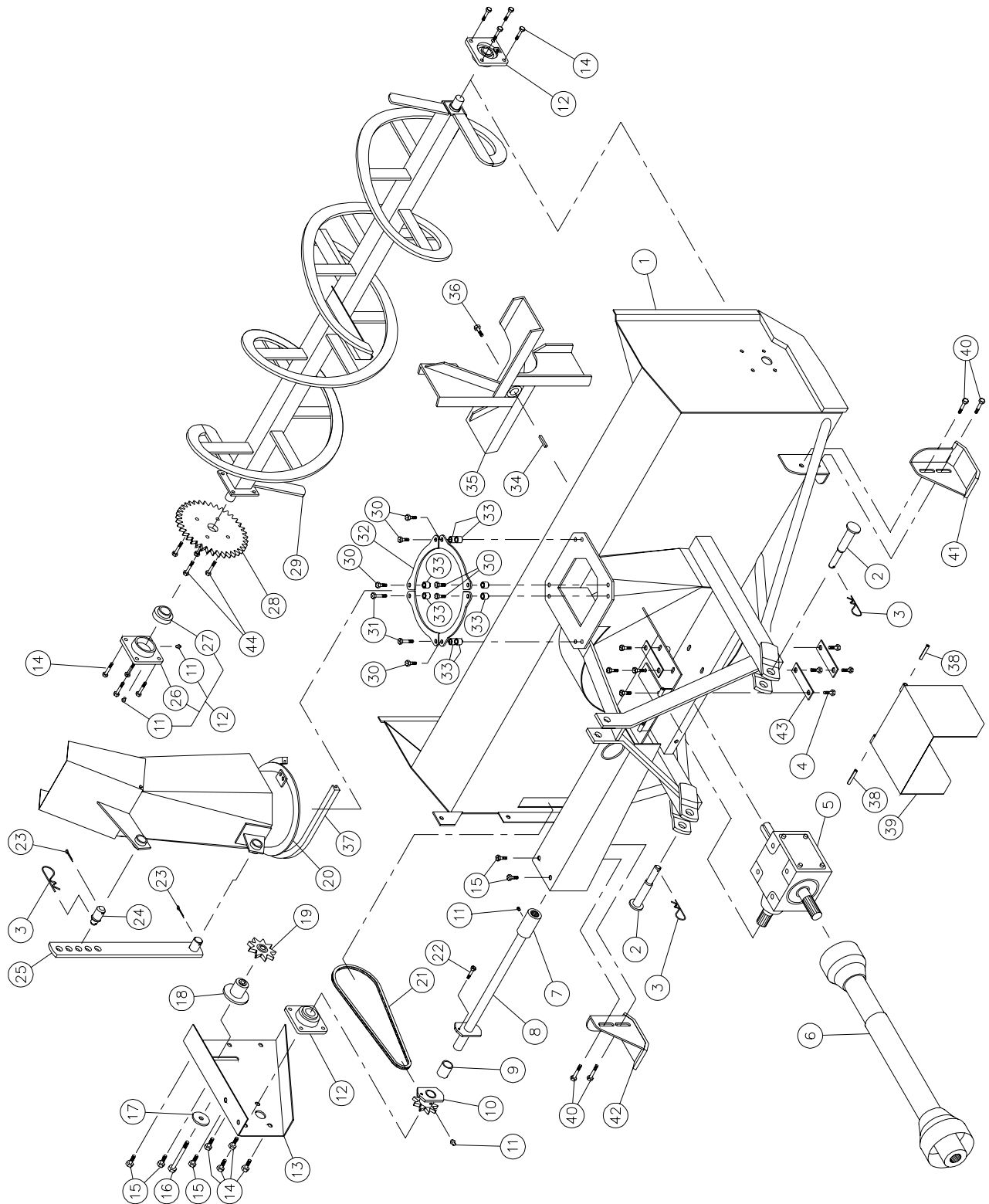

SNOWBLOWERS PUMA-84 PUMA-94 (cont'd)

REF.	PART #	DESCRIPTION	QTY	
			PUMA-84	PUMA-94
1	120-00603	Frame 84"	1	-
1	120-00813	Frame 94"	-	1
2	110-03341	Pin category 1 & 2	2	2
3	Std.	Hitch pin clip 5/32"	3	3
4	300-40250	Bolt 1/2" NC x 1" lg + lock washer	8	8
5	8251	Gear box T27D	1	1
6	8114	P.T.O. #5	1	-
6	8202	P.T.O. #6	-	1
7	6466	Splined adaptor 1 1/4"-19 (welded)	1	1
8	110-03352	Auger drive shaft 31 3/16" lg overall (including #7)	1	-
8	110-04282	Auger drive shaft 36 3/16" lg overall (including #7)	-	1
9	6568	Bushing 1 3/4" i.d. x 1 15/16" o.d. x 2 1/2" lg	1	1
10	6570	Sprocket # 60 + shearplate (including #9 and #11)	1	1
11	Std.	Grease fitting 1/4"-28 straight	7	7
12	UCFD207-20	Bearing 1 1/4" ø + flange & 2 grease fitting	3	3
13	130-04031	Chain guard	1	1
14	300-38310	Bolt 7/16" NC x 1 1/2" lg + nylon locknut	12	12
15	300-38250	Bolt 7/16" NC x 1" lg + nylon locknut	5	5
16	300-40430	Bolt 1/2" NC x 3 1/2" lg + nylon locknut	1	1
17	378-40340	Flat washer 1/2" d.i. x 2" d.e.	1	1
18	110-07781	Idler	1	1
19	8186	Idler sprocket #60	1	1
20	110-03171	Chute 84-94	1	1
21	190-00581	Chain #60 x 70 3/8" lg	1	1
21	26A60	Connecting link #60	1	1
21	59-60	Offset link #60	1	1
22	Std.	Shear bolt 5/16" NC x 1 1/4" lg grade 2 + nylon locknut	1	1
23	Std.	Cotter pin 5/32" x 1 1/2"	2	2
24	150-00641	Pin for chute adjusting bar	1	1
25	110-02991	Chute adjusting bar	1	1
26	FD207	Flange for 2 grease fitting	3	3
27	UC207-20	Bearing 1 1/4" ø	3	3
28	8021	Sprocket 60A38 T 1 1/4" ø	1	1
29	110-03211	Auger PUMA-84	1	-
29	110-04271	Auger PUMA-94	-	1
30	300-38340	Bolt 7/16" NC x 2" lg + nylon locknut & flat washer	6	6
31	300-38350	Bolt 7/16" NC x 2 1/4" lg + nylon locknut & flat washer	2	2
32	130-18451	Chute retaining bracket	4	4
33	160-07401	Spacer 1 1/16" o.d. x 1/2" i.d. x 5/8" lg	8	8
34	8030	Key 3/8" x 3/8" x 3 1/2" lg	1	1
35	110-03201	Impeller 11" x 26" ø 4 blades T 1 9/16" ø	1	1
36	329-44311	Impeller cap screw 5/16" x 1 1/2" lg + lock washer	1	1
37	190-04101	U-shaped UHMW x 51 7/16"	1	1
38	Std.	Roll pin 5/16" x 2" lg	2	2
39	110-12721	Hinged P.T.O. shroud	1	1
40	300-40310	Bolt 1/2" x 1 1/2" lg + nylon locknut + flat washer	4	4
41	110-15391	Skid shoe (right side)	1	1
42	110-15392	Skid shoe (left side)	1	1
43	140-11021	Back plate	3	3
44	300-38310	Bolt 7/16" NC x 1 1/2" lg + two-way locknut	4	4

MANUAL CHUTE KIT MU-5464

170-00473

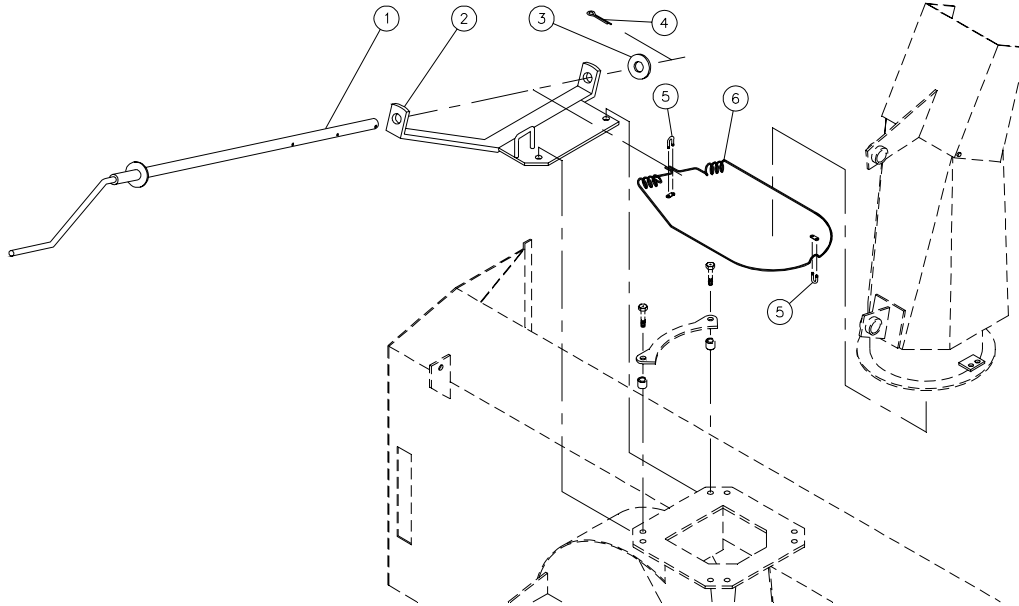

REF.	PART #	DESCRIPTION	QTY
1	110-02951	Crank	1
2	110-02851	Crank support	1
3	8206	Flat washer 1 3/8" i.d.	1
4	Std.	Cotter pin 5/32" x 1 1/2" lg	1
5	6303	Cable clamp 1/8"	2
6	190-00491	Cable 1/8" x 66" lg	1

MANUAL CHUTE KIT MU-74 AND MU-8494

170-00503

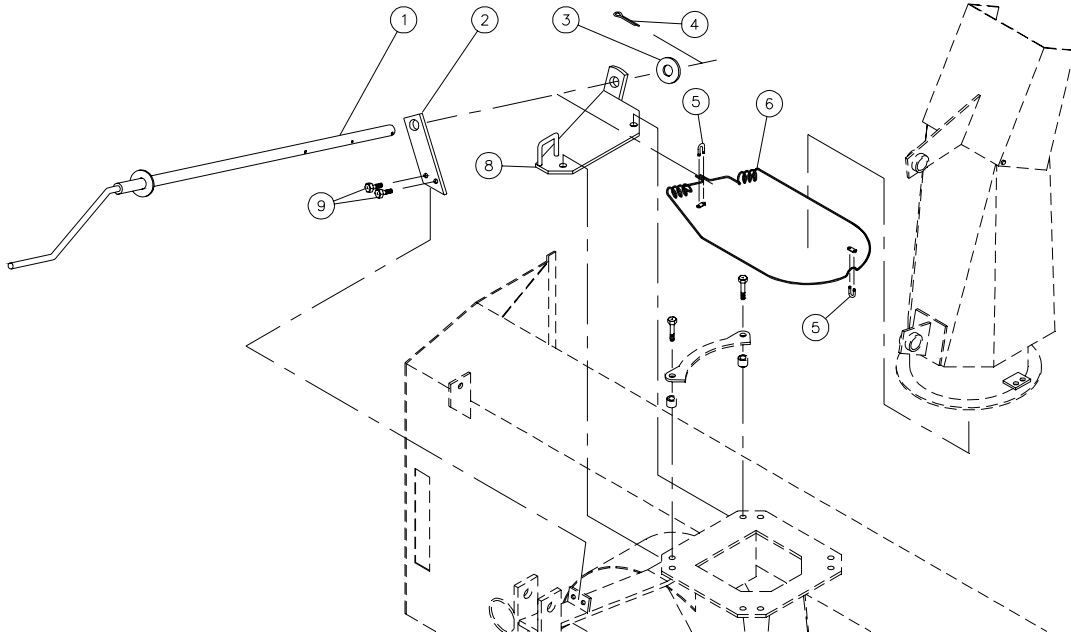

REF.	PART #	DESCRIPTION	QTY	
			74	84-94
1	110-05771	Crank	1	-
1	110-03251	Crank	-	1
2	130-27641	Crank support	1	-
2	130-27651	Crank support	-	1
3	8206	Flat washer 1 3/8" i.d.	1	1
4	Std.	Cotter pin 5/32" x 1 1/2" lg	1	1
5	6303	Cable clamp 1/8"	2	2
6	190-00521	Cable 1/8" x 108" lg	1	-
6	190-00561	Cable 1/8" x 114" lg	-	1
8	110-03101	Crank support	1	-
8	110-03241	Crank support	-	1
9	300-36250	Bolt 3/8" NC x 1" lg + nylon locknut	2	2

HYDRAULIC CHUTE KIT RHP-5464

170-02541

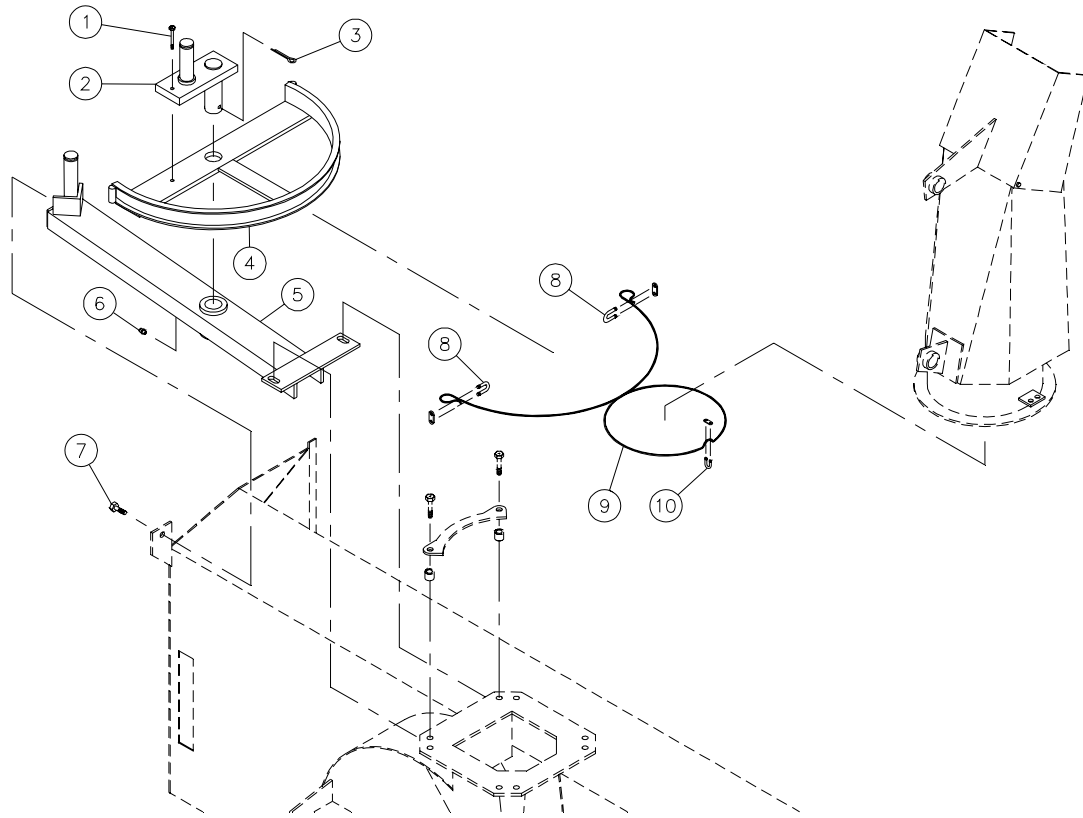

REF.	PART #	DESCRIPTION	QTY
1	Std.	Bolt 1/4" NC x 1 1/2" lg grade 5 + nylon locknut	1
2	110-04302	Pivot	1
3	Std.	Cotter pin 1/4" x 2"	1
4	110-02862	Arc	1
5	110-04291	Frame	1
6	Std.	Grease fitting 1/4"-28 straight	1
7	300-36250	Bolt 3/8" NC x 1" lg + nylon locknut	1
8	6496	Cable clamp 3/16"	2
9	190-00531	Cable 3/16" x 72" lg	1
10	6303	Cable clamp 1/8"	1

HYDRAULIC CHUTE KIT HP-74 AND HP-8494

170-02551

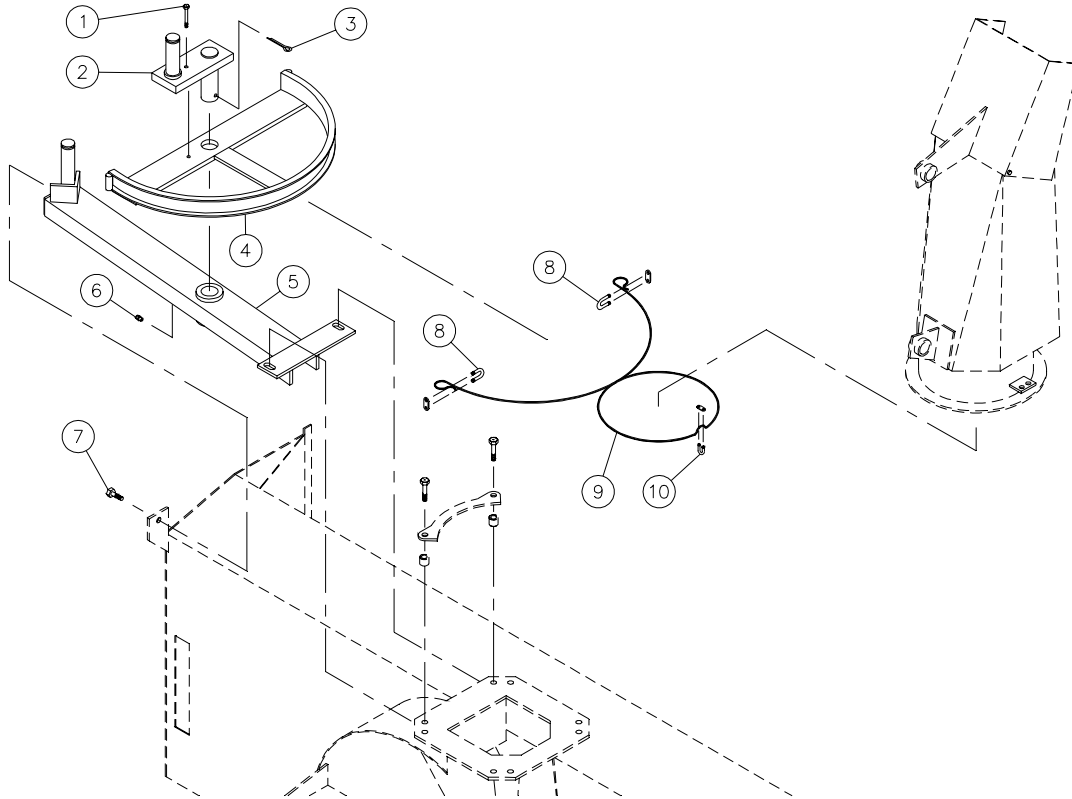

REF.	PART #	DESCRIPTION	QTY	
			74	84-94
1	300-32325	Bolt 1/4" NC x 1 3/4" lg grade 5 + nylon locknut	1	1
2	110-04152	Pivot	1	1
3	Std.	Cotter pin 1/4" x 2"	1	1
4	110-03082	Arc	1	-
4	110-03232	Arc	-	1
5	110-04173	Frame	1	-
5	110-04163	Frame	-	1
6	Std.	Grease fitting 1/4"-28 straight	1	1
7	300-36250	Bolt 3/8" NC x 1" lg + nylon locknut	1	1
8	6496	Cable clamp 3/16"	2	2
9	190-00541	Cable 3/16" x 85" lg	1	-
9	190-00571	Cable 3/16" x 96" lg	-	1
10	6303	Cable clamp 1/8"	1	1

P.T.O. SHAFT # 6545 (T20)

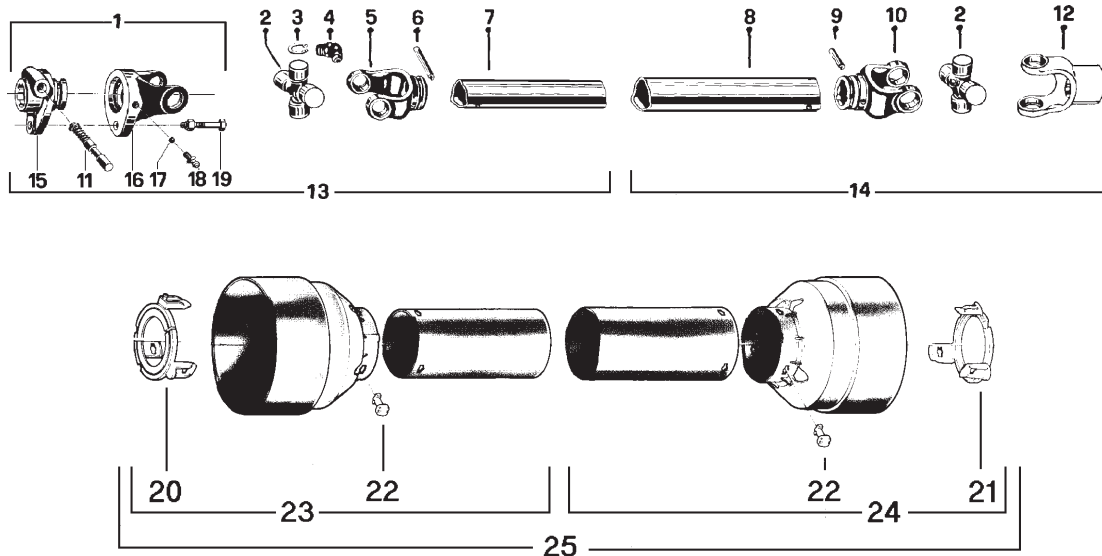

REF.	PART #	DESCRIPTION	QTY
1	6201	Quick disconnect yoke assembly	1
2	6208	U joint + 4 retaining ring + 1 grease fitting	2
3	6203	Retaining ring	8
4	8110	Grease fitting	2
5	6434	Yoke for inner tube	1
6	6433	Pin spring	1
7	6432	Inner tube	1
8	6431	Outer tube	1
9	6344	Pin spring	1
10	6430	Yoke for outer tube	1
11	8068-E	Yoke stopper 1 3/8"	1
12	6215	Yoke with round hole 1"	1
13	6224	P.T.O. section, side with safety shear bolt, inner part, without protector	1
14	6546	P.T.O. section, side without safety shear bolt, outer part, without protector	1
15	6202	Adaptor	1
16	6204	Yoke and shearplate	1
17	6205	Ball	17
18	6206	Grease fitting	1
19	6207	Safety shear bolt M6 x 40mm	1
20	6219-E	Bearing ring for inner guard tube	1
21	6218-E	Bearing ring for outer guard tube	1
22	8109	Stopper	6
23	6221	Inner shield	1
24	6220	Outer shield	1
25	6222	Complete shield	1

P.T.O. SHAFT # 8114-EG (T50)

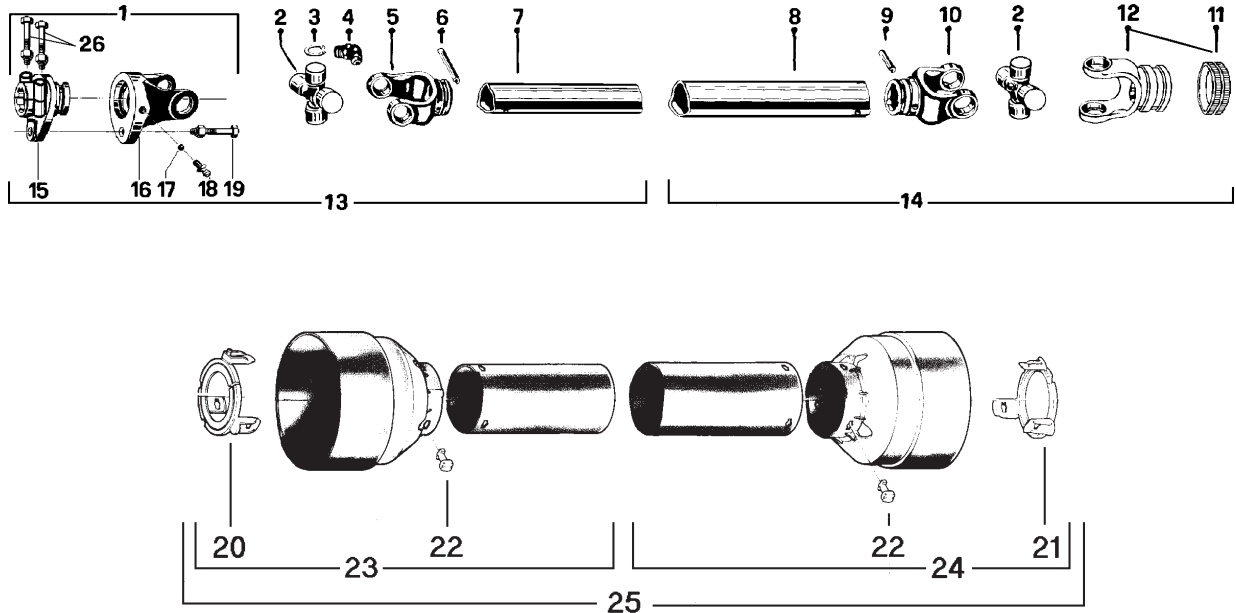

REF.	PART #	DESCRIPTION	QTY
1	8221	Safety shear yoke (2 bolts)	1
2	8073	U joint + 4 retaining ring + 1 grease fitting	2
3	8061	Retaining ring	8
4	8110	Grease fitting	2
5	8079	Yoke for inner tube	1
6	6341	Pin spring	1
7	8077	Inner tube	1
8	8076	Outer tube	1
9	8142	Pin spring	1
10	8074	Yoke for outer tube	1
11	8363	Collar kit	1
12	8113	Yoke with hole 1 3/8"-6 splines + yoke stopper (#11 included)	1
13	8235	P.T.O. section, side with safety shear bolt, inner part, without protector	1
14	8236	P.T.O. section, side without safety shear bolt, outer part, without protector	1
15	8223	Adaptor with 2 bolts	1
16	8069	Yoke and shearplate	1
17	8070	Ball	17
18	8071	Grease fitting	1
19	8072	Safety shear bolt M10 x 50mm	1
20	8084-E	Bearing ring for inner guard tube	1
21	8083-E	Bearing ring for outer guard tube	1
22	8109	Stopper	6
23	8086	Inner shield	1
24	8085	Outer shield	1
25	8087	Complete shield	1
26	8222	Bolt M12 x 70mm + lock nut	2

P.T.O. SHAFT # 8202

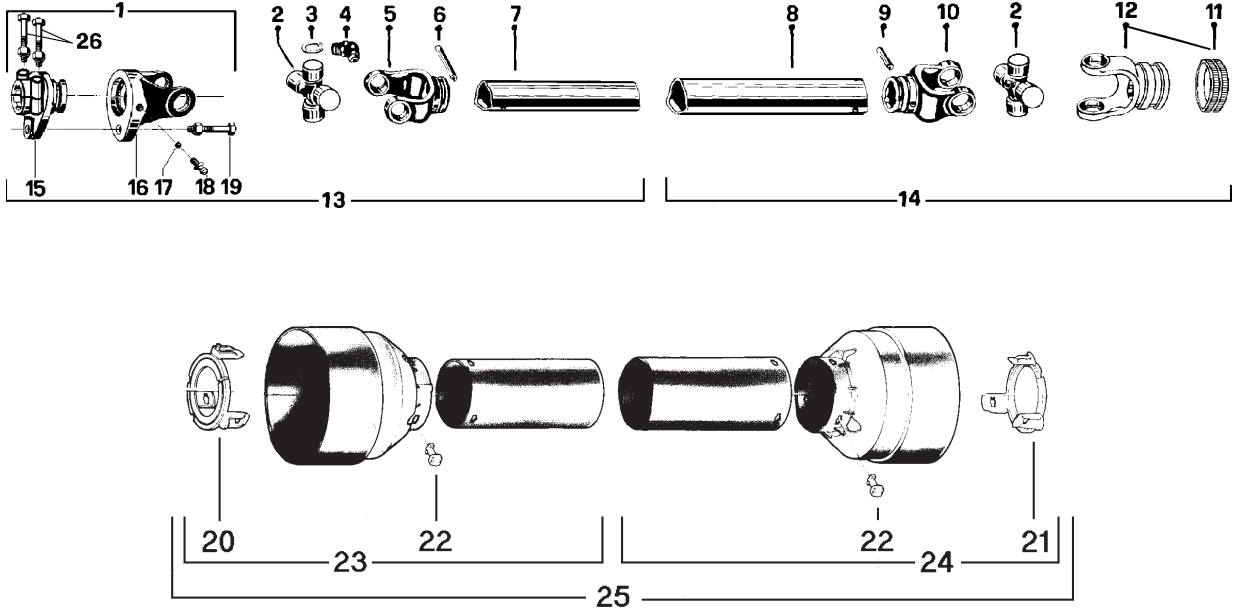

REF.	PART #	DESCRIPTION	QTY
1	8237	Safety shear yoke (2 bolts)	1
2	8238	U joint + 4 retaining ring + 1 grease fitting	2
3	8061	Retaining ring	8
4	8110	Grease fitting	2
5	8239	Yoke for inner tube	1
6	8075	Pin spring	1
7	8077	Inner tube	1
8	9212	Outer tube	1
9	9210-E	Pin spring	1
10	8240	Yoke for outer tube	1
11	8363	Collar kit	1
12	8250	Yoke with hole 1 3/8"-6 splines + yoke stopper (#11 included)	1
13	8241	P.T.O. section, side with safety shear bolt, inner part, without protector	1
14	8242	P.T.O. section, side without safety shear bolt, outer part, without protector	1
15	8243	Adaptor with 2 bolts	1
16	8244	Yoke and shearplate	1
17	9205	Ball	17
18	8071	Grease fitting	1
19	8218	Safety shear bolt M10 x 60mm	1
20	8245	Bearing ring for inner guard tube	1
21	8246	Bearing ring for outer guard tube	1
22	8109	Stopper	6
23	8247	Inner shield	1
24	8248	Outer shield	1
25	8249	Complete shield	1
26	8222	Bolt M12 x 70mm + lock nut	2

GEAR BOX # 6550

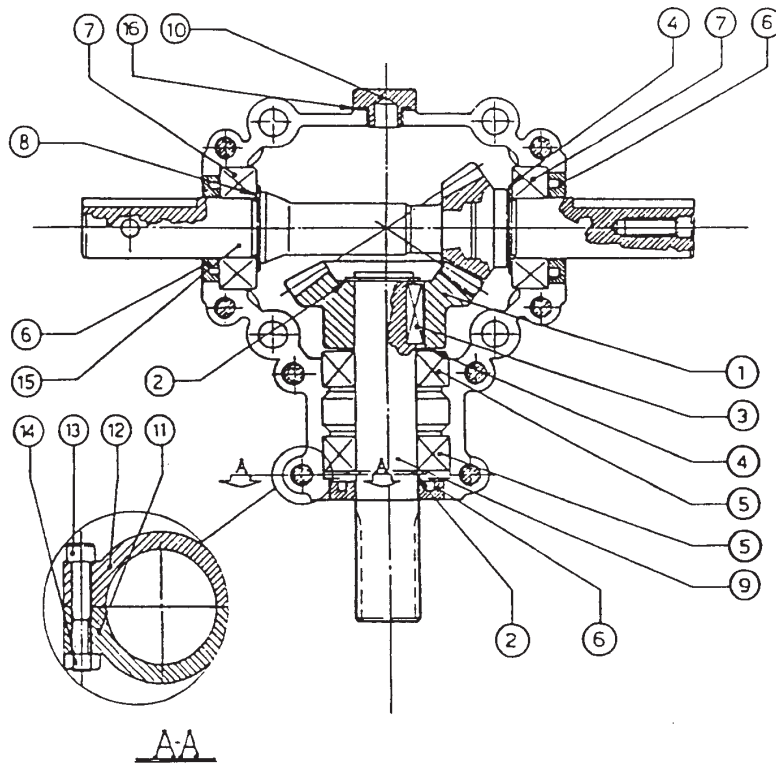

REF.	PART #	DESCRIPTION	QTY
1	6547	Gear Z24	1
2	6548	Outside circlip	2
3	6549	Parallel key 8 x 7 x 25	1
4	6562	Shim	2
5	6551	Bearing 6205	2
6	6552	Oil seal	3
7	6553	Bearing	2
8	6554	Shim	1
9	6555	Side shaft (1")	1
10	6556	Plug 3/8" GAS	1
11	6557	Casing A	1
12	6558	Casing A	1
13	6559	Bolt M8 x 45 8,8	8
14	6428	Hex. nut M8 8	8
15	6560	Pinion shaft Z16 for impeller (1" & 1")	1
16	6425	O-ring OR-3062	1

GEAR BOX # 8251 (T27D)

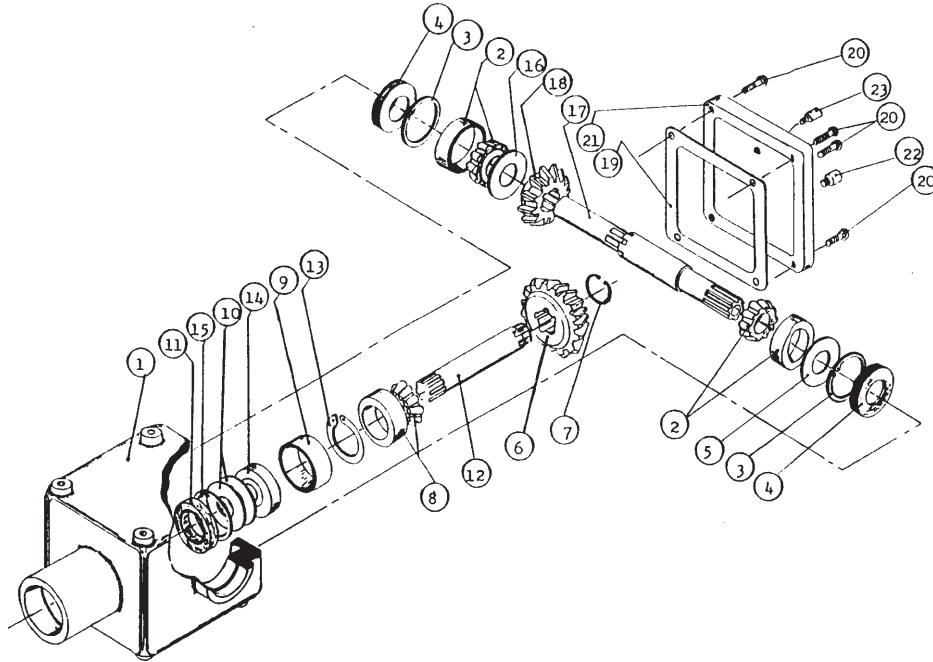

REF.	PART #	DESCRIPTION	QTY
1	8043	Casing	1
2	8044	Roller bearing no. 30208	2
3	8045	Inside circlip 80mm	2
4	8046	Oil seal 40 x 80 x 12mm	2
5	8047	Adjusting washer	1
6	8048	Gear Z18	1
7	8049	Outside circlip 40mm	1
8	8050	Roller bearing no. 30207	1
9	8051	Spacer ring	1
10	8052	Adjusting washer	2
11	8053	Oil seal 35 x 72 x 12mm	1
12	8054	Side shaft (1 ¼" - 19 splines)	1
13	8055	Outside circlip 35mm	1
14	8056	Ball bearing no. 6207	1
15	8057	Inside circlip 72mm	1
16	8058	Adjusting washer	1
17	8252	Impeller shaft (40 mm & 1 3/8" - 6 splines)	1
18	8060	Gear Z-18	1
19	8061	Gasket	1
20	8062	Bolt M10 x 14mm	4
21	8063	Cover	1
22	8064	Oil plug	1
23	8065	Oil filler plug	1

CYLINDER 25TR04

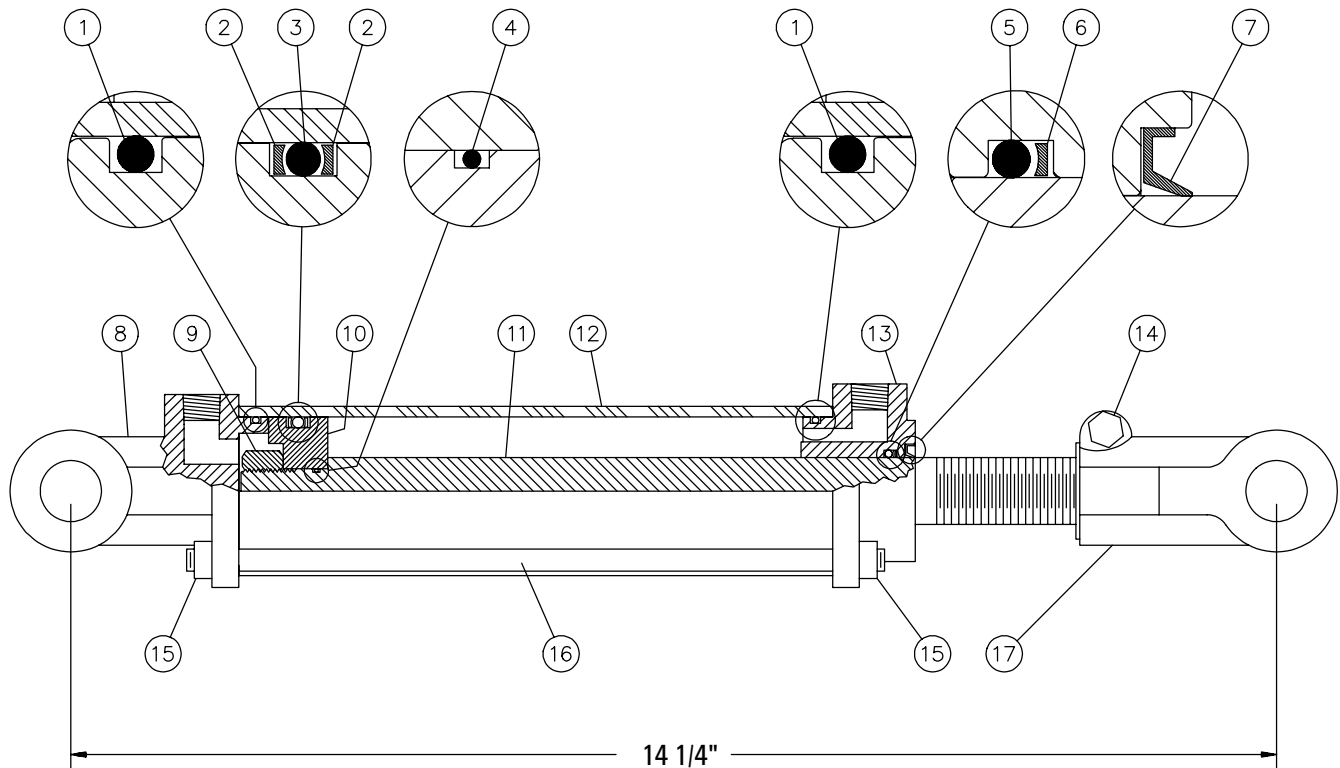

REF.	PART #	DESCRIPTION	QTY
1	See #RK25TR	O-ring 1/8" x 2 1/4" x 2 1/2"	2
2	See #RK25TR	Back-up 2 1/2" o.d. x 3/16 ø	2
3	See #RK25TR	O-ring 3/16" x 2 1/8" x 2 1/2"	1
4	See #RK25TR	O-ring 1/16" x 5/8" x 3/4"	1
5	See #RK25TR	O-ring 1/8" x 1 1/8" x 1 3/8"	1
6	See #RK25TR	Back-up 1 3/8" o.d. x 1/8" ø	1
7	See #RK25TR	Wiper 1 1/8" i.d. x 1 5/8" o.d.	1
8	492401	Yoke (for 2 1/2" tube)	1
9	338-46000	Nut 3/4" NF	1
10	4924-31	Piston 2 1/2" ø	1
11	491980-04	Piston rod 1 1/8"	1
12	491668-04	Cylinder body 2 1/2" ø	1
13	492421	Head (for 2 1/2" tube)	1
14	300-36355	Bolt 3/8" NC x 2 1/4" + nut	1
15	336-36000	Nut 3/8" NC	8
16	Std.	Threaded rod 3/8" NC x 8" lg	4
17	458599	Yoke (for 1 1/8" rod)	1
NI*	8183	Pin 1" ø + cotter pin	2
NI*	RK25TR	Repair kit for cylinder 2 1/2" (includes # 1, 2, 3, 4, 5, 6, & 7)	1

*NI = NOT ILLUSTRATED

CYLINDER 25TR08

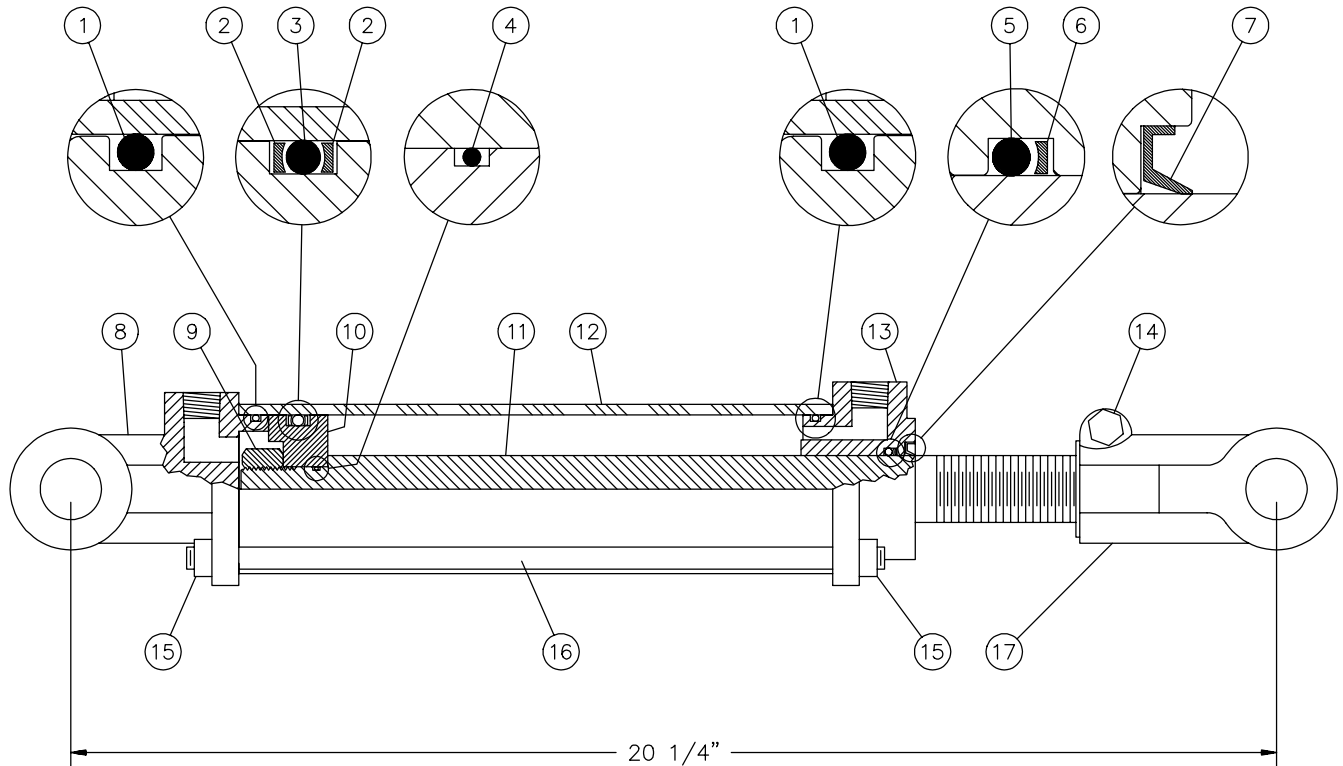







REF.	PART #	DESCRIPTION	QTY
1	See #RK25TR	O-ring 1/8" x 2 1/4" x 2 1/2"	2
2	See #RK25TR	Back-up 2 1/2" o.d. x 3/16 ø	2
3	See #RK25TR	O-ring 3/16" x 2 1/8" x 2 1/2"	1
4	See #RK25TR	O-ring 1/16" x 5/8" x 3/4"	1
5	See #RK25TR	O-ring 1/8" x 1 1/8" x 1 3/8"	1
6	See #RK25TR	Back-up 1 3/8" o.d. x 1/8" ø	1
7	See #RK25TR	Wiper 1 1/8" i.d. x 1 5/8" o.d.	1
8	492401	Yoke (for 2 1/2" tube)	1
9	338-46000	Nut 3/4" NF	1
10	4924-31	Piston 2 1/2" ø	1
11	491980	Piston rod 1 1/8"	1
12	491668	Cylinder body 2 1/2" ø	1
13	492421	Head (for 2 1/2" tube)	1
14	300-36355	Bolt 3/8" NC x 2 1/4" + nut	1
15	336-36000	Nut 3/8" NC	8
16	Std.	Threaded rod 3/8" NC x 12" lg	4
17	458599	Yoke (for 1 1/8" rod)	1
NI*	8183	Pin 1" ø + cotter pin	2
NI*	RK25TR	Repair kit for cylinder 2 1/2" (includes # 1, 2, 3, 4, 5, 6, & 7)	1





*NI = NOT ILLUSTRATED

TORQUE CHART

TORQUE SPECIFICATION TABLE

Thread UNC and UNF		Grade 2 				Grade 5   				Grade 8*   			
Bolt size		Torque				Torque				Torque			
Inches	mm	Pound feet min.	max.	Newton meters min.	max.	Pound feet min.	max.	Newton meters min.	max.	Pound feet min.	max.	Newton meters min.	max.
1/4	6.35	5	6	6.8	8.13	9	11	12.2	14.9	12	15	16.3	30.3
5/16	7.94	10	12	13.6	16.3	17	20.5	23.1	27.8	24	29	32.5	39.3
3/8	9.53	20	23	27.1	31.2	35	42	47.5	57.0	45	54	61.0	73.2
7/16	11.11	30	35	40.7	47.4	54	64	73.2	86.8	70	84	94.9	113.9
1/2	12.70	45	52	61.0	70.5	80	96	108.5	130.2	110	132	149.2	179.0
9/16	14.29	65	75	88.1	101.6	110	132	149.2	179.0	160	192	217.0	260.4
5/8	15.88	95	105	128.7	142.3	150	180	203.4	244.1	220	264	298.3	358.0
3/4	19.05	150	185	203.3	250.7	270	324	366.1	439.3	380	456	515.3	618.3
7/8	22.23	160	200	216.8	271.0	400	480	542.4	650.9	600	720	813.6	976.3
1	25.40	250	300	338.8	406.5	580	696	786.5	943.8	900	1080	1220.4	1464.5
1 1/8	25.58	-	-	-	-	800	880	1084.8	1193.3	1280	1440	1735.7	1952.6
1 1/4	31.75	-	-	-	-	1120	1240	1518.7	1681.4	1820	2000	2467.9	2712.0
1 3/8	34.93	-	-	-	-	1460	1680	1979.8	2278.1	2380	2720	3227.3	3688.3
1 1/2	38.10	-	-	-	-	1940	2200	2630.6	2983.2	3160	3560	4285.0	4827.4

* Thick nuts must be used with grade 8 bolts.

Size of screw	Thread	Pitch (mm)	Grade 4T  				Grade 7T 				Grade 8T  			
			Torque				Torque				Torque			
			Pound feet min.	max.	Newton meters min.	max.	Pound feet min.	max.	Newton meters min.	max.	Pound feet min.	max.	Newton meters min.	max.
M6	UNC	1.00	3.6	5.8	4.9	7.9	5.8	9.4	7.9	12.7	7.2	10	9.8	13.6
M8	UNC	1.25	7.2	14	9.8	19	17	22	23	29.8	20	26	27.1	35.2
M10	UNC	1.5	20	25	27.1	33.9	34	40	46.1	54.2	38	46	51.5	62.3
M12	UNC	1.75	28	34	37.9	46.1	51	59	69.1	79.9	57	66	77.2	89.4
M14	UNC	2.0	49	56	66.4	75.9	81	93	109.8	126	96	109	130.1	147.7
M16	UNC	2.0	67	77	90.8	104.3	116	130	157.2	176.2	129	145	174.8	196.5
M18	UNC	2.0	88	100	119.2	136	150	168	203.3	227.6	175	194	237.1	262.9
M20	UNC	2.5	108	130	146.3	176.2	186	205	252	277.8	213	249	288.6	337.4
M8	UNF	1.0	12	17	16.3	23	19	27	25.7	36.6	22	31	29.8	42
M10	UNF	1.25	20	29	27.1	39.3	35	47	47.4	63.7	40	52	54.2	70.5
M12	UNF	1.25	31	41	42	55.6	56	68	75.9	92.1	62	75	84	101.6
M14	UNF	1.5	52	64	70.5	86.7	90	106	122	143.6	107	124	145	168
M16	UNF	1.5	69	83	93.5	112.5	120	138	162.6	187	140	158	189.7	214.1
M18	UNF	1.5	100	117	136	158.5	177	199	239.8	269.6	202	231	273.7	313
M20	UNF	1.5	132	150	178.9	203.3	206	242	279.1	327.9	246	289	333.3	391.6

Use the above torques when special torque is not given.

NOTE: These values apply to fasteners as received from supplier, dry, or when lubricated with normal engine oil. They do not apply if extreme pressure lubricants are used.

WARRANTY

PRONOVOST warrants this product to the initial purchaser for the period of one year from the date of purchase against defects in materials and workmanship.

We will replace or repair defective parts free of charge if they are returned to our plant in St-Tite, Quebec, Canada.

Transportation charges are the responsibility of the customer. This warranty is not transferable.

Hydraulic cylinders are covered by the manufacturer of these items.

All PRONOVOST spare parts purchased are covered by a three (3) month warranty.

This warranty becomes void and nul if the equipment is modified, breaks down as the result of an accident, is not operated according to manufacturer's recommendations, damaged by negligence or if maintenance has not been carried out as specified.

Our obligation is limited to the replacement or repair of the defective part. PRONOVOST accepts no responsibility for direct or indirect consequential damages of any kind.

Ce manuel est aussi disponible en français.
Veuillez téléphoner.



INNOVATION - EXCELLENCE

LES MACHINERIES PRONOVOST INC.
260, route 159,
Saint-Tite, Quebec, Canada, G0X 3H0
Tel.: (418) 365-7551, Fax: (418) 365-7954
E-mail: info@pronovost.qc.ca
Website: www.pronovost.qc.ca