

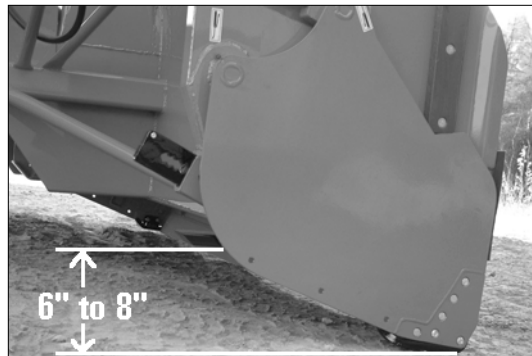

OPERATOR'S / PARTS MANUAL

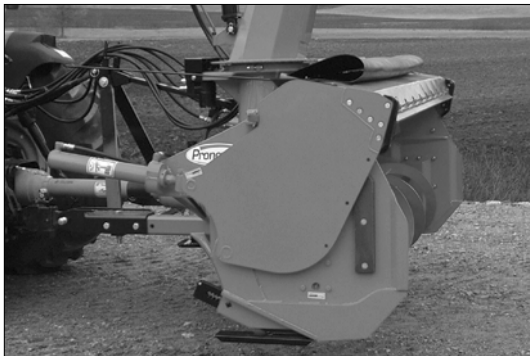

Snowblowers Models

PXPL-86
PXPL-86-92

PXPL-92
PXPL-92-98

VISIT OUR WEBSITE



www.pronovost.qc.ca

Copyright © Les Machineries Pronovost Inc., 2007

All rights reserved.
Printed in Canada.

TABLE OF CONTENTS

Section	Item	Page
1	Introduction	5
2	Safety	6
	General Safety	6
	Safety in Operation	6
	Safety with Maintenance	7
	Safety in Transport	7
	Safety in Storage	7
3	Decals	8
	Safety Decals	8
	Maintenance Decals	10
4	Assembly	13
	General assembly	13
5	Start-up	14
	Basic Start-up Procedures	14
	<i>X-PRO</i> blade adjustment	15
6	Maintenance	17
7	Storage	19
8	Trouble Shooting	20
9	Specifications	22
10	Parts List	23
	Snowblowers PXPL-86, PXPL-86-92	23
	Snowblowers PXPL-92, PXPL-92-98	27
	Chute CST-7486	31
	Semi-industrial Chute PSIG-7486	33
	Snowblower options	35
	Scraper blade and skid shoes for <i>X-PRO</i> blade	37
	P.T.O. Shaft 8202, 8202-1	39
	P.T.O. Shaft 9225-EG, 9225-1, 9569	40
	P.T.O. Shaft 9475, 9475-1, 9475-2	41
	Gear Box 8251	42
	Gear Box 9307	43
	Speed reducer 8348	44
	Speed reducer 9575	45
	Cylinder 25TR08	46
	Cylinder 25J11.5	47
	Cylinder 25J15.5	48
	Hydraulic Motor MLH-250 & MLH-315	49
11	Torque Chart	50
12	Warranty	51

INTRODUCTION

CONGRATULATIONS!

Thank you for choosing PRONOVOST. We are confident this equipment will meet your requirements in terms of quality, performance and reliability.

This manual was prepared to assist you in the safe operation of your new Snowblower. It contains important information which will help you achieve excellent returns with your Snowblower for years to come.

Please read this manual completely before operating your Snowblower and keep it for future reference.

Before starting the machine, you or any other person who will be operating the Snowblower must familiarize yourself with the safety recommendations and the operating instructions. Please read carefully and be sure to understand and follow all recommendations and procedures.

In this manual, the right and left sides are identified as shown on Figure 1.

If you require additional information on your Snowblower, please contact your PRONOVOST Dealer.

NOW take a moment to enter the model, serial number and the date of purchase of your Snowblower in the space provided.

When ordering parts from your Dealer, please refer to these numbers for a fast and efficient service. Use PRONOVOST parts for replacement.

The model and serial numbers are on the name plate shown on Fig. 1.

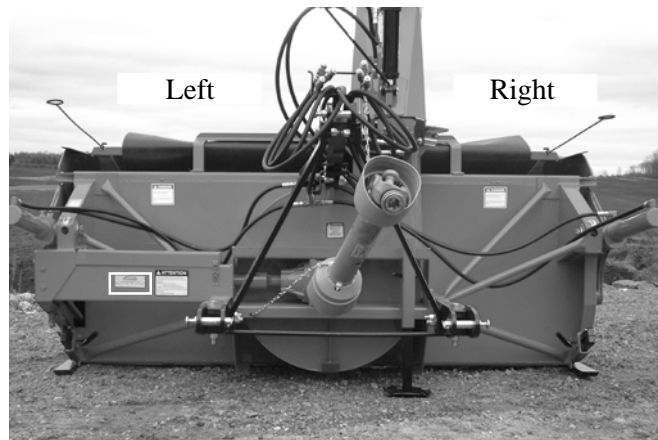

Figure 1

MODEL: _____ ✍

SERIAL NO: _____ ✍

DATE OF PURCHASE: _____ ✍

SAFETY

GENERAL SAFETY

2

WHEN YOU SEE THIS SYMBOL



ATTENTION!

**BE ALERT
YOUR SAFETY IS INVOLVED**

This symbol «**SAFETY ALERT**» is used in this manual and on the safety decals on the Snowblower. It warns you of the possibility of danger. Carefully read, understand and follow all safety recommendations before operating the Snowblower.

- 1) Careful operation is the best assurance against accidents. Carefully read this manual and follow all recommendations before operating your Snowblower. It is the owner's responsibility to make sure that anyone who will operate the Snowblower will read this manual before operating the equipment.
- 2) Familiarize yourself with all controls and always be ready to stop the Snowblower quickly in case of emergency.
- 3) Never let a child operate the Snowblower.
- 4) Do not modify the Snowblower. Any non authorized modification may affect the efficiency and/or safety of the equipment and will automatically void the warranty.
- 5) Never operate the Snowblower with defective parts or if damaged in any way. Have it repaired before operating.
- 6) Make sure all fasteners are in place and properly secured or tightened. Refer to torque chart on page 50.
- 7) Avoid wearing loose fitting clothing when working with the Snowblower. These could get entangled in moving parts of the equipment and cause accidents.

- 8) Prolonged exposure to noise may hamper hearing. Protect yourself by wearing adequate protection devices.
- 9) Hydraulic fluids under pressure can damage your skin. Do not use your hands to locate a leak.
- 10) Before the beginning of the snow season, inspect all areas where the Snowblower will be used and remove any object which may cause an accident and/or damage the equipment.
- 11) Never operate your Snowblower in poor visibility or without proper lighting conditions.

SAFETY IN OPERATION

- 1) Be sure there are no obstructions around the equipment and that no one stands near the equipment when in operation.
- 2) Do not operate an engine in a confined or non ventilated area.
- 3) Do not perform any adjustments, cleaning, maintenance or repairs with the engine running. The engine must be stopped and the P.T.O. disengaged. Preferably remove the key from the ignition.
- 4) Wear adequate clothing when working in cold or windy conditions.
- 5) Adjust skid shoes for proper ground clearance of scraper blade, especially in rough terrain or soft ground conditions.
- 6) Before operating, make sure the P.T.O. is properly installed and secured.
- 7) Before starting-up the Snowblower, make sure the auger and drum areas are free of ice.
- 8) Put P.T.O. control in neutral position before starting engine.
- 9) Keep hands, feet and clothing away from moving parts of the Snowblower. Stay away from the discharge chute.

SAFETY (cont'd)

- 10) Before unplugging the chute, always disengage the P.T.O., stop the engine and relieve all hydraulic pressures.
- 11) Do not operate in excessive inclined conditions. Be careful when turning in slopes.
- 12) Never operate your Snowblower with missing guards or without protective devices in place.
- 13) Do not operate your Snowblower near buildings, windows or other vehicles without prior and proper adjustment of the chute deflector.
- 14) Never aim discharge chute towards people or animals. This may cause serious injuries.
- 15) Always reduce operating speed in slippery conditions.
- 16) Be careful when backing-up, make sure you have good visibility.
- 17) Always be on the lookout for objects which may enter the Snowblower.
- 18) If undue vibrations are felt, disengage the P.T.O., stop the motor and look for the cause of the vibration. Vibration is usually the indication of a problem.
- 19) When you activate the X-PRO BLADE make sure nobody is behind the snowblower, because this person could be hit in the face by the proximity indicator (Fig. 12 page 10).
- 20) At the end of the operation, disengage the P.T.O., lower the Snowblower, put transmission in neutral, apply parking brake, stop engine and remove the key from the ignition.
- 2) Stop engine and relieve all hydraulic pressures before doing inspection, maintenance or repairs.
- 3) Never perform any work under the Snowblower while it is supported only by the tractor's hydraulic system. It must be completely supported by wooden blocks or other safe means.

SAFETY IN TRANSPORT

- 1) On public roads, use proper safety lights and check local regulations.
- 2) Be alert while driving on the road. Never carry passengers.
- 3) Always disengage P.T.O. while moving from one area of work to another.
- 4) It is recommended to use both brake pedals simultaneously for better control.
- 5) The recommended road speed should be such as to maintain full control over steering and braking.
- 6) Be careful while backing up, make sure you have good visibility.

SAFETY IN STORAGE

- 1) Provide adequate supports to prevent any accidental overturning of the Snowblower.
- 2) Do not let children play in the area where the snowblower is stored.
- 3) Lower X-PRO blade on the ground.

SAFETY WITH MAINTENANCE

- 1) Perform the Snowblower maintenance according to recommendations contained in this manual.

2

DECALS

SAFETY DECALS

The safety decals are affixed wherever special safety precautions are indicated. Locate them on the machine and read them carefully. If a decal is damaged, lost or illegible, install a new one. The following photos indicate where each one must be installed.

3

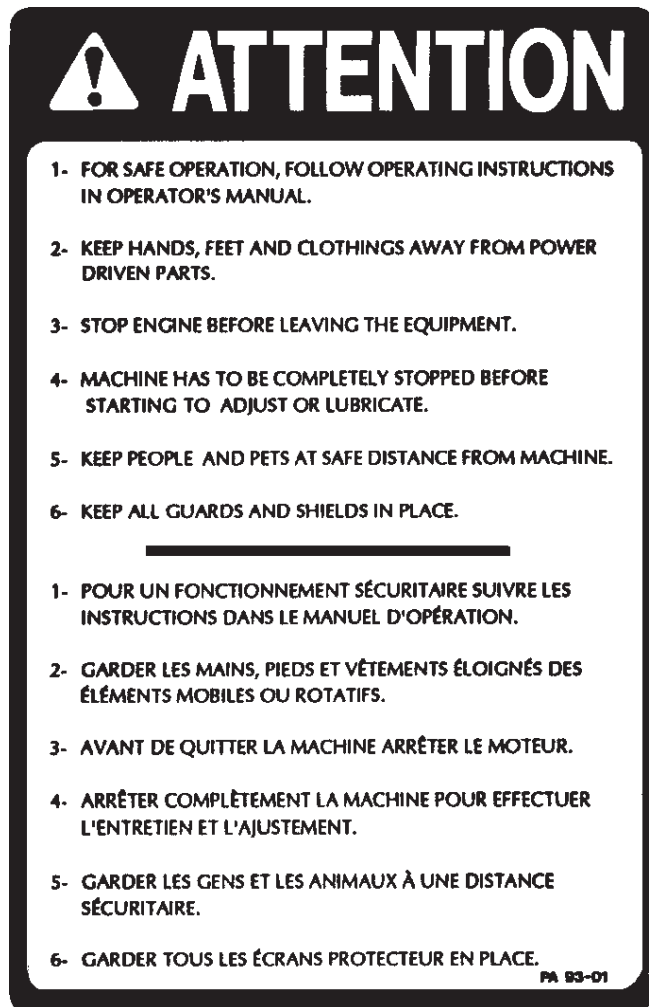

Figure 2
Decal A

Part no.: A102

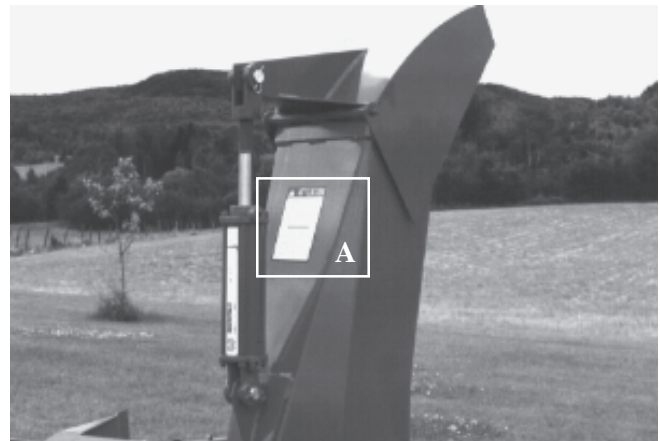

Figure 3

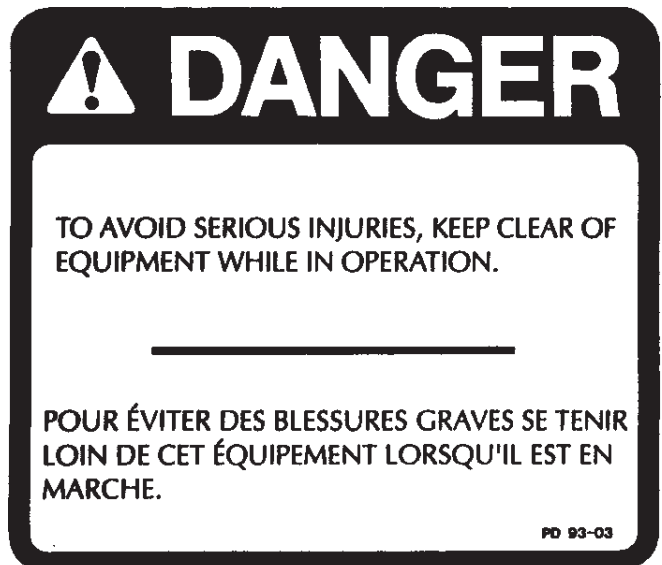

Figure 4
Decal B

Part no.: A101

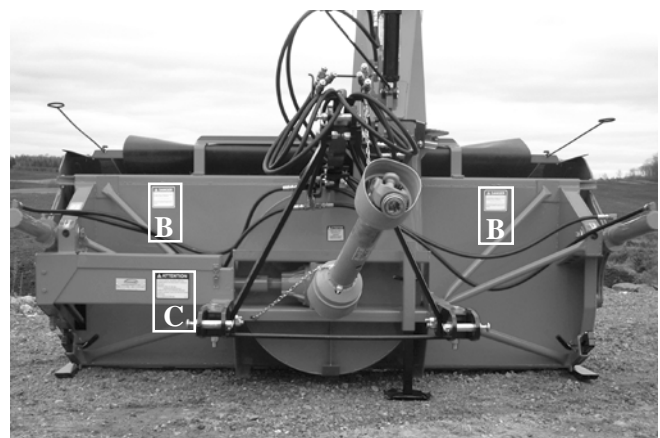

Figure 5

DECALS (cont'd)

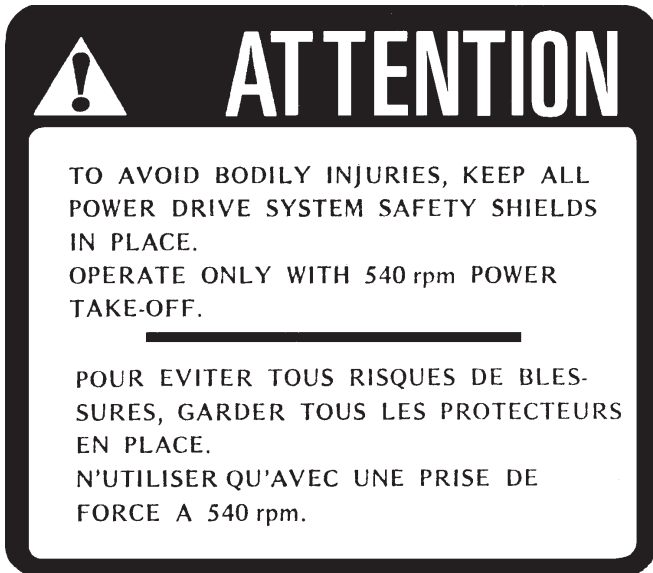

Figure 6
Decal C Part no.: A107



Figure 7
Decal D Part no.: A103



Figure 8

Decal E in Fig. 9 is located directly on the P.T.O. shaft. It is not visible when the safety shield is in place. It must never be visible when you operate the equipment.



Figure 9
Decal E Part no.: A108

3

DECALS (cont'd)

3

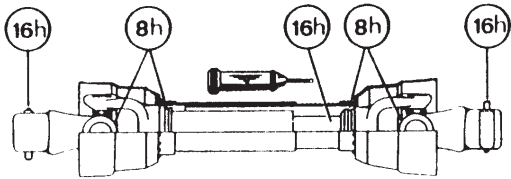

Figure 10
Decal F

Part no.: A 109

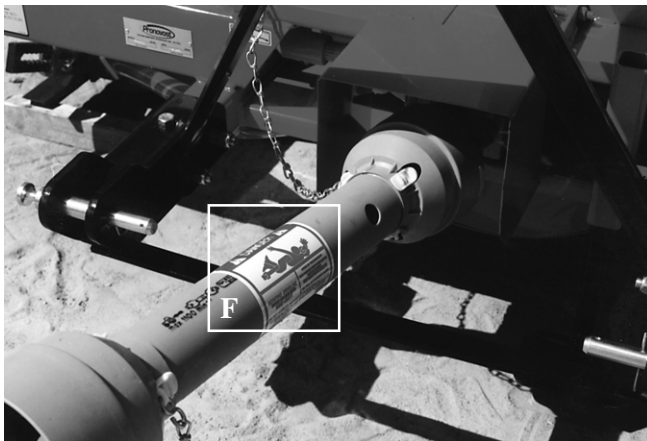

Figure 11



Figure 12

Pièce no.: 190-02651



Figure 13

MAINTENANCE DECALS

The maintenance decals indicate the points requiring lubrication. Refer to maintenance section for more details.

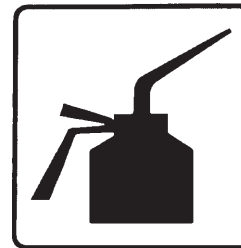

Figure 14

Pièce no.: A 105

DECALS (cont'd)



Figure 15

Pièce no.: A 106



Figure 16
Autocollant G

Pièce no.: A104

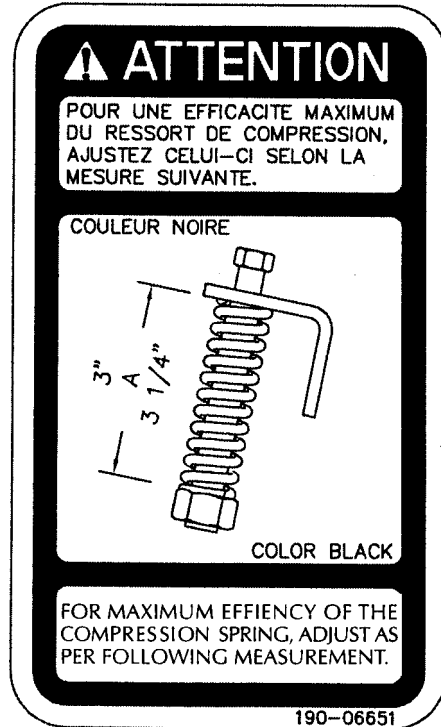

Figure 18
Autocollant H

Pièce no.: 190-06651

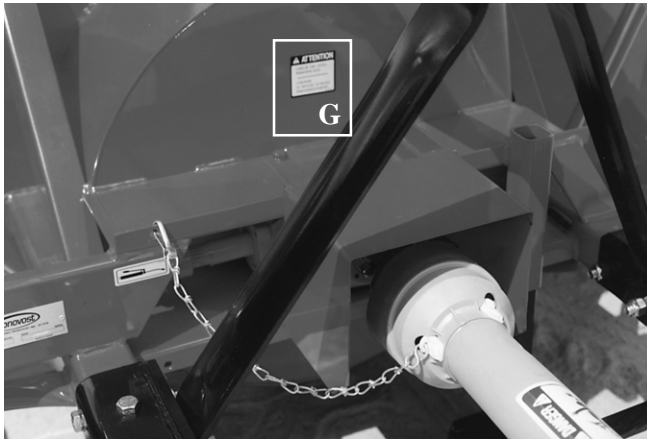

Figure 17

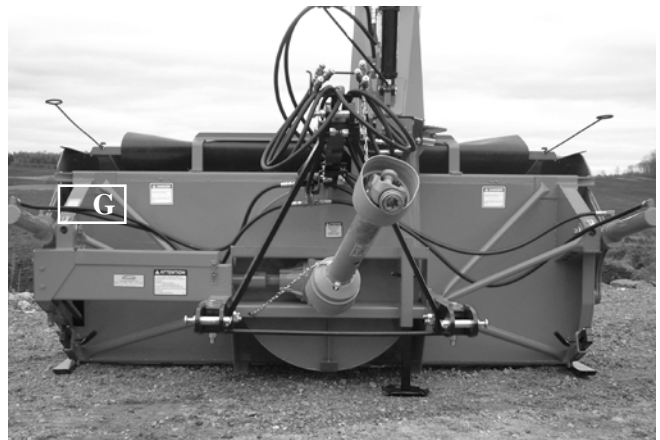

Figure 19

DECALS (cont'd)

3

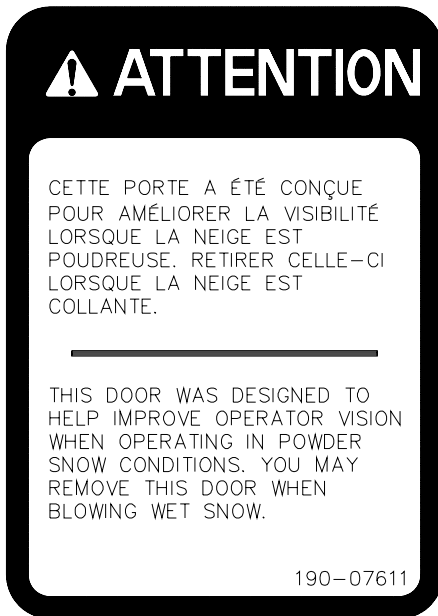

Figure 20
Decal J

Part no.: 190-07611

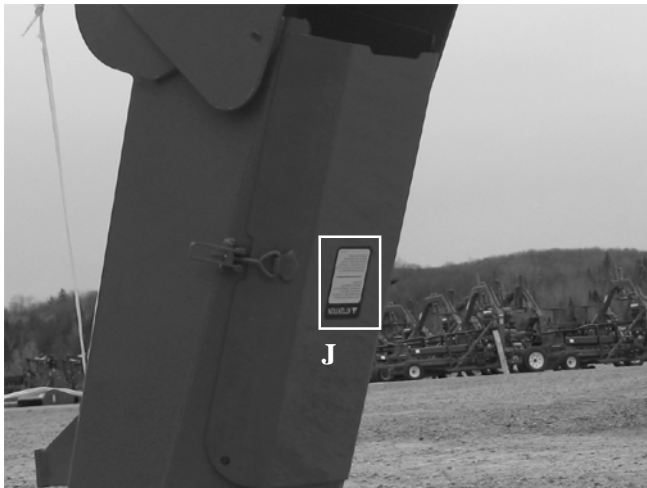

Figure 21

ASSEMBLY



Figure 22



Figure 23

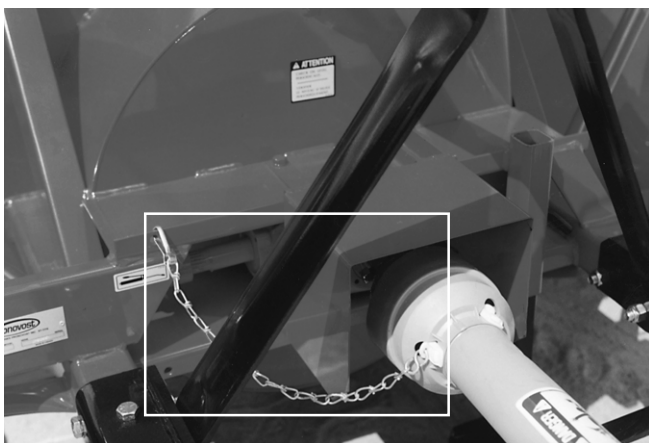

Figure 24

ASSEMBLY

- 1) The Snowblower is shipped partly assembled.
- 2) Install 3-point system according to the model of your Snowblower. (See section 10 for parts numbers). Use the holes most convenient to the type of tractor used (Fig. 22).
- 3) Install P.T.O. shaft with the shear pin end onto the Snowblower gear box (Fig. 23). Then attach safety shield support chain as shown (Fig. 24). **WARNING:** The telescoping tubes of the drive shaft must never be allowed to bottom out while maintaining a minimum overlap of 6 inches.
- 4) If you install a hydraulic cylinder on the chute deflector, use model 25TR08 cylinder.
- 5) When installing chute, grease the groove of the UHMW slide in order to prevent the corrosion of the rim of the chute.
- 6) Install the chute rotation mechanism.

4

STARTING-UP

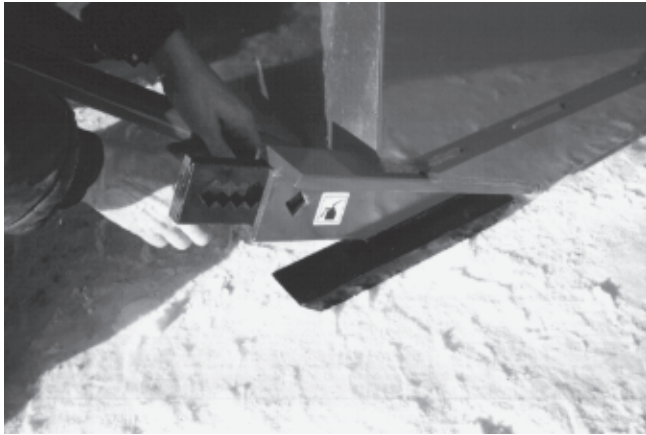

Figure 25

5

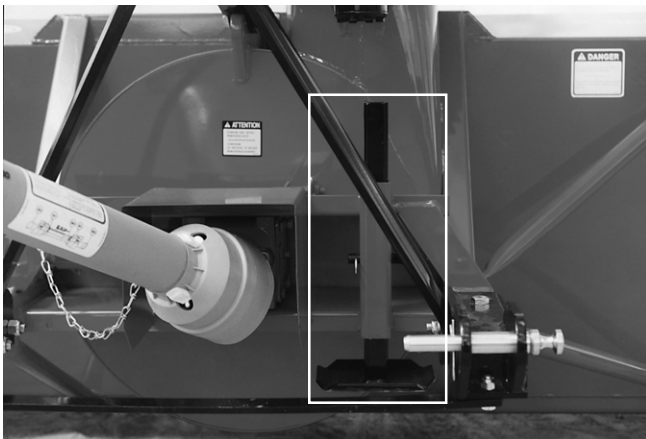

Figure 26



Figure 27

START-UP PROCEDURES

- 1) Check oil level in gearbox. Use S.A.E. W90 gear box oil.
- 2) Lubricate all points with a good quality multipurpose grease.
- 3) Check chain take-up adjustment. The spring maintaining the tension must be compressed to a length between 3" and 3 1/4".
- 4) Verify for adequate tightness of all fastening devices. Refer to torque chart on page 50.
- 5) Adjust skid shoes according to ground conditions (Fig. 25).
- 6) Following the installation of the Snowblower on the tractor, **do not forget** to lift the storage support (Fig. 26).
- 7) Make sure of a 540 RPM input to your snowblower.
- 8) Check impeller adjustment. The tip of the blades should be approximately 1/8" to 3/16" from the discharge wall of the drum. If necessary, adjust with the take-up screws provided (Fig. 27).
- 9) In order to avoid damaging your snowblower, adjust the speed of descent of your 3 point hitch to prevent striking the ground too hard.
- 10) Adjust the hydraulic flow in order to have a good control of the rotation speed of the chute.

STARTING-UP

The PXPL snowblower has been developed to fit three point hitch mount farm tractors. The lifting angle of the three point hitch varies from one model tractor to the other. Therefore in order to prevent premature wear of the skid shoes and to avoid the sides of the x-pro blade from scratching paved surfaces, **it is essential that the X-PRO blade be adjusted in the proper position before putting it into service.**

X-PRO BLADE ADJUSTMENT

- 1) Adjust the superior attachment of your tractor's 3 point hitch (if it is adjustable) to obtain a movement as shown on fig 30-H and 30-I. It provides a better scraping on various slopes.
- 2) Adjust the cylinders (fig. 28-D) to obtain a height (fig. 28-A) of approximately 6" for models PXPL-86 and PXPL-86-92 and of 8" for models PXPL-92 and PXPL-92-98. Begin the adjustment by loosening the bolt on the cylinder yoke (fig. 28-J). Take a 7/8" key and then make the number of turns necessary (fig 28-B) to obtain required dimensions (fig. 28-A).
Check that the short skid shoe (of the TIVAR or the steel shoe for the other models) is parallel to the ground or slightly raised towards the tractor (fig. 28-F).

- 3) Lift the snowblower with the 3 point hitch and lower the X-PRO blade to the maximum extension (blade cylinders (Fig. 28-D) must be extended to the maximum). Then, lower the snowblower until it is supported entirely by the X-PRO blade.
- 4) Lift the **snowblower** a couple inches and verify if the **blade** is parallel to the ground (Fig. 29-G). Rectify if needed by using the two threaded cylinders adjustments (Fig. 28-B). **WARNING:** You must make sure the **snowblower** unit is parallel to the ground. If this is not the case, check the 3 point hitch on the tractor or the level of the ground.
- 5) Lift up the snowblower and lift the X-PRO blade the highest possible. The sides (Fig. 28-E) must rest on stoppers (Fig. 28-C). A relief valve has been installed to protect the mechanism when the blade rests on the stoppers. For an optimal adjustment, tighten the valve adjustment screw to the maximum and then unscrew a half-turn.

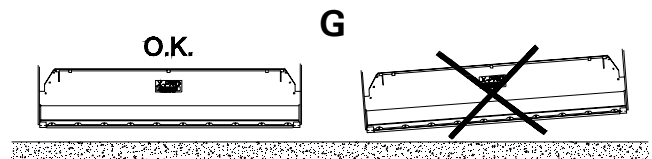

Fig. 29

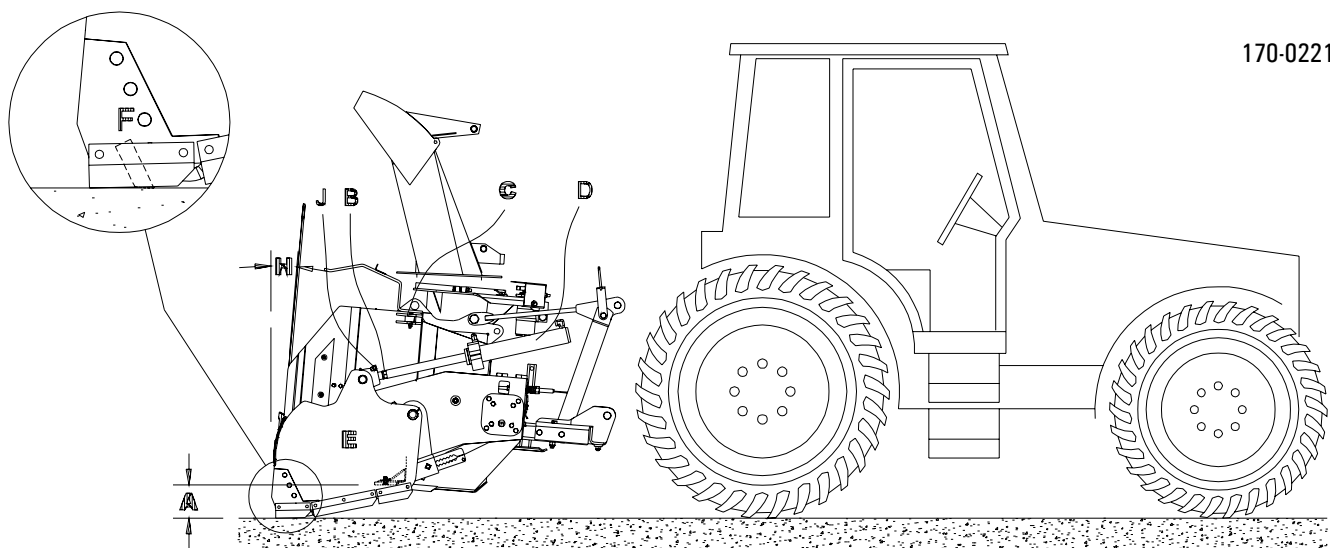
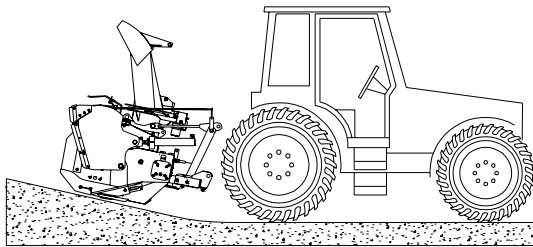

Fig. 28

170-02212

STARTING-UP (cont'd)

O.K.



H

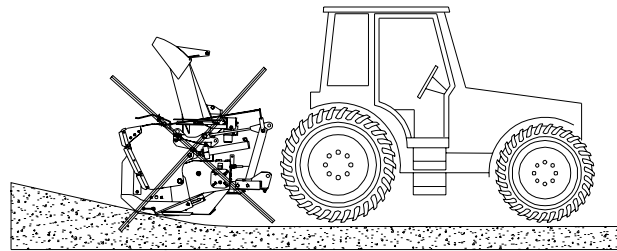

O.K.

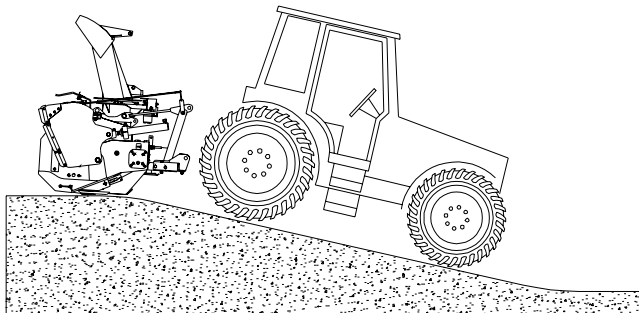

I

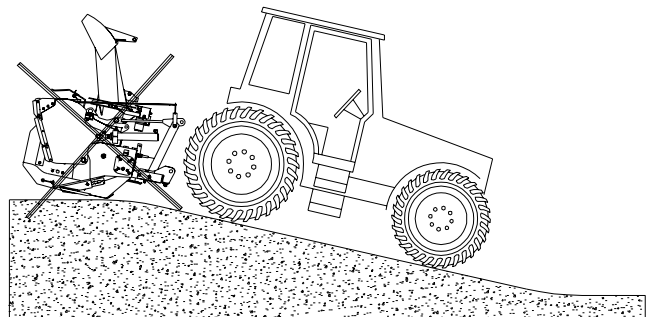

5

Fig. 30

MAINTENANCE

- 1) Wipe off all grease fittings with a clean cloth before adding grease in order to avoid injecting dirt and sand.
- 2) Repair or replace damaged grease fittings.
- 3) Lubricate all grease fittings every 8 hours of operation.
- 4) Oil drive chain every 8 hours of operation.
- 5) Lubricate P.T.O. shaft as indicated below:

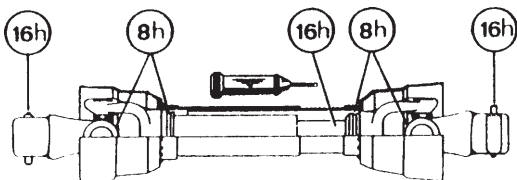

Pull out the P.T.O. and lubricate between the two tubes with low temperature grease. Drive line tubes must slide easily even in cold weather. Clean off old hardened grease and apply fresh grease as needed.

- 6) Check oil level in gear box once a month. Adjust to required oil level as per drawing in Parts List section. Use SAE 80W90 oil.
- 7) Check oil level in auger drive chain box once a month. Fill to level plug. Use SAE 80W90 oil.
- 8) Check tension of drive chain every 24 hours of operation and adjust if necessary.
- 9) Check for tightness of bearing collars every 48 hours of operation.
- 10) Change gearbox oil once a year. Adjust to required oil level as per drawing in Parts List section. Use SAE 80W90 oil.

- 11) Check all nuts and bolts once a year. If necessary use torque chart on page 50.
- 12) Standard scraper blades are reversible. Reverse when one edge is worn out.
- 13) For the auger drive shaft, always use a grade 5 shear bolt.
- 14) For the PTO shaft, always use a grade 10.9 shear bolt at 540 RPM or a grade 8.8 shear bolt at 1000 RPM.
- 15) UHMW slides do not require lubrication except at the end of the season in order to prevent corrosion of steel components that are in contact with the UHMW material.

If your snowblower is equipped with the optional speed reducer

- 16) After 10 working hours, the chain's adjustment (if applicable) must be checked and every 100 working hours. Please refer to section: Maintenance on Speed Reducer.
- 17) Check oil level in speed reducer once a month. Adjust to required oil level as per drawing in Parts List section. Use SAE 80W90 oil.
- 18) Drain the oil of the speed reducer once a year. Adjust to required oil level as per drawing in Parts List section. Use SAE 80W90 oil.

6

MAINTENANCE ON SPEED REDUCER

It is extremely important that the chain inside the chain box is **tightened**. A loose chain will add shocks to the entire box (chain, sprockets, bearings and spline couplings to gearbox).

Instructions for speed reducer (with chains) maintenance

This chain box has double functions.

- 1) Reduce angles at both ends of PTO in working position by increasing the input shaft height of 8".
- 2) Increase PTO capacity by increasing speed from 540 RPM to 1000 RPM.

ADJUSTMENT OF THE CHAIN'S TENSION

After 10 working hours, the chain's adjustment must be checked. In order to do so, verify the backlash between the input and the output shaft by turning the input shaft in both directions while the output shaft remains still. If there is a play of 10° or more, the chain must then be readjusted as follows:

- 1) Remove PTO from the chain box.
- 2) Unscrew the 12 bolts 5/16" dia. (item #22) from covers (items #7 and #15) around the input shaft on both sides of the chain box (6 bolts on each side).

NOTE: Input shaft covers are eccentric with outside of covers. Therefore by turning input shaft cover, center to center distance of shafts will be changed and thus, this will adjust the chain's tension.

- 3) With a hammer and a screw-driver or a chisel, gently turn both covers in the same direction until the next hole of the cover is in line with the threaded hole of the chain box.

IMPORTANT: Make sure that the covers are turned in the same direction and by the same number of holes.

Otherwise, both shafts will not be parallel and serious damages might arise.

- 4) Verify the backlash between both shafts, as described above. If the difference is too high, repeat the operation explained in point 3. If the backlash is correct, reinstall the bolts and the PTO.
- 5) Verify the backlash every 100 working hours.

MAINTENANCE ON SPEED REDUCER

- 1) Check oil level in speed reducer once a month. Adjust to required oil level as per drawing in Parts List section. Use SAE 80W90 oil.
- 2) Drain the oil of the speed reducer once a year. Adjust to required oil level as per drawing in Parts List section. Use SAE 80W90 oil.

6

STORAGE

- 1) Store the Snowblower in a cool, dry place.
- 2) Support the Snowblower with wooden blocks.
- 3) Keep all piston rods in the retracted position. This will assure better protection against the elements.
- 4) Clean your Snowblower.
- 5) Thoroughly inspect all parts of the Snowblower. Replace or repair worn or defective parts.
- 6) Touch-up or repaint if necessary.
- 7) Lubricate all points before storage.

TROUBLESHOOTING

P.T.O. SHAFT

PROBLEM	POSSIBLE CAUSE	CORRECTION
- Premature wear of U-joints and/or bluish color of cross journals.	- Insufficient lubrication. - Excessive working angle.	- Follow lubrication recommendations. - Replace defective U-joints. - Make sure the snowblower inlet face is perpendicular to the ground and if possible readjust 3-point hitch in order to position the snowblower further away from tractor.
- Gripping or premature wear of telescoping members.	- Too much sliding under load. - Tube overlap too-short: minimum recommended is 6". - Insufficient lubrication. - Contaminants (sand, etc.).	- Avoid raising snowblower while in operation. - Readjust 3-point hitch in order to position the snowblower closer to the tractor. - Follow lubrication recommendations. - Replace defective telescopic members.
- Damaged or jammed locking pin or bolt.	- Pin or orifice contaminated by sand, ice, etc. - Telescoping members too long, exerting pressure on locking device.	- Clean and grease. - Readjust 3-point hitch in order to position the snowblower further away from tractor.
- Premature wear of guard tube bearing ring.	- Lack of lubrication. - Wrong installation of guard chain. - Part of the guard in contact with the equipment.	- Follow lubrication instructions. - Adjust chain to prevent interference between guard & equipment. - Replace worn or damaged bearing rings.
- Cut or deformed safety guard tubes.	- Tubes in contact with the equipment.	- Eliminate any interference between tubes and equipment or tractor. - Replace damaged tubes.

TROUBLESHOOTING (cont'd)

SNOWBLOWER

PROBLEM	POSSIBLE CAUSE	CORRECTION
- The snow is not being thrown as far as usual.	- Tractor RPM too low. - Gap too wide between impeller blade tip and drum outlet wall. - Insufficient tractor HP.	- Raise P.T.O. speed to a minimum of 540 RPM. - Adjust impeller blades closer to drum outlet (1/8" to 3/16"). - Reduce travel speed.
- Frequent plugging of discharge chute.	- Tractor RPM too low. - Tractor RPM reduced too early with snow still in the snowblower. - Slippage of PTO clutch mechanism. - Wet snow condition.	- Raise P.T.O. speed to a minimum of 540 RPM. - Make sure the snowblower is completely empty before reducing RPM, especially on tractors with foot controlled RPM. - Repair clutch. - Reduce travel speed.
- The impeller will not turn.	- Shear bolt broken on drive shaft.	- Replace shear bolt.
- The auger will not turn.	- Shear bolt broken on drive shaft. - Shear bolt broken on auger drive shaft. - Broken drive chain.	- Replace shear bolt. - Replace shear bolt. - Fix or replace chain.
- The chute will not turn.	- Ice accumulation. - Wrong hydraulic connections.	- Remove ice. - Check hydraulic connections.

SPECIFICATIONS

Snowblower model		PXPL-86	PXPL-86-92	PXPL-92	PXPL-92-98
Horse power recommended min. - max.		50 to 75 HP	50 to 75 HP	75 to 125 HP	75 to 125 HP
Working width - snowblower		86" (218.44)	92" (233.68)	92" (233.68)	98" (248.92)
Working width - X-PRO blade		87 ⁵ / ₈ " (222.57)	93 ⁵ / ₈ " (237.82)	93 ³ / ₄ " (237.82)	99 ³ / ₄ " (253.37)
Cutting height - snowblower	po. (cm)	30" (76.20)	30" (76.20)	33 3/4" (85.73)	33 3/4" (85.73)
Cutting height - X-PRO blade	po. (cm)	6" (15.24)	6" (15.24)	8" (20.32)	8" (20.32)
Height - Chute base	po. (cm)	36 ⁵ / ₈ " (93.03)	36 ⁵ / ₈ " (93.03)	42 ³ / ₈ " (107.63)	42 ³ / ₈ " (107.63)
Impeller diameter	po. (cm)	28" (71.12)	28" (71.12)	32" (81.28)	32" (81.28)
Depth of drum	po. (cm)	12" (30.48)	12" (30.48)	12" (30.48)	12" (30.48)
Impeller blades		4	4	5	5
Size of impeller shaft	po. (cm)	1 ⁹ / ₁₆ " (3.97)	1 ⁹ / ₁₆ " (3.97)	2" (5.08)	2" (5.08)
Height - Impeller center	po. (cm)	16" (40.64)	16" (40.64)	18 ¹ / ₄ " (46.36)	18 ¹ / ₄ " (46.36)
Impeller RPM		540	540	540	540
Number of augers		1	1	1	1
Auger diameter	po. (cm)	16 ¹ / ₂ " (41.91)	16 ¹ / ₂ " (41.91)	19 ¹ / ₂ " (49.53)	19 ¹ / ₂ " (49.53)
Drive chain - auger		80	80	80	80
Oil bath sealed gear box		Std.	Std.	Std.	Std.
Chute rotation mechanism for motor		Std.	Std.	Std.	Std.
Number of shear bolts		2	2	2	2
Hitch category		2	2	2	2
Balanced impeller		Std.	Std.	Std.	Std.
Balanced auger		Std.	Std.	Std.	Std.
1000 to 540 RPM reducer		Opt.	Opt.	Opt.	Opt.
Scraper blade	Std. steel - reversible	Std.	Std.	Std.	Std.
	Carbon steel 1/2" x 4"	Opt.	Opt.	Opt.	Opt.
	Carbon steel 1/2" x 6"	Opt.	Opt.	Opt.	Opt.
	Tivar	Opt.	Opt.	Opt.	Opt.
	Stainless steel 1/2" x 4"	Opt.	Opt.	Opt.	Opt.
Adjustables skid shoes	Standard steel	Std.	Std.	Std.	Std.
	Carbon steel	Opt.	Opt.	Opt.	Opt.
	Stainless steel	Opt.	Opt.	Opt.	Opt.
Scraper blade & skid shoes on X-PRO blade	Standard steel	Std.	Std.	Std.	Std.
	Carbon steel	Opt.	Opt.	Opt.	Opt.
	Tivar	Opt.	Opt.	Opt.	Opt.
	Stainless steel	Opt.	Opt.	Opt.	Opt.
Full flight main auger (industrial)		Opt.	Opt.	Opt.	Opt.
Chute	regular	Opt.	Opt.	Opt.	Opt.
	semi-industrial	Opt.	Opt.	Opt.	Opt.
Deflector	manuall	Opt.	Opt.	Opt.	Opt.
	hydraulic	Opt.	Opt.	Opt.	Opt.
Bearing / ductile iron casing		Std.	Std.	Std.	Std.
Lateral blades		Opt.	Opt.	Opt.	Opt.
P.T.O. shaft	(standard)	No. 6	No. 6	No. 8	No. 8
P.T.O. shaft	(optional)	No. 8	No. 8	No. 9	No. 9
Weight ¹	lbs (kg)	1822 (826)	1860 (844)	2059 (934)	2099 (952)

¹Including PSIG-7486 chute, P.T.O. and hydraulic motor.

Design and specifications subject to change without notice.

SNOWBLOWERS PXPL-86 PXPL-86-92

170-03643R2

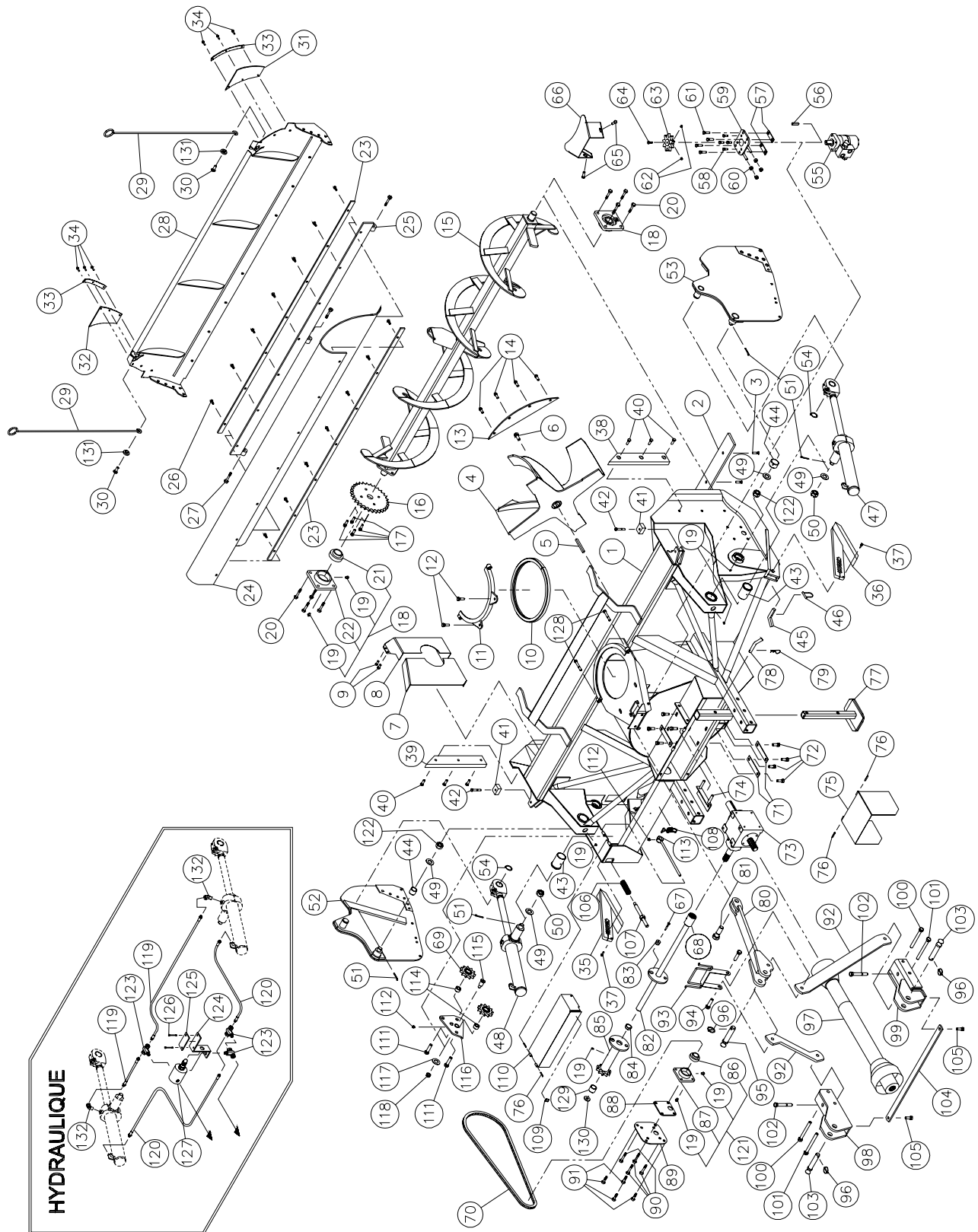

SNOWBLOWERS PXPL-86 PXPL-86-92 (cont'd)

REF.	PART #	DESCRIPTION	QTY	
			PXP-86	PXP-8692
1	120-05032	Frame PXPL-86	1	-
1	120-04612	Frame PXPL-8692	-	1
2	140-00912	Scraper blade reversible 1/2" x 4" x 79 3/4" lg	1	-
2	140-09492	Scraper blade reversible 1/2" x 4" x 85 3/4" lg	-	1
3	319-38310	Plow bolt 7/16" NC x 1 1/2" lg + nut & lockwasher	8	9
4	110-01882	Impeller 28" dia. 4 blades	1	1
5	8030	Key 3/8" x 3/8" x 3 1/2"	1	1
6	300-44310	Bolt 5/8" NC x 1 1/2" lg (ass. with lock-tite 242) + lock washer	1	1
7	130-35251	Inside guard (welded)	1	1
8	130-35262	Inside guard (bolted)	1	1
9	300-36250	Bolt 3/8" NC x 1" lg + nylon locknut & flat washer	4	4
10	8149	U-shaped UHMW	1	1
11	110-01341	Retaining bracket	1	1
12	300-40310	Bolt 1/2" NC x 1 1/2" lg + nylon locknut & flat washer	2	2
13	130-36081	Deflector	1	1
14	301-38280	Bolt 7/16" NC x 1 1/4" lg + nylon locknut	4	4
15	110-26031	Auger PXPL-86	1	-
15	110-23151	Auger PXPL-8692	-	1
16	9281	Sprocket 80A30 T 1 1/2" dia.	1	1
17	300-38310	Bolt 7/16" NC x 1 1/2" lg + two way locknut	4	4
18	UCFD208-24	Bearing 1 1/2" + flange & grease fitting (straight)	2	2
19	Std.	Grease fitting 1/4"-28 straight	10	10
20	300-40310	Bolt 1/2" NC x 1 1/2" lg + nylon locknut & flat washer 7/16"	8	8
21	UC208-24	Bearing 1 1/2"	2	2
22	FD208	Flange for 4 grease fitting	2	2
23	140-07301	Back plate for shroud hinge and stationary hold down 1/4" x 1" x 65" (PXPL-86)	2	-
23	140-07291	Back plate for shroud hinge and stationary hold down 1/4" x 1" x 71" (PXPL-8692)....	-	2
24	190-07161	Shroud 27" x 65" (PXPL-86)	1	-
24	190-06381	Shroud 30" x 71" (PXPL-8692)	-	1
25	110-22422	Shroud hinge 65" (PXPL-86)	1	-
25	110-09532	Shroud hinge 71" (PXPL-8692)	-	1
26	300-34280	Bolt 5/16" NC x 1 1/4" lg + nylon locknut	14	16
27	300-38400	Bolt 7/16" NC x 3" lg + nylon locknut	3	3
28	110-25902	Plow PXPL-86	1	-
28	110-23162	Plow PXPL-8692	-	1
29	190-02193	Proximity indicator	2	2
30	300-40310	Bolt 1/2" NC x 1 1/2" lg + nylon locknut	2	2
31	190-09541	Right flap	1	1
32	190-09542	Left flap	1	1
33	140-20861	Flap hold down 1/8" x 1" x 10" lg	2	2
34	300-32250	Bolt 1/4" NC x 1" lg + nylon locknut & flat washer	6	6
35	110-03151	Skid shoe (left)	1	1
36	110-05491	Skid shoe (left)	1	1
37	300-32280	Bolt 1/4" x 1 1/4" lg + nylon locknut	2	2
38	190-06331	Right hand guide	1	1
39	190-06332	Left hand guide	1	1
40	319-38325	Plow bolt 7/16" NC x 1 3/4" lg + nylon locknut	6	6
41	190-07031	Stopper shock absorber	2	2
42	302-36370	Bolt 3/8" NC x 2 1/2" lg + nylon locknut	2	2
43	160-12041	Bushing 2" i.d. x 2 1/2" o.d. x 3 3/8" lg	2	2

SNOWBLOWERS PXPL-86 PXP-86-92 (cont'd)

REF.	PART #	DESCRIPTION	QTY	
			PXPL-86	PXP-8692
44	160-12001	Bushing 1 3/4" i.d. x 2" o.d. x 1 3/16" lg	2	2
45	140-01861	Skid shoes lock	2	2
46	8112	Lock pin 1/4"	2	2
47	25J11.5D	Hydraulic cylinder (right side) 2 1/2" x 11 1/2" stroke (see page # 47)	1	1
48	25J11.5G	Hydraulic cylinder (left side) 2 1/2" x 11 1/2" stroke (see page # 47)	1	1
49	376-50000	Flat washer 1" i.d. x 2 1/2" o.d.	2	2
50	358-50235	Castle nut 1"-14 x 7/8" thick	2	2
51	Std.	Cutter pin 5/32" x 2" lg	4	4
52	110-23243	Pivoting side (left)	1	1
53	110-23244	Pivoting side (right)	1	1
54	Std.	External retaining ring 1 1/2"	2	2
55	MLH-315	«Orbit» hydraulic motor + cushion valve	opt	opt
56	8369	Key for hydraulic motor	1	1
57	140-09571	Spacer 1/8" x 1" x 3 1/4" lg for «Orbit» motor	2	2
58	300-36250	Bolt 3/8" NC x 1" lg + lock washer	4	4
59	110-20811	«Orbit» motor support	1	1
60	336-38000	Nut 7/16" NC	4	4
61	300-38310	Bolt 7/16" NC x 1 1/2" lg + nylon locknut & flat washer	4	4
62	323-36160	Hexagonal socket set screw 3/8" NC x 3/8" lg	2	2
63	110-04182	Sprocket 9 tooth	1	1
64	300-32220	Bolt 1/4" NC x 3/4" lg + lock washer	1	1
65	300-38280	Bolt 7/16" NC x 1 1/4" lg + nylon locknut & flat washer	2	2
66	130-08162	Guard	1	1
67	300-32340	Bolt 1/4" NC x 2" lg + nylon locknut	1	1
68	6466	Splined adaptor 1 1/4"-19 splines (welded)	1	1
69	9287	Idler sprocket #80	2	2
70	190-07051	Chain #80 x 71" lg (71 links)	1	1
70	26A80	Connecting link no.80	1	1
70	59-80	Offset link no.80	1	1
71	140-10571	Back plate	3	3
72	300-40250	Bolt 1/2" NC x 1" lg + lock washer	8	8
73	8251	Gear box T27D	1	1
74	110-05311	Adjustment plate for gear box + 4 nuts 1/2" NC	1	1
75	110-12421	Hinged P.T.O. shroud	1	1
76	Std.	Roll pin 5/16" x 2" lg	4	4
77	110-23731	Storage support	1	1
78	8220	Storage support pin	1	1
79	Std.	Hitch pin clip 5/32"	1	1
80	110-23143	Upper hitch	1	1
81	300-50400	Bolt 1" NC x 3" lg + nylon locknut	1	1
82	110-25872	Auger drive shaft x 32 5/16" PXPL-86	1	-
82	110-23372	Auger drive shaft x 35 5/16" PXPL-8692	-	1
83	150-05471	Bushing 1/4" i.d. x 1" o.d. x 3/4" lg (welded)	2	2
84	160-16611	Aluminium bronze bushing 1 3/4" o.d. x 1 1/4" i.d. x 1/2" lg	1	1
85	110-23352	Sprocket #80 + shearplate (including no.84 & no. 129)	1	1
86	UC207-20	Bearing 1 1/4"	1	1
87	FD207	Flange for 2 grease fitting	1	1
88	130-33221	Spacer plate	1	1
89	130-33231	Drive shaft access plate	1	1
90	300-40325	Bolt 1/2" NC x 1 3/4" lg + nylon locknut & flat washer 7/16"	4	4

SNOWBLOWERS PXPL-86 PXPL-86-92 (cont'd)

REF.	PART #	DESCRIPTION	QTY	
			PXP-86	PXP-8692
91	300-40280	Bolt 1/2" NC x 1 1/4" lg + nylon locknut & flat washer 7/16"	4	4
92	140-14243	3-points side bar	2	2
93	110-15291	Hoses support	1	1
94	300-44355	Bolt 5/8" NC x 2 1/4" lg + nylon locknut	2	2
95	150-05961	Pin category 2 (top link)	1	1
96	Std.	Lynch pin 1/4" x 1 3/4"	3	3
97	8202	P.T.O. shaft T60	1	1
97	9225-1	P.T.O. shaft T80	opt.	opt.
98	110-23133	Left lower hitch	1	1
99	110-23134	Right lower hitch	1	1
100	300-44520	Bolt 5/8" NC x 5" lg + nylon locknut	2	2
101	300-44550	Bolt 5/8" NC x 5 1/2" lg + nylon locknut	2	2
102	300-44490	Bolt 5/8" NC x 4 1/2" lg + nylon locknut	2	2
103	9269	Pin category 2	2	2
104	140-10871	3-points hitch reinforcement	1	1
105	300-40310	Bolt 1/2" NC x 1 1/2" lg + nylon locknut	2	2
106	9473	Compression spring	1	1
107	110-10271	Threaded tube for idler adjustment	1	1
108	8374	Adjustable clamp fastener (welded)	1	1
109	8375	Hook for adjustable clamp fastener (welded)	1	1
110	110-25891	Side shaft guard	1	1
111	300-46385	Bolt 3/4" NC x 2 3/4" lg + nylon locknut	2	2
112	Std.	Grease fitting 90°	2	2
113	110-23291	Threaded rod for idler adjustment + nut 7/16" NC	1	1
114	160-06511	Spacer 3/4" i.d. x 1 1/4" o.d. x 3/4" lg	2	2
115	150-00332	Idler clevis pin	1	1
116	110-23121	Idler	1	1
117	376-44000	Flat washer 5/8"	1	1
118	346-45000	Nylon locknut 5/8" NC thin	1	1
119	190-02321	Hose 3/8" x 55" lg + 1 fitting 6U-106 + 1 fitting 6U-108	-	2
119	190-07201	Hose 3/8" x 52" lg + 1 fitting 6U-106 + 1 fitting 6U-108	2	-
120	190-07061	Hose 3/8" x 65" lg + 1 fitting 6U-106 + 1 fitting 6U-108	-	2
120	190-07211	Hose 3/8" x 62" lg + 1 fitting 6U-106 + 1 fitting 6U-108	2	-
121	UCFD207-20	Bearing 1 1/4" + flange with 2 grease fitting	1	1
122	358-50500	Castle nut 1"-14 x 9/16" thick	2	2
123	15855x8	"T" adaptor 1/2" swivel	3	3
124	140-08882	Valve support (JL-50) up to serial # 24724	1	1
124	140-20601	Valve support (RL-50) from serial # 24725 and up	1	1
125	140-09401	Plate 1/4" x 2" x 4 5/16"	1	1
126	300-32325	Bolt 1/4" NC x 1 3/4" lg + nylon locknut	2	2
127	8351	Relief valve 1/2" (JL-50) up to serial # 24724	1	1
127	8380	Relief valve 1/2" (RL-50) from serial # 24725 and up	1	1
128	300-38400	Bolt 7/16" NC x 3" lg + nylon locknut	2	2
129	160-16591	Aluminium-bronze bushing 1 3/4 o.d. x 1 1/4 i.d. x 1 1/4" lg	1	1
130	160-03942	Spacer 1 5/8" o.d. x 1 1/4" i.d. x 5/32" thickness	1	1
131	150-07971	Washer 1 1/4" o.d. x 1/2" i.d. x 17/32" thickness	2	2
132	9405-06-06	Elbow 90° 3/8" swivel	2	2

SNOWBLOWERS PXPL-92 PXPL-92-98

170-03601R3

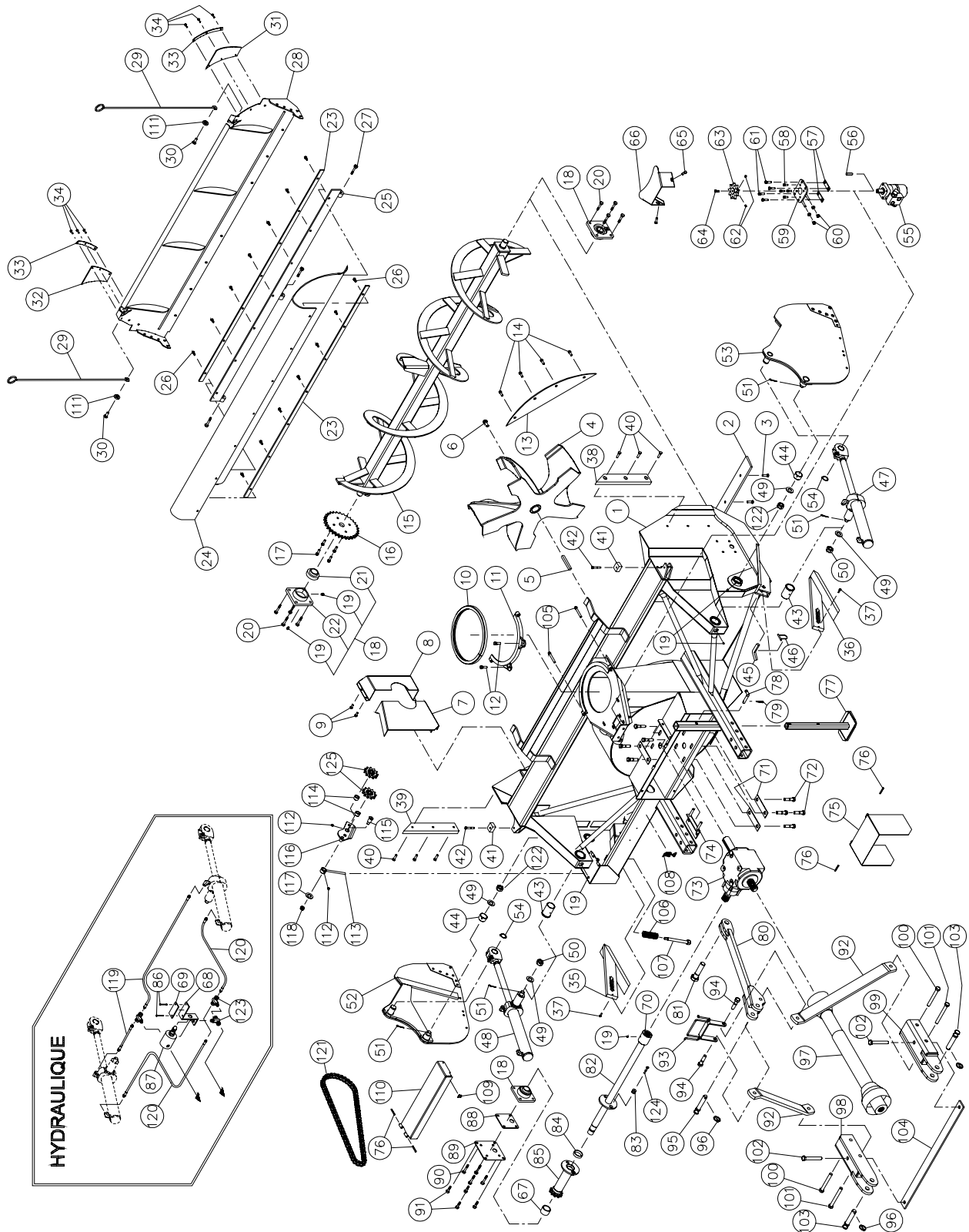

SNOWBLOWERS PXPL-92 PXPL-92-98 (cont'd)

REF.	PART #	DESCRIPTION	QTY	
			PXP-92	PXP-9298
1	120-05051	Frame PXPL-92	1	-
1	120-04851	Frame PXPL-9298	-	1
2	140-00812	Reversible scraper blade 1/2" x 4" x 84 1/2" lg	1	-
2	140-00832	Reversible scraper blade 1/2" x 4" x 90 1/2" lg	-	1
3	319-38310	Plow bolt 7/16" NC x 1 1/2" lg + nut & lock washer	9	9
4	110-25371	Impeller 32" dia. 5 blades	1	1
5	9285	Key 1/2" x 1/2" x 4"	1	1
6	300-44310	Bolt 5/8" NC x 1 1/2" lg (ass. with lock-tite 242) + lock washer	1	1
7	130-39541	Inside guard (welded)	1	1
8	130-39551	Inside guard (bolted)	1	1
9	300-36250	Boulon 3/8" NC x 1" lg + nylon locknut & flat washer	4	4
10	8149	U-shaped UHMW	1	1
11	110-01341	Retaining bracket	1	1
12	300-40310	Bolt 1/2" NC x 1 1/2" lg + nylon locknut & flat washer	2	2
13	130-39581	Deflector	1	1
14	301-38280	Bolt 7/16" NC x 1 1/4" lg + nylon locknut	4	4
15	110-25991	Auger PXPL-92	1	-
15	110-25361	Auger PXPL-9298	-	1
16	9281	Sprocket 80A30 T 1 1/2" dia.	1	1
17	300-38310	Bolt 7/16" NC x 1 1/2" lg + two way locknut	4	4
18	UCFD208-24	Bearing 1 1/2" + flange & grease fitting (straight)	3	3
19	Std.	Grease fitting 1/4"-28 straight	10	10
20	300-40325	Bolt 1/2" NC x 1 3/4" lg + nylon locknut & flat washer 7/16"	8	8
21	UC208-24	Bearing 1 1/2"	3	3
22	FD208	Flange for 2 grease fitting	3	3
23	140-07291	Back plate for shroud hinge and stationary hold down 1/4" x 1" x 71" (PXPL-92) .	2	-
23	140-06431	Back plate for shroud hinge and stationary hold down 1/4" x 1" x 77" (PXPL-9298) ...	-	2
24	190-07221	Shroud 35" x 71" (PXPL-92)	1	-
24	190-02522	Shroud 35" x 77" (PXPL-9298)	-	1
25	110-09532	Shroud hinge 71" (PXPL-92)	1	-
25	110-23222	Shroud hinge 77" (PXPL-9298)	-	1
26	300-34280	Bolt 5/16" NC x 1 1/4" lg + nylon locknut	16	16
27	300-38400	Bolt 7/16" NC x 3" lg + nylon locknut	3	3
28	110-25962	Plow PXPL-92	1	-
28	110-25392	Plow PXPL-9298	-	1
29	190-02193	Proximity indicator	2	2
30	300-40310	Bolt 1/2" NC x 1 1/2" lg + nylon locknut	2	2
31	190-02221	Right flap	1	1
32	190-02222	Left flap	1	1
33	140-06161	Flap hold down 1/8" x 1" x 10" lg	2	2
34	300-32250	Bolt 1/4" NC x 1" lg + nylon locknut & flat washer	6	6
35	110-04521	Skid shoe (left)	1	1
36	110-04531	Skid shoe (right)	1	1
37	300-32310	Bolt 1/4" x 1 1/2" lg + nylon locknut	2	2
38	190-07302	Right hand guide	1	1
39	190-07301	Left hand guide	1	1
40	319-38325	Plow bolt 7/16" NC x 1 3/4" lg + nylon locknut	6	6
41	190-07031	Stopper shock absorber	2	2

SNOWBLOWERS PXPL-92 PXPL-92-98 (cont'd)

REF.	PART #	DESCRIPTION	QTY	
			PXP-92	PXP-9298
42	302-36370	Bolt 3/8" NC x 2 1/2" lg + nylon locknut	2	2
43	160-12041	Bushing 2" i.d. x 2 1/2" o.d. x 3 3/8" lg	2	2
44	160-12001	Skid shoes lock	2	2
45	140-03361	Cran d'arrêt pour patin	2	2
46	8112	Lock pin 1/4"	2	2
47	25J15.5D	Hydraulic cylinder (right) 2 1/2" x 15 1/2" stroke (see page # 48)	1	1
48	25J15.5G	Hydraulic cylinder (left) 2 1/2" x 15 1/2" stroke (see page # 48)	1	1
49	376-50000	Flat washer 1" i.d. x 2 1/2" o.d.	4	4
50	358-50235	Castle nut 1"-14 x 7/8" thick	2	2
51	Std.	Cutter pin 5/32" x 2" lg	4	4
52	110-25423	Pivoting side (left)	1	1
53	110-25424	Pivoting side (right)	1	1
54	Std.	External retaining ring 1 1/2"	2	2
55	MLH-315	«Orbit» hydraulic motor + cushion valve	opt	opt
56	8369	Key for hydraulic motor	1	1
57	140-09571	Spacer 1/8" x 1" x 3 1/4" lg for «Orbit» motor	2	2
58	300-36250	Bolt 3/8" NC x 1" lg + lock washer	4	4
59	110-20811	«Orbit» motor support	1	1
60	336-38000	Nut 7/16" NC	4	4
61	300-38310	Bolt 7/16" NC x 1 1/2" lg + nylon locknut & flat washer	4	4
62	323-36160	Hexagonal socket set screw 3/8" NC x 3/8" lg	2	2
63	110-04182	Sprocket 9 tooth	1	1
64	300-32220	Bolt 1/4" NC x 3/4" lg + lock washer	1	1
65	300-38280	Bolt 7/16" NC x 1 1/4" lg + nylon locknut & flat washer	2	2
66	130-08162	Guard	1	1
67	160-07311	Aluminium-bronze bushing 1 1/2" i.d. x 1 7/8" o.d. x 1 1/4" lg	1	1
68	140-08882	Valve support (JL-50) up to serial # 24724	1	1
68	140-20601	Valve support (RL-50) from serial # 24725 and up	1	1
69	140-09401	Plate 1/4" x 2" x 4 5/16"	1	1
70	6467	Splined adaptor 1 3/4"-20 splines (welded)	1	1
71	140-10761	Back plate	3	3
72	300-44280	Bolt 5/8" NC x 1 1/4" lg + lockwasher	8	8
73	9307	Gear box T279	1	1
74	110-05281	Adjustment plate for gear box + 4 nuts 1/2" NC	1	1
75	110-12541	Hinged P" T" O" shroud	1	1
76	Std.	Roll pin 5/16" x 2" lg	4	4
77	9462	Storage support	1	1
78	8220	Storage support pin	1	1
79	Std.	Hitch pin clip 5/32"	1	1
80	110-25381	Top link	1	1
81	300-54460	Bolt 1 1/4" NC x 4" lg + nylon locknut	1	1
82	110-25931	Auger drive shaft x 34 7/16" PXPL-92	1	-
82	110-18261	Auger drive shaft x 37 7/16" PXPL-9298	-	1
83	150-03911	Bushing 15/16" i.d. x 1" o.d. x 3/4" lg (welded)	2	2
84	160-06901	Aluminium-bronze bushing 1 3/4" i.d. x 2" o.d. x 1/2" lg	2	2
85	110-18241	Sprocket #80 + shearplate (including no.84 et 67)	1	1
86	300-32325	Bolt 1/4" NC x 1 3/4" lg + nylon locknut	2	2
87	8351	Relief valve 1/2" (JL-50) up to serial # 24724	1	1

SNOWBLOWERS PXPL-92 PXPL-92-98 (cont'd)

REF.	PART #	DESCRIPTION	QTY	
			PXP-92	PXP-9298
87	8380	Relief valve 1/2" (RL-50) from serial # 24725 and up	1	1
88	130-39271	Spacer plate	1	1
89	130-39261	Drive shaft access plate	1	1
90	300-40325	Bolt 1/2" NC x 1 3/4" lg + nylon locknut thin & flat washer 7/16"	4	4
91	300-40280	Bolt 1/2" NC x 1 1/4" lg + nylon locknut & flat washer 7/16"	4	4
92	140-15451	3-points side bar	2	2
93	110-15201	Hoses support	1	1
94	300-46400	Bolt 3/4" NC x 3" lg + nylon locknut	2	2
95	150-05961	Pin category 2 (top link)	1	1
96	Std.	Lynch pin 1/4" x 1 3/4"	3	3
97	9225-EG	P.T.O. shaft T80	1	1
97	9475	P.T.O. shaft T90	opt.	opt.
98	110-15213	Left lower hitch	1	1
99	110-15214	Right lower hitch	1	1
100	302-46580	Bolt 3/4" NF x 6" lg + nylon locknut	2	2
101	302-46610	Bolt 3/4" NF x 6 1/2" lg + nylon locknut	2	2
102	300-46550	Bolt 3/4" NC x 5 1/2" lg + nylon locknut	2	2
103	9269	Pin category 2	2	2
104	140-15461	3-points hitch reinforcement	1	1
105	300-38400	Bolt 7/16" NC x 3" lg + nylon locknut	2	2
106	9688	Compression spring	1	1
107	110-01071	Threaded tube for idler adjustment	1	1
108	8374	Adjustable clamp fastener (welded)	1	1
109	8375	Hook for adjustable clamp fastener (welded)	1	1
110	110-25431	Side shaft guard	1	1
111	150-07971	Washer 1 1/4" o.d. x 1/2" i.d. x 17/32" thick	2	2
112	Std.	Grease fitting 90°	2	2
113	110-01063	Threaded rod for idler adjustment + nut 7/16" NC	1	1
114	160-06511	Spacer 3/4" i.d. x 1 1/4" o.d. x 3/4" lg	2	2
115	150-00332	Idler clevis pin	1	1
116	110-01052	Idler	1	1
117	376-44000	Flat washer 5/8"	1	1
118	346-45000	Nylon locknut 5/8" NC thin	1	1
119	190-07251	Hose 3/8" x 53" lg + 1 fitting 6U-106 + 1 fitting 6U-108	-	2
119	190-07281	Hose 3/8" x 50" lg + 1 fitting 6U-106 + 1 fitting 6U-108	2	-
120	190-07261	Hose 3/8" x 68" lg + 1 fitting 6U-106 + 1 fitting 6U-108	-	2
120	190-07061	Hose 3/8" x 65" lg + 1 fitting 6U-106 + 1 fitting 6U-108	2	-
121	190-07271	Chain #80 x 75" lg (75 links)	1	1
121	26A80	Connecting link no.80	1	1
121	59-80	Offset link no.80	1	1
122	358-50500	Castle nut 1"-14 x 9/16" thick	2	2
123	15855x8	"T" adaptor 1/2" swivel	3	3
124	300-34340	Bolt 5/16" NC x 2" lg + nylon locknut	2	2
125	9287	Sprocket #80	2	2

CHUTE CST-7486

170-03271

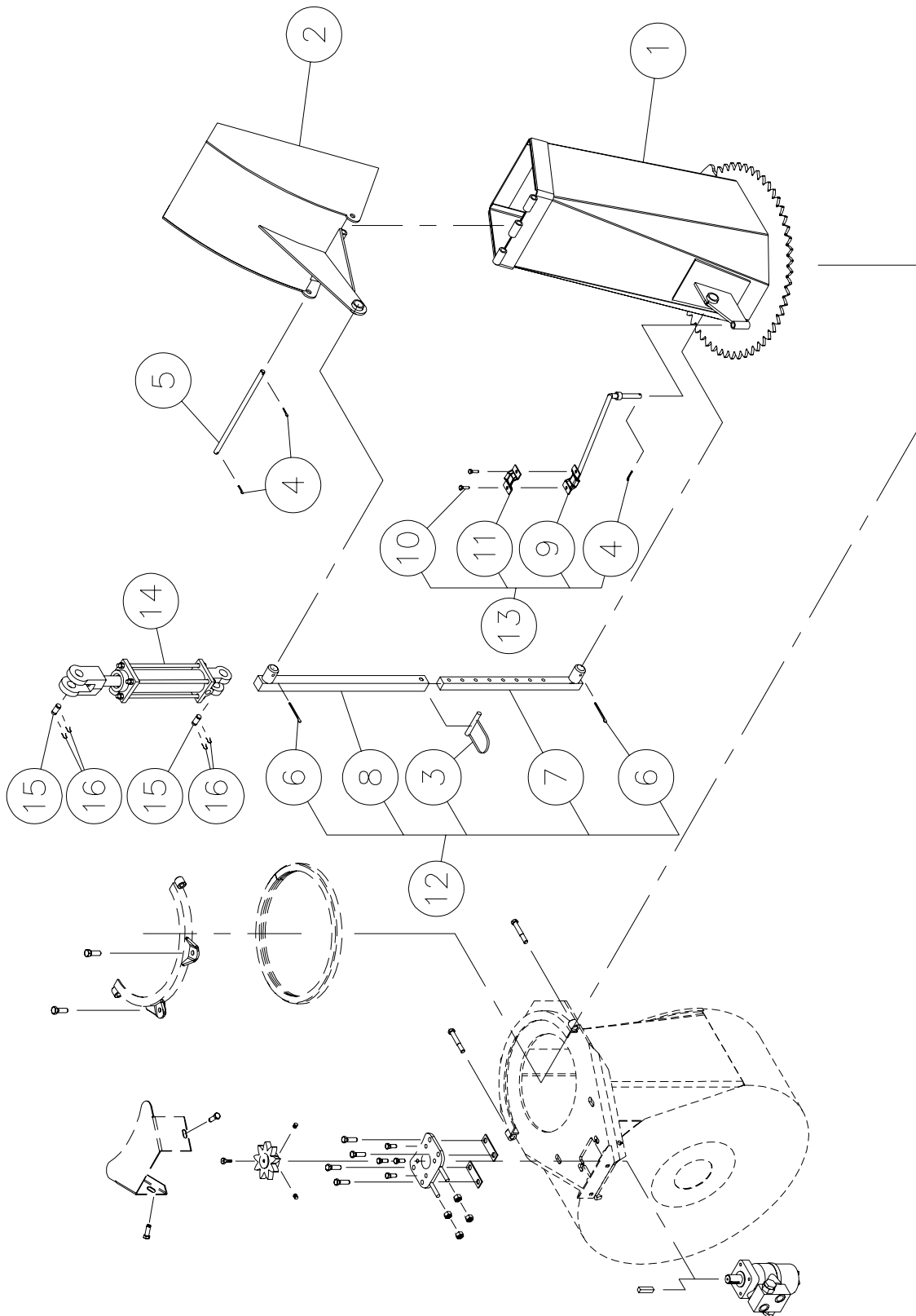

CHUTE CST-7486

REF.	PART #	DESCRIPTION	QTY
1	110-04401	Chute base	1
2	8370	Chute deflector	1
3	8112	Lock pin 1/4" (1)	opt.
4	Std.	Cotter pin 1/8" x 1" lg	3
5	8210	Chute deflector pin	1
6	Std.	Cotter pin 5/32" x 2" lg (2)	opt.
7	8145	Chute adjusting rod (1)	opt.
8	8146	Chute adjusting tube (1)	opt.
9	110-01112	Mounting support plate	1
10	300-32250	Bolt 1/4" NC x 1" lg. + nylon locknut	2
11	140-13071	Hoses mounting plate	1
12	T-74104	Manual telescopic tube	opt.
13	TSB-74104	Hose support for deflector cylinder	opt.
14	25TR08	Cylinder	opt.
15	6004	Clevis pin 1" x 3 1/8" lg (2)	opt.
16	Std.	Hairpin cotter 7/8" (4)	opt.

SEMI-INDUSTRIAL CHUTE PSIG-7486

170-03393

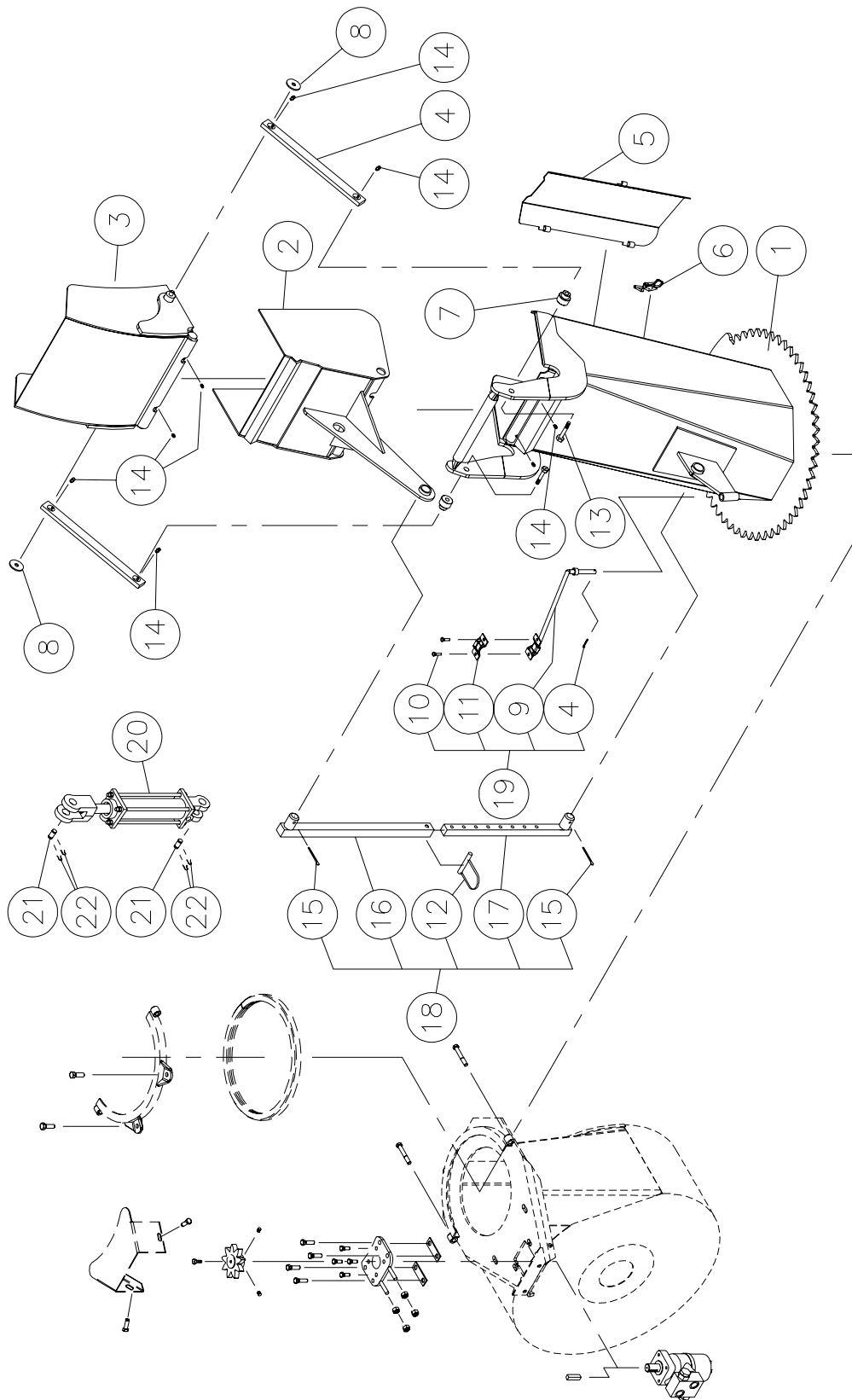

SEMI-INDUSTRIAL CHUTE PSIG -7486

REF.	PART #	DESCRIPTION	QTY
1	110-22503	Chute base	1
2	110-22521	Lower chute deflector	1
3	110-22511	Upper chute deflector	1
4	140-14041	Connecting rod	2
5	110-22893	Access panel	1
6	8376	Adjustable clamp fastener (welded)	1
7	150-05311	Spacer for connecting rod	2
8	378-36500	Washer	2
9	110-01112	Hoses support	1
10	300-32250	Bolt 1/4" NC x 1" lg + nylon locknut	2
11	140-13071	Hose hold down	1
12	8112	Lock pin 1/4" (1)	opt.
13	300-40380	Bolt 1/2" NC x 2 3/4" lg + nylon lock nut & washer	2
14	Std.	Grease fitting 1/4"-28 straight	8
15	Std.	Cotter pin 5/32" x 2" lg (2)	opt.
16	8146	Chute adjusting tube (1)	opt.
17	8145	Chute adjusting rod (1)	opt.
18	T-74104	Manual telescopic tube	opt.
19	TSB-74104	Hose support for deflector cylinder	opt.
20	25TR08	Cylinder	opt.
21	6004	Clevis pin 1" x 3 1/8" lg (2)	opt.
22	Std.	Hairpin cotter 7/8" (4)	opt.

SNOWBLOWER'S OPTIONS

170-03671R1

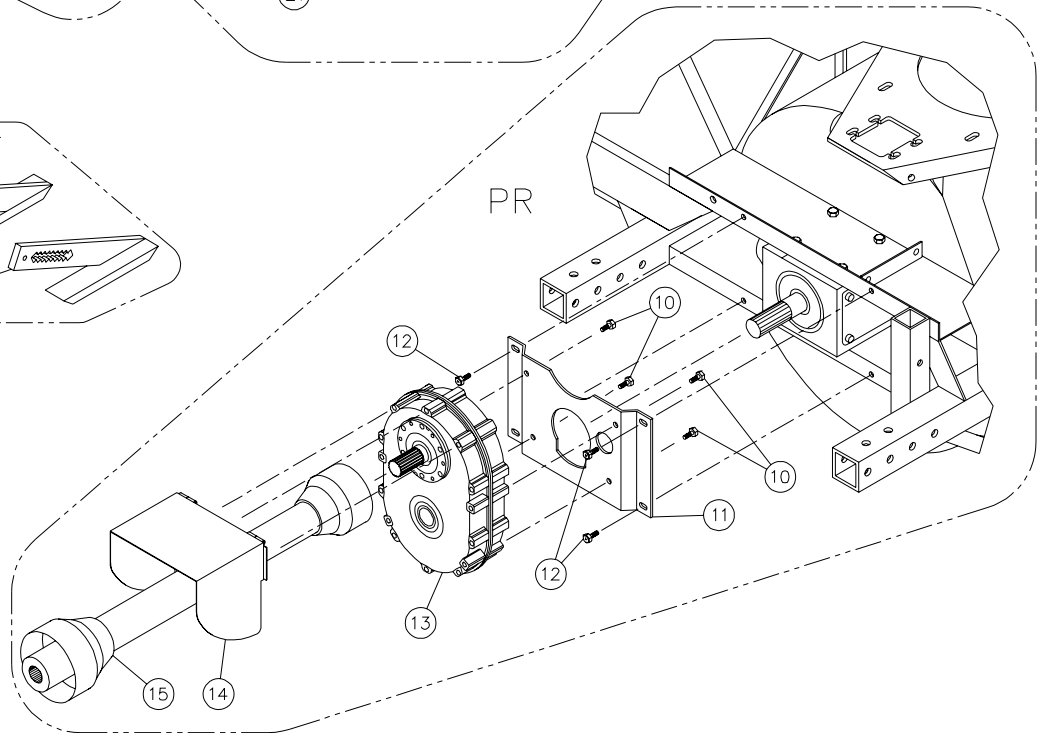
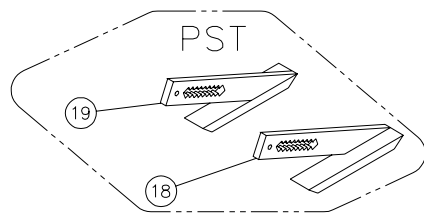
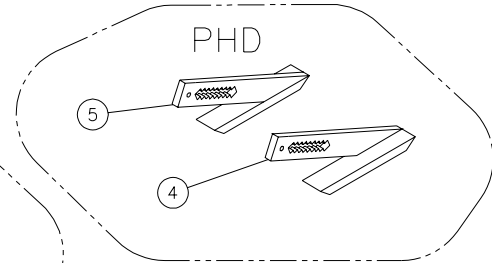
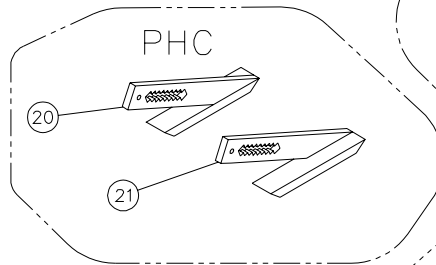
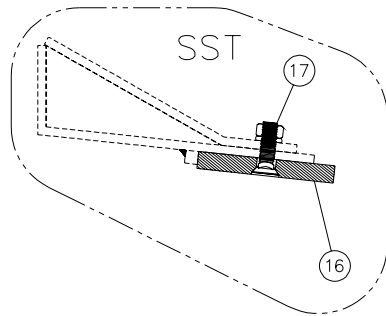
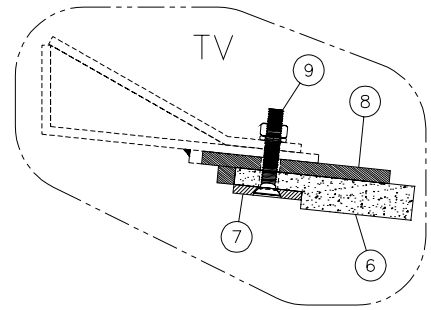
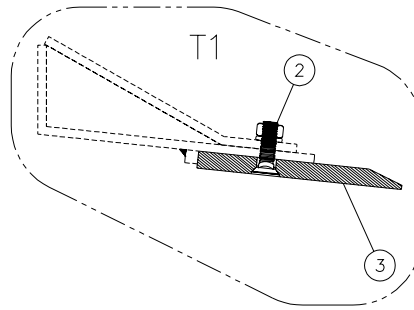
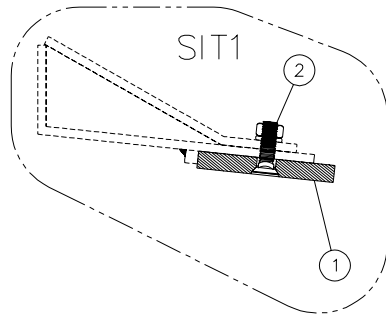

SNOWBLOWER'S OPTIONS

REF.	PART #	DESCRIPTION	QTY			
			PXPL-86	PXPL-86-92	PXPL-92	PXPL-92-98
1	140-04071	Scraper blade (hard. steel, not sharpened, reversible) 1/2" x 4" x 79 3/4" ..	1	-	-	-
1	140-13131	Scraper blade (hard. steel, not sharpened, reversible) 1/2" x 4" x 85 3/4" ..	-	1	-	-
1	140-04081	Scraper blade (hard. steel, not sharpened, reversible) 1/2" x 4" x 84 1/2" ..	-	-	1	-
1	140-04091	Scraper blade (hard. steel, not sharpened, reversible) 1/2" x 4" x 90 1/2" ..	-	-	-	1
2	319-38325	Plow bolt 7/16" NC x 1 3/4" lg + nut & lock washer	8	9	9	9
3	140-04131	Scraper blade (hardened steel, sharpened, not reversible) 1/2" x 6" x 79 3/4"	1	-	-	-
3	140-13141	Scraper blade (hardened steel, sharpened, not reversible) 1/2" x 6" x 85 3/4"	-	1	-	-
3	140-04141	Scraper blade (hardened steel, sharpened, not reversible) 1/2" x 6" x 84 1/2"	-	-	1	-
3	140-04151	Scraper blade (hardened steel, sharpened, not reversible) 1/2" x 6" x 90 1/2"	-	-	-	1
4	110-05501	Carbon steel skid shoe (right side)	1	1	-	-
4	110-05511	Carbon steel skid shoe (right side)	-	-	1	1
5	110-04681	Carbon steel skid shoe (left side)	1	1	-	-
5	110-04811	Carbon steel skid shoe (left side)	-	-	1	1
6	190-01311	Scraper blade, TIVAR not reversible 1" x 5 1/4" x 79 3/4"	1	-	-	-
6	190-05681	Scraper blade, TIVAR not reversible 1" x 5 1/4" x 85 3/4"	-	1	-	-
6	190-01331	Scraper blade, TIVAR not reversible 1" x 5 1/4" x 84 1/2"	-	-	1	-
6	190-01321	Scraper blade, TIVAR not reversible 1" x 5 1/4" x 90 1/2"	-	-	-	1
7	140-03971	TIVAR blade bolting plate 1/4" x 2" x 79 3/4"	1	-	-	-
7	140-13151	TIVAR blade bolting plate 1/4" x 2" x 85 3/4"	-	1	-	-
7	140-03991	TIVAR blade bolting plate 1/4" x 2" x 84 1/2"	-	-	1	-
7	140-03981	TIVAR blade bolting plate 1/4" x 2" x 90 1/2"	-	-	-	1
8	110-08321	TIVAR blade holder 3/8" x 5 1/2" x 79 3/4"	1	-	-	-
8	110-20581	TIVAR blade holder 3/8" x 5 1/2" x 85 3/4"	-	1	-	-
8	110-10391	TIVAR blade holder 3/8" x 5 1/2" x 84 1/2"	-	-	1	-
8	110-10381	TIVAR blade holder 3/8" x 5 1/2" x 90 1/2"	-	-	-	1
9	319-38370	Plow bolt 7/16" NC x 2 1/2" lg + nut & lock washer	8	9	9	9
10	300-40200	Bolt 1/2" NC x 3/4" lg + lock washer	4	4	-	-
10	300-40280	Bolt 1/2" NC x 1 1/4" lg + lock washer	-	-	4	4
11	130-16683	Mounting plate for speed reducer 1000 @ 540	1	1	-	-
11	130-19521	Mounting plate for speed reducer 1000 @ 540	-	-	1	1
12	300-40310	Bolt 1/2" NC x 1 1/2" lg + nylon locknut & flat washer (x)	4	4	4	4
13	8348	Speed reducer 1000@540 "triple chain"	1	1	-	-
13	9575	Speed reducer 1000@540 "triple chain"	-	-	1	1
14	110-12961	PTO shroud for speed reducer 1000@540	1	1	1	1
15	8202-1	P.T.O. T60,QD 1 3/8"-21 splines, SBI 1 3/8"-6	1	1	-	-
15	9569	P.T.O. T80,QD 1 3/8"-21 splines, SBI 1 3/4"-20	-	-	1	1
15	9569-1	P.T.O. T80,QD 1 3/8"-20 splines, SBI 1 3/4"-20	-	-	1	1
15	9475-1	P.T.O. T90,QD 1 3/8"-21 splines, SBI 1 3/4"-20	-	-	1	1
15	9475-2	P.T.O. T90,QD 1 3/8"-20 splines, SBI 1 3/4"-20	-	-	1	1
16	140-15021	Stainless steel scraper blade (not sharpened, reversible) 1/2" x 4" x 79 3/4" ..	1	-	-	-
16	140-15031	Stainless steel scraper blade (not sharpened, reversible) 1/2" x 4" x 85 3/4" ..	-	1	-	-
16	140-15041	Stainless steel scraper blade (not sharpened, reversible) 1/2" x 4" x 84 1/2" ..	-	-	1	-
16	140-15051	Stainless steel scraper blade (not sharpened, reversible) 1/2" x 4" x 90 1/2" ..	-	-	-	1
17	333-40310	Hex. socket head set screw 1/2" NC x 1 1/2" lg (stainless steel)+ nut & lock washer	opt.	opt.	-	-
17	333-40340	Hex.l socket head set screw 1/2" NC x 2" lg (stainless steel)+ nut & lock washer	-	-	opt.	opt.
17	319-38310	Plow bolt 7/16" NC x 1 1/2" lg + nut & lock washer	8	9	-	-
17	319-38325	Plow bolt 7/16" NC x 1 3/4" lg + nut & lock washer	-	-	9	9
18	110-24811	Stainless steel skid shoe (right)	1	1	-	-
18	110-24831	Stainless steel skid shoe (right)	-	-	1	1
19	110-24812	Stainless steel skid shoe (left)	1	1	-	-
19	110-24832	Stainless steel skid shoe (left)	-	-	1	1
20	110-32861	Skid shoe (left side) with carbide sole	1	1	-	-
20	110-32871	Skid shoe (left side) with carbide sole	-	-	1	1
21	110-32862	Skid shoe (right side) with carbide sole	1	1	-	-
21	110-32872	Skid shoe (right side) with carbide sole	-	-	1	1

X-PRO BLADE'S OPTIONS

170-03661R1

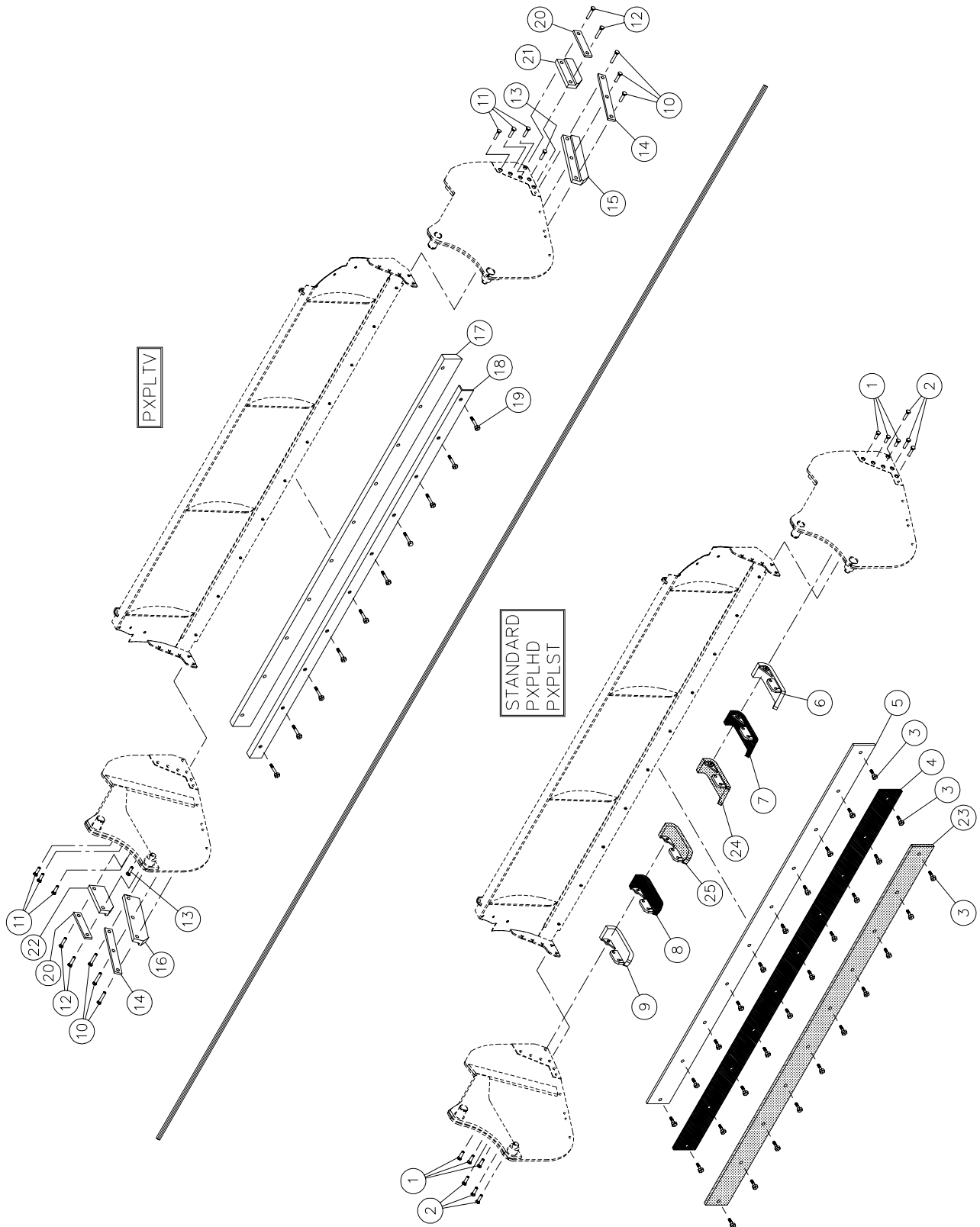

X-PRO BLADE'S OPTIONS

SCRAPER BLADE & SKID SHOE (Standard steel)

REF.	PART #	DESCRIPTION	QTY		
			Standard	86	92 98
1	319-38310	Flow bdt 7/16" NCx 1 1/2" lg+ nut & lock washer	6	6	6
2	319-38340	Flow bdt 7/16" NCx 2" lg+ nut & lock washer	6	6	6
3	300-38310	Bdt 7/16" NCx 1 1/2" lg+ nylon locknut	8	9	10
5	140-15811	Standard steel scraper blade 1/2" x 4" x 80 1/2" lg	1	-	-
5	140-14391	Standard steel scraper blade 1/2" x 4" x 86 1/2" lg	-	1	-
5	140-15471	Standard steel scraper blade 1/2" x 4" x 92 1/2" lg	-	-	1
6	110-22284	Standard steel skid shoe (right)	1	1	1
9	110-22283	Standard steel skid shoe (left)	1	1	1

SCRAPER BLADE & SKID SHOE PXPLHD (CHT360 steel)

REF.	PART #	DESCRIPTION	QTY		
			PXPLHD	86	92 98
1	319-38310	Flow bdt 7/16" NCx 1 1/2" lg+ nut & lock washer	6	6	6
2	319-38340	Flow bdt 7/16" NCx 2" lg+ nut & lock washer	6	6	6
3	300-38310	BOLT 7/16" NCx 1 1/2" lg+ nylon locknut	8	9	10
4	130-40991	CHT360 steel scraper blade 1/2" x 4" x 80 1/2" lg	1	-	-
4	130-41001	CHT360 steel scraper blade 1/2" x 4" x 86 1/2" lg	-	1	-
4	130-41011	CHT360 steel scraper blade 1/2" x 4" x 92 1/2" lg	-	-	1
7	110-23534	CHT360 steel skid shoe (right)	1	1	1
8	110-23533	CHT360 steel skid shoe (left)	1	1	1

SCRAPER BLADE & SKID SHOE PXPLTV (TIVAR)

REF.	PART #	DESCRIPTION	QTY		
			PXPLTV	86	92 98
10	327-38325	Hexagonal socket head set screw 7/16" NCx 1 3/4" lg+ nut (thin)	3	3	3
11	319-38310	Flow bdt 7/16" NCx 1 1/2" lg+ nut & lock washer	8	8	8
12	319-38370	Flow bdt 7/16" NCx 2 1/2" lg+ nut & lock washer	2	2	2
13	319-38340	Flow bdt 7/16" NCx 2" lg+ nut & lock washer	6	6	6
14	140-08831	TIVAR skid shoe holder 5/16" x 1 1/4" x 11 5/8" lg	2	2	2
15	190-03352	TIVAR skid shoe 11 5/8" lg (right)	1	1	1
16	190-03351	TIVAR skid shoe 11 5/8" lg (left)	1	1	1
17	190-07171	TIVAR scraper blade 1" x 3 1/4" x 87" lg	1	-	-
17	190-02402	TIVAR scraper blade 1" x 3 1/4" x 93" lg	-	1	-
17	190-02312	TIVAR scraper blade 1" x 3 1/4" x 99" lg	-	-	1
18	130-40591	Holder 83 3/16" lg for TIVAR scraper blade	1	-	-
18	130-40601	Holder 89 3/16" lg for TIVAR scraper blade	-	1	-
18	130-40631	Holder 95 3/16" lg for TIVAR scraper blade	-	-	1
19	300-38355	Bdt 7/16" NCx 2 1/4" lg+ nylon locknut	8	9	10
20	140-08842	TIVAR skid shoe holder 5/16" x 1 1/4" x 6 7/16" lg	2	2	2
21	190-03364	TIVAR skid shoe 6 7/16" lg (right)	1	1	1
22	190-03363	TIVAR skid shoe 6 7/16" lg (left)	1	1	1

SCRAPER BLADE & SKID SHOE PXPLST (Stainless Steel)

REF.	PART #	DESCRIPTION	QTY		
			PXPLST	86	92 98
1	319-38310	Flow bdt 7/16" NCx 1 1/2" lg+ nut & lock washer	6	6	6
2	319-38340	Flow bdt 7/16" NCx 2" lg+ nut & lock washer	6	6	6
3	300-38310	BOLT 7/16" NCx 1 1/2" lg+ nylon locknut	9	9	10
23	130-42811	Stainless steel scraper blade 1/2" x 4" x 80 1/2" lg	1	-	-
23	130-42821	Stainless steel scraper blade 1/2" x 4" x 86 1/2" lg	-	1	-
23	130-42831	Stainless steel scraper blade 1/2" x 4" x 92 1/2" lg	-	-	1
24	110-26872	Stainless steel skid shoe (right)	1	1	1
25	110-26871	Stainless steel skid shoe (left)	1	1	1

10

P.T.O. SHAFT # 8202 & 8202-1 (T60)

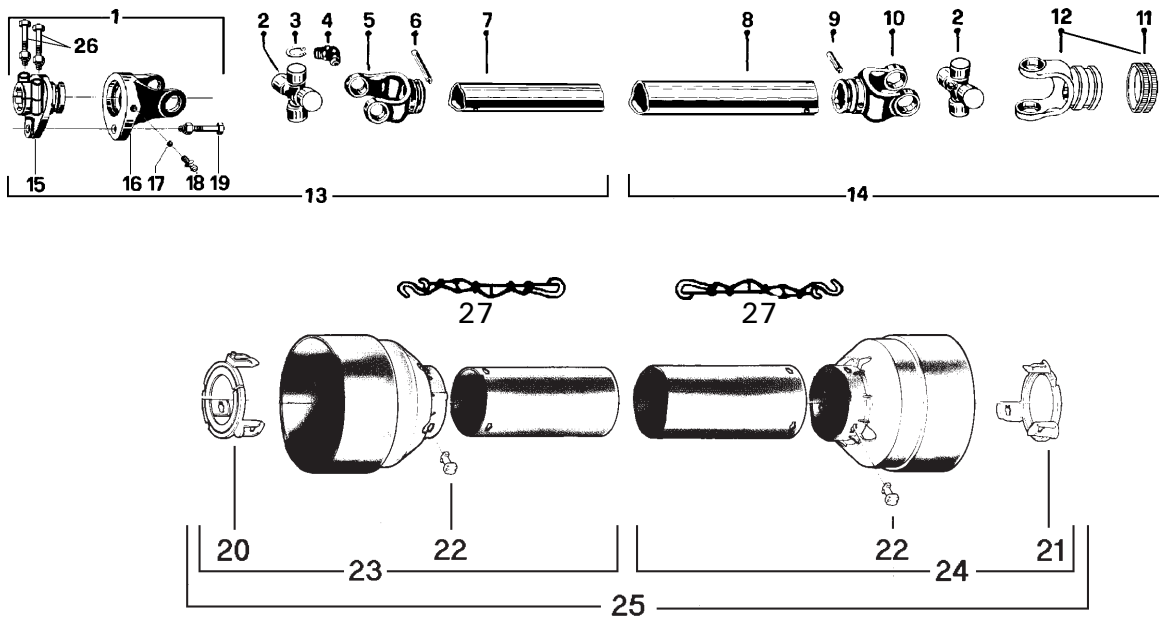

REF.	PART #	DESCRIPTION	8202	8202-1
1	8237	Safety shear yoke (2 bolts)	1	1
2	8238	U joint + 4 retaining rings + 1 grease fitting	2	2
3	8061	Retaining ring	8	8
4	8110	Grease fitting	2	2
5	8239	Yoke for inner tube	1	1
6	8075	Stopper for inner tube	1	1
7	8077	Inner tube	1	1
8	9212	Outer tube	1	1
9	9210-E	Stopper for outer tube	1	1
10	8240	Yoke for outer tube	1	1
11	8363	Collar kit	1	1
12	8250	Yoke with hole 1 3/8"-6 splines + yoke stopper (#11 included)	1	-
12	8250-1	Yoke with hole 1 3/8"-21 splines + yoke stopper (#11 included)	-	1
13	8241	P.T.O. section, SBI 1 3/8"-6, inner part, without protector	1	1
14	8242	P.T.O. section, QD 1 3/8"-6, outer part, without protector	1	-
14	8242-1	P.T.O. section, QD 1 3/8"-21, outer part, without protector	-	1
15	8243	Adaptor (2 bolts)	1	1
16	8244	Yoke and shearplate	1	1
17	9205	Ball	17	17
18	8071	Grease fitting	1	1
19	8218	Safety shear bolt M10 x 60mm	1	1
20	8245	Bearing ring for inner guard tube	1	1
21	8246	Bearing ring for outer guard tube	1	1
22	8109	Stopper	6	6
23	8247	Inner shield	1	1
24	8248	Outer shield	1	1
25	8249	Complete shield	1	1
26	8222	Bolt M12 x 70mm + lock nut	2	2
27	8308	Safety chain	2	2

P.T.O. SHAFT # 9225-EG, 9225-1 & 9569 (T80)

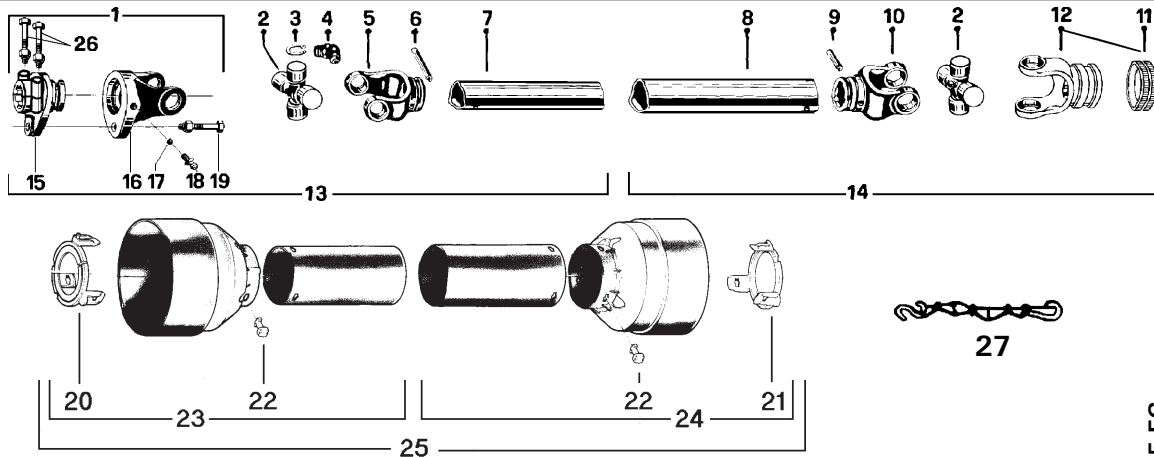

REF.	PART #	DESCRIPTION	9225-EG	9225-1	9569
1	9453	Safety shear yoke M12 (2 bolts) 1 3/4" - 20 splines	1	-	-
1	9464-2	Safety shear yoke M10 (2 bolts) 1 3/8" - 6 splines	-	1	-
or [1	9570	Safety shear yoke M10 (2 bolts) 1 3/4" - 20 splines	-	-	1
or [1	9453	Safety shear yoke M12 (2 bolts) 1 3/4" - 20 splines	-	-	1
2	9208	U-joint + 4 retaining rings + 1 grease fitting	2	2	2
3	9454	Retaining ring	8	8	8
4	8110	Grease fitting	2	2	2
5	9214	Yoke for inner tube	1	1	1
6	8075	Stopper for inner tube	1	1	1
7	9212	Inner tube	1	1	1
8	9211	Outer tube	1	1	1
9	9210-E	Stopper for outer tube	1	1	1
10	9209	Yoke for outer tube	1	1	1
11	8363	Collar kit	1	1	1
11	8364	Collar kit	-	-opt.	-
12	9455	Yoke with hole 1 3/8"-6 splines + yoke stopper	1	1	-
12	9463	Yoke with hole 1 3/8"-21 splines + yoke stopper	-	-	1
12	9224	Yoke with hole 1 3/4"-20 splines + yoke stopper	-	-opt.	-
13	9456	P.T.O. section, SBI 1 3/4"-20, inner part, without protector	1	-	1
13	9456-1	P.T.O. section, SBI 1 3/8"-6, inner part, without protector	-	1	-
14	9457	P.T.O. section, QD 1 3/8"-6, outer part, without protector	1	1	-
14	9457-2	P.T.O. section, QD 1 3/8"-21, outer part, without protector	-	-	1
15	9458	Adaptor 1 3/4"-20 splines (2 bolts) (hole 12 mm)	1	-	-
15	9458-2	Adaptor 1 3/8"-6 splines (2 bolts) (hole 10 mm)	-	1	-
or [15	9458	Adaptor 1 3/4"-20 splines (2 bolts) (hole 12 mm)	-	-	1
or [15	9571	Adaptor 1 3/4"-20 splines (2 bolts) (hole 10 mm)	-	-	1
16	9204	Yoke and shearplate (hole 12 mm)	1	-	-
16	9572	Yoke and shearplate (hole 10 mm)	-	1	-
or [16	9572	Yoke and shearplate (hole 10 mm)	-	-	1
or [16	9204	Yoke and shearplate (hole 12 mm)	-	-	1
17	9205	Ball	17	17	17
18	8071	Grease fitting	1	1	1
19	9207	Safety shear bolt M12 x 65 mm	1	-	-
19	8218	Safety shear bolt M10 x 60 mm	-	1	-
or [19	9207-375	Safety shear bolt M12 x 65 mm diam. 3/8"	-	-	1
or [19	8218	Safety shear bolt M10 x 60 mm	-	-	1
20	9459	Bearing ring for inner guard tube	1	1	1
21	9460	Bearing ring for outer guard tube	1	1	1
22	8109	Stopper	6	6	6
23	9221	Inner shield	1	1	1
24	9220	Outer shield	1	1	1
25	9222	Complete shield	1	1	1
26	9461	Bolt M12 x 90mm + lock nut	2	-	2
26	8222	Bolt M12 x 70mm + lock nut	-	2	-
27	8308	Safety chain	2	2	2

10

P.T.O. SHAFT # 9475, 9475-1 & 9475-2 (T90)

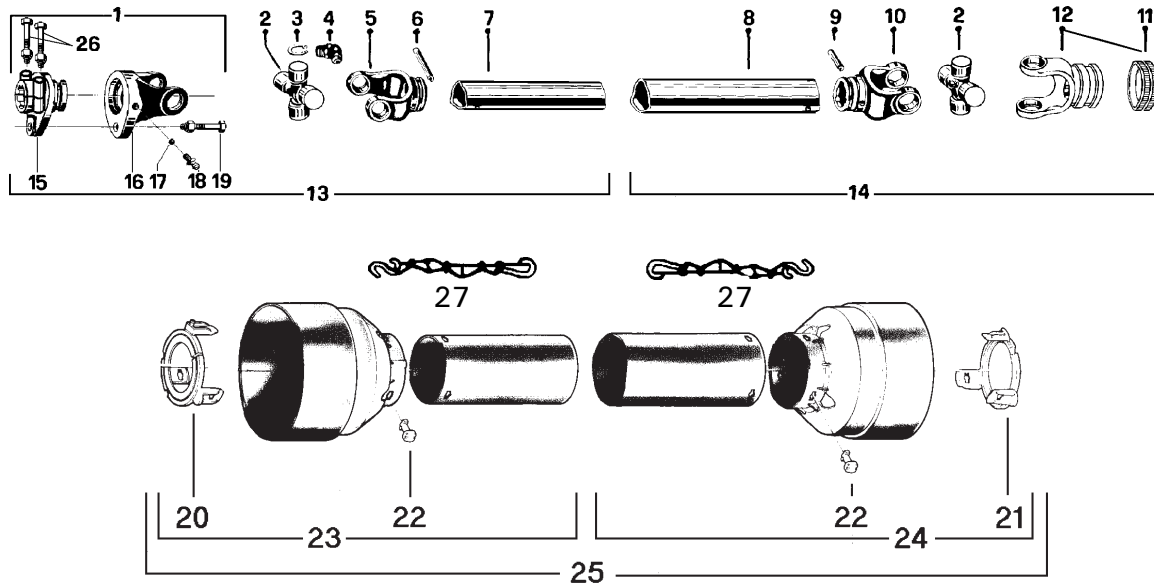

REF.	PART #	DESCRIPTION	QTY		
			9475	9475-1	9475-2
1	9476	Safety shear yoke (2 bolts) 1 3/4" - 20 splines	1	1	1
2	9477	U-joint + 4 retaining rings + 1 grease fitting	2	2	2
3	9478	Retaining ring	8	8	8
4	8110	Grease fitting	2	2	2
5	9479	Yoke for inner tube	1	1	1
6	9210	Stopper for tube	1	1	1
7	9212	Inner tube	1	1	1
8	9211	Outer tube	1	1	1
9	9210	Stopper for tube	1	1	1
10	9480	Yoke for outer tube	1	1	1
11	8363	Collar kit	1	1	-
11	8364	Collar kit	-	-	1
12	9481	Yoke with hole 1 3/8"-6 splines + yoke stopper	1	-	-
12	9482	Yoke with hole 1 3/8"-21 splines + yoke stopper	-	1	-
12	9483	Yoke with hole 1 3/4"-20 splines + yoke stopper	-	-	1
13	9484	P.T.O. section, SBI 1 3/4"-20, inner part, without protector	1	1	1
14	9485	P.T.O. section, QD 1 3/8"-6, outer part, without protector	1	-	-
14	9485-1	P.T.O. section, QD 1 3/8"-21, outer part, without protector	-	1	-
14	9485-2	P.T.O. section, QD 1 3/4"-20, outer part, without protector	-	-	1
15	9486	Adaptor 1 3/4"-20 splines (2 bolts)	1	1	1
16	9487	Yoke and shearplate	1	1	1
17	9205	Ball	24	24	24
18	8071	Grease fitting	1	1	1
19	9207	Safety shear bolt M12 x 65mm	1	-	-
19	9207-375	Safety shear bolt M12 x 65mm diam 3/8"	-	1	1
20	9459	Bearing ring for inner guard tube	1	1	1
21	9460	Bearing ring for outer guard tube	1	1	1
22	8109	Stopper	6	6	6
23	9221	Inner shield	1	1	1
24	9220	Outer shield	1	1	1
25	9222	Complete shield	1	1	1
26	8222	Bolt M12 x 70mm + lock nut	2	2	2
27	8308	Safety chain	2	2	2

GEAR BOX # 8251 (T27D)

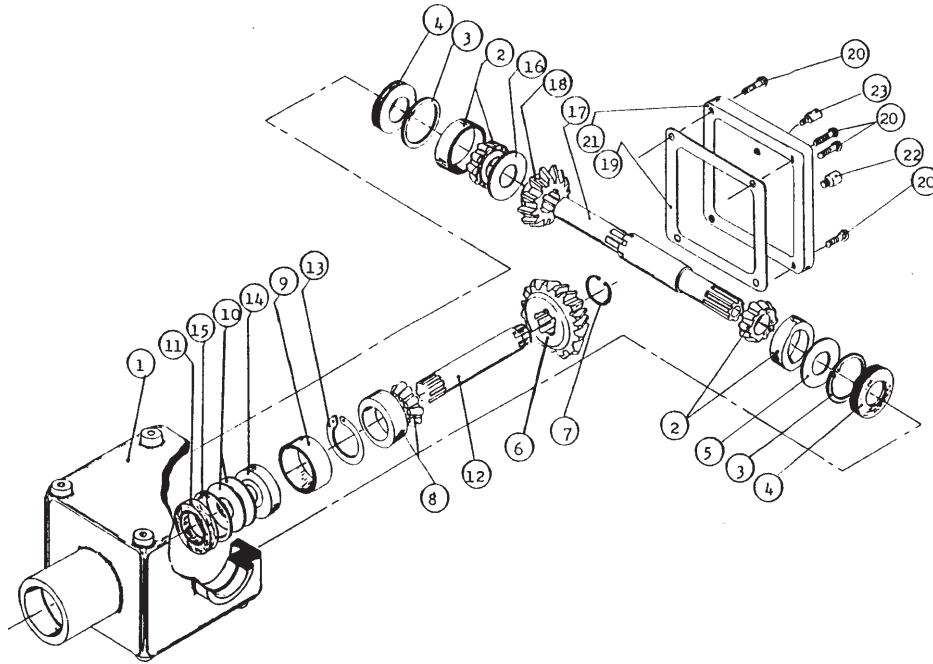

REF.	PART #	DESCRIPTION	QTY
1	8043	Casing	1
2	30208-A	Roller bearing	2
3	8045	Inside circlip 80mm	2
4	8046	Oil seal 40 x 80 x 12mm	2
5	8047	Adjusting washer	1
6	8048	Gear Z18	1
7	8049	Outside circlip 40mm	1
8	30207-A	Roller bearing	1
9	8051	Spacer ring	1
10	8052	Adjusting washer	2
11	8053	Oil seal 35 x 72 x 12mm	1
12	8054	Side shaft (1 1/4" - 19 splines)	1
13	8055	Inside circlip 72mm	1
14	6207-2RS	Ball bearing	1
15	8057	Outside circlip 35mm	1
16	8058	Adjusting washer	1
17	8252	Impeller shaft (1.575" & 1 3/8" - 6 splines)	1
18	8060	Gear Z-18	1
19	- - -	Use silicone caulking	-
20	8062	Bolt M10 x 14mm	4
21	8063	Cover	1
22	8064	Oil level plug	1
23	8065	Vent plug	1

GEAR BOX # 9307 (T279)

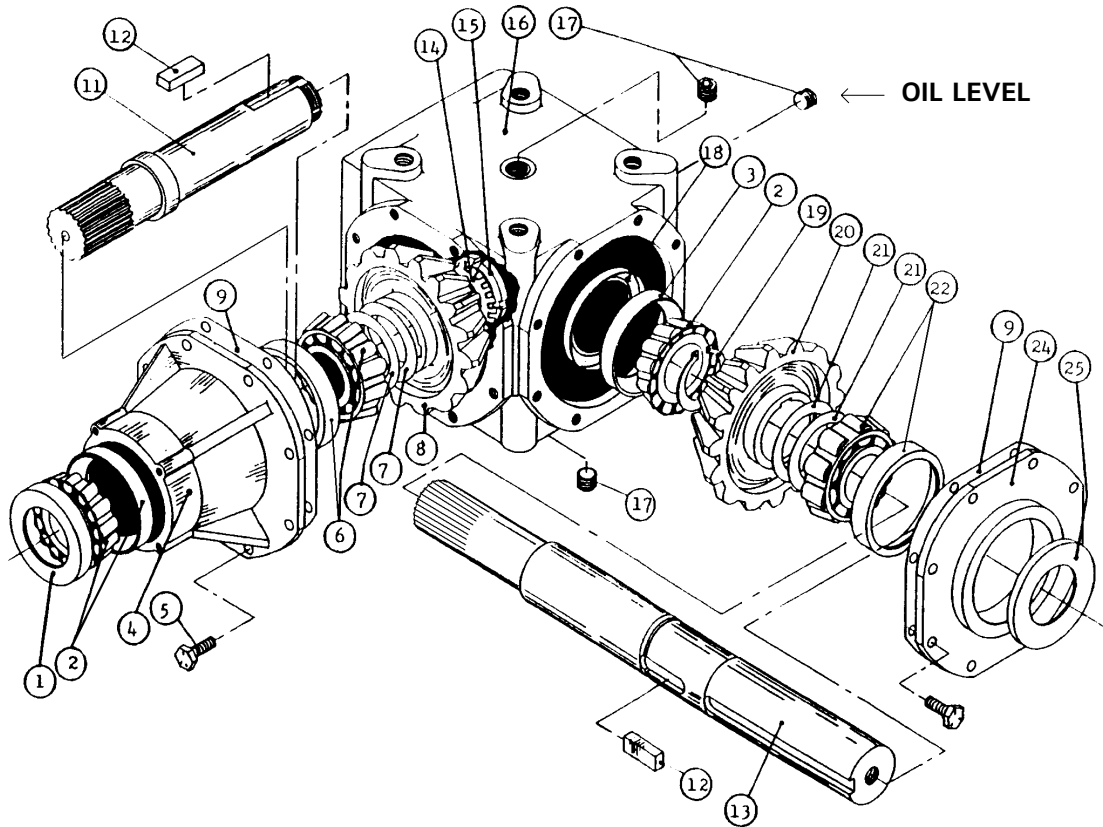

REF.	PART #	DESCRIPTION	QTY
1	6314	Oil seal 52 x 85 x 10	1
2	30209-A	Bearing: cone & cup	2
4	6318	Extension	1
5	6319	Bolt M10 x 22	16
6	32209-A	Bearing: cone & cup	1
7	6321	Shim	2
8	6322	Gear Z21	1
9	- - -	Use silicone caulking	-
11	6325	Side shaft Z20 (1 3/4" - 20 splines)	1
12	6326	Key B14 x 9 x 40	2
13	9345	Impeller shaft (2" & 1 3/4" - 20 splines)	1
14	6328	Spring washer	1
15	6329	Lock nut M40 x 1.5 H9	1
16	6330	Casing	1
17	6331	Plug 3/8" gas	3
18	6332	Dust excluder 45 x 72 x 8	1
19	6333	External circlip 50 UNI7435	1
20	6334	Gear Z21	1
21	6335	Shim	2
22	30210-A	Bearing: cone & cup	1
24	6338	Cover	1
25	6339	Oil seal 50 x 72 x 8	1

REDUCTION GEAR BOX # 8348

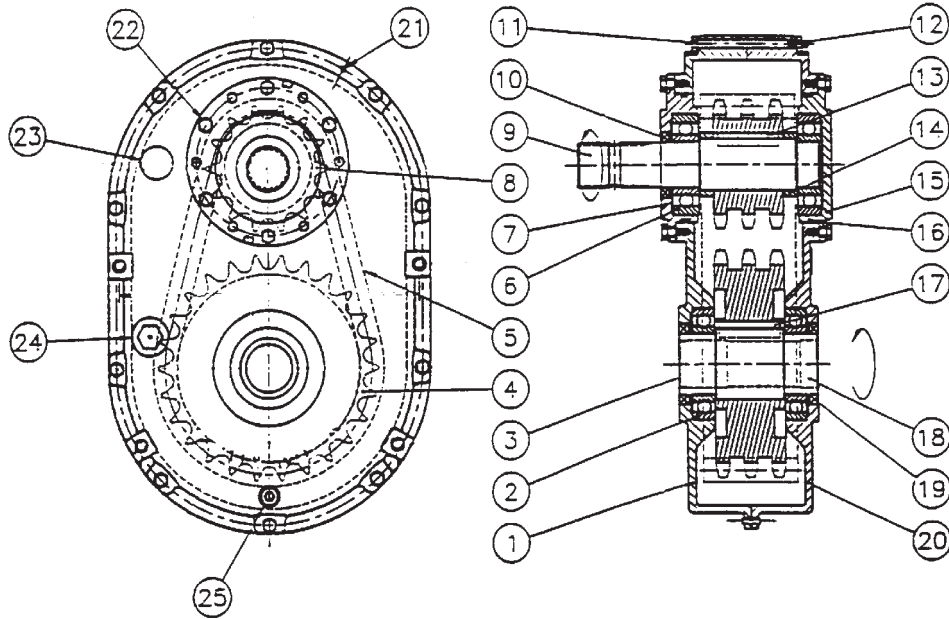

REF.	PART #	DESCRIPTION	QTY
1	9546	Casing with plug	1
2	6212-RS	Bearing 6212	2
3	9547	Seal cover (47 x 7)	1
4	9548	Sprocket 80-3A26	1
5	9549	Chain 80-3 x 36" lg	1
6	6309-RS	Bearing 6309	2
7	9550	Input cover with hole	1
8	9551	Sprocket 80-3A14	1
9	8349	Input shaft 1 3/8"-6 splines	1
10	9553	Oil seal (45x65x8) TC double lips	1
11	300-34490	Bolt 5/16" NC x 4 1/2" lg	10
12	336-34000	Nut 5/16" NC	10
13	9554	Square key 1/2" x 2 1/2"	1
14	9555	Spacer (2 - 2 3/8 - 0.568)	2
15	9556	Input cover w/o hole	1
16	9557	O-ring AS-248	2
17	9558	Square key 5/8" x 2 1/2"	1
18	8350	Output shaft 1 3/8"-6 splines	1
19	9560	Oil seal (60 x80x10) TC double lips	2
20	9561	Casing w/o plug	1
21	9562	Slotted spring pin 3/16" x 3/4"	2
22	300-30220	Bolt 3/16" NC x 3/4" lg	12
23	9563	Air vent 1/2" NPT	1
24	9564	Sight glass 3/4" NPT (oil level)	1
25	9565	Drain plug 1/2" NPT	1

REDUCTION GEAR BOX # 9575

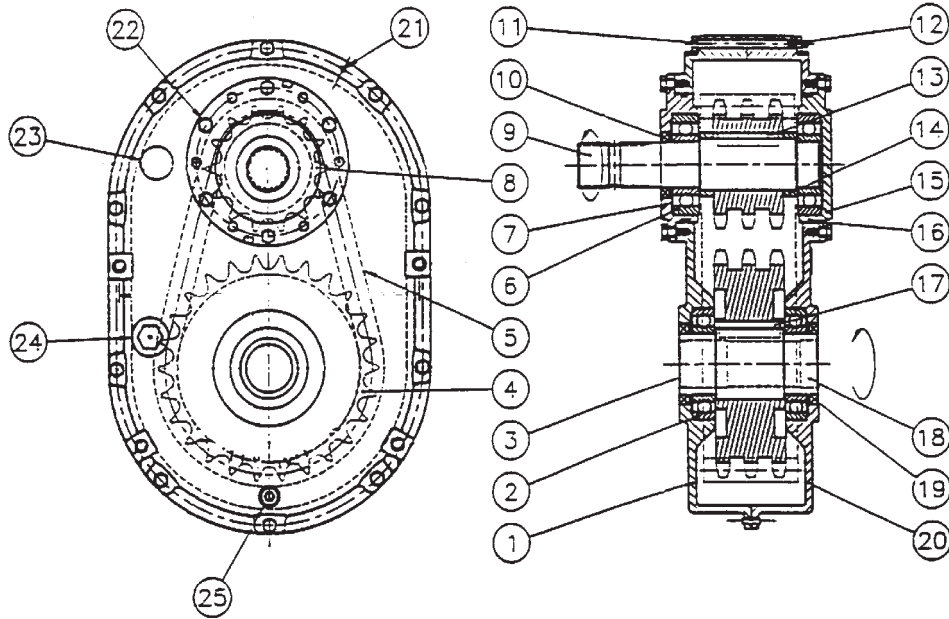

REF.	PART #	DESCRIPTION	QTY
1	9546	Casing with plug	1
2	6212-2RS	Bearing 6212	2
3	9547	Seal cover (47 x 7)	1
4	9548	Sprocket 80-3A26	1
5	9549	Chain 80-3 x 36" lg	1
6	6309-2RS	Bearing 6309	2
7	9550	Input cover with hole	1
8	9551	Sprocket 80-3A14	1
9	9552	Input shaft 1 3/4"-20 splines	1
10	9553	Oil seal (45x65x8) TC double lips	1
11	300-34490	Bolt 5/16" NC x 4 1/2" lg	10
12	336-34000	Nut 5/16" NC	10
13	9554	Square key 1/2" x 2 1/2"	1
14	9555	Spacer (2 - 2 3/8 - 0.568)	2
15	9556	Input cover w/o hole	1
16	9557	O-ring AS-248	2
17	9558	Square key 5/8" x 2 1/2"	1
18	9559	Output shaft 1 3/4"-20 splines	1
19	9560	Oil seal (60 x80x10) TC double lips	2
20	9561	Casing w/o plug	1
21	9562	Slotted spring pin 3/16" x 3/4"	2
22	300-30220	Bolt 3/16" NC x 3/4" lg	12
23	9563	Air vent 1/2" NPT	1
24	9564	Oil level sight glass 3/4" NPT	1
25	9565	Drain plug 1/2" NPT	1

CYLINDER 25TR08

15050

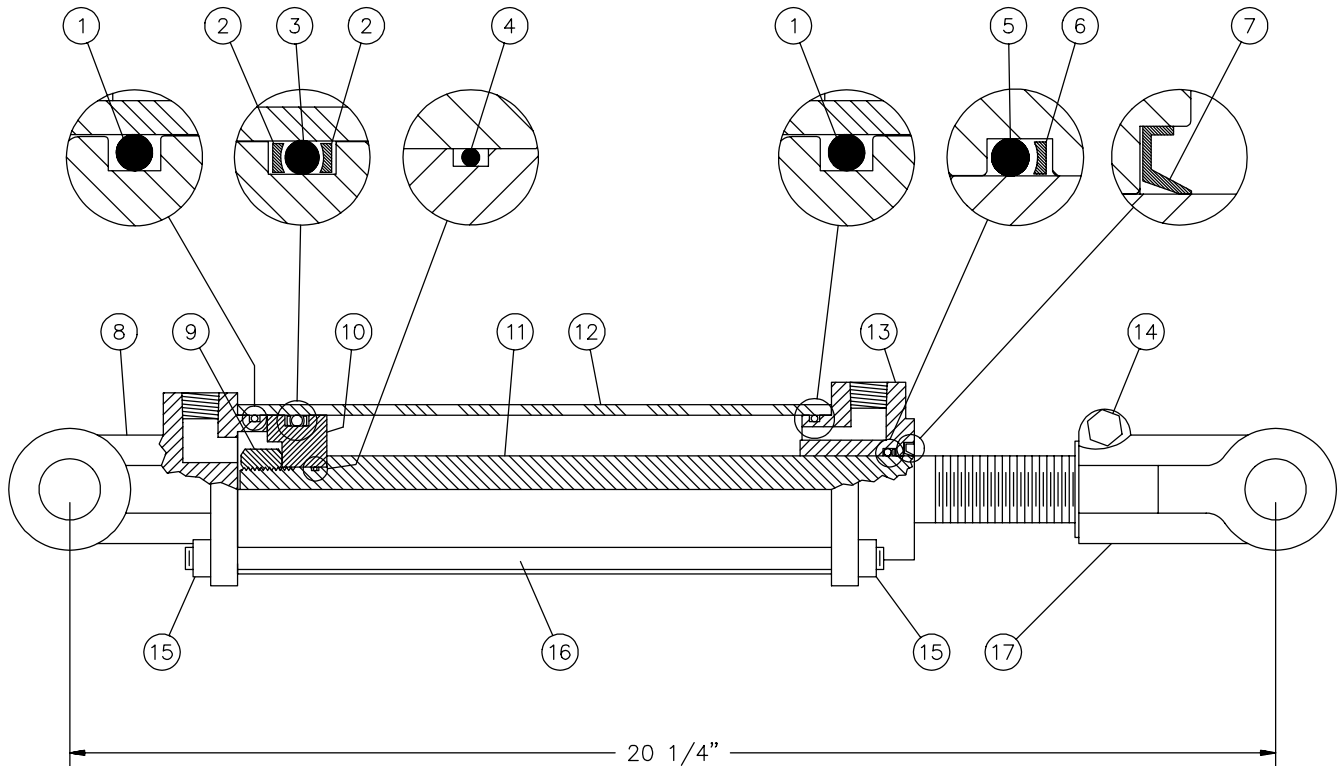

REF.	PART #	DESCRIPTION	QTY
1	See #RK25TR	O-ring 1/8" x 2 1/4" x 2 1/2"	2
2	See #RK25TR	Back-up 2 1/2" o.d. x 3/16 ø	2
3	See #RK25TR	O-ring 3/16" x 2 1/8" x 2 1/2"	1
4	See #RK25TR	O-ring 1/16" x 5/8" x 3/4"	1
5	See #RK25TR	O-ring 1/8" x 1 1/8" x 1 3/8"	1
6	See #RK25TR	Back-up 1 3/8" o.d. x 1/8" ø	1
7	See #RK25TR	Wiper 1 1/8" i.d. x 1 5/8" o.d.	1
8	492401	Yoke (for 2 1/2" tube)	1
9	338-46000	Nut 3/4" NF	1
10	4924-31	Piston 2 1/2" ø	1
11	492028	Piston rod 1 1/8"	1
12	491668	Cylinder body 2 1/2" ø	1
13	492421	Head (for 2 1/2" tube)	1
14	300-36355	Bolt 3/8" NC x 2 1/4" + nut	1
15	336-36000	Nut 3/8" NC	8
16	Std.	Threaded rod 3/8" NC x 12" lg	4
17	458599	Yoke (for 1 1/8" rod)	1
NI*	8183	Pin 1" ø + cotter pin	2
NI*	RK25TR	Repair kit for cylinder 2 1/2" (includes # 1, 2, 3, 4, 5, 6, & 7)	1

*NI = NOT ILLUSTRATED

CYLINDER 25J11.5

170-03991

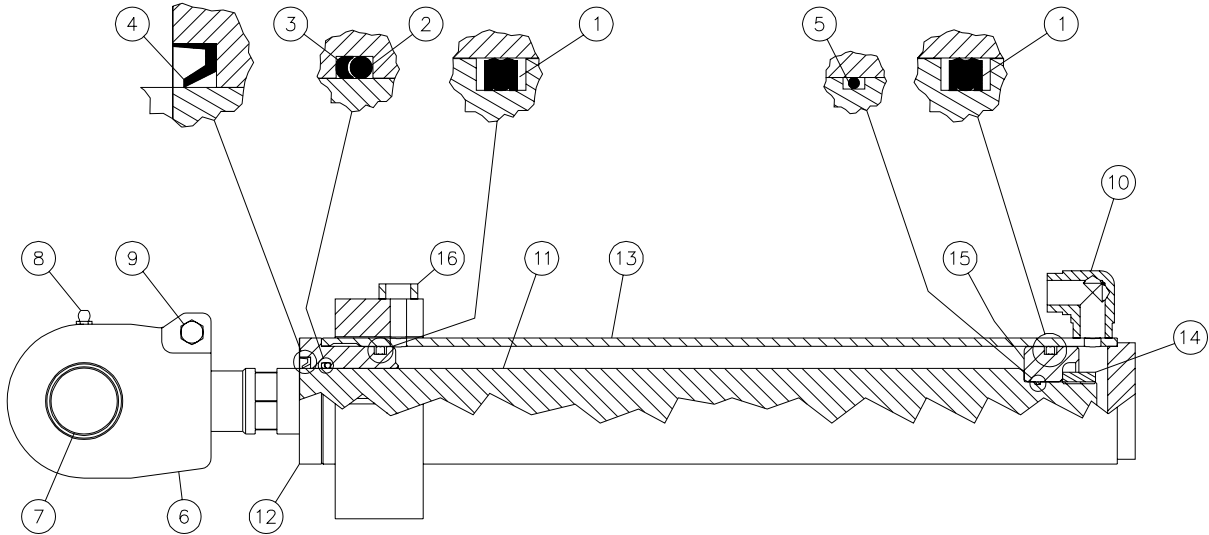

REF.	PART #	DESCRIPTION	QTY	
			25J11.5G	25J11.5D
1	PSP-330	O-ring «heavy duty» 3/16" x 2 1/8" x 2 1/2"	2	2
2	OR-222	O-ring 1/8" x 1 1/2" x 1 3/4"	1	1
3	BU-222	Back-up 1/8" x 1 1/2" x 1 3/4"	1	1
4	AR-2269FO	Wiper 1/8" x 1 1/2" x 2"	1	1
5	OR-018	O-ring 1/16" x 3/4" x 7/8"	1	1
6	130-34901	Piston rod end 1 3/8"-12	1	1
7	160-12011	Aluminium-bronze bushing 1 1/2" i.d. x 1 3/4" o.d. x 1 3/4" lg	1	1
8	Std.	Grease fitting 1/4"-28 straight	1	1
9	300-34325	Bolt 5/16" NC x 1 3/4" lg. + nylon locknut	1	1
10	3509-06-06	Elbow 90 deg.	1	1
11	150-07821	Piston rod 1 1/2" x 18 3/16"	1	1
12	150-05421	Head 2 1/2"	1	1
13	110-28591	Cylinder body 2 1/2" dia. x 18 1/2" right side	-	1
13	110-28592	Cylinder body 2 1/2" dia. x 18 1/2" left side	1	-
14	339-48220	Nut 7/8" NF	1	1
15	150-05431	Piston 2 1/2" dia.	1	1
16	Std.	Half-ring 3/8"	1	1
NI*	8379	Repair kit for cylinder (includes #1,2,3,4 and 5)	1	1

*NI = Not illustrated

CYLINDER 25J15.5

170-03681

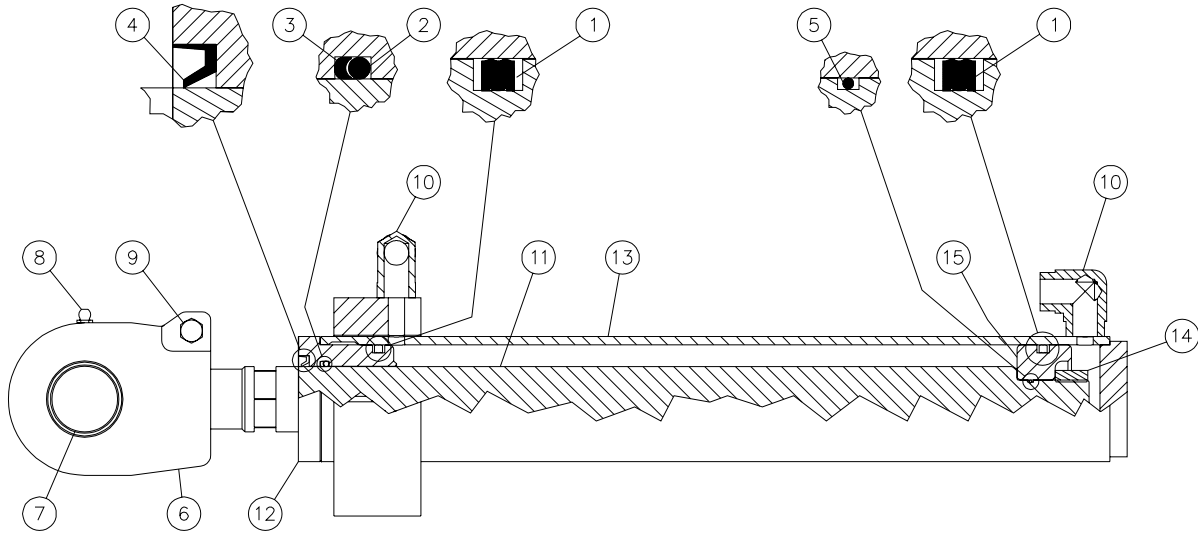

REF.	PART #	DESCRIPTION	QTY	
			25J15.5G	25J15.5D
1	PSP-330	O-ring «heavy duty» 3/16" x 2 1/8" x 2 1/2"	2	2
2	OR-222	O-ring 1/8" x 1 1/2" x 1 3/4"	1	1
3	BU-222	Back-up 1/8" x 1 1/2" x 1 3/4"	1	1
4	AR-2269FO	Wiper 1/8" x 1 1/2" x 2"	1	1
5	OR-018	O-ring 1/16" x 3/4" x 7/8"	1	1
6	130-34901	Piston rod end 1 3/8"-12	1	1
7	160-12011	Aluminium-bronze bushing 1 1/2" i.d. x 1 3/4" o.d. x 1 3/4" lg	1	1
8	Std.	Grease fitting 1/4"-28 straight	1	1
9	300-34325	Bolt 5/16" NC x 1 3/4" lg. + nylon locknut	1	1
10	3509-06-06	Elbow 90 deg. (welded)	2	2
11	150-05991	Piston rod 1 1/2" x 22 3/16"	1	1
12	150-05421	Head 2 1/2"	1	1
13	110-25191	Cylinder body 2 1/2" dia. x 19 1/2" left side	1	-
13	110-25192	Cylinder body 2 1/2" dia. x 19 1/2" right side	-	1
14	339-48220	Nut 7/8" NF	1	1
15	150-05431	Piston 2 1/2" dia.	1	1
NI*	8379	Repair kit for cylinder (includes #1,2,3,4 and 5)	1	1

10

*NI = Not illustrated

HYDRAULIC MOTOR # MLH-250 & MLH-315

CUSHION VALVE H110

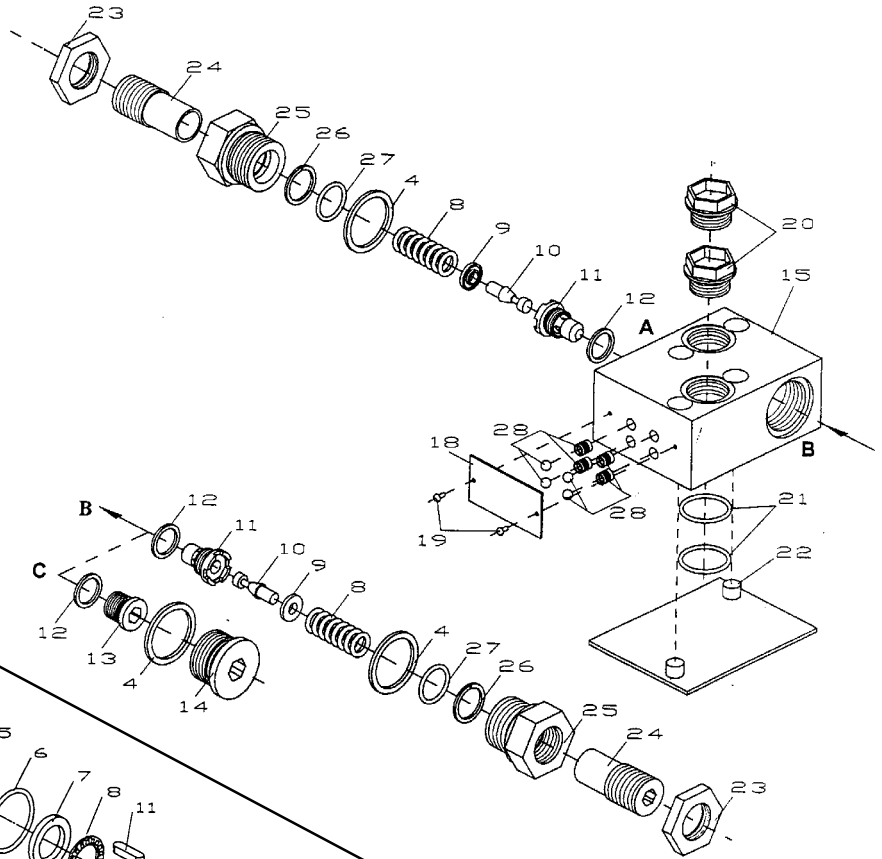

MOTOR

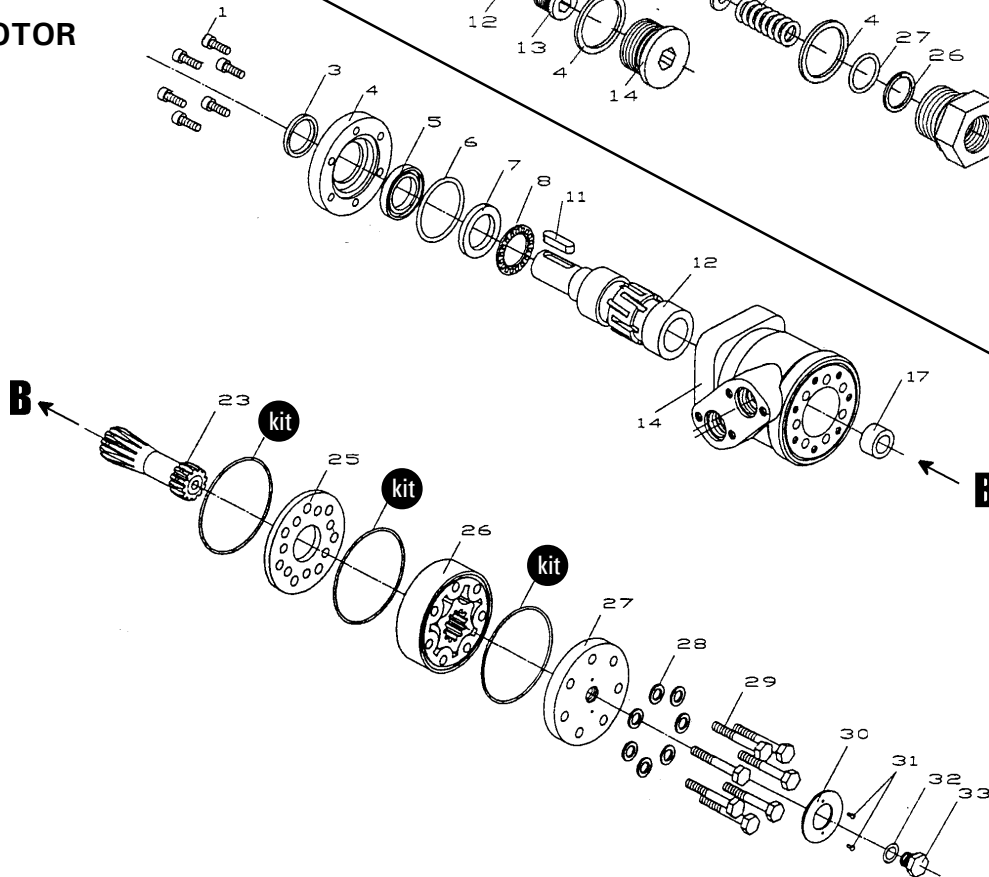







REF.	PART #	DESCRIPTION	QTY
kit	8368	Set of seals.....	1
11	8369	Key for "Orbit" motor.....	1

10





TORQUE CHART

11

TORQUE SPECIFICATION TABLE

Thread UNC and UNF		Grade 2 				Grade 5   				Grade 8*   			
Bolt size		Torque				Torque				Torque			
Inches	mm	Pound feet min.	max.	Newton meters min.	max.	Pound feet min.	max.	Newton meters min.	max.	Pound feet min.	max.	Newton meters min.	max.
1/4	6.35	5	6	6.8	8.13	9	11	12.2	14.9	12	15	16.3	30.3
5/16	7.94	10	12	13.6	16.3	17	20.5	23.1	27.8	24	29	32.5	39.3
3/8	9.53	20	23	27.1	31.2	35	42	47.5	57.0	45	54	61.0	73.2
7/16	11.11	30	35	40.7	47.4	54	64	73.2	86.8	70	84	94.9	113.9
1/2	12.70	45	52	61.0	70.5	80	96	108.5	130.2	110	132	149.2	179.0
9/16	14.29	65	75	88.1	101.6	110	132	149.2	179.0	160	192	217.0	260.4
5/8	15.88	95	105	128.7	142.3	150	180	203.4	244.1	220	264	298.3	358.0
3/4	19.05	150	185	203.3	250.7	270	324	366.1	439.3	380	456	515.3	618.3
7/8	22.23	160	200	216.8	271.0	400	480	542.4	650.9	600	720	813.6	976.3
1	25.40	250	300	338.8	406.5	580	696	786.5	943.8	900	1080	1220.4	1464.5
1 1/8	25.58	-	-	-	-	800	880	1084.8	1193.3	1280	1440	1735.7	1952.6
1 1/4	31.75	-	-	-	-	1120	1240	1518.7	1681.4	1820	2000	2467.9	2712.0
1 3/8	34.93	-	-	-	-	1460	1680	1979.8	2278.1	2380	2720	3227.3	3688.3
1 1/2	38.10	-	-	-	-	1940	2200	2630.6	2983.2	3160	3560	4285.0	4827.4

* Thick nuts must be used with grade 8 bolts.

Size of screw	Thread	Pitch (mm)	Grade 4T  				Grade 7T 				Grade 8T  			
			Torque				Torque				Torque			
			Pound feet min.	max.	Newton meters min.	max.	Pound feet min.	max.	Newton meters min.	max.	Pound feet min.	max.	Newton meters min.	max.
M6	UNC	1.00	3.6	5.8	4.9	7.9	5.8	9.4	7.9	12.7	7.2	10	9.8	13.6
M8	UNC	1.25	7.2	14	9.8	19	17	22	23	29.8	20	26	27.1	35.2
M10	UNC	1.5	20	25	27.1	33.9	34	40	46.1	54.2	38	46	51.5	62.3
M12	UNC	1.75	28	34	37.9	46.1	51	59	69.1	79.9	57	66	77.2	89.4
M14	UNC	2.0	49	56	66.4	75.9	81	93	109.8	126	96	109	130.1	147.7
M16	UNC	2.0	67	77	90.8	104.3	116	130	157.2	176.2	129	145	174.8	196.5
M18	UNC	2.0	88	100	119.2	136	150	168	203.3	227.6	175	194	237.1	262.9
M20	UNC	2.5	108	130	146.3	176.2	186	205	252	277.8	213	249	288.6	337.4
M8	UNF	1.0	12	17	16.3	23	19	27	25.7	36.6	22	31	29.8	42
M10	UNF	1.25	20	29	27.1	39.3	35	47	47.4	63.7	40	52	54.2	70.5
M12	UNF	1.25	31	41	42	55.6	56	68	75.9	92.1	62	75	84	101.6
M14	UNF	1.5	52	64	70.5	86.7	90	106	122	143.6	107	124	145	168
M16	UNF	1.5	69	83	93.5	112.5	120	138	162.6	187	140	158	189.7	214.1
M18	UNF	1.5	100	117	136	158.5	177	199	239.8	269.6	202	231	273.7	313
M20	UNF	1.5	132	150	178.9	203.3	206	242	279.1	327.9	246	289	333.3	391.6

Use the above torques when special torque is not given.

NOTE: These values apply to fasteners as received from supplier, dry, or when lubricated with normal engine oil. They do not apply if extreme pressure lubricants are used.

WARRANTY

PRONOVOST warrants this product to the initial purchaser for the period of one year from the date of purchase against defects in materials and workmanship.

We will replace or repair defective parts free of charge if they are returned to our plant in St-Tite, Quebec, Canada.

Transportation charges are the responsibility of the customer. This warranty is not transferable.

Hydraulic cylinders and motors are covered by the manufacturer of these items.

All PRONOVOST spare parts purchased are covered by a three (3) month warranty.

This warranty becomes void and nul if the equipment is modified, breaks down as the result of an accident, is not operated according to manufacturer's recommendations, damaged by negligence or if maintenance has not been carried out as specified.

Our obligation is limited to the replacement or repair of the defective part. PRONOVOST accepts no responsibility for direct or indirect consequential damages of any kind.

Ce manuel est aussi disponible en français.
Veuillez téléphoner.



INNOVATION - EXCELLENCE

LES MACHINERIES PRONOVOST INC.

260, route 159,

Saint-Tite, Quebec, Canada, G0X 3H0

Tel.: (418) 365-7551, Fax: (418) 365-7954

www.pronovost.qc.ca