



## OPERATOR'S / PARTS MANUAL

C2306R1

11/2009



LYNX 52 LYNX 62 LYNX 70

### GENERAL SAFETY

#### WHEN YOU SEE THIS SYMBOL



**ATTENTION!  
BE ALERT**

#### YOUR SAFETY IS INVOLVED

This symbol «**SAFETY ALERT**» is used in this manual and on the safety decals on the Snowblower. It warns you of the possibility of danger. Carefully read, understand and follow all safety recommendations before operating the Snowblower.

- 1) Careful operation is the best assurance against accidents. Carefully read this manual and follow all recommendations before operating your Snowblower. It is the owner's responsibility to make sure that anyone who will operate the Snowblower will read this manual before operating the equipment.
- 2) Familiarize yourself with all controls and always be ready to stop the Snowblower quickly in case of emergency.
- 3) Never let a child operate the Snowblower.
- 4) Do not modify the Snowblower. Any non authorized modification may affect the efficiency and/or safety of the equipment.
- 5) Never operate the Snowblower with defective parts or if damaged in any way. Have it repaired before operating.
- 6) Make sure all fasteners are in place and properly secured or tightened.
- 7) Avoid wearing loose fitting clothing when working with the Snowblower. These could get entangled in moving parts of the equipment and cause accidents.
- 8) Prolonged exposure to noise may hamper hearing. Protect yourself by wearing adequate protection devices.
- 9) Hydraulic fluids under pressure can damage your skin. Do not use your hands to locate a leak.
- 10) Before the beginning of the snow season, inspect all areas where the Snowblower will be used and remove any object which may cause an accident and/or damage the equipment.
- 11) Never operate your Snowblower in poor visibility or without proper lighting conditions.

### SAFETY IN OPERATION

- 1) Be sure there are no obstructions around the equipment and that no one stands near the equipment when in operation.
- 2) Do not operate an engine in a confined or non ventilated area.
- 3) Do not perform any adjustments, cleaning, maintenance or repairs with the engine running. The engine must be stopped and the P.T.O. disengaged. Preferably remove the key from the ignition.
- 4) Wear adequate clothing when working in cold or windy conditions.
- 5) Before operating, make sure the P.T.O. is properly installed and secured.
- 6) Before starting-up the Snowblower, make sure the auger and drum areas are free of ice.
- 7) Put P.T.O. control in neutral position before starting engine.
- 8) Keep hands, feet and clothing away from moving parts of the Snowblower. Stay away from the discharge chute.
- 9) Before unplugging the chute, always disengage the P.T.O., stop the engine and relieve all hydraulic pressures.
- 10) Do not operate in excessive inclined conditions. Be careful when turning in slopes.
- 11) Never operate your Snowblower with missing guards or without protective devices in place.
- 12) Do not operate your Snowblower near buildings, windows or other vehicles without prior and proper adjustment of the chute deflector.
- 13) Never aim discharge chute towards people or animals. This may cause serious injuries.
- 14) Always reduce operating speed in slippery conditions.
- 15) Be careful when backing-up, make sure you have good visibility.
- 16) Always be on the lookout for objects which may enter the Snowblower.
- 17) If undue vibrations are felt, disengage the P.T.O., stop the motor and look for the cause of the vibration. Vibration is usually the indication of a problem.
- 18) At the end of the operation, disengage the P.T.O., lower the Snowblower, put transmission in neutral, apply parking brake, stop engine and remove the key from the ignition.

## SAFETY WITH MAINTENANCE

- 1) Perform the Snowblower maintenance according to recommendations contained in this manual.
- 2) Stop engine and relieve all hydraulic pressures before doing inspection, maintenance or repairs.
- 3) Never perform any work under the Snowblower while it is supported only by the tractor's hydraulic system. It must be completely supported by wooden blocks or other safe means.

## SAFETY IN TRANSPORT

- 1) On public roads, use proper safety lights and check local regulations.
- 2) Be alert while driving on the road. Never carry passengers.
- 3) Always disengage P.T.O. while moving from one area of work to another.

- 4) The recommended road speed should be such as to maintain full control over steering and braking.
- 5) Be careful while backing up, make sure you have good visibility.

## SAFETY IN STORAGE

- 1) Provide adequate supports to prevent any accidental overturning of the Snowblower.
- 2) Do not let children play in the area where the Snowblower is stored.

## SAFETY DECALS

The safety decals are affixed wherever special safety precautions are indicated. Locate them on the machine and read them carefully. If a decal is damaged, lost or illegible, install a new one. Each decal is shown and identified with a part number.

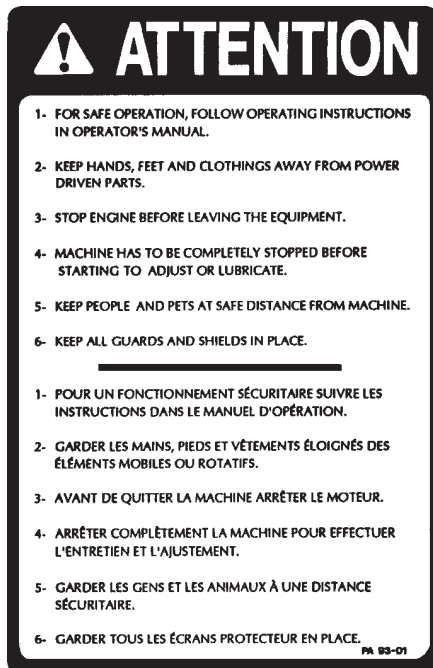

Part no.: A102



Part no.: A109



Part no.: A108

## MAINTENANCE

- 1) Wipe off all grease fittings with a clean cloth before adding grease in order to avoid injecting dirt and sand.
- 2) Repair or replace damaged grease fittings.
- 3) Lubricate all grease fittings every 8 hours of operation.
- 4) Oil drive chain every 8 hours of operation.
- 5) Lubricate P.T.O. shaft as indicated below:

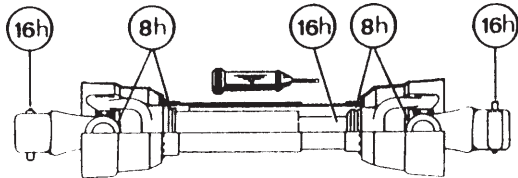

Pull out the P.T.O. and lubricate between the two tubes with low temperature grease. Drive line tubes must slide easily even in cold weather. Clean off old hardened grease and apply fresh grease as needed.

- 6) Check oil level in gear box once a month. If necessary add oil.
- 7) Check tension of drive chain every 24 hours of operation and adjust if necessary.
- 8) Check for tightness of bearing collars every 48 hours of operation.
- 9) Change gearbox oil once a year. Use gear box oil S.A.E. W90 rated API, class GL-5.

- 10) Check all nuts and bolts once a year.
- 11) For the auger drive shaft, always use grade 2 shear bolts.
- 12) For the PTO shaft, always use a grade 8.8 shear bolt.
- 13) UHMW slides do not require lubrication except at the end of the season in order to prevent corrosion of steel components that are in contact with the UHMW material.

## STORAGE

- 1) Store the Snowblower in a cool, dry place.
- 2) Support the Snowblower with wooden blocks.
- 3) Keep all piston rods in the retracted position. This will assure better protection against the elements.
- 4) Clean your Snowblower.
- 5) Thoroughly inspect all parts of the Snowblower. Replace or repair worn or defective parts.
- 6) Touch-up or repaint if necessary.
- 7) Lubricate all points before storage.

## SPECIFICATIONS

Design and specifications subject to change without notice

MODEL	LYNX 52	LYNX 62	LYNX 70
Horse power recommended	16 - 25	18 - 25	18 - 25
Working width	52"	62"	70"
Cutting height	25"	25"	25"
Impeller diameter	21"	21"	21"
Depth of drum	6"	6"	6"
Impeller blades	4	4	4
Size of impeller shaft	1"	1"	1"
Impeller RPM	540	540	540
Main auger diameter	13½"	13½"	13½"
Drive chain	50	50	50
Hitch category	1	1	1
P" T" O" shaft	No. 2	No. 2	No. 2
Chute rotation on UHMW	Standard	Standard	Standard
Weight (lbs)	321	338	351

# SNOWBLOWERS LYNX 52 LYNX 62 LYNX 70

170-05075

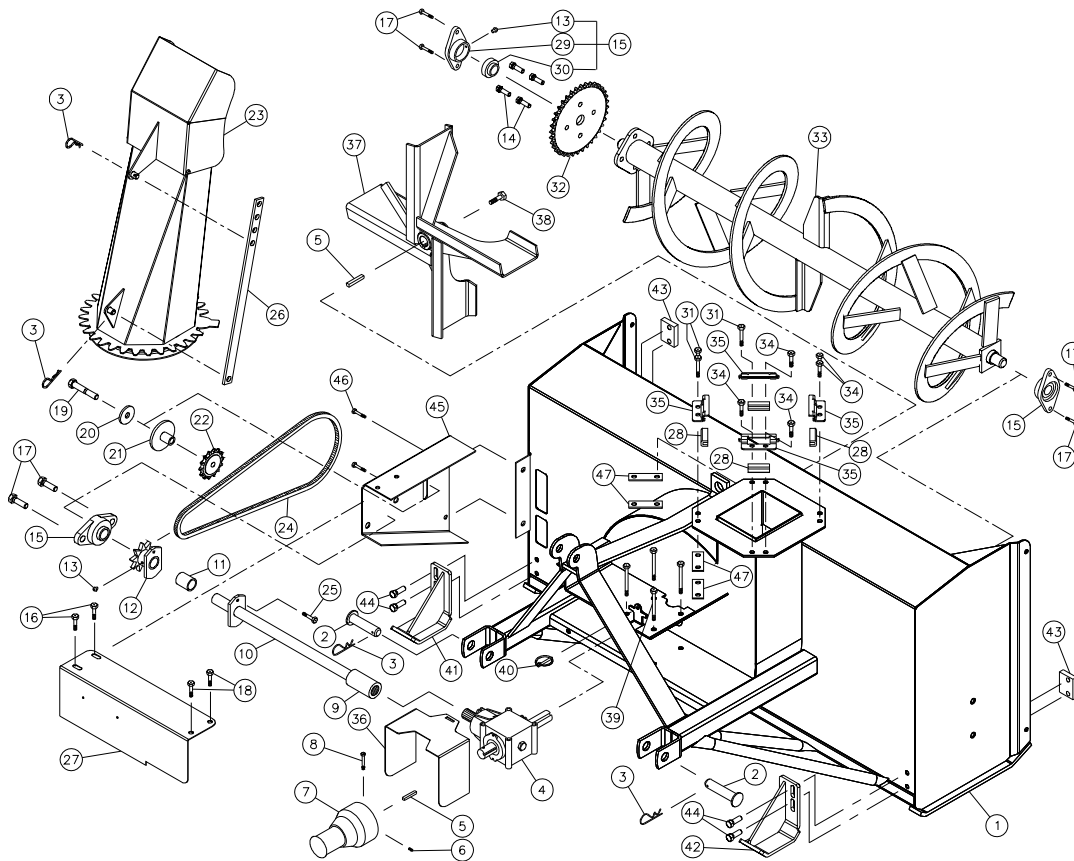

# SNOWBLOWERS LYNX 52 LYNX 62 LYNX 70 (cont'd)

REF.	PART #	DESCRIPTION	52	62	70	QTE
1	120-07122	Frame 52"	1	-	-	-
1	120-07172	Frame 62"	-	1	-	-
1	120-07142	Frame 70"	-	-	1	-
2	110-03331	Pin category 1	2	2	2	2
3	Std.	Hitch pin clip 5/32"	4	4	4	4
4	6550	Gear box 1" o x 1.15 splines	1	1	1	1
5	140-03871	Key 1/4" x 1/4" x 1.56" lg	2	2	2	2
6	323-32160	Hexagonal socket set screw 1/4"-20 x 3/8" lg	1	1	1	1
7	6545	P.T.O. shaft #2 1" o x 1.3/8" 6	1	1	1	1
8	300-32370	Bolt 1/4" NC x 2 1/2" lg + nylon locknut	1	1	1	1
9	6565	Spined adaptor 1"-15	1	1	1	1
10	110-40411	Auger drive shaft 20 1/4" lg overall (including #9)	-	-	-	-
10	110-40641	Auger drive shaft 25 1/4" lg overall (including #9)	-	-	-	-
10	110-40481	Auger drive shaft 29 1/4" lg overall (including #9)	-	-	-	-
11	6566	Bushing 1" i.d. x 1 1/8" o.d. x 1 1/2" lg	1	1	1	1
12	6667	Sprocket # 50 + sheaplate (including #11 and #13)	1	1	1	1
13	Std.	Grease fitting 1/4"-28 straight	4	4	4	4
14	300-36280	Bolt 3/8" NC x 1 1/4" lg + two-way locknut	4	4	4	4
15	UCFLD205-16	Bearing 1" o + flange	3	3	3	3
16	300-36250	Bolt 3/8" NC x 1" lg + nylon locknut & flat washer	2	2	2	2
17	300-40250	Bolt 1/2" NC x 1" lg + nylon locknut (thin)	6	6	6	6
18	300-36250	Bolt 3/8" NC x 1" lg + nylon locknut	2	2	2	2
19	300-40400	Bolt 1/2" NC x 3" lg + nylon locknut	1	1	1	1
20	378-40340	Flat washer 1/2" i.d. x 2" o.d.	1	1	1	1
21	110-07732	Idler	1	1	1	1
22	6604	Idler sprocket #50	1	1	1	1
23	120-07131	Chute	1	1	1	1
24	190-11261	Chain #50 x 50" lg	1	1	1	1
24	26A50	Connecting link #50	1	1	1	1
24	59-50	Offset link #50	1	1	1	1
25	312-32250	Shear bolt 1/4" NC x 1" lg grade 2 + nylon locknut	1	1	1	1
26	140-23811	Chute adjusting bar	1	1	1	1
27	130-72451	Auger drive shaft guard	1	-	-	-
27	130-73011	Auger drive shaft guard	-	1	-	-
27	130-72691	Auger drive shaft guard	-	-	1	-
28	190-11251	U-shaped UHMW x 2" lg	4	4	4	4
29	FLD205	Flange	3	3	3	3
30	UC205-16	Bearing 1" o	3	3	3	3
31	300-36280	Bolt 3/8" NC x 1 1/4" lg + nylon locknut & flat washer	1	1	1	1
32	6288	Sprocket 50A36 T 1" o	1	1	1	1
33	110-40451	Auger LYNX-52	-	-	-	-
33	110-40651	Auger LYNX-62	-	-	-	-
33	110-40491	Auger LYNX-70	-	-	-	-
34	300-36250	Bolt 3/8" NC x 1" lg + nylon locknut	5	5	5	5
35	130-72661	Chute retaining bracket	4	4	4	4
36	130-72481	P.T.O. shroud	1	1	1	1
37	110-40461	Impeller 6" x 21" o 4 blades T 1" o	1	1	1	1
38	329-34280	Bolt 5/16" x 1 1/4" lg (ass. with locitte 242) + lock washer	1	1	1	1
39	300-36520	Bolt 3/8" NC x 5" lg + nylon locknut	4	4	4	4
40	Std.	Lynch pin 3/16" x 1 1/4"	1	1	1	1
41	110-40791	Skid shoe (left side) (1)	opt.	opt.	opt.	opt.
42	110-40801	Skid shoe (right side) (1)	opt.	opt.	opt.	opt.
43	140-23981	Back plate (2)	opt.	opt.	opt.	opt.
44	300-36280	Bolt 7/16" NC x 1 1/4" lg + flat washer + spring washer (4)	1	1	1	1
45	130-72512	Chain guard	1	1	1	1
46	300-36250	Bolt 3/8" x 1" lg + nylon locknut	2	2	2	2
47	140-24311	Spacer (for chute rotation MD-4872 only)	4	4	4	4

# MANUAL CHUTE KIT MD-4872

170-04301L

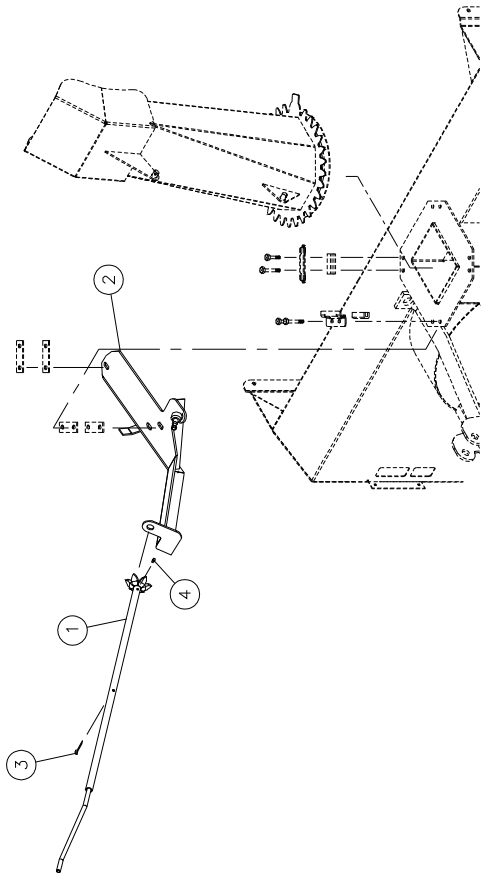

REF.	PART #	DESCRIPTION	QTY
1	110-27702	Crank	1
2	110-27712	Base	1
3	Std.	Roll pin 1/4" x 1 3/4" lg	1
4	Std.	Grease fitting 1/4"-28 straight	1

# HYDRAULIC CHUTE KIT HRD-5270

170-05191

## INSTALLATION OF THE CHUTE ROTATION MECHANISM

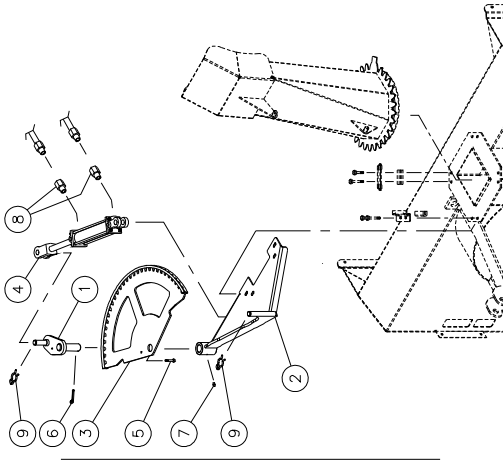

- 1- Put the two first tooth one in the other (see **A**)
- 2- Check and adjust the hydraulic cylinder as indicated before installing:

Model	Min	Max
HRD-5470	14 1/4"	18 1/4"

REF.	PART #	DESCRIPTION	QTY
1	110-27653	Pivot	1
2	110-27683	Base	1
3	110-27613	Arc	1
4	25TR04	Cylinder 2 1/2" x 4" stroke	1
5	Std.	Bolt 1/4" NC x 1 1/2" lg grade 5 + nylon locknut	1
6	Std.	Cotter pin 1/4" x 2"	1
7	Std.	Grease fitting 1/4"-28 straight	1
8RS-1/16x08 NPT		Kit of two unidirectional restrictors 110-39711	opt. 1
9	Std.	Hairpin cotter 7/8"	2

# P.T.O. SHAFT #6545 (T20)

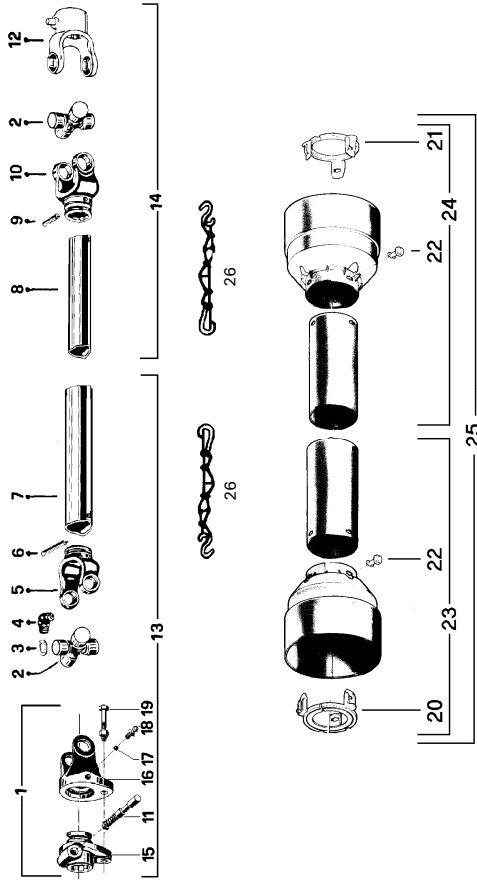

REF.	PART #	DESCRIPTION	QTY
1	6201	Quick disconnect yoke assembly	1
2	6208	U-joint + 4 retaining ring + 1 grease fitting	2
3	6203	Retaining ring	8
4	8110	Grease fitting	2
5	6430	Yoke for outer tube	1
6	6344	Pin spring	1
7	6431	Outer tube	1
8	6432	Inner tube	1
9	6433	Pin spring	1
10	6434	Yoke for inner tube	1
11	8068-E	Yoke stopper 1 3/8"	1
12	6215	Yoke with round hole 1"	1
13	6435	P.T.O. section, side with safety shear bolt, outer part, without protector	1
14	6546	P.T.O. section, side without safety shear bolt, inner part, without protector	1
15	6202	Adaptor	1
16	6204	Yoke and shearplate	1
17	6205	Ball	17
18	6206	Grease fitting	1
19	6207	Safety shear bolt M6 x 40mm	1
20	6218-E	Bearing ring for outer guard tube	1
21	6219-E	Bearing ring for inner guard tube	1
22	8109	Stopper	6
23	6220	Outer shield	1
24	6221	Inner shield	1
25	6222	Complete shield	1
26	8308	Safety chain	2

# GEAR BOX #6550

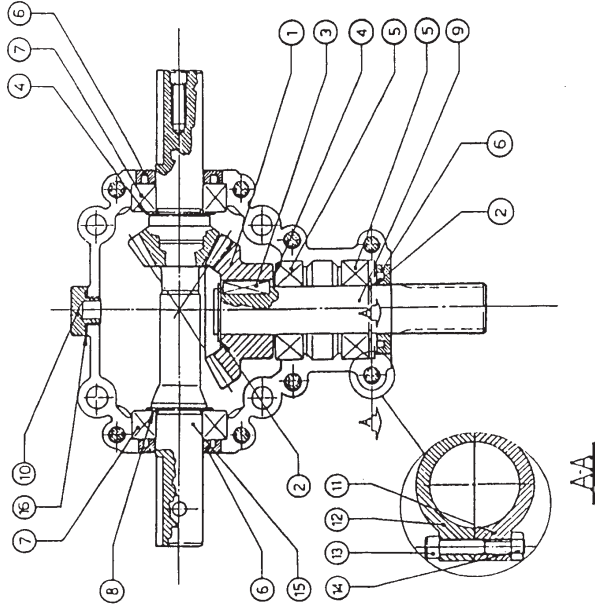

REF.	PART #	DESCRIPTION	QTY
1	6547	Gear Z24	1
2	6548	Outside circlip	2
3	6549	Parallel key 8 x 7 x 25	1
4	6562	Shim	2
5	6205-2RS	Bearing 6205	2
6	6552	Oil seal	3
7	6205-2RSx1"	Bearing	2
8	6554	Shim	1
9	6555	Side shaft 1" - 15 splines	1
10	6556	Plug 3/8" GAS	1
11	6557	Casing A	1
12	6558	Casing A	1
13	6559	Bolt M8 x 45 8.8	8
14	6428	Nex. nut M8 8	8
15	6560	Pinion shaft Z16 for impeller (1" & 1")	1
16	6425	O-ring OR-3062	1

# CYLINDER 25TR04

15050

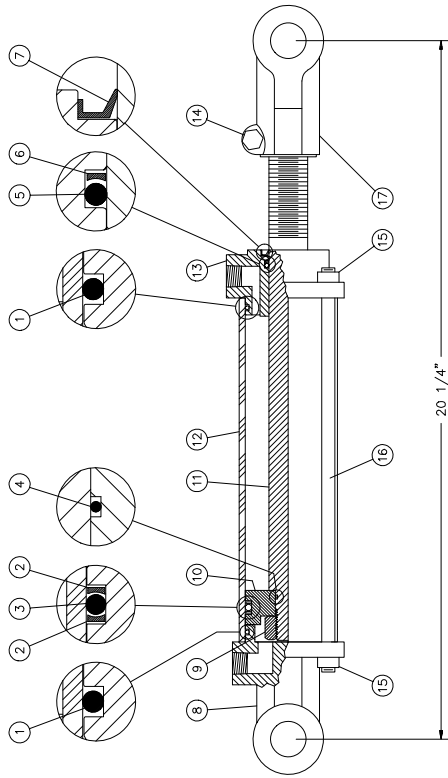

REF.	PART #	DESCRIPTION	QTY
1	See RK25TR	O-ring 1/8" x 2 1/4" x 2 1/2"	2
2	See RK25TR	Back-up 2 1/2" o.d. x 3/16" x 2 1/2"	2
3	See RK25TR	O-ring 3/16" x 2 1/8" x 2 1/2"	1
4	See RK25TR	O-ring 1/16" x 5/8" x 3/4"	1
5	See RK25TR	O-ring 1/8" x 1 1/8" x 1 3/8"	1
6	See RK25TR	Back-up 1 3/8" d.e. x 1/8" ø	1
7	See RK25TR	Wiper 1 1/8" d.i. x 1 5/8" d.e.	1
8	492401	Yoke (for 2 1/2" tube)	1
9	338-46000	Nut 3/4" NF	1
10	4924-31	Piston 2 1/2" ø	1
11	491980-04	Piston rod 1 1/8"	1
12	491668-04	Cylinder body 2 1/2" ø	1
13	492421	Head (for 2 1/2" tube)	1
14	300-36355	Bolt 3/8" NC x 2 1/4" lg + nut	1
15	336-36000	Nut 3/8" NC	8
16	Std.	Threaded rod 3/8" NC x 8" lg	4
17	458599	Yoke (for 1 1/8" rod)	1
NI*	8183	Pin 1" ø + cotter pin	2
NI*	RK25TR	Repair kit for cylinder 2 1/2" (includes # 1, 2, 3, 4, 5, 6, & 7)	1

\*NI = NOT ILLUSTRATED

# WARRANTY

PRONOVOST / HARDY warrants this product to the initial purchaser for the period of one year from the date of purchase against defects in materials and workmanship.

We will replace or repair defective parts free of charge if they are returned to our plant in Saint-Tite, Quebec, Canada.

Transportation charges are the responsibility of the customer. This warranty is not transferable.

Hydraulic cylinders are covered by the manufacturer of these items.

The PTO shafts are warranted by the manufacturer and cover **only** defects in material and workmanship, and is conditional to recommended use and installation only.

All PRONOVOST spare parts purchased are covered by a three (3) month warranty.

This warranty becomes void and nul if the equipment is modified, breaks down as the result of an accident, is not operated according to manufacturer's recommendations, damaged by negligence or if maintenance has not been carried out as specified.

Our obligation is limited to the replacement or repair of the defective part. PRONOVOST / HARDY accepts no responsibility for direct or indirect consequential damages of any kind.

Ce manuel est aussi disponible en français.  
Veuillez téléphoner.



**INNOVATION - EXCELLENCE**

**LES MACHINERIES PRONOVOST INC.**

260, route 159,

Saint-Tite, Quebec, Canada, G0X 3H0

Tel.: (418) 365-7551, Fax: (418) 365-7954

E-mail: [info@pronovost.qc.ca](mailto:info@pronovost.qc.ca)

Website: [www.pronovost.qc.ca](http://www.pronovost.qc.ca)