



**OPERATOR'S / PARTS  
MANUAL**



***Snowblowers***  
**Model**  
**PGS-1020TRC**



Copyright © Les Machineries Pronovost Inc., 2010

All rights reserved.  
Printed in Canada.

---



---

# **TABLE OF CONTENTS**

---

<b>Section</b>	<b>Item</b>	<b>Page</b>
<b>1</b>	<b>Introduction .....</b>	<b>5</b>
<b>2</b>	<b>Safety .....</b>	<b>6</b>
	General Safety .....	6
	Safety in Operation .....	6
	Safety with Maintenance .....	7
	Safety in Transport .....	7
	Safety in Storage .....	7
<b>3</b>	<b>Decals .....</b>	<b>8</b>
	Safety Decals .....	8
	Maintenance Decals .....	12
<b>4</b>	<b>Assembly .....</b>	<b>13</b>
	General assembly .....	13
	Motor on the rotary drum .....	14
	Hydraulic Chute Kit: Motor .....	15
<b>5</b>	<b>Start-up .....</b>	<b>16</b>
	Basic Start-up Procedures .....	16
<b>6</b>	<b>Maintenance .....</b>	<b>17</b>
	General maintenance .....	17
<b>7</b>	<b>Storage .....</b>	<b>18</b>
<b>8</b>	<b>Trouble Shooting .....</b>	<b>19</b>
<b>9</b>	<b>Specifications .....</b>	<b>20</b>
<b>10</b>	<b>Parts List .....</b>	<b>22</b>
	Snowblower PGS-1020TRC .....	22
	Semi-industrial Chute PSIG-92104 .....	25
	Industrial Chute PCG-92104 .....	27
	Hydraulic telescopic chute PCT-92104 .....	29
	Hydraulic telescopic chute PCTC-INDR .....	31
	Options .....	34
	P.T.O. Shaft T90 # 9475 .....	36
	P.T.O. Shaft V90 # 9598, 9599 & 9604 .....	37
	Gear Box # 9307 .....	38
	Reduction Gear Box PR-91054 # 9575 150 HP .....	39
	Reduction Gear Box PR3G200-2 # 9721 200 HP .....	40
	Cylinder 25TR08 .....	41
	Cylinder 15PC32 .....	42
	Cylinder 15PL12 .....	43
	Hydraulic Motor MLH-315 .....	44
<b>11</b>	<b>Torque Chart .....</b>	<b>45</b>
<b>12</b>	<b>Warranty .....</b>	<b>46</b>



---

---

# INTRODUCTION

---

## CONGRATULATIONS!

Thank you for choosing PRONOVOST. We are confident this equipment will meet your requirements in terms of quality, performance and reliability.

This manual was prepared to assist you in the safe operation of your new Snowblower. It contains important information which will help you achieve excellent returns with your Snowblower for years to come.

Please read this manual completely before operating your Snowblower and keep it for future reference.

Before starting the machine, you or any other person who will be operating the Snowblower must familiarize yourself with the safety recommendations and the operating instructions. Please read carefully and be sure to understand and follow all recommendations and procedures.

In this manual, the right and left sides are identified as shown on Figure 1.

If you require additional information on your Snowblower, please contact your PRONOVOST Dealer.

**NOW** take a moment to enter the model, serial number and the date of purchase of your Snowblower in the space provided.

When ordering parts from your Dealer, please refer to these numbers for a fast and efficient service. Use PRONOVOST parts for replacement.

The model and serial numbers are on the name plate shown on Fig. 1.

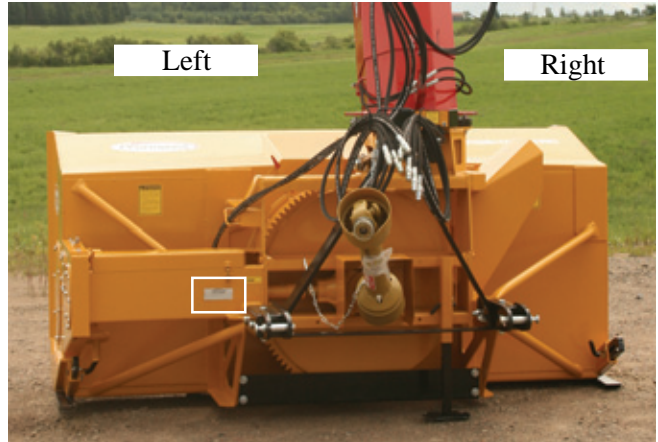

Figure 1

MODEL: \_\_\_\_\_ ✍

SERIAL NO: \_\_\_\_\_ ✍

DATE OF PURCHASE: \_\_\_\_\_ ✍

---

---

# ***SAFETY***

---

## ***GENERAL SAFETY***

**2**

### **WHEN YOU SEE THIS SYMBOL**



**ATTENTION!**

**BE ALERT  
YOUR SAFETY IS INVOLVED**

This symbol «**SAFETY ALERT**» is used in this manual and on the safety decals on the Snowblower. It warns you of the possibility of danger. Carefully read, understand and follow all safety recommendations before operating the Snowblower.

- 1) Careful operation is the best assurance against accidents. Carefully read this manual and follow all recommendations before operating your Snowblower. It is the owner's responsibility to make sure that anyone who will operate the Snowblower will read this manual before operating the equipment.
- 2) Familiarize yourself with all controls and always be ready to stop the Snowblower quickly in case of emergency.
- 3) Never let a child operate the Snowblower.
- 4) Do not modify the Snowblower. Any non authorized modification may affect the efficiency and/or safety of the equipment and will automatically void the warranty.
- 5) Never operate the Snowblower with defective parts or if damaged in any way. Have it repaired before operating.
- 6) Make sure all fasteners are in place and properly secured or tightened. Refer to torque chart on page 45.
- 7) Avoid wearing loose fitting clothing when working with the Snowblower. These could get entangled in moving parts of the equipment and cause accidents.

- 8) Prolonged exposure to noise may hamper hearing. Protect yourself by wearing adequate protection devices.
- 9) Hydraulic fluids under pressure can damage your skin. Do not use your hands to locate a leak.
- 10) Before the beginning of the snow season, inspect all areas where the Snowblower will be used and remove any object which may cause an accident and/or damage the equipment.
- 11) Never operate your Snowblower in poor visibility or without proper lighting conditions.

### ***SAFETY IN OPERATION***

- 1) Be sure there are no obstructions around the equipment and that no one stands near the equipment when in operation.
- 2) Do not operate an engine in a confined or non ventilated area.
- 3) Do not perform any adjustments, cleaning, maintenance or repairs with the engine running. The engine must be stopped and the P.T.O. disengaged. Preferably remove the key from the ignition.
- 4) Wear adequate clothing when working in cold or windy conditions.
- 5) Adjust skid shoes for proper ground clearance of scraper blade, especially in rough terrain or soft ground conditions.
- 6) Before operating, make sure the P.T.O. is properly installed and secured.
- 7) Before starting-up the Snowblower, make sure the auger and drum areas are free of ice.
- 8) Put P.T.O. control in neutral position before starting engine.
- 9) Keep hands, feet and clothing away from moving parts of the Snowblower. Stay away from the discharge chute.

---

---

## ***SAFETY (cont'd)***

---

- 10) Before unplugging the chute, always disengage the P.T.O., stop the engine and relieve all hydraulic pressures.
- 11) Do not operate in excessive inclined conditions. Be careful when turning in slopes.
- 12) Never operate your Snowblower with missing guards or without protective devices in place.
- 13) Do not operate your Snowblower near buildings, windows or other vehicles without prior and proper adjustment of the chute deflector.
- 14) Never aim discharge chute towards people or animals. This may cause serious injuries.
- 15) Always reduce operating speed in slippery conditions.
- 16) Be careful when backing-up, make sure you have good visibility.
- 17) Always be on the lookout for objects which may enter the snowblower.
- 18) If undue vibrations are felt, disengage the P.T.O., stop the motor and look for the cause of the vibration. Vibration is usually the indication of a problem.
- 19) At the end of the operation, disengage the P.T.O., lower the Snowblower, put transmission in neutral, apply parking brake, stop engine and remove the key from the ignition.

### ***SAFETY WITH MAINTENANCE***

- 1) Perform the Snowblower maintenance according to recommendations contained in this manual.

- 2) Stop engine and relieve all hydraulic pressures before doing inspection, maintenance or repairs.
- 3) Never perform any work under the Snowblower while it is supported only by the tractor's hydraulic system. It must be completely supported by wooden blocks or other safe means.

### ***SAFETY IN TRANSPORT***

- 1) On public roads, use proper safety lights and check local regulations.
- 2) Be alert while driving on the road. Never carry passengers.
- 3) Always disengage P.T.O. while moving from one area of work to another.
- 4) It is recommended to use both brake pedals simultaneously for better control.
- 5) The recommended road speed should be such as to maintain full control over steering and braking.
- 6) Be careful while backing up, make sure you have good visibility.

### ***SAFETY IN STORAGE***

- 1) Provide adequate supports to prevent any accidental overturning of the Snowblower.
- 2) Do not let children play in the area where the Snowblower is stored.

**2**

# DECALS

## SAFETY DECALS

The safety decals are affixed wherever special safety precautions are indicated. Locate them on the machine and read them carefully. If a decal is damaged, lost or illegible, install a new one. The following photos indicate where each one must be installed.

3

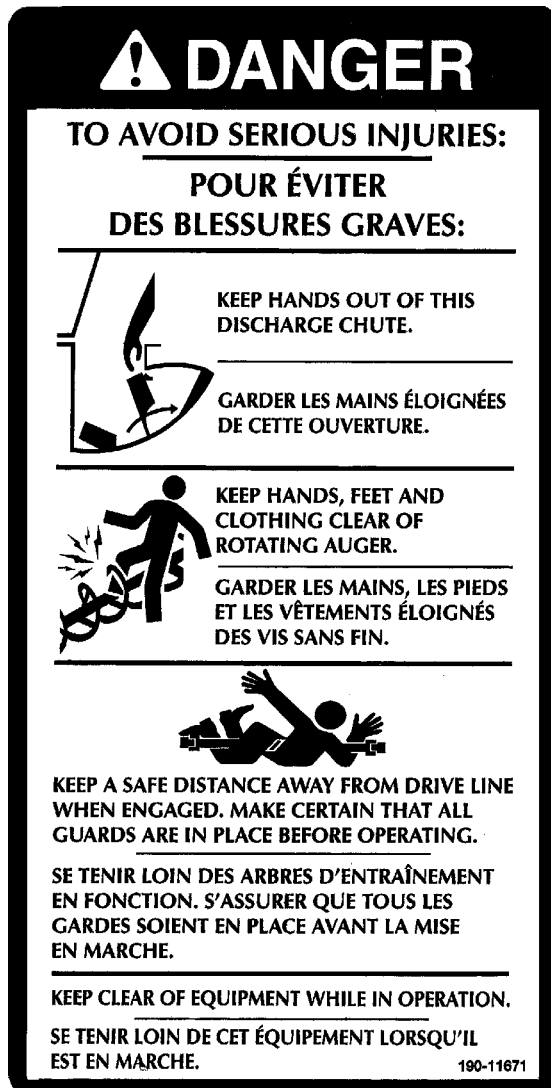

Figure 2  
Decal A

Part no.: 190-11671



Figure 3

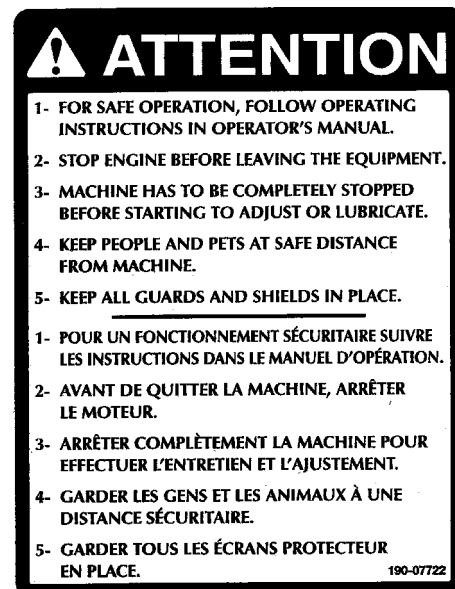

Figure 4  
Decal B

Part no.: 190-07722

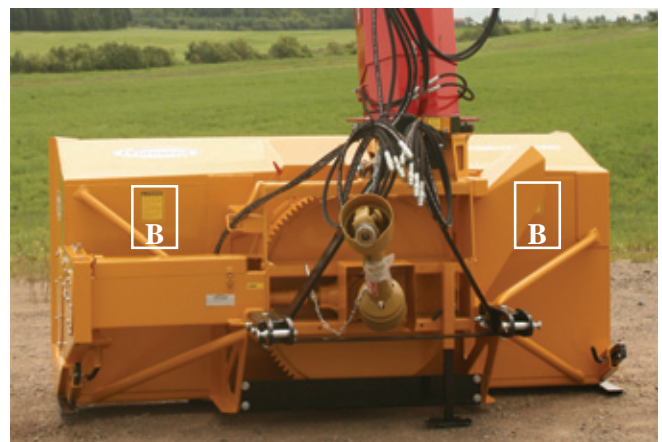

Figure 5



## DECALS (cont'd)



Figure 6

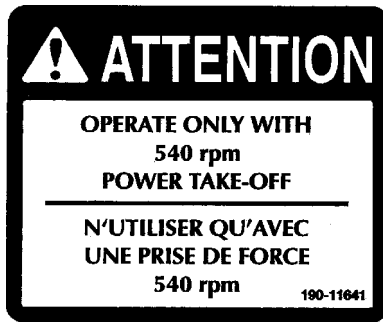

Figure 7  
Decal C

Part no.: 190-11641

If your snowblower is equipped with a reduction gear box, the decal C will be the one shown below.



Figure 8  
Decal C

Pièce no.: 190-11651

Decal E in Fig. 9 is located directly on the P.T.O. shaft. It is not visible when the safety shield is in place. It must never be visible when you operate the equipment.



Figure 9  
Decal E

Part no.: A108

3

# DECALS (cont'd)

3



190.000.215

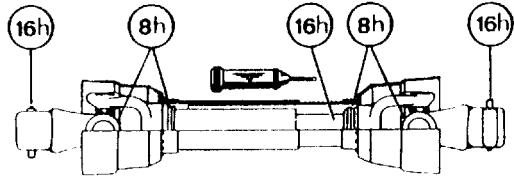

Figure 10  
Decal F

Part no.: A 109

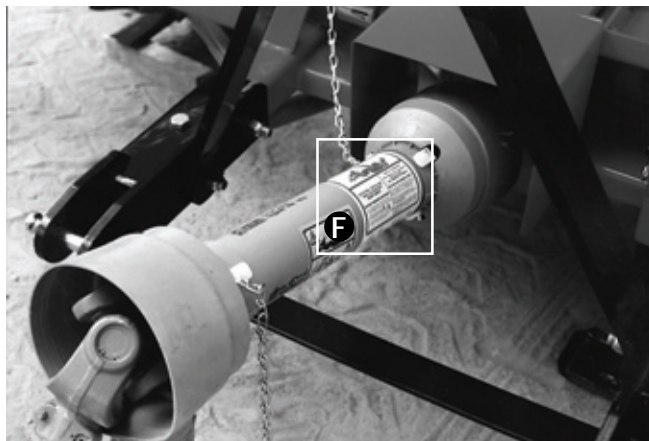

Figure 11



Figure 12  
Decal D

Part no.: A103

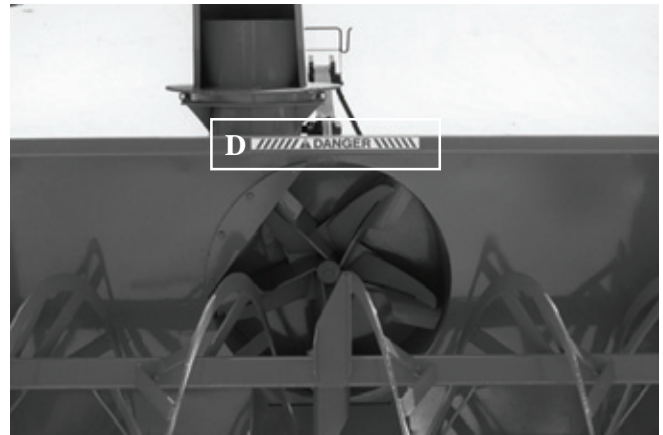

Figure 13



Figure 14  
Decal G

Part no.: 190-10991

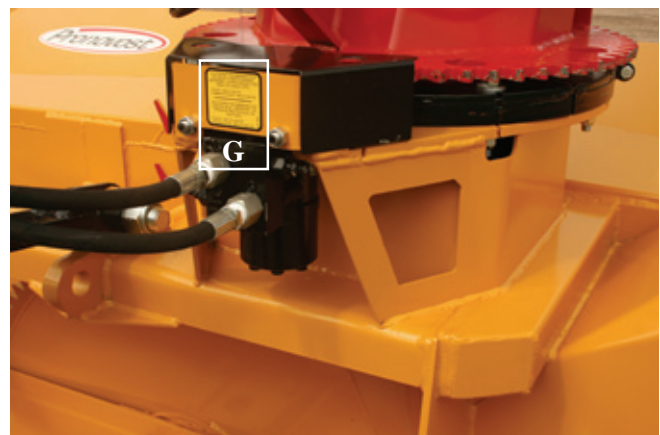

Figure 15

# DECALS (cont'd)

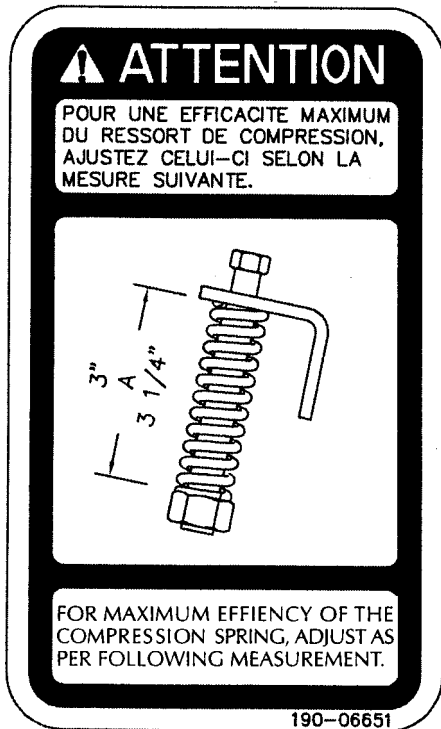

Figure 16  
Decal H Part no.: 190-06651



Figure 17

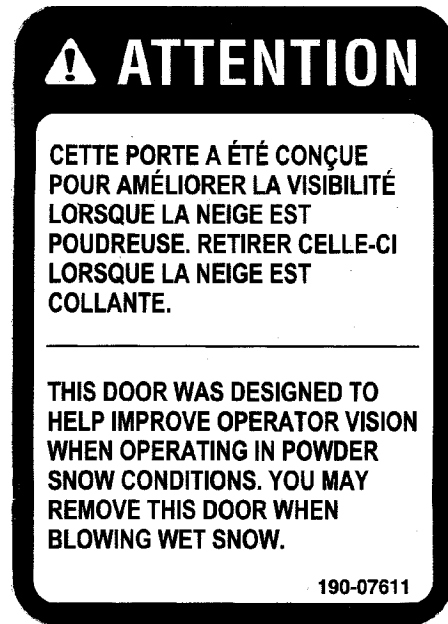

Figure 18  
Decal J Part no.: 190-07611



Figure 19

# DECALS (cont'd)

## MAINTENANCE DECALS

The maintenance decals indicate the points requiring lubrication. Refer to maintenance section for more details.

**3**



A 105

Figure 20



A 106



Figure 23

Decal L

Part no.: 190-11581



Figure 21

Decal K

Part no.: 190-11591



Figure 24

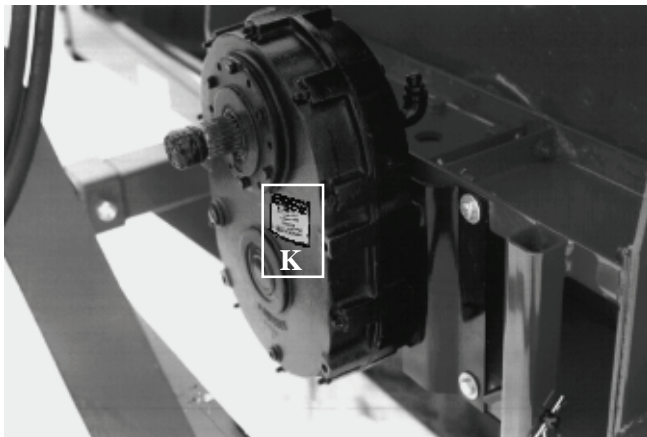

Figure 22



Figure 25



---

# ASSEMBLY

---



Figure 26

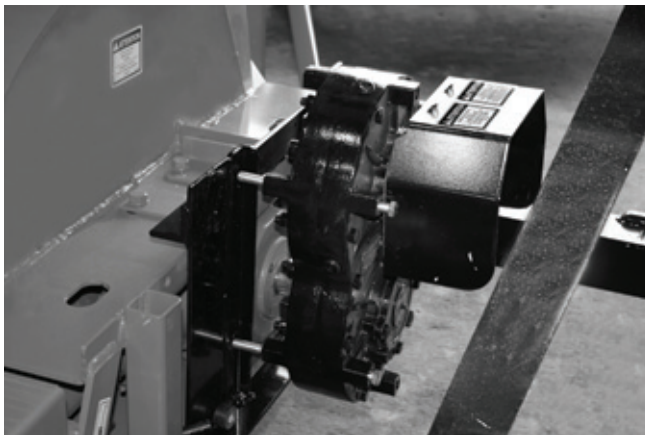

Figure 27



Figure 28

## ASSEMBLY

- 1) The Snowblower is shipped partly assembled.
- 2) Install 3-point system according to the model of your Snowblower. (See section 10 for parts numbers). Use the holes most convenient to the type of tractor used (Fig. 26).
- 3) If your snowblower is equipped with the optional 1000 to 540 RPM reducer, install it on the gear box with the plate included (Fig. 27).
- 4) Install P.T.O. shaft with the shear pin end onto the Snowblower gear box. Then attach safety shield support chain as shown (Fig. 28). **WARNING:** The telescoping tubes of the drive shaft must never be allowed to bottom out while maintaining a minimum overlap of 6 inches.
- 5) If equipped with a rotating drum, please refer to page 14 for installation instructions.
- 6) For the installation of the chute rotation mechanism, please refer to page 15.

4

---

---

## ***ASSEMBLY (cont'd)***

---



**4**

Figure 29

### ***MOTOR ON THE ROTARY DRUM***

- 1) Install the mounting plate tightening the bolts lightly.
- 2) Bolt hydraulic motor in place pointing the oil outlets to the exterior and install sprocket (Fig. 29).
- 3) Using the take-up screws, adjust gear to mesh without bottoming.
- 4) Tighten mounting plate bolts.
- 5) It is important that the cushion valve furnished be installed. Cushion valve has been pre set in plant at 1600 psi.

---

## ASSEMBLY (cont'd)

---

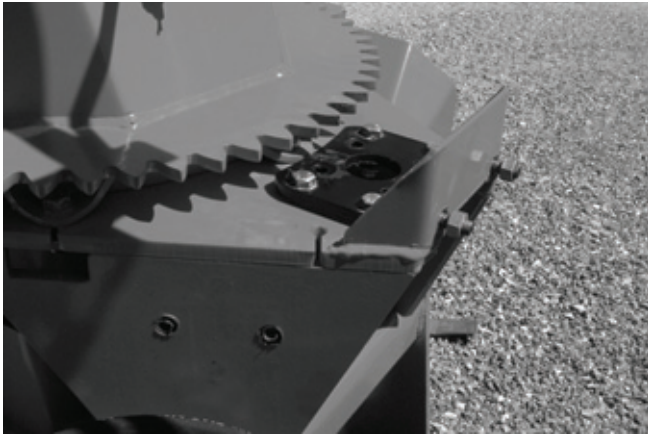

Figure 30

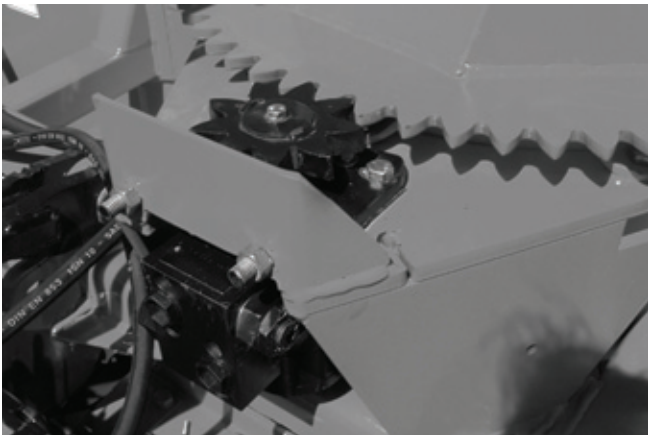

Figure 31



Figure 32

### **HYDRAULIC CHUTE ROTATION Motor**

- 1) Install U-shaped UHMW piece , place chute on Snowblower and secure with retaining bracket and bolts provided.
- 2) Install the mounting plate; put the required spacers between mounting plate and base of chute (see p. 26 to 31 for chute model). Do not tighten the bolts immediately, they will be tightened at final adjustment (Fig. 30).
- 3) Install motor and 9 tooth gear. The thickness of the 9 tooth gear is slightly more than the ring-gear. Make sure it exceeds on both sides of the ring gear (Fig. 31).
- 4) Using the take-up screws, adjust gear to mesh without bottoming. Tighten mounting plate bolts.
- 5) Install guard. It is important that the cushion valve furnished with your chute rotation kit be installed. Cushion valve has been pre set in plant at 1200 psi. (Fig. 32).

4

---

# STARTING-UP

---



Figure 33

5



Figure 34



Figure 35

## START-UP PROCEDURES

- 1) **Check** oil level in **gearbox** and in speed reducer if so equipped. Use **SAE 80W90** gear box oil.
  - 2) **Check** oil level in **auger drive chain box**. Fill to level plug. Use **SAE 80W90** oil (Fig. 33).
  - 3) Lubricate all points with a good quality multipurpose grease.
  - 4) Check chain take-up adjustment. The spring maintaining the tension must be compressed to a length between 3" and 3 1/4".
  - 5) Verify for adequate tightness of all fastening devices. Refer to torque chart on page 45.
  - 6) Adjust skid shoes according to ground conditions (Fig. 33).
  - 7) Following the installation of the Snowblower on the tractor, **do not forget** to lift the storage support (Fig. 34).
  - 8) Make sure of a 540 RPM input to your snowblower, or 1000 RPM if your snowblower is equipped with a 1000/540 RPM speed reducer.
  - 9) Check impeller adjustment. The tip of the blades should be approximately 1/8" to 3/16" from the discharge wall of the drum. If necessary, adjust with the take-up screws provided (Fig. 35).
- If your snowblower is equipped with the optional speed reducer**
- 10) **Check** oil level in **speed reducer**. Adjust to required oil level as per drawing in Parts List section. Use **Enduratex EP-68/220** oil or equivalent.



---

# MAINTENANCE

---

## GENERAL MAINTENANCE

- 1) Wipe off all grease fittings with a clean cloth before adding grease in order to avoid injecting dirt and sand.
- 2) Repair or replace damaged grease fittings.
- 3) Lubricate all grease fittings every 8 hours of operation.
- 4) Lubricate P.T.O. shaft as indicated below:

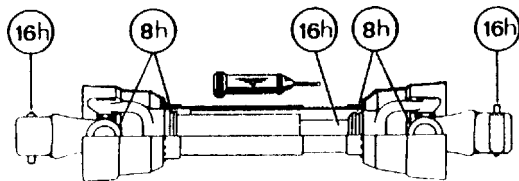

Pull out the P.T.O. And lubricate between the two tubes with low temperature grease. Drive line tubes must slide easily even in cold weather. Clean off old hardened grease and apply fresh grease as needed.

- 5) **Check** oil level in **gear box** once a month. Adjust to required oil level as per drawing in Parts List section. Use **SAE 80W90** oil.
- 6) **Check** oil level in **auger drive chain box** once a month. Fill to level plug, figure 33 page 16. Use **SAE 80W90** oil.
- 7) Check tension of drive chain every 24 hours of operation and adjust if necessary.
- 8) Check for tightness of bearing collars every 48 hours of operation.
- 9) **Change gearbox** oil once a year. Adjust to required oil level as per drawing in Parts List section. Use **SAE 80W90** oil.
- 10) **Change** the **auger drive chain box** oil once a year. Fill to level plug, figure 33 page 16. Use **SAE 80W90** oil.

11) Check all nuts and bolts once a year. If necessary use torque chart on page 45.

12) Standard scraper blades are reversible. Reverse when one edge is worn out.

13) For the auger drive shaft, always use a grade 5 shear bolt.

14) For the PTO shaft:

**AT 540 RPM** on a PTO size 90, the shear bolt is 12 mm, grade 10.9, part number **9207**.

**AT 1000 RPM**, the shear bolt must be changed, you must use a 12 mm, grade 8.8 bolt that has been reduced to 10 mm at the point of rupture, part number **9207-375**.

15) UHMW slides do not require lubrication except at the end of the season in order to prevent corrosion of steel components that are in contact with the UHMW material.

### If your snowblower is equipped with the optional speed reducer

- 16) After 10 working hours, the chain's adjustment (if applicable) must be checked and every 100 working hours. Please refer to section: Maintenance on Speed Reducer (with chains).
- 17) **Check** oil level in **speed reducer** once a month. Adjust to required oil level as per drawing in Parts List section. Use **Enduratex EP-68/220** oil or equivalent.
- 18) **Change** the oil of the **speed reducer** once a year. Adjust to required oil level as per drawing in Parts List section. Use **Enduratex EP-68/220** oil or equivalent.

---

---

## *STORAGE*

---

- 1) Store the Snowblower in a cool, dry place.
- 2) Support the Snowblower with wooden blocks.
- 3) Keep all piston rods in the retracted position. This will assure better protection against the elements.
- 4) Clean your Snowblower.
- 5) Thoroughly inspect all parts of the Snowblower. Replace or repair worn or defective parts.
- 6) Touch-up or repaint if necessary.
- 7) Lubricate all points before storage.

# TROUBLESHOOTING

## P.T.O. SHAFT

PROBLEM	POSSIBLE CAUSE	CORRECTION
<ul style="list-style-type: none"> <li>- Premature wear of U-joints and/ or bluish color of cross journals.</li> </ul>	<ul style="list-style-type: none"> <li>- Insufficient lubrication.</li> <li>- Excessive working angle.</li> <li>- Poor quality lubricant.</li> </ul>	<ul style="list-style-type: none"> <li>- Follow lubrication recommendations.</li> <li>- Replace defective U-joints.</li> <li>- Make sure the Snowblower inlet face is perpendicular to the ground and if possible readjust 3-point hitch in order to position the Snowblower further away from tractor.</li> <li>- Use high quality lubricant.</li> </ul>
<ul style="list-style-type: none"> <li>- Gripping or premature wear of telescoping members.</li> </ul>	<ul style="list-style-type: none"> <li>- Too much sliding under load.</li> <li>- Tube overlap too-short: minimum recommended is 6".</li> <li>- Insufficient lubrication.</li> <li>- Contaminants (sand, etc.).</li> </ul>	<ul style="list-style-type: none"> <li>- Avoid raising Snowblower while in operation.</li> <li>- Readjust 3-point hitch in order to position the Snowblower closer to the tractor.</li> <li>- Follow lubrication recommendations.</li> <li>- Replace defective telescopic members.</li> </ul>
<ul style="list-style-type: none"> <li>- Damaged or jammed locking pin or bolt.</li> </ul>	<ul style="list-style-type: none"> <li>- Pin or orifice contaminated by sand, ice, etc.</li> <li>- Telescoping members too long, exerting pressure on locking device.</li> </ul>	<ul style="list-style-type: none"> <li>- Clean and grease.</li> <li>- Readjust 3-point hitch in order to position the Snowblower further away from tractor or shorten tubes.</li> </ul>
<ul style="list-style-type: none"> <li>- Premature wear of guard tube bearing ring.</li> </ul>	<ul style="list-style-type: none"> <li>- Lack of lubrication.</li> <li>- Wrong installation of guard chain.</li> <li>- Part of the guard in contact with the equipment.</li> </ul>	<ul style="list-style-type: none"> <li>- Follow lubrication instructions.</li> <li>- Adjust chain to prevent interference between guard &amp; equipment.</li> <li>- Replace worn or damaged bearing rings.</li> </ul>
<ul style="list-style-type: none"> <li>- Cut or deformed safety guard tubes.</li> </ul>	<ul style="list-style-type: none"> <li>- Tubes in contact with the equipment.</li> </ul>	<ul style="list-style-type: none"> <li>- Eliminate any interference between tubes and equipment or tractor.</li> <li>- Replace damaged tubes.</li> </ul>

# ***TROUBLESHOOTING (cont'd)***

## ***SNOWBLOWER***

<b>PROBLEM</b>	<b>POSSIBLE CAUSE</b>	<b>CORRECTION</b>
- The snow is not being thrown as far as usual.	- Tractor RPM too low. - Gap too wide between impeller blade tip and drum outlet wall. - Insufficient tractor HP.	- Raise P.T.O. speed to a minimum of 540 RPM. - Adjust impeller blades closer to drum outlet (1/8" to 3/16"). - Reduce travel speed.
- Frequent plugging of discharge chute.	- Tractor RPM too low. - Tractor RPM reduced too early with snow still in the Snowblower. - Slippage of PTO clutch mechanism. - Wet snow condition.	- Raise P.T.O. speed to a minimum of 540 RPM. - Make sure the Snowblower is completely empty before reducing RPM, especially on tractors with foot controlled RPM. - Repare clutch. - Reduce travel speed. - Remove the chute access panel.
- The impeller will not turn.	- Shear bolt broken on drive shaft.	- Replace shear bolt.
- The auger will not turn.	- Shear bolt broken on drive shaft. - Shear bolt broken on auger drive shaft. - Broken drive chain. - Broken key on motor.	- Replace shear bolt. - Replace shear bolt. - Fix or replace chain. - Replace the key.
- The rotating drum will not turn.	- Ice accumulation. - Wrong hydraulic connections. - Broken key on motor.	- Remove ice. - Check hydraulic connections. - Replace the key.
- The rotating drum will not hold it's position when blowing via the spout	- Cushion valve setting too low - Tension of the spring in drum locking mechanism insufficient	- Reset cushion valve up to 1800 psi (max) - Increase tension of spring by adding shim(s)
- The chute will not turn.	- Ice accumulation. - Wrong hydraulic connections. - Broken key on motor.	- Remove ice. - Check hydraulic connections. - Replace the key.

# SPECIFICATIONS

Model	PGS-1020TRC	
Horse power required	100 to 150 HP	
Approximate performance	950 tons imp./hour (tractor 150 HP)	
Height including telescopic chute PCT in working position	119" retracted (approximately) 149" extended (approximately)	
Height - chute base	50"	
Chute rotation	On UHMW, for hydraulic motor	
Frame height	47 1/2"	
Optional lateral blade cutting height	66" ou 78"	
Working width	102"	
Drum diameter	34"	
Depth of drum	15"	
Drum rotation	On UHMW, for hydraulic motor	
Drum position	Centered	
Drum liner	1/4" in carbon steel 450	
Impeller blades	6 blades x 1/2" standard steel welded	
Size and height of impeller shaft	Diameter 2" - Height 22"	
Impeller speed	540 RPM (CW)	
P.T.O. speed required	540 RPM (CW) or 1000 RPM (CW) optional	
Speed reducer	Optional: 1000/555RPM-200 HP or 220 HP	
Height of speed reducer shaft	14" or 30" (with reducer 150 HP)	
Standard P.T.O. shaft	No. 9 (T90) choice of yoke as required	
Optional P.T.O. shaft	No. 9 multilobe (V90) choice of yoke as required	
Lower auger	Dual band, bolted, 34" diameter, toothed auger	
Upper auger	Not available	
Drive chain	RENOLD No. 100HV in oil bath	
Shear bolt	1 for the impeller + 1 for auger	
<b>Scraper blade</b>	Standard steel 1/2" x 4" rev.	Standard
	Carbon steel 1/2" x 4" rev.	Optional
	Carbon steel 6" x 1/2" sharpened	Optional
	Stainless steel 1/2" x 4" rev.	Optional
<b>Skid shoes</b>	Standard steel (quick adjust)	Standard (2 quick adjust skid shoes)
	Carbon steel (quick adjust)	Optional (2 quick adjust skid shoes)
	Stainless steel (quick adjust)	Optional (2 quick adjust skid shoes)
	Rocktec (quick adjust)	Optional (2 quick adjust skid shoes)
3-point hitch	Category 2	
Frame: sides	Plate 1/4"	
Frame: back	Plate 10 Gauge	
Center of gravity from 3-pt hitch at its shortest	44"	
Rotational force (reference)	169 180 lbs-po	
Weight (with télescopic chute)	3 845 lbs (without reducer)	

Design and specifications subject to change without notice.

# SNOWBLOWER PGS-1020TRC

170-05341R1

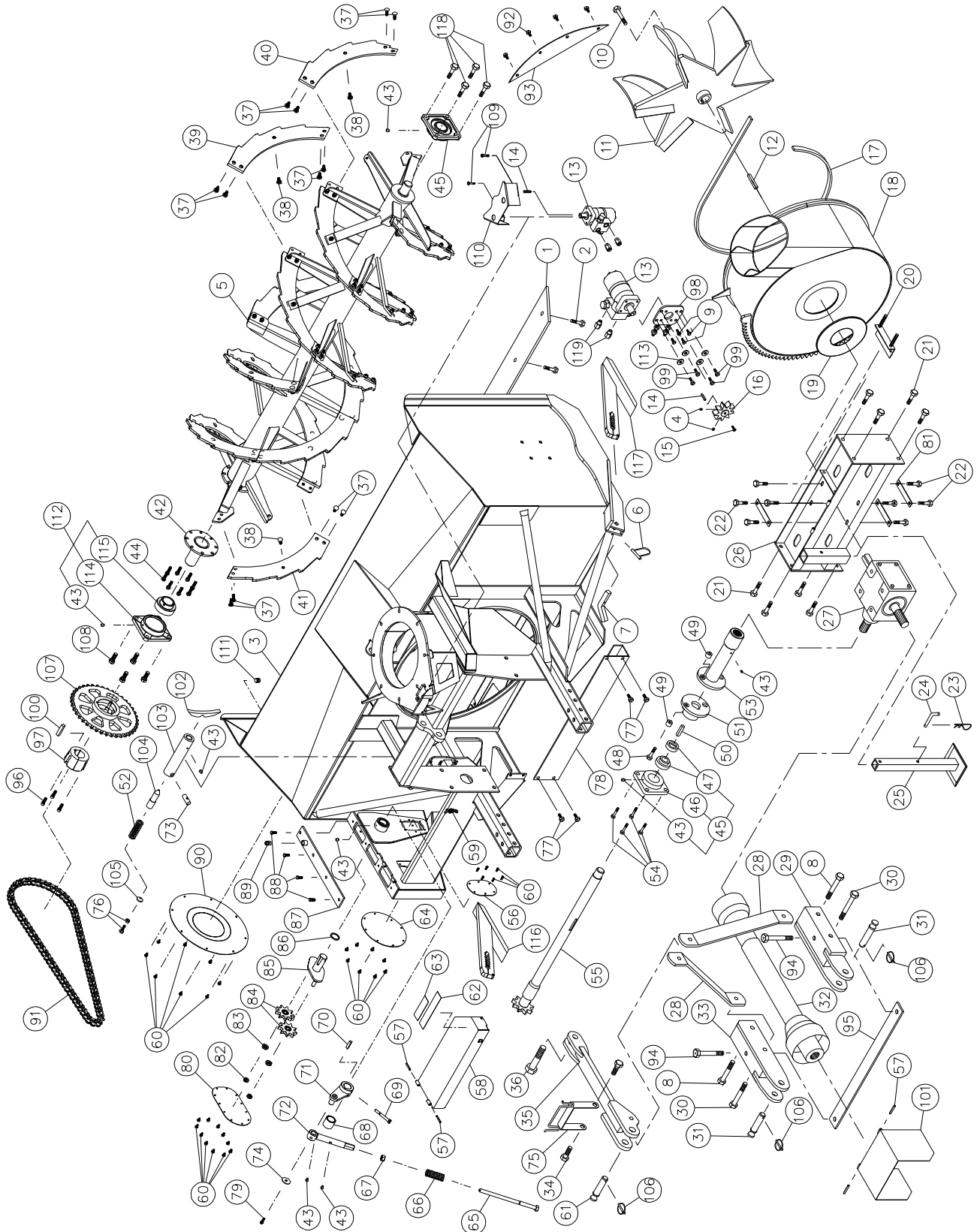

10

# SNOWBLOWER PGS-1020TRC (cont'd)

REF.	PART #	DESCRIPTION	QTY
1	140-15151	Reversible scraper blade 1/2" x 4" x 95" lg	1
2	319-38310	Plow bolt 7/16" NC x 1 3/4" lg + nut & lock washer	10
3	120-07461	Frame	1
4	323-36160	Hexagonal socket set screw 3/8" NC x 3/8" lg	2
5	110-42772	Auger assembly (including #42)	1
6	8112	Lock pin 1/4"	2
7	140-03361	Skid shoes lock	2
8	302-46580	Bolt 3/4" NF x 6" lg + nylon locknut	2
9	301-36250	Bolt 3/8" NC x 1" lg + lock washer	4
10	8228	Bolt 5/8" NC x 1 1/2" lg (ass'd with locktite 242) + lock washer	1
11	110-01623	Impeller 34" ø 6 blades	1
12	9285	Key 1/2" x 1/2" x 4" lg	1
13	MLH-315	Hydraulic motor	opt.
14	8369	Key for hydraulic motor	opt.
15	301-32220	Bolt 1/4" NC x 3/4" lg + lock washer	1
16	110-44331	Sprocket (9 teeth)	1
17	9430	U-shaped UHMW 3/8" x 7/8" x 109 1/4" lg	1
18	110-12855-T1	Rotary drum 34" ø	1
19	9432	UHMW flat washer 3/16" x 8 7/8" i.d. x 12" o.d.	1
20	9428	Adjustment plate for gear box + 4 nuts 1/2" NC	1
21	301-46340	Bolt 3/4" NC x 2" lg + écrou à blocage de nylon	8
22	300-44310	Bolt 5/8" NC x 1 1/2" lg + rondelle de blocage	8
23	Std.	Hitch pin clip 5/32"	1
24	8220	Storage support pin	1
25	9462	Storage support	1
26	9433	Gear box support	1
27	9307	Gear box T-279	1
28	140-05592	3-points side bar	2
29	110-15214	Right lower hitch	1
30	302-46610	Bolt 3/4" NF x 6 1/2" lg + nylon locknut	2
31	9269	Pin category 2	3
32	9475	P.T.O. shaft T90	1
32	9598	P.T.O. shaft V90	opt.
33	110-15213	Left lower hitch	1
34	302-46400	Bolt 3/4" NC x 3" lg + nylon locknut	2
35	110-15531	Upper hitch	1
36	300-54490	Bolt 1 1/4" NC x 4" lg + nylon locknut	1
37	321-40310	Carriage bolt 1/2" NC x 1 1/2" lg + lock washer + nut	76
38	321-40325	Carriage bolt 1/2" NC x 1 3/4" lg + lock washer + nut	14
39	130-71942	Right side ribbon for open flight auger	8
40	130-74191	Right end ribbon for open flight auger	2
41	130-71941	Left side ribbon for open flight auger	8
42	110-40301	Auger hub (auger drive end)	1
43	Std.	Grease fitting 1/4"-28 straight	8
44	300-40325	Bolt 1/2" NC x 1 3/4" lg + nut & lock washer	8
45	HCFS211-32	Bearing 2" + cast iron flange + 1 grease fitting	2
46	FS211	Cast iron flange 4 holes	2
47	HC211-32	Bearing 2" with eccentric collar	2
48	300-38355	Bolt 7/16" NC x 2 1/4" lg + nylon locknut	1
49	150-02501	Bushing 7/16" i.d. x 1" o.d. x 3/4" lg (welded)	2
50	140-08541	Key for auger drive shaft & shearplate (short side)	1
51	110-11361	Side shaft & shear plate (short side)	1
52	9473	Compression spring	1
53	110-43001	Side shaft & shearplate (long side) + splined adaptor (20 splines)	1
54	190-11561	Bolt 5/8" NC x 2" lg (modified) + nylon locknut	4
55	110-42672	Auger drive shaft	1
56	130-75592	Access panel for chain	1
57	Std.	Spring pin 5/16" x 2" lg	4
58	110-44601	Auger drive shaft guard	1
59	8374	Adjustable clamp fastener (welded)	1
60	311-34012	Bolt M10-1.5 x 12 mm lg + flat washer M10 assembled with loctite 242	30

# SNOWBLOWER PGS-1020TRC (cont'd)

REF.	PART #	DESCRIPTION	QTY
61	150-05961	Pin category 2 (top link) .....	1
62	190-11541	Non skid tape .....	1
63	190-11551	Non skid tape .....	1
64	130-61323	Access panel for auger drive shaft .....	1
65	110-39191	Threaded rod for idler adjustment .....	1
66	9687	Compression spring .....	1
67	346-46000	Nut 3/4" NC .....	1
68	160-08421	Aluminium-bronze bushing 1 3/4" i.d. x 2 1/4" o.d. x 2" lg .....	1
69	300-40460	Bolt 1/2" NC x 4" lg GR 12 + nylon locknut .....	1
70	140-12161	Idler key .....	1
71	110-39101	Idler (outside part) .....	1
72	110-17762	Threaded tube for idler adjustment .....	1
73	150-02561	Pin .....	1
74	378-40340	Flat washer 1/2" x 2" .....	1
75	110-15201	Hoses support .....	1
76	300-38340	Bolt 7/16" NC x 2" lg (full length thread) + lock nut .....	1
77	300-40280	Bolt 1/2" NC x 1 1/4" lg + nylon locknut + flat washer .....	4
78	130-06571	Guard for ring gear segment .....	1
79	300-40415	Bolt 1/2" NC x 3 1/4" lg .....	1
80	130-72012	Idler cover .....	1
81	140-10761	Back plate .....	3
82	346-47000	Nylon locknut 3/4" NC thin .....	2
83	160-22371	Spacer .....	2
84	9470	Idler sprocket 100A9 H3/4 .....	2
85	110-35421	Idler (inside part) .....	1
86	OR-224	O-ring 1/8" X 1 3/4" i.d. X 2" o.d. ....	1
87	110-38791	Upper chain guard cover .....	1
88	300-38250	Bolt 7/16" NC x 1" lg + lock washer .....	4
89	9619	Vent plug 1/2" NPT .....	1
90	130-69102	Access panel for auger drive sprocket .....	1
91	190-12051	Chain Renold #100 HV x 106 1/4" (85 links) .....	1
91	59-100 HD	Offset link #100 HV .....	1
91	26A100 HD	Connecting link #100 HV .....	1
92	300-38280	Bolt 7/16" NC x 1 1/4" + nylon locknut .....	4
93	130-05911	Deflector .....	1
94	302-46550	Bolt 3/4" NF x 5 1/2" lg + nylon locknut .....	2
95	140-03561	Brace .....	1
96	318-40310	Allen socket head screw 1/2" NC x 1 1/2" lg .....	3
97	9715	Male adaptor "taper lock" .....	1
98	110-18441	Orbit motor support + 4 nuts 7/16" NC .....	1
99	300-38310	Bolt 7/16" NC x 1 1/2" lg + nylon locknut .....	4
100	140-23961	Key (sprocket for auger) .....	1
101	110-12541	Hinged P.T.O. shroud .....	1
102	130-08441	Stop block for drum lock (welded on drum) .....	1
103	160-03952	Body - drum lock (welded on drum) .....	1
104	150-01542	Latch-pin drum lock .....	1
105	130-08471	Washer .....	1
106	Std.	Lynch pin 1/4" x 1 3/4" .....	3
107	110-40191	Sprocket for auger 100A40 x 1T 6.250" + female adaptor "taper lock" .....	1
108	300-46370	Bolt 3/4" NC x 2 1/2" lg + nylon locknut .....	4
109	300-34280	Bolt 5/16" NC x 1 1/4" lg + nylon locknut .....	2
110	130-14282	Guard .....	1
111	Std.	Magnetic cap 3/8" NPT (disc style) .....	1
112	UCFD213-40	Bearing 2 1/2" + Heavy duty cast iron flange + 1 grease fitting .....	1
113	150-12741	Sturdy flat washer 7/16" .....	4
114	FD213	Cast iron flange 4 holes .....	1
115	UC213-40	Bearing 2 1/2" .....	1
116	110-42701	Skid shoe (left side) .....	1
117	110-42711	Skid shoe (right side) .....	1
118	300-44340	Bolt 5/8" NC x 2" lg + nylon locknut + flat washer 9/16" .....	4
119	RSP-1/16 x 10 ORB	Kit of two unidirectionals restrictors .....	opt.



# SEMI-INDUSTRIAL CHUTE PSIG-92104

170-03455

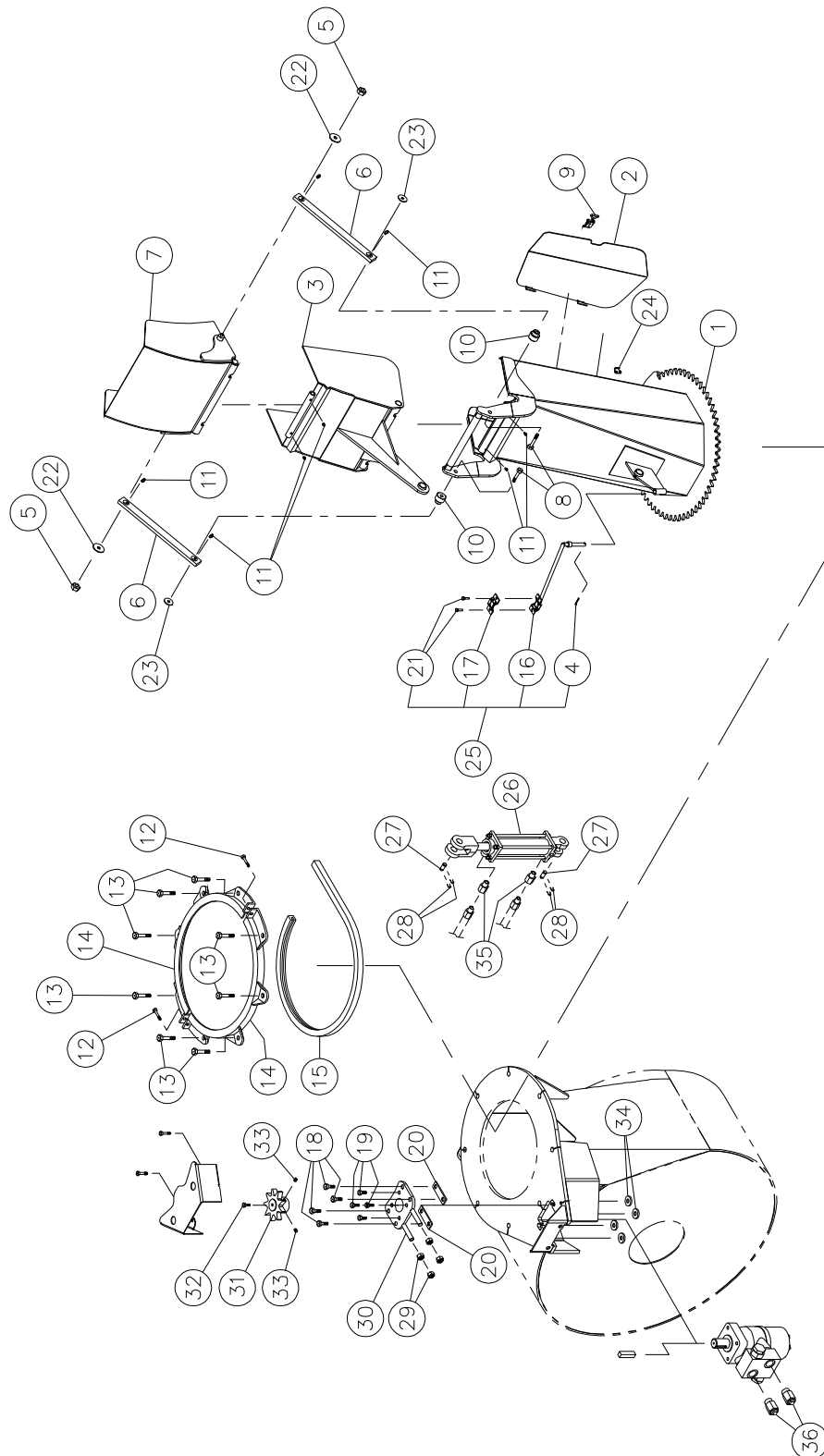

# SEMI-INDUSTRIAL CHUTE PSIG-92104

REF.	PART #	DESCRIPTION	QTY
1	110-22555	Chute base .....	1
2	110-22934	Access panel.....	1
3	110-22232	Lower chute deflector .....	1
4	Std.	Goupille fendue 1/8" x 1" lg.....	1
5	346-36000	Nylon locknut 3/8" NC .....	2
6	140-13931	Connecting rod .....	2
7	110-22242	Upper chute deflector .....	1
8	300-40400	Bolt 1/2" NC x 3" lg + nylon locknut + flat washer .....	2
9	8376	Adjustable clamp fastener (welded) .....	1
10	150-05311	Spacer for connecting rod .....	2
11	Std.	Grease fitting 1/4" - 28 droit .....	8
12	300-34340	Bolt 5/16" NC x 2" lg + nylon locknut .....	2
13	300-40310	Bolt 1/2" NC x 1 1/2" lg + nylon locknut & flat washer .....	8
14	110-00832	Retaining bracket .....	2
15	9359	U-shaped UHMW +/- 16 1/2" d.i. ....	1
16	110-01112	Hoses support rod .....	1
17	140-13071	Hoses support plate .....	1
18	300-38250	Bolt 7/16" NC x 1 3/4" lg + nylon locknut & flat washer .....	4
19	300-36250	Bolt 3/8" NC x 1" lg + lock washer .....	4
20	140-09571	Spacer 1/8" x 1" x 3 1/4" lg .....	2
21	300-32250	Bolt 1/4" NC x 1" lg + nylon locknut .....	2
22	378-36500	Upper flat washer for connecting rod .....	2
23	376-40000	Lower flat washer for connecting rod .....	2
24	8377	Hook for clamp fastener (welded) .....	1
25	TSB-74104	Hoses support for deflector cylinder .....	opt.
26	25TR08	Cylinder .....	opt.
27	6004	Clevis pin 1" x 3 1/8"(4) .....	opt.
28	Std.	Hairpin cotter 7/8" (4) .....	opt.
29	346-38000	Nut 7/16" NC .....	4
30	110-20811	"Orbit" motor support .....	1
31	110-44331	Sprocket 9 teeth .....	1
32	300-32220	Bolt 1/4" NC x 3/4" lg + lock washer .....	1
33	323-36160	Hexagonal socket set screw 3/8" NC x 3/8" lg + lock washer .....	2
34	150-12741	Flat washer 7/16" heavy-duty .....	4
35	RSP-1/16x08 NPT	Kit of two unidirectional restrictors 1/2" NPT .....	opt.
35	RSP-1/16x08 NPT	Kit of two unidirectional restrictors 3/8" NPT .....	opt.
36	RSP-1/16x10 ORB	Kit of two unidirectional restrictors 10 ORB .....	opt.

# INDUSTRIAL CHUTE PCG-92104

170-03485

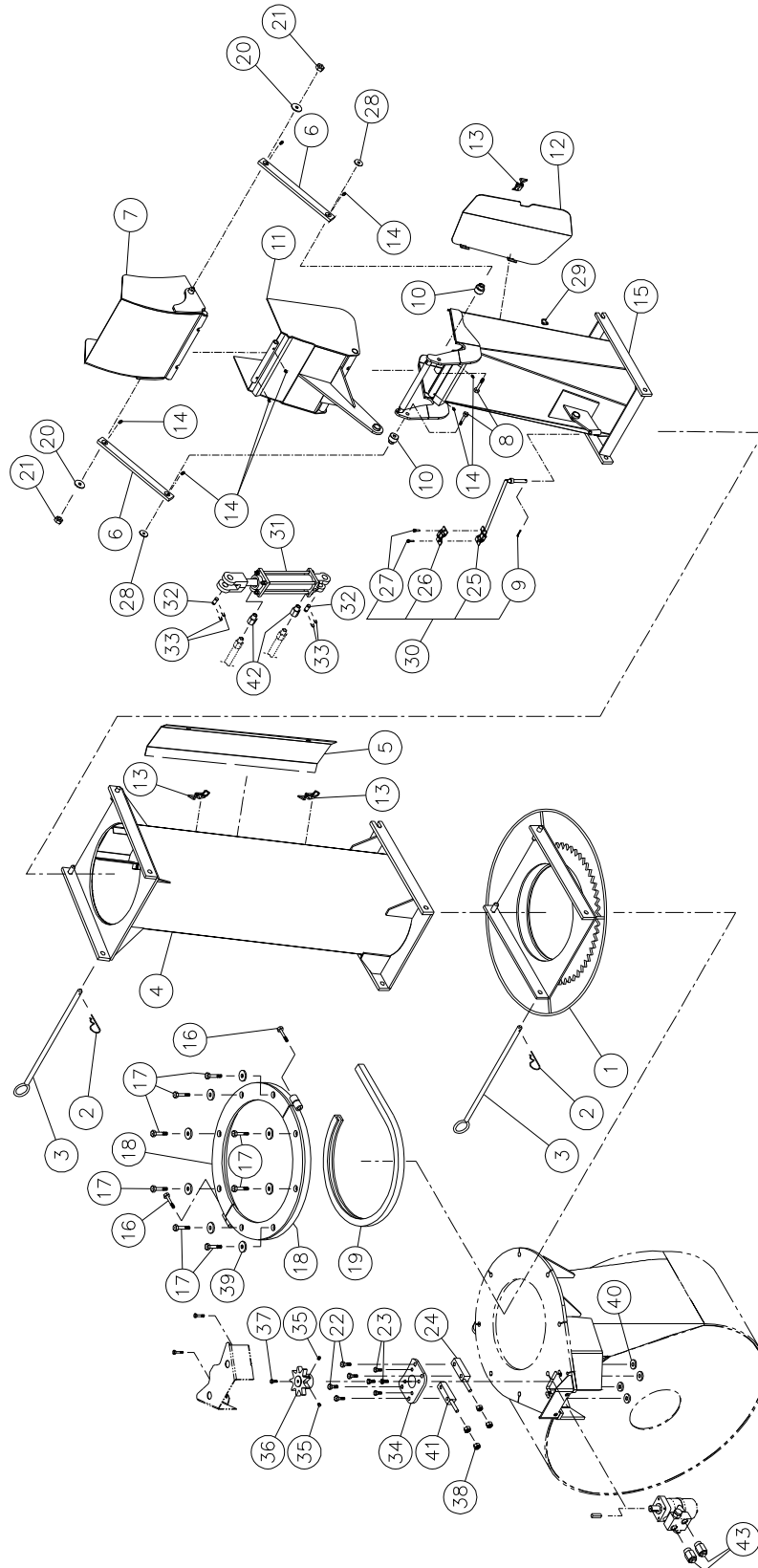

# INDUSTRIAL CHUTE PCG-92104

REF.	PART #	DESCRIPTION	QTY
1	110-00681	Chute adaptor with quick attach .....	1
2	Std.	Hitch pin clip 5/32" .....	2
3	9414	Pin for quick attach (adaptor & extension) .....	2
4	PR-92104P-2	Extension 24" .....	opt.
4	PR-92104P	Extension 48" .....	opt.
5	110-22942	Access panel for extension 24" # PR-92104P-2 .....	opt.
5	110-22952	Access panel for extension 48" # PR-92104P .....	opt.
6	140-13931	Connecting rod .....	2
7	110-22242	Upper deflector .....	1
8	300-40370	Bolt 1/2" NC x 2 1/2" lg + nylon locknut (thin) .....	2
9	Std.	Cotter pin 1/8" x 1" lg .....	1
10	150-05311	Spacer for connecting rod .....	2
11	110-22232	Lower deflector .....	1
12	110-22934	Access door .....	1
13	8376	Adjustable clamp fastener (welded) .....	1
14	Std.	Grease fitting 1/4" - 28 straight .....	8
15	110-22755	Chute base .....	1
16	300-38400	Bolt 7/16" NC x 3" lg + nylon locknut .....	2
17	300-40415	Bolt 1/2" NC x 3 1/4" lg + nylon locknut .....	8
18	110-12351	Retaining bracket .....	2
19	190-03381	U-shaped UHMW +/- 16" i.d. ....	1
20	378-36500	Upper flat washer for connecting rod .....	2
21	346-36000	Nylon locknut 3/8" NC .....	2
22	300-38385	Bolt 7/16" NC x 2 3/4" lg + nylon locknut .....	4
23	300-36250	Bolt 3/8" NC x 1" lg + lock washer .....	4
24	110-38321	Right spacer .....	1
25	110-01112	Hoses support rod .....	1
26	140-13071	Hoses support plate .....	1
27	300-32250	Bolt 1/4" NC x 1" lg + nylon locknut .....	2
28	378-37500	Lower flat washer for connecting rod .....	2
29	8377	Hook for clamp fastener (welded) .....	1
30	TSB-74104	Hoses support for deflector cylinder .....	opt.
31	25TR08	Cylinder .....	opt.
32	6004	Clevis pin 1" x 3 1/8"(4) .....	opt.
33	Std.	Hairpin cotter 7/8" (4) .....	opt.
34	130-08152	"Orbit" motor support .....	1
35	323-36160	Hexagonal socket set screw 3/8" NC x 3/8" lg .....	2
36	110-44331	Sprocket 9 teeth .....	1
37	300-32220	Bolt 1/4" NC x 3/4" lg + lock washer .....	1
38	346-38000	Nut 7/16" NC .....	4
39	150-12731	Flat washer 1/2" heavy-duty .....	16
40	150-12741	Flat washer 3/8" heavy-duty .....	4
41	110-38322	Left spacer .....	1
42	RSP-1/16x08 NPT	Kit of two unidirectional restrictors 1/2" NPT .....	opt.
42	RSP-1/16x08 NPT	Kit of two unidirectional restrictors 3/8" NPT .....	opt.
43	RSP-1/16x10 ORB	Kit of two unidirectional restrictors 10 ORB .....	opt.

# HYDRAULIC TELESCOPIC CHUTE PCT-92104

170-04071R4

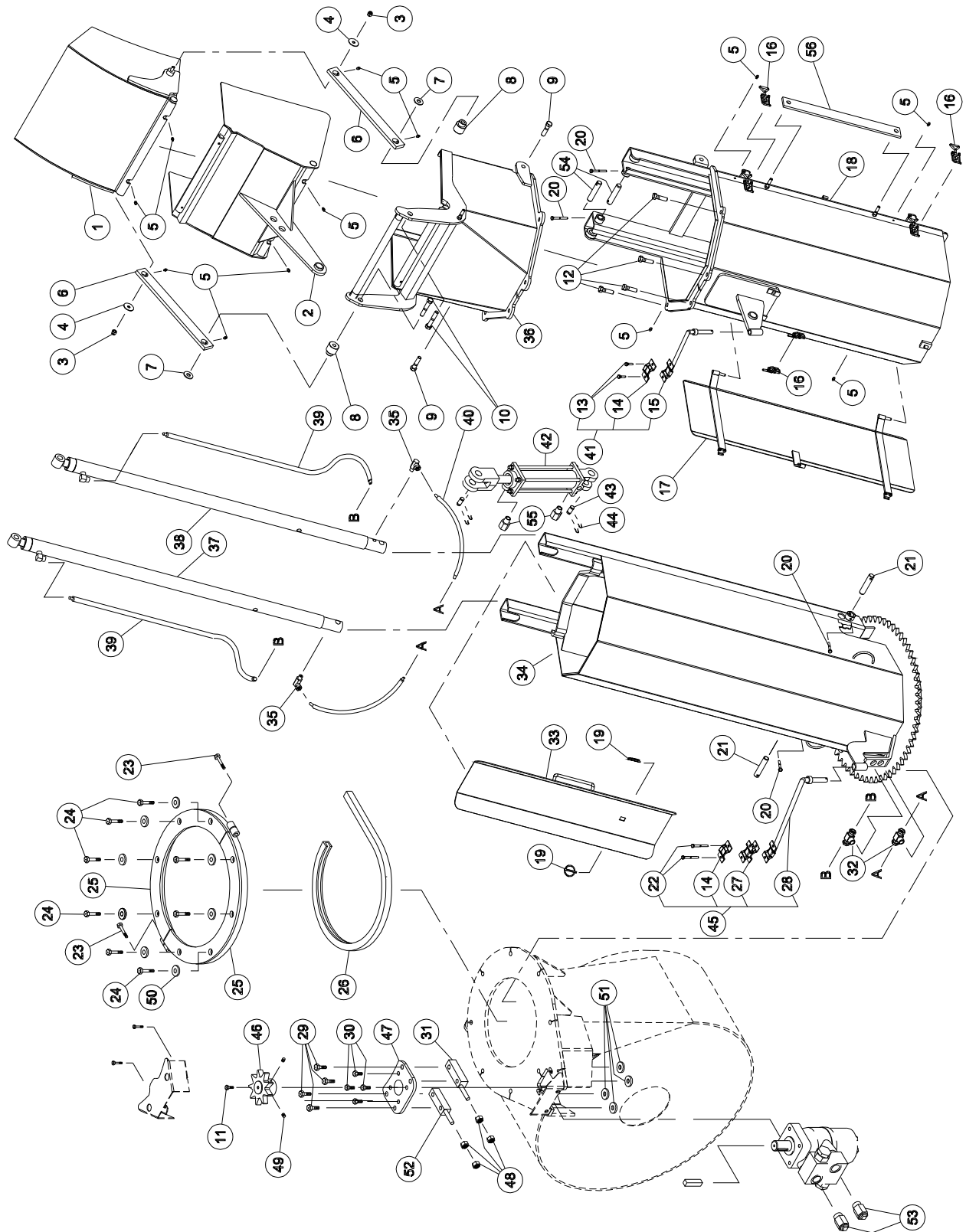

# HYDRAULIC TELESCOPIC CHUTE PCT-92104

REF.	PART #	DESCRIPTION	QTY
1	110-29112	Upper chute deflector .....	1
2	110-29121	Lower chute deflector .....	1
3	346-36000	Nylon locknut 3/8" .....	2
4	378-36500	Flat washer 3/8" i.d. x 1 1/2" o.d. ....	2
5	Std.	Grease fitting 1/4"-28 straight .....	12
6	140-13931	Connecting rod .....	2
7	378-37500	Washer 1/2" i.d. x 1 3/8" o.d. ....	2
8	150-05311	Spacer for connecting rod .....	2
9	300-40340	Bolt 1/2" NC x 2" lg + nylon locknut .....	2
10	300-40380	Bolt 1/2" NC x 2 3/4" lg + nylon locknut .....	2
11	300-32220	Bolt 1/4" NC x 3/4" lg + lock washer .....	1
12	300-40325	Bolt 1/2" NC x 1 3/4" lg + 2 washers + nylon locknut .....	4
13	300-32250	Bolt 1/4" NC x 1" lg + nylon locknut .....	2
14	140-13071	Hoses mounting plate .....	2
15	110-01122	Mounting support plate for upper extension .....	1
16	8376	Clamp fastener .....	3
17	110-29391	Access door for upper extension .....	1
18	110-26642	Upper extension .....	1
19	Std.	Lynch pin 3/16" x 1 1/4" .....	2
20	300-32325	Bolt 1/4" NC x 1 3/4" lg + nylon locknut .....	4
21	150-12701	Pin .....	2
22	300-32370	Bolt 1/4" NC x 2 1/2" lg + nylon locknut .....	2
23	300-38400	Bolt 7/16" NC x 3" lg + nylon locknut .....	2
24	300-40415	Bolt 1/2" NC x 3 1/4" lg + nylon locknut .....	8
25	110-12351	Retaining bracket .....	2
26	190-03381	U-shaped UHMW + - 16" approx. inside diameter .....	1
27	110-20611	Hoses mounting plate .....	1
28	110-04982	Mounting support plate for lower extension .....	1
29	300-38370	Bolt 7/16" NC x 2 1/2" lg + nylon locknut & flat washer .....	4
30	300-36250	Bolt 3/8" NC x 1" lg + lock washer .....	4
31	110-38321	Right spacer .....	1
32	9456-06-06	«T» female 3/8" NPT swivel , female 3/8" NPT .....	2
33	110-26671	Access door for lower extension .....	1
34	110-26651	Lower extension .....	1
35	9406-04-04	Elbow 90 degrees 1/4" NPT swivel .....	2
36	110-29102	Hexagonal extension .....	1
37	15 PC 32G	Cylinder 1 1/2" x 32" stroke .....	1
38	15 PC 32D	Cylinder 1 1/2" x 32" stroke .....	1
39	190-08231	Hose 1/4" SAE 100R2AT - 500 PSI x 69 1/2" lg .....	2
40	190-08241	Hose 1/4" SAE 100R2AT - 500 PSI x 26 1/2" lg .....	2
41	TSB-4864	Hoses support for deflector cylinder .....	opt.
42	25TR08	Cylinder .....	opt.
43	6004	Clevis pin 1" x 3 1/8"(4) .....	opt.
44	Std.	Hairpin cotter 7/8" (4) .....	opt.
45	TSB-74104-IND	Hoses support on chute base .....	opt.
46	110-44331	Sprocket 9 teeth .....	1
47	130-08152	"Orbit" motor support .....	1
48	336-38000	Nut 7/16" NC .....	4
49	323-36160	Hexagonal socket set screw 3/8" NC x 3/8" lg .....	2
50	150-12731	Flat washer 1/2" heavy-duty .....	16
51	150-12741	Flat washer 7/16" heavy-duty .....	4
52	110-38322	Left spacer .....	1
53	RSP-1/16x10 ORB	Kit of two unidirectional restrictors 10 ORB .....	1
54	150-13181	Pin .....	2
55	RSP-1/16x06 NPT	Kit of two unidirectional restrictors 3/8" NPT .....	opt.
55	RSP-1/16x08 NPT	Kit of two unidirectional restrictors 1/2" NPT .....	opt.
56	140-25231	Support for transport in folded position .....	1

# HYDRAULIC TELESCOPIC CHUTE PCTC-INDR

170-05401

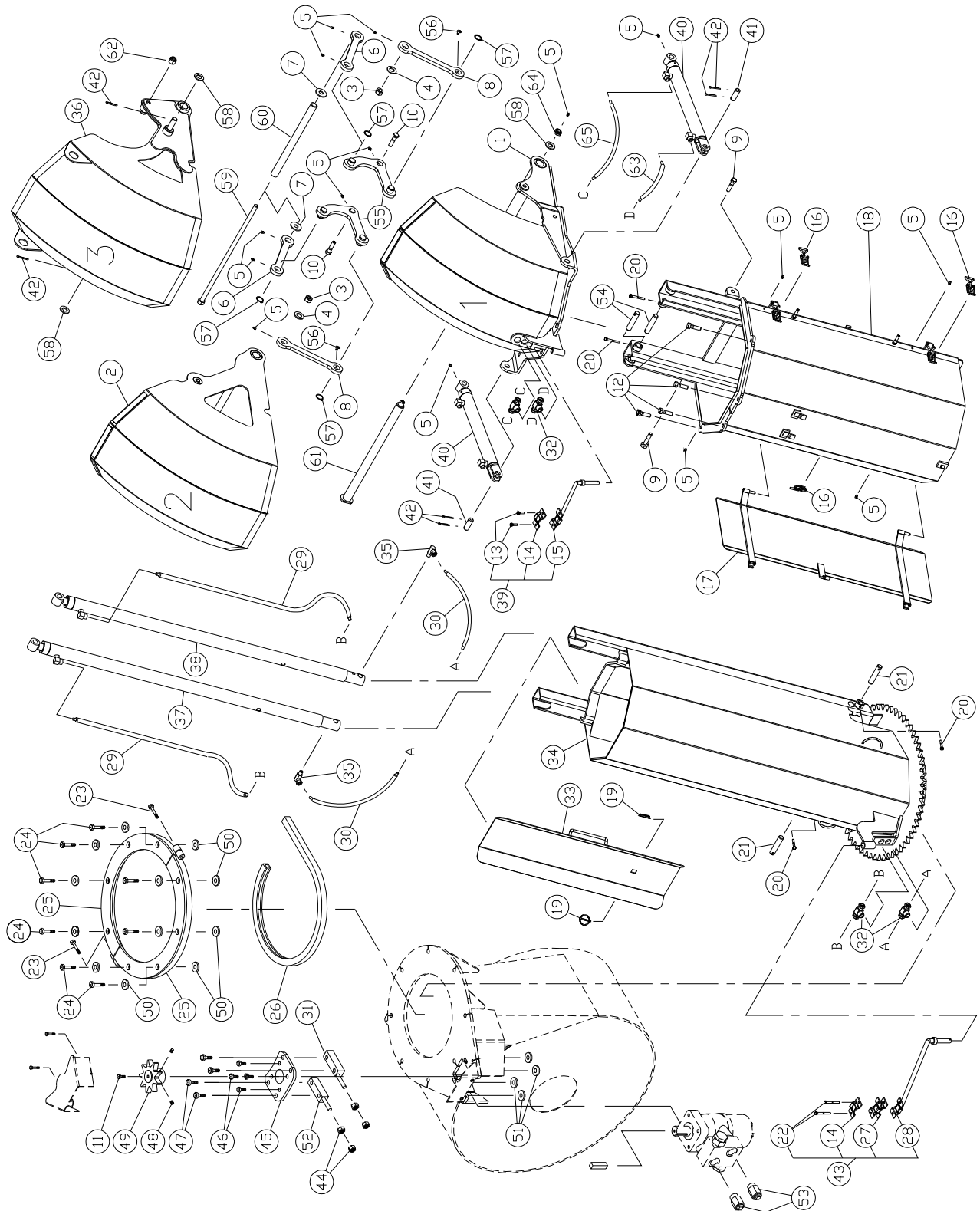

# **HYDRAULIC TELESCOPIC CHUTE PCTC-INDR (cont'd)**

REF.	PART #	DESCRIPTION	QTY
1	110-43233	Stationary deflector .....	1
2	110-43203	Intermediate deflector .....	1
3	346-36000	Nylon locknut 3/8" .....	2
4	378-36500	Flat washer 3/8" i.d. x 1 1/2" o.d. ....	2
5	Std.	Grease fitting 1/4"-28 straight .....	15
6	130-84931	Lever for terminal deflector .....	2
7	376-43000	Flat washer 5/8" i.d. x 1 1/2" o.d. ....	2
8	130-84942	Lever for intermediate deflector .....	2
9	300-40340	Bolt 1/2" NC x 2" lg + nylon locknut .....	2
10	300-40380	Bolt 1/2" NC x 2" lg + flat washer + nylon locknut .....	2
11	300-32220	Bolt 1/4" NC x 3/4" lg + lockwasher .....	1
12	300-40325	Bolt 1/2" NC x 1 3/4" lg + nylon locknut .....	4
13	300-32250	Bolt 1/4" NC x 1" lg + nylon locknut .....	2
14	140-13071	Hoses mounting plate .....	2
15	110-01122	Mounting support plate for upper extension .....	1
16	8376	Adjustable clamp fastener .....	3
17	110-29391	Access panel for upper extension .....	1
18	110-39152	Upper extension .....	1
19	Std.	Lynch pin 3/16" x 1 1/4" .....	2
20	300-32325	Bolt 1/4" NC x 1 3/4" lg + nylon locknut .....	4
21	150-12701	Clevis pin .....	2
22	300-32370	Bolt 1/4" NC x 2 1/2" lg + nylon locknut .....	2
23	300-38400	Bolt 7/16" NC x 3" lg + nylon locknut .....	2
24	300-40415	Bolt 1/2" NC x 3 1/4" lg + nylon locknut .....	8
25	110-12351	Retaining bracket .....	2
26	190-03381	U-shaped UHMW + - 16" i.d. ....	1
27	110-20611	Hoses mounting plate .....	1
28	110-04982	Mounting support plate for lower extension .....	1
29	190-08231	Hose 1/4" x 67 1/4" lg + 1 fitting 4U104 + 1 4U106 .....	2
30	190-08241	Hose 1/4" x 24 1/4" lg + 1 fitting 4U104 + 1 4U106 .....	2
31	110-38321	Spacer .....	1
32	9456-06-06	«T» female 3/8" NPT swivel , female 3/8" NPT .....	4
33	110-26671	Access door for lower extension .....	1
34	110-39001	Lower extension .....	1
35	9406-04-04	Elbow 90 degress 1/4" NPT swivel .....	2
36	110-43193	Terminal deflector .....	1
37	15PC32G	Cylinder 1 1/2" x 32" stroke .....	1
38	15PC32D	Cylinder 1 1/2" x 32" stroke .....	1
39	TSB-4864	Hoses support for deflector cylinder .....	1
40	15L12	Cylinder 1 1/2" x 12" stroke .....	2
41	150-14101	Clevis pin 3/4" x 2 1/8" lg .....	2
42	Std.	Cotter pin 3/16" x 1 1/4" .....	6
43	TSB-74104-IND	Hoses support on chute base .....	1
44	336-38000	Nut 7/16" NC .....	4
45	130-08152	"Orbit" motor support .....	1
46	300-36250	Bolt 3/8" NC x 1" lg + lock washer .....	4
47	300-38385	Bolt 7/16" NC x 2 3/4" lg + nylon locknut .....	4
48	323-36160	Hexagonal socket set screw 3/8" NC x 3/8" lg .....	2
49	110-44331	Sprocket 9 tooth .....	1
50	150-12731	Flat washer 1/2" heavy duty .....	16
51	150-12741	Flat washer 7/16" heavy duty .....	4
52	110-38322	Spacer .....	1
53	RSP-1/16x10 ORB	Kit of two unidirectional restrictors .....	1
54	150-13181	Clevis pin .....	2
55	110-45643	Central lever pivot .....	2
56	std.	Grease fitting elbow 90 degrees 1/4-28 .....	2



## ***HYDRAULIC TELESCOPIC CHUTE PCTC-INDR (cont'd)***

REF.	PART #	DESCRIPTION	QTY
57	Std.	Retaining ring - external 1" .....	4
58	376-46310	Flat washer 3/4" d.i. x 1 1/2" d.e. ....	3
59	110-45661	Threaded rod 5/8"-11 NC x 20 1/4" lg + nut 5/8" (welded).....	1
60	150-14921	Spacer 14 29/32" lg .....	1
61	110-43221	Pin for main pivot.....	1
62	346-44000	Nylon nut 5/8" NC .....	1
63	190-13231	Hose 1/4" x 15 1/2" lg + 1 fitting 4U104 + 1 fitting 4U106 .....	2
64	346-47000	Nylon nut thin 3/4" NC .....	1
65	190-13241	Hose 1/4" x 28 1/2" lg + 1 fitting 4U104 + 1 fitting 4U106 .....	2

# OPTIONS

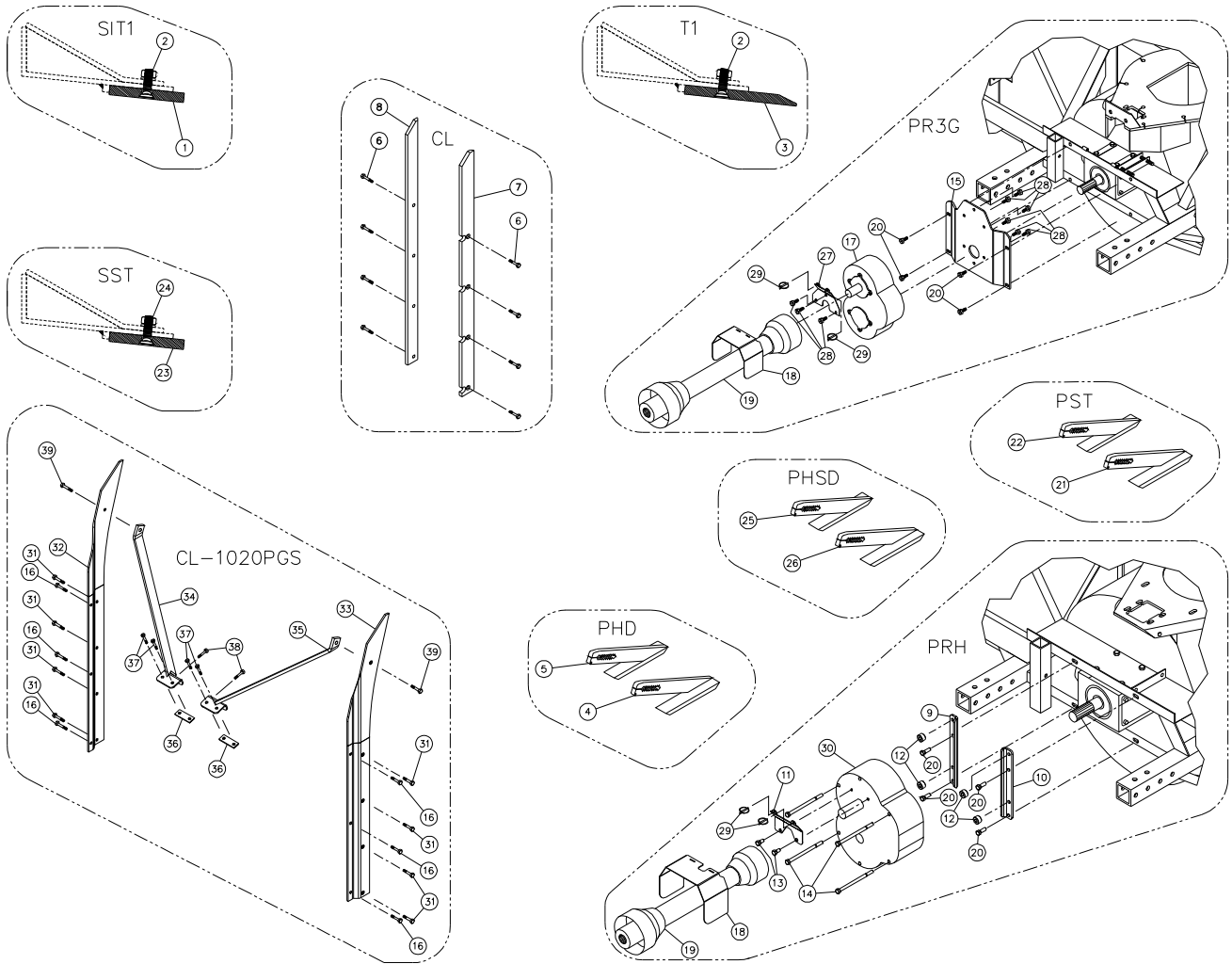

REF.	PART #	DESCRIPTION	QTY
1	140-21631	Scraper blade (hardened steel, not sharpened, reversible) 1/2" x 4" x 95" .....	1
2	Std.	Plow bolt 7/16" NC x 1 3/4" lg + nut & lockwasher .....	10
3	140-21641	Scraper blade (hardened steel, sharpened, not reversible) 1/2" x 6" x 95" .....	1
4	110-44212	Carbon steel skid shoe (right side) .....	1
5	110-44211	Carbon steel skid shoe (left side) .....	1
6	Std.	Plow bolt 7/16" NC x 1 1/2" lg + nut & lockwasher .....	8
7	130-08311	Lateral blade (right side) 58" lg .....	1

## OPTIONS (cont'd)

REF.	PART #	DESCRIPTION	QTY
8	130-19281	Lateral blade (left side) 58" lg.....	1
9	130-84911	Mounting plate for speed reducer (left side) .....	1
10	130-84912	Mounting plate for speed reducer (right side).....	1
11	130-84951	Guard mounting plate .....	1
12	150-14941	Spacer 1 1/4" dia. x 3/4" lg.....	4
13	300-40250	Bolt 1/2" NCx 1" lg+ lock washer .....	2
14	300-40700	Bolt 1/2" NCx 8" lg+ nylon locknut .....	4
15	130-70641	Mounting plate for speed reducer 1000 @555, with gears 200 HP.....	1
16	300-40310	Bolt 1/2" NCx 1 1/2" lg+ nylon locknut .....	6
17	9721	Speed reducer 1000 @555 with gears 200 HP .....	1
18	130-67491	PTO shroud for reduction gear box, with gears 200 HP .....	1
19	9475-1	P.T.O T90, QD 1 3/8"-21, SBI 1 3/4"-20 .....	your choice
19	9475-2	P.T.O T90, QD 1 3/4"-20, SBI 1 3/4"-20 .....	your choice
20	300-40310	Bolt 1/2" NCx 1 1/2" lg+ flat washer + nylon locknut .....	4
21	110-44262	Stainless steel skid shoe (right side).....	1
22	110-44261	Stainless steel skid shoe (right side).....	1
23	140-21681	Scraper blade (stainless steel, not sharpened, reversible) 1/2" x 4" x 95" lg .....	1
24	Std.	Flow bolt 7/16" NCx 1 3/4" lg+ nut & lock washer .....	10
24	333-40340	Bolt cyl. head 6 FC 1/2" NCx 2" lg (stainless)+ nut & lock washer .....	opt.
25	110-45781	Skid shoe (left side) with rocktec sole.....	1
26	110-45782	Skid shoe (right side) with rocktec sole.....	1
27	130-76211	Mounting plate for PTO shroud for reduction gear box 200 HP .....	1
28	300-40280	Bolt 1/2" NCx 1 1/4" lg+ lock washer .....	9
29	Std.	Lynch pin 1/4" X 1 3/4" .....	2
30	9769	Reduction gear box 1000 @555, 3 gears FRH-30M-2 .....	1
31	319-38280	Flow bolt 7/16" NCx 1 1/4" lg+ nut & lock washer .....	8
32	110-46001	Lateral blade (left side) 78" lg.....	1
33	110-46031	Lateral blade (right side) 78" lg.....	1
34	110-46021	Left lateral blade strengthener .....	1
35	110-46041	Right lateral blade strengthener .....	1
36	140-26061	Frame strengthener .....	2
37	300-40310	Bolt 1/2" x 1 1/2" lg+ nylon locknut .....	4
38	300-40280	Bolt 1/2" x 1 1/4" lg+ nylon locknut .....	2
39	319-38280	Flow bolt 7/16" NCx 1 3/4" lg+ nut & lock washer .....	2

# P.T.O. SHAFT # 9475, 9475-1 & 9475-2 (T90)

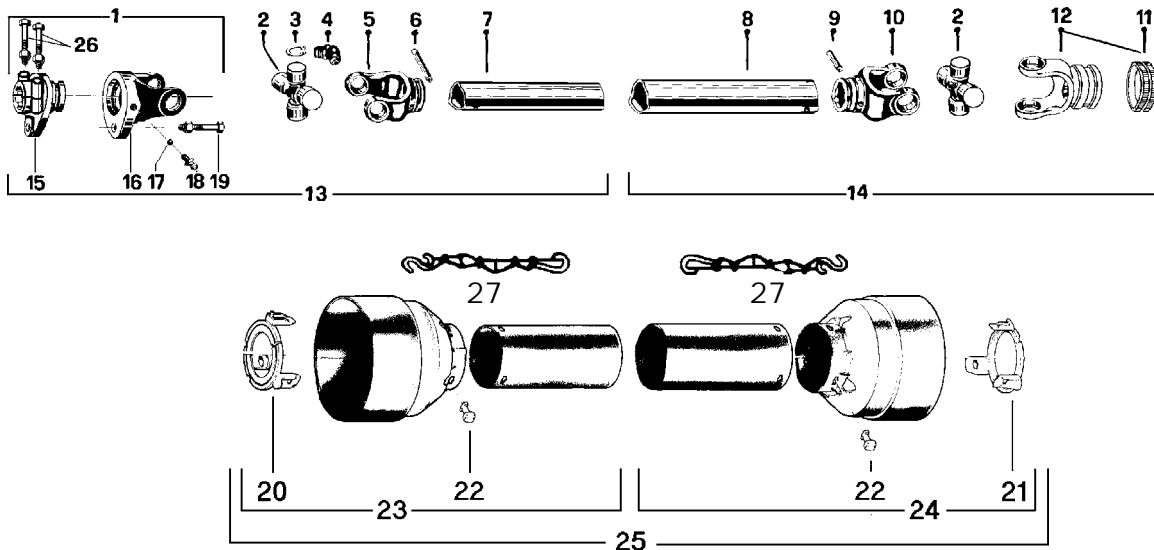

REF.	PART #	DESCRIPTION	QTY		
			9475	9475-1	9475-2
1	9476	Safety shear yoke (2 bolts) 1 3/4" - 20 splines .....	1	1	1
2	9477	U-joint + 4 retaining rings + 1 grease fitting .....	2	2	2
3	9478	Retaining ring .....	8	8	8
4	8110	Grease fitting .....	2	2	2
5	9479	Yoke for inner tube .....	1	1	1
6	9210	Stopper for tube .....	1	1	1
7	9212	Inner tube .....	1	1	1
8	9211	Outer tube .....	1	1	1
9	9210	Stopper for tube .....	1	1	1
10	9480	Yoke for outer tube .....	1	1	1
11	8363	Collar kit .....	1	1	-
11	8364	Collar kit .....	-	-	1
12	9481	Yoke with hole 1 3/8"-6 splines + yoke stopper .....	1	-	-
12	9482	Yoke with hole 1 3/8"-21 splines + yoke stopper .....	-	1	-
12	9483	Yoke with hole 1 3/4"-20 splines + yoke stopper .....	-	-	1
13	9484	P.T.O. section, SBI 1 3/4"-20, inner part, with protector .....	1	1	1
14	9485	P.T.O. section, QD 1 3/8"-6, outer part, with protector .....	1	-	-
14	9485-1	P.T.O. section, QD 1 3/8"-21, outer part, with protector .....	-	1	-
14	9485-2	P.T.O. section, QD 1 3/4"-20, outer part, with protector .....	-	-	1
15	9486	Adaptor 1 3/4"-20 splines (2 bolts) .....	1	1	1
16	9487	Yoke and shearplate .....	1	1	1
17	9205	Ball .....	24	24	24
18	8071	Grease fitting .....	1	1	1
19	9207	Safety shear bolt grade 10.9 M12 x 65 mm .....	1	-	-
19	9207-375	Safety shear bolt grade 8.8 M12 x 65 mm (reduced to 10 mm at the point of rupture) ....	-	1	1
20	9459	Bearing ring for inner guard tube .....	1	1	1
21	9460	Bearing ring for outer guard tube .....	1	1	1
22	8109	Stopper .....	6	6	6
23	9221	Inner shield .....	1	1	1
24	9220	Outer shield .....	1	1	1
25	9222	Complete shield .....	1	1	1
26	9662	Bolt M16 x 80 mm + lock nut .....	2	2	2
27	8308	Safety chain .....	2	2	2

# P.T.O. SHAFT # 9598, 9599 & 9604 (V90)

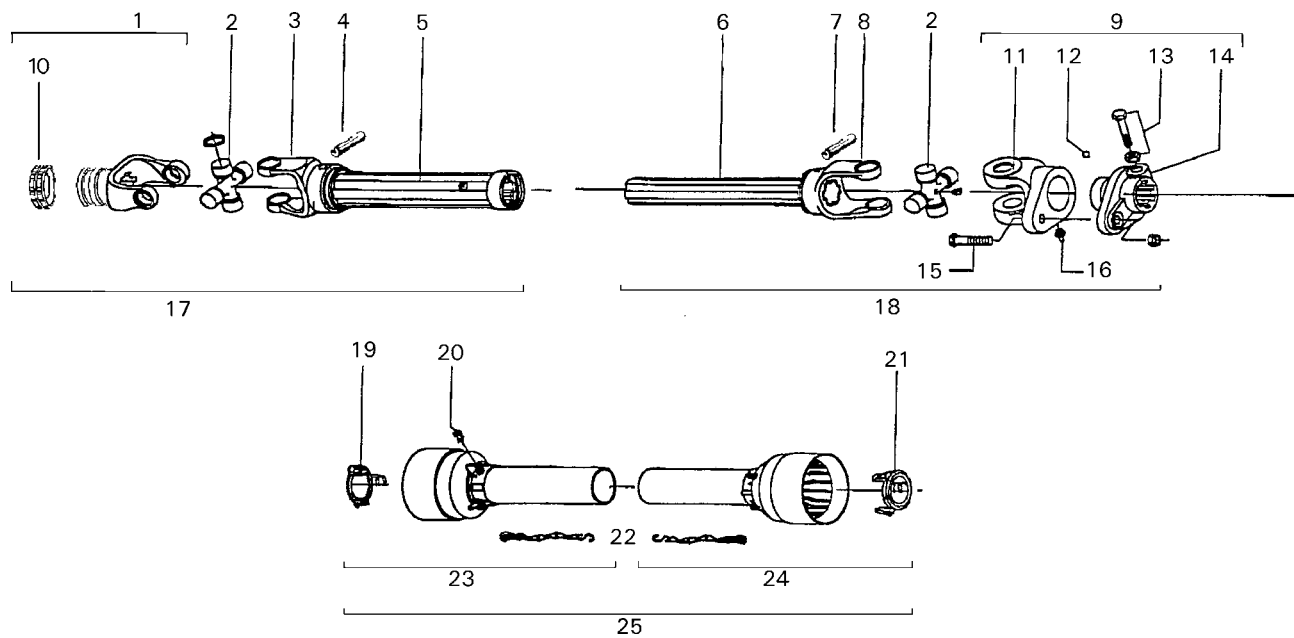

REF.	PART #	DESCRIPTION	QTY		
			9598	9599	9604
1	9481	Yoke with hole 1 3/8" - 6 splines with lock yoke (540 RPM) .....	1	-	-
1	9482	Yoke with hole 1 3/8" - 21 splines with lock yoke (1000 RPM).....	-	1	-
1	9483	Yoke with hole 1 3/4" - 20 splines with lock yoke (1000 RPM).....	-	-	1
2	9477	U-joint .....	2	2	2
3	9600	Yoke for outer tube .....	1	1	1
4	9210	Stopper for tube .....	1	1	1
5	9601	Outer tube .....	1	1	1
6	9602	Inner tube .....	1	1	1
7	9210	Stopper for tube .....	1	1	1
8	9603	Yoke for inner tube .....	1	1	1
9	9476	Safety shear yoke .....	1	1	1
10	8363	collar kit .....	1	1	-
10	8364	collar kit .....	-	-	1
11	9487	Yoke and shearplate M12 x 65 .....	1	1	1
12	9205	Ball 5/16" dia. ....	24	24	24
13	9461	Bolt + nut M12x1.25x75 .....	2	2	2
14	9486	Adaptor .....	1	1	1
15	9207	Safety shear bolt grade 10.9 M12 x 65 mm + nut .....	1	1	1
16	8071	Grease fitting .....	1	1	1
17	9607	P.T.O. section, outer part, without protector, 1 3/8" - 6 splines .....	1	-	-
17	9607-1	P.T.O. section, outer part, without protector, 1 3/8" - 21 splines .....	-	1	-
17	9607-2	P.T.O. section, outer part, without protector, 1 3/4" - 20 splines .....	-	-	1
18	9608	P.T.O. section, inner part, without protector .....	1	1	1
19	9460	Bearing ring .....	1	1	1
20	8109	Stopper .....	6	6	6
21	9459	Bearing ring .....	1	1	1
22	8308	Safety chain .....	2	2	2
23	9220	Outer shield .....	1	1	1
24	9221	Inner shield .....	1	1	1
25	9222	Complete shield .....	1	1	1

# GEAR BOX # 9307 (T279)

170-05031.tif

Oil volume required: 1.64 liters  
Use SAE 80W90 oil or equivalent.

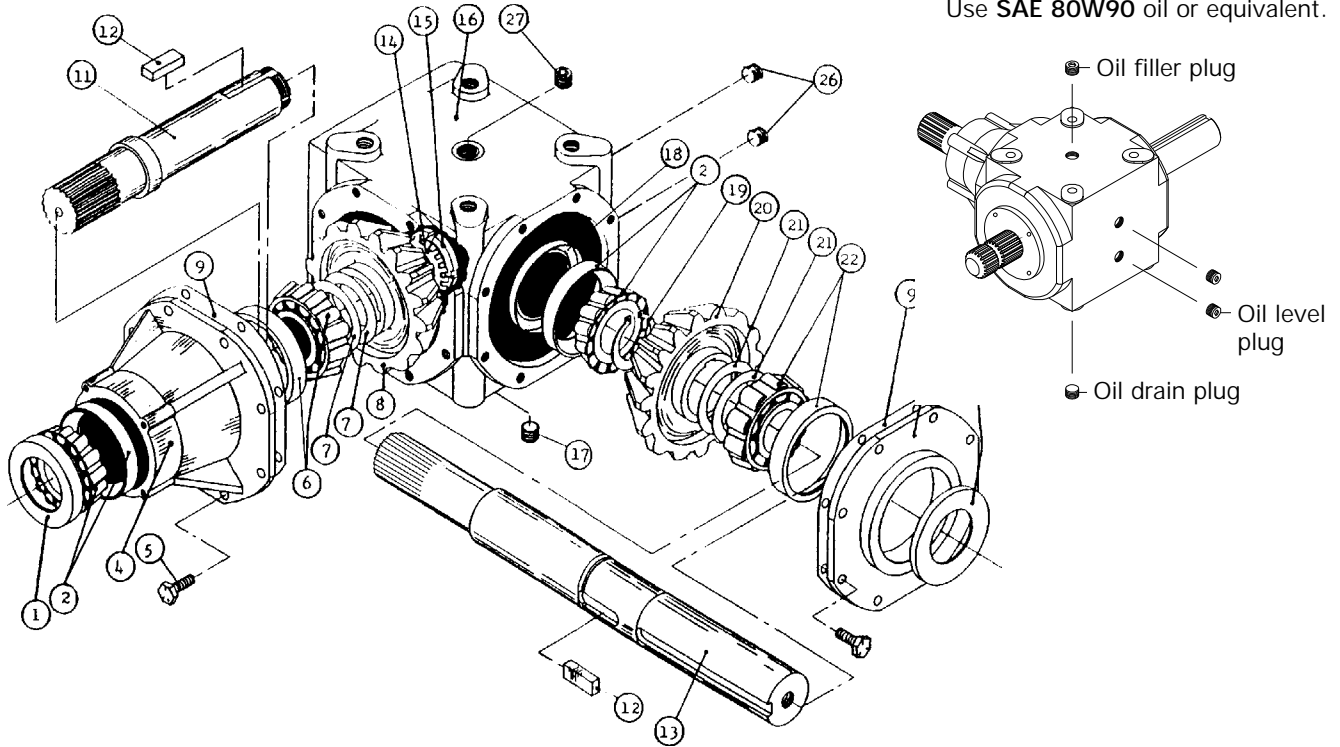

REF.	PART #	DESCRIPTION	QTY
1	6314	Oil seal 52 x 85 x 10 .....	1
2	30209-A	Bearing: cone & cup .....	2
4	6318	Extension .....	1
5	6319	Bolt M10 x 22 .....	16
6	32209-A	Bearing: cone & cup .....	1
7	6321	Shim .....	2
8	6322	Gear Z21 .....	1
9	- - -	Use silicone caulking .....	-
11	6325	Side shaft Z20 (1¾" - 20 splines) .....	1
12	6326	Key B14 x 9 x 40 .....	2
13	9345	Impeller shaft (2" & 1¾" - 20 splines) .....	1
14	6328	Spring washer .....	1
15	6329	Lock nut M40 x 1.5 H9 .....	1
16	6330	Casing .....	1
17	6331	Plug 3/8" gas (drain plug) .....	1
18	6332	Oil seal 45 x 72 x 8 .....	1
19	6333	External circlip 50 UNI7435 .....	1
20	6334	Gear Z21 .....	1
21	6335	Shim .....	2
22	30210-A	Bearing: cone & cup .....	1
24	6338	Cover .....	1
25	6339	Oil seal 50 x 72 x 8 .....	1
26	6331	Plug 3/8" gas (oil level) .....	2
27	6331	Plug 3/8" gas (oil filling) .....	1

# REDUCTION GEAR BOX # 9769 PRH-30M-2

Oil volume required: 1.2 liters  
Use XLEP-68/320 oil or equivalent.

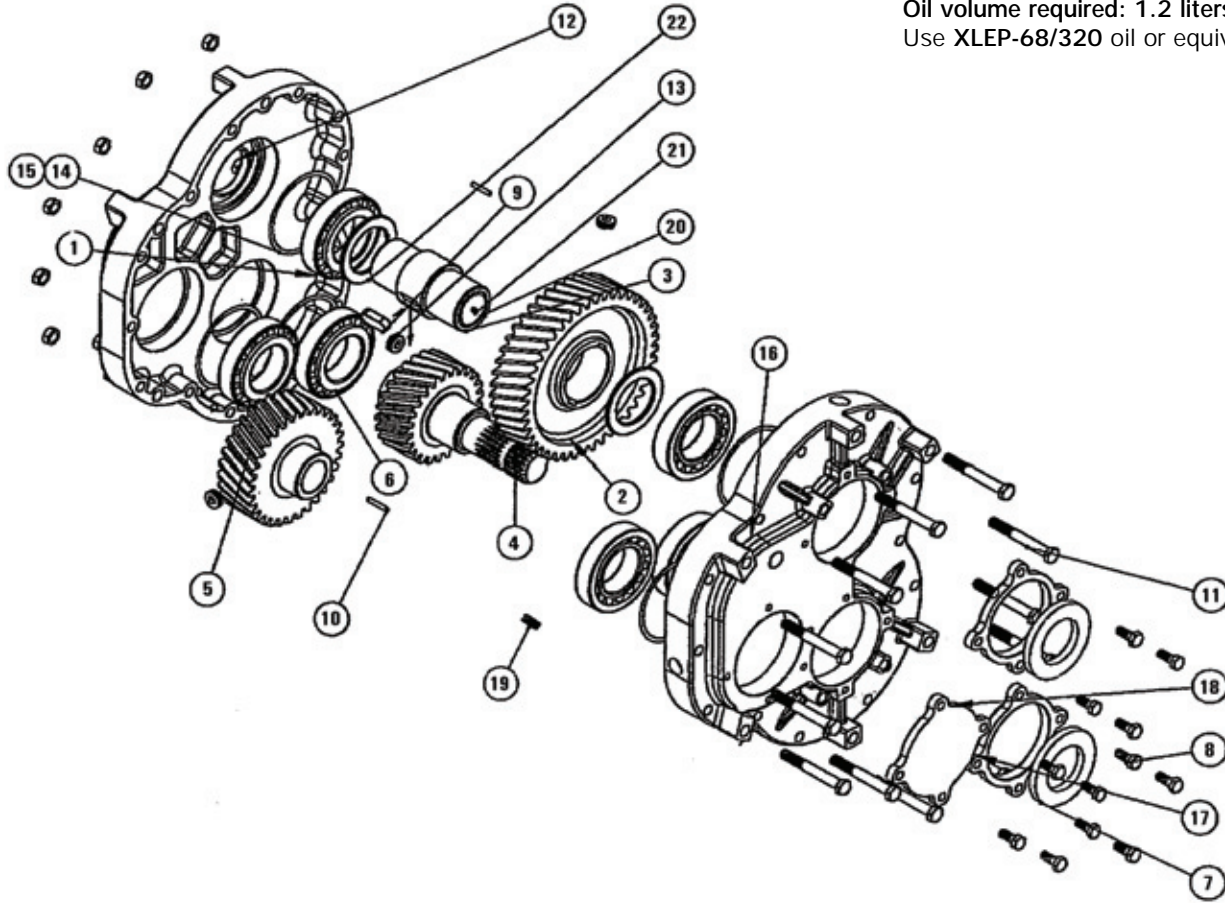

REF.	#PART	DESCRIPTION	QTY
1	9770	Half casing .....	1
2	9771	Gear .....	2
3	9772	Splined adaptor 1 3/4" - 20 .....	1
4	9773	Input shaft with gear .....	1
5	9774	Gear .....	1
6	NTN4T-32212U	Tapered roller-bearing .....	6
7	9775	Oil seal 60 mm x 100 x 10 .....	3
8	Std.	Bolt M10 x 25 .....	12
9	9776	Key M6 x 10 x 40 .....	2
10	9777	Pin .....	2
11	Std.	Bolt M12 x 95 .....	11
12	Std.	Nut M12 .....	11
13	9778	Plug .....	1
14	9779	Shim .....	12
15	9780	Shim .....	12
16	9781	Half casing .....	1
17	9782	Hollow cap .....	2
18	9783	Solid cap .....	1
19	9784	Plug .....	6
20	9785	Cover .....	1
21	Std.	Grease fitting .....	1
22	9786	Spacer .....	1

# SPEED REDUCER # 9721 - 200 HP PR3G-200-2

Oil volume required: 0.9 liters  
Use XLEP-68/320 oil or equivalent.

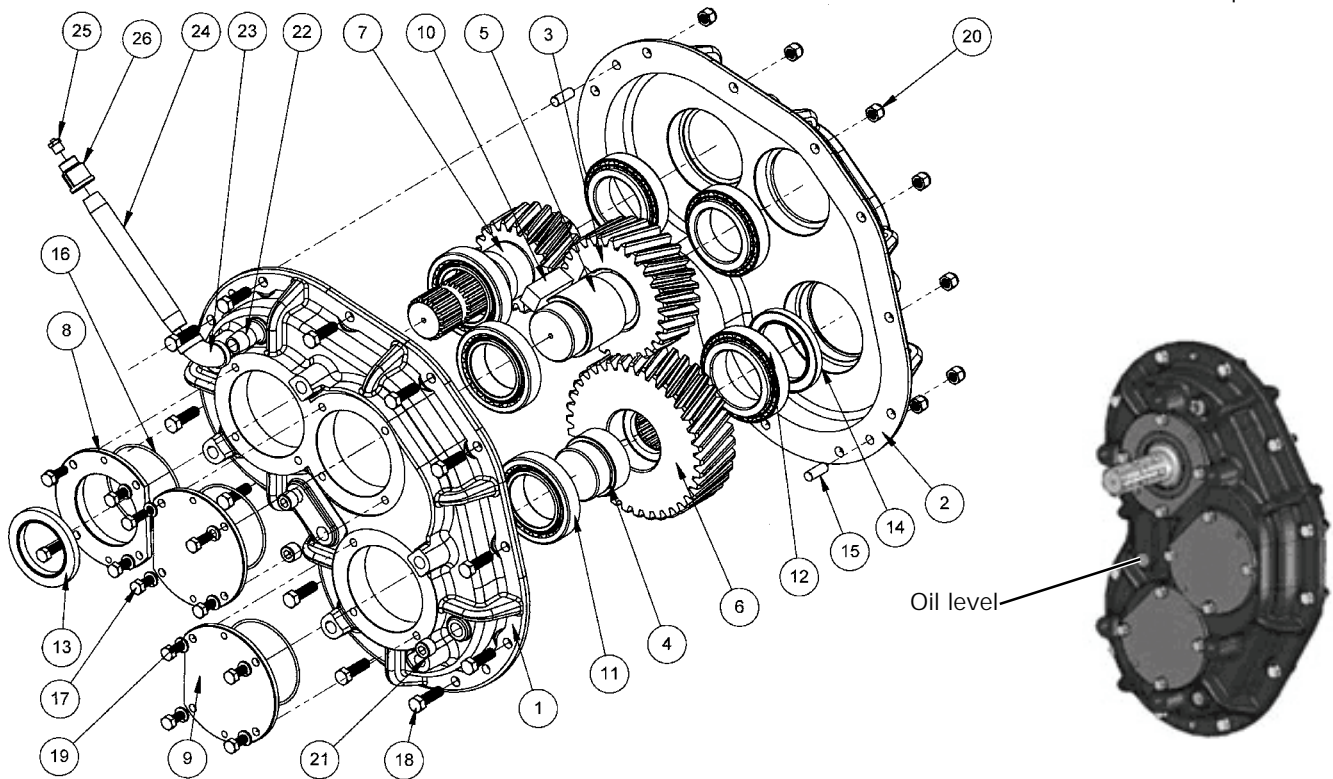

REF.	PART #	DESCRIPTION	QTY
1	9752	Half casing .....	1
2	8753	Half casing .....	1
3	9754	Helical gear with the teeth inclined to the right (28 teeth) .....	1
4	9756	Adaptor .....	1
5	9755	Intermediate shaft .....	1
6	9757	Helical gear with the teeth inclined to the left (36 teeth) .....	1
7	9758	Shaft with helical gear with the teeth inclined to the left (20 teeth) .....	1
8	9759	Open cover .....	1
9	9760	Closed over .....	2
10	9761	Square key 0.750 x 2.000 .....	1
11	9762	Metric taper roller bearing with cup .....	5
12	9763	Metric taper roller bearing with cup .....	1
13	9764	Oil seal .....	1
14	9765	Oil seal .....	1
15	9766	Goupille 3/8" x 1" .....	2
16	9767	Metric oil seal .....	3
17	300-34235	Bolt 5/16" NC x 7/8" lg .....	12
18	300-36280	Bolt 3/8" x 1 1/4" lg .....	12
19	371-34000	lock washer 5/16" .....	12
20	346-36000	Nylon locknut 3/8" .....	12
21	9706	Plug 3/8" NPT .....	3
22	9707	Pipe 3/8" x 1.5 .....	1
23	9708	Elbow 3/8" 90 deg. ....	1
24	9709	Pipe 3/8" x 6 .....	1
25	9710	Vent plug 1/8" 5 PSI .....	1
26	9711	Adaptor 3/8" - 1/8" NPT .....	1



# CYLINDER 25TR08

15050

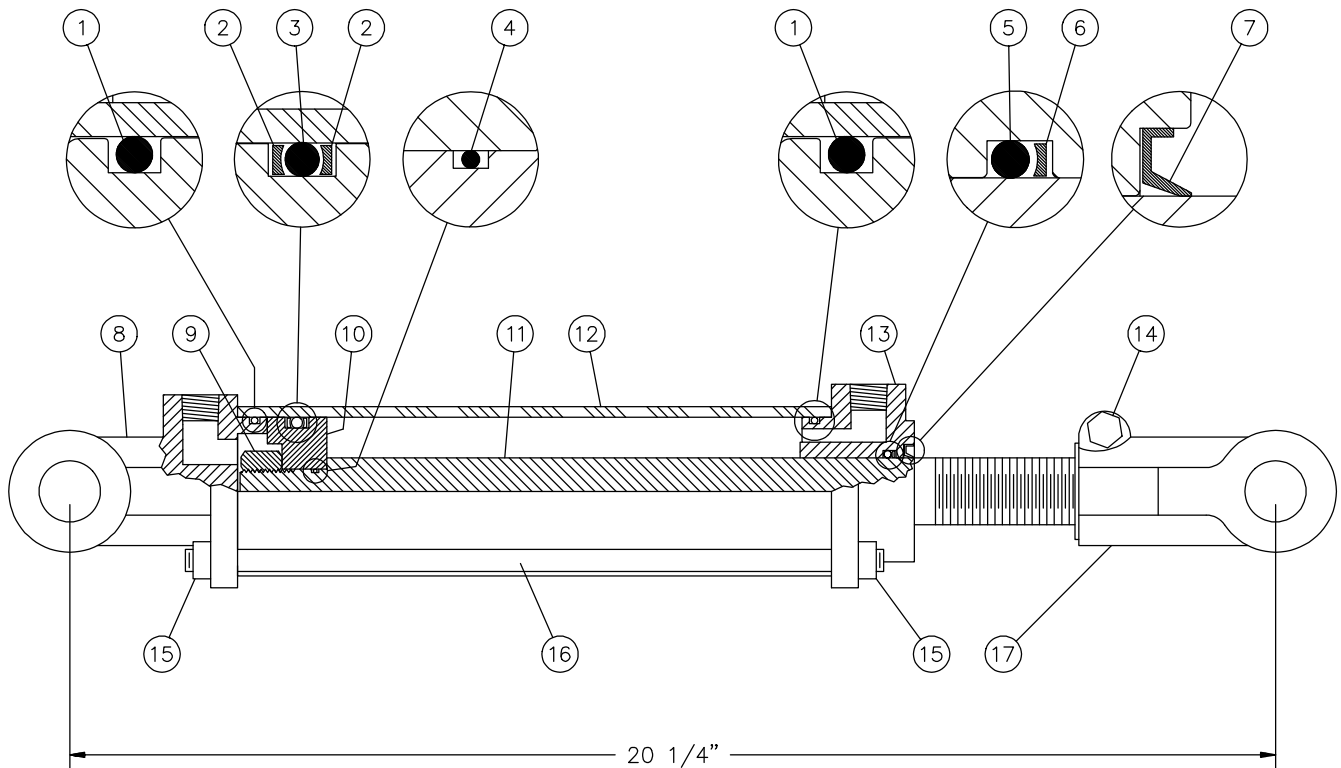

REF.	PART #	DESCRIPTION	QTY
1	See #RK25TR	O-ring 1/8" x 2 1/4" x 2 1/2" .....	2
2	See #RK25TR	Back-up 2 1/2" o.d. x 3/16 ø .....	2
3	See #RK25TR	O-ring 3/16" x 2 1/8" x 2 1/2" .....	1
4	See #RK25TR	O-ring 1/16" x 5/8" x 3/4" .....	1
5	See #RK25TR	O-ring 1/8" x 1 1/8" x 1 3/8" .....	1
6	See #RK25TR	Back-up 1 3/8" o.d. x 1/8" ø .....	1
7	See #RK25TR	Wiper 1 1/8" i.d. x 1 5/8" o.d. ....	1
8	492401	Yoke (for 2 1/2" tube) .....	1
9	339-46000	Nut 3/4" NF .....	1
10	4924-31	Piston 2 1/2" ø .....	1
11	491980	Piston rod 1 1/8" .....	1
12	491668	Cylinder body 2 1/2" ø .....	1
13	492421	Head (for 2 1/2" tube) .....	1
14	301-36355	Bolt 3/8" NC x 2 1/4" lg + nut .....	1
15	377-36000	Nut 3/8" NC .....	8
16	Std.	Threaded rod 3/8" NC x 12" lg .....	4
17	458599	Yoke (for 1 1/8" rod) .....	1
NI*	8183	Pin 1" ø + cotter pin .....	2
NI*	RK25TR	Repair kit for cylinder 2 1/2" (includes # 1, 2, 3, 4, 5, 6, & 7) .....	1

\*NI = NOT ILLUSTRATED

# CYLINDER 15PC32

170-04361

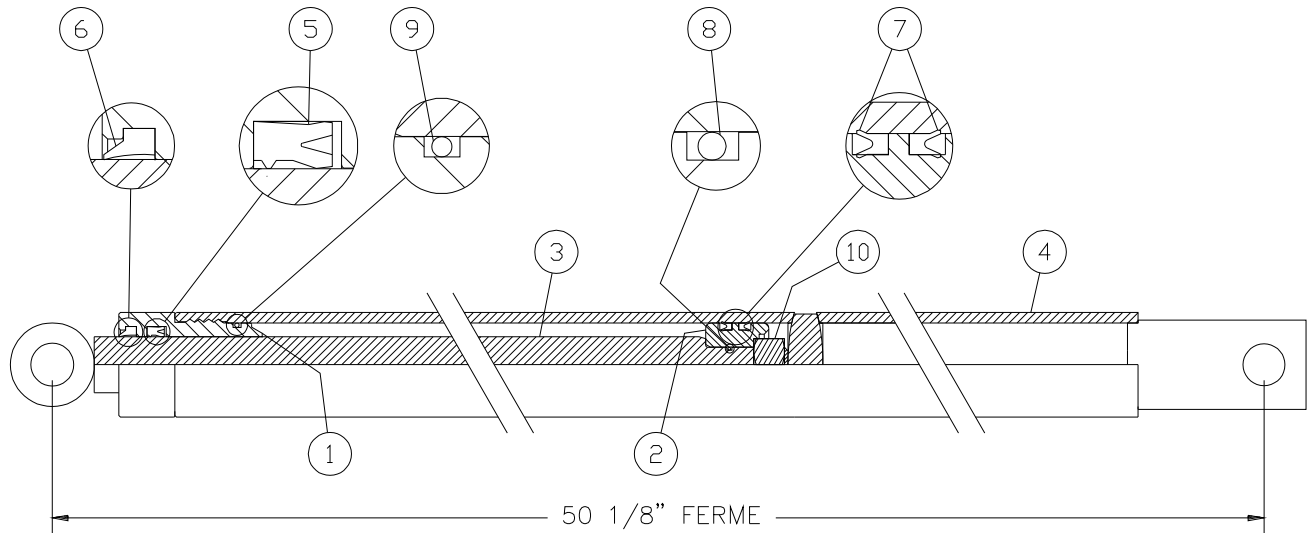

REF.	PART #	DESCRIPTION	QTY	
			15PC32D	15PC32G
1	150-06561	Head 1 1/2" dia. ....	1	1
2	150-06571	Piston 1 1/2" dia. ....	1	1
3	110-26561	Piston rod 1" dia. ....	1	1
4	110-29631	Cylinder body 1 1/2" dia. (15PC32D) .....	1	-
4	110-29632	Cylinder body 1 1/2" dia. (15PC32G) .....	-	1
5	DRTV-18-1.00-31	«U» seal 3/16" x 1" x 1 3/8" .....	1	1
6	ST-100	Wiper 3/16" x 1" x 1 1/8" .....	1	1
7	DSV12-1.25-18	«U» seal 3/16" x 1 1/4" x 1 1/2" .....	2	2
8	OR-014	O-ring 1/16" x 1/2" x 5/8" .....	1	1
9	OR-125	O-ring 3/32" x 1 5/16" x 1 1/2" .....	1	1
10	336-44000	Nut 5/8" NC .....	1	1
NI*	9689	Repair kit (includes # 5, 6, 7, 8 & 9) .....	1	1

\*NI = NOT ILLUSTRATED

10

# DEFLECTOR CYLINDER 15L12

170-05801

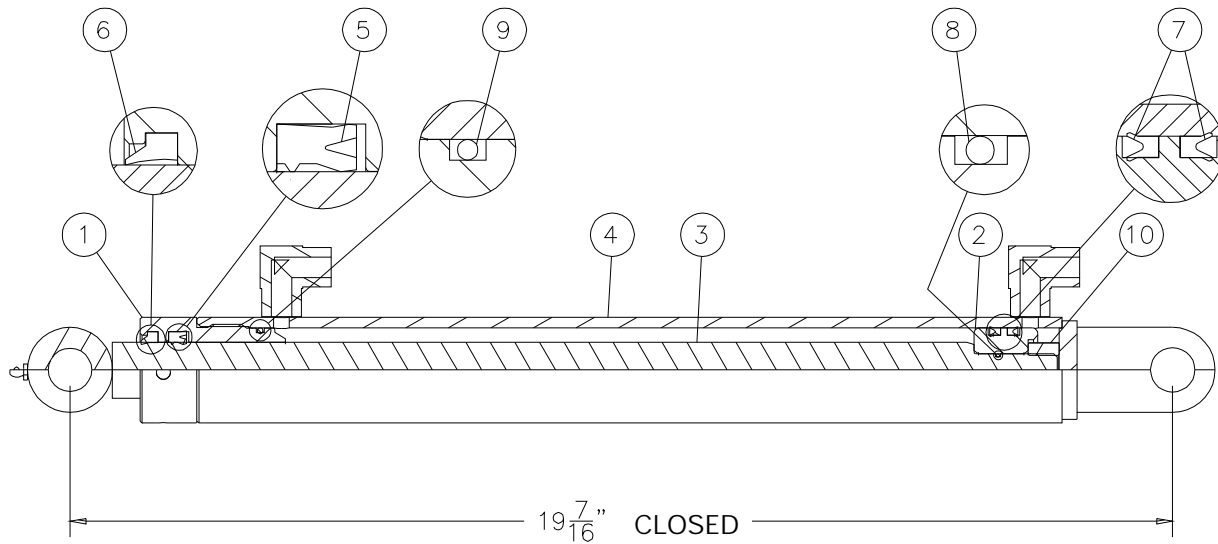

REF.	PART #	DESCRIPTION	QTY
1	150-06561	Head 1 1/2" dia. ....	1
2	150-06571	Piston 1 1/2" dia. ....	1
3	110-43122	Piston rod 1" dia. ....	1
4	110-43101	Cylinder body 1 1/2" dia. ....	1
5	DRTU-18-1.00-31	«U» seal 3/16" x 1" x 1 3/8" ....	1
6	ST-100	Wiper 3/16" x 1" x 1 3/8" ....	1
7	DSU12-1.25-18	«U» seal 3/16" x 1 1/4" x 1 1/2" ....	2
8	OR-014	O-ring 1/16" x 1/2" x 5/8" ....	1
9	OR-125	O-ring 3/32" x 1 5/16" x 1 1/2" ....	1
10	336-44000	Nut 5/8" NC ....	1
NI*	9689	Repair kit (includes # 5, 6, 7, 8 & 9) ....	1

\*NI = NOT ILLUSTRATED

# HYDRAULIC MOTOR # MLH-250 & MLH-315

## CUSHION VALVE H110

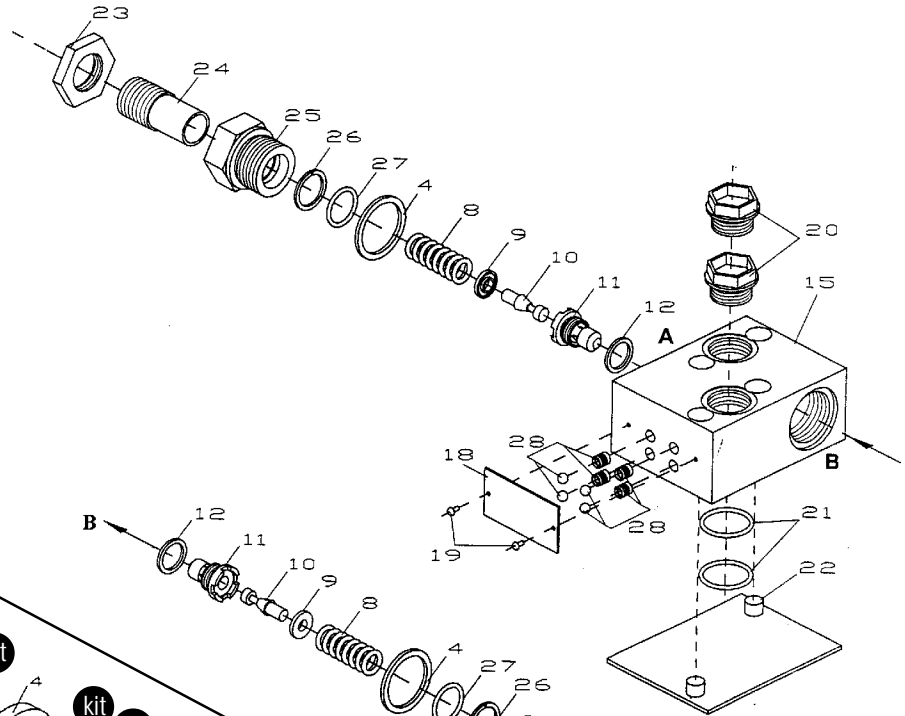

## MOTOR

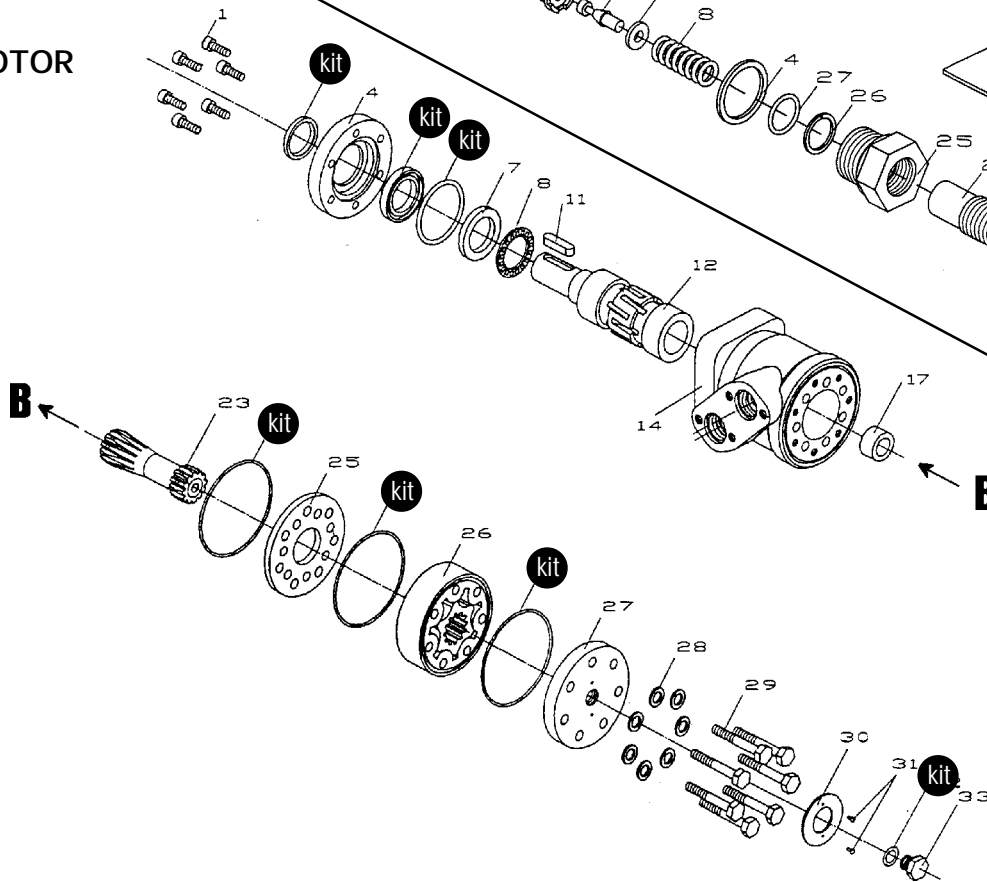







10





REF.	PART #	DESCRIPTION	QTY
kit	8368	Set of seals.....	1
11	8369	Key for "Orbit" motor.....	1

# TORQUE CHART

## TORQUE SPECIFICATION TABLE

Thread UNC and UNF		Grade 2 				Grade 5   				Grade 8*   			
Bolt size		Torque				Torque				Torque			
Inches	mm	Pound feet min.	max.	Newton meters min.	max.	Pound feet min.	max.	Newton meters min.	max.	Pound feet min.	max.	Newton meters min.	max.
1/4	6.35	5	6	6.8	8.13	9	11	12.2	14.9	12	15	16.3	30.3
5/16	7.94	10	12	13.6	16.3	17	20.5	23.1	27.8	24	29	32.5	39.3
3/8	9.53	20	23	27.1	31.2	35	42	47.5	57.0	45	54	61.0	73.2
7/16	11.11	30	35	40.7	47.4	54	64	73.2	86.8	70	84	94.9	113.9
1/2	12.70	45	52	61.0	70.5	80	96	108.5	130.2	110	132	149.2	179.0
9/16	14.29	65	75	88.1	101.6	110	132	149.2	179.0	160	192	217.0	260.4
5/8	15.88	95	105	128.7	142.3	150	180	203.4	244.1	220	264	298.3	358.0
3/4	19.05	150	185	203.3	250.7	270	324	366.1	439.3	380	456	515.3	618.3
7/8	22.23	160	200	216.8	271.0	400	480	542.4	650.9	600	720	813.6	976.3
1	25.40	250	300	338.8	406.5	580	696	786.5	943.8	900	1080	1220.4	1464.5
1 1/8	25.58	-	-	-	-	800	880	1084.8	1193.3	1280	1440	1735.7	1952.6
1 1/4	31.75	-	-	-	-	1120	1240	1518.7	1681.4	1820	2000	2467.9	2712.0
1 3/8	34.93	-	-	-	-	1460	1680	1979.8	2278.1	2380	2720	3227.3	3688.3
1 1/2	38.10	-	-	-	-	1940	2200	2630.6	2983.2	3160	3560	4285.0	4827.4

\* Thick nuts must be used with grade 8 bolts.

Size of screw	Thread	Pitch (mm)	Grade 4T  				Grade 7T 				Grade 8T  			
			Torque				Torque				Torque			
			Pound feet min.	max.	Newton meters min.	max.	Pound feet min.	max.	Newton meters min.	max.	Pound feet min.	max.	Newton meters min.	max.
M6	UNC	1.00	3.6	5.8	4.9	7.9	5.8	9.4	7.9	12.7	7.2	10	9.8	13.6
M8	UNC	1.25	7.2	14	9.8	19	17	22	23	29.8	20	26	27.1	35.2
M10	UNC	1.5	20	25	27.1	33.9	34	40	46.1	54.2	38	46	51.5	62.3
M12	UNC	1.75	28	34	37.9	46.1	51	59	69.1	79.9	57	66	77.2	89.4
M14	UNC	2.0	49	56	66.4	75.9	81	93	109.8	126	96	109	130.1	147.7
M16	UNC	2.0	67	77	90.8	104.3	116	130	157.2	176.2	129	145	174.8	196.5
M18	UNC	2.0	88	100	119.2	136	150	168	203.3	227.6	175	194	237.1	262.9
M20	UNC	2.5	108	130	146.3	176.2	186	205	252	277.8	213	249	288.6	337.4
M8	UNF	1.0	12	17	16.3	23	19	27	25.7	36.6	22	31	29.8	42
M10	UNF	1.25	20	29	27.1	39.3	35	47	47.4	63.7	40	52	54.2	70.5
M12	UNF	1.25	31	41	42	55.6	56	68	75.9	92.1	62	75	84	101.6
M14	UNF	1.5	52	64	70.5	86.7	90	106	122	143.6	107	124	145	168
M16	UNF	1.5	69	83	93.5	112.5	120	138	162.6	187	140	158	189.7	214.1
M18	UNF	1.5	100	117	136	158.5	177	199	239.8	269.6	202	231	273.7	313
M20	UNF	1.5	132	150	178.9	203.3	206	242	279.1	327.9	246	289	333.3	391.6

Use the above torques when special torque is not given.

NOTE: These values apply to fasteners as received from supplier, dry, or when lubricated with normal engine oil. They do not apply if extreme pressure lubricants are used.

---

---

## WARRANTY

---

12

PRONOVOST warrants this product to the initial purchaser for the period of one year from the date of purchase against defects in materials and workmanship.

We will replace or repair defective parts free of charge if they are returned to our plant in St-Tite, Quebec, Canada.

Transportation charges are the responsibility of the customer. This warranty is not transferable.

Hydraulic cylinders and motors are covered by the manufacturer of these items.

The PTO shafts are warranted by the manufacturer and cover **only** defects in material and workmanship, and is conditional to recommended use and installation only.

All PRONOVOST spare parts purchased are covered by a three (3) month warranty.

This warranty becomes void and nul if the equipment is modified, breaks down as the result of an accident, is not operated according to manufacturer's recommendations, damaged by negligence or if maintenance has not been carried out as specified.

Our obligation is limited to the replacement or repair of the defective part. PRONOVOST accepts no responsibility for direct or indirect consequential damages of any kind.



Ce manuel est aussi disponible en français.  
Veuillez téléphoner.



**LES MACHINERIES PRONOVOST INC.**  
260, Haut du Lac Sud (route 159),  
Saint-Tite, Quebec, Canada, G0X 3H0  
Tel.: (418) 365-7551, Fax: (418) 365-7954  
[www.pronovost.qc.ca](http://www.pronovost.qc.ca)