



**OPERATOR'S / PARTS
MANUAL**



Industrial snowblower
Model
P-982TRC-150

VISIT OUR WEBSITE



www.pronovost.qc.ca

Copyright © Les Machineries Pronovost Inc., 2008

All rights reserved.
Printed in Canada.

TABLE OF CONTENTS

Section	Item	Page
1	Introduction	5
2	Safety	6
	General Safety	6
	Safety in operation	6
	Safety with maintenance	7
	Safety in transport	7
	Safety in storage	7
3	Decals	8
	Safety Decals	8
	Maintenance Decals	10
4	Assembly	12
	General assembly	12
5	Start-up	13
	Basic start-up Procedures	13
6	Maintenance	15
7	Storage	17
8	Trouble Shooting	18
9	Specifications	20
10	Parts List	21
	Snowblower P-982TRC-150	21
	Industrial Chute PCG-IND	25
	Hydraulic Telescopic Chute PCT-IND	27
	Semi-industrial Chute PSIG-92104	29
	Hydraulic Telescopic chute PCT-92104	31
	Hydraulic Lateral Blade	33
	Reduction gear box Options	34
	Reduction Gear Box # 9575 - 150 HP	35
	Reduction Gear Box # 9609 - 180 HP	36
	Reduction Gear Box # 9621 - 200 HP	37
	P.T.O. # 9598, 9599, 9604	38
	Gear Box # 9307	39
	Cylinder 25TR08	40
	Cylinder 15PC32	41
	Hydraulic Motor MLH315	42
11	Torque chart	43
12	Warranty	44

INTRODUCTION

CONGRATULATIONS!

Thank you for choosing PRONOVOST. We are confident this equipment will meet your requirements in terms of quality, performance and reliability.

This manual was prepared to assist you in the safe operation of your new Snowblower. It contains important information which will help you achieve excellent returns with your Snowblower for years to come.

Please read this manual completely before operating your Snowblower and keep it for future reference.

Before starting the machine, you or any other person who will be operating the Snowblower must familiarize yourself with the safety recommendations and the operating instructions. Please read carefully and be sure to understand and follow all recommendations and procedures.

In this manual, the right and left sides are identified as shown on Figure 1.

If you require additional information on your Snowblower, please contact your PRONOVOST Dealer.

NOW take a moment to enter the model, serial number and the date of purchase of your Snowblower in the space provided.

When ordering parts from your Dealer, please refer to these numbers for a fast and efficient service. Use PRONOVOST parts for replacement.

The model and serial numbers are on the name plate shown on Fig. 1.

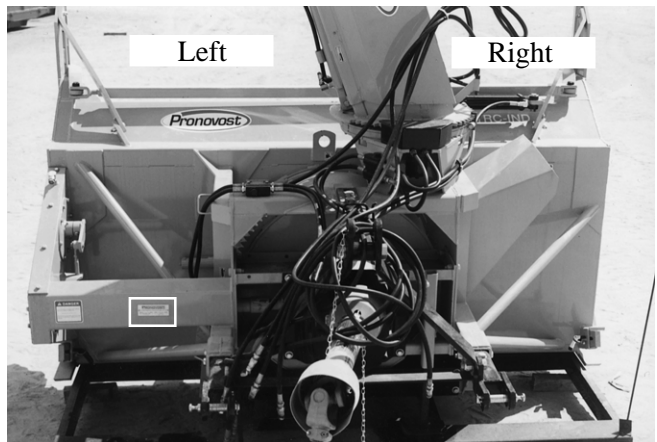

Figure 1

MODEL: _____ ✍

SERIAL NO: _____ ✍

DATE OF PURCHASE: _____ ✍

SAFETY

GENERAL SAFETY

2

WHEN YOU SEE THIS SYMBOL



ATTENTION!

**BE ALERT
YOUR SAFETY IS INVOLVED**

This symbol «SAFETY ALERT» is used in this manual and on the safety decals on the Snowblower. It warns you of the possibility of danger. Carefully read, understand and follow all safety recommendations before operating the Snowblower.

- 1) Careful operation is the best assurance against accidents. Carefully read this manual and follow all recommendations before operating your Snowblower. It is the owner's responsibility to make sure that anyone who will operate the Snowblower will read this manual before operating the equipment.
- 2) Familiarize yourself with all controls and always be ready to stop the Snowblower quickly in case of emergency.
- 3) Never let a child operate the Snowblower.
- 4) Do not modify the Snowblower. Any non authorized modification may affect the efficiency and/or safety of the equipment and will automatically void the warranty.
- 5) Never operate the Snowblower with defective parts or if damaged in any way. Have it repaired before operating.
- 6) Make sure all fasteners are in place and properly secured or tightened. Refer to torque chart on page 43.
- 7) Avoid wearing loose fitting clothing when working with the Snowblower. These could get entangled in moving parts of the equipment and cause accidents.

- 8) Prolonged exposure to noise may hamper hearing. Protect yourself by wearing adequate protection devices.
- 9) Hydraulic fluids under pressure can damage your skin. Do not use your hands to locate a leak.
- 10) Before the beginning of the snow season, inspect all areas where the Snowblower will be used and remove any object which may cause an accident and/or damage the equipment.
- 11) Never operate your Snowblower in poor visibility or without proper lighting conditions.

SAFETY IN OPERATION

- 1) Be sure there are no obstructions around the equipment and that no one stands near the equipment when in operation.
- 2) Do not operate an engine in a confined or non ventilated area.
- 3) Do not perform any adjustments, cleaning, maintenance or repairs with the engine running. The engine must be stopped and the P.T.O. disengaged. Preferably remove the key from the ignition.
- 4) Wear adequate clothing when working in cold or windy conditions.
- 5) Adjust skid shoes for proper ground clearance of scraper blade, especially in rough terrain or soft ground conditions.
- 6) Before operating, make sure the P.T.O. is properly installed and secured.
- 7) Before starting-up the Snowblower, make sure the auger and drum areas are free of ice.
- 8) Put P.T.O. control in neutral position before starting engine.
- 9) Keep hands, feet and clothing away from moving parts of the Snowblower. Stay away from the discharge chute.

SAFETY (cont'd)

- 10) Before unplugging the chute, always disengage the P.T.O., stop the engine and relieve all hydraulic pressures.
- 11) Do not operate in excessive inclined conditions. Be careful when turning in slopes.
- 12) Never operate your Snowblower with missing guards or without protective devices in place.
- 13) Do not operate your Snowblower near buildings, windows or other vehicles without prior and proper adjustment of the chute deflector.
- 14) Never aim discharge chute towards people or animals. This may cause serious injuries.
- 15) Always reduce operating speed in slippery conditions.
- 16) Be careful when backing-up, make sure you have good visibility.
- 17) Always be on the lookout for objects which may enter the snowblower.
- 18) If undue vibrations are felt, disengage the P.T.O., stop the motor and look for the cause of the vibration. Vibration is usually the indication of a problem.
- 19) At the end of the operation, disengage the P.T.O., lower the Snowblower, put transmission in neutral, apply parking brake, stop engine and remove the key from the ignition.

SAFETY WITH MAINTENANCE

- 1) Perform the Snowblower maintenance according to recommendations contained in this manual.

- 2) Stop engine and relieve all hydraulic pressures before doing inspection, maintenance or repairs.
- 3) Never perform any work under the Snowblower while it is supported only by the tractor's hydraulic system. It must be completely supported by wooden blocks or other safe means.

SAFETY IN TRANSPORT

- 1) On public roads, use proper safety lights and check local regulations.
- 2) Be alert while driving on the road. Never carry passengers.
- 3) Always disengage P.T.O. while moving from one area of work to another.
- 4) It is recommended to use both brake pedals simultaneously for better control.
- 5) The recommended road speed should be such as to maintain full control over steering and braking.
- 6) Be careful while backing up, make sure you have good visibility.

SAFETY IN STORAGE

- 1) Provide adequate supports to prevent any accidental overturning of the Snowblower.
- 2) Do not let children play in the area where the Snowblower is stored.

2

DECALS

SAFETY DECALS

The safety decals are affixed wherever special safety precautions are indicated. Locate them on the machine and read them carefully. If a decal is damaged, lost or illegible, install a new one. The following photos indicate where each one must be installed.

3



Figure 3

⚠ ATTENTION

- 1- FOR SAFE OPERATION, FOLLOW OPERATING INSTRUCTIONS IN OPERATOR'S MANUAL.
- 2- KEEP HANDS, FEET AND CLOTHINGS AWAY FROM POWER DRIVEN PARTS.
- 3- STOP ENGINE BEFORE LEAVING THE EQUIPMENT.
- 4- MACHINE HAS TO BE COMPLETELY STOPPED BEFORE STARTING TO ADJUST OR LUBRICATE.
- 5- KEEP PEOPLE AND PETS AT SAFE DISTANCE FROM MACHINE.
- 6- KEEP ALL GUARDS AND SHIELDS IN PLACE.

- 1- POUR UN FONCTIONNEMENT SÉCURITAIRE SUIVRE LES INSTRUCTIONS DANS LE MANUEL D'OPÉRATION.
- 2- GARDER LES MAINS, PIEDS ET VÊTEMENTS ÉLOIGNÉS DES ÉLÉMENTS MOBILES OU ROTATIFS.
- 3- AVANT DE QUITTER LA MACHINE ARRÊTER LE MOTEUR.
- 4- ARRÊTER COMPLÈTEMENT LA MACHINE POUR EFFECTUER L'ENTRETIEN ET L'AJUSTEMENT.
- 5- GARDER LES GENS ET LES ANIMAUX À UNE DISTANCE SÉCURITAIRE.
- 6- GARDER TOUS LES ÉCRANS PROTECTEUR EN PLACE.

PA 93-01

Figure 2
Decal A

Part no.: A102

⚠ DANGER

TO AVOID SERIOUS INJURIES, KEEP CLEAR OF EQUIPMENT WHILE IN OPERATION.

POUR ÉVITER DES BLESSURES GRAVES SE TENIR LOIN DE CET ÉQUIPEMENT LORSQU'IL EST EN MARCHÉ.

PD 93-03

Figure 4
Decal B

Part no.: A101

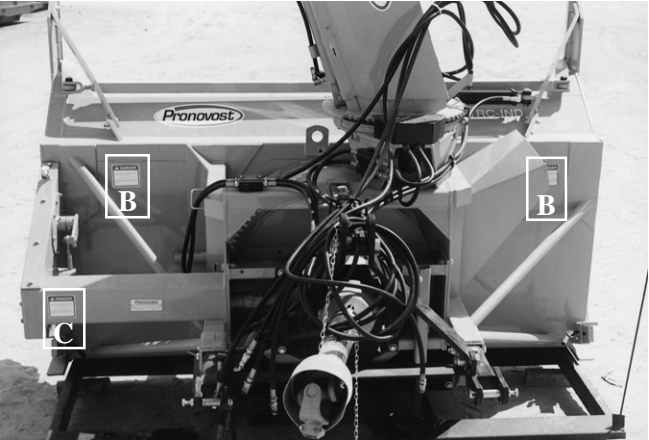

Figure 5

DECALS (cont'd)

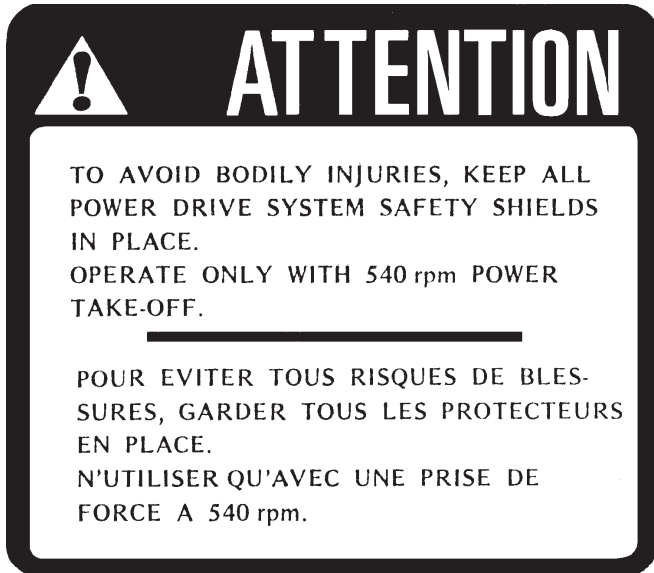

Figure 6
Decal C

Part no.: A112



Figure 7
Decal D

Part no.: A103

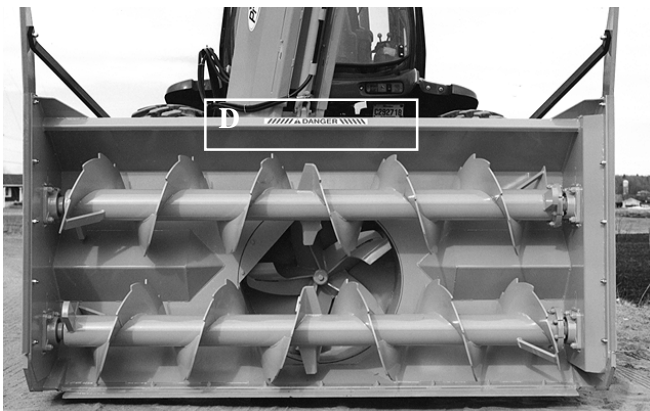

Figure 8

Decal E in Fig. 9 is located directly on the P.T.O. shaft. It is not visible when the safety shield is in place. It must never be visible when you operate the equipment.



Figure 9
Decal E

Part no.: A108

3

DECALS (cont'd)

3



Figure 10
Decal F Part no.: A 109

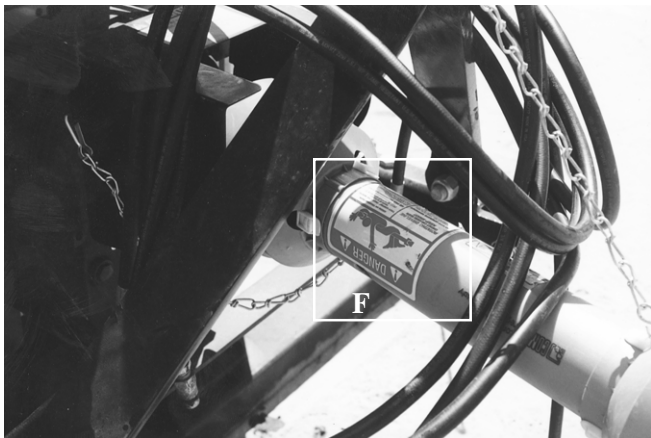
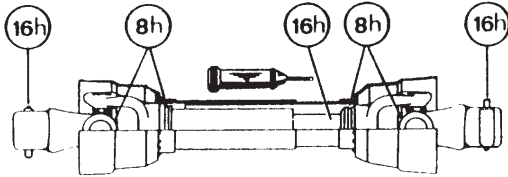

Figure 11

MAINTENANCE DECALS

The maintenance decals indicate the points requiring lubrication. Refer to maintenance section for more details.

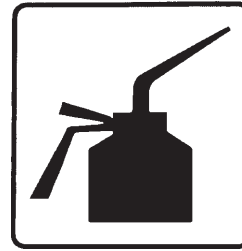

Figure 12 Part no.: A 105



Figure 13 Part no.: A 106



Figure 14
Decal G Part no.: A104

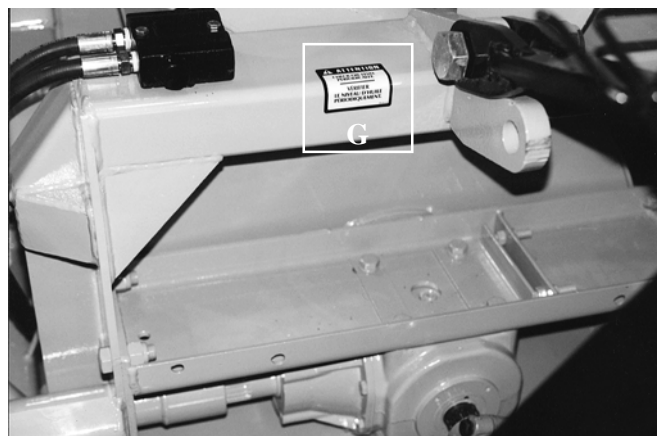

Figure 15

DECALS (cont'd)

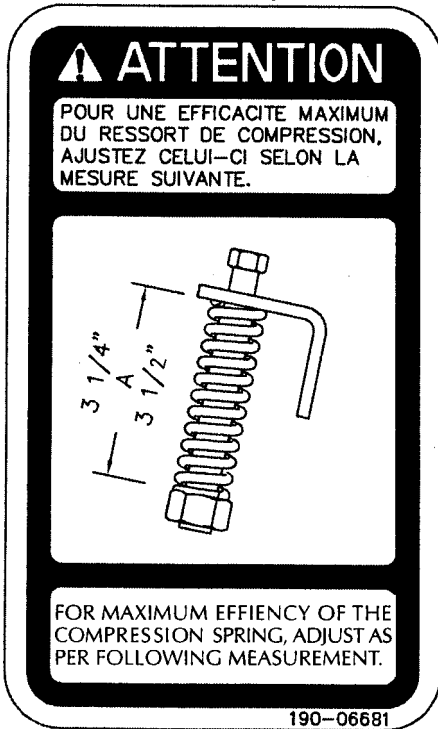

Figure 16
Decal H Part no.: 190-06681

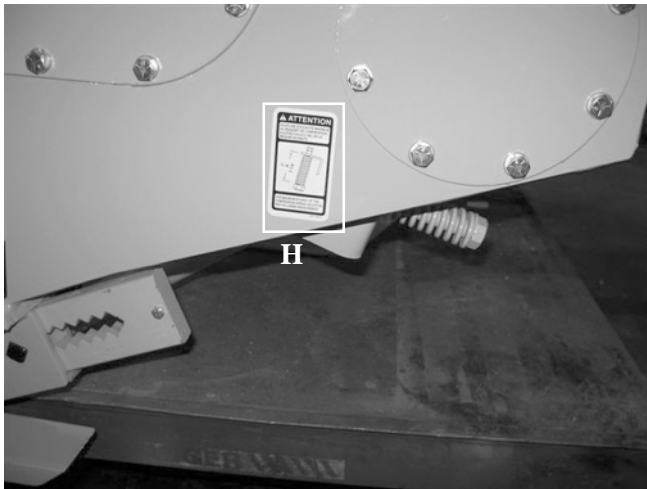

Figure 17



Figure 18
Autocollant G Pièce no.: 190-10991

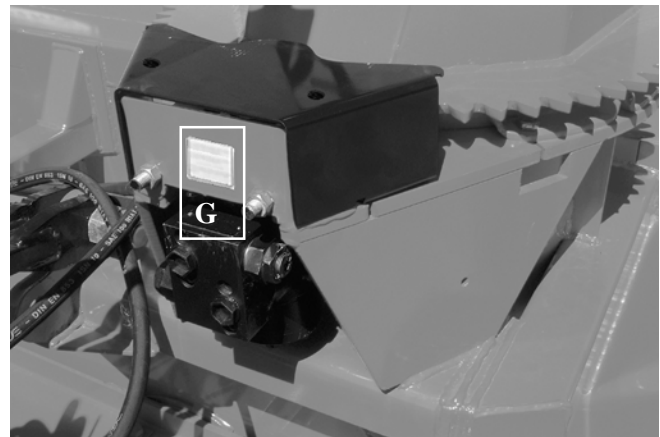

Figure 19

3

ASSEMBLY



4

Figure 20

ASSEMBLY

- 1) The Snowblower is shipped partly assembled.
- 2) Install P.T.O. shaft and place the shear pin end on the Snowblower side. Then attach safety shield support chain as shown (Fig. 20). **WARNING:** The telescoping tubes of the drive shaft must never be allowed to bottom out while maintaining a minimum overlap of 6 inches.



Figure 21

STARTING-UP

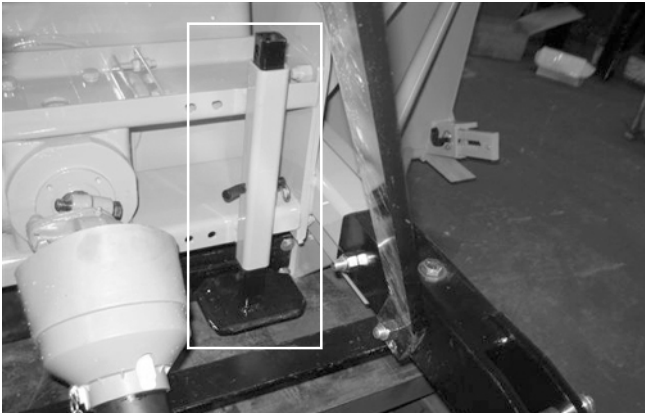

Figure 22

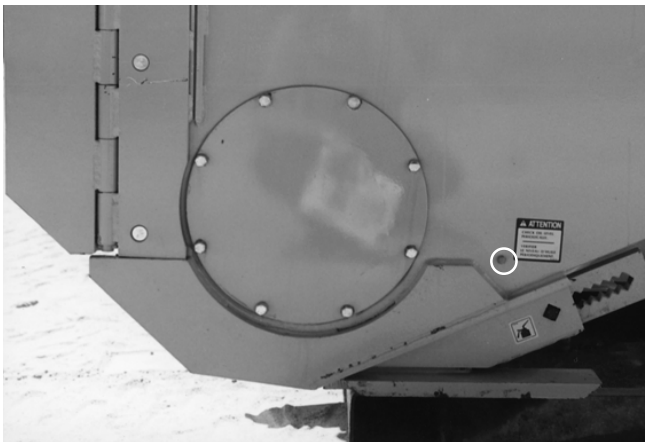

Figure 23



Figure 24

START-UP PROCEDURES

- 1) Check oil level in gearbox and in speed reducer if so equipped. Adjust to required oil level as per drawing in Parts List section. Use SAE 80W90 oil.
- 2) Lubricate all points with a good quality multipurpose grease.
- 3) Check chain take-up adjustment. The spring maintaining the tension must be compressed to a length between 3 1/4" and 3 1/2".
- 4) Verify for adequate tightness of all fastening devices. Refer to torque chart on page 43.
- 5) Adjust skid shoes according to ground conditions (Fig. 21).
- 6) Following the installation of the Snowblower on the tractor, **do not forget** to lift the storage support (Fig. 22).
- 7) Use 540 RPM drive line or if your snowblower is equipped with a 1000 to 540 RPM speed reducer, use 1000 RPM drive line.
- 8) Check oil level in auger drive chain box (Fig. 23). Fill to level of plug. Use SAE 80W90 oil.
- 9) Check impeller adjustment. The tip of the blades should be approximately 1/8" to 3/16" from the discharge wall of the drum. If necessary, adjust with the take-up screws provided (Fig. 24).
- 10) In order to avoid damaging your snowblower, adjust the speed of descent of your 3 point hitch to prevent striking the ground too hard.
- 11) Adjust the hydraulic flow in order to have a good control of the rotation speed of the chute.

STARTING-UP (cont'd)

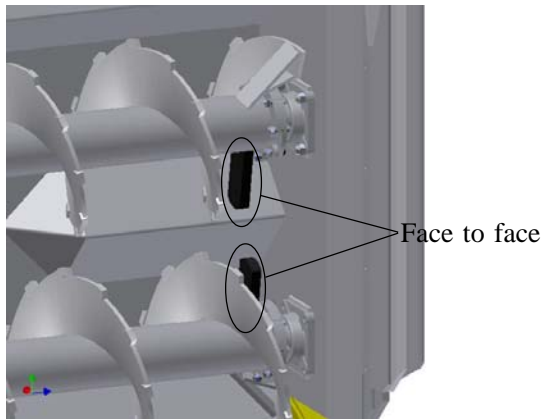

Figure 25

- 12) When replacing the chain, be sure the counterweights are face to face. This will improve the augers balance (Fig. 25).

5

MAINTENANCE

- 1) Wipe off all grease fittings with a clean cloth before adding grease in order to avoid injecting dirt and sand.
- 2) Repair or replace damaged grease fittings.
- 3) Lubricate all grease fittings every 10 hours of operation.
- 4) Oil drive chain every 8 hours of operation.
- 5) Lubricate P.T.O. shaft as indicated below:

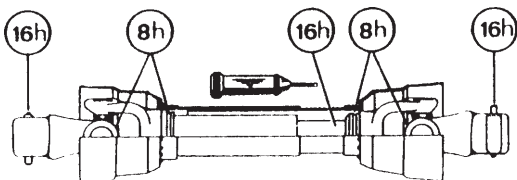

Pull out the P.T.O. And lubricate between the two tubes with low temperature grease.

- 6) Check oil level in gear box once a month. Adjust to required oil level as per drawing in Parts List section. Use SAE 80W90 oil.
- 7) Check oil level in auger drive chain box once a month. Fill to level plug. Use SAE 80W90 oil.
- 8) Check tension of drive chain every 24 hours of operation and adjust if necessary.
- 9) Check for tightness of bearing collars every 48 hours of operation.
- 10) Change gearbox oil once a year. Adjust to required oil level as per drawing in Parts List section. Use SAE 80W90 oil.

- 11) Check all nuts and bolts once a year. If necessary use torque chart on page 43.
- 12) Standard scraper blades are reversible. Reverse when one edge is worn out.
- 13) For the auger drive shaft, always use a grade 5 shear bolt.
- 14) For the PTO shaft, always use a grade 10.9 shear bolt at 540 RPM or a grade 8.8 shear bolt at 1000 RPM.
- 15) UHMW slides do not require lubrication except at the end of the season in order to prevent corrosion of steel components that are in contact with the UHMW material.

If your snowblower is equipped with the optional speed reducer

- 16) After 10 working hours, the chain's adjustment (if applicable) must be checked and every 100 working hours. Please refer to section: Maintenance on Speed Reducer.
- 17) Check oil level in speed reducer once a month. Adjust to required oil level as per drawing in Parts List section. Use SAE 80W90 oil.
- 18) Drain the oil of the speed reducer once a year. Adjust to required oil level as per drawing in Parts List section. Use SAE 80W90 oil.

6

MAINTENANCE ON SPEED REDUCER

It is extremely important that the chain inside the chain box is **tightened**. A loose chain will add shocks to the entire box (chain, sprockets, bearings and spline couplings to gearbox).

Instructions for speed reducer (with chains) maintenance

This chain box has double functions.

- 1) Reduce angles at both ends of PTO in working position by increasing the input shaft height of 8".
- 2) Increase PTO capacity by increasing speed from 540 RPM to 1000 RPM.

ADJUSTMENT OF THE CHAIN'S TENSION

After 10 working hours, the chain's adjustment must be checked. In order to do so, verify the backlash between the input and the output shaft by turning the input shaft in both directions while the output shaft remains still. If there is a play of 10° or more, the chain must then be readjusted as follows:

- 1) Remove PTO from the chain box.
- 2) Unscrew the 12 bolts 5/16" dia. (item #22) from covers (items #7 and #15) around the input shaft on both sides of the chain box (6 bolts on each side).

NOTE: Input shaft covers are eccentric with outside of covers. Therefore by turning input shaft cover, center to center distance of shafts will be changed and thus, this will adjust the chain's tension.

- 3) With a hammer and a screw-driver or a chisel, gently turn both covers in the same direction until the next hole of the cover is in line with the threaded hole of the chain box.

IMPORTANT: Make sure that the covers are turned in the same direction and by the same number of holes.

Otherwise, both shafts will not be parallel and serious damages might arise.

- 4) Verify the backlash between both shafts, as described above. If the difference is too high, repeat the operation explained in point 3. If the backlash is correct, reinstall the bolts and the PTO.
- 5) Verify the backlash every 100 working hours.

MAINTENANCE ON SPEED REDUCER

- 1) Check oil level in speed reducer once a month. Adjust to required oil level as per drawing in Parts List section. Use SAE 80W90 oil.
- 2) Drain the oil of the speed reducer once a year. Adjust to required oil level as per drawing in Parts List section. Use SAE 80W90 oil.

6

STORAGE

- 1) Store the Snowblower in a cool, dry place.
- 2) Support the Snowblower with wooden blocks.
- 3) Keep all piston rods in the retracted position. This will assure better protection against the elements.
- 4) Clean your Snowblower.
- 5) Thoroughly inspect all parts of the Snowblower. Replace or repair worn or defective parts.
- 6) Touch-up or repaint if necessary.
- 7) Lubricate all points before storage.

TROUBLESHOOTING

P.T.O. SHAFT

PROBLEM	POSSIBLE CAUSE	CORRECTION
<ul style="list-style-type: none"> - Premature wear of U-joints and/ or bluish color of cross journals. 	<ul style="list-style-type: none"> - Insufficient lubrication. - Excessive working angle. - Poor quality lubricant. 	<ul style="list-style-type: none"> - Follow lubrication recommendations. - Replace defective U-joints. - Make sure the Snowblower inlet face is perpendicular to the ground and if possible readjust 3-point hitch in order to position the Snowblower further away from tractor. - Use high quality lubricant.
<ul style="list-style-type: none"> - Gripping or premature wear of telescoping members. 	<ul style="list-style-type: none"> - Too much sliding under load. - Tube overlap too-short: minimum recommended is 6". - Insufficient lubrication. - Contaminants (sand, etc.). 	<ul style="list-style-type: none"> - Avoid raising Snowblower while in operation. - Readjust 3-point hitch in order to position the Snowblower closer to the tractor. - Follow lubrication recommendations. - Replace defective telescopic members.
<ul style="list-style-type: none"> - Damaged or jammed locking pin or bolt. 	<ul style="list-style-type: none"> - Pin or orifice contaminated by sand, ice, etc. - Telescoping members too long, exerting pressure on locking device. 	<ul style="list-style-type: none"> - Clean and grease. - Readjust 3-point hitch in order to position the Snowblower further away from tractor or shorten tubes.
<ul style="list-style-type: none"> - Premature wear of guard tube bearing ring. 	<ul style="list-style-type: none"> - Lack of lubrication. - Wrong installation of guard chain. - Part of the guard in contact with the equipment. 	<ul style="list-style-type: none"> - Follow lubrication instructions. - Adjust chain to prevent interference between guard & equipment. - Replace worn or damaged bearing rings.
<ul style="list-style-type: none"> - Cut or deformed safety guard tubes. 	<ul style="list-style-type: none"> - Tubes in contact with the equipment. 	<ul style="list-style-type: none"> - Eliminate any interference between tubes and equipment or tractor. - Replace damaged tubes.

TROUBLESHOOTING (cont'd)

SNOWBLOWER

PROBLEM	POSSIBLE CAUSE	CORRECTION
- The snow is not being thrown as far as usual.	- Tractor RPM too low. - Gap too wide between impeller blade tip and drum outlet wall. - Insufficient tractor HP.	- Raise P.T.O. speed to a minimum of 540 RPM. - Adjust impeller blades closer to drum outlet (1/8" to 3/16"). - Reduce travel speed.
- Frequent plugging of discharge chute.	- Tractor RPM too low. - Tractor RPM reduced too early with snow still in the Snowblower. - Slippage of PTO clutch mechanism. - Wet snow condition.	- Raise P.T.O. speed to a minimum of 540 RPM. - Make sure the Snowblower is completely empty before reducing RPM, especially on tractors with foot controlled RPM. - Repare clutch. - Reduce travel speed. - Remove the chute access panel.
- The impeller will not turn.	- Shear bolt broken on drive shaft.	- Replace shear bolt.
- The auger will not turn.	- Shear bolt broken on drive shaft. - Shear bolt broken on auger drive shaft. - Broken drive chain.	- Replace shear bolt. - Replace shear bolt. - Fix or replace chain.
- The rotating drum will not turn.	- Ice accumulation. - Wrong hydraulic connections.	- Remove ice. - Check hydraulic connections.
- Rotating drum will not hold it's position when blowing via the spout.	- Cushion valve setting too low. - Tension of the spring in the drum locking mechanism insufficient.	- Reset cushion valve up to 1800 psi (max.) - Increase tension of spring by adding shim(s).
- The chute will not turn.	- Ice accumulation. - Wrong hydraulic connections.	- Remove ice. - Check hydraulic connections.

SPECIFICATIONS

Model	P-982TRC-150	
Horse power required	100 to 150 HP	
Approximative performance	800 tons imp. / hour with 125 HP tractor	
Height including telescopic chute	149" extended / 123" retracted	
Height - chute base	51 1/4"	
Frame height	48"	
Lateral blades height	Std.	58 3/4"
	Opt. (T1 or hyd.)	77 3/4"
Working width	98"	
Impeller diameter	34"	
Depth of drum	15"	
Impeller blades	6 replaceable 3/8" carbon steel blades	
Shear bolt	1 for the impeller + 1 for the auger drive	
Size of impeller shaft	2"	
P.T.O. speed required	540 RPM without reducer 1000 RPM with reducer	
Reducer	Optional (150 HP at 1000 RPM) 1000/540 RPM (1.86 to 1 ratio)	
Impeller speed	540 RPM	
Number of augers	2 x 18" full flight spiked augers with welded carbon steel teeth	
Auger ball bearing	2 1/2" (heavy duty cast iron flange)	
Drive chain	No. 100HV Reynolds in oil bath	
Replaceable scraper blade	6" x 1/2" carbon steel sharpened	
Adjustable skid shoes	Industrial with carbide sole (quick adjustment)	
Lateral skid shoe for sidewalk	Optional with carbide sole	
Drum rotation	Hydraulic motor and cushion valve included	
Chute rotation	Hydraulic motor and cushion valve included	
P.T.O. shaft	No. 9 (V90)	
	Yoke 1 3/8"-6 splines for tractor output 540 RPM	
	Yoke 1 3/8"-21 splines for tractor output 1000 RPM	
	Yoke 1 3/4"-20 splines for tractor output 1000 RPM	
3-point hitch	Category 2	
Frame	Sides	5/16"
	Back	9 gages
	Drum	Carbon steel 1/4"
Center of gravity	From the 3-points hitch adjusted at its shortest 40 3/16" (1021 mm)	
Weight	3960 lbs (with telescopic chute)	

Design and specifications subject to change without notice.

INDUSTRIAL SNOWBLOWER P-982TRC-150

170-03983

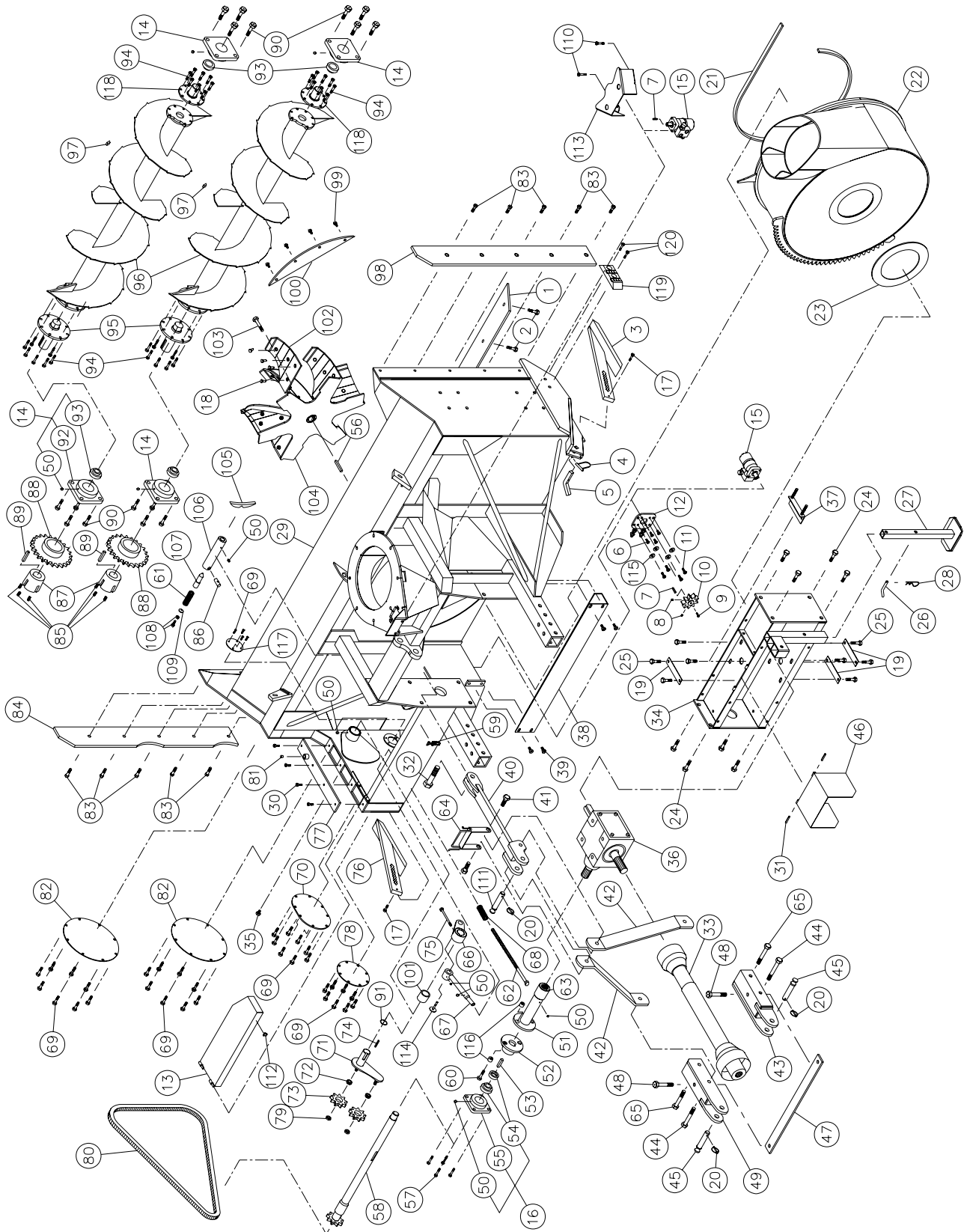

INDUSTRIAL SNOWBLOWER P-982TRC-150 (cont'd)

REF.	PART #	DESCRIPTION	QTY
1	140-10512	Scraper blade, carbon steel, not reversible, sharpened 1/2"x6"x90 7/8" lg	1
2	319-40340	Plow bolt 1/2" NC x 2" lg + nut & lock washer	9
3	110-32874	Skid shoe (right side)	1
4	8112	Lock pin 1/4"	2
5	140-03361	Skid shoes lock	2
6	300-36250	Bolt 3/8" NC x 1" lg + nylon locknut	4
7	8369	Key for hydraulic motor	2
8	323-36160	Hexagonal socket set screw 3/8" NC x 3/8" lg.	2
9	300-32220	Bolt 1/4" NC x 3/4" lg + lock washer	2
10	110-04721	Sprocket 9 teeth	1
11	300-38310	Bolt 7/16" NC x 1 1/2" lg + nylon locknut	4
12	110-18441	Orbit motor support + 4 nut 7/16" NC	1
13	110-21483	Drive shaft guard	1
14	UCF213-40	Bearing 2 1/2" + flange + 1 grease fitting	4
15	MLH315	Hydraulic motor with cushion valve	2
16	HCFS211-32	Bearing 2" + flange + 1 grease fitting	1
17	300-32310	Bolt 1/4" NC x 1 1/2" lg + nylon locknut	2
18	319-40325	Plow bolt 1/2" NC x 1 3/4" lg + nut & lock washer	24
19	140-10761	Back plate	3
20	Std.	Lynch pin 1/4" x 1 3/4"	3
21	9430	U-shaped UHMW 3/8" x 7/8" x 110 1/8" lg	1
22	110-29071	Rotary drum 34" dia.	1
23	9432	UHMW flat washer 3/16" x 8 7/8" i.d. x 12" o.d.	1
24	300-46340	Bolt 3/4" NC x 2" lg + nylon locknut	8
25	300-44310	Bolt 5/8" NC x 1 1/2" lg + lock washer	8
26	8220	Storage support pin	1
27	9462	Storage support	1
28	Std.	Hitch pin clip 5/32"	1
29	120-03654	Frame P-982TRC-150	1
30	300-38250	Bolt 7/16" NC x 1" lg + lock washer	4
31	Std.	Roll pin 5/16" x 2" lg	2
32	300-54460	Bolt 1 1/4" NC x 4" lg + nylon locknut	1
33	9599	P.T.O. shaft V90 1 3/8"-21 splines	as required
33	9598	P.T.O. shaft V90 1 3/8"-6 splines	as required
33	9604	P.T.O. shaft V90 1 3/4"-20 splines	as required
34	110-01683	Gear box support	1
35	3159-02	Hexagonal plug 1/8" NPT	1
36	9307	Gear box T-279	1
37	110-05281	Adjustment plate for gear box + 4 nuts 1/2" NC	1
38	130-06571	Guard for ring gear segment	1
39	300-40280	Bolt 1/2" NC x 1 1/4" lg + nylon locknut + flat washer	4
40	110-30841	Upper hitch	1
41	300-46400	Bolt 3/4" NC x 3" lg + nylon locknut + flat washer 1 1/2" o.d.	2
42	140-05592	3-point side bar	2
43	110-15214	Right lower hitch	1
44	302-46610	Bolt 3/4" NF x 6 1/2" lg + nylon locknut	2
45	9269	Pin category 2	2
46	110-12541	Hinged P.T.O. shroud	1
47	140-03561	3-point hitch reinforcement	1
48	302-46550	Bolt 3/4" NF x 5 1/2" lg + nylon locknut	2
49	110-15213	Left lower hitch	1

INDUSTRIAL SNOWBLOWER P-982TRC-150

REF.	PART #	DESCRIPTION	QTY
50	Std.	Grease fitting 1/4-28 straight	10
51	110-11372	Side shaft & shearplate (long side) + splined adaptor (20 splines)	1
52	110-11361	Side shaft & shearplate (short side)	1
53	140-08541	Key for auger drive shaft & shearplate (short side)	1
54	HC211-32	Bearing 2" with eccentric collar	1
55	FSD211	Flange 4 holes	1
56	9285	Key for impeller	1
57	300-44340	Bolt 5/8" NC x 2" lg + nylon locknut	4
58	110-14633	Auger drive shaft 35-9/16" lg	1
59	8374	Adjustable clamp fastener (welded)	1
60	300-38355	Bolt 7/16" NC x 2 1/4" lg + nylon locknut	1
61	9473	Compression spring	1
62	110-17751	Threaded rod for idler adjustment	1
63	110-13441	Splined adaptor 1 3/4" - 20 (welded) with bronze bushing	1
64	110-15201	Hoses support	1
65	302-46580	Bolt 3/4" NF x 6" lg + nylon locknut	2
66	110-17732	Idler (outside part)	1
67	110-17762	Threaded tube for idler adjustment	1
68	9687	Compression spring	1
69	309-32010	Bolt M8-1.25 x 10 mm	38
70	130-12404	Idler cover	1
71	110-17771	Idler (inside part)	1
72	160-02171	Spacer	2
73	9470	Idler sprocket no 100A9 H3/4	2
74	140-12161	Idler key	1
75	306-40460	Bolt 1/2" NC x 4" lg GR 12 + nylon locknut	1
76	110-32873	Skid shoe (left side)	1
77	110-13862	Upper chain guard cover	1
78	130-12393	Chain guard cover (left side)	1
79	346-47000	Nylon locknut 3/4" NC thin	2
80	190-07941	Chain #100 HD x 118 3/4" (95 links)	1
80	59-100 HD	Offset link #100 HD	1
80	26A100 HD	Connecting link #100 HD	1
81	9619	Vent plug 1/2" NPT	1
82	130-12383	Chain guard cover	2
83	319-40325	Plow bolt 1/2" NC x 1 3/4" lg + nut & lock washer	10
84	130-19591	Left lateral blade	1
85	318-40310	Hexagonal socket set screw 1/2"-13 x 1 1/2"	6
86	150-02561	Pin	1
87	9715	Male adaptor "taper-lock"	2
88	110-13322	Sprocket for auger 100A24 x 1T 6.250 + female adaptor "taper-lock"	2
89	140-23961	Key (sprocket for auger)	2
90	300-46370	Bolt 3/4" NC x 2 1/2" lg + nylon locknut	16
91	OR-224	Seal 1/8" x 1 3/4" i.d. x 2" o.d.	1
92	FS213	Flange 4 holes	4
93	UCF213-40	Bearing 2 1/2" with eccentric collar	4
94	300-40325	Bolt 1/2" NC x 1 3/4" lg + nut & lock washer	32
95	110-40301	Auger hub (auger-drive end)	2
96	110-38132	Full flight spiked auger with welded carbon steel teeth (61 on each auger)	2
97	130-13861	Carbon steel tooth on the auger (61 on each auger)	122
98	130-19581	Right lateral blade	1

INDUSTRIAL SNOWBLOWER P-982TRC-150

REF.	PART #	DESCRIPTION	QTY
99	300-38280	Bolt 7/16" NC x 1 1/4" lg + nylon locknut	4
100	130-05911	Deflector	1
101	160-08421	Aluminium bronze bushing 1 3/4" i.d. x 2" lg	1
102	130-59401	Impeller blade	6
103	300-44310	Bolt 5/8" NC x 1 1/2" lg + lock washer	1
104	110-29082	Impeller with bolted blades	1
105	130-08441	Stop block for drum lock (welded on drum)	1
106	160-03952	Body - drum lock (welded on frame)	1
107	150-01542	Latch pin - drum lock	1
108	300-38325	Bolt 7/16" NC x 1 3/4" lg (full length thread) + lock nut	1
109	130-08471	Washer	1
110	300-34280	Bolt 5/16" NC x 1 1/4 lg + nylon locknut	2
111	150-05961	Pin category 2 (top link)	1
112	8375	Hook for adjustable clamp fastener (welded)	1
113	130-14282	Guard	1
114	110-38531	Idler attachment + nylon locknut 3/8"	1
115	150-12741	Flat washer	4
116	150-02501	Bushing 7/16" i.d. x 1" o.d. x 3/4" lg (welded)	2
117	130-71781	Cover	1
118	110-40311	Auger hub (auger-idler end)	2
119	190-11071	Lateral skid shoe with carbide sole (1)	opt.
120	300-44370	Bolt 5/8" NC x 2 1/2" lg + nylon locknut (2)	opt.

INDUSTRIAL CHUTE PCG-IND

170-03473R3

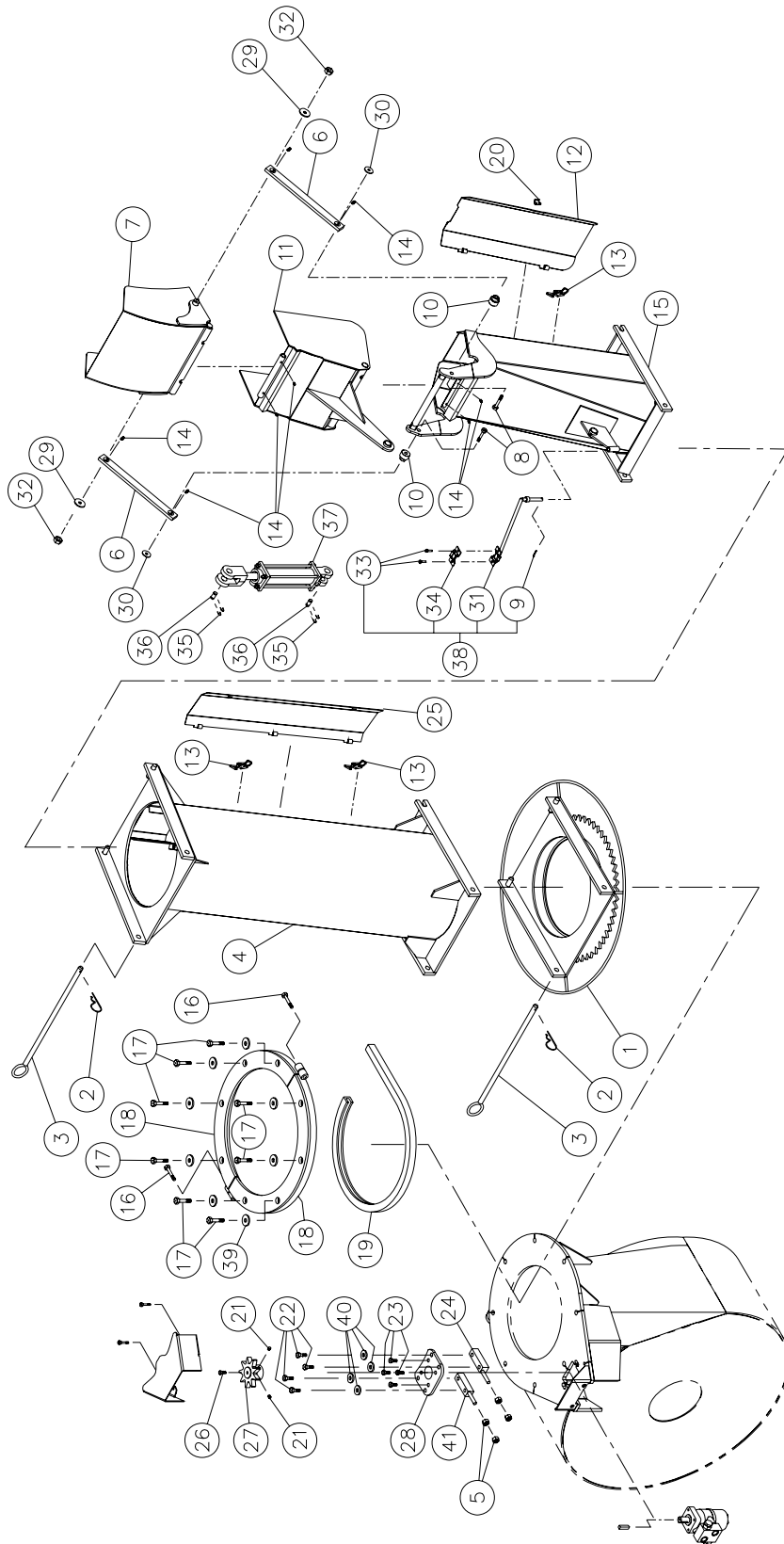

INDUSTRIAL CHUTE PCG-IND

REF.	PART #	DESCRIPTION	QTY
1	110-00681	Chute adaptor with quick attach	1
2	Std.	Hitch pin clip 5/32"	2
3	9414	Pin for quick attach (adaptor & extension)	2
4	PR-IND	Extension 48"	opt.
5	336-38000	Nut 7/16" NC	4
6	140-13931	Connecting rod	2
7	110-38361	Upper deflector	1
8	300-40370	Bolt 1/2" NC x 2 1/2" lg + nylon locknut (thin)	2
9	Std.	Cotter pin 1/8" x 1" lg	1
10	150-05311	Spacer for connecting rod	2
11	110-38371	Lower deflector	1
12	110-22933	Lower deflector	1
13	8376	Adjustable clamp fastener (welded)	1
14	Std.	Grease fitting 1/4" - 28 straight	8
15	110-38441	Chute base	1
16	300-38400	Bolt 7/16" NC x 3" lg + nylon locknut	2
17	300-40400	Bolt 1/2" NC x 3" lg + nylon locknut & 16 flat washers	8
18	110-12351	Retaining bracket	2
19	190-03381	U-shaped UHMW +/- 16" i.d.	1
20	8377	Hook for clamp fastener (welded)	1
21	323-36160	Hexagonal socket set screw 3/8" NC x 3/8" lg	2
22	300-38370	Bolt 7/16" NC x 2 1/2" lg + nylon locknut & flat washer 3/8"	4
23	300-36250	Bolt 3/8" NC x 1" lg + lock washer	4
24	110-38321	Spacer	1
25	110-22952	Access panel for extension 48" # PR-92104P	opt.
26	300-32220	Bolt 1/4" NC x 3/4" lg + lock washer	1
27	110-36731	Sprocket 9 teeth T1	1
28	130-08152	"Orbit" motor support	1
29	378-36500	Upper flat washer for connecting rod	2
30	378-37500	Lower flat washer for connecting rod	2
31	110-01112	Hoses support rod	1
32	346-36000	Nylon locknut 3/8" NC	2
33	300-32250	Bolt 1/4" NC x 1" lg + nylon locknut	2
34	140-13071	Hoses support plate	1
35	Std.	Hairpin cotter 7/8"	4
36	6004	Clevis pin 1" x 3 1/8"	2
37	25TR08	Cylinder 2 1/2" x 8" stroke	1
38	TSB-74104	Hoses support for deflector cylinder	1
39	150-12731	Flat washer	16
40	150-12741	Flat washer	4
41	110-38322	Spacer	1

HYDRAULIC TELESCOPIC CHUTE PCT-IND

170-02397R2

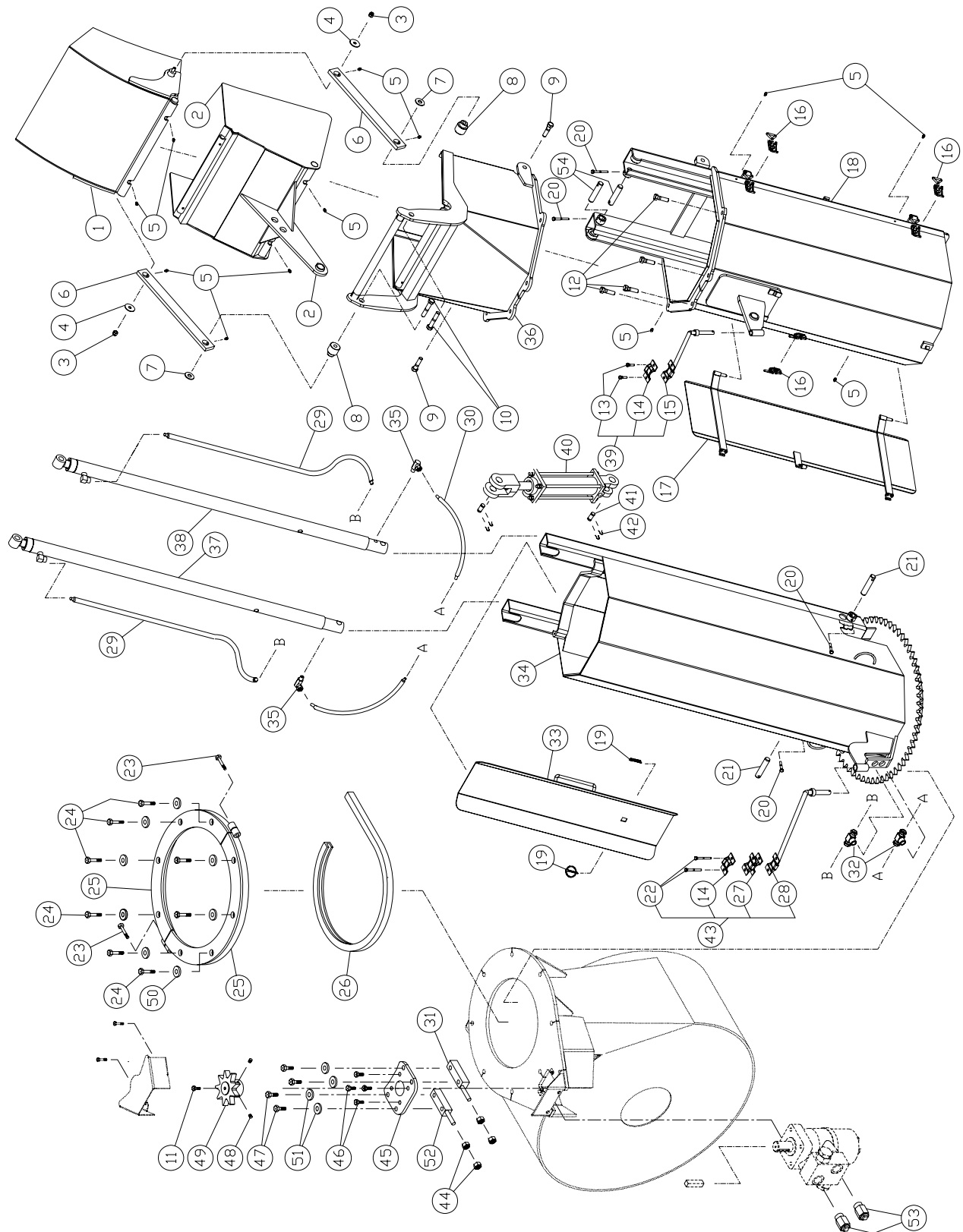

HYDRAULIC TELESCOPIC CHUTE PCT-IND

REF.	PART #	DESCRIPTION	QTY
1	110-13464	Upper chute deflector	1
2	110-13492	Lower chute deflector	1
3	346-36000	Nylon locknut 3/8"	2
4	378-36500	Washer 3/8" i.d. x 1 1/2" o.d.	2
5	Std.	Grease fitting 1/4"-28 straight	12
6	140-13931	Connecting rod	2
7	378-37500	Washer 1/2" i.d. x 1 3/8" o.d.	2
8	150-05311	Spacer for connecting rod	2
9	300-40340	Bolt 1/2" NC x 2" lg + nylon locknut	2
10	300-40380	Bolt 1/2" NC x 2 3/4" lg + nylon locknut	2
11	300-32220	Bolt 1/4" NC x 3/4" lg + lock washer	1
12	300-40325	Bolt 1/2" NC x 1 3/4" lg + 2 washers + nylon locknut	4
13	300-32250	Bolt 1/4" NC x 1" lg + nylon locknut	2
14	140-13071	Hoses mounting plate	2
15	110-01122	Mounting support plate for upper extension	1
16	8376	Adjustable clamp fastener (welded)	3
17	110-29391	Access panel for upper extension	1
18	110-26642	Upper extension	1
19	Std.	Lynch pin 3/16" x 1 1/4"	2
20	300-32325	Bolt 1/4" NC x 1 3/4" lg + nylon locknut	4
21	150-12701	Pin	2
22	300-32370	Bolt 1/4" NC x 2 1/2" lg + nylon locknut	2
23	300-38400	Bolt 7/16" NC x 3" lg + nylon locknut	2
24	300-40415	Bolt 1/2" NC x 3 1/4" lg + nylon locknut	8
25	110-12351	Retaining bracket	2
26	190-03381	U-shaped UHMW + - 16" i.d.	1
27	110-20611	Hoses mounting plate	1
28	110-04982	Mounting support plate for lower extension	2
29	190-08231	Hose 1/4" SAE 100R2AT - 500 PSI x 63 1/2" lg	2
30	190-08241	Hose 1/4" SAE 100R2AT - 500 PSI x 20 1/2" lg	2
31	110-38321	Spacer	2
32	9456-06-06	«T» female 3/8" NPT swivel , female 3/8" NPT	2
33	110-26671	Access door for lower extension	1
34	110-13732	Lower extension	1
35	9406-04-04	Elbow 90 degrees 1/4" NPT swivel	2
36	110-34182	Hexagonal extension	1
37	15 PC 32G	Cylinder 1 1/2" x 32" stroke	1
38	15 PC 32D	Cylinder 1 1/2" x 32" stroke	1
39	TSB-74104	Hoses support for deflector cylinder	1
40	25TR08	Cylinder 2 1/2" x 8" stroke	1
41	6004	Clevis pin 1" x 3 1/8" lg (2)	2
42	Std.	Hairpin cotter 7/8" (4)	4
43	TSB-74104-IND	Hoses support on chute base	1
44	336-38000	Nut 7/16" NC	4
45	130-08152	"Orbit" motor support	1
46	300-36250	Bolt 3/8" NC x 1" lg + lock washer	4
47	300-38370	Bolt 7/16" X 2 1/2" lg + nylon locknut & flat washer	4
48	323-36160	Hexagonal socket set screw 3/8" NC x 3/8" lg	2
49	110-36731	Sprocket 9 teeth T1	1
50	150-12731	Flat washer	16
51	150-12741	Flat washer	4
52	110-38322	Spacer	1
53	110-40071	Restrictor	2
54	150-13181	Pin	2

SEMI-INDUSTRIAL CHUTE PSIG-92104

170-03453R3

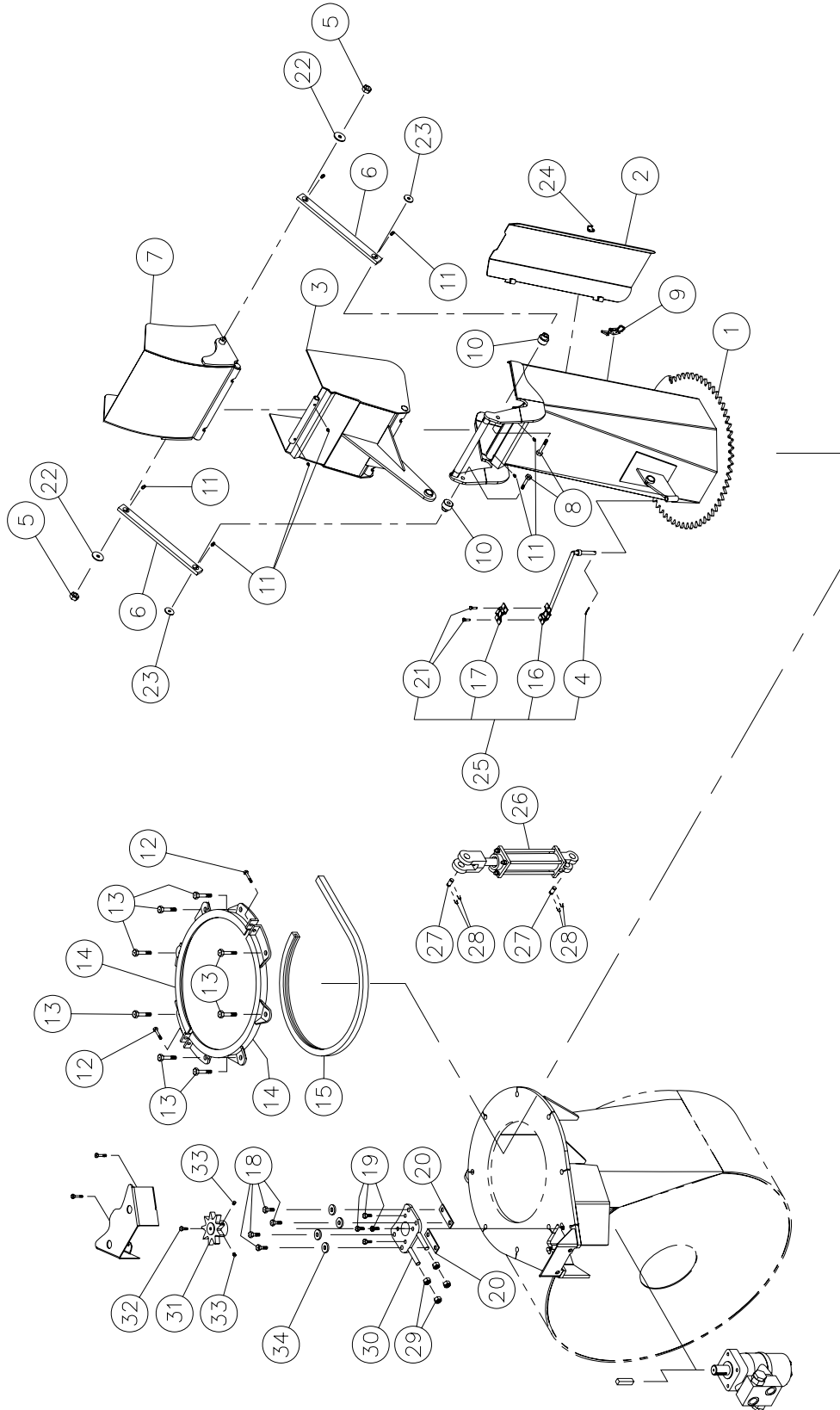

SEMI-INDUSTRIAL CHUTE PSIG-92104

REF.	PART #	DESCRIPTION	QTY
1	110-22554	Chute base	1
2	110-22933	Access panel	1
3	110-22232	Lower chute deflector	1
4	Std.	Cotter pin 1/8" X 1"	1
5	346-36000	Nylon locknut 3/8" NC	2
6	140-13931	Connecting rod	2
7	110-22242	Upper chute deflector	1
8	300-40400	Bolt 1/2" NC x 3" lg + nylon locknut	2
9	8376	Clamp fastener (welded)	1
10	150-05311	Spacer for connecting rod	2
11	Std.	Grease fitting 1/4" - 28 droit	8
12	300-34340	Bolt 5/16" NC x 2" lg + nylon locknut	2
13	300-40310	Bolt 1/2" NC x 1 1/2" lg + nylon locknut & flat washer	8
14	110-00832	Retaining bracket	2
15	9359	U-shaped UHMW +/- 16 1/2" d.i.	1
16	110-01112	Hoses support rod	1
17	140-13071	Hoses support plate	1
18	300-38325	Bolt 7/16" NC x 1 3/4" lg + lock washer & flat washer 3/8"	4
19	300-36250	Bolt 3/8" NC x 1" lg + lockwasher	4
20	140-09571	Spacer 1/8" x 1" x 3 1/4" lg	2
21	300-32250	Bolt 1/4" NC x 1" lg. + nylon locknut	2
22	378-36500	Upper flat washer for connecting rod	2
23	378-37500	Lower flat washer for connecting rod	2
24	8377	Hook for adjustable clamp fastener (welded)	1
25	TSB-74104	Hoses support for deflector cylinder	1
26	25TR08	Cylinder	opt.
27	6004	Clevis pin 1" x 3 1/8" (2)	opt.
28	Std.	Hairpin cotter 7/8" (4)	opt.
29	336-38000	Nut 7/16" NC	4
30	110-20811	"Orbit" motor support	1
31	110-04182	Sprocket 9 teeth	1
32	300-32220	Bolt 1/4" NC x 3/4" lg + lock washer	1
33	323-36160	Hexagonal socket set screw 3/8" NC x 3/8" lg	2
34	150-12741	Flat washer	4

HYDRAULIC TELESCOPIC CHUTE PCT-92104

170-04071R2

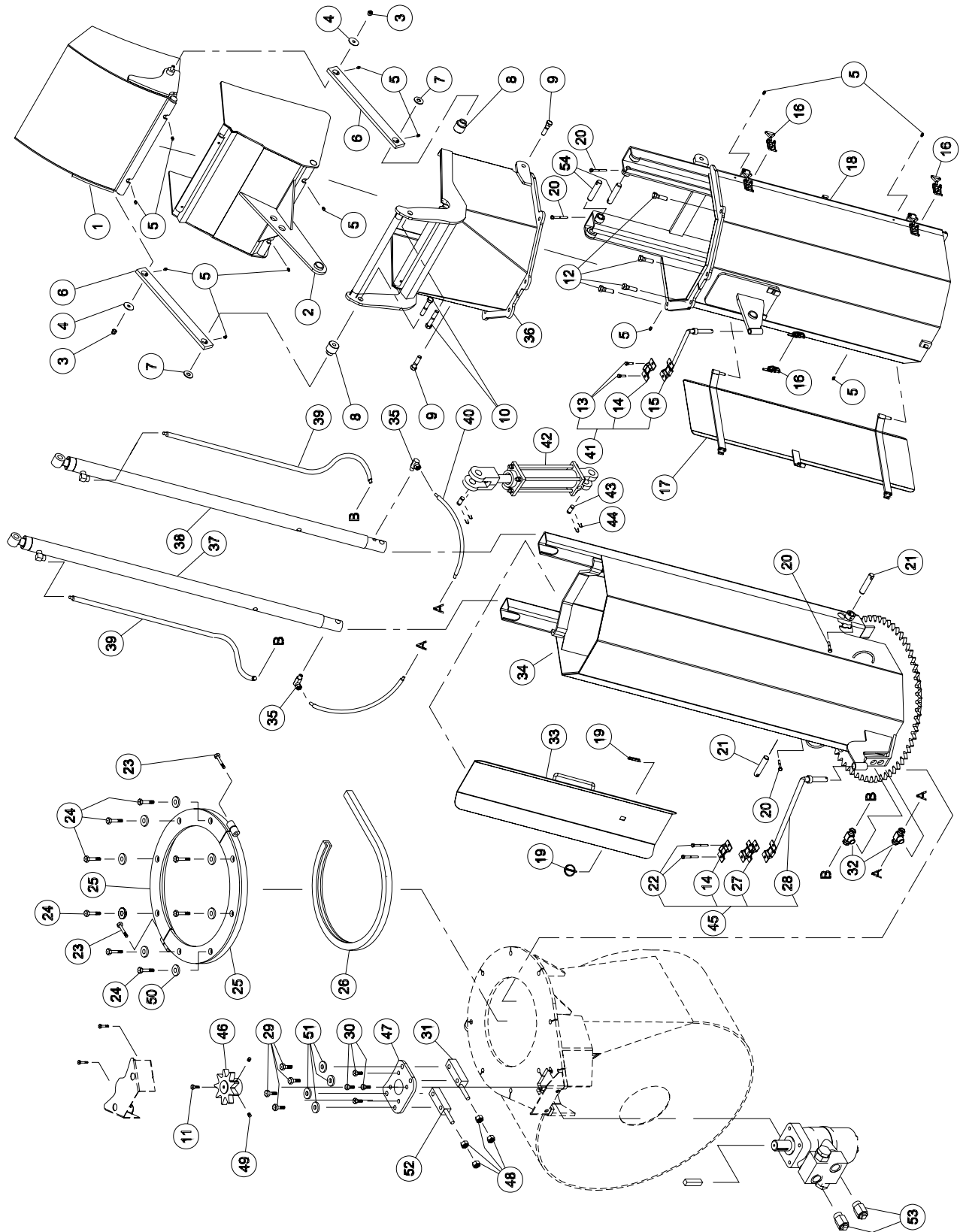

HYDRAULIC TELESCOPIC CHUTE PCT-92104

REF.	PART #	DESCRIPTION	QTY
1	110-29112	Upper chute deflector	1
2	110-29121	Lower chute deflector	1
3	346-36000	Nylon locknut 3/8"	2
4	378-36500	Washer 3/8" i.d. x 1 1/2" o.d.	2
5	Std.	Grease fitting 1/4"-28 straight	12
6	140-13931	Connecting rod	2
7	378-37500	Washer 1/2" i.d. x 1 3/8" o.d.	2
8	150-05311	Spacer for connecting rod	2
9	300-40340	Bolt 1/2" NC x 2" lg + nylon locknut	2
10	300-40380	Bolt 1/2" NC x 2 3/4" lg + nylon locknut	2
11	300-32220	Bolt 1/4" NC x 3/4" lg + lock nut	1
12	300-40310	Bolt 1/2" NC x 1 1/2" lg + 2 washers + nylon locknut	4
13	300-32250	Bolt 1/4" NC x 1" lg + nylon locknut	2
14	140-13071	Hoses mounting plate	2
15	110-01122	Mounting support plate for upper extension	1
16	8376	Adjustable clamp fastener (welded)	3
17	110-29391	Access panel for upper extension	1
18	110-26642	Upper extension	1
19	Std.	Lynch pin 3/16" x 1 1/4"	2
20	300-32325	Bolt 1/4" NC x 1 3/4" lg + nylon locknut	4
21	150-12701	Pin	2
22	300-32370	Bolt 1/4" NC x 2 1/2" lg + nylon locknut	2
23	300-38400	Bolt 7/16" NC x 3" lg + nylon locknut	2
24	300-40415	Bolt 1/2" NC x 3 1/4" lg + nylon locknut	8
25	110-12351	Retaining bracket	2
26	190-03381	U-shaped UHMW + - 16" i.d.	1
27	110-20611	Hoses mounting plate	1
28	110-04982	Mounting support plate for lower extension	1
29	300-38370	Bolt 7/16" NC x 2 1/2" lg + nylon locknut & flat washer	4
30	300-36250	Bolt 3/8" NC x 1" lg + lock washer	4
31	160-38321	Spacer 1/2" i.d. x 1" o.d. x 59/64" lg	1
32	9456-06-06	«T» female 3/8" NPT swivel , female 3/8" NPT	2
33	110-26671	Access door for lower extension	1
34	110-26651	Lower extension	1
35	9406-04-04	Elbow 90 degrees 1/4" NPT swivel	2
36	110-29102	Hexagonal extension	1
37	15 PC 32G	Cylinder 1 1/2" x 32" stroke	1
38	15 PC 32D	Cylinder 1 1/2" x 32" stroke	1
39	190-08231	Hose 1/4" SAE 100R2AT - 500 PSI x 63 1/2" lg	2
40	190-08241	Hose 1/4" SAE 100R2AT - 500 PSI x 20 1/2" lg	2
41	TSB-74104	Hoses support for deflector cylinder	1
42	25TR08	Cylinder 2 1/2" x 8" stroke	opt.
43	6004	Clevis pin 1" x 3 1/8" lg	2
44	Std.	Hairpin cotter 7/8"	4
45	TSB-74104-IND	Hoses support on chute base	1
46	110-36731	Sprocket 9 teeth T1	1
47	130-08152	"Orbit" motor support	1
48	336-38000	Nut 7/16" NC	4
49	323-36160	Hexagonal socket set screw 3/8" NC x 3/8" lg	1
50	150-12731	Flat washer	16
51	150-12741	Flat washer	4
52	110-38322	Spacer	1
53	110-40071	Restrictor	2
54	150-13181	Pin	2

LATERAL BLADES

170-02695R1

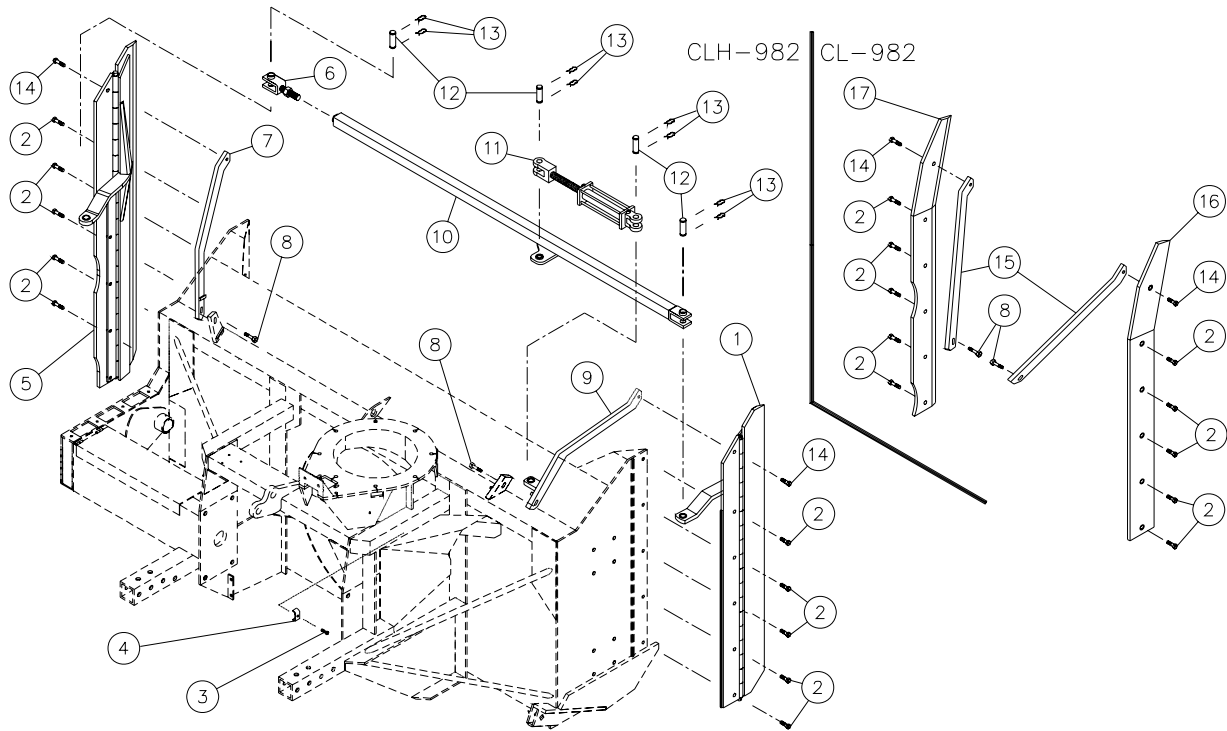

REF.	PART #	DESCRIPTION	CLH-982	CL-982
1	110-14442	Sharpened lateral blade (carbon steel, right side)	1	-
2	319-40325	Plow bolt 1/2" NC x 1 3/4" lg + nut & lock washer	10	10
3	300-34310	Bolt 5/16" NC x 1 1/2" lg	1	-
4	140-00481	Hose clamp	1	-
5	110-15642	Sharpened lateral blade (carbon steel, left side)	1	-
6	110-14121	Main hydraulique ajustable + nut 1"-14 NF	1	-
7	110-14162	Left lateral blade strengthener	1	-
8	300-40370	Bolt 1/2" NC x 2 1/2" lg + nylon locknut & flat washer	2	2
9	110-14152	Right lateral blade strengthener	1	-
10	110-15652	Connecting tube	1	-
11	25TR08	Cylinder 2.5" x 8" stroke	1	-
12	190-11271	Pin for cylinder 1" x 3 1/8" lg	4	-
13	Std.	Cotter pin 5/32" x 1 1/2" lg	8	-
14	319-40340	Plow bolt 1/2" NC x 2" lg + nut & lock washer	2	2
15	140-09562	Side strengthener	-	2
16	110-13232	Lateral blade (carbon steel, right side)	-	1
17	110-14702	Lateral blade (carbon steel, left side)	-	1

10

REDUCTION GEAR BOX OPTIONS

170-02681

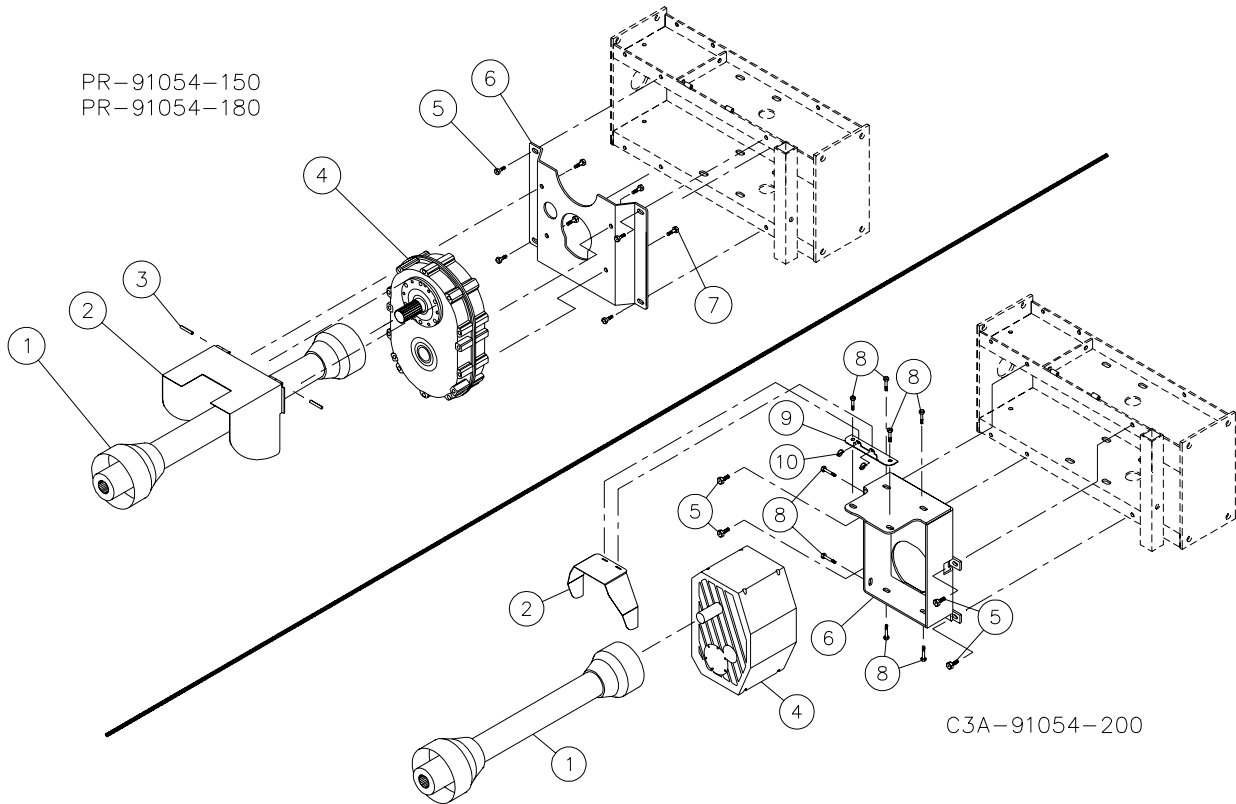

REF.	PART #	DESCRIPTION	PR-91054-150	PR-91054-180	C3A-91054-200	QTY
1	9599	P.T.O. V90 1 3/8"-21 splines	opt.	opt.	opt.	
1	9604	P.T.O. V90 1 3/4"-20 splines	opt.	opt.	opt.	
2	110-12961	Hinged P.T.O. shroud	1	1	-	
2	130-26781	Hinged P.T.O. shroud (if equipped with a 3 gears reduction gear box)	-	-	1	
3	Std.	Roll pin 5/16" x 2" lg	2	2	-	
4	9575	Reduction gear box - 3 chains 1000/540 150 HP	1	-	-	
4	9609	Reduction gear box - 5 chains 1000/540 180 HP	-	1	-	
4	9621	Reduction gear box - 3 gears 1000/540 200 HP	-	-	1	
5	300-40310	Bolt 1/2" NC x 1 1/2" lg + nylon locknut & flat washer	4	4	4	
6	130-19521	Mounting plate for 3 or 5 chains reduction gear box on P-982TRC-150...	1	1	-	
6	110-19611	Mounting box for 3 gears reduction gear box on P-982TRC-150	-	-	1	
7	300-40280	Bolt 1/2" NC x 1 1/4" lg + lock washer	4	4	-	
8	309-40030	Bolt M16-2.0 x 40 mm pl + spring washer 5/8" & flat washer 5/8"	-	-	8	
9	130-26721	Hinged P.T.O. shroud mounting plate	-	-	1	
10	Std.	Linch pin 1/4" x 1 3/4" lg	-	-	2	

REDUCTION GEAR BOX # 9575 150 HP

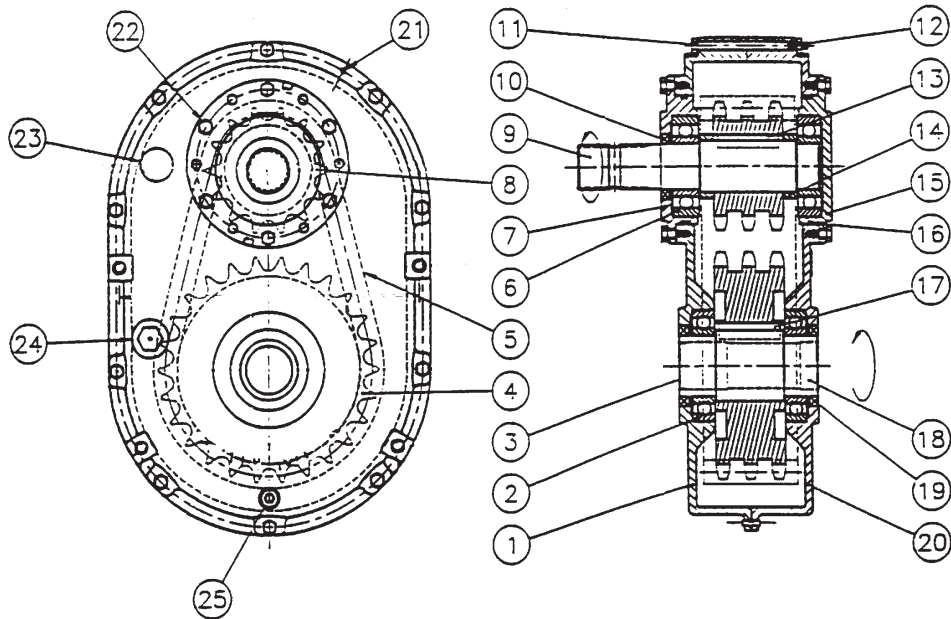

REF.	PART #	DESCRIPTION	QTY
1	9546	Casing with plug	1
2	6212-RS	Bearing 6212	2
3	9547	Seal cover (47 x 7)	1
4	9548	Sprocket 80-3A26	1
5	9549	Chain 80-3 x 36" lg	1
6	6309-RS	Bearing 6309	2
7	9550	Input cover with hole	1
8	9551	Sprocket 80-3A14	1
9	9552	Input shaft 1 3/4"-20 splines	1
10	9553	Oil seal (45x65x8) TC double lips	1
11	Std.	Bolt 5/16" NC x 4 1/2" lg	10
12	Std.	Nut 5/16" NC	10
13	9554	Square key 1/2" x 2 1/2"	1
14	9555	Spacer (2 - 2 3/8 - 0.568)	2
15	9556	Input cover w/o hole	1
16	9557	O-ring AS-248	2
17	9558	Square key 5/8" x 2 1/2"	1
18	9559	Output shaft 1 3/4"-20 splines	1
19	9560	Oil seal (60 x80x10) TC double lips	2
20	9561	Casing w/o plug	1
21	9562	Slotted spring pin 3/16" x 3/4"	2
22	Std.	Bolt 3/16" NC x 3/4" lg	12
23	9563	Air vent 1/2" NPT	1
24	9564	Sight glass 3/4" NPT	1
25	9565	Drain plug 1/2" NPT	1

REDUCTION GEAR BOX # 9609 180 HP

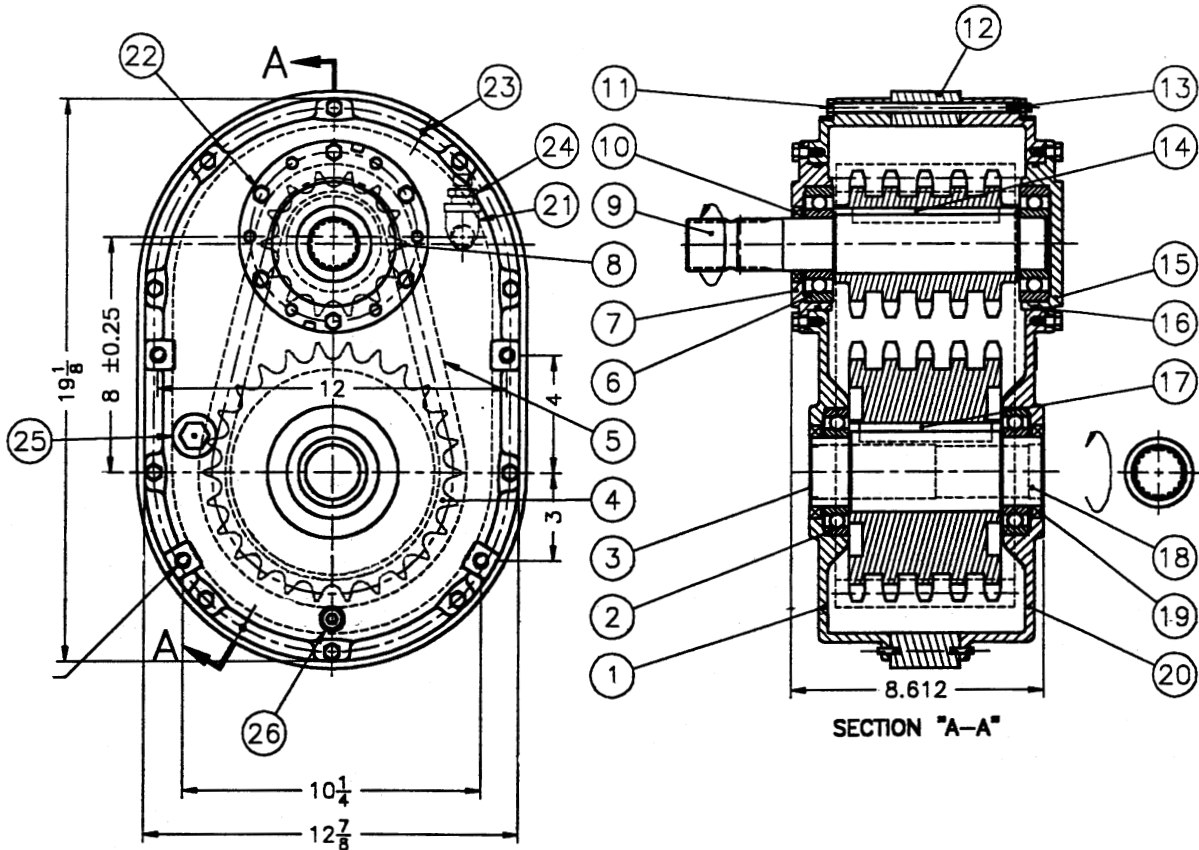

REF.	PART #	DESCRIPTION	QTY
1	9546	Casing with plug	1
2	6212-RS	Bearing 6212	2
3	9547	Seal cover (47 x 7)	1
4	9610	Sprocket 80-5A26	1
5	9611	Chain 80-5 x 36" lg	1
6	6309-RS	Bearing 6309	2
7	9550	Input cover with hole	1
8	9612	Sprocket 80-5C14	1
9	9613	Input shaft 1 3/4"-20 splines	1
10	9553	Oil seal (45 x 65 x 8)	1
11	Std.	Bolt 5/16"-18 UNC x 7	3
12	9614	Spacer	1
13	Std.	Nut 5/16"-8 UNC & lock washer	10
14	9615	Key 1/2" x 5	1
15	9556	Input cover w/o hole	1
16	9557	O-ring AS-248	2
17	9616	Key 5/8" x 4 1/2"	1
18	9617	Output shaft 1 3/4"-20 splines	1
19	9560	Oil seal (60 x 80 x 10) TC double lips	2
20	9561	Casing w/o plug	1
21	9618	Elbow 1/2" 90 deg.	1
22	9563	Air vent 1/2" NPT	1
23	9562	Slotted spring pin 3/16" x 3/4"	2
24	Std.	Bolt 5/16" NC x 3/4" lg & lock washer	12
25	9564	Sight glass 3/4" NPT	1
26	9565	Drain plug 1/2" NPT	1
27	Std.	Bolt 5/16"-18 UNC x 6 3/4" lg	7

10

REDUCTION GEAR BOX # 9621 - 200 HP

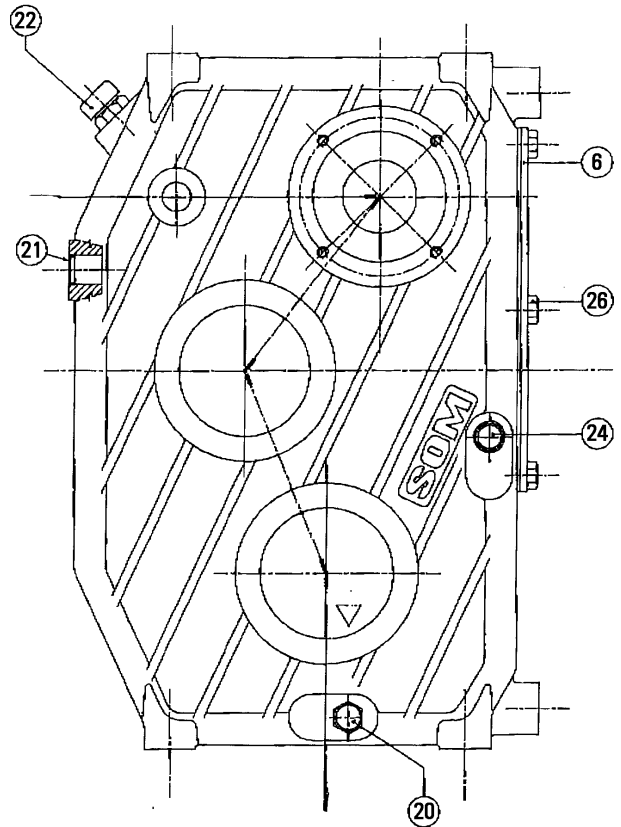
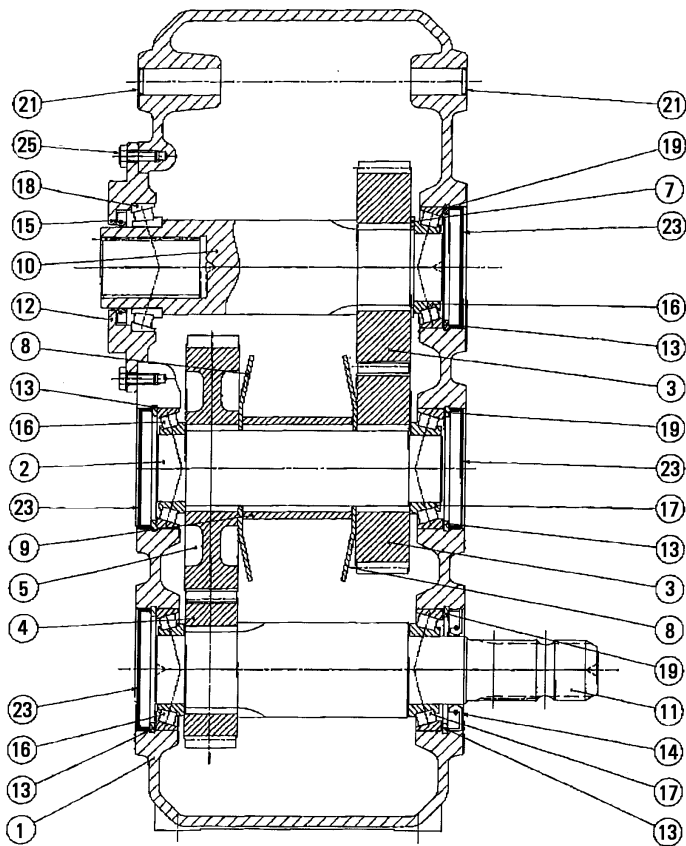

REF.	PART #	DESCRIPTION	QTY
1	9622	Housing	1
2	9623	Shaft	1
3	9624	Ring gear	2
4	9625	Pinion	1
5	9626	Ring gear	1
6	9627	Cover	1
7	9628	Spacer	1
8	9629	Spacer	2
9	9630	Shim	1
10	9631	Output shaft	1
11	9632	Input shaft	1
12	9633	Cover	1
13	9634	Internal snap ring D.90	5
14	9635	Oil seal (50x90x10)	1
15	9636	Oil seal (60x85x8)	1
16	30210-A	Taper roller bearing	3
17	32210-A	Taper roller bearing	2
18	32012X	Taper roller bearing	1
19	9637	Shim kit	3
20	9638	Plug 3/8G	1
21	9639	Plastic plug 20x4	3
22	9640	Plug 1/2G	1
23	9641	Plastic plug 90x10	4
24	9642	Oil level sight glass 3/8G	1
25	9643	Bolt M8x22	8
26	9644	Bolt M10x16	6

P.T.O. SHAFT # 9598, 9599 & 9604

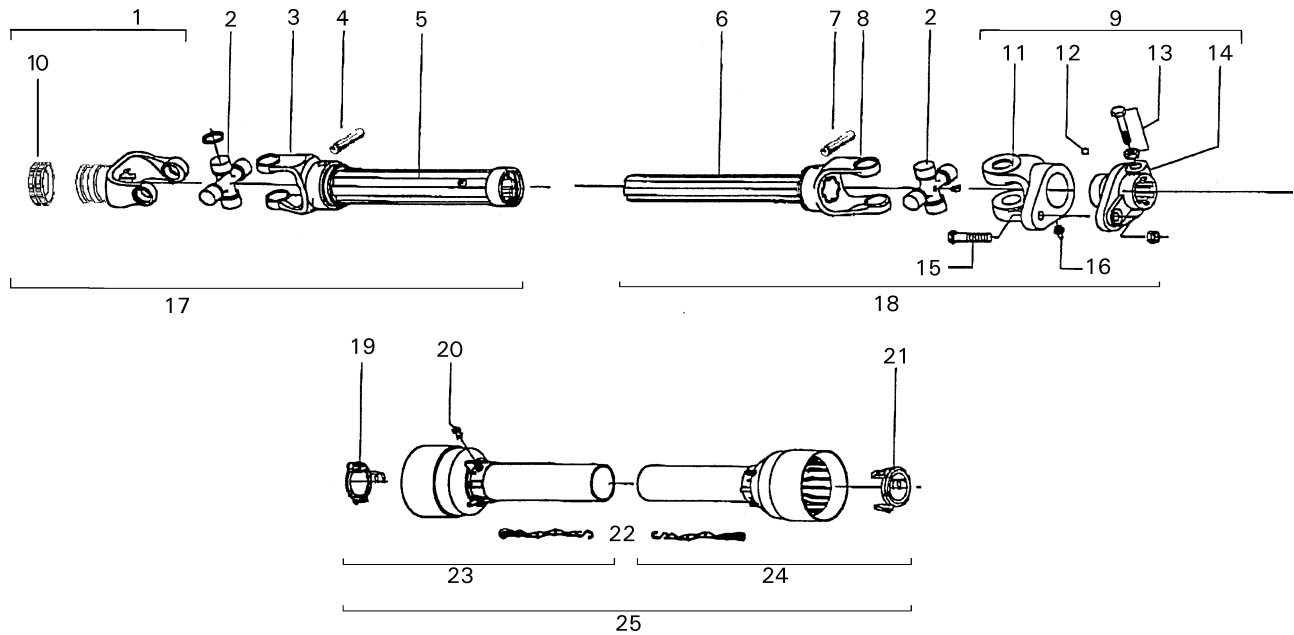

REF.	PART #	DESCRIPTION	9598	9599	9604
1	9481	Yoke with hole 1 3/8" - 6 splines with lock yoke (540 RPM)	1	-	-
1	9482	Yoke with hole 1 3/8" - 21 splines with lock yoke (1000 RPM)	-	1	-
1	9483	Yoke with hole 1 3/4" - 20 splines with lock yoke (1000 RPM)	-	-	1
2	9477	U-joint	2	2	2
3	9600	Yoke for outer tube	1	1	1
4	9210	Stopper for tube	1	1	1
5	9601	Outer tube	1	1	1
6	9602	Inner tube	1	1	1
7	9210	Stopper for tube	1	1	1
8	9603	Yoke for inner tube	1	1	1
9	9476	Safety shear yoke	1	1	1
10	8363	collar kit	1	1	-
10	8364	collar kit	-	-	1
11	9487	Yoke and shearplate M12 x 65	1	1	1
12	9205	Ball 5/16" dia.	24	24	24
13	9461	Bolt + nut M12x1.25x75	2	2	2
14	9486	Adaptor	1	1	1
15	9207	Bolt + nut M12x65	1	1	1
16	8071	Grease fitting	1	1	1
17	9607	P.T.O. section, outer part, without protector, 1 3/8" - 6 splines	1	-	-
17	9607-1	P.T.O. section, outer part, without protector, 1 3/8" - 21 splines	-	1	-
17	9607-2	P.T.O. section, outer part, without protector, 1 3/4" - 20 splines	-	-	1
18	9608	P.T.O. section, inner part, without protector	1	1	1
19	9460	Bearing ring	1	1	1
20	8109	Stopper	6	6	6
21	9459	Bearing ring	1	1	1
22	8308	Safety chain	2	2	2
23	9220	Outer shield	1	1	1
24	9221	Inner shield	1	1	1
25	9222	Complete shield	1	1	1

GEAR BOX # 9307 (T279)

170-05031.tif

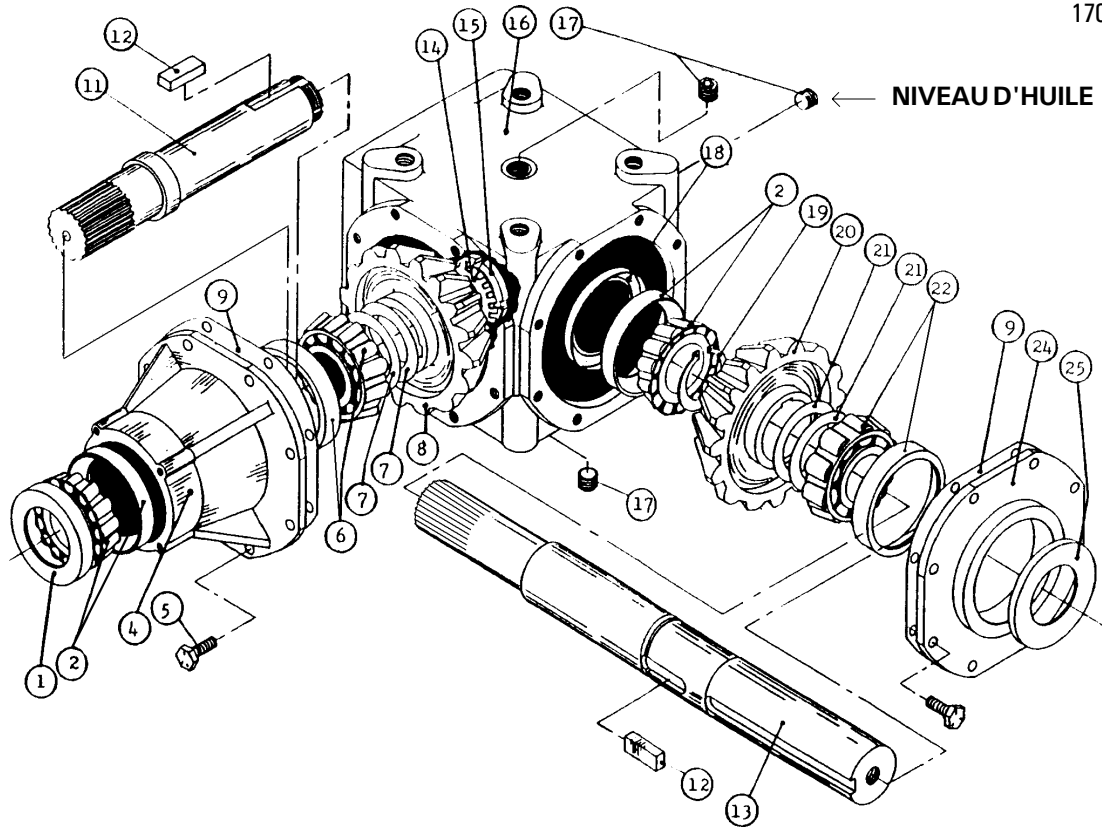

REF.	PART #	DESCRIPTION	QTY
1	6314	Oil seal 52 x 85 x 10	1
2	30209-A	Bearing: cone & cup	2
4	6318	Extension	1
5	6319	Bolt M10 x 22	16
6	32209-A	Bearing: cone & cup	1
7	6321	Shim	2
8	6322	Gear Z21	1
9	- - -	Use silicone caulking	-
11	6325	Side shaft Z20 (1 3/4" - 20 splines)	1
12	6326	Key B14 x 9 x 40	2
13	9345	Impeller shaft (2" & 1 3/4" - 20 splines)	1
14	6328	Spring washer	1
15	6329	Lock nut M40 x 1.5 H9	1
16	6330	Casing	1
17	6331	Plug 3/8" gas	3
18	6332	Dust excluder 45 x 72 x 8	1
19	6333	External circlip 50 UNI7435	1
20	6334	Gear Z21	1
21	6335	Shim	2
22	30210-A	Bearing: cone & cup	1
24	6338	Cover	1
25	6339	Oil seal 50 x 72 x 8	1

CYLINDER 25TR08

15050

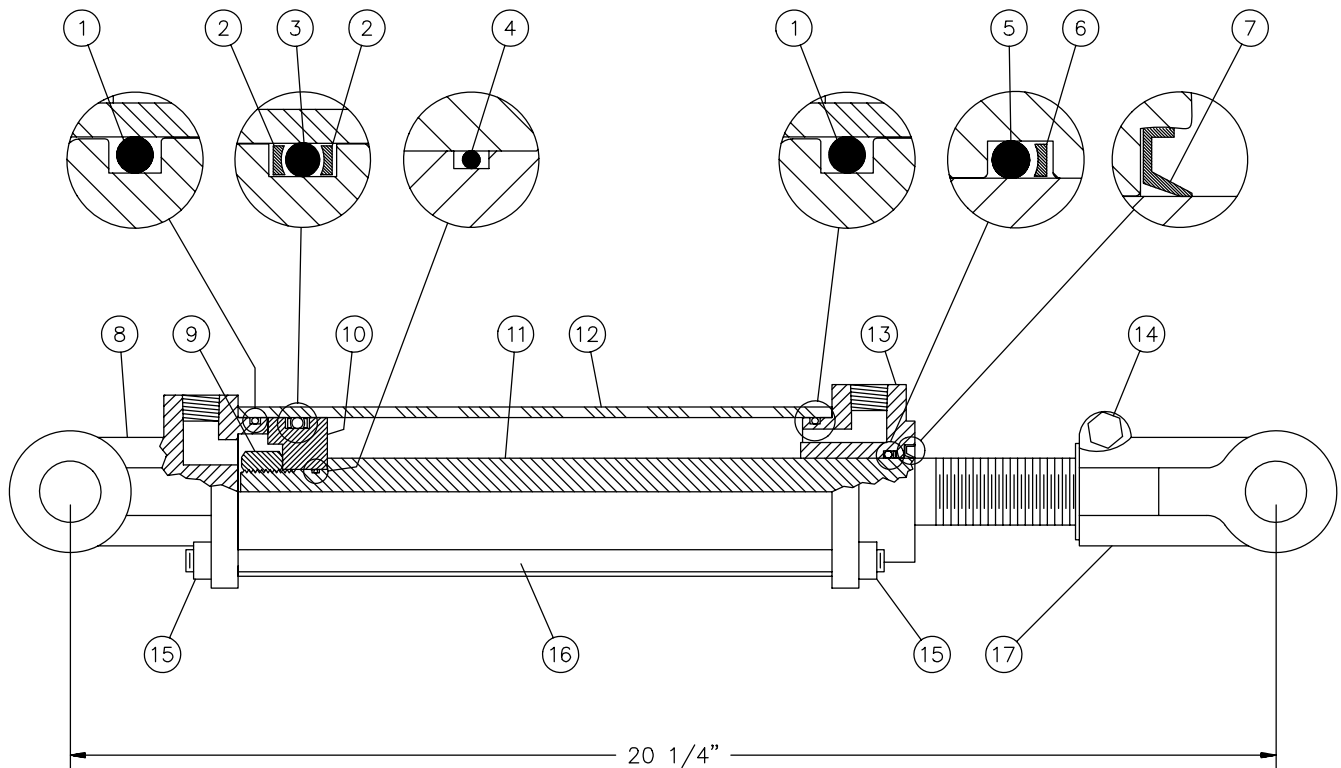

REF.	PART #	DESCRIPTION	QTY
1	See RK25TR	O-ring 1/8" x 2 1/4" x 2 1/2"	2
2	See RK25TR	Back-up 2 1/2" o.d. x 3/16 ø	2
3	See RK25TR	O-ring 3/16" x 2 1/8" x 2 1/2"	1
4	See RK25TR	O-ring 1/16" x 5/8" x 3/4"	1
5	See RK25TR	O-ring 1/8" x 1 1/8" x 1 3/8"	1
6	See RK25TR	Back-up 1 3/8" o.d. x 1/8" ø	1
7	See RK25TR	Wiper 1 1/8" i.d. x 1 5/8" o.d.	1
8	492401	Yoke (for tube 2 1/2")	1
9	Std.	Nut 3/4" NF	1
10	4924-31	Piston 2 1/2" ø	1
11	492028	Piston rod 1 1/8"	1
12	491668	Cylinder body 2 1/2" ø	1
13	492421	Head (for 2 1/2" tube)	1
14	Std.	Bolt 3/8" NC x 2 1/4" + nut	1
15	Std.	Nut 3/8" NC	8
16	Std.	Threaded rod 3/8" NC	4
17	458599	Yoke (for 1 1/8" rod)	1
NI*	8183	Pin 1" ø + cotter pin	2
NI*	RK25TR	Repair kit for cylinder 2 1/2" (includes # 1, 2, 3, 4, 5, 6, & 7)	1

*NI = NOT ILLUSTRATED

CYLINDER 15PC32

170-04361

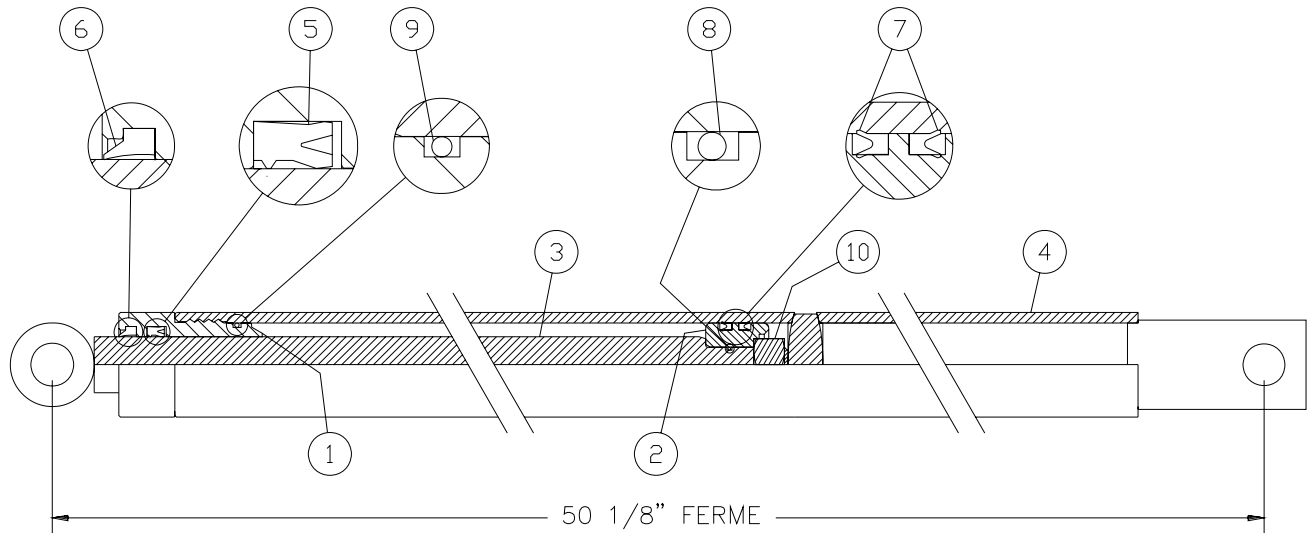

REF.	PART #	DESCRIPTION	QTY	
			15PC32D	15PC32G
1	150-06561	Head 1 1/2" dia.	1	1
2	150-06571	Piston 1 1/2" dia.	1	1
3	110-26561	Piston rod 1" dia.	1	1
4	110-29631	Cylinder body 1 1/2" dia. (15PC32D)	1	-
4	110-29632	Cylinder body 1 1/2" dia. (15PC32G)	-	1
5	DRTU-18-1.00-31	«U» seal 3/16" x 1" x 1 3/8"	1	1
6	ST-100	Wiper 3/16" x 1" x 1 1/8"	1	1
7	DSU12-1.25-18	«U» seal 3/16" x 1 1/4" x 1 1/2"	2	2
8	OR-014	O-ring 1/16" x 1/2" x 5/8"	1	1
9	OR-125	O-ring 3/32" x 1 5/16" x 1 1/2"	1	1
10	336-44000	Nut 5/8" NC	1	1
NI*	9689	Repair kit (includes # 5, 6, 7, 8 & 9)	1	1

*NI = NOT ILLUSTRATED

HYDRAULIC MOTOR # MLH315

CUSHION VALVE H110

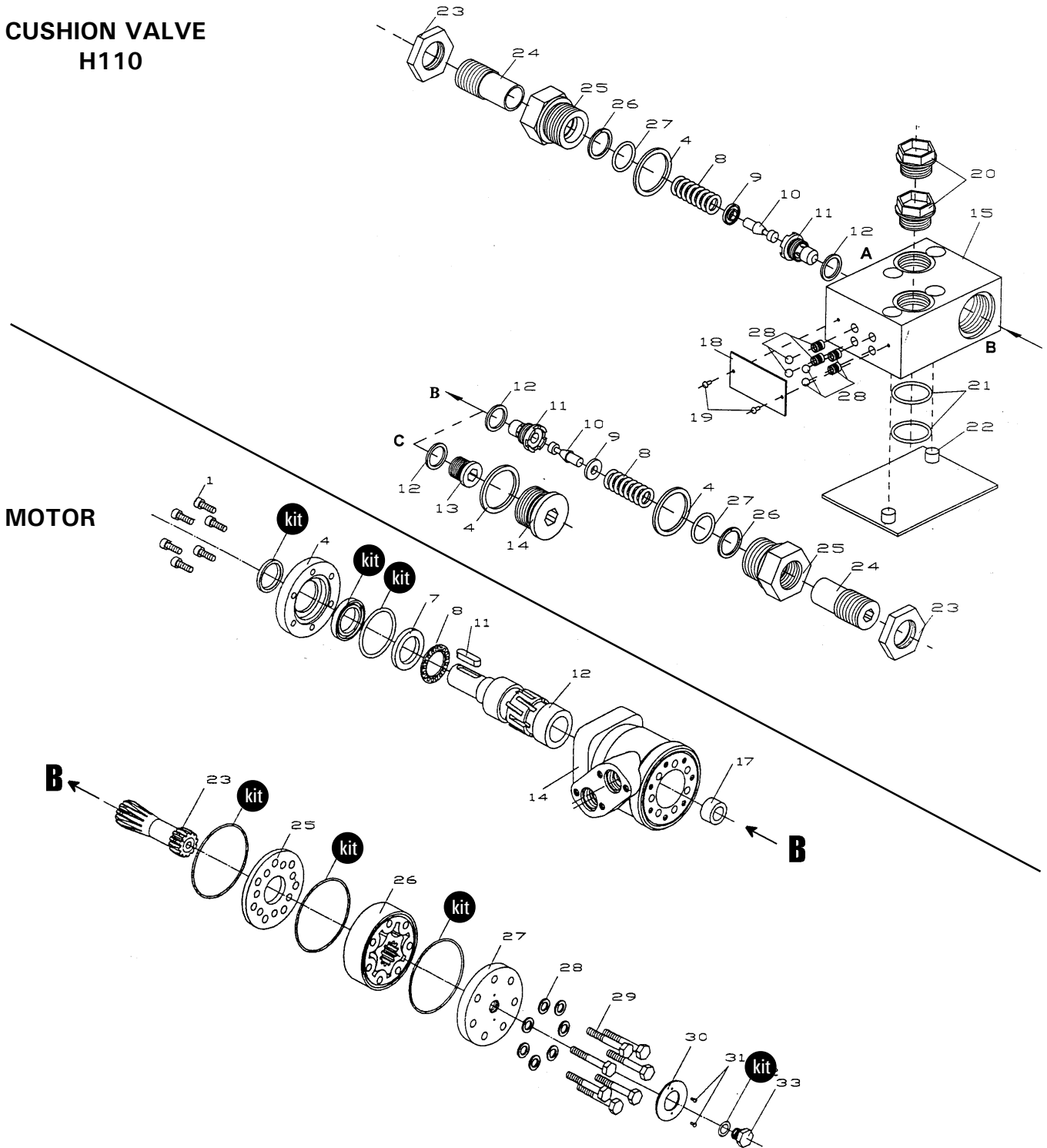







10





REF.	PART #	DESCRIPTION	QTY
kit	8368	Set of seals.....	1
11	8369	Key for "Orbit" motor.....	1

TORQUE CHART

TORQUE SPECIFICATION TABLE

Thread UNC and UNF		Grade 2 				Grade 5   				Grade 8*   			
Bolt size		Torque				Torque				Torque			
Inches	mm	Pound feet min.	max.	Newton meters min.	max.	Pound feet min.	max.	Newton meters min.	max.	Pound feet min.	max.	Newton meters min.	max.
1/4	6.35	5	6	6.8	8.13	9	11	12.2	14.9	12	15	16.3	30.3
5/16	7.94	10	12	13.6	16.3	17	20.5	23.1	27.8	24	29	32.5	39.3
3/8	9.53	20	23	27.1	31.2	35	42	47.5	57.0	45	54	61.0	73.2
7/16	11.11	30	35	40.7	47.4	54	64	73.2	86.8	70	84	94.9	113.9
1/2	12.70	45	52	61.0	70.5	80	96	108.5	130.2	110	132	149.2	179.0
9/16	14.29	65	75	88.1	101.6	110	132	149.2	179.0	160	192	217.0	260.4
5/8	15.88	95	105	128.7	142.3	150	180	203.4	244.1	220	264	298.3	358.0
3/4	19.05	150	185	203.3	250.7	270	324	366.1	439.3	380	456	515.3	618.3
7/8	22.23	160	200	216.8	271.0	400	480	542.4	650.9	600	720	813.6	976.3
1	25.40	250	300	338.8	406.5	580	696	786.5	943.8	900	1080	1220.4	1464.5
1 1/8	25.58	-	-	-	-	800	880	1084.8	1193.3	1280	1440	1735.7	1952.6
1 1/4	31.75	-	-	-	-	1120	1240	1518.7	1681.4	1820	2000	2467.9	2712.0
1 3/8	34.93	-	-	-	-	1460	1680	1979.8	2278.1	2380	2720	3227.3	3688.3
1 1/2	38.10	-	-	-	-	1940	2200	2630.6	2983.2	3160	3560	4285.0	4827.4

* Thick nuts must be used with grade 8 bolts.

Size of screw	Thread	Pitch (mm)	Grade 4T  				Grade 7T 				Grade 8T  			
			Torque				Torque				Torque			
			Pound feet min.	max.	Newton meters min.	max.	Pound feet min.	max.	Newton meters min.	max.	Pound feet min.	max.	Newton meters min.	max.
M6	UNC	1.00	3.6	5.8	4.9	7.9	5.8	9.4	7.9	12.7	7.2	10	9.8	13.6
M8	UNC	1.25	7.2	14	9.8	19	17	22	23	29.8	20	26	27.1	35.2
M10	UNC	1.5	20	25	27.1	33.9	34	40	46.1	54.2	38	46	51.5	62.3
M12	UNC	1.75	28	34	37.9	46.1	51	59	69.1	79.9	57	66	77.2	89.4
M14	UNC	2.0	49	56	66.4	75.9	81	93	109.8	126	96	109	130.1	147.7
M16	UNC	2.0	67	77	90.8	104.3	116	130	157.2	176.2	129	145	174.8	196.5
M18	UNC	2.0	88	100	119.2	136	150	168	203.3	227.6	175	194	237.1	262.9
M20	UNC	2.5	108	130	146.3	176.2	186	205	252	277.8	213	249	288.6	337.4
M8	UNF	1.0	12	17	16.3	23	19	27	25.7	36.6	22	31	29.8	42
M10	UNF	1.25	20	29	27.1	39.3	35	47	47.4	63.7	40	52	54.2	70.5
M12	UNF	1.25	31	41	42	55.6	56	68	75.9	92.1	62	75	84	101.6
M14	UNF	1.5	52	64	70.5	86.7	90	106	122	143.6	107	124	145	168
M16	UNF	1.5	69	83	93.5	112.5	120	138	162.6	187	140	158	189.7	214.1
M18	UNF	1.5	100	117	136	158.5	177	199	239.8	269.6	202	231	273.7	313
M20	UNF	1.5	132	150	178.9	203.3	206	242	279.1	327.9	246	289	333.3	391.6

Use the above torques when special torque is not given.

NOTE: These values apply to fasteners as received from supplier, dry, or when lubricated with normal engine oil. They do not apply if extreme pressure lubricants are used.

WARRANTY

12

PRONOVOST warrants this product to the initial purchaser for the period of one year from the date of purchase against defects in materials and workmanship.

We will replace or repair defective parts free of charge if they are returned to our plant in St-Tite, Quebec, Canada.

Transportation charges are the responsibility of the customer. This warranty is not transferable.

Hydraulic cylinders and motors are covered by the manufacturer of these items.

The PTO shafts are warranted by the manufacturer and cover **only** defects in material and workmanship, and is conditional to recommended use and installation only.

All PRONOVOST spare parts purchased are covered by a three (3) month warranty.

This warranty becomes void and nul if the equipment is modified, breaks down as the result of an accident, is not operated according to manufacturer's recommendations, damaged by negligence or if maintenance has not been carried out as specified.

Our obligation is limited to the replacement or repair of the defective part. PRONOVOST accepts no responsibility for direct or indirect consequential damages of any kind.

Ce manuel est aussi disponible en français.
Veuillez téléphoner.



INNOVATION - EXCELLENCE

LES MACHINERIES PRONOVOST INC.
260, route 159,
Saint-Tite, Quebec, Canada, G0X 3H0
Tel.: (418) 365-7551, Fax: (418) 365-7954
www.pronovost.qc.ca