



**OPERATOR'S / PARTS
MANUAL**



Industrial snowblower
Model
P-1022TRC-200

VISIT OUR WEBSITE



www.pronovost.qc.ca

Copyright © Les Machineries Pronovost Inc., 2007

All rights reserved.
Printed in Canada.

TABLE OF CONTENTS

Section	Item	Page
1	Introduction	5
2	Safety	6
	General Safety	6
	Safety in operation	6
	Safety with maintenance	7
	Safety in transport	7
	Safety in storage	7
3	Decals	8
	Safety Decals	8
	Maintenance Decals	10
4	Assembly	12
	General assembly	12
5	Start-up	13
	Basic start-up Procedures	13
6	Maintenance	14
7	Storage	16
8	Trouble Shooting	17
9	Specifications	19
10	Parts List	20
	Snowblower P-1022TRC-200	20
	Industrial Chute PC-IND	24
	Hydraulic Telescopic Chute PCTH-IND	26
	Semi-industrial Chute PSIG-92104	28
	Hydraulic Telescopic Chute PCTHG-92104	30
	Hydraulic Lateral Blade	32
	Reduction Gear Box # 9621	33
	P.T.O. # 9599 & 9604	34
	Gear Box # 9597	35
	Cylinder 25TR08	36
	Cylinder 15PC32	37
	Hydraulic Motor MLH 315	38
11	Torque chart	39
12	Warranty	40

INTRODUCTION

CONGRATULATIONS!

Thank you for choosing PRONOVOST. We are confident this equipment will meet your requirements in terms of quality, performance and reliability.

This manual was prepared to assist you in the safe operation of your new Snowblower. It contains important information which will help you achieve excellent returns with your Snowblower for years to come.

Please read this manual completely before operating your Snowblower and keep it for future reference.

Before starting the machine, you or any other person who will be operating the Snowblower must familiarize yourself with the safety recommendations and the operating instructions. Please read carefully and be sure to understand and follow all recommendations and procedures.

In this manual, the right and left sides are identified as shown on Figure 1.

If you require additional information on your Snowblower, please contact your PRONOVOST Dealer.

NOW take a moment to enter the model, serial number and the date of purchase of your Snowblower in the space provided.

When ordering parts from your Dealer, please refer to these numbers for a fast and efficient service. Use PRONOVOST parts for replacement.

The model and serial numbers are on the name plate shown on Fig. 1.

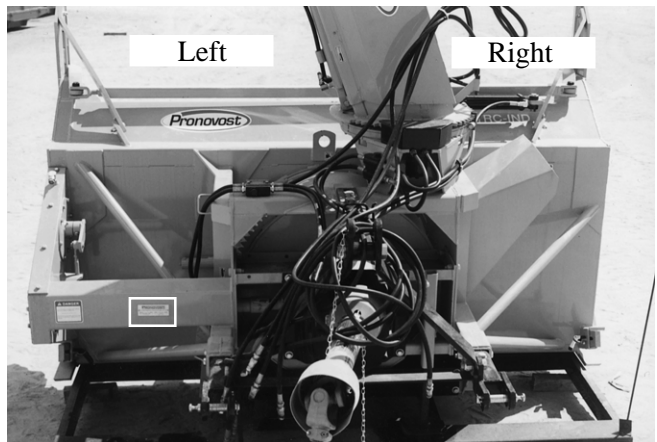

Figure 1

MODEL: _____ ✍

SERIAL NO: _____ ✍

DATE OF PURCHASE: _____ ✍

SAFETY

GENERAL SAFETY

2

WHEN YOU SEE THIS SYMBOL



ATTENTION!

**BE ALERT
YOUR SAFETY IS INVOLVED**

This symbol «SAFETY ALERT» is used in this manual and on the safety decals on the Snowblower. It warns you of the possibility of danger. Carefully read, understand and follow all safety recommendations before operating the Snowblower.

- 1) Careful operation is the best assurance against accidents. Carefully read this manual and follow all recommendations before operating your Snowblower. It is the owner's responsibility to make sure that anyone who will operate the Snowblower will read this manual before operating the equipment.
- 2) Familiarize yourself with all controls and always be ready to stop the Snowblower quickly in case of emergency.
- 3) Never let a child operate the Snowblower.
- 4) Do not modify the Snowblower. Any non authorized modification may affect the efficiency and/or safety of the equipment and will automatically void the warranty.
- 5) Never operate the Snowblower with defective parts or if damaged in any way. Have it repaired before operating.
- 6) Make sure all fasteners are in place and properly secured or tightened. Refer to torque chart on page 39.
- 7) Avoid wearing loose fitting clothing when working with the Snowblower. These could get entangled in moving parts of the equipment and cause accidents.

- 8) Prolonged exposure to noise may hamper hearing. Protect yourself by wearing adequate protection devices.
- 9) Hydraulic fluids under pressure can damage your skin. Do not use your hands to locate a leak.
- 10) Before the beginning of the snow season, inspect all areas where the Snowblower will be used and remove any object which may cause an accident and/or damage the equipment.
- 11) Never operate your Snowblower in poor visibility or without proper lighting conditions.

SAFETY IN OPERATION

- 1) Be sure there are no obstructions around the equipment and that no one stands near the equipment when in operation.
- 2) Do not operate an engine in a confined or non ventilated area.
- 3) Do not perform any adjustments, cleaning, maintenance or repairs with the engine running. The engine must be stopped and the P.T.O. disengaged. Preferably remove the key from the ignition.
- 4) Wear adequate clothing when working in cold or windy conditions.
- 5) Adjust skid shoes for proper ground clearance of scraper blade, especially in rough terrain or soft ground conditions.
- 6) Before operating, make sure the P.T.O. is properly installed and secured.
- 7) Before starting-up the Snowblower, make sure the auger and drum areas are free of ice.
- 8) Put P.T.O. control in neutral position before starting engine.
- 9) Keep hands, feet and clothing away from moving parts of the Snowblower. Stay away from the discharge chute.

SAFETY (cont'd)

- 10) Before unplugging the chute, always disengage the P.T.O., stop the engine and relieve all hydraulic pressures.
- 11) Do not operate in excessive inclined conditions. Be careful when turning in slopes.
- 12) Never operate your Snowblower with missing guards or without protective devices in place.
- 13) Do not operate your Snowblower near buildings, windows or other vehicles without prior and proper adjustment of the chute deflector.
- 14) Never aim discharge chute towards people or animals. This may cause serious injuries.
- 15) Always reduce operating speed in slippery conditions.
- 16) Be careful when backing-up, make sure you have good visibility.
- 17) Always be on the lookout for objects which may enter the snowblower.
- 18) If undue vibrations are felt, disengage the P.T.O., stop the motor and look for the cause of the vibration. Vibration is usually the indication of a problem.
- 19) At the end of the operation, disengage the P.T.O., lower the Snowblower, put transmission in neutral, apply parking brake, stop engine and remove the key from the ignition.

SAFETY WITH MAINTENANCE

- 1) Perform the Snowblower maintenance according to recommendations contained in this manual.

- 2) Stop engine and relieve all hydraulic pressures before doing inspection, maintenance or repairs.
- 3) Never perform any work under the Snowblower while it is supported only by the tractor's hydraulic system. It must be completely supported by wooden blocks or other safe means.

SAFETY IN TRANSPORT

- 1) On public roads, use proper safety lights and check local regulations.
- 2) Be alert while driving on the road. Never carry passengers.
- 3) Always disengage P.T.O. while moving from one area of work to another.
- 4) It is recommended to use both brake pedals simultaneously for better control.
- 5) The recommended road speed should be such as to maintain full control over steering and braking.
- 6) Be careful while backing up, make sure you have good visibility.

SAFETY IN STORAGE

- 1) Provide adequate supports to prevent any accidental overturning of the Snowblower.
- 2) Do not let children play in the area where the Snowblower is stored.

2

DECALS

SAFETY DECALS

The safety decals are affixed wherever special safety precautions are indicated. Locate them on the machine and read them carefully. If a decal is damaged, lost or illegible, install a new one. The following photos indicate where each one must be installed.

3



Figure 3

! ATTENTION

- 1- FOR SAFE OPERATION, FOLLOW OPERATING INSTRUCTIONS IN OPERATOR'S MANUAL.
- 2- KEEP HANDS, FEET AND CLOTHINGS AWAY FROM POWER DRIVEN PARTS.
- 3- STOP ENGINE BEFORE LEAVING THE EQUIPMENT.
- 4- MACHINE HAS TO BE COMPLETELY STOPPED BEFORE STARTING TO ADJUST OR LUBRICATE.
- 5- KEEP PEOPLE AND PETS AT SAFE DISTANCE FROM MACHINE.
- 6- KEEP ALL GUARDS AND SHIELDS IN PLACE.

- 1- POUR UN FONCTIONNEMENT SÉCURITAIRE SUIVRE LES INSTRUCTIONS DANS LE MANUEL D'OPÉRATION.
- 2- GARDER LES MAINS, PIEDS ET VÊTEMENTS ÉLOIGNÉS DES ÉLÉMENTS MOBILES OU ROTATIFS.
- 3- AVANT DE QUITTER LA MACHINE ARRÊTER LE MOTEUR.
- 4- ARRÊTER COMPLÈTEMENT LA MACHINE POUR EFFECTUER L'ENTRETIEN ET L'AJUSTEMENT.
- 5- GARDER LES GENS ET LES ANIMAUX À UNE DISTANCE SÉCURITAIRE.
- 6- GARDER TOUS LES ÉCRANS PROTECTEUR EN PLACE.

PA 93-01

Figure 2
Decal A

Part no.: A102

! DANGER

TO AVOID SERIOUS INJURIES, KEEP CLEAR OF EQUIPMENT WHILE IN OPERATION.

POUR ÉVITER DES BLESSURES GRAVES SE TENIR LOIN DE CET ÉQUIPEMENT LORSQU'IL EST EN MARCHÉ.

PD 93-03

Figure 4
Decal B

Part no.: A101

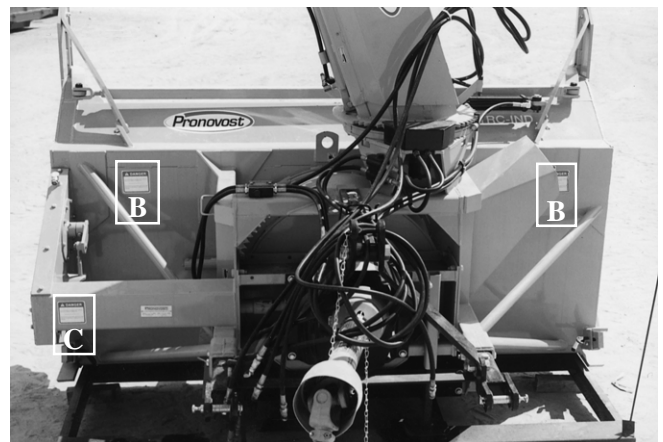

Figure 5

DECALS (cont'd)

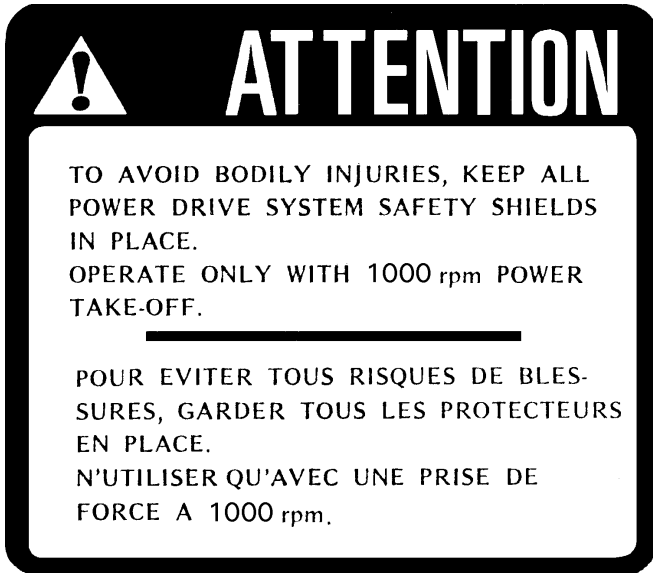

Figure 6
Decal C

Part no.: A112



Figure 7
Decal D

Part no.: A103

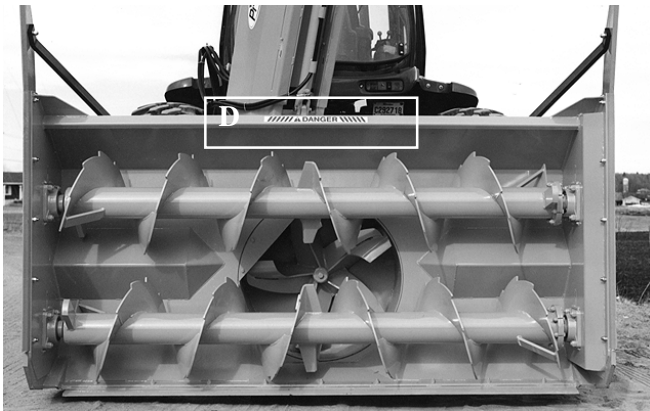

Figure 8

Decal E in Fig. 9 is located directly on the P.T.O. shaft. It is not visible when the safety shield is in place. It must never be visible when you operate the equipment.



Figure 9
Decal E

Part no.: A108

3

DECALS (cont'd)

3

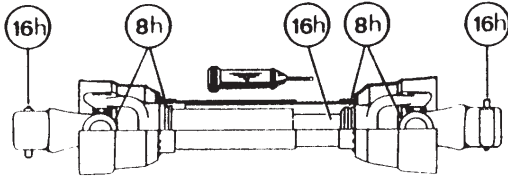

Figure 10
Decal F

Part no.: A 109

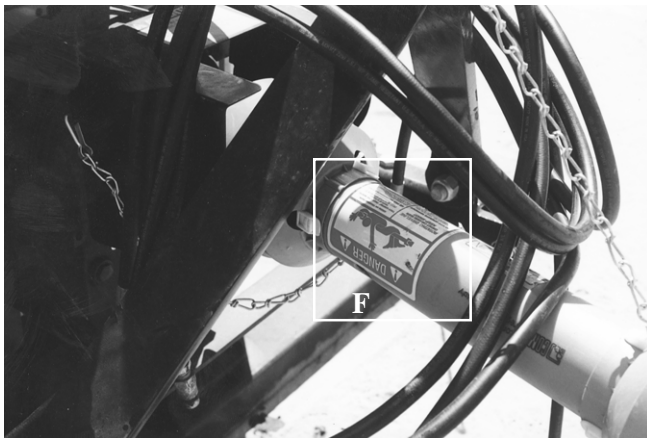

Figure 11

MAINTENANCE DECALS

The maintenance decals indicate the points requiring lubrication. Refer to maintenance section for more details.

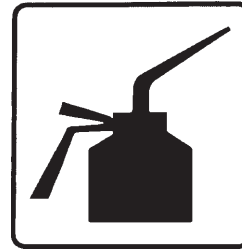

Figure 12

Part no.: A 105



Figure 13

Part no.: A 106



Figure 14
Decal G

Part no.: A104



Figure 15

DECALS (cont'd)

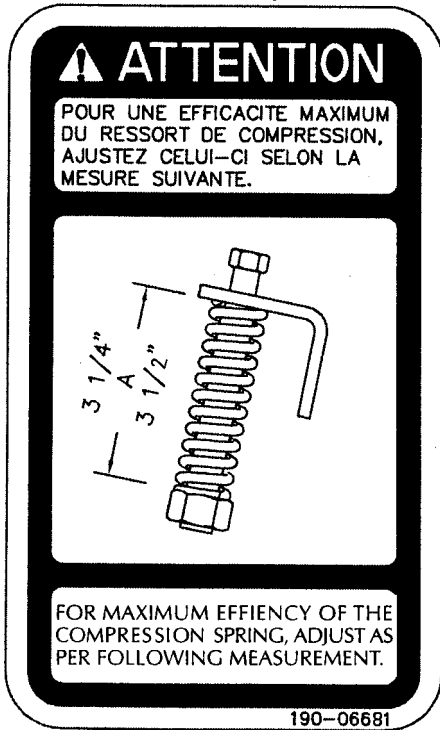

Figure 16
Decal H

Part no.: 190-06681

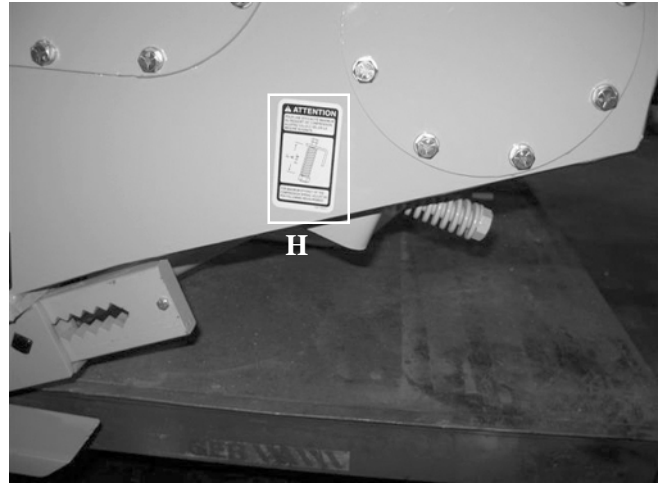

Figure 17

3

ASSEMBLY



Figure 18

4

ASSEMBLY

- 1) The Snowblower is shipped partly assembled.
- 2) Install P.T.O. shaft and place the shear pin end on the Snowblower side. Then attach safety shield support chain as shown (Fig. 18). **WARNING:** The telescoping tubes of the drive shaft must never be allowed to bottom out while maintaining a minimum overlap of 6 inches.



Figure 19

STARTING-UP

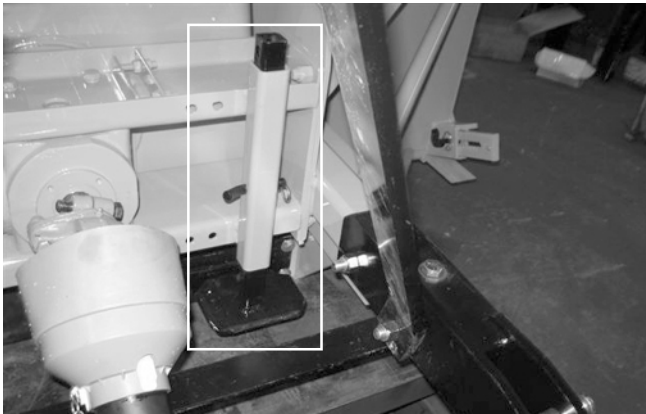

Figure 20

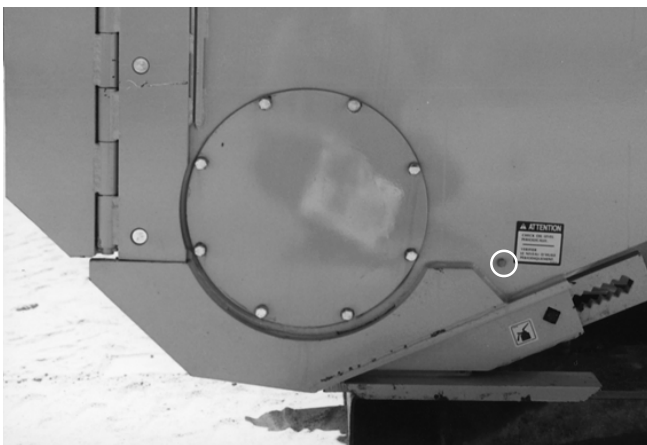

Figure 21



Figure 22

START-UP PROCEDURES

- 1) Check oil level in gearbox and in speed reducer. Adjust to required oil level as per drawing in Parts List section. Use SAE 80W90 oil.
- 2) Lubricate all points with a good quality multipurpose grease.
- 3) Check chain take-up adjustment. The spring maintaining the tension must be compressed to a length between 3 1/4" and 3 1/2".
- 4) Verify for adequate tightness of all fastening devices. Refer to torque chart on page 39.
- 5) Adjust skid shoes according to ground conditions (Fig. 19).
- 6) Following the installation of the Snowblower on the tractor, **do not forget** to lift the storage support (Fig. 20).
- 7) Make sure of a 1000 RPM input to your snowblower.
- 8) Check oil level in auger drive chain box (Fig. 21). Fill to level of plug. Use SAE 80W90 oil.
- 9) Check impeller adjustment. The tip of the blades should be approximately 1/8" to 3/16" from the discharge wall of the drum. If necessary, adjust with the take-up screws provided (Fig. 22).
- 10) In order to avoid damaging your snowblower, adjust the speed of descent of your 3 point hitch to prevent striking the ground too hard.
- 11) Adjust the hydraulic flow in order to have a good control of the rotation speed of the chute.

MAINTENANCE

- 1) Wipe off all grease fittings with a clean cloth before adding grease in order to avoid injecting dirt and sand.
- 2) Repair or replace damaged grease fittings.
- 3) Lubricate all grease fittings every 10 hours of operation.
- 4) Oil drive chain every 8 hours of operation.
- 5) Lubricate P.T.O. shaft as indicated below:

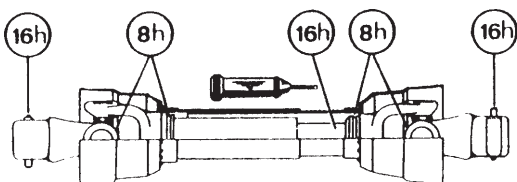

Pull out the P.T.O. And lubricate between the two tubes with low temperature grease.

- 6) Check oil level in gear box once a month. Adjust to required oil level as per drawing in Parts List section. Use SAE 80W90 oil.
- 7) Check oil level in auger drive chain box once a month. Fill to level plug. Use SAE 80W90 oil.
- 8) Check tension of drive chain every 24 hours of operation and adjust if necessary.
- 9) Check for tightness of bearing collars every 48 hours of operation.
- 10) Change gearbox oil once a year. Adjust to required oil level as per drawing in Parts List section. Use SAE 80W90 oil.

- 11) Check all nuts and bolts once a year. If necessary use torque chart on page 39.
- 12) Standard scraper blades are reversible. Reverse when one edge is worn out.
- 13) For the auger drive shaft, always use a grade 5 shear bolt.
- 14) For the PTO shaft, always use a grade 10.9 shear bolt at 540 RPM or a grade 8.8 shear bolt at 1000 RPM.
- 15) UHMW slides do not require lubrication except at the end of the season in order to prevent corrosion of steel components that are in contact with the UHMW material.

If your snowblower is equipped with the optional speed reducer

- 16) Check oil level in speed reducer once a month. Adjust to required oil level as per drawing in Parts List section. Use SAE 80W90 oil.
- 17) Drain the oil of the speed reducer once a year. Adjust to required oil level as per drawing in Parts List section. Use SAE 80W90 oil.

6

MAINTENANCE ON SPEED REDUCER

Instructions for speed reducer maintenance

This chain box has double functions.

- 1) Reduce angles at both ends of PTO in working position by increasing the input shaft height of 8".
- 2) Increase PTO capacity by increasing speed from 540 RPM to 1000 RPM.

MAINTENANCE ON SPEED REDUCER

- 1) Check oil level in speed reducer once a month. Adjust to required oil level as per drawing in Parts List section. Use SAE 80W90 oil.
- 2) Drain the oil of the speed reducer once a year. Adjust to required oil level as per drawing in Parts List section. Use SAE 80W90 oil.

STORAGE

- 1) Store the Snowblower in a cool, dry place.
- 2) Support the Snowblower with wooden blocks.
- 3) Keep all piston rods in the retracted position. This will assure better protection against the elements.
- 4) Clean your Snowblower.
- 5) Thoroughly inspect all parts of the Snowblower. Replace or repair worn or defective parts.
- 6) Touch-up or repaint if necessary.
- 7) Lubricate all points before storage.

TROUBLESHOOTING

P.T.O. SHAFT

PROBLEM	POSSIBLE CAUSE	CORRECTION
<ul style="list-style-type: none"> - Premature wear of U-joints and/ or bluish color of cross journals. 	<ul style="list-style-type: none"> - Insufficient lubrication. - Excessive working angle. 	<ul style="list-style-type: none"> - Follow lubrication recommendations. - Replace defective U-joints. - Make sure the Snowblower inlet face is perpendicular to the ground and if possible readjust 3-point hitch in order to position the Snowblower further away from tractor.
<ul style="list-style-type: none"> - Gripping or premature wear of telescoping members. 	<ul style="list-style-type: none"> - Too much sliding under load. - Tube overlap too-short: minimum recommended is 6". - Insufficient lubrication. - Contaminants (sand, etc.). 	<ul style="list-style-type: none"> - Avoid raising Snowblower while in operation. - Readjust 3-point hitch in order to position the Snowblower closer to the tractor. - Follow lubrication recommendations. - Replace defective telescopic members.
<ul style="list-style-type: none"> - Damaged or jammed locking pin or bolt. 	<ul style="list-style-type: none"> - Pin or orifice contaminated by sand, ice, etc. - Telescoping members too long, exerting pressure on locking device. 	<ul style="list-style-type: none"> - Clean and grease. - Readjust 3-point hitch in order to position the Snowblower further away from tractor or shorten tubes.
<ul style="list-style-type: none"> - Premature wear of guard tube bearing ring. 	<ul style="list-style-type: none"> - Lack of lubrication. - Wrong installation of guard chain. - Part of the guard in contact with the equipment. 	<ul style="list-style-type: none"> - Follow lubrication instructions. - Adjust chain to prevent interference between guard & equipment. - Replace worn or damaged bearing rings.
<ul style="list-style-type: none"> - Cut or deformed safety guard tubes. 	<ul style="list-style-type: none"> - Tubes in contact with the equipment. 	<ul style="list-style-type: none"> - Eliminate any interference between tubes and equipment or tractor. - Replace damaged tubes.

TROUBLESHOOTING (cont'd)

SNOWBLOWER

PROBLEM	POSSIBLE CAUSE	CORRECTION
- The snow is not being thrown as far as usual.	- Tractor RPM too low. - Gap too wide between impeller blade tip and drum outlet wall. - Insufficient tractor HP.	- Raise P.T.O. speed to a minimum of 540 RPM. - Adjust impeller blades closer to drum outlet (1/8" to 3/16"). - Reduce travel speed.
- Frequent plugging of discharge chute.	- Tractor RPM too low. - Tractor RPM reduced too early with snow still in the Snowblower. - Slippage of PTO clutch mechanism. - Wet snow condition.	- Raise P.T.O. speed to a minimum of 540 RPM. - Make sure the Snowblower is completely empty before reducing RPM, especially on tractors with foot controlled RPM. - Repare clutch. - Reduce travel speed. - Remove the chute access panel.
- The impeller will not turn.	- Shear bolt broken on drive shaft.	- Replace shear bolt.
- The auger will not turn.	- Shear bolt broken on drive shaft. - Shear bolt broken on auger drive shaft. - Broken drive chain.	- Replace shear bolt. - Replace shear bolt. - Fix or replace chain.
- The rotating drum will not turn.	- Ice accumulation. - Wrong hydraulic connections.	- Remove ice. - Check hydraulic connections.
- Rotating drum will not hold it's position when blowing via the spout.	- Cushion valve setting too low. - Tension of the spring in the drum locking mechanism insufficient.	- Reset cushion valve up to 1800 psi (max.) - Increase tension of spring by adding shim(s).
- The chute will not turn.	- Ice accumulation. - Wrong hydraulic connections.	- Remove ice. - Check hydraulic connections.

SPECIFICATIONS

Model	P-1022TRC-200		
Horse power required	125 to 200 HP		
Approximative performance	1000 tons imp. / hour with 160 HP tractor		
Height including telescopic chute	165" extended / 135" retracted		
Height - chute base	52"		
Frame height	56 1/2"		
Lateral blades cutting height	Std: 63 1/2"	CL: 82 3/4"	CLH: 82 3/4"
Working width	102"		
Impeller diameter	37"		
Depth of drum	15"		
Impeller blades	6 replaceable 3/8" carbon steel blades		
Shear bolt	1 for the impeller + 1 for the auger drive		
Size of impeller shaft	2 1/2"		
P.T.O. speed required	1000 RPM		
Reducer	Standard (200 HP at 1000 RPM) 1000/540 RPM (1.86 to 1 ratio)		
Impeller speed	540 RPM		
Number of augers	2 x 20" full flight spiked augers with welded carbon steel teeth		
Auger ball bearing	2" (with ductile flange)		
Drive chain	No. 100HD Reynolds in oil bath		
Replaceable scraper blade	6" x 5/8" carbon steel sharpened		
Adjustable skid shoes	Industrial with carbide sole		
Drum rotation	Hydraulic motor and cushion valve included		
Chute rotation	Hydraulic motor and cushion valve included		
P.T.O. shaft	No. 9 V90 Yoke 1 3/8"-21 splines (for 1000 RPM at PTO drive) Yoke 1 3/4"-20 splines (for 1000 RPM at PTO drive)		
3-point hitch	Category 2		
Frame	Sides	3/8"	
	Back	3/16"	
	Drum	Carbon steel 3/8"	
Weight	4990 lbs (with telescopic chute)		

Design and specifications subject to change without notice.

INDUSTRIAL SNOWBLOWER P-1022TRC-200

170-02079R1

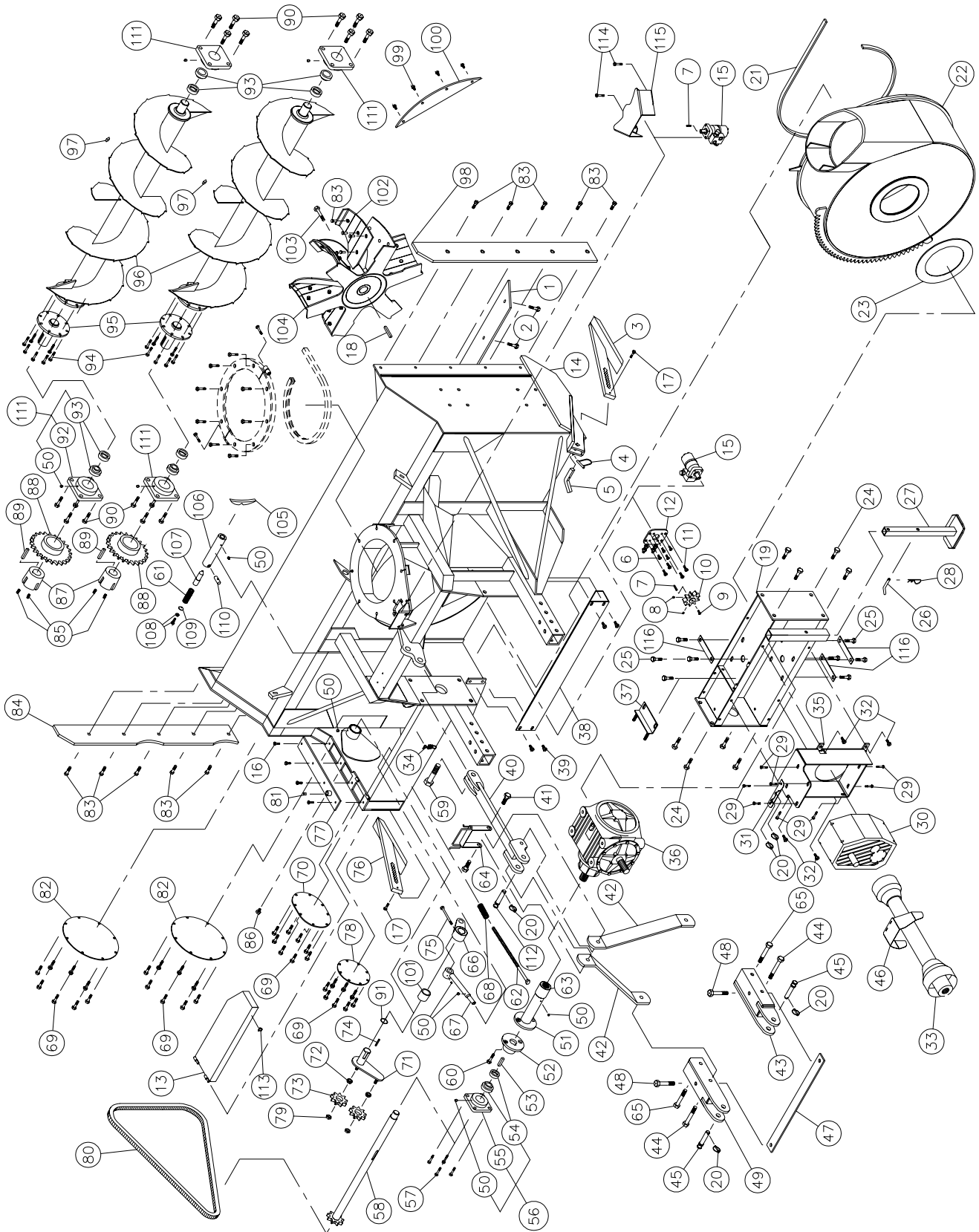

INDUSTRIAL SNOWBLOWER P-1022TRC-200 (cont'd)

REF.	PART #	DESCRIPTION	QTY
1	140-09461	Scraper blade, hardened steel, not reversible, sharpened 5/8" x 6" x 94 7/8 lg .	1
2	319-40340	Plow bolt 1/2" NC x 2" lg + nut & lock washer	10
3	110-32872	Skid shoe (right side)	1
4	8112	Lock pin 1/4"	2
5	140-03361	Skid shoes lock	2
6	300-36250	Bolt 3/8" NC x 1" lg + lock washer	4
7		Key for hydraulic motor (according to motor model)	1
8	323-36160	Hexagonal socket set screw 3/8" NC x 3/8" lg.	2
9	300-32220	Bolt 1/4" NC x 3/4" lg + lock washer	1
10	110-04721	Sprocket 9 teeth	1
11	300-38310	Bolt 7/16" NC x 1 1/2" lg + nylon locknut + flat washer	4
12	110-18441	Orbit motor support + 4 nut 7/16" NC	1
13	110-29271	Drive shaft guard	1
14	120-02885	Frame P-1022TRC-200	1
15	MLH315	Hydraulic motor + cushion valve	1
16	300-38250	Bolt 7/16" NC x 1"lg + lock washer	4
17	300-32310	Bolt 1/4" NC x 1 1/2" lg + nylon locknut	2
18	140-08551	Key for impeller	1
19	110-13182	Gear box support	1
20	Std.	Lynch pin 1/4" x 1 3/4"	5
21	190-07951	U-shaped UHMW 3/8" x 7/8" x 119 23/32" lg	1
22	110-29281	Rotary drum 37" dia.	1
23	130-14641	UHMW flat washer 3/16" x 10" i.d. x 14" o.d.	1
24	300-46340	Bolt 3/4" NC x 2" lg + nylon locknut	8
25	309-40030	Bolt M16 x 12.0 x 30mm + lock washer 5/8" + 6 flat washer	8
26	8220	Storage support pin	1
27	9462	Storage support	1
28	Std.	Hitch pin clip 5/32"	1
29	309-40040	Bolt M16-2.00 x 40 mm lg + lock washer	8
30	9621	Speed reducer 1000/540 - 3 gears - 200 HP	1
31	130-26721	P.T.O. shroud mounting plate	1
32	300-40310	Bolt 1/2" NC x 1 1/2" + nylon locknut & flat washer	4
33	9599	P.T.O. shaft V90 1 3/8"-21 splines	as required
33	9604	P.T.O. shaft V90 1 3/4"-20 splines	as required
34	8374	Adjustable clamp fastener (welded)	1
35	110-19531	Mounting plate for reduction gear box 1000/540	1
36	9597	Gear box	1
37	110-12711	Adjustment plate for gear box + 4 nuts 1/2" NC	1
38	130-48591	Guard for ring gear segment	1
39	300-40280	Bolt 1/2" NC x 1 1/4" lg + nylon locknut + flat washer	4
40	110-29331	Upper hitch	1
41	300-46400	Bolt 3/4" NC x 3" lg + nylon locknut + flat washer 1 1/2" o.d.	2
42	110-17601	3-point side bar	2
43	110-12782	Right lower hitch	1
44	302-46610	Bolt 3/4 NF x 6 1/2" lg + nylon locknut	2
45	9269	Pin category 2	2
46	130-26781	P.T.O. shroud	1
47	140-17611	3-point hitch reinforcement	1
48	300-46550	Bolt 3/4" NF x 5 1/2" lg + nylon locknut	2
49	110-12783	Left lower hitch	1
50	Std.	Grease fitting 1/4-28 straight	10

INDUSTRIAL SNOWBLOWER P-1022TRC-200

REF.	PART #	DESCRIPTION	QTY
51	110-11372	Side shaft & shearplate (long side) + splined adaptor (20 splines)	1
52	110-11361	Side shaft & shearplate (short side)	1
53	140-08541	Key for auger drive shaft & shearplate (short side)	1
54	HC209-28	Bearing 1 3/4" with eccentric collar	1
55	FS209	Ductile flange (4 holes)	1
56	HCFS209-28	Bearing 1 3/4" + ductile flange + 1 grease fitting	1
57	300-44340	Bolt 5/8" NC x 2" lg + nylon locknut	4
58	110-14632	Auger drive shaft 35 9/16" lg	1
59	300-54460	Bolt 1 1/4" NC x 4" lg + nylon locknut	1
60	300-38355	Bolt 7/16" NC x 2 1/4" lg + nylon locknut	1
61	9473	Compression spring	1
62	110-17751	Threaded rod for idler adjustment	1
63	110-13441	Splined adaptor 1 3/4" - 20 (welded)	1
64	110-15201	Hoses support	1
65	302-46580	Bolt 3/4" NF x 6" lg + nylon locknut	2
66	110-17731	Idler (outside part)	1
67	110-17761	Threaded tube for idler adjustment	1
68	9687	Compression spring	1
69	300-36190	Bolt 3/8" NC x 1 1/2" lg + lock washer	32
70	130-12403	Idler cover	1
71	110-17771	Idler (inside part)	1
72	160-02171	Spacer	2
73	9470	Idler sprocket no 100A9H x 3/4"	2
74	140-12161	Idler key	1
75	306-40460	Bolt 1/2" NC x 4" lg GR 12 + nylon locknut	1
76	110-32871	Skid shoe (left side)	1
77	110-13862	Upper chain guard cover	1
78	130-12392	Chain guard cover (left side)	1
79	346-47000	Nylon locknut 3/4" NC thin	2
80	190-07971	Renold chain #100 HD x 120" (96 links)	1
80	59-100 HD	Offset link #100 HD	1
80	26A100 HD	Connecting link #100 HD	1
81	9619	Vent plug 1/2" NPT	1
82	130-12382	Chain guard cover	2
83	319-40310	Plow bolt 1/2" NC x 1 1/2" lg + nut & lock washer	24
84	130-19863	Left lateral blade	1
85	323-44280	Hexagonal socket set screw 5/8" NC x 1 1/4 lg	4
86	3169-02	Hexagonal plug 1/8" NPT	1
87	9620	Male adaptor "taper-lock"	2
88	110-13321	Sprocket for auger 100A24 x 1T 5.125 + female adaptor "taper-lock"	2
89	140-09411	Key (sprocket for auger)	2
90	300-44340	Bolt 5/8" NC x 2" lg + nylon locknut	16
91	OR-224	Seal 1/8" x 1 3/4" i.d. x 2" o.d.	1
92	FS211	Ductile flange ductile (4 holes)	4
93	HC211-32	Bearing 2" with eccentric collar	4
94	300-40325	Bolt 1/2" NC x 1 3/4 lg + nut & lock washer	16
95	110-12591	Auger hub	2
96	110-38141	Full flight spiked auger with welded carbon steel teeth (64 on each auger)	2
97	130-13861	Tooth (welded on the auger) (64 on each auger)	128
98	130-26052	Right lateral blade	1
99	300-38280	Bolt 7/16" NC x 1 1/4" lg + nylon locknut	4

INDUSTRIAL SNOWBLOWER P-1022TRC-200

REF.	PART #	DESCRIPTION	QTY
100	130-48471	Deflector	1
101	160-08421	Aluminium-bronze bushing 1 3/4" i.d. x 2 1/4" o.d. x 2" lg	1
102	130-48522	Impeller blade	6
103	300-44310	Bolt 5/8" NC x 1 1/2" lg +lock washer	1
104	110-29311	Impeller	1
105	130-08441	Stop block for drum lock (welded on drum)	1
106	160-03952	Body - drum lock (welded on frame)	1
107	150-01542	Latch pin - drum lock	1
108	300-38330	Bolt 7/16" NC x 1 3/4" lg (full length thread) + lock nut.....	1
109	130-08471	Washer	1
110	150-02561	Pin	1
111	HCFS211-32	Bearing 2" + ductile flange + 1 grease fitting	4
112	150-05961	Pin category 2 (top link)	1
113	8375	Hook for adjustable clamp fastener	1
114	300-34280	Bolt 5/16" NC x 1 1/4" lg + nylon locknut	2
115	130-14282	Guard	1
116	140-15821	Spacer for gear box	3

INDUSTRIAL CHUTE PCG-IND

170-03473

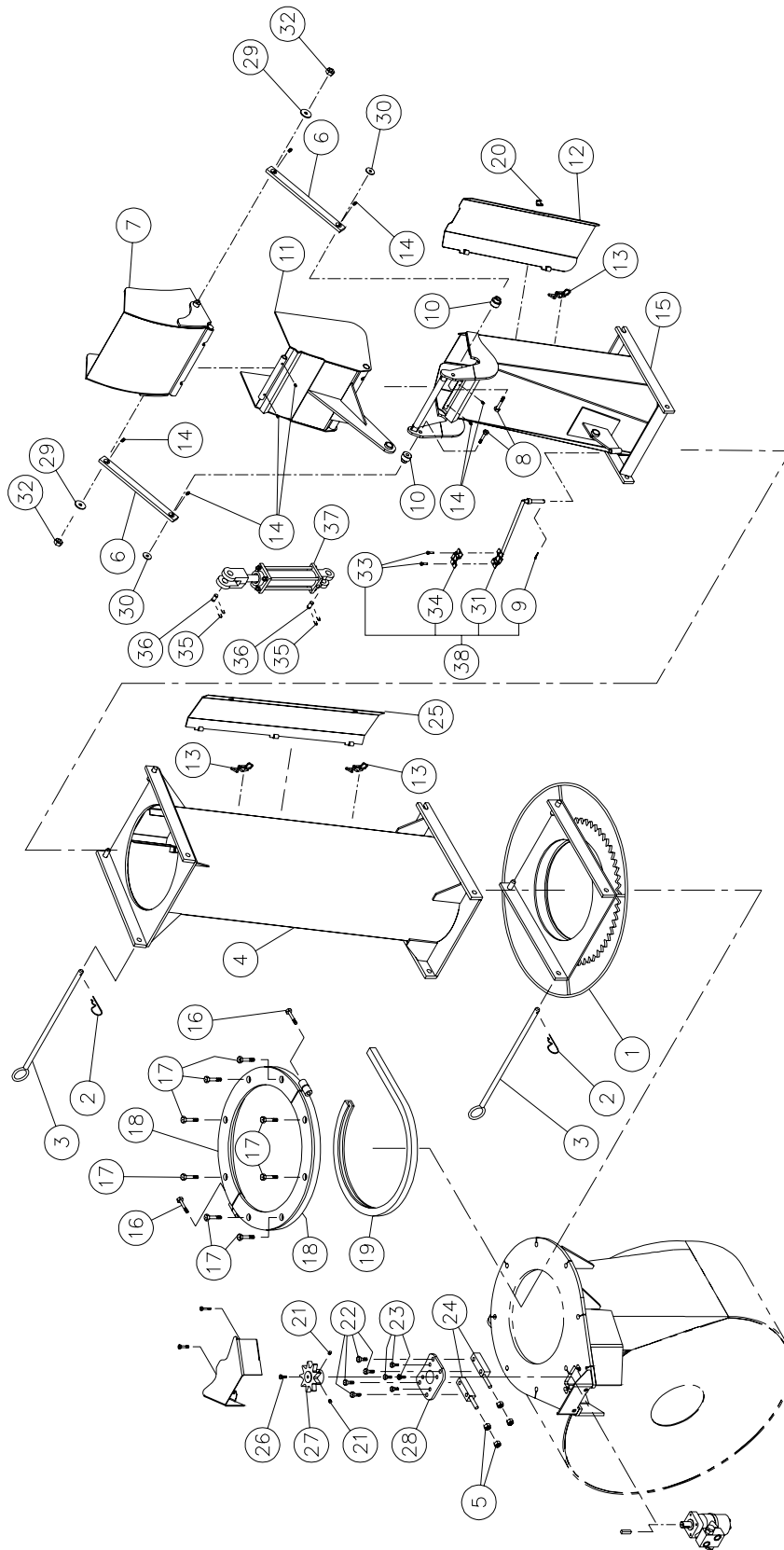

INDUSTRIAL CHUTE PCG-IND

REF.	PART #	DESCRIPTION	QTY
1	110-00681	Chute adaptor with quick attach	1
2	Std.	Hitch pin clip 5/32"	2
3	9414	Pin for quick attach (adaptor & extension)	2
4	PR-IND	Extension 48"	opt.
5	336-38000	Nut 7/16" NC	4
6	140-13931	Connecting rod	2
7	110-38361	Upper deflector	1
8	300-40370	Bolt 1/2" NC x 2 1/2" lg + nylon locknut (thin)	2
9	Std.	Cotter pin 1/8" x 1" lg	1
10	150-05311	Spacer for connecting rod	2
11	110-38371	Lower deflector	1
12	110-22933	Lower deflector	1
13	8376	Adjustable clamp fastener (welded)	1
14	Std.	Grease fitting 1/4" - 28 straight	8
15	110-38441	Chute base	1
16	300-38400	Bolt 7/16" NC x 3" lg + nylon locknut	2
17	300-40400	Bolt 1/2" NC x 3" lg + nylon locknut & 16 flat washers	8
18	110-12351	Retaining bracket	2
19	190-03381	U-shaped UHMW +/- 16" i.d.	1
20	8377	Hook for clamp fastener (welded)	1
21	323-36160	Hexagonal socket set screw 3/8" NC x 3/8" lg	2
22	300-38370	Bolt 7/16" NC x 2 1/2" lg + nylon locknut & flat washer 3/8"	4
23	300-36250	Bolt 3/8" NC x 1" lg + lock washer	4
24	110-38321	Spacer	2
25	110-22952	Access panel for extension 48" # PR-92104P	opt.
26	300-32220	Bolt 1/4" NC x 3/4" lg + lock washer	1
27	110-36731	Sprocket 9 teeth T1	1
28	130-08152	"Orbit" motor support	1
29	378-36500	Upper flat washer for connecting rod	2
30	378-37500	Lower flat washer for connecting rod	2
31	110-01112	Hoses support rod	1
32	346-36000	Nylon locknut 3/8" NC	2
33	300-32250	Bolt 1/4" NC x 1" lg + nylon locknut	2
34	140-13071	Hoses support plate	1
35	Std.	Hairpin cotter 7/8"	4
36	6004	Clevis pin 1" x 3 1/8"	2
37	25TR08	Cylinder 2 1/2" x 8" stroke	1
38	TSB-74104	Hoses support for deflector cylinder	1

HYDRAULIC TELESCOPIC CHUTE PCT-IND

170-02397

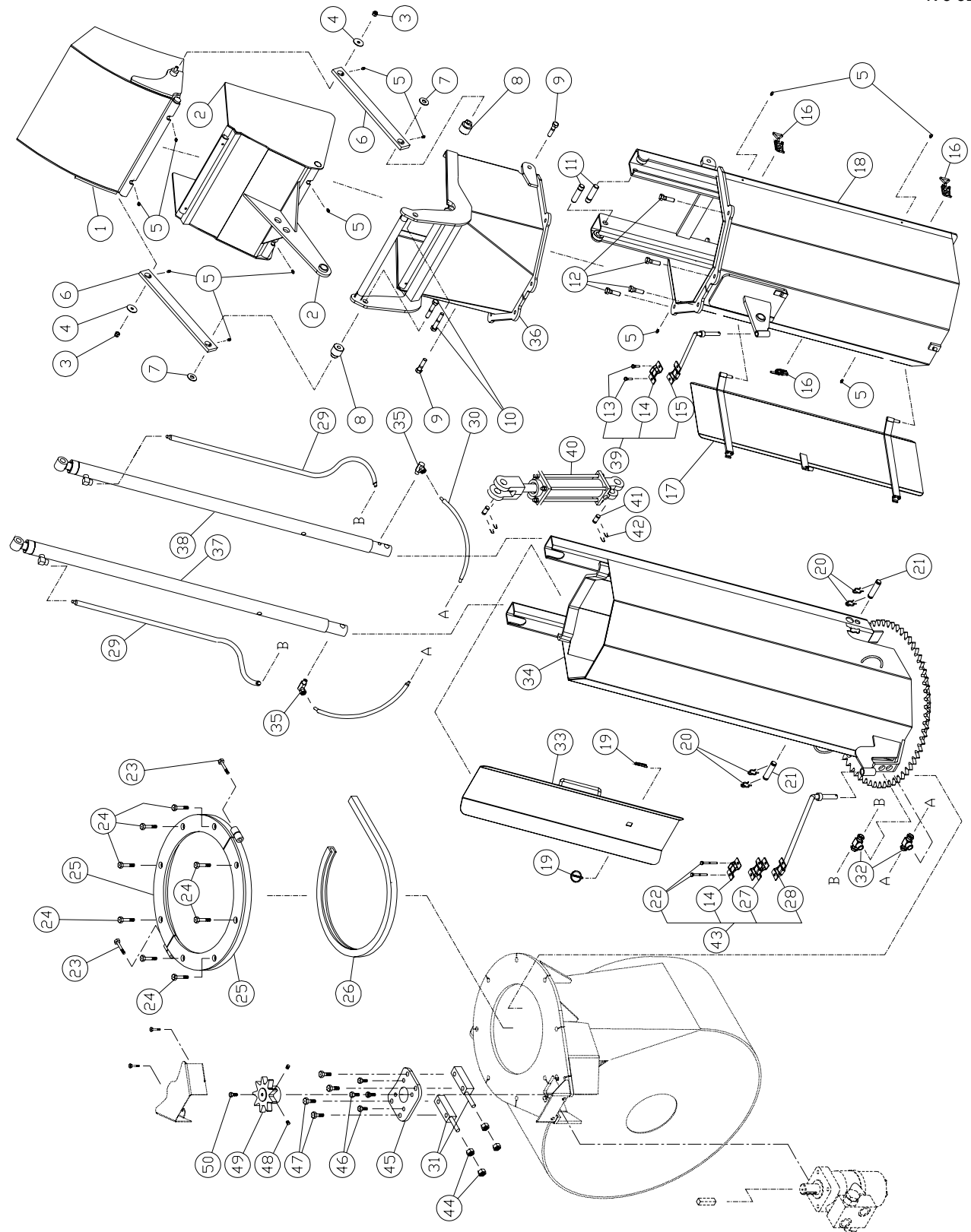

10

HYDRAULIC TELESCOPIC CHUTE PCT-IND

REF.	PART #	DESCRIPTION	QTY
1	110-13463	Upper chute deflector	1
2	110-13492	Lower chute deflector	1
3	346-36000	Nylon locknut 3/8"	2
4	378-36500	Washer 3/8" i.d. x 1 1/2" o.d.	2
5	Std.	Grease fitting 1/4"-28 straight	12
6	140-13931	Connecting rod	2
7	378-37500	Washer 1/2" i.d. x 1 3/8" o.d.	2
8	150-05311	Spacer for connecting rod	2
9	300-40340	Bolt 1/2" NC x 2" lg + nylon locknut	2
10	300-40380	Bolt 1/2" NC x 2 3/4" lg + nylon locknut	2
11	150-08091	Clevis pin 3/4" x 3" lg	2
12	300-40325	Bolt 1/2" NC x 1 3/4" lg + 2 washers + nylon locknut	4
13	300-32250	Bolt 1/4" NC x 1" lg + nylon locknut	2
14	140-13071	Hoses mounting plate	2
15	110-01122	Mounting support plate for upper extension	1
16	8376	Adjustable clamp fastener (welded)	3
17	110-29391	Access panel for upper extension	1
18	110-26641	Upper extension	1
19	Std.	Lynch pin 3/16" x 1 1/4"	2
20	Std.	Hairpin cotter 7/8"	6
21	150-08261	Clevis pin 3/4" x 3 1/16" lg	2
22	300-32370	Bolt 1/4" NC x 2 1/2" lg + nylon locknut	2
23	300-38400	Bolt 7/16" NC x 3" lg + nylon locknut	2
24	300-40400	Bolt 1/2" NC x 3" lg + nylon locknut & 2 washers	8
25	110-12351	Retaining bracket	2
26	190-03381	U-shaped UHMW + - 16" i.d.	1
27	110-20611	Hoses mounting plate	1
28	110-04982	Mounting support plate for lower extension	2
29	190-08231	Hose 1/4" SAE 100R2AT - 500 PSI x 63 1/2" lg	2
30	190-08241	Hose 1/4" SAE 100R2AT - 500 PSI x 20 1/2" lg	2
31	110-38321	Spacer	2
32	9456-06-06	«T» female 3/8" NPT swivel , female 3/8" NPT	2
33	110-26671	Access door for lower extension	1
34	110-13732	Lower extension	1
35	9406-04-04	Elbow 90 degrees 1/4" NPT swivel	2
36	110-34182	Hexagonal extension	1
37	15 PC 32G	Cylinder 1 1/2" x 32" stroke	1
38	15 PC 32D	Cylinder 1 1/2" x 32" stroke	1
39	TSB-74104	Hoses support for deflector cylinder	1
40	25TR08	Cylinder 2 1/2" x 8" stroke	1
41	6004	Clevis pin 1" x 3 1/8" lg (2)	2
42	Std.	Hairpin cotter 7/8" (4)	4
43	TSB-74104-IND	Hoses support on chute base	1
44	336-38000	Nut 7/16" NC	4
45	130-08152	"Orbit" motor support	1
46	300-36250	Bolt 3/8" NC x 1" lg + lock washer	4
47	300-38370	Bolt 7/16" X 2 1/2" lg + nylon locknut & flat washer	4
48	323-36160	Hexagonal socket set screw 3/8" NC x 3/8" lg	2
49	110-36731	Sprocket 9 teeth T1	1
50	300-32220	Bolt 1/4" NC x 3/4" lg + lock washer	1

SEMI-INDUSTRIAL CHUTE PSIG-92104

170-03453

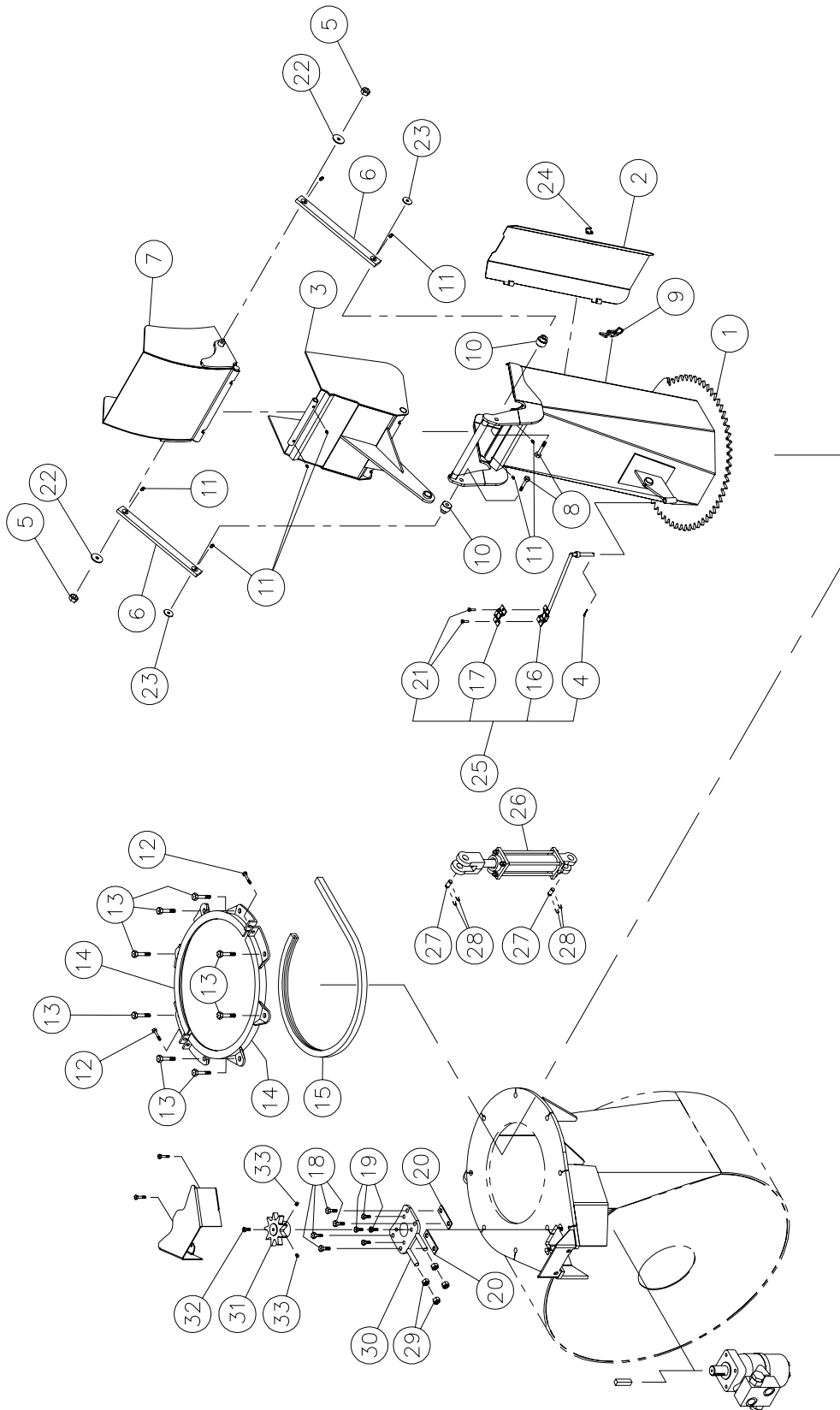

10

SEMI-INDUSTRIAL CHUTE PSIG-92104

REF.	PART #	DESCRIPTION	QTY
1	110-22553	Chute base	1
2	110-22933	Access panel.....	1
3	110-22231	Lower chute deflector	1
4	Std.	Cotter pin 1/8" X 1"	1
5	346-36000	Nylon locknut 3/8" NC	2
6	140-13931	Connecting rod	2
7	110-22241	Upper chute deflector	1
8	300-40400	Bolt 1/2" NC x 3" lg + nylon locknut	2
9	8376	Clamp fastener (welded)	1
10	150-05311	Spacer for connecting rod	2
11	Std.	Grease fitting 1/4" - 28 droit	8
12	300-34340	Bolt 5/16" NC x 2" lg + nylon locknut	2
13	300-40310	Bolt 1/2" NC x 1 1/2" lg + nylon locknut & flat washer	8
14	110-00832	Retaining bracket	2
15	9359	U-shaped UHMW +/- 16 1/2" d.i.	1
16	110-01112	Hoses support rod	1
17	140-13071	Hoses support plate	1
18	300-38325	Bolt 7/16" NC x 1 3/4" lg + lock washer & flat washer 3/8"	4
19	300-36250	Bolt 3/8" NC x 1" lg + lockwasher	4
20	140-09571	Spacer 1/8" x 1" x 3 1/4" lg	2
21	300-32250	Bolt 1/4" NC x 1" lg. + nylon locknut	2
22	378-36500	Upper flat washer for connecting rod	2
23	378-37500	Lower flat washer for connecting rod	2
24	8377	Hook for adjustable clamp fastener (welded)	1
25	TSB-74104	Hoses support for deflector cylinder	1
26	25TR08	Cylinder.....	opt.
27	6004	Clevis pin 1" x 3 1/8" (2).....	opt.
28	Std.	Hairpin cotter 7/8" (4)	opt.
29	336-38000	Nut 7/16" NC.....	4
30	110-20811	"Orbit" motor support	1
31	110-04182	Sprocket 9 teeth	1
32	300-32220	Bolt 1/4" NC x 3/4" lg + lock washer	1
33	323-36160	Hexagonal socket set screw 3/8" NC x 3/8" lg	2

HYDRAULIC TELESCOPIC CHUTE PCT-92104

170-04071

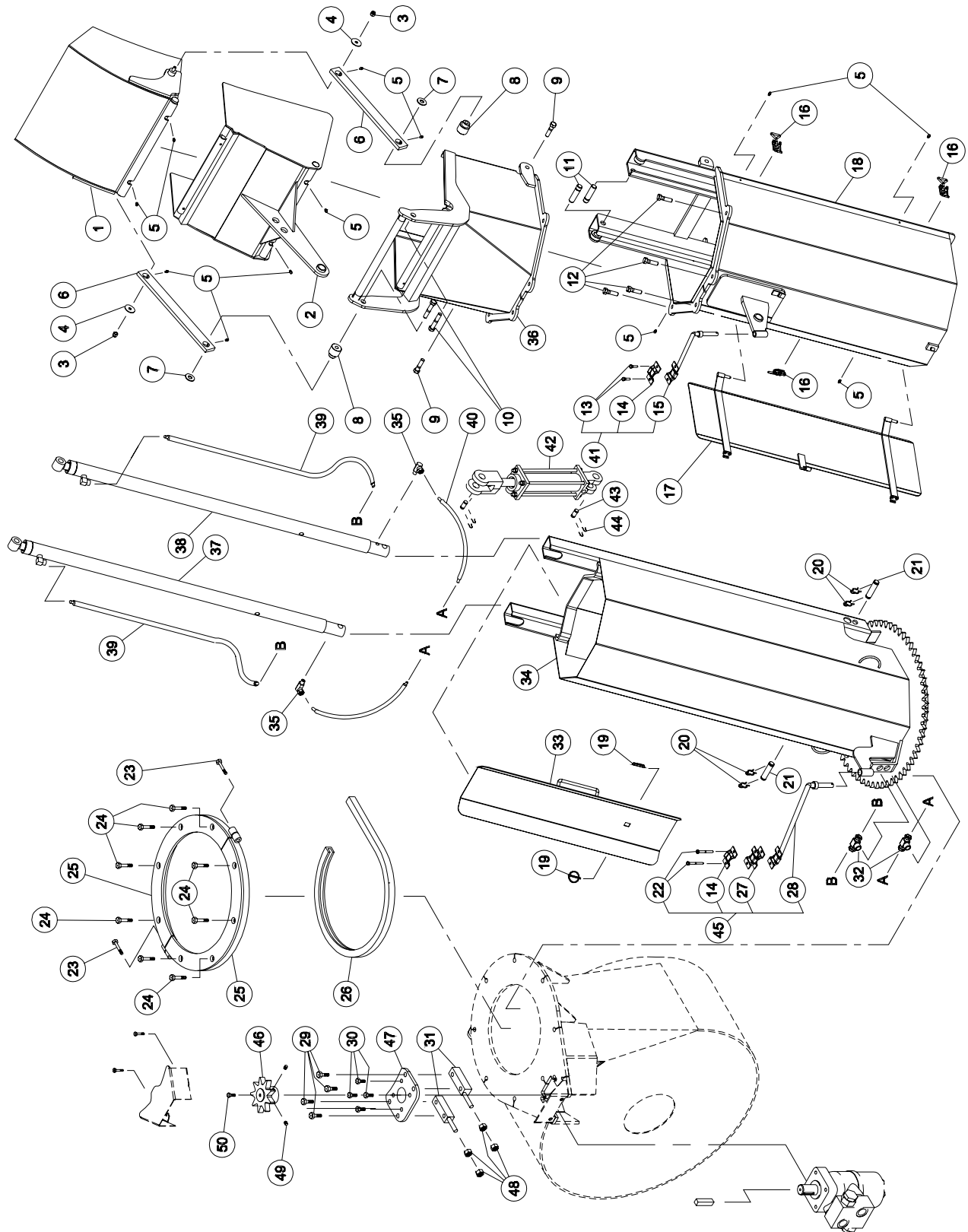

10

HYDRAULIC TELESCOPIC CHUTE PCT-92104

REF.	PART #	DESCRIPTION	QTY
1	110-29111	Upper chute deflector	1
2	110-29121	Lower chute deflector	1
3	346-36000	Nylon locknut 3/8"	2
4	378-36500	Washer 3/8" i.d. x 1 1/2" o.d.	2
5	Std.	Grease fitting 1/4"-28 straight	12
6	140-13931	Connecting rod	2
7	378-37500	Washer 1/2" i.d. x 1 3/8" o.d.	2
8	150-05311	Spacer for connecting rod	2
9	300-40340	Bolt 1/2" NC x 2" lg + nylon locknut	2
10	300-40380	Bolt 1/2" NC x 2 3/4" lg + nylon locknut	2
11	150-08091	Clevis pin 3/4" x 3" lg	2
12	300-40310	Bolt 1/2" NC x 1 1/2" lg + 2 washers + nylon locknut	4
13	300-32250	Bolt 1/4" NC x 1" lg + nylon locknut	2
14	140-13071	Hoses mounting plate	2
15	110-01122	Mounting support plate for upper extension	1
16	8376	Adjustable clamp fastener (welded)	3
17	110-29391	Access panel for upper extension	1
18	110-26641	Upper extension	1
19	Std.	Lynch pin 3/16" x 1 1/4"	2
20	Std.	Hairpin cotter 7/8"	6
21	150-08261	Clevis pin 3/4" x 3 1/16" lg	2
22	300-32370	Bolt 1/4" NC x 2 1/2" lg + nylon locknut	2
23	300-38400	Bolt 7/16" NC x 3" lg + nylon locknut	2
24	300-40400	Bolt 1/2" NC x 3" lg + nylon locknut & 2 washers	8
25	110-12351	Retaining bracket	2
26	190-03381	U-shaped UHMW + - 16" i.d.	1
27	110-20611	Hoses mounting plate	1
28	110-04982	Mounting support plate for lower extension	1
29	300-38370	Bolt 7/16" NC x 2 1/2" lg + nylon locknut & flat washer	4
30	300-36250	Bolt 3/8" NC x 1" lg + lock washer	4
31	160-38321	Spacer 1/2" i.d. x 1" o.d. x 59/64" lg	2
32	9456-06-06	«T» female 3/8" NPT swivel , female 3/8" NPT	2
33	110-26671	Access door for lower extension	1
34	110-26651	Lower extension	1
35	9406-04-04	Elbow 90 degrees 1/4" NPT swivel	2
36	110-29102	Hexagonal extension	1
37	15 PC 32G	Cylinder 1 1/2" x 32" stroke	1
38	15 PC 32D	Cylinder 1 1/2" x 32" stroke	1
39	190-08231	Hose 1/4" SAE 100R2AT - 500 PSI x 63 1/2" lg	2
40	190-08241	Hose 1/4" SAE 100R2AT - 500 PSI x 20 1/2" lg	2
41	TSB-74104	Hoses support for deflector cylinder	1
42	25TR08	Cylinder 2 1/2" x 8" stroke	1
43	6004	Clevis pin 1" x 3 1/8" lg	2
44	Std.	Hairpin cotter 7/8"	4
45	TSB-74104-IND	Hoses support on chute base	1
46	110-36731	Sprocket 9 teeth T1	1
47	130-08152	"Orbit" motor support	1
48	336-38000	Nut 7/16" NC	4
49	323-36160	Hexagonal socket set screw 3/8" NC x 3/8" lg	1
50	300-32220	Bolt 1/4" NC x 3/4" lg + lock nut	1

LATERAL BLADES

170-02125

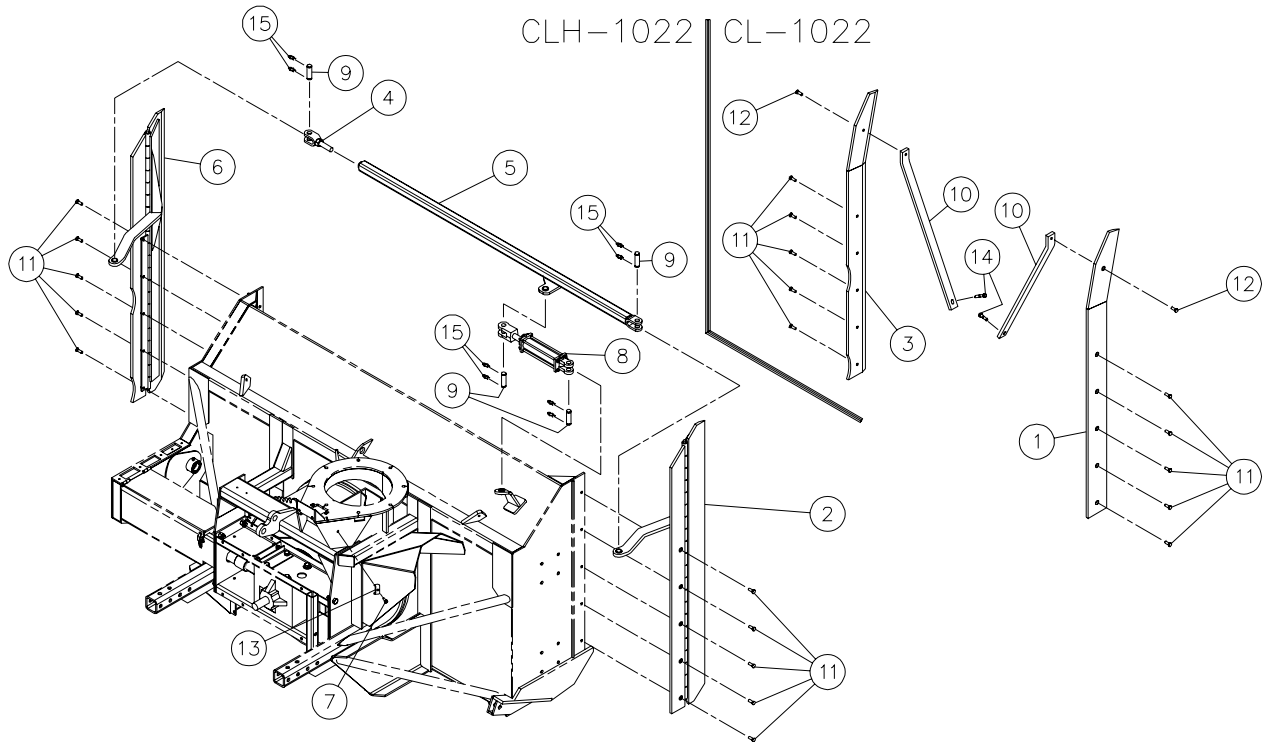

RÉEF.	PART #	DESCRIPTION	QTY	
			CLH-1022	CL-1022
1	110-19192	Sharpened lateral blade - carbon steel (right side)	-	1
2	110-19282	Hydraulic sharpened lateral blade - carbon steel (right side)	1	-
3	110-13223	Sharpened lateral blade - carbon steel (left side)	-	1
4	110-14121	Adjustable yoke + nut 1"-12 NF	1	-
5	110-14132	Connecting tube	1	-
6	110-14453	Sharpened lateral blade - carbon steel (left side)	1	-
7	300-34310	Bolt 5/16" NC x 1 1/2" lg	1	-
8	25TR08	Cylinder 2 1/2" x 8" stroke	1	-
9	6005-1	Pin for cylinder 1" x 3 1/8"	4	-
10	140-12442	Side strengthener	-	2
11	319-40325	Plow bolt 1/2" NC x 1 3/4" lg + nut & lock washer	10	10
12	319-40340	Plow bolt 1/2" NC x 2" lg + nut & lock washer	-	2
13	140-00481	Hoses support	1	-
14	300-40370	Bolt 1/2" NC x 2 1/2" lg + nylon locknut & flat washer	-	2
15	Std.	Hair pin 7/8"	8	-

10

REDUCTION GEAR BOX # 9621 - 200 HP

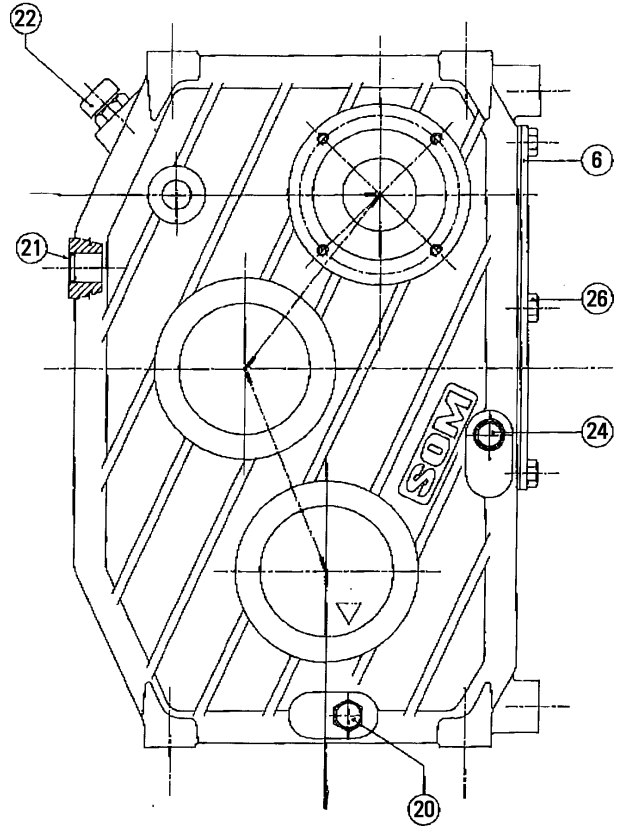
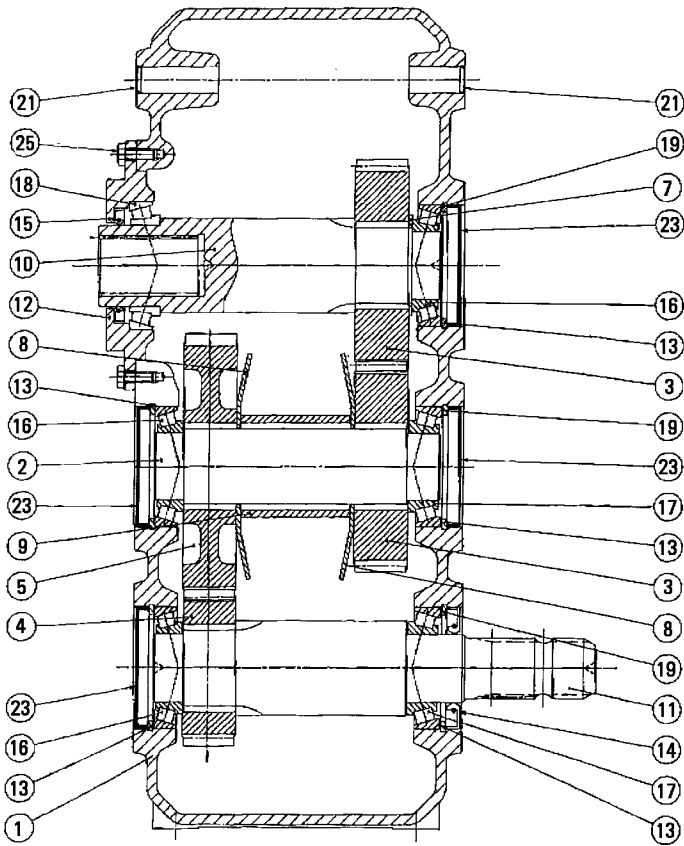

REF.	PART #	DESCRIPTION	QTY
1	9622	Housing	1
2	9623	Shaft	1
3	9624	Ring gear	2
4	9625	Pinion	1
5	9626	Ring gear	1
6	9627	Cover	1
7	9628	Spacer	1
8	9629	Spacer	2
9	9630	Shim	1
10	9631	Output shaft	1
11	9632	Input shaft	1
12	9633	Cover	1
13	9634	Internal snap ring D.90	5
14	9635	Oil seal (50x90x10)	1
15	9636	Oil seal (60x85x8)	1
16	30210-A	Taper roller bearing	3
17	32210-A	Taper roller bearing	2
18	32012X	Taper roller bearing	1
19	9637	Shim kit	3
20	9638	Plug 3/8G	1
21	9639	Plastic plug 20x4	3
22	9640	Plug 1/2G	1
23	9641	Plastic plug 90x10	4
24	9642	Oil level sight glass 3/8G	1
25	9643	Bolt M8x22	8
26	9644	Bolt M10x16	6

P.T.O. SHAFT # 9599 & # 9604

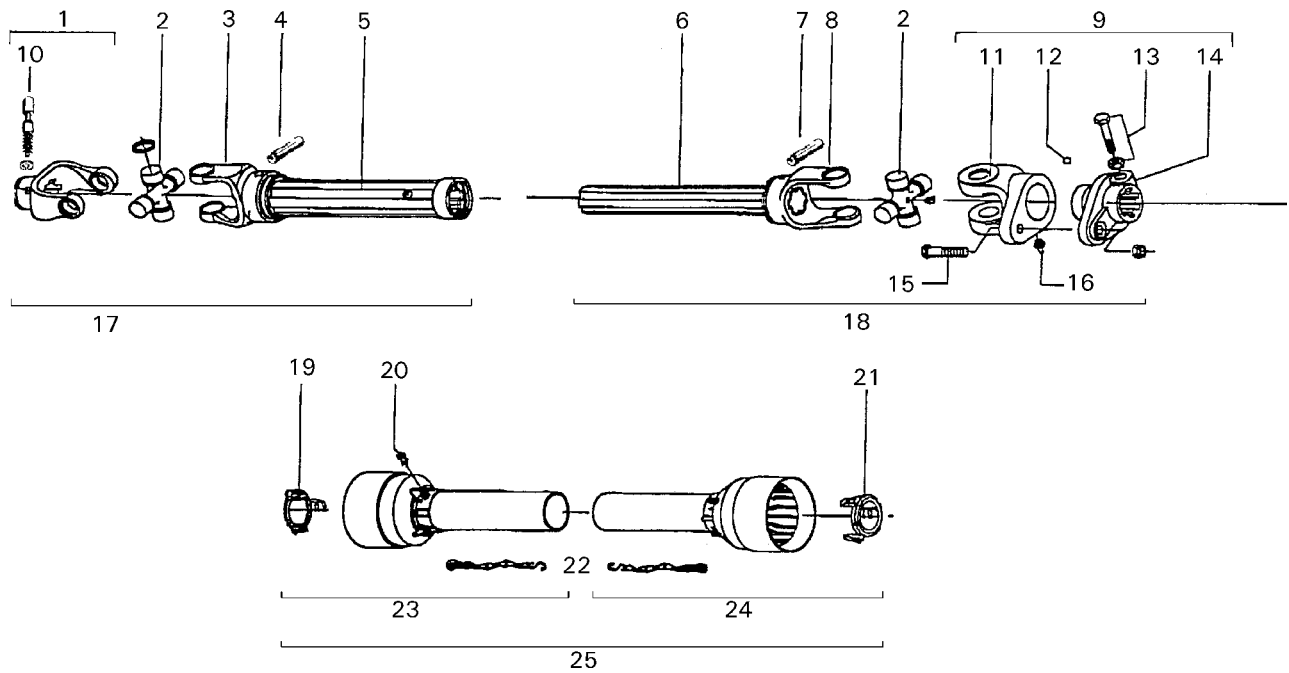

REF.	PART #	DESCRIPTION	QTY
1	9482	Yoke with hole 1 3/8" - 21 splines with lock yoke (1000 RPM)	1
1	9483	Yoke with hole 1 3/4" - 20 splines with lock yoke (1000 RPM)	-
2	9477	U-joint	2
3	9600	Yoke for outer tube	1
4	9210	Stopper for tube	1
5	9601	Outer tube	1
6	9602	Inner tube	1
7	9210	Stopper for tube	1
8	9603	Yoke for inner tube	1
9	9476	Safety shear yoke	1
10	8068-E	Yoke stopper	2
11	9487	Yoke and shearplate M12 x 65	1
12	9205	Ball 5/16" dia.	24
13	9461	Bolt + nut M12x1.25x75	2
14	9486	Adaptor	1
15	9207	Bolt + nut M12x65	1
16	8071	Grease fitting	1
17	9607-1	P.T.O. section, outer part, without protector, 1 3/8" - 21 splines	1
17	9607-2	P.T.O. section, outer part, without protector, 1 3/4" - 20 splines	-
18	9608	P.T.O. section, inner part, without protector	1
19	9460	Bearing ring	1
20	8109	Stopper	6
21	9459	Bearing ring	1
22	8308	Safety chain	2
23	9220	Outer shield	1
24	9221	Inner shield	1
25	9222	Complete shield	1

10

GEAR BOX # 9597 (T301A)

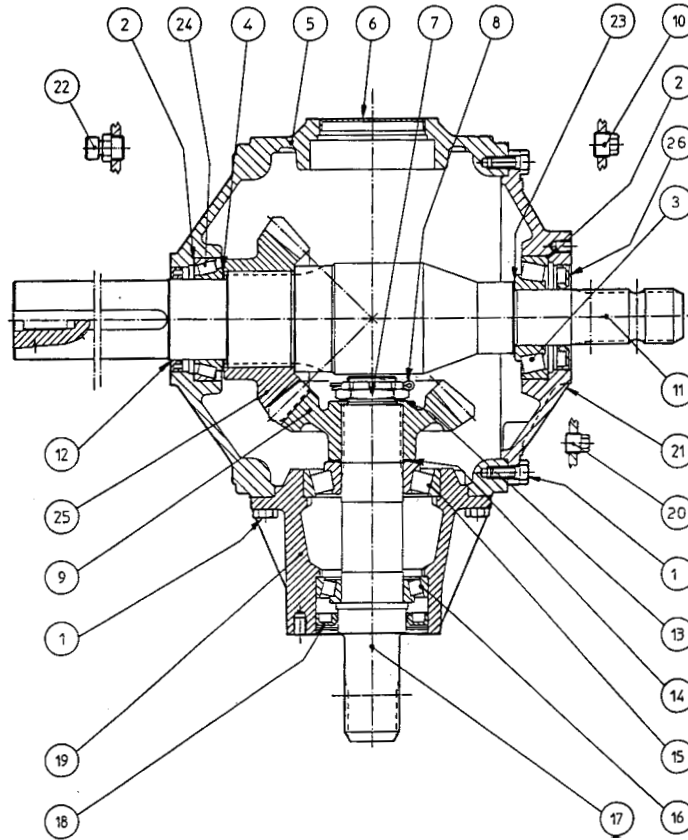

REF.	PART #	DESCRIPTION	QTY
1	9576	Bolt M10 x 25 8,8	18
2	9577	Shim	2
3	30309-A	Bearing 30309	1
4	9578	Shim	1
5	9579	Casing	1
6	9580	Cap	1
7	9581	Nut M40 x 1.5	1
8	9582	Cotter pin B4 x 60	1
9	9583	Gear Z20 M7,8	1
10	9584	Plug 1/2" gas	1
11	9585	Shaft	1
12	9586	Oil seal 65x85x10	1
13	9587	Shim 40.3 x 1.0	1
14	9588	Shim 70.3	1
15	30310-A	Bearing 30310	1
16	30210-A	Bearing 30210	1
17	9589	Shaft 1 3/4" Z20	1
18	9590	Oil seal 55x90x10	1
19	9591	Extension	1
20	8064	Plug 3/8" gas	1
21	9592	Cover	1
22	9593	Oil filler plug 1/2G	1
23	9594	Shim 65.3	1
24	32013X	Bearing 32013 x	1
25	9595	Gear Z20 M7.8	1
26	9596	Oil seal 45x85x10	1

CYLINDER 25TR08

15050

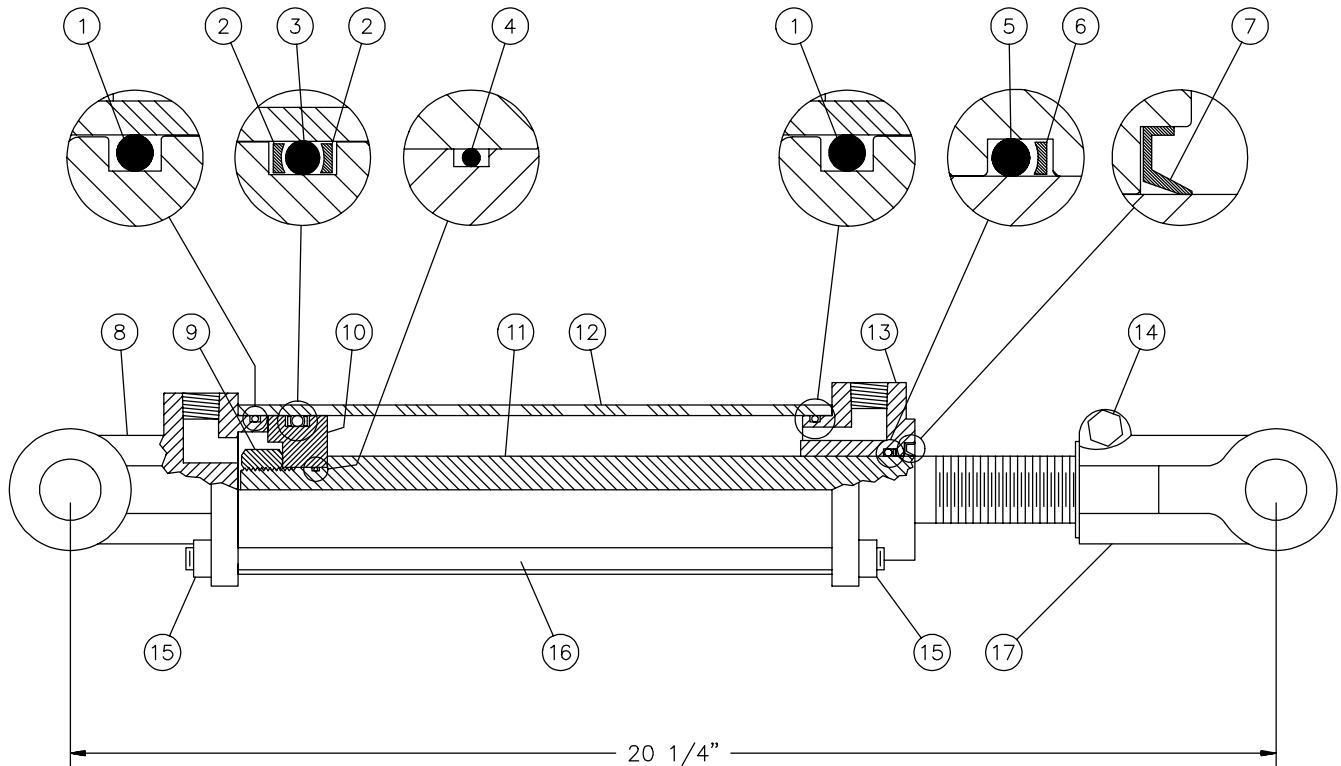

REF.	PART #	DESCRIPTION	QTY
1	See RK25TR	O-ring 1/8" x 2 1/4" x 2 1/2"	2
2	See RK25TR	Back-up 2 1/2" o.d. x 3/16 ø	2
3	See RK25TR	O-ring 3/16" x 2 1/8" x 2 1/2"	1
4	See RK25TR	O-ring 1/16" x 5/8" x 3/4"	1
5	See RK25TR	O-ring 1/8" x 1 1/8" x 1 3/8"	1
6	See RK25TR	Back-up 1 3/8" o.d. x 1/8" ø	1
7	See RK25TR	Wiper 1 1/8" i.d. x 1 5/8" o.d.	1
8	492401	Yoke (for tube 2 1/2")	1
9	338-46000	Nut 3/4" NF	1
10	4924-31	Piston 2 1/2" ø	1
11	492028	Piston rod 1 1/8"	1
12	491668	Cylinder body 2 1/2" ø	1
13	492421	Head (for 2 1/2" tube)	1
14	300-36355	Bolt 3/8" NC x 2 1/4" + nut	1
15	336-36000	Nut 3/8" NC	8
16	Std.	Threaded rod 3/8" NC	4
17	458599	Yoke (for 1 1/8" rod)	1
NI*	8183	Pin 1" ø + cotter pin	2
NI*	RK25TR	Repair kit for cylinder 2 1/2" (includes # 1, 2, 3, 4, 5, 6, & 7)	1

*NI = NOT ILLUSTRATED

CYLINDER 15PC32

170-04361

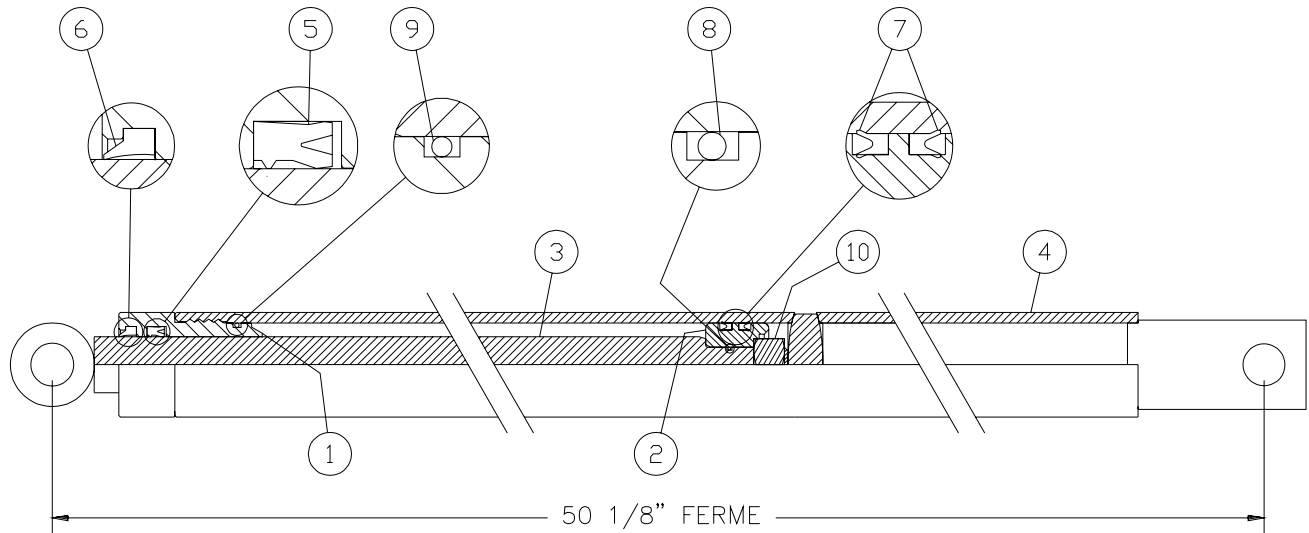

REF.	PART #	DESCRIPTION	QTY	
			15PC32D	15PC32G
1	150-06561	Head 1 1/2" dia.	1	1
2	150-06571	Piston 1 1/2" dia.	1	1
3	110-26561	Piston rod 1" dia.	1	1
4	110-29631	Cylinder body 1 1/2" dia. (15PC32D)	1	-
4	110-29632	Cylinder body 1 1/2" dia. (15PC32G)	-	1
5	DRTU-18-1.00-31	«U» seal 3/16" x 1" x 1 3/8"	1	1
6	ST-100	Wiper 3/16" x 1" x 1 1/8"	1	1
7	DSU12-1.25-18	«U» seal 3/16" x 1 1/4" x 1 1/2"	2	2
8	OR-014	O-ring 1/16" x 1/2" x 5/8"	1	1
9	OR-125	O-ring 3/32" x 1 5/16" x 1 1/2"	1	1
10	336-44000	Nut 5/8" NC	1	1
NI*	9689	Repair kit (includes # 5, 6, 7, 8 & 9)	1	1

*NI = NOT ILLUSTRATED

HYDRAULIC MOTOR # MLH 315

CUSHION VALVE H110

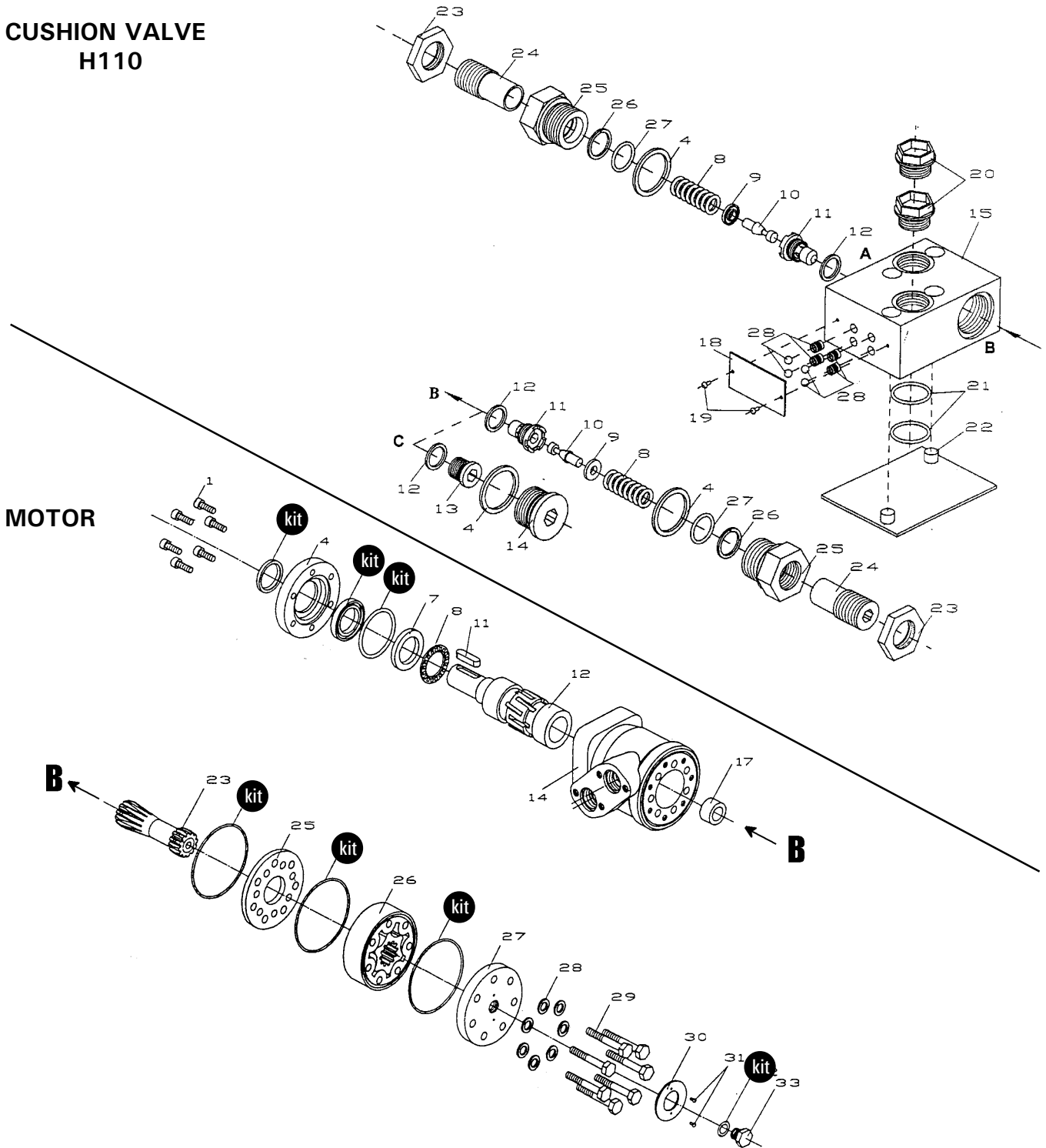







10





REF.	PART #	DESCRIPTION	QTY
kit	8368	Set of seals.....	1
11	8369	Key for "Orbit" motor.....	1

TORQUE CHART

TORQUE SPECIFICATION TABLE

Thread UNC and UNF		Grade 2 				Grade 5   				Grade 8*   			
Bolt size		Torque				Torque				Torque			
Inches	mm	Pound feet min.	max.	Newton meters min.	max.	Pound feet min.	max.	Newton meters min.	max.	Pound feet min.	max.	Newton meters min.	max.
1/4	6.35	5	6	6.8	8.13	9	11	12.2	14.9	12	15	16.3	30.3
5/16	7.94	10	12	13.6	16.3	17	20.5	23.1	27.8	24	29	32.5	39.3
3/8	9.53	20	23	27.1	31.2	35	42	47.5	57.0	45	54	61.0	73.2
7/16	11.11	30	35	40.7	47.4	54	64	73.2	86.8	70	84	94.9	113.9
1/2	12.70	45	52	61.0	70.5	80	96	108.5	130.2	110	132	149.2	179.0
9/16	14.29	65	75	88.1	101.6	110	132	149.2	179.0	160	192	217.0	260.4
5/8	15.88	95	105	128.7	142.3	150	180	203.4	244.1	220	264	298.3	358.0
3/4	19.05	150	185	203.3	250.7	270	324	366.1	439.3	380	456	515.3	618.3
7/8	22.23	160	200	216.8	271.0	400	480	542.4	650.9	600	720	813.6	976.3
1	25.40	250	300	338.8	406.5	580	696	786.5	943.8	900	1080	1220.4	1464.5
1 1/8	25.58	-	-	-	-	800	880	1084.8	1193.3	1280	1440	1735.7	1952.6
1 1/4	31.75	-	-	-	-	1120	1240	1518.7	1681.4	1820	2000	2467.9	2712.0
1 3/8	34.93	-	-	-	-	1460	1680	1979.8	2278.1	2380	2720	3227.3	3688.3
1 1/2	38.10	-	-	-	-	1940	2200	2630.6	2983.2	3160	3560	4285.0	4827.4

* Thick nuts must be used with grade 8 bolts.

Size of screw	Thread	Pitch (mm)	Grade 4T  				Grade 7T 				Grade 8T  			
			Torque				Torque				Torque			
			Pound feet min.	max.	Newton meters min.	max.	Pound feet min.	max.	Newton meters min.	max.	Pound feet min.	max.	Newton meters min.	max.
M6	UNC	1.00	3.6	5.8	4.9	7.9	5.8	9.4	7.9	12.7	7.2	10	9.8	13.6
M8	UNC	1.25	7.2	14	9.8	19	17	22	23	29.8	20	26	27.1	35.2
M10	UNC	1.5	20	25	27.1	33.9	34	40	46.1	54.2	38	46	51.5	62.3
M12	UNC	1.75	28	34	37.9	46.1	51	59	69.1	79.9	57	66	77.2	89.4
M14	UNC	2.0	49	56	66.4	75.9	81	93	109.8	126	96	109	130.1	147.7
M16	UNC	2.0	67	77	90.8	104.3	116	130	157.2	176.2	129	145	174.8	196.5
M18	UNC	2.0	88	100	119.2	136	150	168	203.3	227.6	175	194	237.1	262.9
M20	UNC	2.5	108	130	146.3	176.2	186	205	252	277.8	213	249	288.6	337.4
M8	UNF	1.0	12	17	16.3	23	19	27	25.7	36.6	22	31	29.8	42
M10	UNF	1.25	20	29	27.1	39.3	35	47	47.4	63.7	40	52	54.2	70.5
M12	UNF	1.25	31	41	42	55.6	56	68	75.9	92.1	62	75	84	101.6
M14	UNF	1.5	52	64	70.5	86.7	90	106	122	143.6	107	124	145	168
M16	UNF	1.5	69	83	93.5	112.5	120	138	162.6	187	140	158	189.7	214.1
M18	UNF	1.5	100	117	136	158.5	177	199	239.8	269.6	202	231	273.7	313
M20	UNF	1.5	132	150	178.9	203.3	206	242	279.1	327.9	246	289	333.3	391.6

Use the above torques when special torque is not given.

NOTE: These values apply to fasteners as received from supplier, dry, or when lubricated with normal engine oil. They do not apply if extreme pressure lubricants are used.

WARRANTY

12

PRONOVOST warrants this product to the initial purchaser for the period of one year from the date of purchase against defects in materials and workmanship.

We will replace or repair defective parts free of charge if they are returned to our plant in St-Tite, Quebec, Canada.

Transportation charges are the responsibility of the customer. This warranty is not transferable.

Hydraulic cylinders and motors are covered by the manufacturer of these items.

The PTO shafts are warranted by the manufacturer and cover **only** defects in material and workmanship, and is conditional to recommended use and installation only.

All PRONOVOST spare parts purchased are covered by a three (3) month warranty.

This warranty becomes void and nul if the equipment is modified, breaks down as the result of an accident, is not operated according to manufacturer's recommendations, damaged by negligence or if maintenance has not been carried out as specified.

Our obligation is limited to the replacement or repair of the defective part. PRONOVOST accepts no responsibility for direct or indirect consequential damages of any kind.

Ce manuel est aussi disponible en français.
Veuillez téléphoner.



INNOVATION - EXCELLENCE

LES MACHINERIES PRONOVOST INC.

260, route 159,

Saint-Tite, Quebec, Canada, G0X 3H0

Tel.: (418) 365-7551, Fax: (418) 365-7954

www.pronovost.qc.ca