

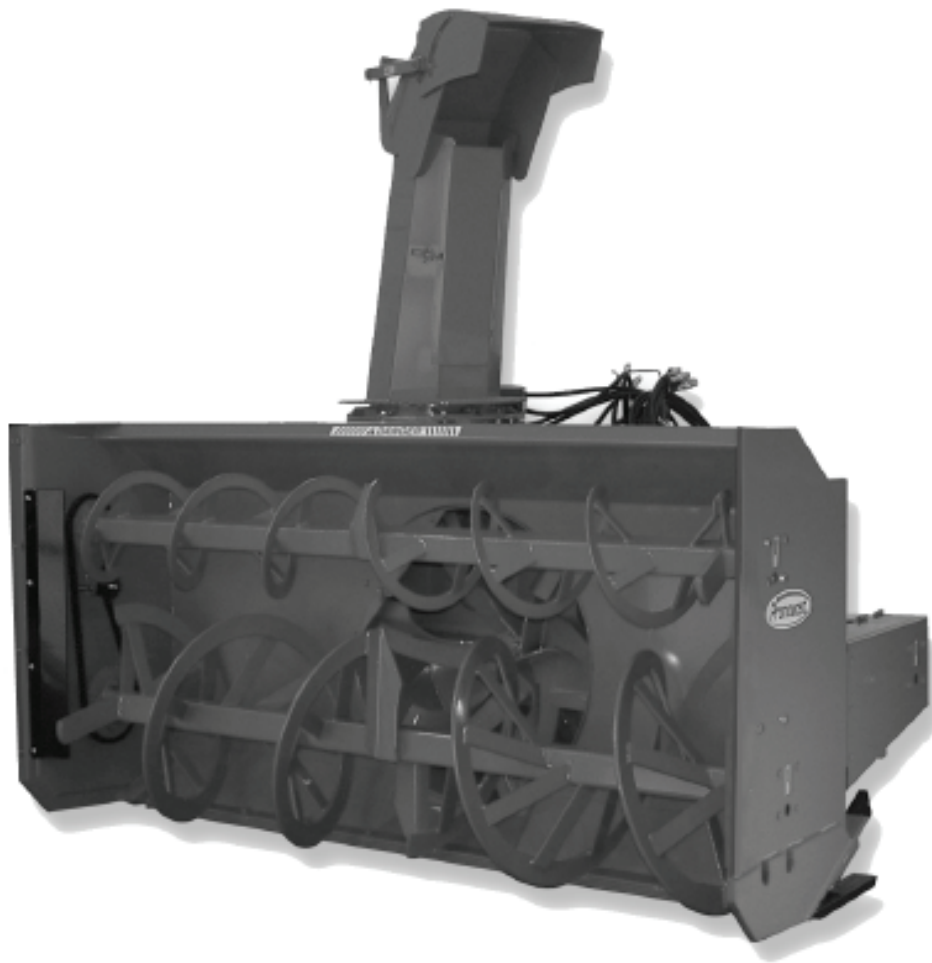

**OPERATOR'S / PARTS
MANUAL**



Snowblowers
Models

P-992 & P-992TRC P-980 & P-980TRC
P-1020 & P-1020TRC P-1040 & P-1040TRC



Copyright © Les Machineries Pronovost Inc., 2010

All rights reserved.
Printed in Canada.

TABLE OF CONTENTS

Section	Item	Page
1	Introduction	5
2	Safety	6
	General Safety	6
	Safety in Operation	6
	Safety with Maintenance	7
	Safety in Transport	7
	Safety in Storage	7
3	Decals	8
	Safety Decals	8
	Maintenance Decals	12
4	Assembly	13
	General assembly	13
	Motor on the rotary drum	14
	Hydraulic Chute Kit: Motor	15
5	Start-up	16
	Basic Start-up Procedures	16
6	Maintenance	17
	General maintenance	17
7	Storage	18
8	Trouble Shooting	19
9	Specifications	21
10	Parts List	22
	Snowblower P-992	22
	Snowblower P-992TRC	25
	Snowblowers P-980 P-1020 P-1040	28
	Snowblowers P-980TRC P-1020TRC P-1040TRC	31
	Semi-industrial Chute PSIG-92104	35
	Industrial Chute PCG-92104	37
	Hydraulic telescopic chute PCT-92104	39
	Hydraulic telescopic chute PCTC-INDR	41
	Options	44
	Option upper auger	47
	P.T.O. Shaft # 9225 & # 9569	48
	P.T.O. Shaft # 9475	49
	Gear Box # 9307	50
	Reduction Gear Box # 9769	51
	Reduction Gear Box # 9721	52
	Cylinder 25TR08	53
	Cylinder 15PC32	54
	Cylinder 15L12	55
	Hydraulic Motor MLH-250 & MLH-315	56
11	Torque Chart	57
12	Warranty	58

INTRODUCTION

CONGRATULATIONS!

Thank you for choosing PRONOVOST. We are confident this equipment will meet your requirements in terms of quality, performance and reliability.

This manual was prepared to assist you in the safe operation of your new Snowblower. It contains important information which will help you achieve excellent returns with your Snowblower for years to come.

Please read this manual completely before operating your Snowblower and keep it for future reference.

Before starting the machine, you or any other person who will be operating the Snowblower must familiarize yourself with the safety recommendations and the operating instructions. Please read carefully and be sure to understand and follow all recommendations and procedures.

In this manual, the right and left sides are identified as shown on Figure 1.

If you require additional information on your Snowblower, please contact your PRONOVOST Dealer.

NOW take a moment to enter the model, serial number and the date of purchase of your Snowblower in the space provided.

When ordering parts from your Dealer, please refer to these numbers for a fast and efficient service. Use PRONOVOST parts for replacement.

The model and serial numbers are on the name plate shown on Fig. 1.

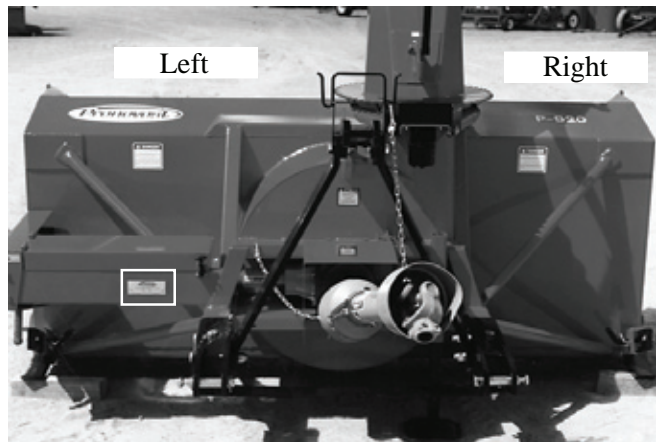

Figure 1

MODEL: _____ ✍

SERIAL NO: _____ ✍

DATE OF PURCHASE: _____ ✍

SAFETY

GENERAL SAFETY

2

WHEN YOU SEE THIS SYMBOL



ATTENTION!

**BE ALERT
YOUR SAFETY IS INVOLVED**

This symbol «**SAFETY ALERT**» is used in this manual and on the safety decals on the Snowblower. It warns you of the possibility of danger. Carefully read, understand and follow all safety recommendations before operating the Snowblower.

- 1) Careful operation is the best assurance against accidents. Carefully read this manual and follow all recommendations before operating your Snowblower. It is the owner's responsibility to make sure that anyone who will operate the Snowblower will read this manual before operating the equipment.
- 2) Familiarize yourself with all controls and always be ready to stop the Snowblower quickly in case of emergency.
- 3) Never let a child operate the Snowblower.
- 4) Do not modify the Snowblower. Any non authorized modification may affect the efficiency and/or safety of the equipment and will automatically void the warranty.
- 5) Never operate the Snowblower with defective parts or if damaged in any way. Have it repaired before operating.
- 6) Make sure all fasteners are in place and properly secured or tightened. Refer to torque chart on page 57.
- 7) Avoid wearing loose fitting clothing when working with the Snowblower. These could get entangled in moving parts of the equipment and cause accidents.

- 8) Prolonged exposure to noise may hamper hearing. Protect yourself by wearing adequate protection devices.
- 9) Hydraulic fluids under pressure can damage your skin. Do not use your hands to locate a leak.
- 10) Before the beginning of the snow season, inspect all areas where the Snowblower will be used and remove any object which may cause an accident and/or damage the equipment.
- 11) Never operate your Snowblower in poor visibility or without proper lighting conditions.

SAFETY IN OPERATION

- 1) Be sure there are no obstructions around the equipment and that no one stands near the equipment when in operation.
- 2) Do not operate an engine in a confined or non ventilated area.
- 3) Do not perform any adjustments, cleaning, maintenance or repairs with the engine running. The engine must be stopped and the P.T.O. disengaged. Preferably remove the key from the ignition.
- 4) Wear adequate clothing when working in cold or windy conditions.
- 5) Adjust skid shoes for proper ground clearance of scraper blade, especially in rough terrain or soft ground conditions.
- 6) Before operating, make sure the P.T.O. is properly installed and secured.
- 7) Before starting-up the Snowblower, make sure the auger and drum areas are free of ice.
- 8) Put P.T.O. control in neutral position before starting engine.
- 9) Keep hands, feet and clothing away from moving parts of the Snowblower. Stay away from the discharge chute.

SAFETY (cont'd)

- 10) Before unplugging the chute, always disengage the P.T.O., stop the engine and relieve all hydraulic pressures.
- 11) Do not operate in excessive inclined conditions. Be careful when turning in slopes.
- 12) Never operate your Snowblower with missing guards or without protective devices in place.
- 13) Do not operate your Snowblower near buildings, windows or other vehicles without prior and proper adjustment of the chute deflector.
- 14) Never aim discharge chute towards people or animals. This may cause serious injuries.
- 15) Always reduce operating speed in slippery conditions.
- 16) Be careful when backing-up, make sure you have good visibility.
- 17) Always be on the lookout for objects which may enter the snowblower.
- 18) If undue vibrations are felt, disengage the P.T.O., stop the motor and look for the cause of the vibration. Vibration is usually the indication of a problem.
- 19) At the end of the operation, disengage the P.T.O., lower the Snowblower, put transmission in neutral, apply parking brake, stop engine and remove the key from the ignition.

SAFETY WITH MAINTENANCE

- 1) Perform the Snowblower maintenance according to recommendations contained in this manual.

- 2) Stop engine and relieve all hydraulic pressures before doing inspection, maintenance or repairs.
- 3) Never perform any work under the Snowblower while it is supported only by the tractor's hydraulic system. It must be completely supported by wooden blocks or other safe means.

SAFETY IN TRANSPORT

- 1) On public roads, use proper safety lights and check local regulations.
- 2) Be alert while driving on the road. Never carry passengers.
- 3) Always disengage P.T.O. while moving from one area of work to another.
- 4) It is recommended to use both brake pedals simultaneously for better control.
- 5) The recommended road speed should be such as to maintain full control over steering and braking.
- 6) Be careful while backing up, make sure you have good visibility.

SAFETY IN STORAGE

- 1) Provide adequate supports to prevent any accidental overturning of the Snowblower.
- 2) Do not let children play in the area where the Snowblower is stored.

2

DECALS

SAFETY DECALS

The safety decals are affixed wherever special safety precautions are indicated. Locate them on the machine and read them carefully. If a decal is damaged, lost or illegible, install a new one. The following photos indicate where each one must be installed.

3

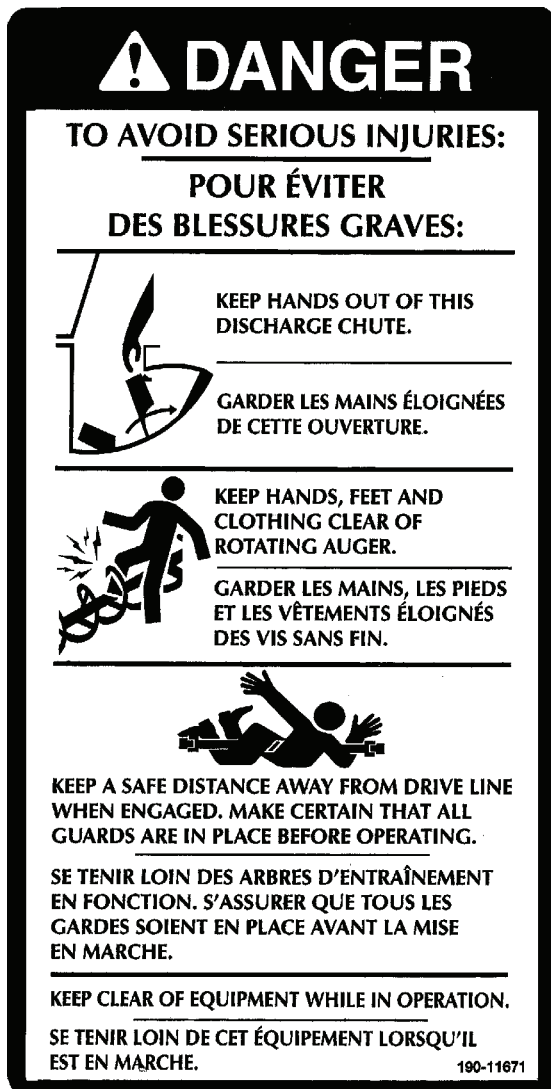

Figure 2
Decal A

Part no.: 190-11671

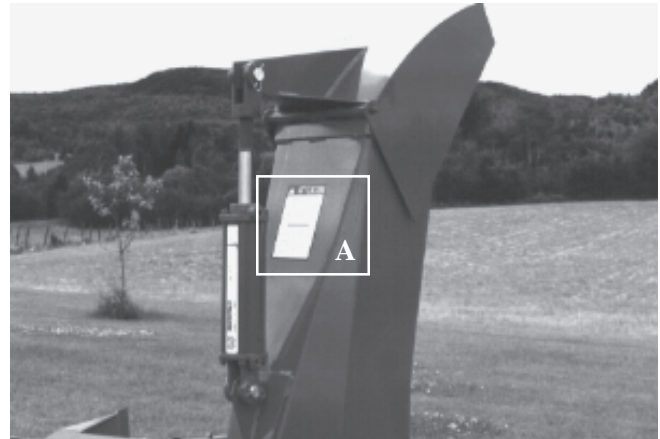

Figure 3

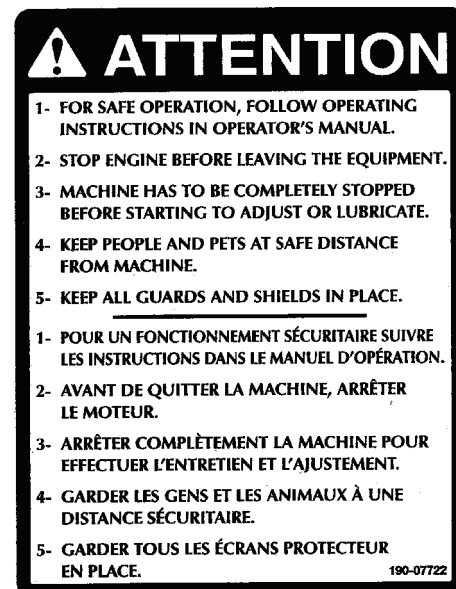

Figure 4
Decal B

Part no.: 190-07722



Figure 5

DECALS (cont'd)



Figure 6
Decal C Part no.: 190-11641

If your snowblower is equipped with a reduction gear box, the decal C will be the one shown below.



Figure 7
Decal C Pièce no.: 190-11651

Decal E in Fig. 9 is located directly on the P.T.O. shaft. It is not visible when the safety shield is in place. It must never be visible when you operate the equipment.



Figure 8
Decal E Part no.: A108

3

DECALS (cont'd)

3



190.000.215

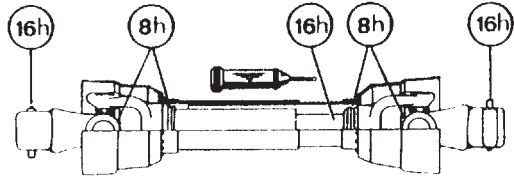

Figure 9
Decal F

Part no.: A 109

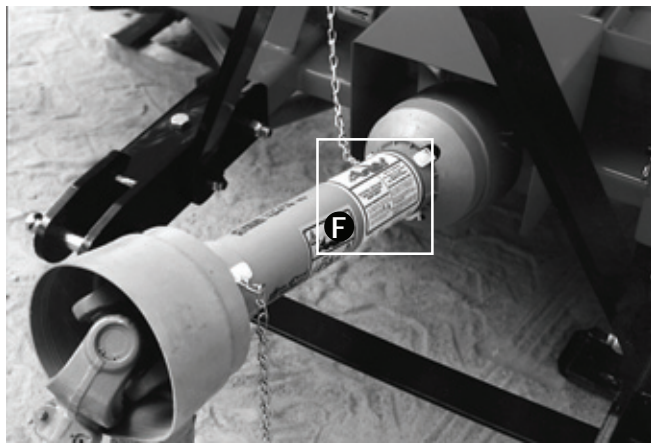

Figure 10



Figure 11
Decal D

Part no.: A103

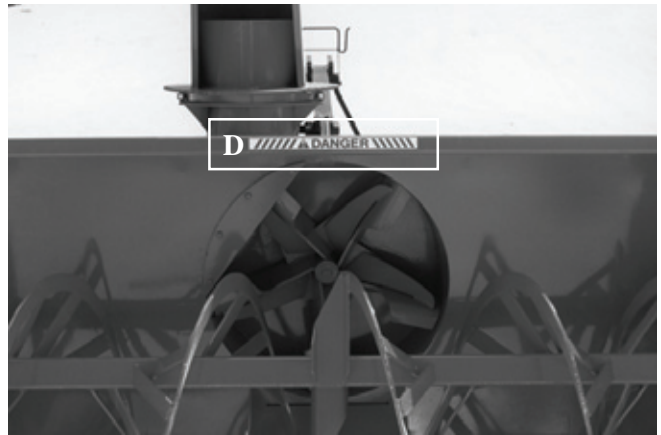

Figure 12



Figure 13
Decal G

Part no.: 190-10991

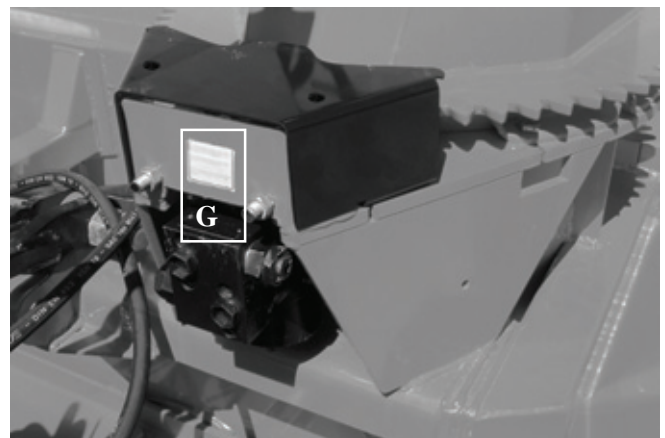

Figure 14

DECALS (cont'd)

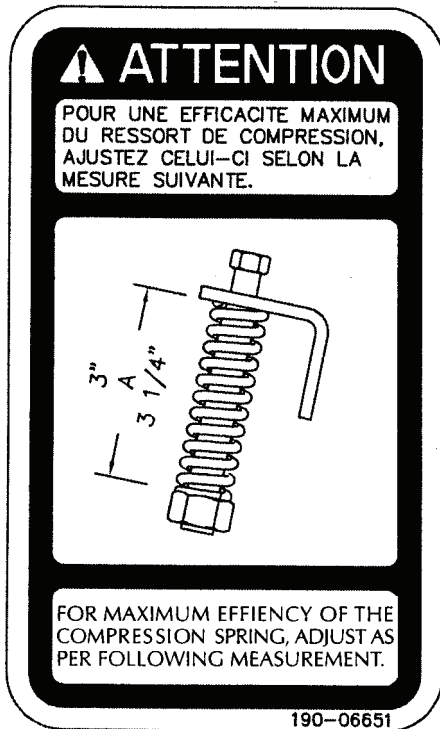

Figure 15
Decal H

Part no.: 190-06651

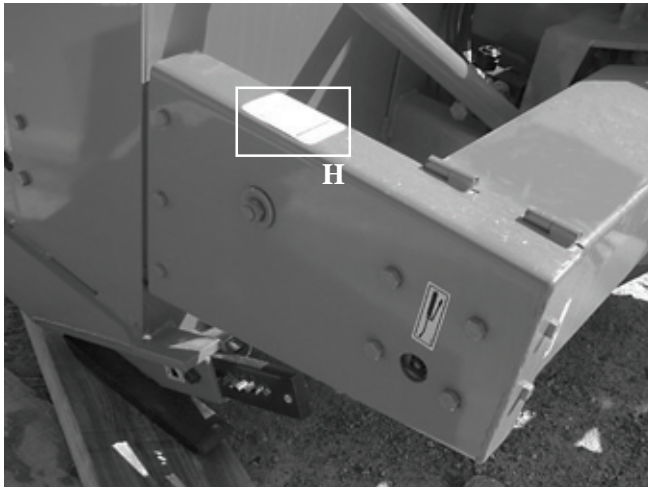

Figure 16

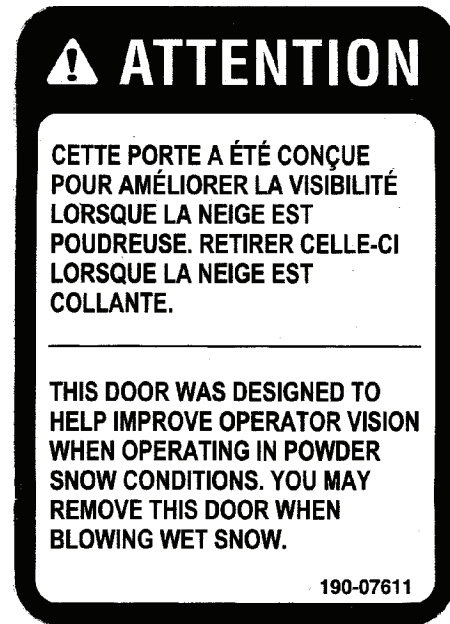

Figure 17
Decal J

Part no.: 190-07611



Figure 18

DECALS (cont'd)

MAINTENANCE DECALS

The maintenance decals indicate the points requiring lubrication. Refer to maintenance section for more details.

3



Figure 19
Decal K

Part no.: 190-11591



Figure 22

Part no.: A 106



Figure 23
Decal L

Part no.: 190-11581



Figure 20

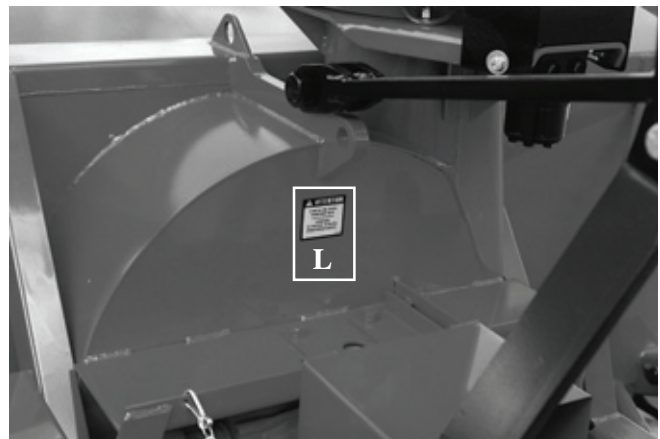

Figure 24

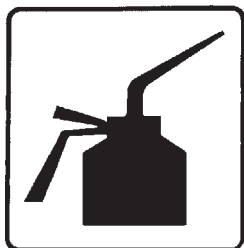

Figure 21

Part no.: A 105

ASSEMBLY



Figure 25

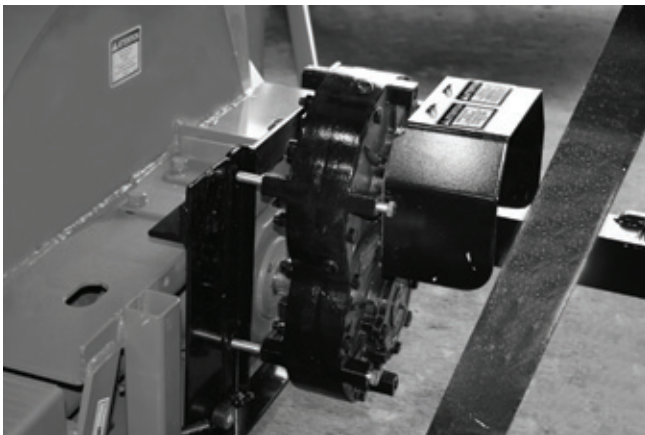

Figure 26

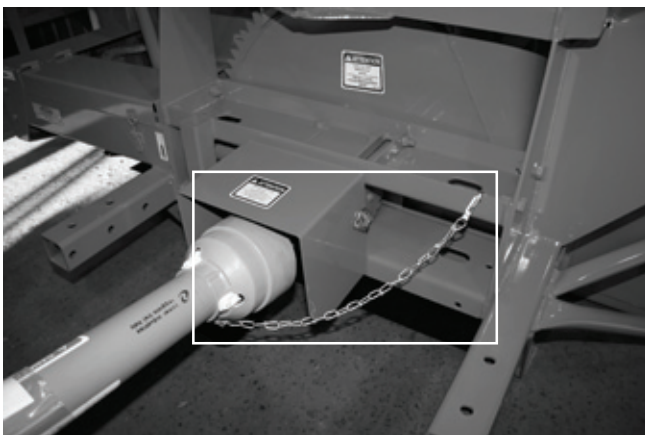

Figure 27

ASSEMBLY

- 1) The Snowblower is shipped partly assembled.
- 2) Install 3-point system according to the model of your Snowblower. (See section 10 for parts numbers). Use the holes most convenient to the type of tractor used (Fig. 25).
- 3) If your snowblower is equipped with the optional 1000 to 540 RPM reducer, install it on the gear box with the plate included (Fig. 26).
- 4) Install P.T.O. shaft with the shear pin end onto the Snowblower gear box. Then attach safety shield support chain as shown (Fig. 27). **WARNING:** The telescoping tubes of the drive shaft must never be allowed to bottom out while maintaining a minimum overlap of 6 inches.
- 5) If equipped with a rotating drum, please refer to page 14 for installation instructions.
- 6) For the installation of the chute rotation mechanism, please refer to page 15.

4

ASSEMBLY (cont'd)

4

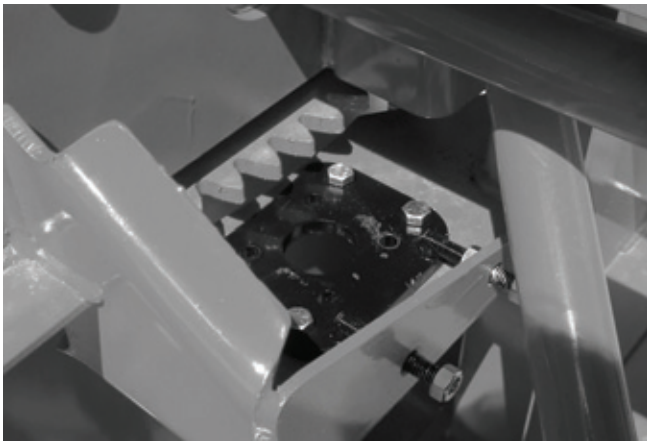

Figure 28

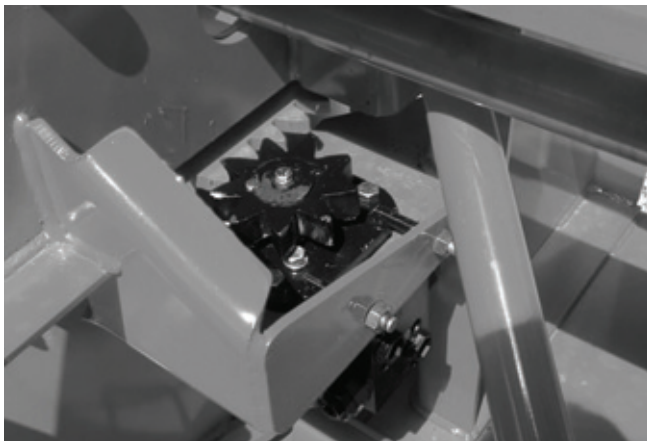

Figure 29

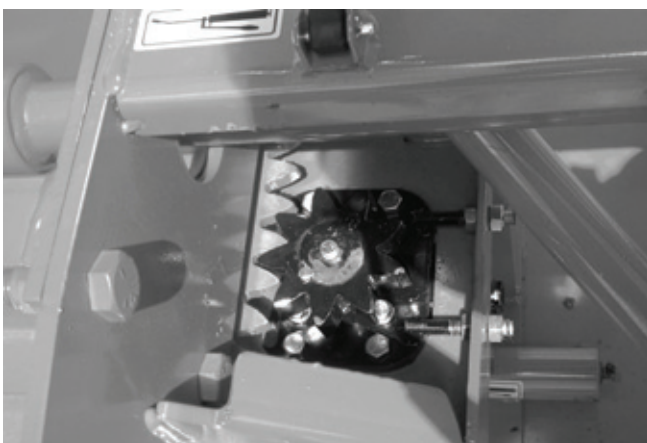

Figure 30

MOTOR ON THE ROTARY DRUM

- 1) Tip the Snowblower forward (gear box facing up) and open the guard protecting the drive shaft.
- 2) Install the mounting plate tightening the bolts lightly (Fig. 28).
- 3) Bolt hydraulic motor in place pointing the oil outlets to the exterior and install sprocket (Fig. 29).
- 4) Using the take-up screws, adjust gear to mesh without bottoming (Fig. 30).
- 5) Tighten mounting plate bolts.
- 6) It is important that the cushion valve furnished be installed. Cushion valve has been pre set in plant at 1800 psi.
- 7) Close the drive shaft guard (Fig. 31).

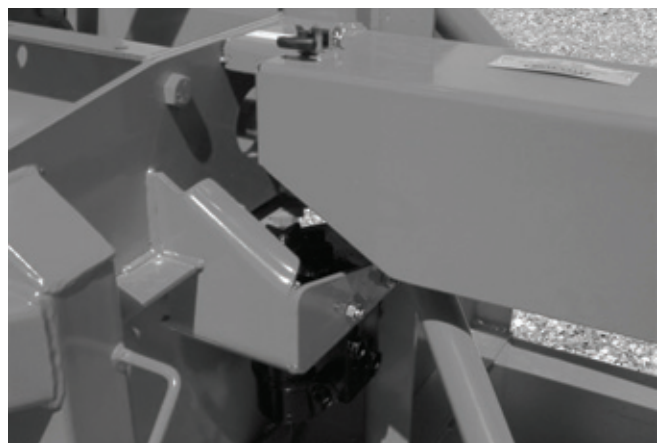

Figure 31

ASSEMBLY (cont'd)

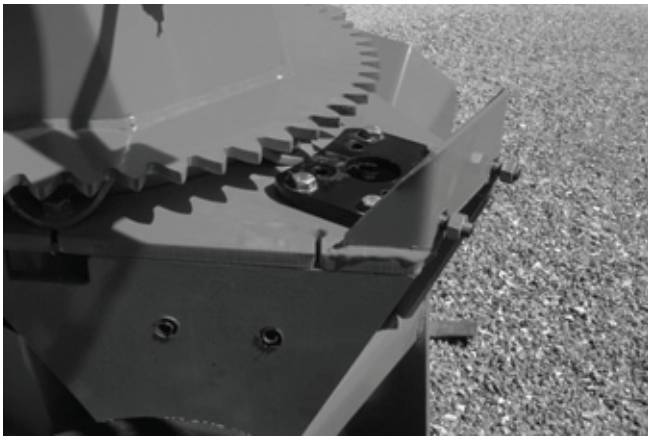

Figure 32

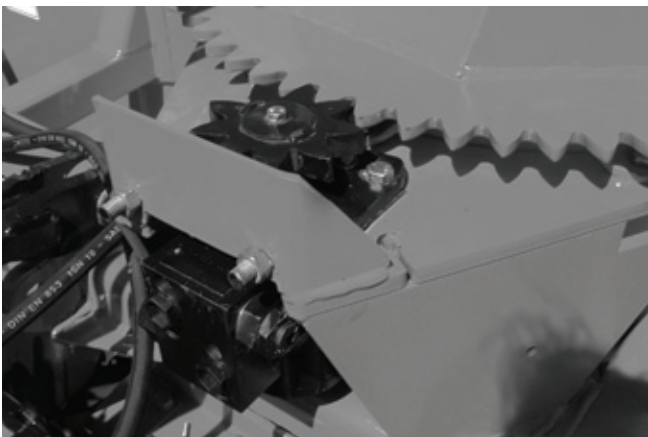

Figure 33

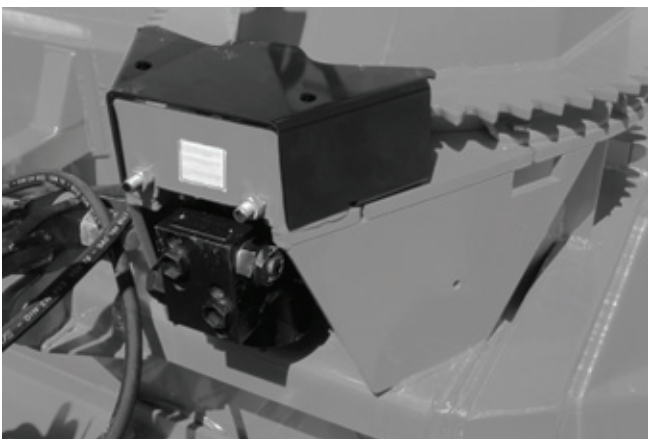

Figure 34

HYDRAULIC CHUTE ROTATION Motor

- 1) Install U-shaped UHMW piece, place chute on Snowblower and secure with retaining bracket and bolts provided.
- 2) Install the mounting plate; put the required spacers between mounting plate and base of chute (see p. 35 to 40 for chute model). Do not tighten the bolts immediately, they will be tightened at final adjustment (Fig. 32).
- 3) Install motor and 9 tooth gear. The thickness of the 9 tooth gear is slightly more than the ring-gear. Make sure it exceeds on both sides of the ring gear (Fig. 33).
- 4) Using the take-up screws, adjust gear to mesh without bottoming. Tighten mounting plate bolts.
- 5) Install guard. It is important that the cushion valve furnished with your chute rotation kit be installed. Cushion valve has been pre set in plant at 1200 psi. (Fig. 34).
- 6) If you install a hydraulic cylinder on the chute deflector, use model 25TR08 cylinder.
- 7) Use the optional hose support plate no. TSB-74104 (Fig. 35).

4



Figure 35

STARTING-UP

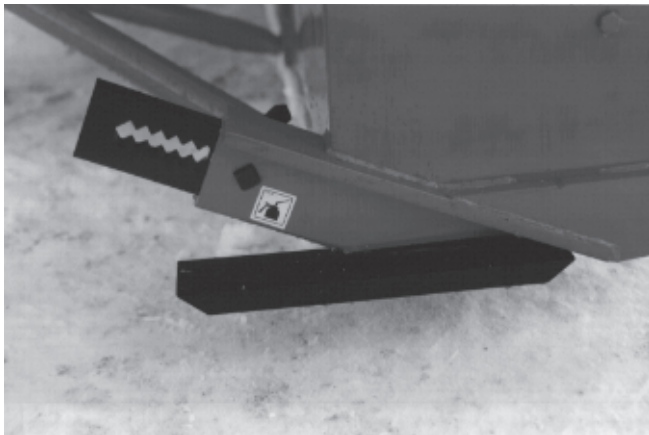

Figure 36

5

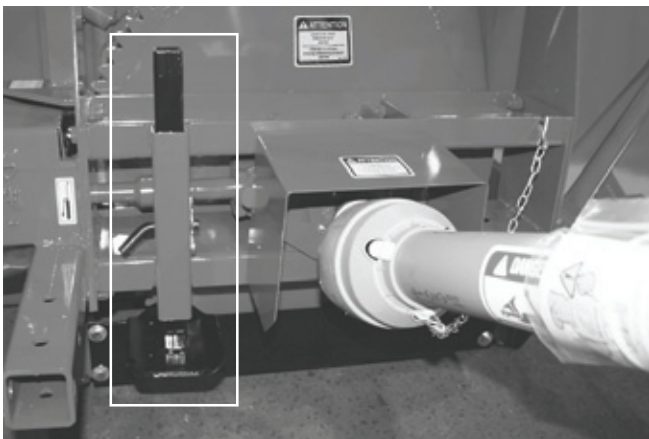

Figure 37



Figure 38

START-UP PROCEDURES

- 1) Check oil level in gearbox and in speed reducer if so equipped. Use SAE 80W90 gear box oil.
- 2) Lubricate all points with a good quality multipurpose grease.
- 3) Check chain take-up adjustment. The spring maintaining the tension must be compressed to a length between 3" and 3 1/4".
- 4) Verify for adequate tightness of all fastening devices. Refer to torque chart on page 57.
- 5) Adjust skid shoes according to ground conditions (Fig. 36).
- 6) Following the installation of the Snowblower on the tractor, **do not forget** to lift the storage support (Fig. 37).
- 7) Make sure of a 540 RPM input to your snowblower.
- 8) Check impeller adjustment. The tip of the blades should be approximately 1/8" to 3/16" from the discharge wall of the drum. If necessary, adjust with the take-up screws provided (Fig. 38).

MAINTENANCE

GENERAL MAINTENANCE

- 1) Wipe off all grease fittings with a clean cloth before adding grease in order to avoid injecting dirt and sand.
- 2) Repair or replace damaged grease fittings.
- 3) Lubricate all grease fittings every 8 hours of operation.
- 4) Lubricate drive chain every 8 hours of operation.
- 5) Lubricate P.T.O. shaft as indicated below:

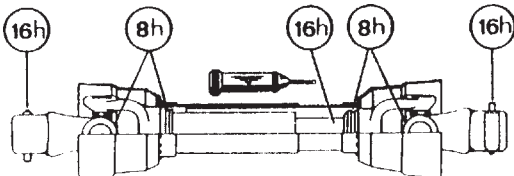

Pull out the P.T.O. And lubricate between the two tubes with low temperature grease. Drive line tubes must slide easily even in cold weather. Clean off old hardened grease and apply fresh grease as needed.

- 6) Check oil level in gear box once a month. Adjust to required oil level as per drawing in Parts List section. Use SAE 80W90 oil.
- 7) Check tension of drive chain every 24 hours of operation and adjust if necessary.
- 8) Check for tightness of bearing collars every 48 hours of operation.
- 9) Change gearbox oil once a year. Adjust to required oil level as per drawing in Parts List section. Use SAE 80W90 oil.
- 10) Check all nuts and bolts once a year. If necessary use torque chart on page 57.

- 11) Standard scraper blades are reversible. Reverse when one edge is worn out.
- 12) For the auger drive shaft, always use a grade 5 shear bolt.
- 13) For the PTO shaft:
AT 540 RPM on a PTO size 80 or 90, the shear bolt is 12 mm, grade 10.9, part number **9207**.
AT 1000 RPM, the shear bolt must be changed depending on the diameter of the bore of the shear plate of your drive line:
 - a) If the bore is 12 mm, you must use a 12 mm, grade 8.8 bolt that has been reduced to 10 mm at the point of rupture, part number **9207-375**, or
 - b) If the bore is 10 mm, you must use a 10 mm, grade 8.8 bolt, part number **8218**.

- 14) UHMW slides do not require lubrication except at the end of the season in order to prevent corrosion of steel components that are in contact with the UHMW material.

If your snowblower is equipped with the optional speed reducer

- 15) After 10 working hours, the chain's adjustment (if applicable) must be checked and every 100 working hours. Please refer to section: Maintenance on Speed Reducer (with chains).
- 16) Check oil level in speed reducer once a month. Adjust to required oil level as per drawing in Parts List section. Use ENDURATEX XL EP-68/220 oil.
- 17) Drain the oil of the speed reducer once a year. Adjust to required oil level as per drawing in Parts List section. Use ENDURATEX XL EP-68/220 oil.

STORAGE

- 1) Store the Snowblower in a cool, dry place.
- 2) Support the Snowblower with wooden blocks.
- 3) Keep all piston rods in the retracted position. This will assure better protection against the elements.
- 4) Clean your Snowblower.
- 5) Thoroughly inspect all parts of the Snowblower. Replace or repair worn or defective parts.
- 6) Touch-up or repaint if necessary.
- 7) Lubricate all points before storage.

TROUBLESHOOTING

P.T.O. SHAFT

PROBLEM	POSSIBLE CAUSE	CORRECTION
<ul style="list-style-type: none"> - Premature wear of U-joints and/ or bluish color of cross journals. 	<ul style="list-style-type: none"> - Insufficient lubrication. - Excessive working angle. - Poor quality lubricant. 	<ul style="list-style-type: none"> - Follow lubrication recommendations. - Replace defective U-joints. - Make sure the Snowblower inlet face is perpendicular to the ground and if possible readjust 3-point hitch in order to position the Snowblower further away from tractor. - Use high quality lubricant.
<ul style="list-style-type: none"> - Gripping or premature wear of telescoping members. 	<ul style="list-style-type: none"> - Too much sliding under load. - Tube overlap too-short: minimum recommended is 6". - Insufficient lubrication. - Contaminants (sand, etc.). 	<ul style="list-style-type: none"> - Avoid raising Snowblower while in operation. - Readjust 3-point hitch in order to position the Snowblower closer to the tractor. - Follow lubrication recommendations. - Replace defective telescopic members.
<ul style="list-style-type: none"> - Damaged or jammed locking pin or bolt. 	<ul style="list-style-type: none"> - Pin or orifice contaminated by sand, ice, etc. - Telescoping members too long, exerting pressure on locking device. 	<ul style="list-style-type: none"> - Clean and grease. - Readjust 3-point hitch in order to position the Snowblower further away from tractor or shorten tubes.
<ul style="list-style-type: none"> - Premature wear of guard tube bearing ring. 	<ul style="list-style-type: none"> - Lack of lubrication. - Wrong installation of guard chain. - Part of the guard in contact with the equipment. 	<ul style="list-style-type: none"> - Follow lubrication instructions. - Adjust chain to prevent interference between guard & equipment. - Replace worn or damaged bearing rings.
<ul style="list-style-type: none"> - Cut or deformed safety guard tubes. 	<ul style="list-style-type: none"> - Tubes in contact with the equipment. 	<ul style="list-style-type: none"> - Eliminate any interference between tubes and equipment or tractor. - Replace damaged tubes.

TROUBLESHOOTING (cont'd)

SNOWBLOWER

PROBLEM	POSSIBLE CAUSE	CORRECTION
- The snow is not being thrown as far as usual.	- Tractor RPM too low. - Gap too wide between impeller blade tip and drum outlet wall. - Insufficient tractor HP.	- Raise P.T.O. speed to a minimum of 540 RPM. - Adjust impeller blades closer to drum outlet (1/8" to 3/16"). - Reduce travel speed.
- Frequent plugging of discharge chute.	- Tractor RPM too low. - Tractor RPM reduced too early with snow still in the Snowblower. - Slippage of PTO clutch mechanism. - Wet snow condition.	- Raise P.T.O. speed to a minimum of 540 RPM. - Make sure the Snowblower is completely empty before reducing RPM, especially on tractors with foot controlled RPM. - Repare clutch. - Reduce travel speed. - Remove the chute access panel.
- The impeller will not turn.	- Shear bolt broken on drive shaft.	- Replace shear bolt.
- The auger will not turn.	- Shear bolt broken on drive shaft. - Shear bolt broken on auger drive shaft. - Broken drive chain. - Broken key on motor.	- Replace shear bolt. - Replace shear bolt. - Fix or replace chain. - Replace the key.
- The rotating drum will not turn.	- Ice accumulation. - Wrong hydraulic connections. - Broken key on motor.	- Remove ice. - Check hydraulic connections. - Replace the key.
- The rotating drum will not hold it's position when blowing via the spout	- Cushion valve setting too low - Tension of the spring in drum locking mechanism insufficient	- Reset cushion valve up to 1800 psi (max) - Increase tension of spring by adding shim(s)
- The chute will not turn.	- Ice accumulation. - Wrong hydraulic connections. - Broken key on motor.	- Remove ice. - Check hydraulic connections. - Replace the key.

SPECIFICATIONS

		GROUP III			
Snowblower model		P-992	P-980	P-1020	P-1040
Snowblower model		P-992 TRC	P-980 TRC	P-1020 TRC	P-1040 TRC
Horse power recommended (HP)	min.-max.	85 to 125	100 to 150	100 to 150	100 to 150
Working width	po. - (cm)	92"(234)	98" (249)	102 (259)	104 (264)
Cutting height	po. - (cm)	44" (112)	48" (122)	48" (122)	48" (122)
Height - Chute base	po. - (cm)	44 3/8" (112.7)	47 3/4" (121.3)	47 3/4" (121.3)	47 3/4" (121.3)
Height - chute base, TRC model	po. - (cm)	45" (114.3)	48 3/4" (123.8)	48 3/4" (123.8)	48 3/4" (123.8)
Impeller diameter	po. - (cm)	30" (76)	34" (86)	34" (86)	34" (86)
Depth of drum	po. - (cm)	15" (38.1)	15" (38.1)	15" (38.1)	15" (38.1)
Impeller blades		5	6	6	6
Size of impeller shaft	po. - (cm)	2"	2"	2"	2"
Height - Impeller center	po. - (cm)	20" (50.8)	21 1/2" (54.6)	21 1/2" (54.6)	21 1/2" (54.6)
Impeller RPM		540	540	540	540
Number of augers		1	1	1	1
Main auger diameter	po. - (cm)	23" (58)	26" (66)	26" (66)	26" (66)
Upper auger 14" (35.6 cm) diameter		Opt.	Opt.	Opt.	Opt.
Drivechain - Main auger		80	100	100	100
Oil bath sealed gear box		Std.	Std.	Std.	Std.
Chute rotation mechanism	Manual	-	-	-	-
	Hydraulic (motor)	Std.	Std.	Std.	Std.
Number of shear bolts		2	2	2	2
Hitch category		2	2	2	2
Balanced impeller		Std.	Std.	Std.	Std.
Balanced auger		Std.	Std.	Std.	Std.
Drum rotation mechanism for hyd. motor		Std.	Std.	Std.	Std.
1000 to 540 RPM reducer		Opt.	Opt.	Opt.	Opt.
Scrapper blade	Std. steel - reversible 1/2" x 4"	Std.	Std.	Std.	Std.
	Acier carbone - reversible 1/2" x 4"	Opt.	Opt.	Opt.	Opt.
	Acier carbone - sharpened 1/2" x 6"	Opt.	Opt.	Opt.	Opt.
	Tivar	Opt.	Opt.	Opt.	Opt.
	Stainless steel - reversible 1/2" x 4"	Opt.	Opt.	Opt.	Opt.
Skid shoes	Standard steel	Std.	Std.	Std.	Std.
	Carbon steel	Opt.	Opt.	Opt.	Opt.
	Stainless steel	Opt.	Opt.	Opt.	Opt.
Full flight auger (industrial)		Opt.	Opt.	Opt.	Opt.
Chute	regular	Opt.	Opt.	Opt.	Opt.
	semi-industrial	Opt.	Opt.	Opt.	Opt.
	indust. quick attach - extension 24" or 48"	Opt.	Opt.	Opt.	Opt.
	industrial telescopic	-	-	-	-
Deflector	manual	Opt.	Opt.	Opt.	Opt.
	hydraulic	Opt.	Opt.	Opt.	Opt.
Bearing / ductile iron casting		Std.	Std.	Std.	Std.
Lateral blades		Opt.	Opt.	Opt.	Opt.
P.T.O.	(standard)	No. 8	No. 8	No. 8	No. 8
P.T.O.	(optional)	No. 9	No. 9	No. 9	No. 9
Weight (approx)	lbs - kg	1970 (895)	2038 (926)	2050 (932)	2058 (935)
	lbs - kg	2135 (970)	2250 (1023)	2264 (1029)	2270 (1032)

Design and specifications subject to change without notice.

 Shaded lines apply only to models with rotary drum (TRC).

SNOWBLOWER P-992

170-03777

See upper auger components on page 47.

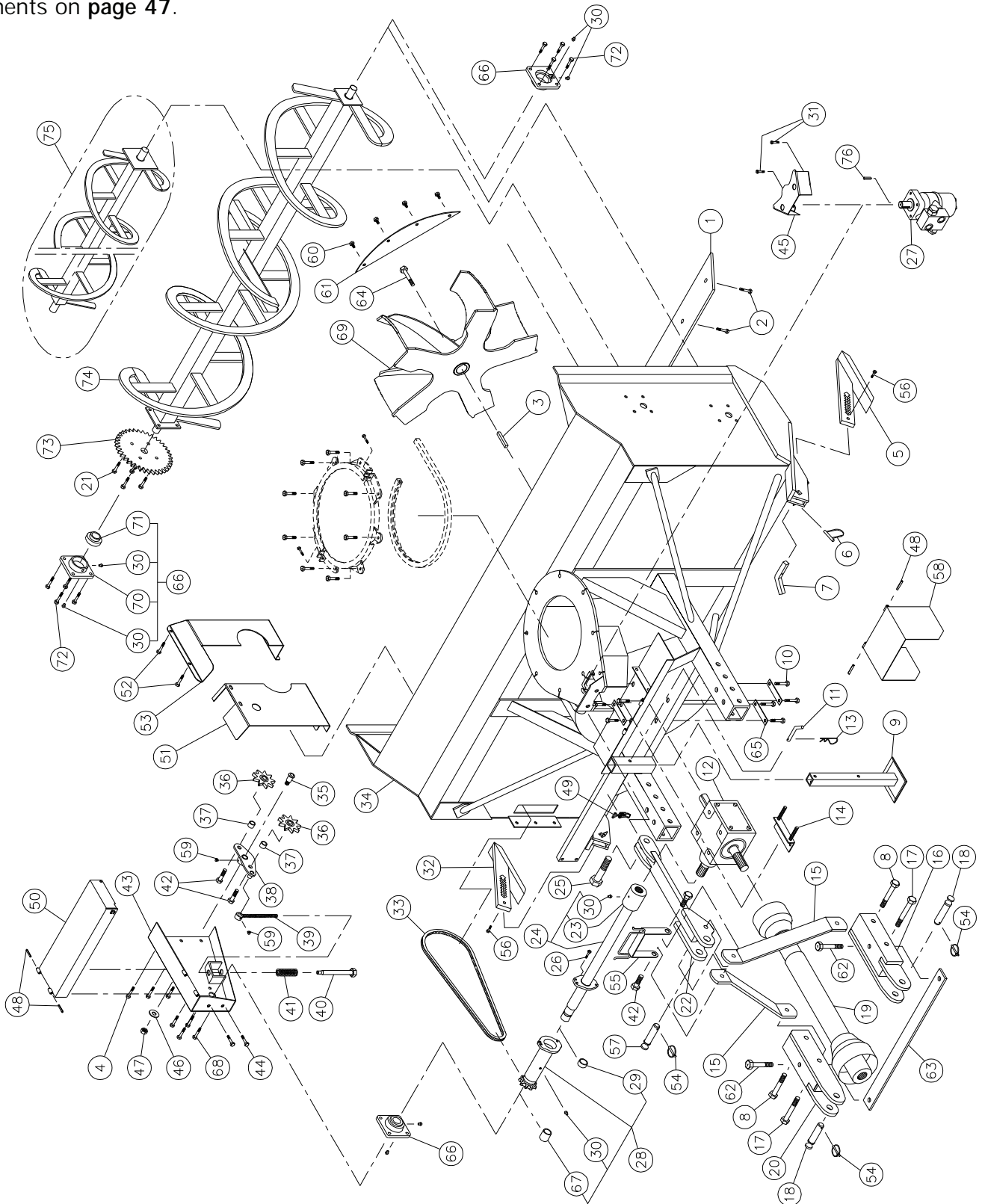

SNOWBLOWER P-992 (cont'd)

REF.	PART #	DESCRIPTION	QTY
1	140-00812	Reversible scraper blade 1/2" x 4" x 84 1/2" lg	1
2	319-38310	Plow bolt 7/16" NC x 1 1/2" lg + nut & lock washer	9
3	9285	Square key 1/2" x 1/2" x 4" lg	1
4	300-38250	Bolt 7/16" NC x 1" lg + nylon locknut & flat washer 3/8"	3
5	110-04531	Skid shoe (right side)	1
6	8112	Lock pin 1/4"	2
7	140-03361	Skid shoes lock	2
8	302-46580	Bolt 3/4" NF x 6" lg + nylon locknut	2
9	9462	Storage support	1
10	300-44310	Bolt 5/8" NC x 1 1/2" lg + lock washer	8
11	8220	Storage support pin	1
12	9307	Gear box T-279	1
13	Std.	Hitch pin clip 5/32"	1
14	9428	Adjustment plate for gear box + 4 nuts 1/2" NC	1
15	140-05493	3-point side bar	2
16	110-15214	Right lower hitch	1
17	302-46610	Bolt 3/4" NF x 6 1/2" lg + nylon locknut	2
18	9269	Pin category 2	2
19	9225-EG	P.T.O. shaft T80	1
19	9475	P.T.O. shaft T90	opt.
20	110-15213	Left lower hitch	1
21	301-38310	Bolt 7/16" NC x 1 1/2" lg + two-way locknut	4
22	110-15421	Upper hitch	1
23	6467	Splined adaptor 1 3/4" - 20 (welded)	1
24	110-18252	Auger drive shaft 34 7/16" lg overall (includes no. 23 and 27)	1
25	300-54460	Bolt 1 1/4" NC x 4" lg + nylon locknut	1
26	300-34310	Bolt 5/16" NC x 1 1/2" lg grade 5 + nylon locknut	1
27	MLH-250	Hydraulic "Orbit" motor + cushion valve	opt.
27	MLH-315	"Orbit" hydraulic motor + cushion valve	opt.
28	110-18242	Sprocket 80B10 + shearplate (including #29, 30 & 67)	1
29	160-06901	Brass bushing 1 3/4" i.d. x 2" o.d. x 1/2" lg	1
30	Std.	Grease fitting 1/4"-28 straight	12
31	300-34280	Bolt 5/16" NC x 1 1/4" lg + nylon locknut	2
32	110-04521	Skid shoe (left side)	1
33	190-01451	Chain # 80 x 85" lg (85 links)	1
33	26A80	Connecting link no. 80	1
33	59-80	Offset link no. 80	1
34	120-07891	Frame P-992	1
35	150-00332	Idler clevis pin	1
36	9287	Idler sprocket # 80	2
37	160-06511	Spacer 3/4" i.d. x 1 1/4" o.d. x 3/4" lg	2
38	110-01052	Idler	1
39	110-01063	Threaded rod for idler adjustment + nut 7/16" NC	1
40	110-01071	Threaded tube for idler adjustment	1
41	9688	Compression spring	1
42	302-46400	Bolt 3/4" NC x 3" lg + nylon locknut	4
43	110-01604	Chain guard	1
44	300-38250	Bolt 7/16" NC x 1" lg + nylon locknut	2
45	130-14282	Guard	1
46	376-44000	Flat washer 5/8"	1
47	346-45000	Nylon locknut 5/8" NC (thin)	1
48	Std.	Roll pin 5/16" x 2" lg	4
49	8374	Adjustable clamp fastener (welded)	1
50	110-21001	Auger drive shaft guard	1
51	130-85161	Inside guard (welded) (up to serial # 33946)	1
51	130-85162	Inside guard (welded) (from serial # 33947 and up)	1
52	301-36250	Bolt 3/8" NC x 1" lg + nylon locknut & flat washer	4
53	130-85171	Inside guard (bolted)	1

SNOWBLOWER P-992 (cont'd)

REF.	PART #	DESCRIPTION	QTY
54	Std.	Lynch pin 1/4" X 1 3/4"	3
55	110-15201	Hoses support	1
56	300-32310	Bolt 1/4" NC x 1 1/2" lg + nylon locknut	2
57	150-05961	Pin category 2 (top link)	1
58	110-12541	Hinged P.T.O. shroud	1
59	Std.	Grease fitting 1/4"-28 90 deg.	2
60	301-38280	Bolt 7/16" NC x 1 1/4" lg + nylon locknut	4
61	130-02111	Deflector	1
62	302-46550	Bolt 3/4" NF x 5 1/2" lg + nylon locknut	2
63	140-03441	3-point hitch reinforcement	1
64	8228	Impeller cap screw 5/8" NC x 1 1/2" lg (assembled with locktite 242) + lock washer	1
65	160-10761	Back plate	3
66	UCFD208-24	Bearing 1 1/2" + flange & 2 grease fittings (straight)	3
67	160-07311	Bushing 1 1/2" i.d. x 1 7/8" o.d. x 1 1/4" lg	1
68	301-40310	Bolt 1/2" NC x 1 1/2" lg + nylon locknut (thin) & flat washer 7/16"	4
69	110-01613	Impeller 30" ø - 5 blades	1
70	FD208	Flange for 2 grease fitting	3
71	UC208-24	Bearing 1 1/2"	3
72	302-40325	Bolt 1/2" NC x 1 3/4" lg + nylon locknut & flat washer 7/16"	8
73	9281	Sprocket 80A30 T 1 1/2" ø	1
74	110-02061	Lower auger P-992 (TRC)	1
75	VS2-992	Upper auger P-992 and components (TRC) (see p. 47)	opt.
76	8369	Key for "Orbit" motor	opt.

SNOWBLOWER P-992TRC

170-04955

See upper auger components on page 47.

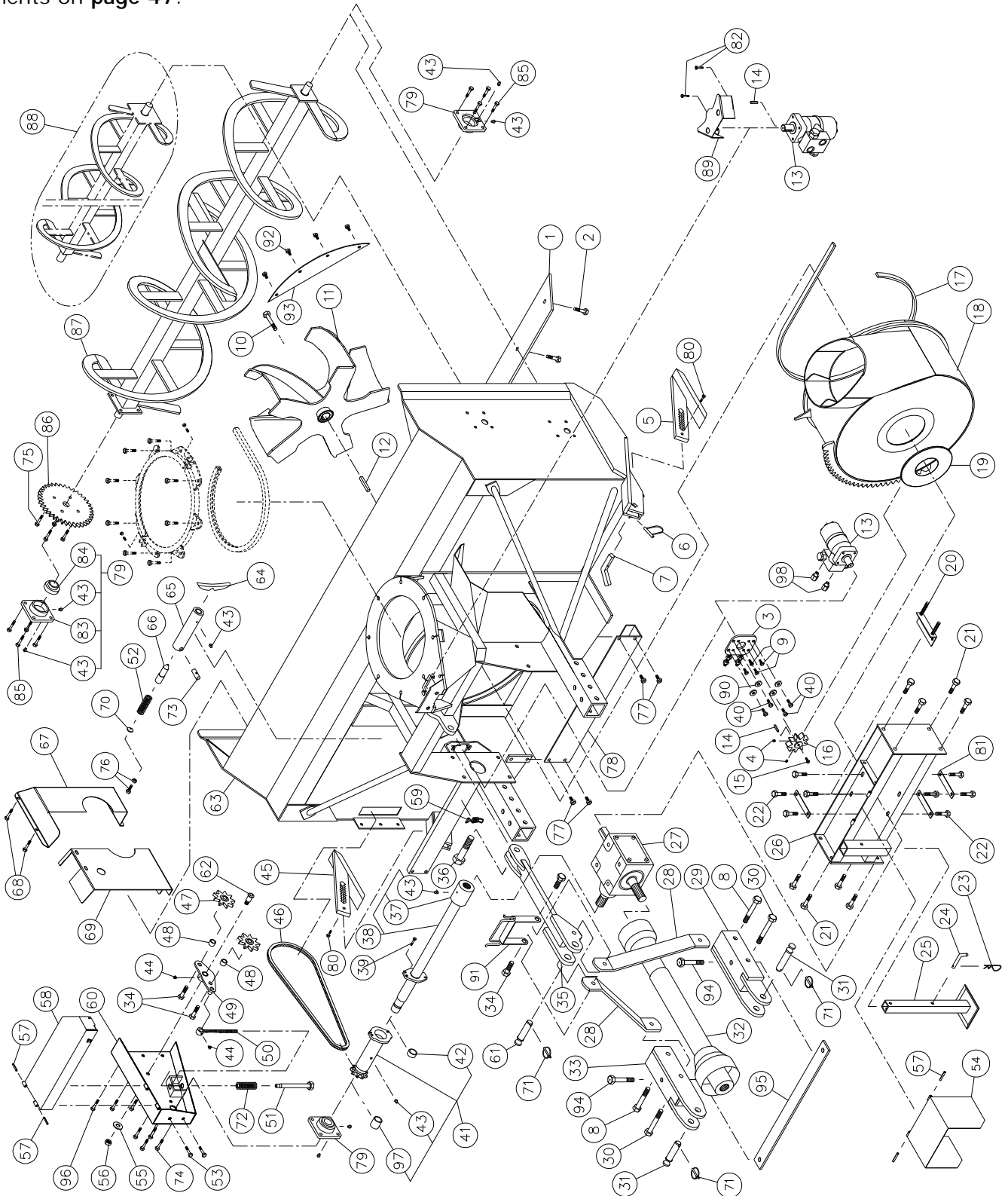

SNOWBLOWER P-992TRC (cont'd)

REF.	PART #	DESCRIPTION	QTY
1	140-00812	Reversible scraper blade 1/2" x 4" x 84 1/2" lg	1
2	319-38310	Plow bolt 7/16" NC x 1 1/2" lg + nut & lock washer	9
3	110-18441	Orbit motor support + 4 nuts 7/16" NC	1
4	323-36160	Hexagonal socket set screw 3/8" NC x 3/8" lg	2
5	110-04531	Skid shoe (right side)	1
6	8112	Lock pin 1/4"	2
7	140-03361	Skid shoes lock	2
8	302-46580	Bolt 3/4" NF x 6" lg + nylon locknut	2
9	301-36250	Bolt 3/8" NC x 1" lg + lock washer	4
10	8228	Impeller cap screw 5/8" NC x 1 1/2" lg (assembled with locktite 242) + lock washer	1
11	110-01613	Impeller 30" ø 5 blades	1
12	9285	Square key 1/2" x 1/2" x 4" lg	1
13	MLH-250	Hydraulic "Orbit" motor + cushion valve	opt.
13	MLH-315	Hydraulic "Orbit" motor + cushion valve	opt.
14	8369	Key (2)	opt.
15	301-32220	Bolt 1/4" NC x 3/4" lg + lock washer	1
16	110-44331	Sprocket (9 teeth)	1
17	9435	U-shaped UHMW 3/8" x 7/8" x 97" lg	1
18	110-12843	Rotary drum 30" ø	1
19	9432	UHMW flat washer 3/16" x 8 7/8" i.d. x 12" o.d.	1
20	9428	Adjustment plate for gear box+ 4 nuts 1/2" NC	1
21	301-46340	Bolt 3/4" NC x 2" lg + nylon locknut	8
22	300-44310	Bolt 5/8" NC x 1 1/2" lg + lock washer	8
23	Std.	Hitch pin clip 5/32"	1
24	8220	Storage support pin	1
25	9462	Storage support	1
26	9437	Gear box support	1
27	9307	Gear box T-279	1
28	140-05472	3-point side bar	2
29	110-15214	Right lower hitch	1
30	302-46610	Bolt 3/4" NF x 6 1/2" lg + nylon locknut	2
31	9269	Pin category 2	2
32	9225-EG	P.T.O. shaft T80	1
32	9475	P.T.O. shaft T90	opt.
33	110-15213	Left lower hitch	1
34	302-46400	Bolt 3/4" NC x 3" lg + nylon locknut	4
35	110-15531	Upper hitch	1
36	300-54460	Bolt 1 1/4" NC x 4" lg + nylon locknut	1
37	6467	Splined adaptor 1 3/4" - 20 (welded)	1
38	110-18252	Auger drive shaft 34 1/8" lg overall (including no. 37 & 43)	1
39	300-34310	Bolt 5/16" NC x 1 1/2" lg grade 5 + nylon locknut	1
40	300-38310	Bolt 7/16" NC x 1 1/2" + nylon locknut	4
41	110-18242	Sprocket 80B10 + shearplate (including #42, 43 & 97)	1
42	160-06901	Brass bushing 1 3/4" i.d. x 2" o.d. x 1/2" lg	1
43	Std.	Grease fitting 1/4"-28 straight	9
44	Std.	Grease fitting 1/4"-28 90 deg.	2
45	110-04521	Skid shoe (left side)	1
46	190-01451	Chain #80 x 85" lg (85 links)	1
46	26A80	Connecting link no. 80	1
47	9287	Idler sprocket #80	2
48	160-06511	Spacer 3/4" i.d. x 1 1/4" o.d. x 3/4" lg	2
49	110-01052	Idler	1
50	110-01063	Threaded rod for idler adjustment + nut 7/16" NC	1
51	110-01071	Threaded tube for idler adjustment	1
52	9473	Compression spring	1
53	300-38250	Bolt 7/16" NC x 1" lg + nylon locknut	2
54	110-12541	Hinged P.T.O. shroud	1
55	376-44000	Flat washer 5/8"	1
56	346-45000	Nylon locknut 5/8" NC (thin)	1
57	Std.	Roll pin 5/16" x 2" lg	4
58	110-21011	Auger drive shaft guard	1

SNOWBLOWER P-992TRC (cont'd)

REF.	PART #	DESCRIPTION	QTY
59	8374	Adjustable clamp fastener (welded)	1
60	110-01604	Chain guard	1
61	150-05961	Pin category 2 (top link)	1
62	150-00332	Idler clevis pin	1
63	120-02739	Frame P-992TRC	1
64	130-08441	Stop block for drum lock (welded on drum)	1
65	160-03952	Body - drum lock (welded on frame)	1
66	150-01542	Latch pin - drum lock	1
67	130-85171	Inside guard (bolted)	1
68	300-36250	Bolt 3/8" NC x 1" lg + nylon locknut & flat washer	4
69	130-85161	Inside guard (welded) (up to serial # 33946)	1
69	130-85162	Inside guard (welded) (from serial # 33947 and up)	1
70	130-08471	Washer	1
71	Std.	Lynch pin 1/4" X 1 3/4"	2
72	9688	Compression spring	1
73	150-02561	Pin	1
74	300-40310	Bolt 1/2" NC x 1 1/2" lg + nylon locknut (thin) & flat washer 7/16"	4
75	300-38310	Bolt 7/16" NC x 1 1/2" lg + two-way locknut	4
76	300-38341	Bolt 7/16" NC x 2" lg + jam nut	1
77	300-40280	Bolt 1/2" NC x 1 1/4" lg + nylon locknut + flat washer	4
78	130-06561	Guard for ring gear segment	1
79	UCFD208-24	Bearing 1 1/2" + flange & 2 grease fittings (straight)	3
80	300-32310	Bolt 1/4" NC x 1 1/2" lg + nylon locknut	2
81	140-10761	Back plate	3
82	300-34280	Bolt 5/16" NC x 1 1/4" lg + nylon locknut	2
83	FD208	Flange for 2 grease fitting	3
84	UC208-24	Bearing 1 1/2" UC208-24	3
85	300-40325	Bolt 1/2" NC x 1 3/4" lg + nylon locknut & flat washer 7/16"	8
86	9281	Sprocket 80A30 T 1 1/2" ø	1
87	110-02061	Lower auger P-992 (TRC)	1
88	VS2-992	Upper auger P-992 and components (TRC) (see p. 47)	opt.
89	130-14282	Guard	1
90	150-12741	Flat washer 7/16" heavy-duty	4
91	110-15201	Hoses support	1
92	300-38280	Bolt 7/16" NC x 1 1/4" lg + nylon locknut	4
93	130-02111	Deflector	1
94	302-46550	Bolt 3/4" NF x 5 1/2" lg + nylon locknut	2
95	140-03441	3-point hitch reinforcement	1
96	300-38250	Bolt 7/16" NC x 1" lg + nylon locknut & flat washer 3/8"	3
97	160-07311	Bushing 1 1/2" i.d. x 1 7/8" o.d. x 1 1/4" lg	1
98	RSP-1/16x10 ORB	Ensemble de 2 restricteurs unidirectionnels	opt.

SNOWBLOWERS P-980 P-1020 P-1040

170-03785

See upper auger components on page 47.

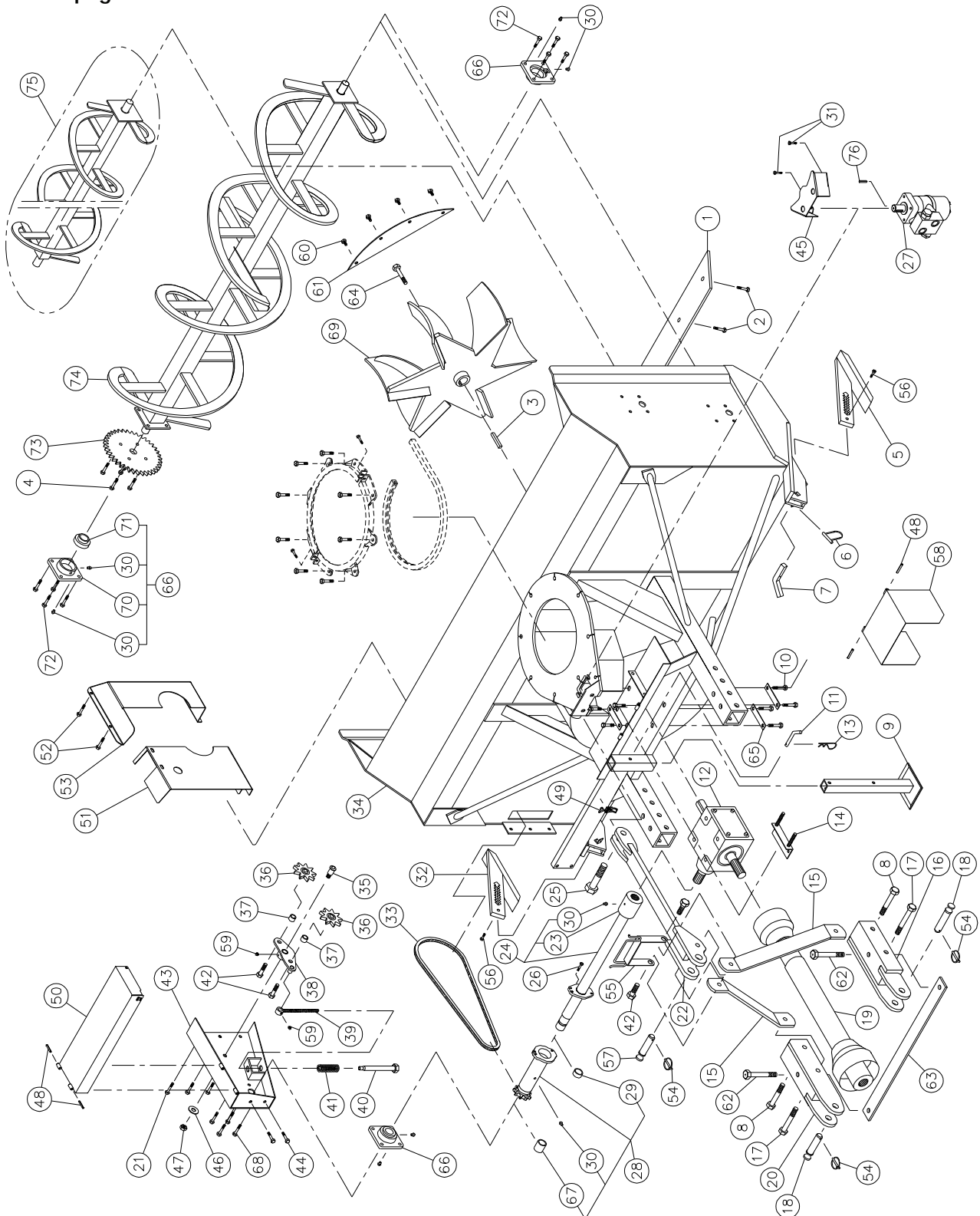

SNOWBLOWERS P-980 P-1020 P-1040 (cont'd)

REF.	PART #	DESCRIPTION	QTY		
			P-980	P-1020	P-1040
1	140-00832	Reversible scraper blade 1/2" x 4" x 90 1/2" lg	1	-	-
1	140-15151	Reversible scraper blade 1/2" x 4" x 95" lg	-	1	-
1	140-00852	Reversible scraper blade 1/2" x 4" x 97" lg	-	-	1
2	319-38310	Plow bolt 7/16" NC x 1 1/2" lg + nut & lock washer	9	10	10
3	9285	Square key 1/2" x 1/2" x 4" lg	1	1	1
4	300-38325	Bolt 7/16" NC x 1 3/4" lg + two way locknut	4	4	4
5	110-04531	Skid shoe (right side)	1	1	1
6	8112	Lock pin 1/4"	2	2	2
7	140-03361	Skid shoes lock	2	2	2
8	302-46580	Bolt 3/4" NF x 6" lg + nylon locknut	2	2	2
9	9462	Storage support	1	1	1
10	300-44310	Bolt 5/8" NC x 1 1/2" lg + lock washer	8	8	8
11	8220	Storage support pin	1	1	1
12	9307	Gear box T-279	1	1	1
13	Std.	Hitch pin clip 5/32"	1	1	1
14	9428	Adjustment plate for gear box + 4 nut 1/2" NC	1	1	1
15	140-05592	3-point side bar	2	2	2
16	110-15214	Right lower hitch	1	1	1
17	302-46610	Bolt 3/4" NF x 6 1/2" lg + nylon locknut	2	2	2
18	9269	Pin category 2	3	3	3
19	9225-EG	P.T.O. shaft T80	1	1	1
19	9475	P.T.O. shaft T90	opt.	opt.	opt.
20	110-15213	Left lower hitch	1	1	1
21	300-38250	Bolt 7/16" NC x 1" lg + nylon locknut & flat washer 3/8"	3	3	3
22	110-15421	Upper hitch	1	1	1
23	6467	Splined adaptor 1 3/4" - 20 (welded)	1	1	1
24	110-14382	Auger drive shaft 37 7/16" lg overall (including no. 23 & 30)	1	-	-
24	110-25022	Auger drive shaft 39 7/16" lg overall (including no. 23 & 30)	-	1	-
24	110-15002	Auger drive shaft 40 7/16" lg overall (including no. 23 & 30)	-	-	1
25	300-54460	Bolt 1 1/4" NC x 4" lg + nylon locknut	1	1	1
26	300-36310	Bolt 3/8" NC x 1 1/2" lg grade 5 + nylon locknut	1	1	1
27	MLH-250	"Orbit" hydraulic motor + cushion valve	opt.	opt.	opt.
27	MLH-315	"Orbit" hydraulic motor + cushion valve	opt.	opt.	opt.
28	110-14572	Sprocket 100B9 + shearplate (including # 29, 30 & 67)	1	1	1
29	160-06901	Bushing 1 3/4" i.d. x 2" o.d. x 1/2" lg	1	1	1
30	Std.	Grease fitting 1/4"-28 straight	8	8	8
31	300-34280	Bolt 5/16" NC x 1 1/4" lg + nylon locknut	2	2	2
32	110-04521	Skid shoe (left side)	1	1	1
33	190-01461	Chain # 100 x 88 3/4" lg (72 rollers)	1	1	1
33	26A100	Connecting link no. 100	1	1	1
34	120-02699	Frame P-980	1	-	-
34	120-04884	Frame P-1020	-	1	-
34	120-02719	Frame P-1040	-	-	1
35	150-00332	Idler clevis pin	1	1	1
36	9470	Idler sprocket # 100	2	2	2
37	160-06511	Spacer 3/4" d.i. x 1 1/4" o.d. x 3/4" lg	2	2	2
38	110-01052	Idler	1	1	1
39	110-01063	Threaded rod for idler adjustment + nut 7/16" NC	1	1	1
40	110-01071	Threaded tube for idler adjustment	1	1	1
41	9688	Compression spring	1	1	1
42	302-46400	Bolt 3/4" NC x 3" lg + nylon locknut	2	2	2
43	110-01604	Chain guard	1	1	1
44	300-38250	Bolt 7/16" NC x 1" lg + nylon locknut	2	2	2
45	130-14282	Guard	1	1	1
46	376-44000	Flat washer 5/8"	1	1	1
47	346-45000	Nylon locknut 5/8" NC (thin)	1	1	1

SNOWBLOWERS P-980 P-1020 P-1040 (cont'd)

REF.	PART #	DESCRIPTION	QTY		
			P-980	P-1020	P-1040
48	Std.	Roll pin 5/16" x 2" lg	4	4	4
49	8374	Adjustable clamp fastener (welded)	1	1	1
50	110-16512	Auger drive shaft guard	1	-	-
50	110-25011	Auger drive shaft guard	-	1	-
50	110-16522	Auger drive shaft guard	-	-	1
51	130-01373	Inside guard (welded)	1	1	1
52	300-36250	Bolt 3/8" NC x 1" lg + nylon locknut & flat washer	4	4	4
53	130-85971	Inside guard (bolted)	1	1	1
54	Std.	Lynch pin 1/4" x 1 3/4"	3	3	3
55	110-15201	Hoses support	1	1	1
56	300-32310	Bolt 1/4" NC x 1 1/2" lg + nylon locknut	2	2	2
57	150-05961	Pin category 2 (top link)	1	1	1
58	110-12541	Hinged P.T.O. shroud	1	1	1
59	Std.	Grease fitting 1/4"-28 90 deg.	2	2	2
60	300-38280	Bolt 7/16" NC x 1 1/4" lg + nylon locknut	4	4	4
61	130-05911	Deflector	1	1	1
62	302-46550	Bolt 3/4" NF x 5 1/2" lg + nylon locknut	2	2	2
63	140-03561	3-point hitch reinforcement	1	1	1
64	8228	Impeller cap screw 5/8" NC(assembled with locktite 242) x 1 1/2" lg + lock washer	1	1	1
65	140-10761	Back plate	3	3	3
66	UCFD208-24	Bearing 1 1/2" + flange & 2 grease fittings (straight)	3	3	3
67	160-06891	Bushing 1 3/4" i.d. x 1 15/16" o.d. x 1 1/4" lg	1	1	1
68	300-40310	Bolt 1/2" NC x 1 1/2" lg + nylon locknut (thin) & flat washer 7/16"	4	4	4
69	110-01623	Impeller 34" ø - 15" depth - 6 blades	1	1	1
70	FD208	Flange for 2 grease fitting	3	3	3
71	UC208-24	Bearing 1 1/2" UC208-24	3	3	3
72	300-40325	Bolt 1/2" NC x 1 3/4" lg + nylon locknut & flat washer 7/16"	8	8	8
73	9471	Sprocket 100A24 T 1 1/2" ø	1	1	1
74	110-02702	Lower auger P-980 (TRC)	1	-	-
74	110-25032	Lower auger P-1020 (TRC)	-	1	-
74	110-02712	Lower auger P-1040 (TRC)	-	-	1
75	VS2-980	Upper auger P-980 (TRC) and components (see p. 47)	opt.	-	-
75	VS2-1020	Upper auger P-1020 (TRC) and components (see p. 47)	-opt.	-	-
75	VS2-1040	Upper auger P-1040 (TRC) and components (see p. 47)	-	-opt.	-
76	8369	Clé du moteur Orbit	opt.	opt.	opt.

SNOWBLLOWERS P-980TRC P-1020TRC P-1040TRC

170-05423

See upper auger components on page 47.

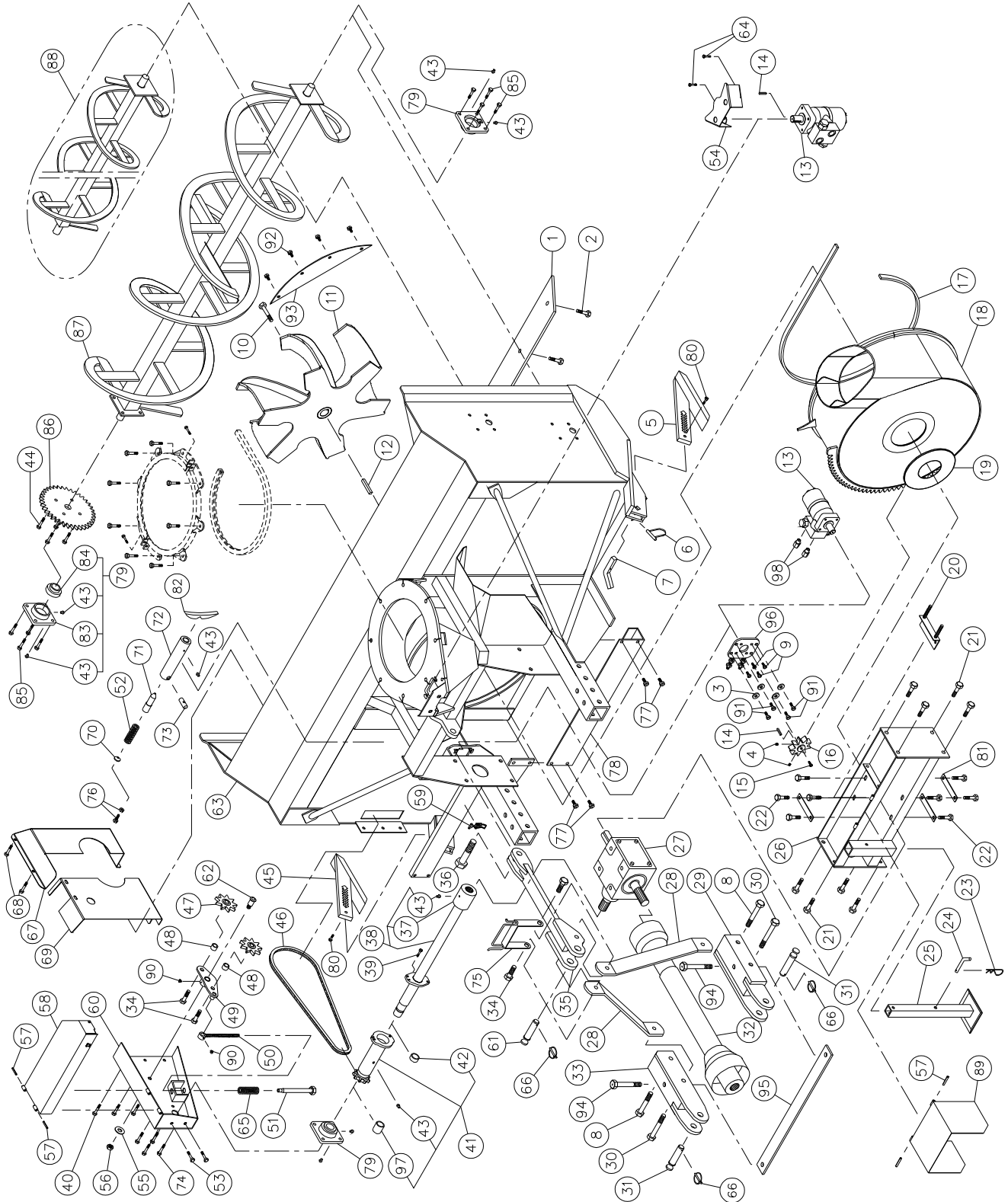

SNOWBLOWERS P-980TRC P-1020TRC P-1040TRC (cont'd)

REF.	PART #	DESCRIPTION	QTY		
			P-980TRC	P-1040TRC	P-1040TRC
1	140-00832	Reversible scraper blade 1/2" x 4" x 90 1/2" lg	1	-	-
1	140-15151	Reversible scraper blade 1/2" x 4" x 95" lg	-	1	-
1	140-00852	Reversible scraper blade 1/2" x 4" x 97" lg	-	-	1
2	319-38310	Plow bolt 7/16" NC x 1 1/2" lg + nut & lock washer	9	10	10
3	150-12741	Flat washer 7/16" heavy-duty	4	4	4
4	323-36160	Hexagonal socket set screw 3/8" NC x 3/8" lg	2	2	2
5	110-04531	Skid shoe (right side)	1	1	1
6	8112	Safety square pin 3.5 mm x 84 mm	2	2	2
7	140-03361	Skid shoes lock	2	2	2
8	302-46580	Bolt 3/4" NF x 6" lg + nylon locknut	2	2	2
9	301-36250	Bolt 3/8" NC x 1" lg + lock washer	4	4	4
10	8228	Impeller cap screw 5/8" NC x 1 1/2" lg (assembled with locktite 242) + lock washer	1	1	1
11	110-01623	Impeller 34" ø 6 blades	1	1	1
12	9285	Square key 1/2" x 1/2" x 4" lg	1	1	1
13	MLH-250	Hydraulic "Orbit" motor + cushion valve	opt.	opt.	opt.
13	MLH-315	Hydraulic "Orbit" motor + cushion valve	opt.	opt.	opt.
14	8369	Key	opt.	opt.	opt.
15	301-32220	Bolt 1/4" NC x 3/4" lg + lock washer	1	1	1
16	110-44331	Sprocket (9 teeth)	1	1	1
17	9430	U-shaped UHMW 3/8" x 7/8" x 109 1/4" lg	1	1	1
18	110-12855	Rotary drum 34" ø	1	1	1
19	9432	UHMW flat washer 3/16" x 8 7/8" i.d. x 12" o.d.	1	1	1
20	9428	Adjustment plate for gear box + 4 nuts 1/2" NC	1	1	1
21	301-46340	Bolt 3/4" NC x 2" lg + nylon locknut	8	8	8
22	300-44310	Bolt 5/8" NC x 1 1/2" lg + lock washer	8	8	8
23	Std.	Hitch pin clip 5/32"	1	1	1
24	8220	Storage support pin	1	1	1
25	9462	Storage support	1	1	1
26	9433	Gear box support	1	1	1
27	9307	Gear box T-279	1	1	1
28	140-05592	3-point side bar	2	2	2
29	110-15214	Right lower hitch	1	1	1
30	302-46610	Bolt 3/4" NF x 6 1/2" lg + nylon locknut	2	2	2
31	9269	Pin category 2	2	2	2
32	9225-EG	P.T.O. shaft T80	1	1	1
32	9475	P.T.O. shaft T90	opt.	opt.	opt.
33	110-15213	Left lower hitch	1	1	1
34	300-46400	Bolt 3/4" NC x 3" lg + nylon locknut	4	4	4
35	110-15531	Upper hitch	1	1	1
36	300-54460	Bolt 1 1/4" NC x 4" lg + nylon locknut	1	1	1
37	6467	Splined adaptor 1 3/4" - 20 (welded)	1	1	1
38	110-14382	Auger drive shaft 37 7/16" lg overall (including no. 37 & 43)	1	-	-
38	110-25022	Auger drive shaft 39 7/16" lg overall (including no. 37 & 43)	-	1	-
38	110-15002	Auger drive shaft 40 7/16" lg overall (including no. 37 & 43)	-	-	1
39	300-36310	Bolt 3/8" NC x 1 1/2" lg grade 5 + nylon locknut	1	1	1
40	300-38250	Bolt 7/16" NC x 1" lg + nylon locknut & flat washer 3/8"	3	3	3
41	110-14572	Sprocket 100B9 + shearplate (including # 42, 43 & 97)	1	1	1
42	160-06901	Brass bushing 1 3/4" i.d. x 2" o.d. x 1 1/2" lg	1	1	1
43	Std.	Grease fitting 1/4"-28 straight	9	9	9
44	300-38325	Bolt 7/16" NC x 1 3/4" lg + two way locknut	4	4	4
45	110-04521	Skid shoe (left side)	1	1	1

SNOWBLOWERS P-980TRC P-1020TRC P-1040TRC (cont'd)

REF.	PART #	DESCRIPTION	QTY		
			P-980TRC	P-1020TRC	P-1040TRC
46	190-01461	Chain #100 x 88 3/4" lg (71 rollers)	1	1	1
46	26A100	Connecting link no. 100	1	1	1
47	9470	Idler sprocket #100	2	2	2
48	160-06511	Spacer 3/4" i.d. x 1 1/4" o.d. x 3/4" lg	2	2	2
49	110-01052	Idler	1	1	1
50	110-01063	Threaded rod for idler adjustment + nut 7/16" NC	1	1	1
51	110-01071	Threaded tube for idler adjustment	1	1	1
52	9473	Compression spring	1	1	1
53	300-38250	Bolt 7/16" NC x 1" lg + nylon locknut	2	2	2
54	130-14282	Guard	1	1	1
55	376-44000	Flat washer 5/8"	1	1	1
56	346-45000	Nylon locknut 5/8" NC (thin)	1	1	1
57	Std.	Roll pin 5/16" x 2" lg	4	4	4
58	110-15472	Auger drive shaft guard	1	-	-
58	110-25071	Auger drive shaft guard	-	1	-
58	110-15492	Auger drive shaft guard	-	-	1
59	8374	Adjustable clamp fastener (welded)	1	1	1
60	110-01604	Chain guard	1	1	1
61	150-05961	Pin category 2 (top link)	1	1	1
62	150-00332	Idler clevis pin	1	1	1
63	120-02758	Frame P-980TRC	1	-	-
63	120-04914	Frame P-1020TRC	-	1	-
63	120-02778	Frame P-1040TRC	-	-	1
64	300-34280	Bolt 5/16" NC x 1 1/4" lg + nylon locknut	2	2	2
65	9688	Compression spring	1	1	1
66	Std.	Lynch pin 1/4" X 1 3/4"	3	3	3
67	130-85971	Inside guard (bolted)	1	1	1
68	300-36250	Bolt 3/8" NC x 1" + nylon locknut & flat washer	4	4	4
69	130-01373	Inside guard (welded)	1	1	1
70	130-08471	Washer	1	1	1
71	150-01542	Latch pin - drum lock	1	1	1
72	160-03952	Body - drum lock (welded on frame)	1	1	1
73	150-02561	Pin	1	1	1
74	300-40310	Bolt 1/2" NC x 1 1/2" lg + nylon locknut (thin) & flat washer 7/16"	4	4	4
75	110-15201	Hoses support	1	1	1
76	300-38341	Bolt 7/16" NC x 2" lg + jam nut	1	1	1
77	300-40280	Bolt 1/2" NC x 1 1/4" lg + nylon locknut & flat washer	4	4	4
78	130-06571	Guard for ring gear segment	1	1	1
79	UCFD208-24	Bearing 1 1/2" + flange & 2 grease fittings (straight)	3	3	3
80	300-32310	Bolt 1/4" NC x 1 1/2" lg + nylon locknut	2	2	2
81	140-10761	Back plate	3	3	3
82	130-08441	Stop block for drum lock (welded on drum)	1	1	1
83	FD208	Flange F208 for 2 grease fitting	3	3	3
84	UC208-24	Bearing 1 1/2" UC208-24	3	3	3
85	300-40325	Bolt 1/2" NC x 1 3/4" lg + nylon locknut & flat washer 7/16"	8	8	8
86	9471	Sprocket 100A24 T 1 1/2" ø	1	1	1
87	110-02702	Lower auger P-980 (TRC)	1	-	-
87	110-25032	Lower auger P-1020 (TRC)	-	1	-
87	110-02712	Lower auger P-1040 (TRC)	-	-	1
88	VS2-980	Upper auger P-980 (TRC) and components (see p. 47)	opt.	-	-
88	VS2-1020	Upper auger P-1020 (TRC) and components (see p. 47)	- opt.	-	-

SNOWBLOWERS P-980TRC P-1020TRC P-1040TRC (cont'd)

REF.	PART #	DESCRIPTION	QTY		
			P-980TRC	P-1020TRC	P-1040TRC
88	VS2-1040	Upper auger P-1040 (TRC) and components (see p. 47)	-	-	opt.
89	110-12541	Hinged P.T.O. shroud	1	1	1
90	Std.	Grease fitting 1/4"-28 90 deg.	2	2	2
91	300-38310	Bolt 7/16" NC x 1 1/2" + nylon locknut & flat washer	4	4	4
92	300-38280	Bolt 7/16" NC x 1 1/4" lg + nylon locknut	4	4	4
93	130-05911	Deflector	1	1	1
94	302-46550	Bolt 3/4" NF x 5 1/2" lg + nylon locknut	2	2	2
95	140-03561	3-point hitch reinforcement	1	1	1
96	110-18441	Orbit motor support + 4 nut 7/16" NC	1	1	1
97	160-06891	Bushing 1 3/4" i.d. x 1 15/16" o.d. x 1 1/4" lg	1	1	1
98	RSP-1/16x10 ORB	Kit of two unidirectional restrictors	opt.	opt.	opt.

SEMI-INDUSTRIAL CHUTE PSIG-92104

170-03455

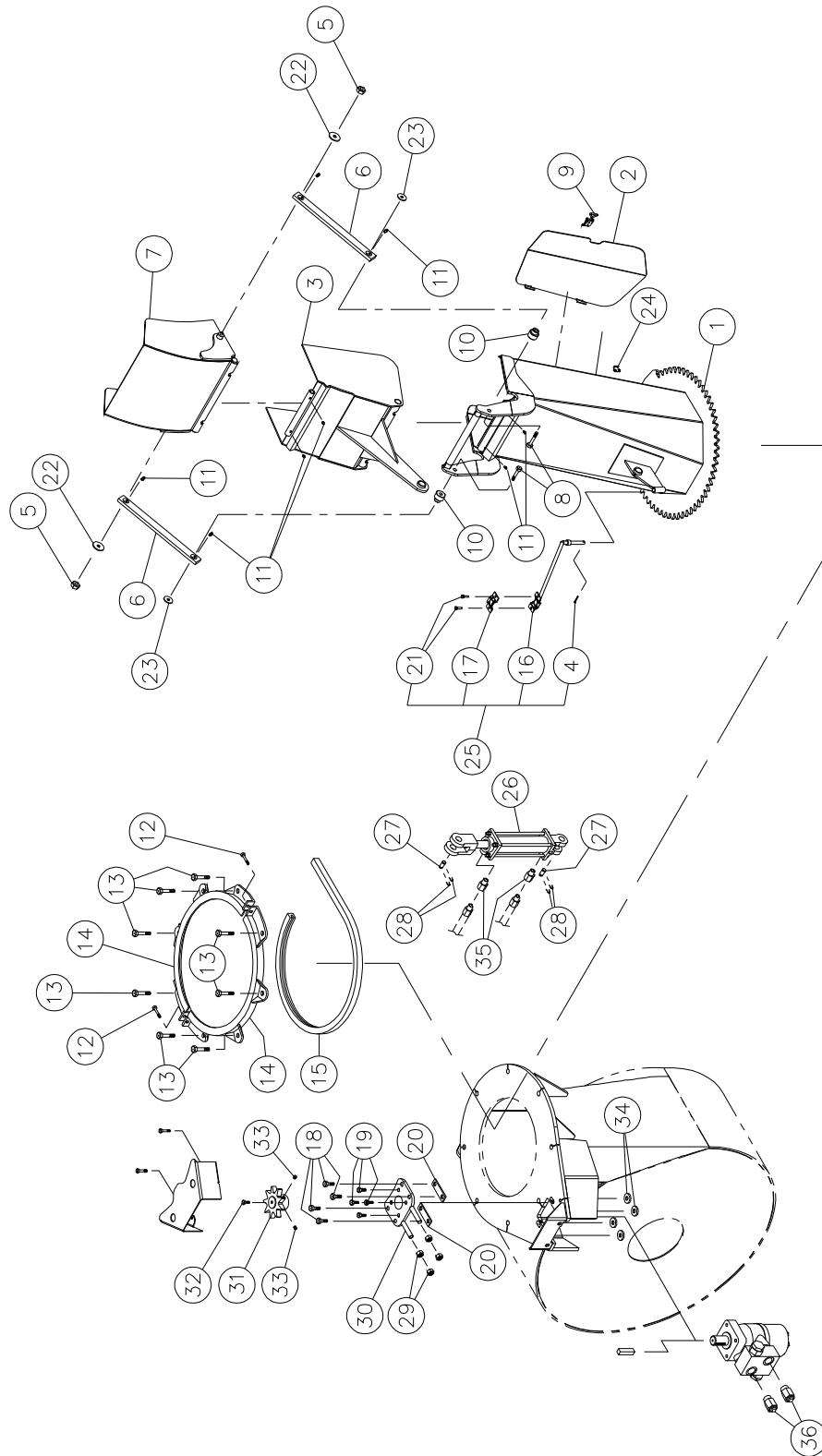

SEMI-INDUSTRIAL CHUTE PSIG-92104

REF.	PART #	DESCRIPTION	QTY
1	110-22555	Chute base	1
2	110-22934	Access panel.....	1
3	110-22232	Lower chute deflector	1
4	Std.	Goupille fendue 1/8" x 1" lg.....	1
5	346-36000	Nylon locknut 3/8" NC	2
6	140-13931	Connecting rod	2
7	110-22242	Upper chute deflector	1
8	300-40400	Bolt 1/2" NC x 3" lg + nylon locknut + flat washer	2
9	8376	Adjustable clamp fastener (welded)	1
10	150-05311	Spacer for connecting rod	2
11	Std.	Grease fitting 1/4" - 28 droit	8
12	300-34340	Bolt 5/16" NC x 2" lg + nylon locknut	2
13	300-40310	Bolt 1/2" NC x 1 1/2" lg + nylon locknut & flat washer	8
14	110-00832	Retaining bracket	2
15	9359	U-shaped UHMW +/- 16 1/2" d.i.	1
16	110-01112	Hoses support rod	1
17	140-13071	Hoses support plate	1
18	300-38250	Bolt 7/16" NC x 1 3/4" lg + nylon locknut & flat washer	4
19	300-36250	Bolt 3/8" NC x 1" lg + lock washer	4
20	140-09571	Spacer 1/8" x 1" x 3 1/4" lg	2
21	300-32250	Bolt 1/4" NC x 1" lg + nylon locknut	2
22	378-36500	Upper flat washer for connecting rod	2
23	376-40000	Lower flat washer for connecting rod	2
24	8377	Hook for clamp fastener (welded)	1
25	TSB-74104	Hoses support for deflector cylinder	opt.
26	25TR08	Cylinder	opt.
27	6004	Clevis pin 1" x 3 1/8"(4).....	opt.
28	Std.	Hairpin cotter 7/8" (4)	opt.
29	346-38000	Nut 7/16" NC	4
30	110-20811	"Orbit" motor support	1
31	110-44331	Sprocket 9 teeth	1
32	300-32220	Bolt 1/4" NC x 3/4" lg + lock washer	1
33	323-36160	Hexagonal socket set screw 3/8" NC x 3/8" lg + lock washer	2
34	150-12741	Flat washer 7/16" heavy-duty	4
35	RSP-1/16x08 NPT	Kit of two unidirectional restrictors 1/2" NPT	opt.
35	RSP-1/16x08 NPT	Kit of two unidirectional restrictors 3/8" NPT	opt.
36	RSP-1/16x10 ORB	Kit of two unidirectional restrictors 10 ORB	opt.

INDUSTRIAL CHUTE PCG-92104

170-03485

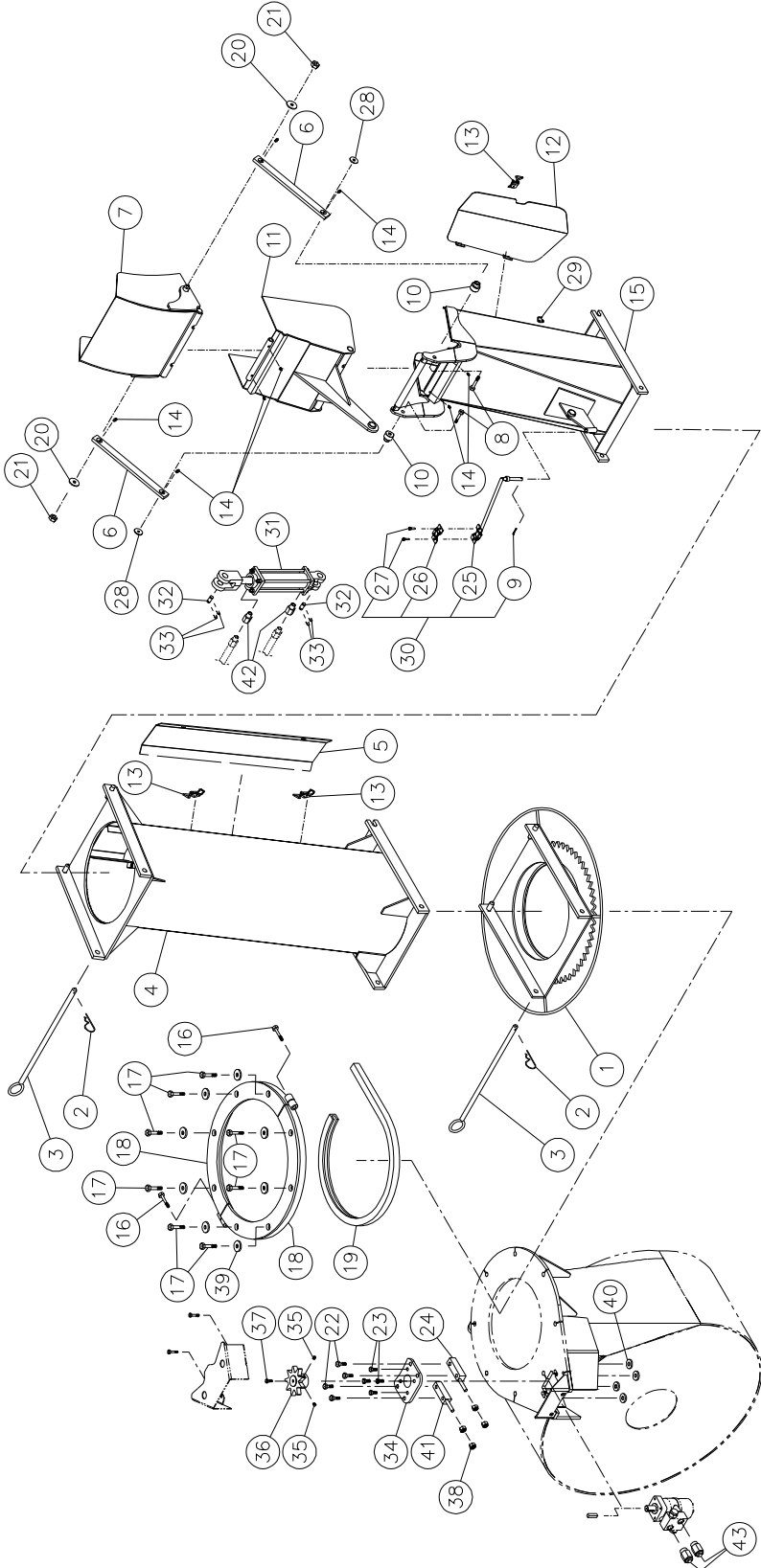

INDUSTRIAL CHUTE PCG-92104

REF.	PART #	DESCRIPTION	QTY
1	110-00681	Chute adaptor with quick attach	1
2	Std.	Hitch pin clip 5/32"	2
3	9414	Pin for quick attach (adaptor & extension)	2
4	PR-92104P-2	Extension 24"	opt.
4	PR-92104P	Extension 48"	opt.
5	110-22942	Access panel for extension 24" # PR-92104P-2	opt.
5	110-22952	Access panel for extension 48" # PR-92104P	opt.
6	140-13931	Connecting rod	2
7	110-22242	Upper deflector	1
8	300-40370	Bolt 1/2" NC x 2 1/2" lg + nylon locknut (thin)	2
9	Std.	Cotter pin 1/8" x 1" lg	1
10	150-05311	Spacer for connecting rod	2
11	110-22232	Lower deflector	1
12	110-22934	Access door	1
13	8376	Adjustable clamp fastener (welded)	1
14	Std.	Grease fitting 1/4" - 28 straight	8
15	110-22755	Chute base	1
16	300-38400	Bolt 7/16" NC x 3" lg + nylon locknut	2
17	300-40415	Bolt 1/2" NC x 3 1/4" lg + nylon locknut	8
18	110-12351	Retaining bracket	2
19	190-03381	U-shaped UHMW +/- 16" i.d.	1
20	378-36500	Upper flat washer for connecting rod	2
21	346-36000	Nylon locknut 3/8" NC	2
22	300-38385	Bolt 7/16" NC x 2 3/4" lg + nylon locknut	4
23	300-36250	Bolt 3/8" NC x 1" lg + lock washer	4
24	110-38321	Right spacer	1
25	110-01112	Hoses support rod	1
26	140-13071	Hoses support plate	1
27	300-32250	Bolt 1/4" NC x 1" lg + nylon locknut	2
28	378-37500	Lower flat washer for connecting rod	2
29	8377	Hook for clamp fastener (welded)	1
30	TSB-74104	Hoses support for deflector cylinder	opt.
31	25TR08	Cylinder	opt.
32	6004	Clevis pin 1" x 3 1/8"(4)	opt.
33	Std.	Hairpin cotter 7/8" (4)	opt.
34	130-08152	"Orbit" motor support	1
35	323-36160	Hexagonal socket set screw 3/8" NC x 3/8" lg	2
36	110-44331	Sprocket 9 teeth	1
37	300-32220	Bolt 1/4" NC x 3/4" lg + lock washer	1
38	346-38000	Nut 7/16" NC	4
39	150-12731	Flat washer 1/2" heavy-duty	16
40	150-12741	Flat washer 3/8" heavy-duty	4
41	110-38322	Left spacer	1
42	RSP-1/16x08 NPT	Kit of two unidirectional restrictors 1/2" NPT	opt.
42	RSP-1/16x08 NPT	Kit of two unidirectional restrictors 3/8" NPT	opt.
43	RSP-1/16x10 ORB	Kit of two unidirectional restrictors 10 ORB	opt.

HYDRAULIC TELESCOPIC CHUTE PCT-92104

170-04071R4

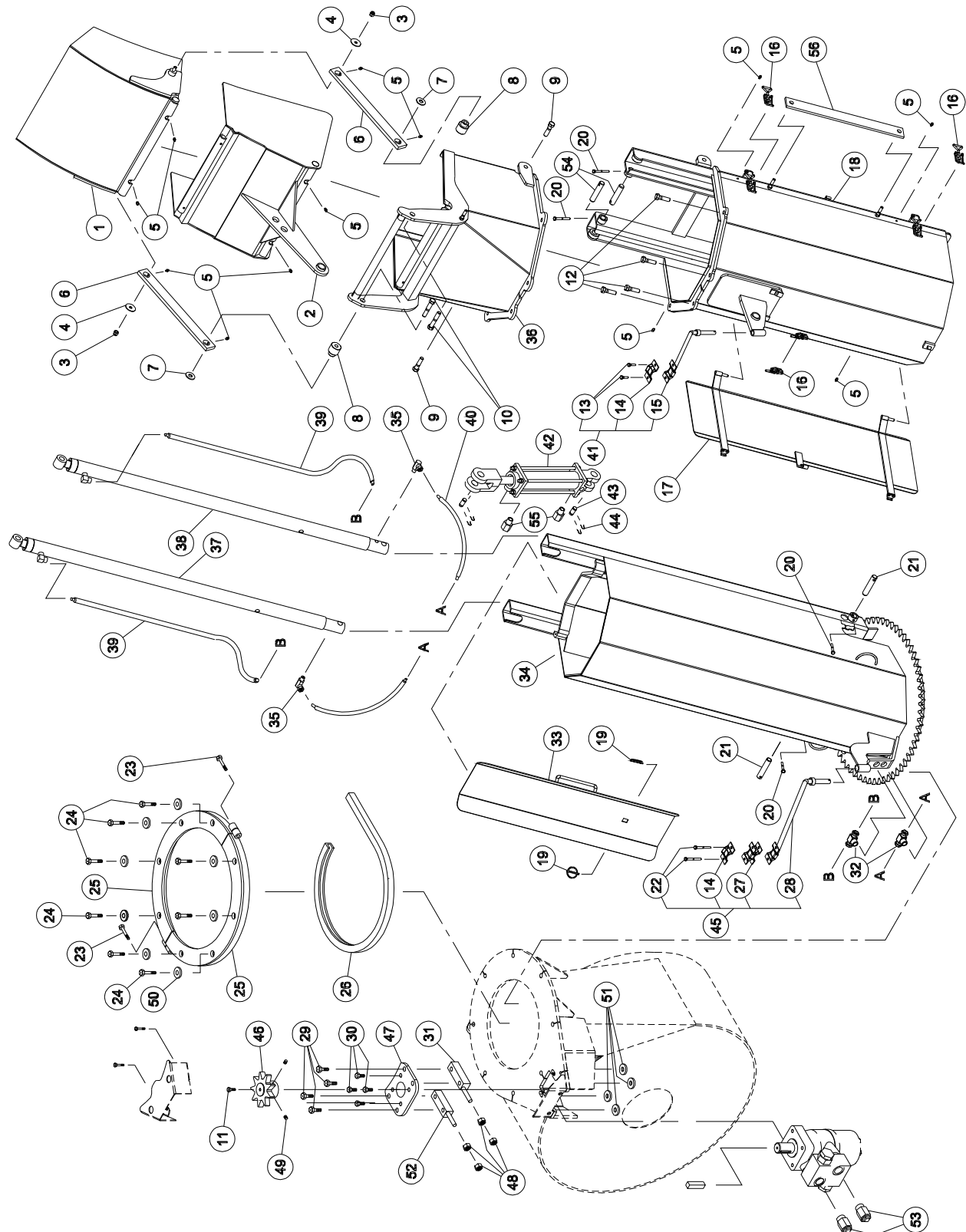

HYDRAULIC TELESCOPIC CHUTE PCT-92104

REF.	PART #	DESCRIPTION	QTY
1	110-29112	Upper chute deflector	1
2	110-29121	Lower chute deflector	1
3	346-36000	Nylon locknut 3/8"	2
4	378-36500	Flat washer 3/8" i.d. x 1 1/2" o.d.	2
5	Std.	Grease fitting 1/4"-28 straight	12
6	140-13931	Connecting rod	2
7	378-37500	Washer 1/2" i.d. x 1 3/8" o.d.	2
8	150-05311	Spacer for connecting rod	2
9	300-40340	Bolt 1/2" NC x 2" lg + nylon locknut	2
10	300-40380	Bolt 1/2" NC x 2 3/4" lg + nylon locknut	2
11	300-32220	Bolt 1/4" NC x 3/4" lg + lock washer	1
12	300-40325	Bolt 1/2" NC x 1 3/4" lg + 2 washers + nylon locknut	4
13	300-32250	Bolt 1/4" NC x 1" lg + nylon locknut	2
14	140-13071	Hoses mounting plate	2
15	110-01122	Mounting support plate for upper extension	1
16	8376	Clamp fastener	3
17	110-29391	Access door for upper extension	1
18	110-26642	Upper extension	1
19	Std.	Lynch pin 3/16" x 1 1/4"	2
20	300-32325	Bolt 1/4" NC x 1 3/4" lg + nylon locknut	4
21	150-12701	Pin	2
22	300-32370	Bolt 1/4" NC x 2 1/2" lg + nylon locknut	2
23	300-38400	Bolt 7/16" NC x 3" lg + nylon locknut	2
24	300-40415	Bolt 1/2" NC x 3 1/4" lg + nylon locknut	8
25	110-12351	Retaining bracket	2
26	190-03381	U-shaped UHMW + - 16" approx. inside diameter	1
27	110-20611	Hoses mounting plate	1
28	110-04982	Mounting support plate for lower extension	1
29	300-38370	Bolt 7/16" NC x 2 1/2" lg + nylon locknut & flat washer	4
30	300-36250	Bolt 3/8" NC x 1" lg + lock washer	4
31	110-38321	Right spacer	1
32	9456-06-06	«T» female 3/8" NPT swivel , female 3/8" NPT	2
33	110-26671	Access door for lower extension	1
34	110-26651	Lower extension	1
35	9406-04-04	Elbow 90 degrees 1/4" NPT swivel	2
36	110-29102	Hexagonal extension	1
37	15 PC 32G	Cylinder 1 1/2" x 32" stroke	1
38	15 PC 32D	Cylinder 1 1/2" x 32" stroke	1
39	190-08231	Hose 1/4" SAE 100R2AT - 500 PSI x 69 1/2" lg	2
40	190-08241	Hose 1/4" SAE 100R2AT - 500 PSI x 26 1/2" lg	2
41	TSB-4864	Hoses support for deflector cylinder	opt.
42	25TR08	Cylinder	opt.
43	6004	Clevis pin 1" x 3 1/8"(4)	opt.
44	Std.	Hairpin cotter 7/8" (4)	opt.
45	TSB-74104-IND	Hoses support on chute base	opt.
46	110-44331	Sprocket 9 teeth	1
47	130-08152	"Orbit" motor support	1
48	336-38000	Nut 7/16" NC	4
49	323-36160	Hexagonal socket set screw 3/8" NC x 3/8" lg	2
50	150-12731	Flat washer 1/2" heavy-duty	16
51	150-12741	Flat washer 7/16" heavy-duty	4
52	110-38322	Left spacer	1
53	RSP-1/16x10 ORB	Kit of two unidirectional restrictors 10 ORB	1
54	150-13181	Pin	2
55	RSP-1/16x06 NPT	Kit of two unidirectional restrictors 3/8" NPT	opt.
55	RSP-1/16x08 NPT	Kit of two unidirectional restrictors 1/2" NPT	opt.
56	140-25231	Support for transport in folded position	1

HYDRAULIC TELESCOPIC CHUTE PCTC-INDR

170-05401

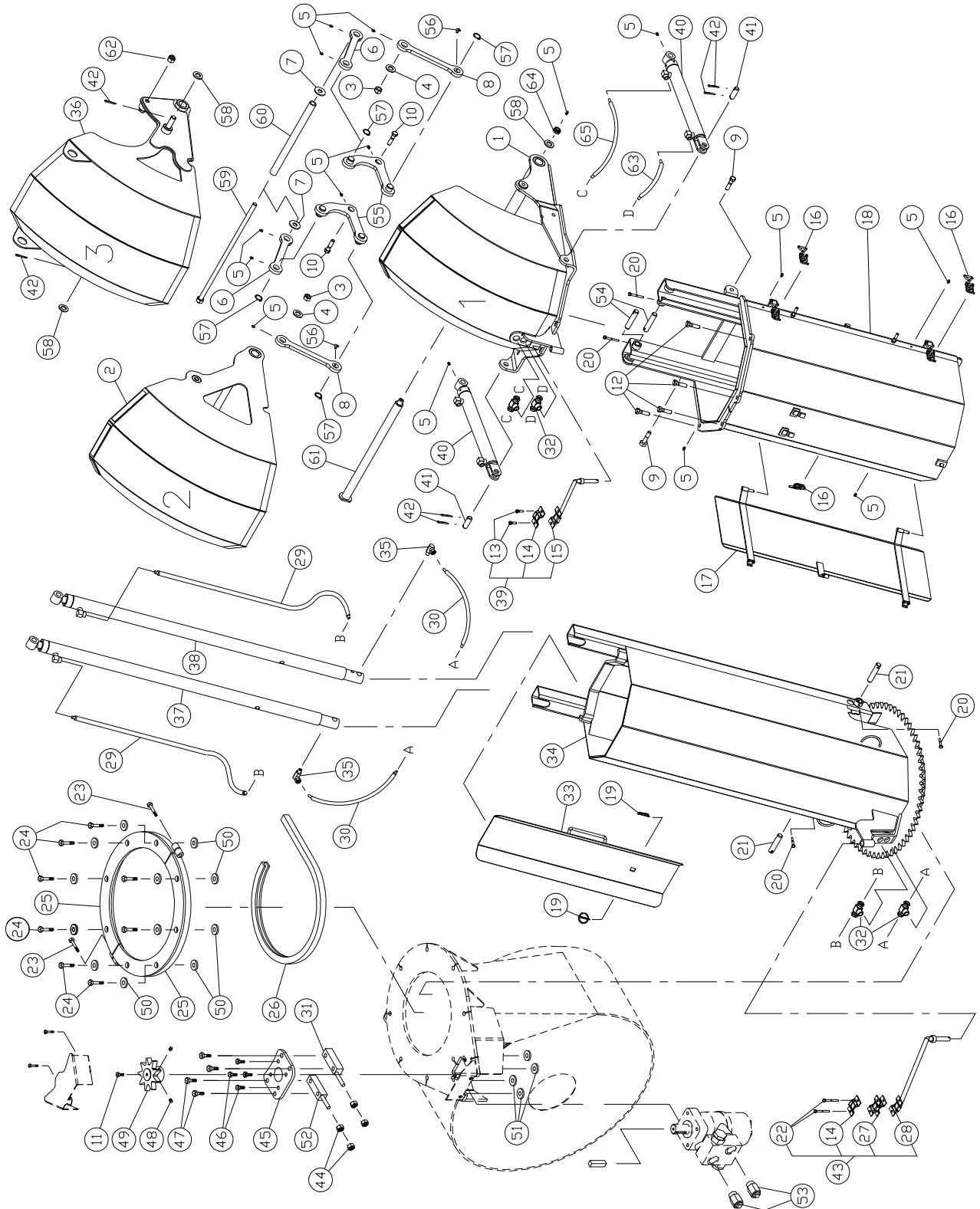

HYDRAULIC TELESCOPIC CHUTE PCTC-INDR (cont'd)

REF.	PART #	DESCRIPTION	QTY
1	110-43233	Stationary deflector	1
2	110-43203	Intermediate deflector	1
3	346-36000	Nylon locknut 3/8"	2
4	378-36500	Flat washer 3/8" i.d. x 1 1/2" o.d.	2
5	Std.	Grease fitting 1/4"-28 straight	15
6	130-84931	Lever for terminal deflector	2
7	376-43000	Flat washer 5/8" i.d. x 1 1/2" o.d.	2
8	130-84942	Lever for intermediate deflector	2
9	300-40340	Bolt 1/2" NC x 2" lg + nylon locknut	2
10	300-40380	Bolt 1/2" NC x 2" lg + flat washer + nylon locknut	2
11	300-32220	Bolt 1/4" NC x 3/4" lg + lockwasher	1
12	300-40325	Bolt 1/2" NC x 1 3/4" lg + nylon locknut	4
13	300-32250	Bolt 1/4" NC x 1" lg + nylon locknut	2
14	140-13071	Hoses mounting plate	2
15	110-01122	Mounting support plate for upper extension	1
16	8376	Adjustable clamp fastener	3
17	110-29391	Access panel for upper extension	1
18	110-39152	Upper extension	1
19	Std.	Lynch pin 3/16" x 1 1/4"	2
20	300-32325	Bolt 1/4" NC x 1 3/4" lg + nylon locknut	4
21	150-12701	Clevis pin	2
22	300-32370	Bolt 1/4" NC x 2 1/2" lg + nylon locknut	2
23	300-38400	Bolt 7/16" NC x 3" lg + nylon locknut	2
24	300-40415	Bolt 1/2" NC x 3 1/4" lg + nylon locknut	8
25	110-12351	Retaining bracket	2
26	190-03381	U-shaped UHMW + - 16" i.d.	1
27	110-20611	Hoses mounting plate	1
28	110-04982	Mounting support plate for lower extension	1
29	190-08231	Hose 1/4" x 67 1/4" lg + 1 fitting 4U104 + 1 4U106	2
30	190-08241	Hose 1/4" x 24 1/4" lg + 1 fitting 4U104 + 1 4U106	2
31	110-38321	Spacer	1
32	9456-06-06	«T» female 3/8" NPT swivel , female 3/8" NPT	4
33	110-26671	Access door for lower extension	1
34	110-39001	Lower extension	1
35	9406-04-04	Elbow 90 degress 1/4" NPT swivel	2
36	110-43193	Terminal deflector	1
37	15 PC 32G	Cylinder 1 1/2" x 32" stroke	1
38	15 PC 32D	Cylinder 1 1/2" x 32" stroke	1
39	TSB-4864	Hoses support for deflector cylinder	1
40	15L12	Cylinder 1 1/2" x 12" stroke	2
41	150-14101	Clevis pin 3/4" x 2 1/8" lg	2
42	Std.	Cotter pin 3/16" x 1 1/4"	6
43	TSB-74104-IND	Hoses support on chute base	1
44	336-38000	Nut 7/16" NC	4
45	130-08152	"Orbit" motor support	1
46	300-36250	Bolt 3/8" NC x 1" lg + lock washer	4
47	300-38385	Bolt 7/16" NC x 2 3/4" lg + nylon locknut	4
48	323-36160	Hexagonal socket set screw 3/8" NC x 3/8" lg	2
49	110-44331	Sprocket 9 tooth	1
50	150-12731	Flat washer 1/2" heavy duty	16
51	150-12741	Flat washer 7/16" heavy duty	4
52	110-38322	Spacer	1
53	RSP-1/16x10 ORB	Kit of two unidirectional restrictors	1
54	150-13181	Clevis pin	2
55	110-45643	Central lever pivot	2
56	std.	Grease fitting elbow 90 degrees 1/4-28	2

HYDRAULIC TELESCOPIC CHUTE PCTC-INDR (cont'd)

REF.	PART #	DESCRIPTION	QTY
57	Std.	Retaining ring - external 1"	4
58	376-46310	Flat washer 3/4" d.i. x 1 1/2" d.e.	3
59	110-45661	Threaded rod 5/8"-11 NC x 20 1/4" lg + nut 5/8" (welded).....	1
60	150-14921	Spacer 14 29/32" lg	1
61	110-43221	Pin for main pivot.....	1
62	346-44000	Nylon nut 5/8" NC	1
63	190-13231	Hose 1/4" x 15 1/2" lg + 1 fitting 4U104 + 1 fitting 4U106	2
64	346-47000	Nylon nut thin 3/4" NC	1
65	190-13241	Hose 1/4" x 28 1/2" lg + 1 fitting 4U104 + 1 fitting 4U106	2

OPTIONS

170-02117

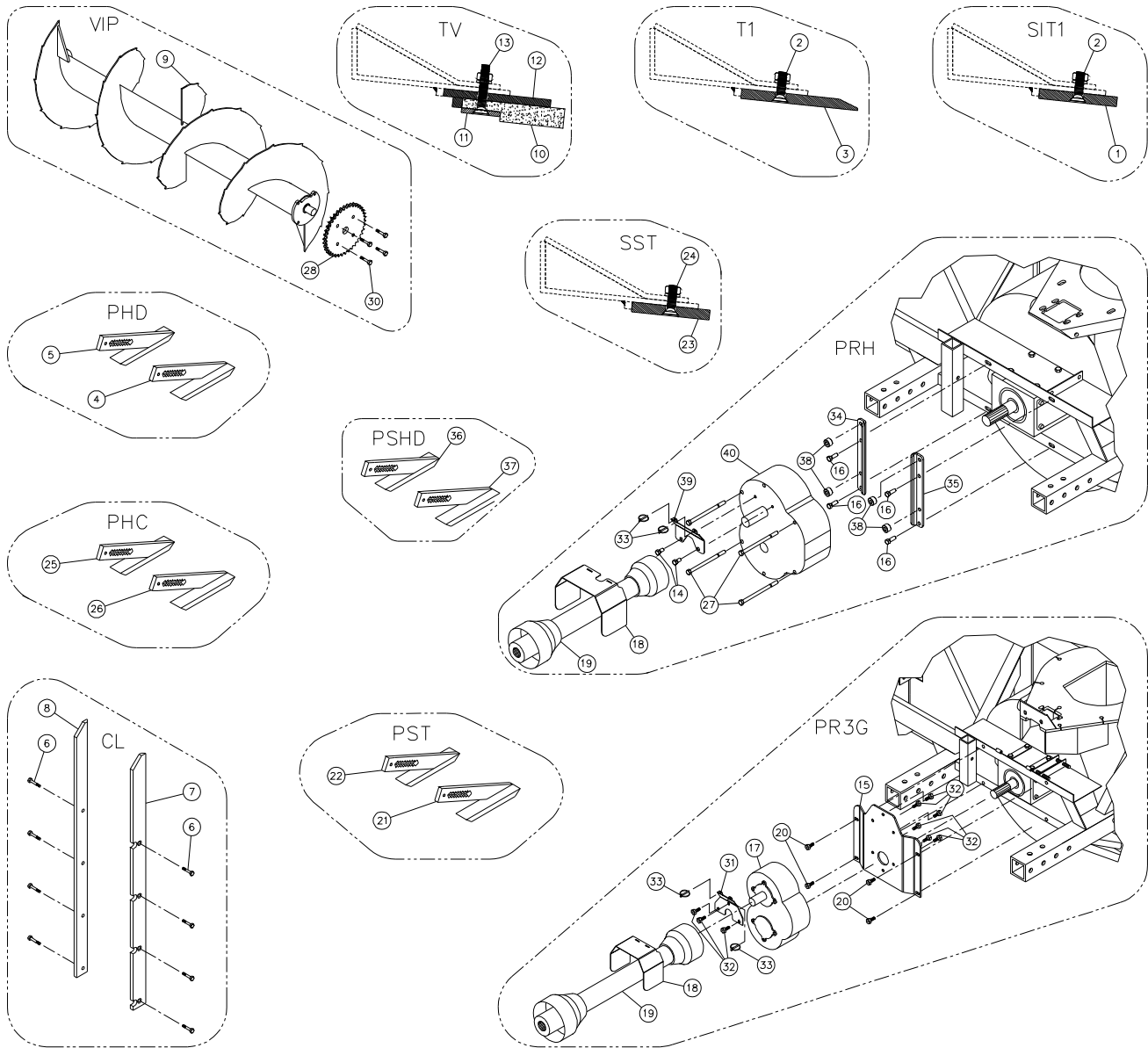

REF.	PART #	DESCRIPTION	P-992	P-992 TRC	P-980	P-980 TRC	P-1020	P-1020 TRC	P-1040	P-1040 TRC
1	140-04081	Scraper blade (hardened steel, not sharpened, reversible) 1/2" x 4" x 84 1/2"	1	1	-	-	-	-	-	-
1	140-04091	Scraper blade (hardened steel, not sharpened, reversible) 1/2" x 4" x 90 1/2"	-	-	1	1	-	-	-	-
1	140-21631	Scraper blade (hardened steel, not sharpened, reversible) 1/2" x 4" x 95"	-	-	-	-	1	1	-	-
1	140-04101	Scraper blade (hardened steel, not sharpened, reversible) 1/2" x 4" x 97"	-	-	-	-	-	-	1	1
2	319-38310	Plow bolt 7/16" NC x 1 1/2" lg + nut & lock washer	9	9	9	9	10	10	10	10
3	140-04141	Scraper blade (hardened steel, sharpened, not reversible) 1/2" x 6" x 84 1/2"	1	1	-	-	-	-	-	-
3	140-04151	Scraper blade (hardened steel, sharpened, not reversible) 1/2" x 6" x 90 1/2"	-	-	1	1	-	-	-	-
3	140-21641	Scraper blade (hardened steel, sharpened, not reversible) 1/2" x 6" x 95"	-	-	-	-	1	1	-	-
3	140-04161	Scraper blade (hardened steel, sharpened, not reversible) 1/2" x 6" x 97"	-	-	-	-	-	-	1	1

OPTIONS

REF.	PART #	DESCRIPTION	P-992	P-992 TRC	P-980	P-980 TRC	P-1020	P-1020 TRC	P-1040	P-1040 TRC
4	110-05511	Carbon steel skid shoe (right side)	1	1	1	1	1	1	1	1
5	110-04811	Carbon steel skid shoe (right side)	1	1	1	1	1	1	1	1
6	319-38310	Plow bolt 7/16" NC x 1 1/2" lg + nut & lock washer	8	8	8	8	8	8	8	8
7	130-08301	Lateral blade (right side)	1	1	-	-	-	-	-	-
7	130-08311	Lateral blade (right side)	-	-	1	1	1	1	1	1
8	130-08302	Lateral blade (left side)	1	1	-	-	-	-	-	-
8	130-19281	Lateral blade (left side)	-	-	1	1	1	1	1	1
9	110-45861	Full flight spiked auger 23" ø x 89 5/8" lg overall	1	1	-	-	-	-	-	-
9	110-46111	Full flight spiked auger 26" ø x 95 11/16" lg overall	-	-	1	1	-	-	-	-
9	110-25162	Full flight spiked auger 26" ø x 99 11/16" lg overall	-	-	-	-	1	1	-	-
9	110-46121	Full flight spiked auger 26" ø x 101 11/16" lg overall	-	-	-	-	-	-	1	1
10	190-01331	Scraper blade, TIVAR not reversible 1" x 5 1/4" x 84 1/2"	1	1	-	-	-	-	-	-
10	190-01321	Scraper blade, TIVAR not reversible 1" x 5 1/4" x 90 1/2"	-	-	1	1	-	-	-	-
10	190-10261	Couteau en TIVAR non réversible 1" x 5 1/4" x 95"	-	-	-	-	1	1	-	-
10	190-01341	Scraper blade, TIVAR not reversible 1" x 5 1/4" x 97"	-	-	-	-	-	-	1	1
11	140-03991	TIVAR blade bolting plate 1/4" x 2" x 84 1/2"	1	1	-	-	-	-	-	-
11	140-03981	TIVAR blade bolting plate 1/4" x 2" x 90 1/2"	-	-	1	1	-	-	-	-
11	140-21651	TIVAR blade bolting plate 1/4" x 2" x 95"	-	-	-	-	1	1	-	-
11	140-04001	TIVAR blade bolting plate 1/4" x 2" x 97"	-	-	-	-	-	-	1	1
12	110-10391	TIVAR blade holder 3/8" x 5 1/2" x 84 1/2"	1	1	-	-	-	-	-	-
12	110-10381	TIVAR blade holder 3/8" x 5 1/2" x 90 1/2"	-	-	1	1	-	-	-	-
12	110-37141	TIVAR blade holder 3/8" x 5 1/2" x 95"	-	-	-	-	1	1	-	-
12	110-10401	TIVAR blade holder 3/8" x 5 1/2" x 97"	-	-	-	-	-	-	1	1
13	319-38355	Plow bolt 7/16" NC x 2 1/4" lg + nut & locknut	9	9	9	9	10	10	10	10
14	300-40250	Bolt 1/2" NC x 1" lg + nut & lock washer	2	2	2	2	2	2	2	2
15	130-76201	Mounting plate for speed reducer	1	1	1	1	1	1	1	1
16	300-40310	Bolt 1/2" NC x 1 1/2" lg + nylon locknut & flat washer (x)	4	4	4	4	4	4	4	4
17	9721	Speed reducer 1000@540 - gears PR3G-200-2	1	1	1	1	1	1	1	1
18	130-67491	P.T.O. shroud for speed reducer	1	1	1	1	1	1	1	1
19	9569	P.T.O. T80, QD 1 3/8" -21, SBI 1 3/4" -20	1	1	1	1	1	1	1	1
19	9569-1	P.T.O. T80, QD 1 3/4" -20, SBI 1 3/4" -20	1	1	1	1	1	1	1	1
19	9475-1	P.T.O. T90, QD 1 3/8" -21, SBI 1 3/4" -20	1	1	1	1	1	1	1	1
19	9475-2	P.T.O. T90, QD 1 3/4" -20, SBI 1 3/4" -20	1	1	1	1	1	1	1	1
20	300-40310	Boltn 1/2 NC x 1 1/2" lg + flat washer & nylon locknut	4	4	4	4	4	4	4	4
21	110-24831	Stainless steel skid shoe (right side)	1	1	1	1	1	1	1	1
22	110-24832	Stainless steel skid shoe (left side)	1	1	1	1	1	1	1	1
23	140-15041	Scraper blade (stainless steel, not sharpened, reversible) 1/2" x 4" x 84 1/2"	1	1	-	-	-	-	-	-
23	140-15051	Scraper blade (stainless steel, not sharpened, reversible) 1/2" x 4" x 90 1/2"	-	-	1	1	-	-	-	-
23	140-21681	Scraper blade (stainless steel, not sharpened, reversible) 1/2" x 4" x 95"	-	-	-	-	1	1	-	-
23	140-15091	Scraper blade (stainless steel, not sharpened, reversible) 1/2" x 4" x 97"	-	-	-	-	-	-	1	1
24	319-38310	Plow bolt 7/16" NC x 1 1/2" lg + nut & lock washer	9	9	9	9	10	10	10	10
24	333-40340	Hexagonal socket set screw 1/2" NC x 2" lg (inox.) + nut & lock washer	opt.	opt.	opt.	opt.	opt.	opt.	opt.	opt.
25	110-32871	Skid shoe (left side) with carbide sole	1	1	1	1	1	1	1	1
26	110-32872	Skid shoe (right side) with carbide sole	1	1	1	1	1	1	1	1
27	300-40700	Bolt 1/2" NC x 8" lg + nylon locknut	-	-	1	1	1	1	1	1
28	9281	Sprocket 80A30 T 1 1/2"	1	1	-	-	-	-	-	-
28	190-10351	Sprocket 100A24 T 1 1/2"	-	-	1	1	1	1	1	1
29	130-67491	P.T.O. shroud for speed reducer	1	1	1	1	1	1	1	1
30	300-38310	Bolt 7/16" NC x 1 1/2" lg + two way locknut	4	4	-	-	-	-	-	-

OPTIONS

REF.	PART #	DESCRIPTION	P-992	P-992 TRC	P-980	P-980 TRC	P-1020	P-1020 TRC	P-1040	P-1040 TRC
30	300-38325	Bolt 7/16" NC x 1 3/4" lg + two way locknut	-	-	4	4	4	4	4	4
31	130-76211	Plate for reducer 1000@540 with gears (200 HP)	1	1	1	1	1	1	1	1
32	300-40280	Bolt 1/2" NC x 1 1/4" lg + lock washer	9	9	9	9	9	9	9	9
33	Std.	Lynch pin 1/4" x 1 13/4" lg	2	2	2	2	2	2	2	2
34	130-84911	Mounting plate for speed reducer (left side)	1	1	1	1	1	1	1	1
35	130-84912	Mounting plate for speed reducer (right side)	1	1	1	1	1	1	1	1
36	110-45771	Skid shoe (left side) with Rocktec sole	1	1	1	1	1	1	1	1
37	110-45772	Skid shoe (right side) with Rocktec sole	1	1	1	1	1	1	1	1
38	150-14941	Spacer 1 1/4" dia x 3/4" lg	4	4	4	4	4	4	4	4
39	130-84951	Guard mounting plate	1	1	1	1	1	1	1	1
40	9769	Speed reducer 1000@555 (gears) PRH-30M-2	1	1	1	1	1	1	1	1

UPPER AUGER VS2

170-03455

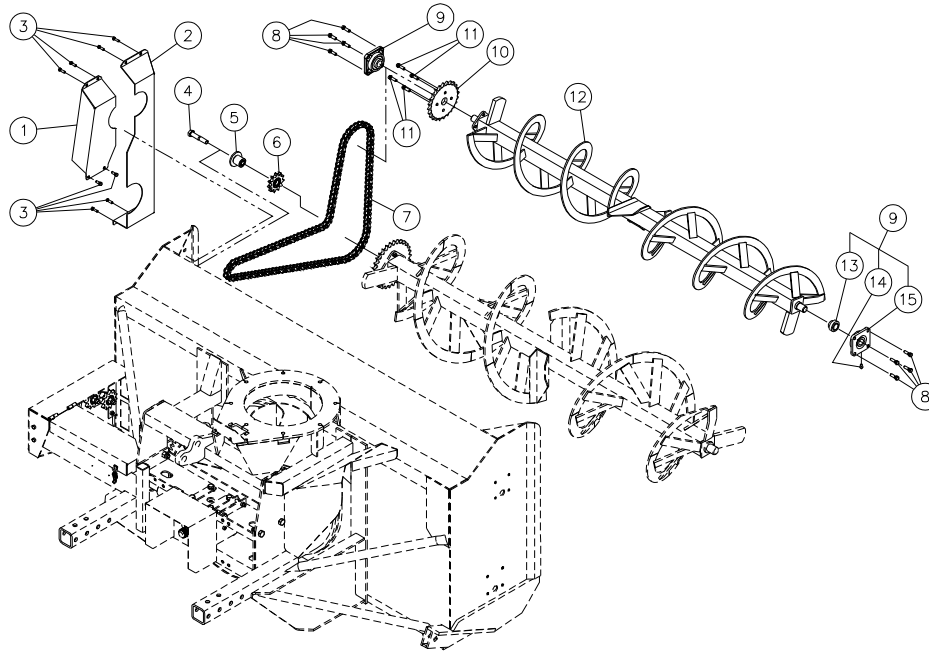

REF.	PART #	DESCRIPTION	QTY			
			VS2-992	VS2-980	VS2-1020	VS2-1040
1	110-46191	Inside guard (bolted)	1	-	-	-
1	110-46201	Inside guard (bolted)	-	1	1	1
2	110-46171	Double inside guard (bolted)	1	-	-	-
2	110-46181	Double inside guard (bolted)	-	1	1	1
3	300-36250	Bolt 3/8" NC x 1" lg. + flat washer + nylon locknut	8	8	8	8
4	300-46460	Bolt 3/4" NC x 4" lg. + flat washer + nylon locknut	1	1	1	1
5	110-43711	Idler	1	1	1	1
6	9287	Idler sprocket #80	1	-	-	-
6	9768	Idler sprocket #100	-	1	1	1
7	110-45911	Chain #80 x 119" lg	1	-	-	-
7	110-46081	Chain #100 x 126 1/4" lg	-	1	1	1
7	26A80	Connecting link no. 80	1	-	-	-
7	26A100	Connecting link no. 100	-	1	1	1
7	59-80	Offset link no.80	1	-	-	-
8	300-38310	Bolt 7/16" NC x 1 1/2" l. + flat washer 3/8" + nylon locknut	8	8	8	8
9	UCFD207-20	Bearing 1 1/4" + flange & 2 grease fittings (straight)	2	2	2	2
10	190-13081	Sprocket 80A24 T1 1/2"	1	-	-	-
10	190-13201	Sprocket 100A18 T1 1/2"	-	1	1	1
11	300-38310	Bolt 7/16" NC x 1 1/2" lg. + two-way locknut	4	-	-	-
11	300-38325	Bolt 7/16" NC x 1 3/4" lg. + two-way locknut	-	4	4	4
12	110-45711	Upper auger P-992	1	-	-	-
12	110-43691	Upper auger P-980	-	1	-	-
12	110-25092	Upper auger P-1020	-	-	1	-
12	110-46071	Upper auger P-1040	-	-	-	1
13	UC-207-20	Bearing 1 1/4"	2	-	-	-
14	Std.	Grease fitting 1/4"-28 straight	4	-	-	-
15	FD207	Flange for 2 grease fitting	2	-	-	-

P.T.O. SHAFT # 9225-EG & 9569 (T80)

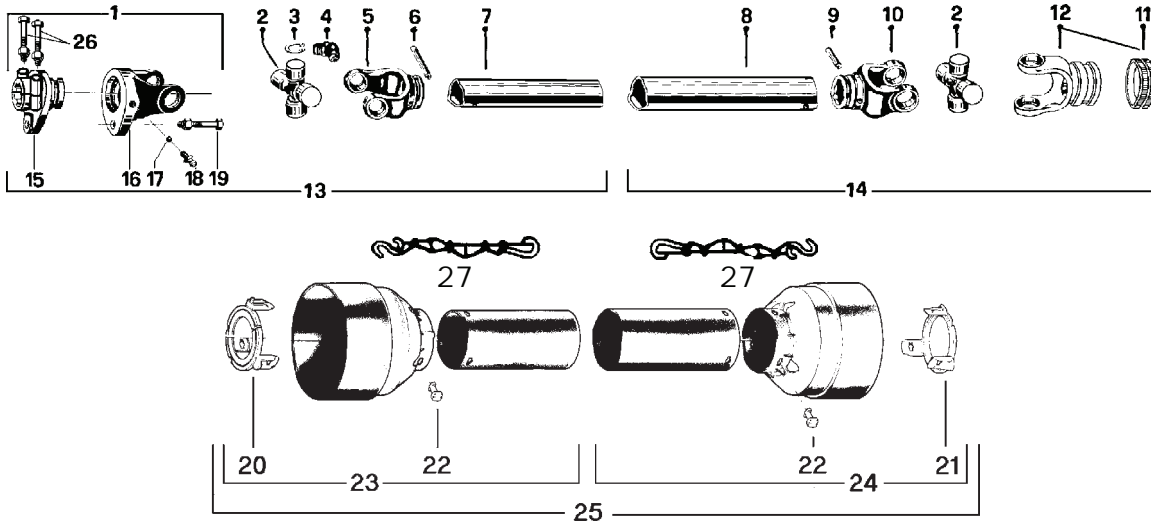

REF.	PART #	DESCRIPTION	QTY
			9225-EG 9569
or [1	9570	Safety shear yoke M10 (2 bolts) 1 3/4" - 20 splines	1
1	9453	Safety shear yoke M12 (2 bolts) 1 3/4" - 20 splines	1
2	9208	U-joint + 4 retaining rings + 1 grease fitting	2
3	9454	Retaining ring	8
4	8110	Grease fitting	2
5	9214	Yoke for inner tube	1
6	8075	Stopper for inner tube	1
7	9212	Inner tube	1
8	9211	Outer tube	1
9	9210-E	Stopper for outer tube	1
10	9209	Yoke for outer tube	1
11	8363	Collar kit	1
11	8364	Collar kit	- opt.
12	9455	Yoke with hole 1 3/8"-6 splines + yoke stopper	1
12	9463	Yoke with hole 1 3/8"-21 splines + yoke stopper	- 1
12	9224	Yoke with hole 1 3/4"-20 splines + yoke stopper	- opt.
13	9456	P.T.O. section, SBI 1 3/4"-20, inner part, with protector	1
14	9457	P.T.O. section, QD 1 3/8"-6, outer part, with protector	1
14	9457-2	P.T.O. section, QD 1 3/8"-21, outer part, with protector	- 1
or [15	9458	Adaptor 1 3/4"-20 splines (2 bolts) (hole 12 mm)	1
15	9571	Adaptor 1 3/4"-20 splines (2 bolts) (hole 10 mm)	- 1
or [16	9204	Yoke and shearplate (hole 12 mm)	1
16	9572	Yoke and shearplate (hole 10 mm)	- 1
17	9205	Ball	17
18	8071	Grease fitting	1
19	9207	Safety shear bolt grade 10.9 M12 x 65 mm	1
or [19	9207-375	Safety shear bolt grade 8.8 M12 x 65 mm (reduced to 10 mm at the point of rupture)	- 1
19	8218	Safety shear bolt grade 8.8 M10 x 60 mm	- 1
20	9459	Bearing ring for inner guard tube	1
21	9460	Bearing ring for outer guard tube	1
22	8109	Stopper	6
23	9221	Inner shield	1
24	9220	Outer shield	1
25	9222	Complete shield	1
26	9662	Bolt M16 x 80 mm + lock nut	2
27	8308	Safety chain	2

10

P.T.O. SHAFT # 9475, 9475-1 & 9475-2 (T90)

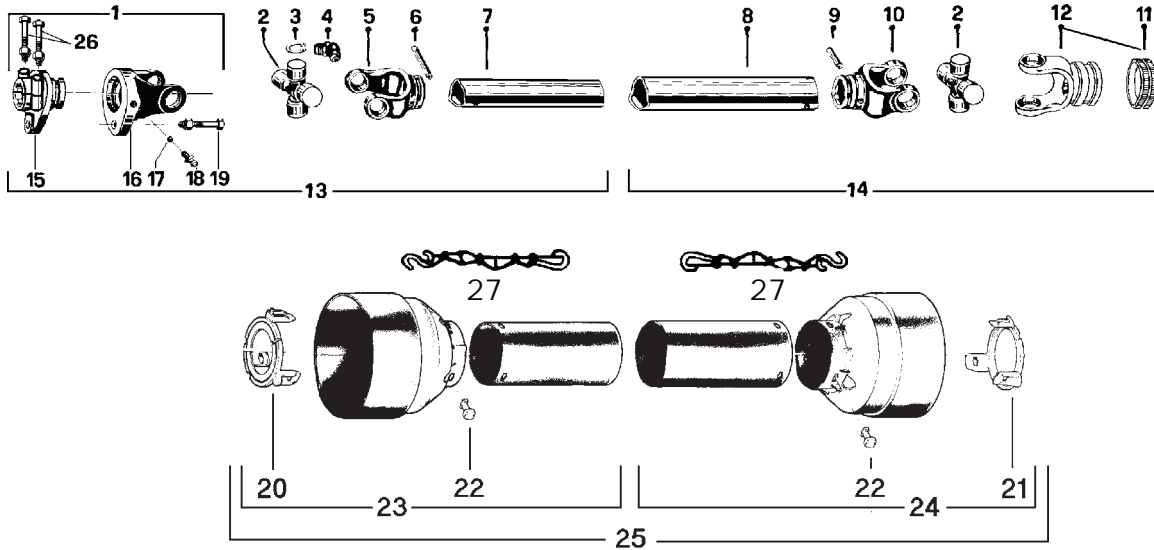

REF.	PART #	DESCRIPTION	QTY		
			9475	9475-1	9475-2
1	9476	Safety shear yoke (2 bolts) 1 3/4" - 20 splines	1	1	1
2	9477	U-joint + 4 retaining rings + 1 grease fitting	2	2	2
3	9478	Retaining ring	8	8	8
4	8110	Grease fitting	2	2	2
5	9479	Yoke for inner tube	1	1	1
6	9210	Stopper for tube	1	1	1
7	9212	Inner tube	1	1	1
8	9211	Outer tube	1	1	1
9	9210	Stopper for tube	1	1	1
10	9480	Yoke for outer tube	1	1	1
11	8363	Collar kit	1	1	-
11	8364	Collar kit	-	-	1
12	9481	Yoke with hole 1 3/8"-6 splines + yoke stopper	1	-	-
12	9482	Yoke with hole 1 3/8"-21 splines + yoke stopper	-	1	-
12	9483	Yoke with hole 1 3/4"-20 splines + yoke stopper	-	-	1
13	9484	P.T.O. section, SBI 1 3/4"-20, inner part, with protector	1	1	1
14	9485	P.T.O. section, QD 1 3/8"-6, outer part, with protector	1	-	-
14	9485-1	P.T.O. section, QD 1 3/8"-21, outer part, with protector	-	1	-
14	9485-2	P.T.O. section, QD 1 3/4"-20, outer part, with protector	-	-	1
15	9486	Adaptor 1 3/4"-20 splines (2 bolts)	1	1	1
16	9487	Yoke and shearplate	1	1	1
17	9205	Ball	24	24	24
18	8071	Grease fitting	1	1	1
19	9207	Safety shear bolt grade 10.9 M12 x 65 mm	1	-	-
19	9207-375	Safety shear bolt grade 8.8 M12 x 65 mm (reduced to 10 mm at the point of rupture)	-	1	1
20	9459	Bearing ring for inner guard tube	1	1	1
21	9460	Bearing ring for outer guard tube	1	1	1
22	8109	Stopper	6	6	6
23	9221	Inner shield	1	1	1
24	9220	Outer shield	1	1	1
25	9222	Complete shield	1	1	1
26	9662	Bolt M16 x 80 mm + lock nut	2	2	2
27	8308	Safety chain	2	2	2

GEAR BOX # 9307 (T279)

170-05031.tif

Oil volume required: 1.64 liters
Use SAE 80W90 oil or equivalent.

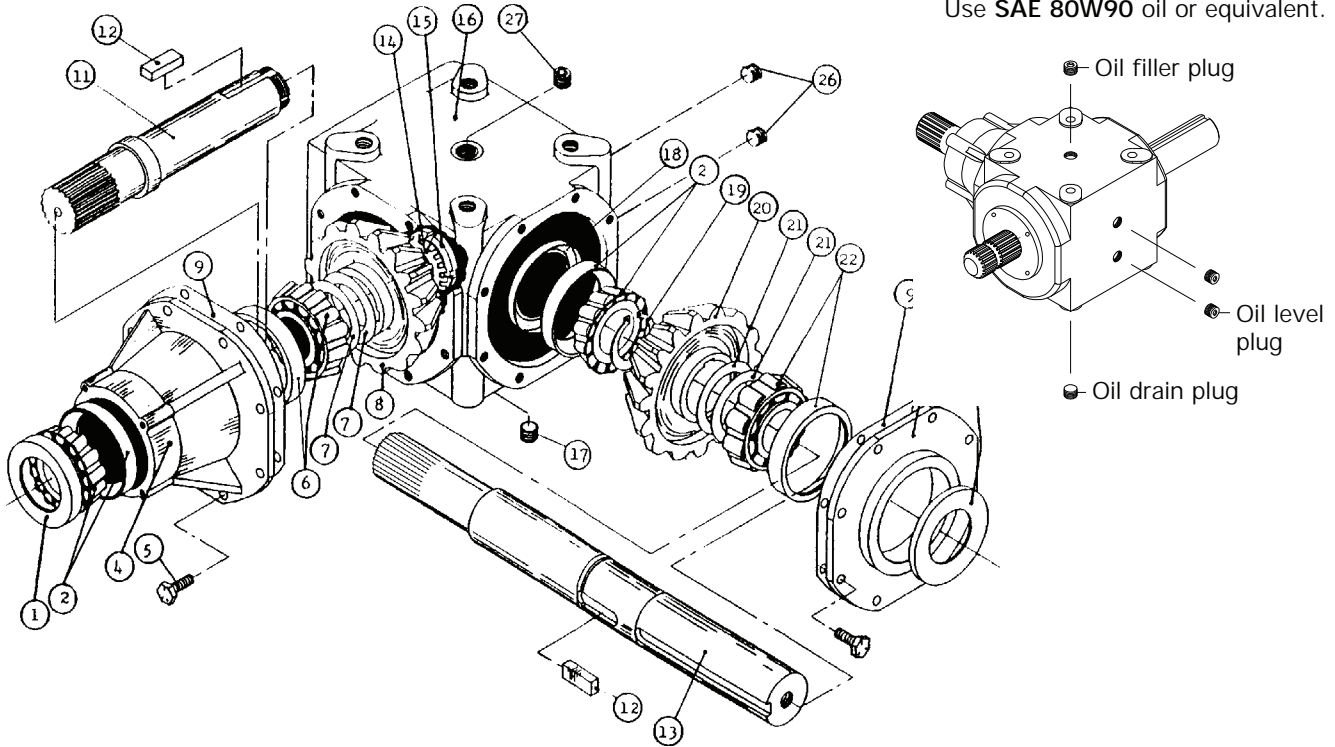

REF.	PART #	DESCRIPTION	QTY
1	6314	Oil seal 52 x 85 x 10	1
2	30209-A	Bearing: cone & cup	2
4	6318	Extension	1
5	6319	Bolt M10 x 22	16
6	32209-A	Bearing: cone & cup	1
7	6321	Shim	2
8	6322	Gear Z21	1
9	- - -	Use silicone caulking	-
11	6325	Side shaft Z20 (1¾" - 20 splines)	1
12	6326	Key B14 x 9 x 40	2
13	9345	Impeller shaft (2" & 1¾" - 20 splines)	1
14	6328	Spring washer	1
15	6329	Lock nut M40 x 1.5 H9	1
16	6330	Casing	1
17	6331	Plug 3/8" gas (drain plug)	1
18	6332	Oil seal 45 x 72 x 8	1
19	6333	External circlip 50 UNI7435	1
20	6334	Gear Z21	1
21	6335	Shim	2
22	30210-A	Bearing: cone & cup	1
24	6338	Cover	1
25	6339	Oil seal 50 x 72 x 8	1
26	6331	Plug 3/8" gas (oil level)	2
27	6331	Plug 3/8" gas (oil filling)	1

10

REDUCTION GEAR BOX # 9769 PRH-30M-2

Oil volume required: 1.2 liters
Use XLEP-68/320 oil or equivalent.

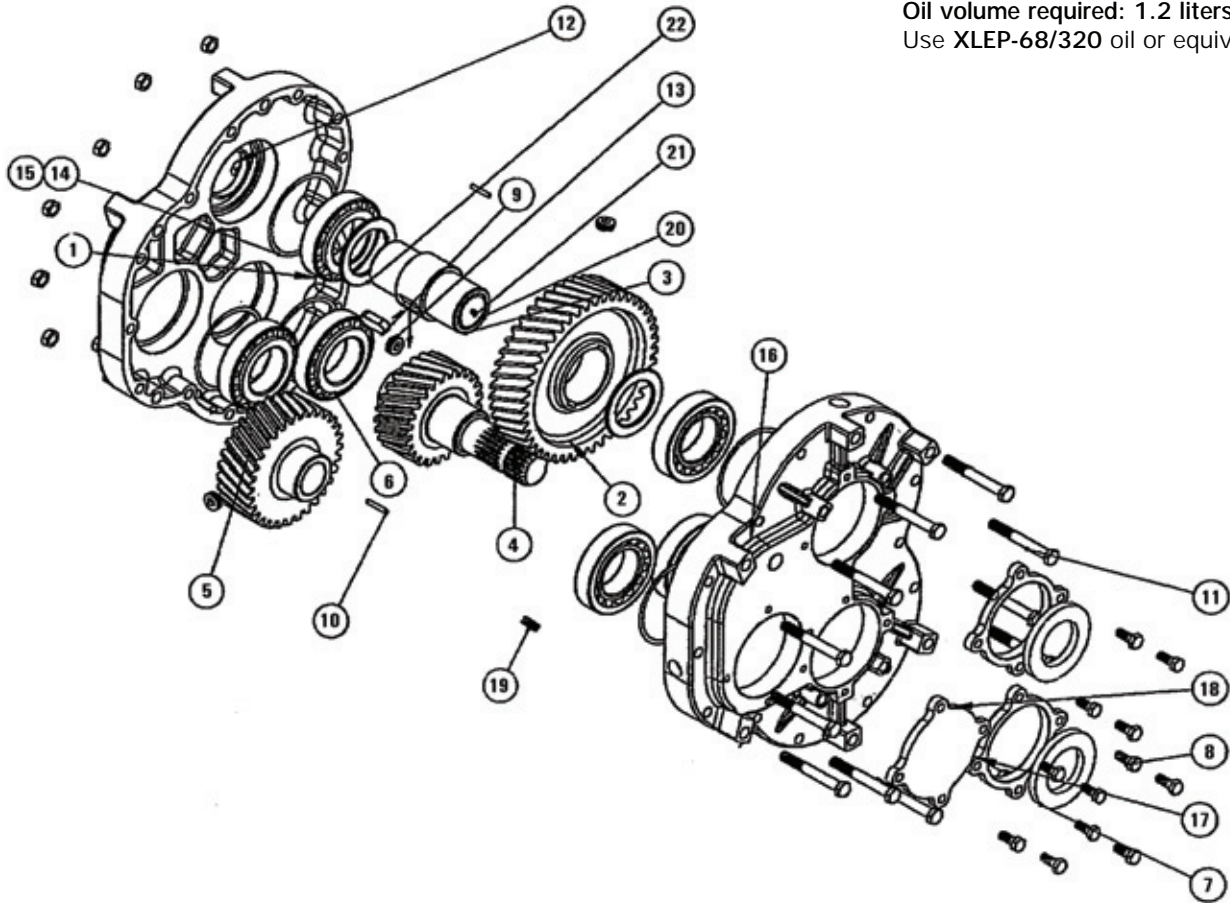

REF.	#PART	DESCRIPTION	QTY
1	9770	Half casing	1
2	9771	Gear	2
3	9772	Splined adaptor 1 3/4" - 20	1
4	9773	Input shaft with gear	1
5	9774	Gear	1
6	NTN4T-32212U	Tapered roller-bearing	6
7	9775	Oil seal 60 mm x 100 x 10	3
8	Std.	Bolt M10 x 25	12
9	9776	Key M6 x 10 x 40	2
10	9777	Pin	2
11	Std.	Bolt M12 x 95	11
12	Std.	Nut M12	11
13	9778	Plug	1
14	9779	Shim	12
15	9780	Shim	12
16	9781	Half casing	1
17	9782	Hollow cap	2
18	9783	Solid cap	1
19	9784	Plug	6
20	9785	Cover	1
21	Std.	Grease fitting	1
22	9786	Spacer	1

SPEED REDUCER # 9721 - 200 HP PR3G-200-2

Oil volume required: 0.9 liters
Use XLEP-68/320 oil or equivalent.

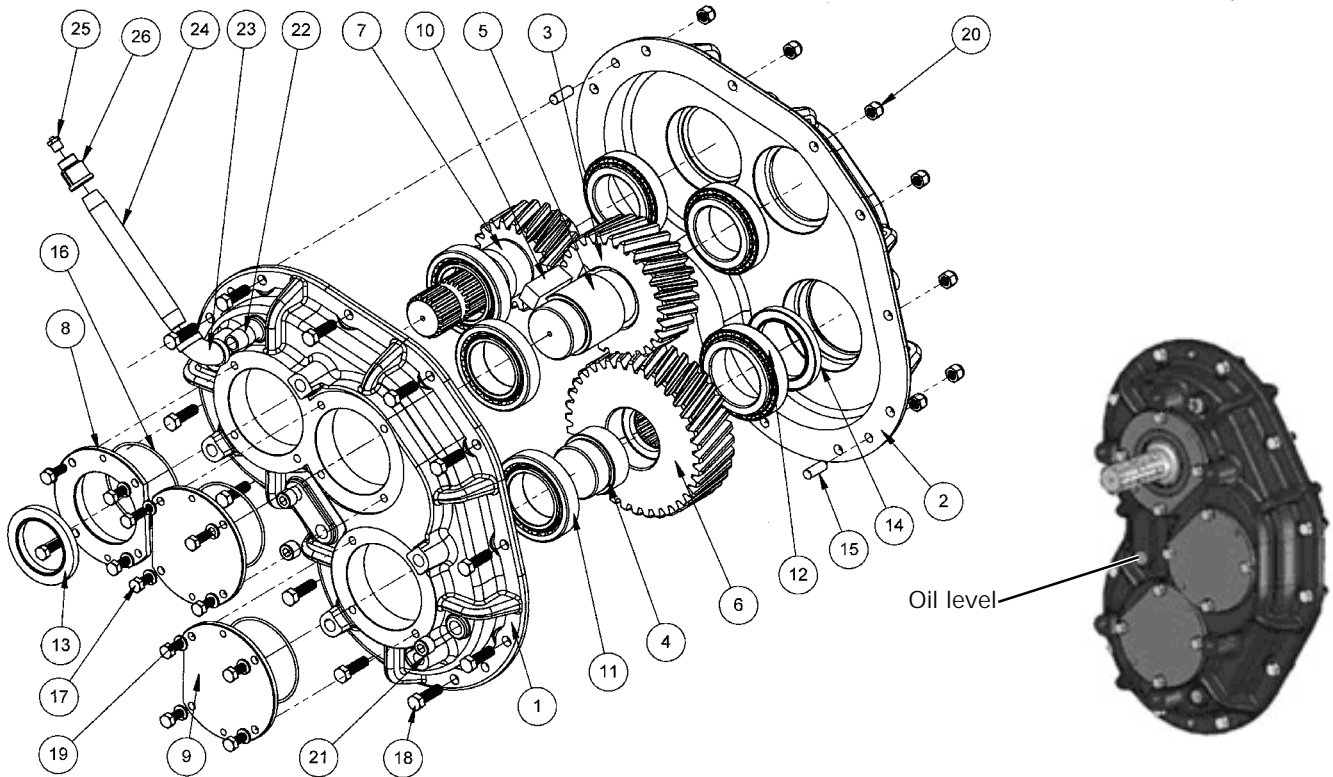

REF.	PART #	DESCRIPTION	QTY
1	9752	Half casing	1
2	8753	Half casing	1
3	9754	Helical gear with the teeth inclined to the right (28 teeth)	1
4	9756	Adaptor	1
5	9755	Intermediate shaft	1
6	9757	Helical gear with the teeth inclined to the left (36 teeth)	1
7	9758	Shaft with helical gear with the teeth inclined to the left (20 teeth)	1
8	9759	Open cover	1
9	9760	Closed over	2
10	9761	Square key 0.750 x 2.000	1
11	9762	Metric taper roller bearing with cup	5
12	9763	Metric taper roller bearing with cup	1
13	9764	Oil seal	1
14	9765	Oil seal	1
15	9766	Goupille 3/8" x 1"	2
16	9767	Metric oil seal	3
17	300-34235	Bolt 5/16" NC x 7/8" lg	12
18	300-36280	Bolt 3/8" x 1 1/4" lg	12
19	371-34000	lock washer 5/16"	12
20	346-36000	Nylon locknut 3/8"	12
21	9706	Plug 3/8" NPT	3
22	9707	Pipe 3/8" x 1.5	1
23	9708	Albow 3/8" 90 deg.	1
24	9709	Pipe 3/8" x 6	1
25	9710	Vent plug 1/8" 5 PSI	1
26	9711	Adaptor 3/8" - 1/8" NPT	1

CYLINDER 25TR08

15050

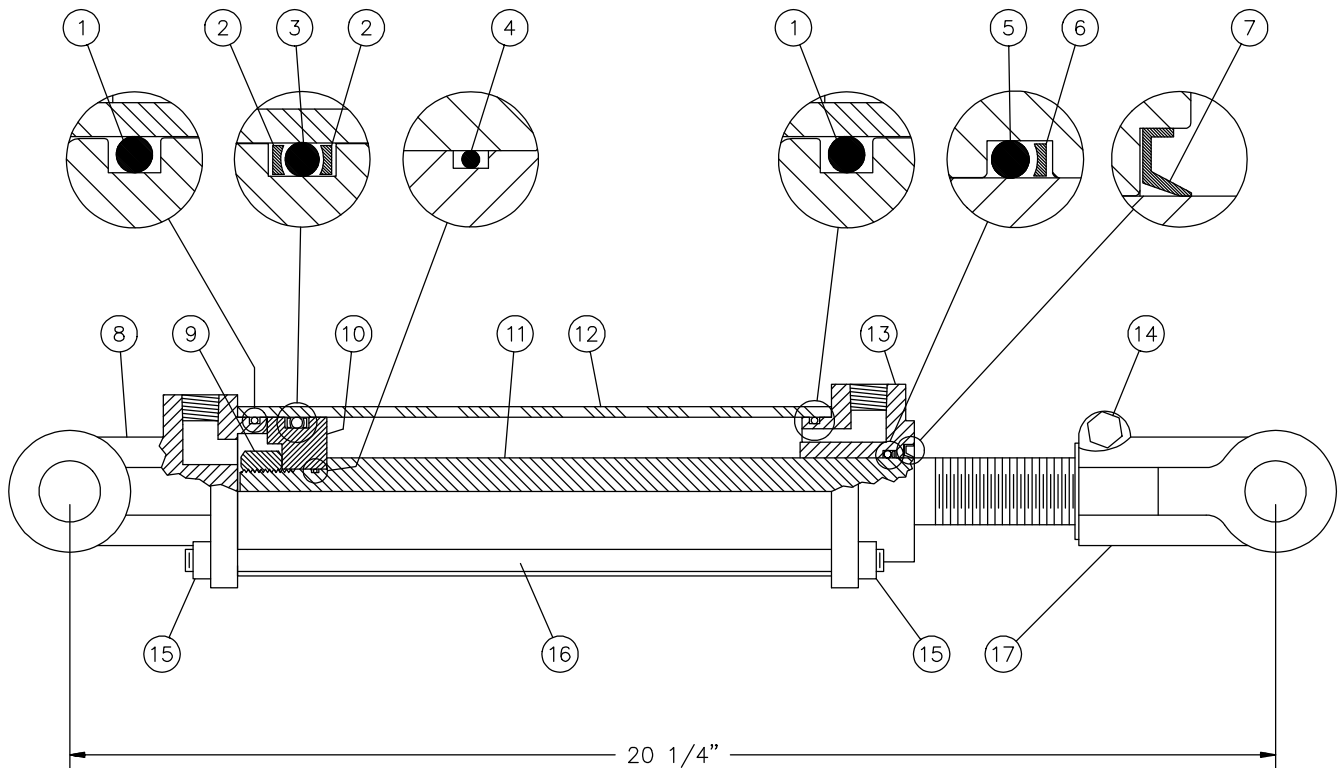

REF.	PART #	DESCRIPTION	QTY
1	See #RK25TR	O-ring 1/8" x 2 1/4" x 2 1/2"	2
2	See #RK25TR	Back-up 2 1/2" o.d. x 3/16 ø	2
3	See #RK25TR	O-ring 3/16" x 2 1/8" x 2 1/2"	1
4	See #RK25TR	O-ring 1/16" x 5/8" x 3/4"	1
5	See #RK25TR	O-ring 1/8" x 1 1/8" x 1 3/8"	1
6	See #RK25TR	Back-up 1 3/8" o.d. x 1/8" ø	1
7	See #RK25TR	Wiper 1 1/8" i.d. x 1 5/8" o.d.	1
8	492401	Yoke (for 2 1/2" tube)	1
9	339-46000	Nut 3/4" NF	1
10	4924-31	Piston 2 1/2" ø	1
11	491980	Piston rod 1 1/8"	1
12	491668	Cylinder body 2 1/2" ø	1
13	492421	Head (for 2 1/2" tube)	1
14	301-36355	Bolt 3/8" NC x 2 1/4" lg + nut	1
15	377-36000	Nut 3/8" NC	8
16	Std.	Threaded rod 3/8" NC x 12" lg	4
17	458599	Yoke (for 1 1/8" rod)	1
NI*	8183	Pin 1" ø + cotter pin	2
NI*	RK25TR	Repair kit for cylinder 2 1/2" (includes # 1, 2, 3, 4, 5, 6, & 7)	1

*NI = NOT ILLUSTRATED

EXTENSION CYLINDER 15PC32

170-04361

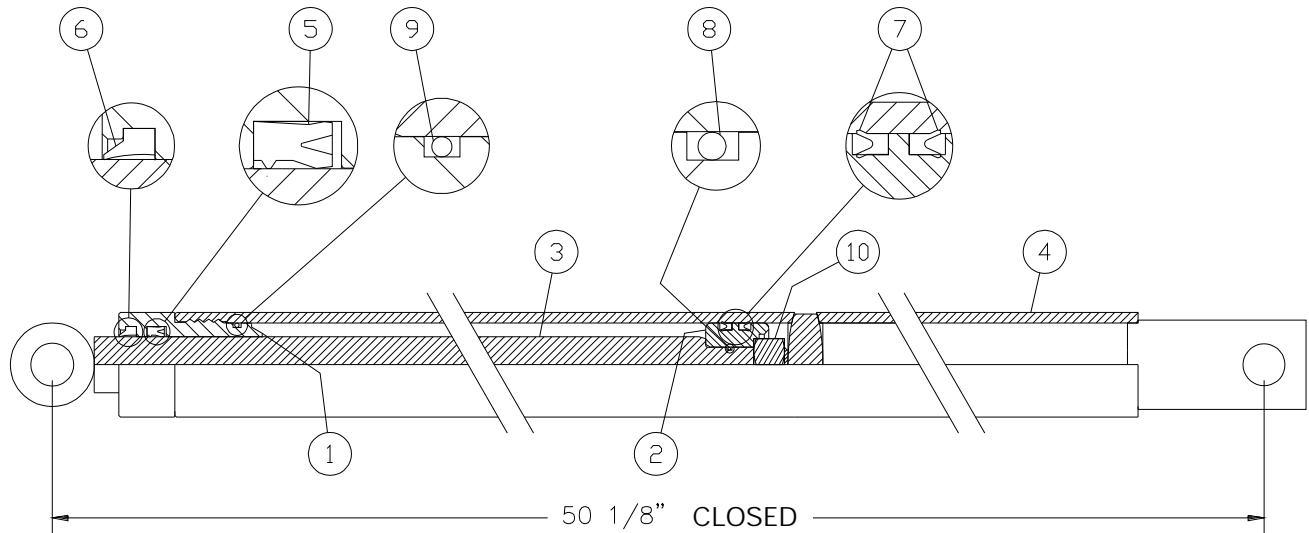

REF.	PART #	DESCRIPTION	QTY	
			15PC32D	15PC32G
1	150-06561	Head 1 1/2" dia.	1	1
2	150-06571	Piston 1 1/2" dia.	1	1
3	110-26561	Piston rod 1" dia.	1	1
4	110-29631	Cylinder body 1 1/2" dia. (15PC32D)	1	-
4	110-29632	Cylinder body 1 1/2" dia. (15PC32G)	-	1
5	DRTU-18-1.00-31	«U» seal 3/16" x 1" x 1 3/8"	1	1
6	ST-100	Wiper 3/16" x 1" x 1 3/8"	1	1
7	DSU12-1.25-18	«U» seal 3/16" x 1 1/4" x 1 1/2"	2	2
8	OR-014	O-ring 1/16" x 1/2" x 5/8"	1	1
9	OR-125	O-ring 3/32" x 1 5/16" x 1 1/2"	1	1
10	336-44000	Nut 5/8" NC	1	1
NI*	9689	Repair kit (includes # 5, 6, 7, 8 & 9)	1	1

*NI = NOT ILLUSTRATED

10

DEFLECTOR CYLINDER 15L12

170-05801

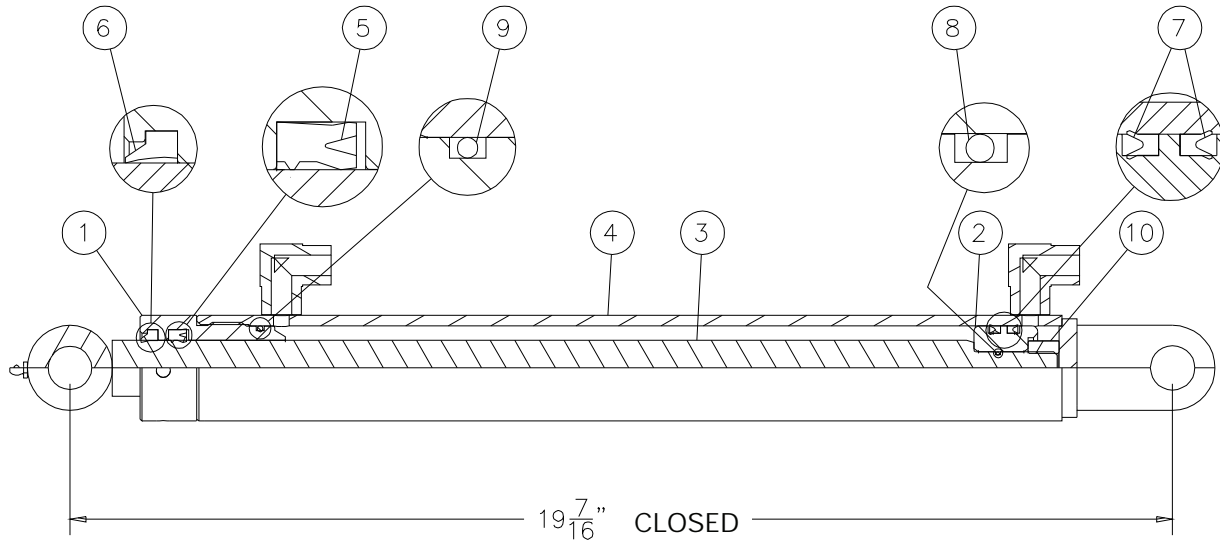

REF.	PART #	DESCRIPTION	QTY
1	150-06561	Head 1 1/2" dia.	1
2	150-06571	Piston 1 1/2" dia.	1
3	110-43122	Piston rod 1" dia.	1
4	110-43101	Cylinder body 1 1/2" dia.	1
5	DRTU-18-1.00-31	«U» seal 3/16" x 1" x 1 3/8"	1
6	ST-100	Wiper 3/16" x 1" x 1 3/8"	1
7	DSU12-1.25-18	«U» seal 3/16" x 1 1/4" x 1 1/2"	2
8	OR-014	O-ring 1/16" x 1/2" x 5/8"	1
9	OR-125	O-ring 3/32" x 1 5/16" x 1 1/2"	1
10	336-44000	Nut 5/8" NC	1
NI*	9689	Repair kit (includes # 5, 6, 7, 8 & 9)	1

*NI = NOT ILLUSTRATED

HYDRAULIC MOTOR # MLH-250 & MLH-315

CUSHION VALVE H110

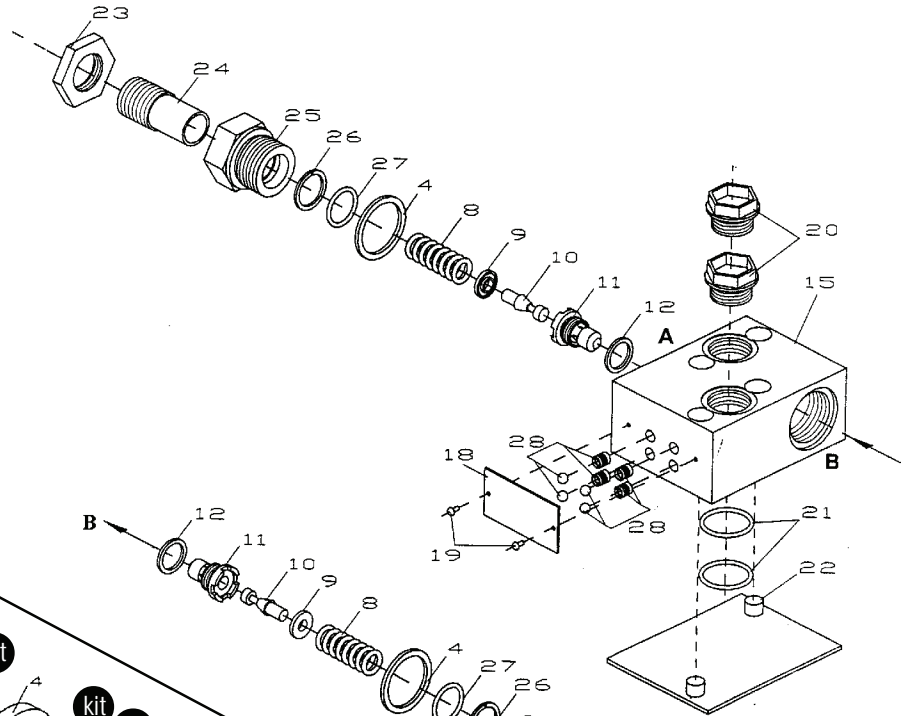

MOTOR

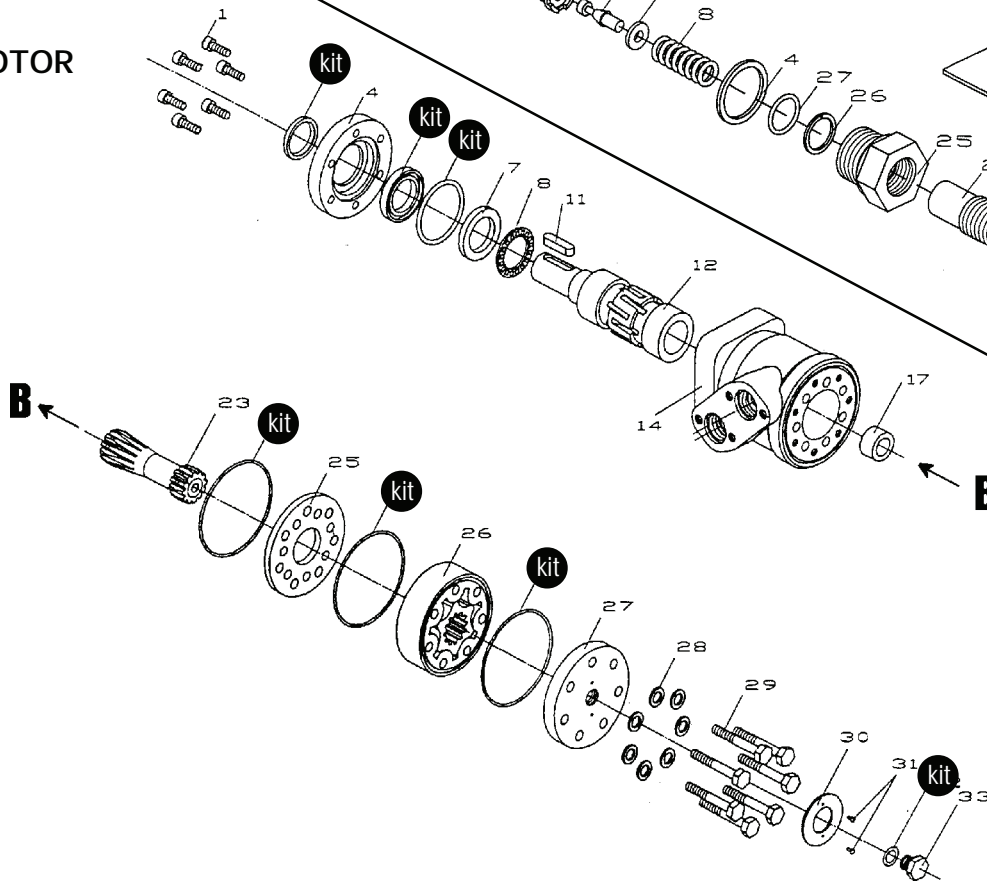







10





REF.	PART #	DESCRIPTION	QTY
kit	8368	Set of seals.....	1
11	8369	Key for "Orbit" motor.....	1

TORQUE CHART

TORQUE SPECIFICATION TABLE

Thread UNC and UNF		Grade 2 				Grade 5   				Grade 8*   			
Bolt size		Torque				Torque				Torque			
Inches	mm	Pound feet min.	max.	Newton meters min.	max.	Pound feet min.	max.	Newton meters min.	max.	Pound feet min.	max.	Newton meters min.	max.
1/4	6.35	5	6	6.8	8.13	9	11	12.2	14.9	12	15	16.3	30.3
5/16	7.94	10	12	13.6	16.3	17	20.5	23.1	27.8	24	29	32.5	39.3
3/8	9.53	20	23	27.1	31.2	35	42	47.5	57.0	45	54	61.0	73.2
7/16	11.11	30	35	40.7	47.4	54	64	73.2	86.8	70	84	94.9	113.9
1/2	12.70	45	52	61.0	70.5	80	96	108.5	130.2	110	132	149.2	179.0
9/16	14.29	65	75	88.1	101.6	110	132	149.2	179.0	160	192	217.0	260.4
5/8	15.88	95	105	128.7	142.3	150	180	203.4	244.1	220	264	298.3	358.0
3/4	19.05	150	185	203.3	250.7	270	324	366.1	439.3	380	456	515.3	618.3
7/8	22.23	160	200	216.8	271.0	400	480	542.4	650.9	600	720	813.6	976.3
1	25.40	250	300	338.8	406.5	580	696	786.5	943.8	900	1080	1220.4	1464.5
1 1/8	25.58	-	-	-	-	800	880	1084.8	1193.3	1280	1440	1735.7	1952.6
1 1/4	31.75	-	-	-	-	1120	1240	1518.7	1681.4	1820	2000	2467.9	2712.0
1 3/8	34.93	-	-	-	-	1460	1680	1979.8	2278.1	2380	2720	3227.3	3688.3
1 1/2	38.10	-	-	-	-	1940	2200	2630.6	2983.2	3160	3560	4285.0	4827.4

* Thick nuts must be used with grade 8 bolts.

Size of screw	Thread	Pitch (mm)	Grade 4T  				Grade 7T 				Grade 8T  			
			Torque				Torque				Torque			
			Pound feet min.	max.	Newton meters min.	max.	Pound feet min.	max.	Newton meters min.	max.	Pound feet min.	max.	Newton meters min.	max.
M6	UNC	1.00	3.6	5.8	4.9	7.9	5.8	9.4	7.9	12.7	7.2	10	9.8	13.6
M8	UNC	1.25	7.2	14	9.8	19	17	22	23	29.8	20	26	27.1	35.2
M10	UNC	1.5	20	25	27.1	33.9	34	40	46.1	54.2	38	46	51.5	62.3
M12	UNC	1.75	28	34	37.9	46.1	51	59	69.1	79.9	57	66	77.2	89.4
M14	UNC	2.0	49	56	66.4	75.9	81	93	109.8	126	96	109	130.1	147.7
M16	UNC	2.0	67	77	90.8	104.3	116	130	157.2	176.2	129	145	174.8	196.5
M18	UNC	2.0	88	100	119.2	136	150	168	203.3	227.6	175	194	237.1	262.9
M20	UNC	2.5	108	130	146.3	176.2	186	205	252	277.8	213	249	288.6	337.4
M8	UNF	1.0	12	17	16.3	23	19	27	25.7	36.6	22	31	29.8	42
M10	UNF	1.25	20	29	27.1	39.3	35	47	47.4	63.7	40	52	54.2	70.5
M12	UNF	1.25	31	41	42	55.6	56	68	75.9	92.1	62	75	84	101.6
M14	UNF	1.5	52	64	70.5	86.7	90	106	122	143.6	107	124	145	168
M16	UNF	1.5	69	83	93.5	112.5	120	138	162.6	187	140	158	189.7	214.1
M18	UNF	1.5	100	117	136	158.5	177	199	239.8	269.6	202	231	273.7	313
M20	UNF	1.5	132	150	178.9	203.3	206	242	279.1	327.9	246	289	333.3	391.6

Use the above torques when special torque is not given.

NOTE: These values apply to fasteners as received from supplier, dry, or when lubricated with normal engine oil. They do not apply if extreme pressure lubricants are used.

WARRANTY

12

PRONOVOST warrants this product to the initial purchaser for the period of one year from the date of purchase against defects in materials and workmanship.

We will replace or repair defective parts free of charge if they are returned to our plant in St-Tite, Quebec, Canada.

Transportation charges are the responsibility of the customer. This warranty is not transferable.

Hydraulic cylinders and motors are covered by the manufacturer of these items.

The PTO shafts are warranted by the manufacturer and cover **only** defects in material and workmanship, and is conditional to recommended use and installation only.

All PRONOVOST spare parts purchased are covered by a three (3) month warranty.

This warranty becomes void and nul if the equipment is modified, breaks down as the result of an accident, is not operated according to manufacturer's recommendations, damaged by negligence or if maintenance has not been carried out as specified.

Our obligation is limited to the replacement or repair of the defective part. PRONOVOST accepts no responsibility for direct or indirect consequential damages of any kind.

Ce manuel est aussi disponible en français.
Veuillez téléphoner.



LES MACHINERIES PRONOVOST INC.
260, Haut du Lac Sud (route 159),
Saint-Tite, Quebec, Canada, G0X 3H0
Tel.: (418) 365-7551, Fax: (418) 365-7954
www.pronovost.qc.ca