

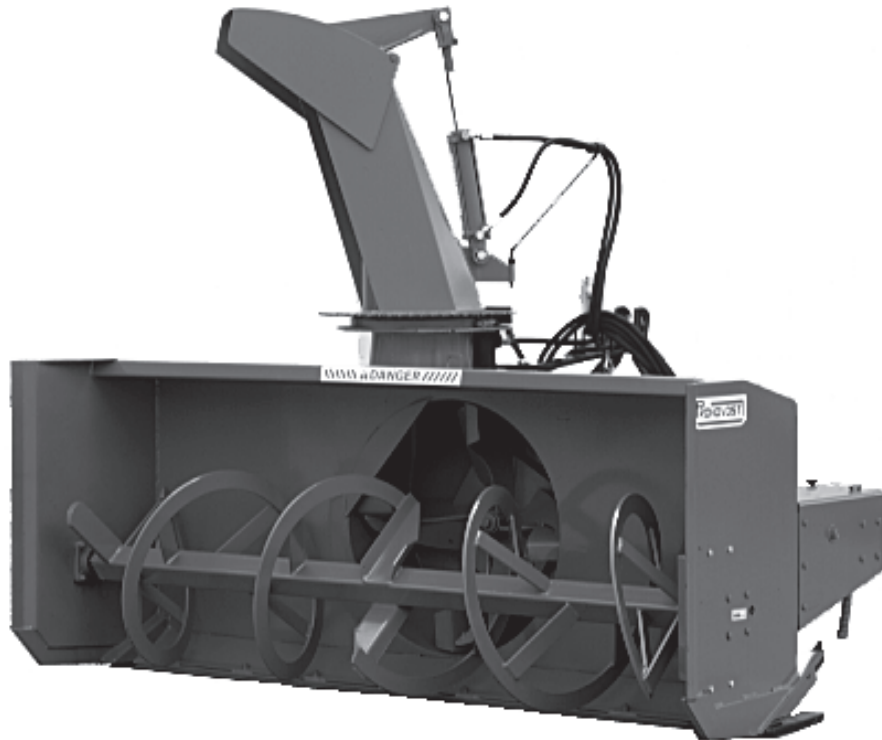

**OPERATOR'S / PARTS
MANUAL**



Snowblowers
Models

P-740 & P-740TRC

P-860 & P-860TRC

P-800 & P-800TRC

P-862 & P-862TRC

P-860-92 & P-860TRC-92



Copyright © Les Machineries Pronovost Inc., 2001

All rights reserved.
Printed in Canada.

TABLE OF CONTENTS

Section	Item	Page
1	Introduction	5
2	Safety	6
	General Safety	6
	Safety in Operation	6
	Safety with Maintenance	7
	Safety in Transport	7
	Safety in Storage	7
3	Decals	8
	Safety Decals	8
	Maintenance Decals	10
4	Assembly	11
	General assembly	11
5	Start-up	12
	Basic Start-up Procedures	12
6	Maintenance	13
7	Storage	14
8	Trouble Shooting	15
9	Specifications	17
10	Parts List	18
	Snowblowers P-740 P-800 P-860 P-860-92	18
	Snowblowers P-740TRC P-800TRC P-860TRC P-860TRC-92	21
	Snowblower P-862	25
	Snowblower P-862TRC	28
	Semi-industrial Chute PSI-7486	32
	Industrial Chute PC-7486	33
	Options	34
	P.T.O. Shaft 8114-EG	36
	P.T.O. Shaft 8202 8202-1	37
	P.T.O. Shaft 9225-EG 9225-1 9569	38
	Gear Box 8251	39
	Réducteur de vitesse 9575 8348	40
	Cylinder 25TR08	41
	Hydraulic Motor DH 250 & DH 315	42
11	Torque Chart	43
12	Warranty	44

INTRODUCTION

CONGRATULATIONS!

Thank you for choosing PRONOVOST. We are confident this equipment will meet your requirements in terms of quality, performance and reliability.

This manual was prepared to assist you in the safe operation of your new Snowblower. It contains important information which will help you achieve excellent returns with your Snowblower for years to come.

Please read this manual completely before operating your Snowblower and keep it for future reference.

Before starting the machine, you or any other person who will be operating the Snowblower must familiarize yourself with the safety recommendations and the operating instructions. Please read carefully and be sure to understand and follow all recommendations and procedures.

In this manual, the right and left sides are identified as shown on Figure 1.

If you require additional information on your Snowblower, please contact your PRONOVOST Dealer.

NOW take a moment to enter the model, serial number and the date of purchase of your Snowblower in the space provided.

When ordering parts from your Dealer, please refer to these numbers for a fast and efficient service. Use PRONOVOST parts for replacement.

The model and serial numbers are on the name plate shown on Fig. 1.

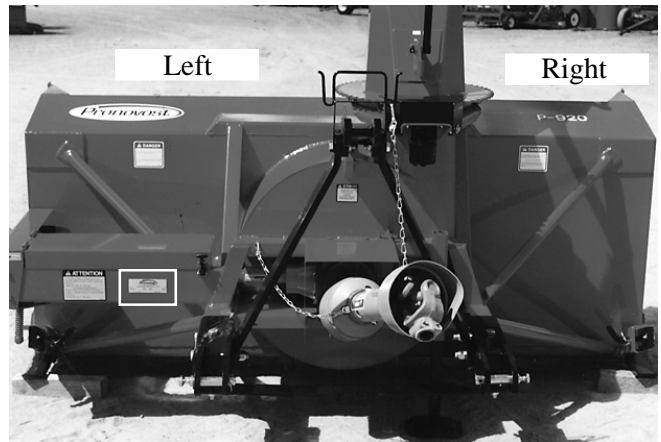

Figure 1

MODEL: _____

SERIAL NO: _____

DATE OF PURCHASE: _____

SAFETY

GENERAL SAFETY

2

WHEN YOU SEE THIS SYMBOL



ATTENTION!

**BE ALERT
YOUR SAFETY IS INVOLVED**

This symbol «SAFETY ALERT» is used in this manual and on the safety decals on the Snowblower. It warns you of the possibility of danger. Carefully read, understand and follow all safety recommendations before operating the Snowblower.

- 1) Careful operation is the best assurance against accidents. Carefully read this manual and follow all recommendations before operating your Snowblower. It is the owner's responsibility to make sure that anyone who will operate the Snowblower will read this manual before operating the equipment.
- 2) Familiarize yourself with all controls and always be ready to stop the Snowblower quickly in case of emergency.
- 3) Never let a child operate the Snowblower.
- 4) Do not modify the Snowblower. Any non authorized modification may affect the efficiency and/or safety of the equipment and will automatically void the warranty.
- 5) Never operate the Snowblower with defective parts or if damaged in any way. Have it repaired before operating.
- 6) Make sure all fasteners are in place and properly secured or tightened. Refer to torque chart on page 43.
- 7) Avoid wearing loose fitting clothing when working with the Snowblower. These could get entangled in moving parts of the equipment and cause accidents.

- 8) Prolonged exposure to noise may hamper hearing. Protect yourself by wearing adequate protection devices.
- 9) Hydraulic fluids under pressure can damage your skin. Do not use your hands to locate a leak.
- 10) Before the beginning of the snow season, inspect all areas where the Snowblower will be used and remove any object which may cause an accident and/or damage the equipment.
- 11) Never operate your Snowblower in poor visibility or without proper lighting conditions.

SAFETY IN OPERATION

- 1) Be sure there are no obstructions around the equipment and that no one stands near the equipment when in operation.
- 2) Do not operate an engine in a confined or non ventilated area.
- 3) Do not perform any adjustments, cleaning, maintenance or repairs with the engine running. The engine must be stopped and the P.T.O. disengaged. Preferably remove the key from the ignition.
- 4) Wear adequate clothing when working in cold or windy conditions.
- 5) Adjust skid shoes for proper ground clearance of scraper blade, especially in rough terrain or soft ground conditions.
- 6) Before operating, make sure the P.T.O. is properly installed and secured.
- 7) Before starting-up the Snowblower, make sure the auger and drum areas are free of ice.
- 8) Put P.T.O. control in neutral position before starting engine.
- 9) Keep hands, feet and clothing away from moving parts of the Snowblower. Stay away from the discharge chute.

SAFETY (cont'd)

- 10) Before unplugging the chute, always disengage the P.T.O., stop the engine and relieve all hydraulic pressures.
- 11) Do not operate in excessive inclined conditions. Be careful when turning in slopes.
- 12) Never operate your Snowblower with missing guards or without protective devices in place.
- 13) Do not operate your Snowblower near buildings, windows or other vehicles without prior and proper adjustment of the chute deflector.
- 14) Never aim discharge chute towards people or animals. This may cause serious injuries.
- 15) Always reduce operating speed in slippery conditions.
- 16) Be careful when backing-up, make sure you have good visibility.
- 17) Always be on the lookout for objects which may enter the Snowblower.
- 18) If undue vibrations are felt, disengage the P.T.O., stop the motor and look for the cause of the vibration. Vibration is usually the indication of a problem.
- 19) At the end of the operation, disengage the P.T.O., lower the Snowblower, put transmission in neutral, apply parking brake, stop engine and remove the key from the ignition.

SAFETY WITH MAINTENANCE

- 1) Perform the Snowblower maintenance according to recommendations contained in this manual.

- 2) Stop engine and relieve all hydraulic pressures before doing inspection, maintenance or repairs.
- 3) Never perform any work under the Snowblower while it is supported only by the tractor's hydraulic system. It must be completely supported by wooden blocks or other safe means.

SAFETY IN TRANSPORT

- 1) On public roads, use proper safety lights and check local regulations.
- 2) Be alert while driving on the road. Never carry passengers.
- 3) Always disengage P.T.O. while moving from one area of work to another.
- 4) It is recommended to use both brake pedals simultaneously for better control.
- 5) The recommended road speed should be such as to maintain full control over steering and braking.
- 6) Be careful while backing up, make sure you have good visibility.

SAFETY IN STORAGE

- 1) Provide adequate supports to prevent any accidental overturning of the Snowblower.
- 2) Do not let children play in the area where the snowblower is stored.

2

DECALS

SAFETY DECALS

The safety decals are affixed wherever special safety precautions are indicated. Locate them on the machine and read them carefully. If a decal is damaged, lost or illegible, install a new one. The following photos indicate where each one must be installed.

3

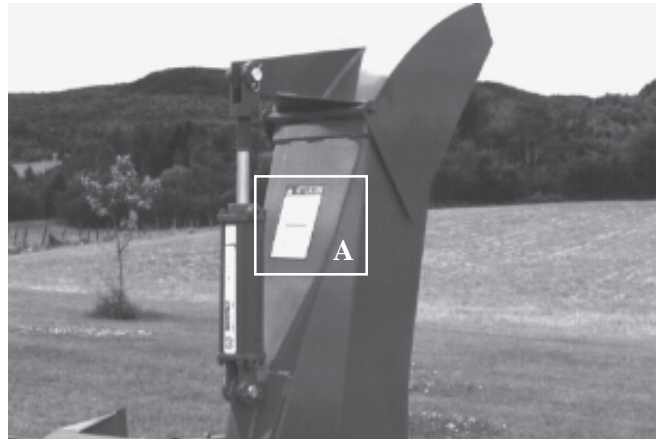

Figure 3

ATTENTION

- 1- FOR SAFE OPERATION, FOLLOW OPERATING INSTRUCTIONS IN OPERATOR'S MANUAL.
- 2- KEEP HANDS, FEET AND CLOTHINGS AWAY FROM POWER DRIVEN PARTS.
- 3- STOP ENGINE BEFORE LEAVING THE EQUIPMENT.
- 4- MACHINE HAS TO BE COMPLETELY STOPPED BEFORE STARTING TO ADJUST OR LUBRICATE.
- 5- KEEP PEOPLE AND PETS AT SAFE DISTANCE FROM MACHINE.
- 6- KEEP ALL GUARDS AND SHIELDS IN PLACE.

- 1- POUR UN FONCTIONNEMENT SÉCURITAIRE SUIVRE LES INSTRUCTIONS DANS LE MANUEL D'OPÉRATION.
- 2- GARDER LES MAINS, PIEDS ET VÊTEMENTS ÉLOIGNÉS DES ÉLÉMENTS MOBILES OU ROTATIFS.
- 3- AVANT DE QUITTER LA MACHINE ARRÊTER LE MOTEUR.
- 4- ARRÊTER COMPLÈTEMENT LA MACHINE POUR EFFECTUER L'ENTRETIEN ET L'AJUSTEMENT.
- 5- GARDER LES GENS ET LES ANIMAUX À UNE DISTANCE SÉCURITAIRE.
- 6- GARDER TOUS LES ÉCRANS PROTECTEUR EN PLACE.

PA 93-01

Figure 2
Decal A

Part no.: A102

DANGER

TO AVOID SERIOUS INJURIES, KEEP CLEAR OF EQUIPMENT WHILE IN OPERATION.

POUR ÉVITER DES BLESSURES GRAVES SE TENIR LOIN DE CET ÉQUIPEMENT LORSQU'IL EST EN MARCHÉ.

PD 93-03

Figure 4
Decal B

Part no.: A101



Figure 5

DECALS (cont'd)

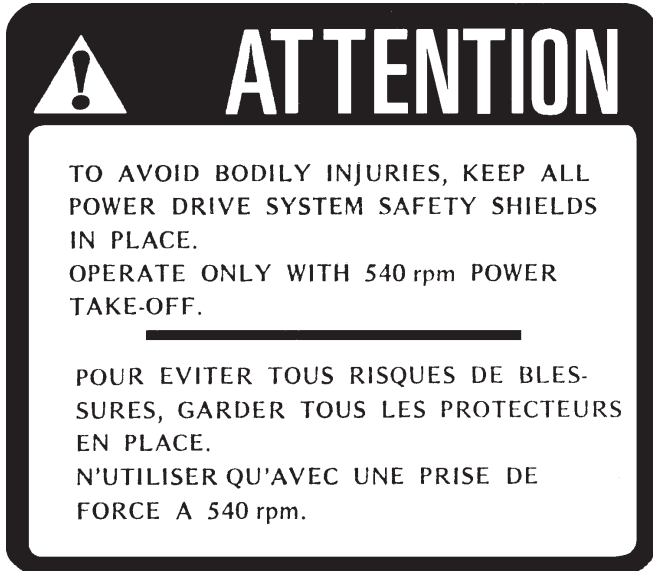

Figure 6
Decal C Part no.: A107



Figure 7
Decal D Part no.: A103

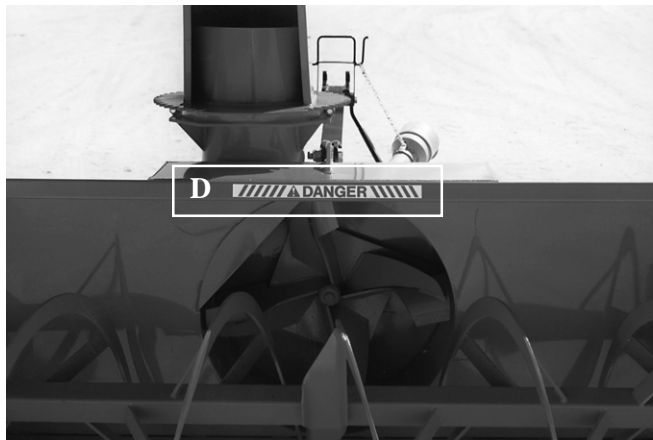

Figure 8

Decal E in Fig. 9 is located directly on the P.T.O. shaft. It is not visible when the safety shield is in place. It must never be visible when you operate the equipment.



Figure 9
Decal E Part no.: A108

3

DECALS (cont'd)

3



Figure 10
Decal F

Part no.: A 109

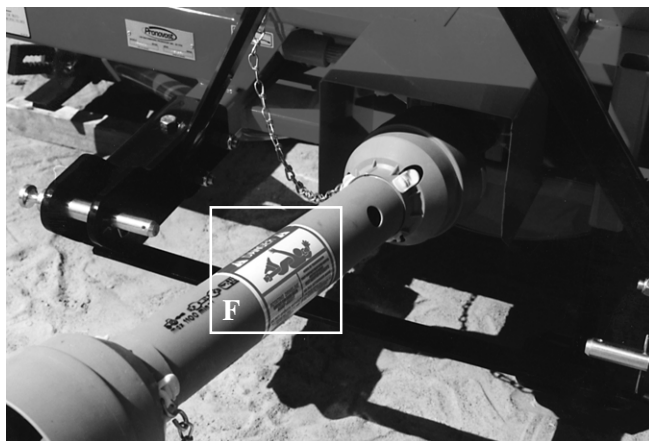
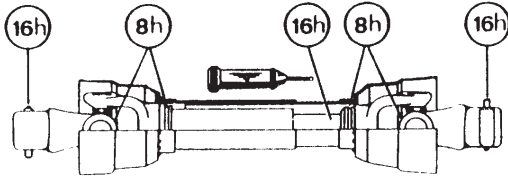

Figure 11

MAINTENANCE DECALS

The maintenance decals indicate the points requiring lubrication. Refer to maintenance section for more details.

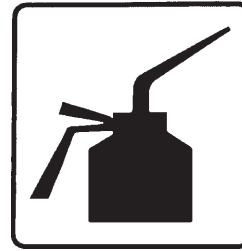

Figure 12

Part no.: A 105



Figure 13

Part no.: A 106



Figure 14
Decal G

Part no.: A104

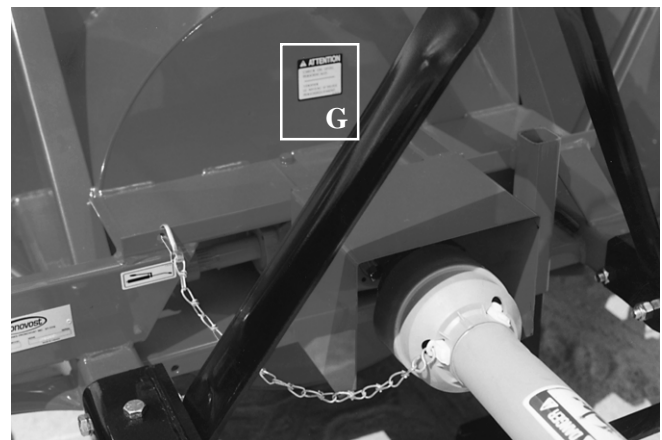

Figure 15

ASSEMBLY



Figure 16



Figure 17

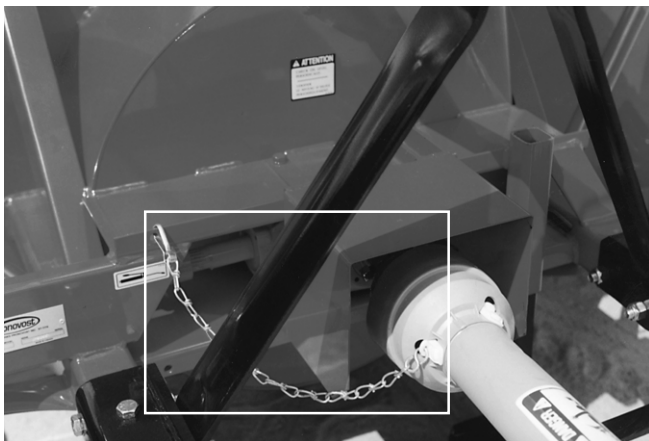

Figure 18

ASSEMBLY

- 1) The Snowblower is shipped partly assembled.
- 2) Install 3-point system according to the model of your Snowblower. (See section 10 for parts numbers). Use the holes most convenient to the type of tractor used (Fig. 16).
- 3) Install P.T.O. shaft with the shear pin end onto the Snowblower gear box (Fig. 17). Then attach safety shield support chain as shown (Fig. 18).
WARNING: The telescoping tubes of the drive shaft must never be allowed to bottom out while maintaining a minimum overlap of 6 inches.
- 4) If you install a hydraulic cylinder on the chute deflector, use model 25TR08 cylinder.
- 5) If equipped with a rotating drum, install a hydraulic cylinder model 25TR08.
- 6) Install the chute rotation mechanism.

4

STARTING-UP

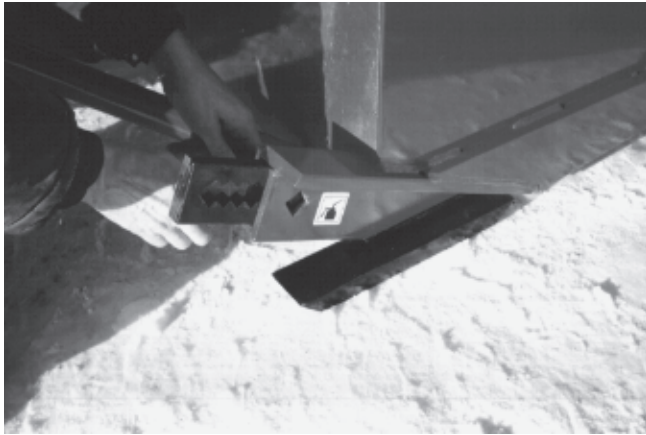

Figure 23

5

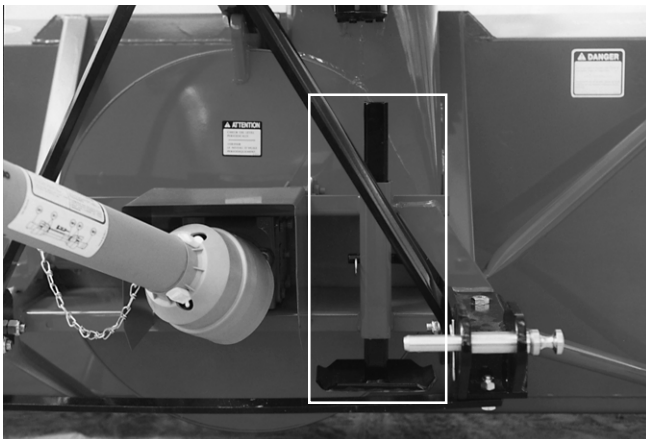

Figure 24



Figure 25

START-UP PROCEDURES

- 1) Check oil level in gearbox. Use S.A.E. W90 gear box oil.
- 2) Lubricate all points with a good quality multipurpose grease.
- 3) Check chain take-up adjustment. The spring maintaining the tension must be compressed to a length between 2 3/4" and 3 1/2".
- 4) Verify for adequate tightness of all fastening devices. Refer to torque chart on page 43.
- 5) Adjust skid shoes according to ground conditions (Fig. 23).
- 6) Following the installation of the Snowblower on the tractor, **do not forget** to lift the storage support (Fig. 24).
- 7) Make sure of a 540 RPM input to your snowblower.
- 8) Check impeller adjustment. The tip of the blades should be approximately 1/8" to 3/16" from the discharge wall of the drum. If necessary, adjust with the take-up screws provided (Fig. 25).

MAINTENANCE

- 1) Wipe off all grease fittings with a clean cloth before adding grease in order to avoid injecting dirt and sand.
- 2) Repair or replace damaged grease fittings.
- 3) Lubricate all grease fittings every 10 hours of operation.
- 4) Oil drive chain every 8 hours of operation.
- 5) Lubricate P.T.O. shaft as indicated below:

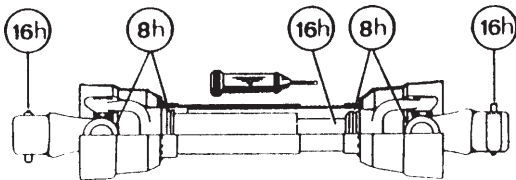

Pull out the P.T.O. and lubricate between the two tubes with low temperature grease.

- 6) Check oil level in gear box once a month. If necessary add oil.
- 7) Check tension of drive chain every 25 hours of operation and adjust if necessary.
- 8) Check for tightness of bearing collars every 50 hours of operation.
- 9) Change gearbox oil once a year. Use gear box oil S.A.E. W90 rated API, class GL-5.
- 10) Check all nuts and bolts once a year. If necessary use torque chart on page 43.
- 11) Standard scraper blades are reversible. Reverse when one edge is worn out.
- 12) Always use Grade 5 shear bolts.

STORAGE

- 1) Store the Snowblower in a cool, dry place.
- 2) Support the Snowblower with wooden blocks.
- 3) Keep all piston rods in the retracted position. This will assure better protection against the elements.
- 4) Clean your Snowblower.
- 5) Thoroughly inspect all parts of the Snowblower. Replace or repair worn or defective parts.
- 6) Touch-up or repaint if necessary.
- 7) Lubricate all points before storage.

TROUBLESHOOTING

P.T.O. SHAFT

PROBLEM	POSSIBLE CAUSE	CORRECTION
<ul style="list-style-type: none"> - Premature wear of U-joints and/ or bluish color of cross journals. 	<ul style="list-style-type: none"> - Insufficient lubrication. - Excessive working angle. 	<ul style="list-style-type: none"> - Follow lubrication recommendations. - Replace defective U-joints. - Make sure the snowblower inlet face is perpendicular to the ground and if possible readjust 3-point hitch in order to position the snowblower further away from tractor.
<ul style="list-style-type: none"> - Gripping or premature wear of telescoping members. 	<ul style="list-style-type: none"> - Too much sliding under load. - Tube overlap too-short: minimum recommended is 6". - Insufficient lubrication. - Contaminants (sand, etc.). 	<ul style="list-style-type: none"> - Avoid raising snowblower while in operation. - Readjust 3-point hitch in order to position the snowblower closer to the tractor. - Follow lubrication recommendations. - Replace defective telescopic members.
<ul style="list-style-type: none"> - Damaged or jammed locking pin or bolt. 	<ul style="list-style-type: none"> - Pin or orifice contaminated by sand, ice, etc. - Telescoping members too long, exerting pressure on locking device. 	<ul style="list-style-type: none"> - Clean and grease. - Readjust 3-point hitch in order to position the snowblower further away from tractor.
<ul style="list-style-type: none"> - Premature wear of guard tube bearing ring. 	<ul style="list-style-type: none"> - Lack of lubrication. - Wrong installation of guard chain. - Part of the guard in contact with the equipment. 	<ul style="list-style-type: none"> - Follow lubrication instructions. - Adjust chain to prevent interference between guard & equipment. - Replace worn or damaged bearing rings.
<ul style="list-style-type: none"> - Cut or deformed safety guard tubes. 	<ul style="list-style-type: none"> - Tubes in contact with the equipment. 	<ul style="list-style-type: none"> - Eliminate any interference between tubes and equipment or tractor. - Replace damaged tubes.

TROUBLESHOOTING (cont'd)

SNOWBLOWER

PROBLEM	POSSIBLE CAUSE	CORRECTION
- The snow is not being thrown as far as usual.	- Tractor RPM too low. - Gap too wide between impeller blade tip and drum outlet wall. - Insufficient tractor HP.	- Raise P.T.O. speed to a minimum of 540 RPM. - Adjust impeller blades closer to drum outlet (1/8" to 3/16"). - Reduce travel speed.
- Frequent plugging of discharge chute.	- Tractor RPM too low. - Tractor RPM reduced too early with snow still in the snowblower. - Slippage of PTO clutch mechanism. - Wet snow condition.	- Raise P.T.O. speed to a minimum of 540 RPM. - Make sure the snowblower is completely empty before reducing RPM, especially on tractors with foot controlled RPM. - Repair clutch. - Reduce travel speed.
- The impeller will not turn.	- Shear bolt broken on drive shaft.	- Replace shear bolt.
- The auger will not turn.	- Shear bolt broken on drive shaft. - Shear bolt broken on auger drive shaft. - Broken drive chain.	- Replace shear bolt. - Replace shear bolt. - Fix or replace chain.
- The rotating drum will not turn.	- Rotating drum shear bolt broken. - Ice accumulation. - Wrong hydraulic connections.	- Replace shear bolt. - Remove ice. - Check hydraulic connections.
- The chute will not turn.	- Ice accumulation. - Wrong hydraulic connections.	- Remove ice. - Check hydraulic connections.

8

SPECIFICATIONS

Snowblower model	P-740	P-740 TRC	P-800	P-800 TRC	P-860	P-860 TRC	P-860 -92	P-860 TRC-92	P-862	P-862 TRC	
Horse power recommended (HP) min - max	30-50	30-50	40-65	40-65	50-75	50-75	50-75	50-75	50-75	50-75	
Working width	(inches)	74"	74"	80"	80"	86"	86"	92"	92"	86"	86"
	(centimeters)	188	188	203	203	218	218	234	234	218	218
Cutting height	(inches)	34"	34"	34"	34"	36"	36"	36"	36"	41.5"	41.5"
	(centimeters)	86.5	86.5	86.5	86.5	91.5	91.5	91.5	91.5	105.5	105.5
Impeller diameter	(inches)	26"	26"	26"	26"	28"	28"	28"	28"	28"	28"
	(centimeters)	66	66	66	66	71	71	71	71	71	71
Depth of drum	(inches)	12"	12"	12"	12"	12"	12"	12"	12"	12"	12"
	(centimeters)	30.5	30.5	30.5	30.5	30.5	30.5	30.5	30.5	30.5	30.5
Impeller blades	4	4	4	4	4	4	4	4	4	4	
Size of impeller shaft	(inches)	1 9/16"	1 9/16"	1 9/16"	1 9/16"	1 9/16"	1 9/16"	1 9/16"	1 9/16"	1 9/16"	1 9/16"
	(centimeters)	3.97	3.97	3.97	3.97	3.97	3.97	3.97	3.97	3.97	3.97
Height - Impeller center	(inches)	16½"	16½"	16½"	16½"	17½"	17½"	17½"	17½"	17½"	17½"
	(centimeters)	41.9	41.9	41.9	41.9	44.5	44.5	44.5	44.5	44.5	44.5
Impeller RPM	540	540	540	540	540	540	540	540	540	540	
Number of augers	1	1	1	1	1	1	1	1	2	2	
Main auger diameter	(inches)	23"	23"	23"	23"	23"	23"	23"	23"	23"	23"
	(centimeters)	58	58	58	58	58	58	58	58	58	58
Upper auger 13"/33 cm dia.	-	-	-	-	-	-	-	-	Std.	Std.	
Drive chain - main auger	80	80	80	80	80	80	80	80	80	80	
Oil bath sealed gear box	Std.	Std.	Std.	Std.	Std.	Std.	Std.	Std.	Std.	Std.	
Chute rotation mechanism for hyd. motor	Std.	Std.	Std.	Std.	Std.	Std.	Std.	Std.	Std.	Std.	
Number of shear bolts	2	3	2	3	2	3	2	3	2	3	
Hitch category	1 & 2	1 & 2	1 & 2	1 & 2	1 & 2	1 & 2	1 & 2	1 & 2	1 & 2	1 & 2	
Balanced impeller	Std.	Std.	Std.	Std.	Std.	Std.	Std.	Std.	Std.	Std.	
Balanced auger	Std.	Std.	Std.	Std.	Std.	Std.	Std.	Std.	Std.	Std.	
Drum rotation mechanism	Hyd. cylinder	-	Std.	-	Std.	-	Std.	-	Std.	-	Std.
	Hyd. motor	-	-	-	-	-	-	-	-	-	-
1000 to 540 RPM reducer	-	-	-	-	-	-	-	-	-	-	
Scraper blades	Std. steel - not rev.	-	-	-	-	-	-	-	-	-	-
	Std. steel - rev.	Std.	Std.	Std.	Std.	Std.	Std.	Std.	Std.	Std.	
	Carbon steel 3/8" x 2½"	-	-	-	-	-	-	-	-	-	-
	Carbon steel 1/2" x 4"	Opt.	Opt.	Opt.	Opt.	Opt.	Opt.	Opt.	Opt.	Opt.	
	Carbon steel 1/2" x 6"	Opt.	Opt.	Opt.	Opt.	Opt.	Opt.	Opt.	Opt.	Opt.	
Adjustable skid shoes	Standard steel	Std.	Std.	Std.	Std.	Std.	Std.	Std.	Std.	Std.	
	CHT-360 steel	Opt.	Opt.	Opt.	Opt.	Opt.	Opt.	Opt.	Opt.	Opt.	
Full flight auger (industrial)	Opt.	Opt.	Opt.	Opt.	Opt.	Opt.	Opt.	Opt.	Opt.	Opt.	
Semi-industrial chute	Opt.	Opt.	Opt.	Opt.	Opt.	Opt.	Opt.	Opt.	Opt.	Opt.	
Industrial chute	Opt.	Opt.	Opt.	Opt.	Opt.	Opt.	Opt.	Opt.	Opt.	Opt.	
24" or 48" (61-122cm) chute extension	Opt.	Opt.	Opt.	Opt.	Opt.	Opt.	Opt.	Opt.	Opt.	Opt.	
Hydraulic telescopic industrial chute	-	-	-	-	-	-	-	-	-	-	
Deflector manual or hydraulic	Disp.	Disp.	Disp.	Disp.	Disp.	Disp.	Disp.	Disp.	Disp.	Disp.	
Bearing / ductile iron casting	Std.	Std.	Std.	Std.	Std.	Std.	Std.	Std.	Std.	Std.	
Lateral blades	Opt.	Opt.	Opt.	Opt.	Opt.	Opt.	Opt.	Opt.	Opt.	Opt.	
P.T.O. (standard)	No. 5	No. 5	No. 5	No. 5	No. 6	No. 6	No. 6	No. 6	No. 6	No. 6	
P.T.O. (optionnal)	-	-	-	-	-	-	-	-	-	-	
Weight (approx.)	(lbs)	1160	1330	1202	1372	1259	1432	1309	1482	1440	1609
	(kg)	522	599	541	617	567	644	590	674	648	724

Design and specifications subject to change without notice.

SNOWBLOWERS P-740 P-800 P-860 P-860-92

170-02473

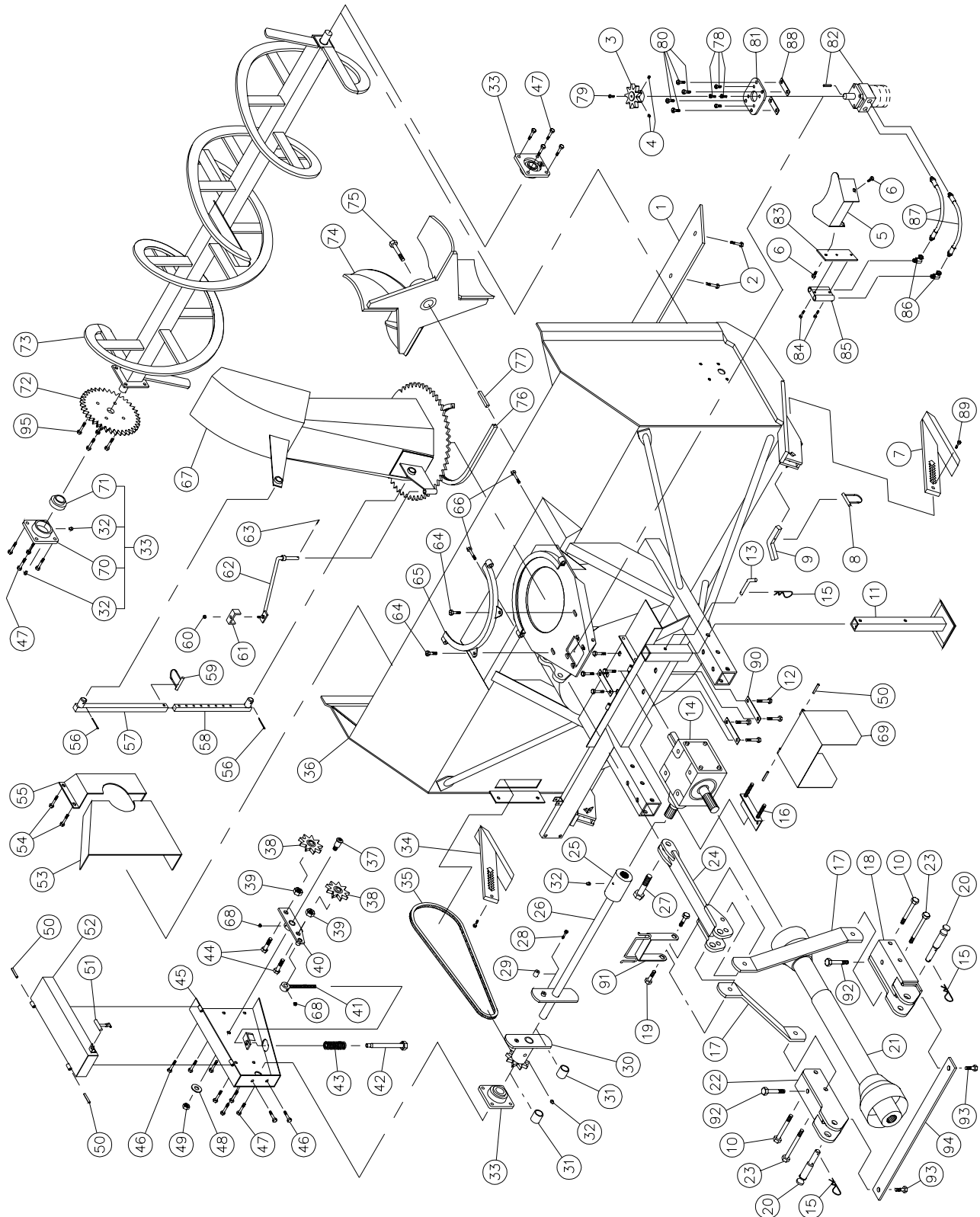

SNOWBLOWERS P-740 P-800 P-860 P-860-92 (cont'd)

REF.	PART #	DESCRIPTION	QTY			
			P-740	P-800	P-860	P-860-92
1	140-00921	Reversible scraper blade 3/8" x 4" x 67½" lg	1	-	-	-
1	140-00931	Reversible scraper blade 3/8" x 4" x 73½" lg	-	1	-	-
1	140-00911	Reversible scraper blade 3/8" x 4" x 79½" lg	-	-	1	-
1	140-09491	Couteau réversible 3/8" x 4" x 85 1/2" lg	-	-	-	1
2	125-0715	Plow bolt 7/16" x 1½" lg + nut & lock washer	7	8	8	9
3	110-04182	Sprocket 9 tooth	1	1	1	1
4	Std.	Hexagonal socket set screw 3/8" NC x 3/8" lg (2)	2	2	2	2
5	130-08161	Guard	1	1	1	1
6	Std.	Boulon 7/16" NC x 1 1/4" lg + nylon locknut + flat washer (2)	2	2	2	2
7	110-05491	Skid shoe (right side)	1	1	1	1
8	8112	Lock pin 1/4"	2	2	2	2
9	140-01861	Skid shoes lock	2	2	2	2
10	Std.	Bolt 5/8" NC x 5" lg + nylon lock nut	2	2	2	2
11	8219	Storage support	1	1	1	1
12	Std.	Bolt ½" NC x 1" lg +lock washer	8	8	8	8
13	8220	Storage support pin	1	1	1	1
14	8251	Gear box T27D	1	1	1	1
15	Std.	Hitch pin clip 5/32"	3	3	3	3
16	8199	Adjustment plate for gear box + 4 nuts 1/2" NC	1	1	1	1
17	140-10881	3-points side bar	2	2	-	-
17	140-10751	3-points side bar	-	-	2	2
18	110-15052	Right lower hitch	1	1	1	1
19	Std.	Bolt 5/8" NC x 2 1/4" lg + nylon lock nut	2	2	2	2
20	8004	Pin category 1 & 2	2	2	2	2
21	8114-EG	P.T.O. shaft T50	1	1	-	-
21	8202	P.T.O. shaft T60	opt.	opt.	-	-
21	9225-1	P.T.O. shaft T80	-	-	opt.	opt.
22	110-15051	Left lower hitch	1	1	1	1
23	Std.	Bolt 5/8" NC x 5½" lg + nylon lock nut	2	2	2	2
24	110-15091	Upper hitch	1	1	1	1
25	6466	Splined adaptor 1 ¼"-19 (welded)	1	1	1	1
26	110-05631	Auger drive shaft 26 7/16" lg overall (includes no. 25 and 29)	1	-	-	-
26	110-05641	Auger drive shaft 29 7/16" lg overall (includes no. 25 and 29)	-	1	-	-
26	110-05651	Auger drive shaft 32 7/16" lg overall (includes no. 25 and 29)	-	-	1	-
26	110-13171	Auger drive shaft 35 7/16" lg overall (includes no. 25 and 29)	-	-	-	1
27	Std.	Bolt 1" NC x 3" lg + nylon lock nut	1	1	1	1
28	Std.	Bolt 1/4" NC x 2" lg grade 5 + nylon lock nut	1	1	1	1
29	150-01491	Bushing ¼" i.d. x 7/8" o.d. x ¾" lg (welded)	2	2	2	2
30	8184	Sprocket #80 + shearplate (includes no. 31)	1	1	1	1
31	8009	Brass bushing 1 ¼" i.d. x 1 ½" o.d. x 1 3/16" lg	2	2	2	2
32	Std.	Grease fitting ¼"-28 straight	8	8	8	8
33	UCFLD207-20	Bearing 1 ¼" + flange & 2 grease fitting (straight)	3	3	3	3
34	110-03151	Skid shoe (left side)	1	1	1	1
35	190-01441	Chain #80 x 77" lg (77 links)	1	1	1	1
35	26A80	Connecting link #80	1	1	1	1
35	59-80	Offset link	1	1	1	1
36	120-03311	Frame P-740	1	-	-	-
36	120-03351	Frame P-800	-	1	-	-
36	120-03231	Frame P-860	-	-	1	-
36	120-03411	Frame P-860-92	-	-	-	1
37	150-00381	Idler clevis pin	1	1	1	1
38	9287	Idler sprocket #80 (steel)	2	2	2	2
39	Std.	Nut 7/8" NC	2	2	2	2
40	110-01211	Idler	1	1	1	1
41	110-01232	Threaded rod for idler adjustment + nut 7/16" NC	1	1	1	1
42	110-01221	Threaded tube for idler adjustment	1	1	1	1
43	9473	Compression spring	1	1	1	1

SNOWBLOWERS P-740 P-800 P-860 P-860-92 (cont'd)

REF.	PART #	DESCRIPTION	QTY			
			P-740	P-800	P-860	P-860-92
44	Std.	Bolt 3/4" NC x 2 1/2" lg + nylon locknut	2	2	2	2
45	110-11732	Chain guard	1	1	1	1
46	Std.	Bolt 7/16" NC x 1" lg + nylon lock nut	5	5	5	5
47	Std.	Bolt 7/16" NC x 1 1/2" lg + nylon lock nut	12	12	12	12
48	Std.	Flat washer 5/8"	1	1	1	1
49	346-44500	Nylon locknut 5/8" NC thin	1	1	1	1
50	Std.	Roll pin 5/16" x 2" lg	4	4	4	4
51	8125	Rubber fastener	1	1	1	1
52	110-11671	Chain guard cover	1	1	1	1
53	130-02001	Inside guard (welded)	1	1	1	1
54	Std.	Bolt 3/8" NC x 1" lg + nylon lock nut & flat washer	4	4	4	4
55	8018	Inside guard (bolted)	1	1	1	1
56	Std.	2 hairpin cotter 5/32" x 2" lg	opt.	opt.	opt.	opt.
57	8146	Chute adjusting tube	opt.	opt.	opt.	opt.
58	8145	Chute adjusting rod	opt.	opt.	opt.	opt.
59	8112	Lock pin 1/4"	opt.	opt.	opt.	opt.
60	Std.	Nylon locknut 5/16" NC	opt.	opt.	opt.	opt.
61	140-00881	Hoses mounting plate	opt.	opt.	opt.	opt.
62	110-01111	Mounting support plate	opt.	opt.	opt.	opt.
63	Std.	Cotter pin 1/8" x 1"	opt.	opt.	opt.	opt.
64	Std.	Bolt 1/2" NC x 1 1/2" lg + nylon locknut & flat washer	2	2	2	2
65	110-01341	Retaining bracket	1	1	1	1
66	Std.	Bolt 7/16" NC x 3" lg + nylon locknut	2	2	2	2
67	120-00731	Chute	opt.	opt.	opt.	opt.
68	Std.	Grease fitting 1/4" - 28 90 deg.	2	2	2	2
69	110-12421	Hinged P.T.O. shroud	1	1	1	1
70	FD207	Flange for grease fitting	3	3	3	3
71	UC207-20	Bearing 1 1/4"	3	3	3	3
72	8185	Sprocket 80A30 T 1 1/4" ø	1	1	1	1
73	8023	Auger P-740	1	-	-	-
73	8024	Auger P-800	-	1	-	-
73	8025	Auger P-860	-	-	1	-
73	110-13201	Auger P-860-92	-	-	-	1
74	110-01872	Impeller 26" ø 4 blades	1	1	-	-
74	110-01882	Impeller 28" ø 4 blades	-	-	1	1
75	Std.	Impeller cap screw 5/8" NC x 1 1/2" (ass. with lock-tite 242) + lock washer	1	1	1	1
76	8149	U-shaped UHMW ± 14" i. d.	1	1	1	1
77	8030	Square key 3/8" x 3/8" x 3 1/2" lg	1	1	1	1
78	Std.	Bolt 3/8" NC x 1" lg + rondelle de blocage (4)	4	4	4	4
79	Std.	Bolt 1/4" NC x 3/4" lg + lock washer	1	1	1	1
80	Std.	Bolt 7/16" NC x 1 1/2" lg + nylon locknut & flat washer (4)	4	4	4	4
81	130-08151	Orbit motor support	1	1	1	1
82	---	Hydraulic orbit motor	opt.	opt.	opt.	opt.
83	130-06291	Support plate for relief valve	opt.	opt.	opt.	opt.
84	Std.	Bolt 5/16" NC x 2 1/2" lg + nylon locknut (2)	opt.	opt.	opt.	opt.
85	DXV50	Relief valve	opt.	opt.	opt.	opt.
86	9405x8x8	Fitting 90 deg. swivel (2)	opt.	opt.	opt.	opt.
87	190-00421	Hose 3/8" x 16" lg + 2 fittings 6U108 (2)	opt.	opt.	opt.	opt.
88	140-09571	Spacer 1/8" x 1" x 3 1/4" lg for "Orbit" motor	2	2	2	2
89	Std.	Boulon 1/4" NC x 1 1/4" lg + nylon locknut	2	2	2	2
90	140-10571	Back plate	3	3	3	3
91	110-15291	Hoses support	1	1	1	1
92	Std.	Bolt 5/8" NC x 4 1/2" lg + nylon locknut	2	2	2	2
93	Std.	Bolt 1/2" NC x 1 1/2" lg + nylon locknut	2	2	2	2
94	140-10861	Brace	1	1	-	-
94	140-10871	Brace	-	-	1	1
95	Std.	Bolt 7/16" NC x 1 1/2" lg + two-way locknut	4	4	4	4

SNOWBLOWERS P-740TRC P-800TRC P-860TRC P-860TRC-92

170-02483

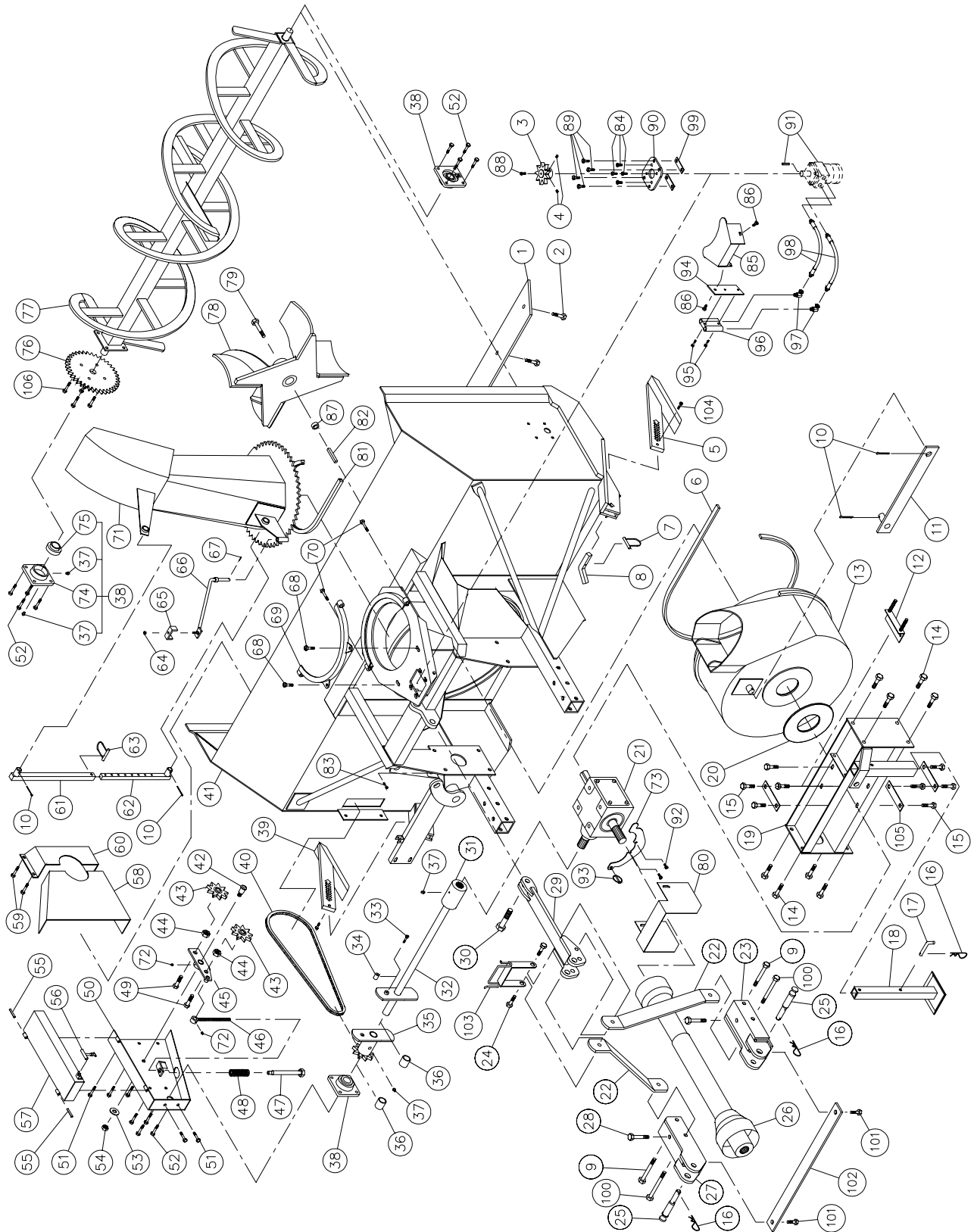

SNOWBLOWERS P-740TRC P-800TRC P-860TRC P-860TRC-92 (cont'd)

REF.	PART #	DESCRIPTION	QTY			
			P-740TRC	P-800TRC	P-860TRC	P-860TRC-92
1	140-00921	Reversible scraper blade 3/8" x 4" x 67½" lg	1	-	-	-
1	140-00931	Reversible scraper blade 3/8" x 4" x 73½" lg	-	1	-	-
1	140-00911	Reversible scraper blade 3/8" x 4" x 79½" lg	-	-	1	-
1	140-09491	Reversible scraper blade 3/8" x 4" x 85½" lg	-	-	-	1
2	125-0715	Plow bolt 7/16" NC x 1 ½" lg + nut & lock washer	7	8	8	9
3	110-04182	Sprocket 9 tooth	1	1	1	1
4	Std.	Hexagonal socket set screw 3/8" NC x 3/8" lg (2)	2	2	2	2
5	110-05491	Skid shoe (right side)	1	1	1	1
6	8195	U-shaped UHMW 3/8" x 7/8" x 84 5/8" lg	1	1	-	-
6	8196	U-shaped UHMW 3/8" x 7/8" x 91" lg	-	-	1	1
7	8112	Lock pin 1/4"	2	2	2	2
8	140-01861	Skid shoes lock	2	2	2	2
9	Std.	Bolt 5/8" NC x 5" lg + nylon lock nut	2	2	2	2
10	Std.	Cotter pin 5/32" x 2" lg	4	4	4	4
11	8037	Connecting rod ½" x 2" x 21" lg	1	1	-	-
11	8229	Connecting rod ½" x 2" x 22" lg	-	-	1	1
12	8199	Adjustment plate for gear box + 4 nuts ½" NC	1	1	1	1
13	110-12441	Rotary drum 26" ø	1	1	-	-
13	110-12431	Rotary drum 28" ø	-	-	1	1
14	Std.	Bolt 5/8" NC x 1 ½" lg + nylon lock nut	8	8	8	8
15	Std.	Bolt ½" NC x 1" lg + lockwasher	8	8	8	8
16	Std.	Hitch pin clip 5/32"	3	3	3	3
17	8220	Storage support pin	1	1	1	1
18	8219	Storage support	1	1	1	1
19	8230	Gear box support	1	1	-	-
19	8231	Gear box support	-	-	1	1
20	8232	UHMW flat washer 3/16" x 4 5/8" i.d. x 8 1/8" o.d.	1	1	1	1
21	8251	Gear box T-27D	1	1	1	1
22	140-10751	3-points side bar	2	2	-	-
22	140-10691	3-points side bar	-	-	2	2
23	110-15052	Right lower hitch	1	1	1	1
24	Std.	Bolt 5/8" NC x 2 1/4" lg + nylon lock nut	2	2	2	2
25	8004	Pin category 1 & 2	2	2	2	2
26	8114-EG	P.T.O. shaft T50	1	1	-	-
26	8202	P.T.O. shaft T60	opt.	opt.	1	1
26	9225-1	P.T.O. shaft T80	-	-	opt.	opt.
27	110-15051	Left lower hitch	1	1	1	1
28	Std.	Bolt 5/8" NC x 4 1/2" lg + nylon lock nut	2	2	2	2
29	110-15071	Upper hitch	1	1	1	1
30	Std.	Bolt 1" NC x 3" lg + nylon lock nut	1	1	1	1
31	6466	Splined adaptor 1 ¼" - 19 (welded)	1	1	1	1
32	110-05631	Auger drive shaft 26 7/16" lg overall (includes no. 31 and 34)	1	-	-	-
32	110-05641	Auger drive shaft 29 7/16" lg overall (includes no. 31 and 34)	-	1	-	-
32	110-05651	Auger drive shaft 32 7/16" lg overall (includes no. 31 and 34)	-	-	1	-
32	110-13171	Auger drive shaft 35 7/16" lg overall (includes no. 31 and 34)	-	-	-	1
33	Std.	Bolt 1/4" NC x 2" lg grade 5 + nylon lock nut	1	1	1	1
34	150-01491	Bushing 1/4" i.d. x 7/8" o.d. x 3/4" lg (welded)	2	2	2	2
35	8184	Sprocket #80 + shearplate (includes no. 36)	1	1	1	1
36	8009	Bushing 1 1/4" i.d. x 1 1/2" o.d. x 1 3/16" lg	2	2	2	2
37	Std.	Grease fitting 1/4"-28 straight	8	8	8	8
38	UCFLD207-20	Bearing 1 1/4" + flange & 2 grease fitting (straight)	3	3	3	3
39	110-03151	Skid shoe (left side)	1	1	1	1
40	190-01441	Chain #80 x 77" lg (77 links)	1	1	1	1
40	26A80	Connecting link #80	1	1	1	1
40	59-80	Offset link #80	1	1	1	1

SNOWBLOWERS P-740TRC P-800TRC P-860TRC P-860TRC-92 (cont'd)

REF.	PART #	DESCRIPTION	QTY			
			P-740TRC	P-800TRC	P-860TRC	P-860TRC-92
41	120-03331	Frame P-740TRC	1	-	-	-
41	120-03371	Frame P-800TRC	-	1	-	-
41	120-03251	Frame P-860TRC	-	-	1	-
41	120-03391	Frame P-860-92TRC	-	-	-	1
42	150-00381	Idler clevis pin	1	1	1	1
43	9287	Idler sprocket #80	2	2	2	2
44	Std.	Nut 7/8" NC	2	2	2	2
45	110-01211	Idler	1	1	1	1
46	110-01232	Threaded rod for idler adjustment + nut 7/16" NC	1	1	1	1
47	110-01221	Threaded tube for idler adjustment	1	1	1	1
48	9473	Compression spring	1	1	1	1
49	Std.	Bolt 3/4" NC x 2 1/2" lg + nylon locknut	2	2	2	2
50	110-11732	Chain guard	1	1	1	1
51	Std.	Bolt 7/16" NC x 1" lg + nylon lock nut	5	5	5	5
52	Std.	Bolt 7/16" NC x 1 1/2" lg + nylon lock nut	12	12	12	12
53	Std.	Flat washer 5/8"	1	1	1	1
54	346-44500	Nylon locknut 5/8" NC thin	1	1	1	1
55	Std.	Roll pin 5/16" x 2" lg	2	2	2	2
56	8125	Rubber fastener	1	1	1	1
57	110-11671	Chain guard cover	1	1	1	1
58	130-02001	Inside guard (welded)	1	1	1	1
59	Std.	Bolt 3/8" NC x 1" lg + nylon locknut & flat washer	4	4	4	4
60	8018	Inside guard (bolted)	1	1	1	1
61	8146	Chute adjusting tube	opt.	opt.	opt.	opt.
62	8145	Chute adjusting rod	opt.	opt.	opt.	opt.
63	8112	Lock pin 1/4"	opt.	opt.	opt.	opt.
64	Std.	Nylon locknut 5/16" NC	opt.	opt.	opt.	opt.
65	140-00881	Hoses mounting plate	opt.	opt.	opt.	opt.
66	110-01111	Mounting support plate	opt.	opt.	opt.	opt.
67	Std.	Cotter pin 1/8" x 1"	opt.	opt.	opt.	opt.
68	Std.	Bolt 1/2" NC x 1 1/2" lg + nylon locknut & flat washer	2	2	2	2
69	110-01341	Retaining bracket	1	1	1	1
70	Std.	Bolt 7/16" NC x 3" lg + nylon locknut	2	2	2	2
71	110-00731	Chute	opt.	opt.	opt.	opt.
72	Std.	Grease fitting 1/4" - 28 90 deg.	2	2	2	2
73	130-14151	Guard mounting plate	1	1	1	1
74	FD207	Flange for 2 grease fitting	3	3	3	3
75	UC207-20	Bearing 1 1/4"	3	3	3	3
76	8185	Sprocket 80A30 T 1 1/4" ø	1	1	1	1
77	8023	Auger P-740	1	-	-	-
77	8024	Auger P-800	-	1	-	-
77	8025	Auger P-860	-	-	1	-
77	110-13201	Auger P-860-92	-	-	-	1
78	110-01872	Impeller 26" ø 4 blades	1	1	-	-
78	110-01882	Impeller 28" ø 4 blades	-	-	1	1
79	Std.	Impeller cap screw 5/8" NC x 2" lg (ass. with lock-tite 242) + lock washer	1	1	1	1
80	130-14141	Hinged P.T.O. shroud	1	1	1	1
81	8149	U-shaped UHMW ± 14" i. d.	1	1	1	1
82	8030	Square key 3/8" x 3/8" x 3 1/2" lg	1	1	1	1
83	Std.	Rotary drum safety shear bolt 3/8" NC x 2" lg + nylon locknut	1	1	1	1
84	Std.	Bolt 3/8" NC x 1" lg + lock washer	4	4	4	4
85	130-08161	Guard	1	1	1	1
86	Std.	Bolt 7/16" NC x 1 1/4" lg + nylon locknut & flat washer	2	2	2	2
87	8298	Spacer 3/4" i.d. x 1 1/4" o.d. x 9/16" lg	1	1	1	1
88	Std.	Bolt 1/4" NC x 3/4" lg + lock washer	1	1	1	1

SNOWBLOWERS P-740TRC P-800TRC P-860TRC (cont'd)

REF.	PART #	DESCRIPTION	QTY			
			P-740TRC	P-800TRC	P-860TRC	P-860TRC-92
89	Std.	Bolt 7/16" NC x 1 1/2" lg + nylon locknut & flat washer (4)	4	4	4	4
90	130-08151	Orbit motor support	1	1	1	1
91	---	Hydraulic orbit motor	opt.	opt.	opt.	opt.
92	Std.	Bolt M8 x 1.25 x 16 mm lg + lock washer	2	2	2	2
93	Std.	Linch pin	1	1	1	1
94	130-06291	Support plate for relief valve	opt.	opt.	opt.	opt.
95	Std.	Bolt 5/16" NC x 2 1/2" lg + nylon locknut (2)	opt.	opt.	opt.	opt.
96	DXV50	Relief valve	opt.	opt.	opt.	opt.
97	9405x8x8	Fitting 90 deg. swivel (2)	opt.	opt.	opt.	opt.
98	190-00421	Hose 3/8" x 16" lg + 2 fittings 6U108 (2)	opt.	opt.	opt.	opt.
99	140-09571	Spacer 1/8" x 1" x 3 1/4" lg for "Orbit" motor	2	2	2	2
100	Std.	Bolt 5/8" NC x 5 1/2" lg + nylon locknut	2	2	2	2
101	Std.	Bolt 1/2" NC x 1 1/2" lg + nylon locknut	2	2	2	2
102	140-10851	Brace 3/8" x 1 1/2" x 32 3/16" lg	1	1	-	-
102	140-10651	Brace 3/8" x 1 1/2" x 34 3/16" lg	-	-	1	1
103	110-15291	Hoses support	1	1	1	1
104	Std.	Bolt 1/4" NC x 1 1/4" lg + nylon locknut	2	2	2	2
105	140-10571	Back plate	3	3	3	3
106	Std.	Bolt 7/16" NC x 1 1/2" lg + two-way locknut	4	4	4	4

SNOWBLOWER P-862

170-02493

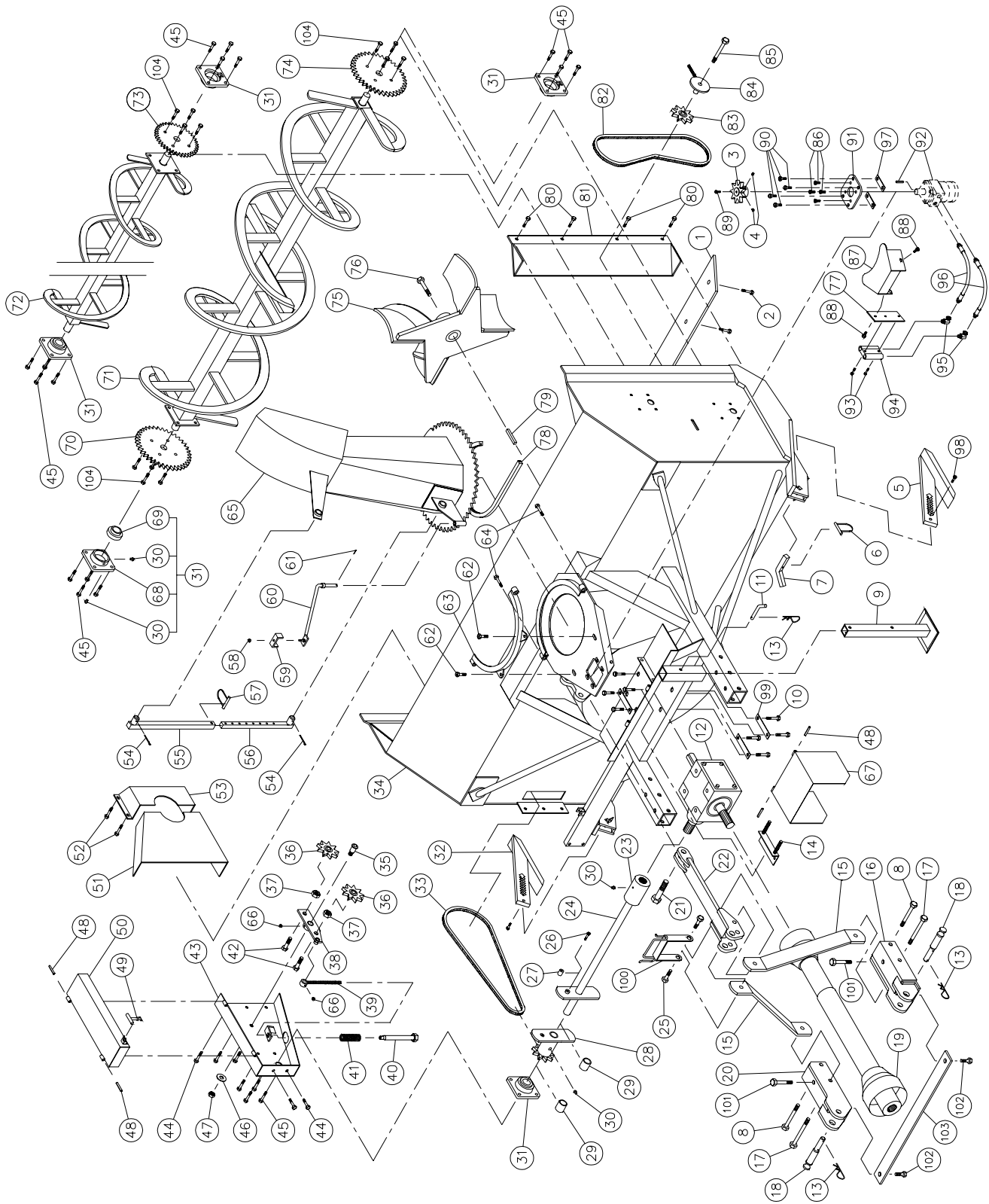

SNOWBLOWER P-862 (cont'd)

REF.	PART #	DESCRIPTION	QTY
1	140-00911	Reversible scraper blade 3/8" x 4" x 79½" lg.....	1
2	125-0715	Plow bolt 7/16" NC x 1½" lg + nut & lock washer	8
3	110-04182	Sprocket 9 tooth	1
4	Std.	Hexagonal socket set screw 3/8" NC x 3/8" lg (2)	2
5	110-05491	Skid shoe (right side).....	1
6	8112	Lock pin 1/4"	2
7	140-01861	Skid shoes lock	2
8	Std.	Bolt 5/8" NC x 5" lg + nylon locknut	2
9	8219	Storage support	1
10	Std.	Bolt ½" NC x 1" lg + lock washer	8
11	8220	Storage support pin	1
12	8251	Gear box	1
13	Std.	Hitch pin clip 5/32"	3
14	110-05321	Adjustment plate for gear box + 4 nuts 1/2" NC	1
15	140-10751	3-points side bar	2
16	110-15052	Right lower hitch	1
17	Std.	Bolt 5/8" NC x 5 1/2" lg + nylon locknut	2
18	8004	Pin category 1 & 2	2
19	8202	P.T.O. shaft T60	1
19	9225-1	P.T.O. shaft T80	opt.
20	110-15051	Left lower hitch	1
21	Std.	Bolt 1" NC x 3" lg + nylon locknut	1
22	110-15091	Upper hitch	1
23	6466	Splined adaptor 1¼" - 19 splines (welded).....	1
24	110-05651	Auger drive shaft 32 7/16" lg overall (includes no. 23 and 27)	1
25	Std.	Bolt 5/8" NC x 2 1/4" lg + nylon locknut	2
26	Std.	Bolt 1/4" NC x 2" lg grade 5 + nylon locknut	1
27	150-01491	Bushing ¼" i.d. x 7/8" o.d. x ¾" lg (welded)	2
28	8184	Sprocket #80 + shearplate (includes no. 29)	1
29	8009	Brass bushing 1¼" i.d. x 1½" o.d. x 1 3/16" lg	2
30	Std.	Grease fitting ¼"-28 straight	12
31	UCFLD207-20	Bearing 1¼" + flange & 2 grease fitting (straight)	5
32	110-03151	Skid shoe (left side)	1
33	190-01441	Chain # 80 x 77" lg (77 links)	1
33	26A80	Connecting link #80	1
33	59-80	Offset link #80	1
34	120-03271	Frame P-862	1
35	150-00381	Idler clevis pin	1
36	9287	Idler sprocket #80	2
37	Std.	Nut 7/8" NC	2
38	110-01211	Idler	1
39	110-01232	Threaded rod for idler adjustment + nut 7/16" NC	1
40	110-01221	Threaded tube for idler adjustment	1
41	9473	Compression spring.....	1
42	Std.	Bolt 3/4" NC x 2 1/2" lg + nylon locknut	2
43	110-11732	Chain guard	1
44	Std.	Bolt 7/16" NC x 1" lg + nylon locknut	5
45	Std.	Bolt 7/16" NC x 1½" lg + nylon locknut	20
46	Std.	Flat washer 5/8"	1
47	346-44500	Nylon locknut 5/8" NC thin	1
48	Std.	Roll pin 5/16" x 2" lg	4
49	8125	Rubber fastener	1
50	110-11671	Chain guard cover.....	1

SNOWBLOWER P-862 (cont'd)

REF.	PART #	DESCRIPTION	QTY
51	130-02001	Inside guard (welded)	1
52	Std.	Bolt 3/8" NC x 1" lg + nylon locknut & flat washer	4
53	8018	Inside guard (bolted)	1
54	Std.	2 hairpin cotter 5/32" x 2" lg	opt.
55	8146	Chute adjusting tube	opt.
56	8145	Chute adjusting rod	opt.
57	8112	Lock pin 1/4"	opt.
58	Std.	Nylon locknut 5/16"	opt.
59	140-00881	Hoses mounting plate	opt.
60	110-01111	Mounting support plate	opt.
61	Std.	Cotter pin 1/8" x 1"	opt.
62	Std.	Bolt 1/2" NC x 1 1/2" lg + nylon locknut & flat washer	2
63	110-01341	Retaining bracket	1
64	Std.	Bolt 7/16" NC x 3"lg + nylon locknut	2
65	120-00731	Chute	opt.
66	Std.	Grease fitting 1/4" - 28 90 deg.	2
67	110-12421	Hinged P.T.O. shroud	1
68	FD207	Flange for 2 grease fitting	5
69	UC207-20	Bearing 1 1/4"	5
70	8185	Sprocket 80A30 T 1 1/4" ø	1
71	8139	Lower auger P-862	1
72	8134	Upper auger P-862	1
73	8144	Sprocket 60A30 T 1 1/4" ø	1
74	8021	Sprocket 60A38 T 1 1/4" ø	1
75	110-01882	Impeller 28" ø 4 blades	1
76	Std.	Impeller cap screw 5/8" NC x 1 1/2" lg (ass. with lock-tite 242) + lock washer	1
77	130-06291	Support plate for relief valve	opt.
78	8149	U-shaped UHMW ± 14" i. d.	1
79	8030	Square key 3/8" x 3/8" x 3 1/2" lg	1
80	Std.	Bolt 7/16" NC x 1" lg + nylon locknut	4
81	8135	Drive chain guard (upper auger)	1
82	190-01301	Chain #60 x 63 3/4" lg	1
83	8186	Idler sprocket #60	1
84	8136	Idler for upper auger (hole 1/2") + 2 nuts 1/2" NC	1
85	Std.	Bolt 1/2" NC x 3 1/2" lg + nylon locknut & flat washer	1
86	Std.	Bolt 3/8" NC x 1" lg + lock washer (4)	4
87	130-08161	Guard	1
88	Std.	Bolt 7/16" NC x 1 1/4" lg + nylon locknut + flat washer	2
89	Std.	Bolt 1/4" NC x 3/4" lg + lock washer	1
90	Std.	Bolt 7/16" NC x 1 1/2" lg + nylon locknut & flat washer	4
91	130-08151	Orbit motor support	1
92	---	Hydraulic orbit motor	opt.
93	Std.	Bolt 5/16" NC x 2 1/2" lg + nylon locknut (2)	opt.
94	DXV50	Relief valve	opt.
95	9405x8x8	Fitting 90 deg. swivel (2)	opt.
96	190-00421	Hose 3/8" x 16" lg + 2 fittings 6U108 (2)	opt.
97	140-09571	Spacer 1/8" x 1" x 3 1/4" lg for "Orbit" motor	2
98	Std.	Bolt 1/4" NC x 1 1/4" lg + nylon locknut	2
99	140-10571	Back plate	3
100	110-15291	Hoses support	1
101	Std.	Bolt 5/8" NC x 4 1/2" lg + nylon locknut	2
102	Std.	Bolt 1/2" NC x 1 1/2" lg + nylon locknut	2
103	140-10871	Brace 3/8" x 1 1/2" x 32 1/16" lg	1
104	Std.	Bolt 7/16" NC x 1 1/2" lg + two-way locknut	12

SNOWBLOWER P-862TRC

170-02503

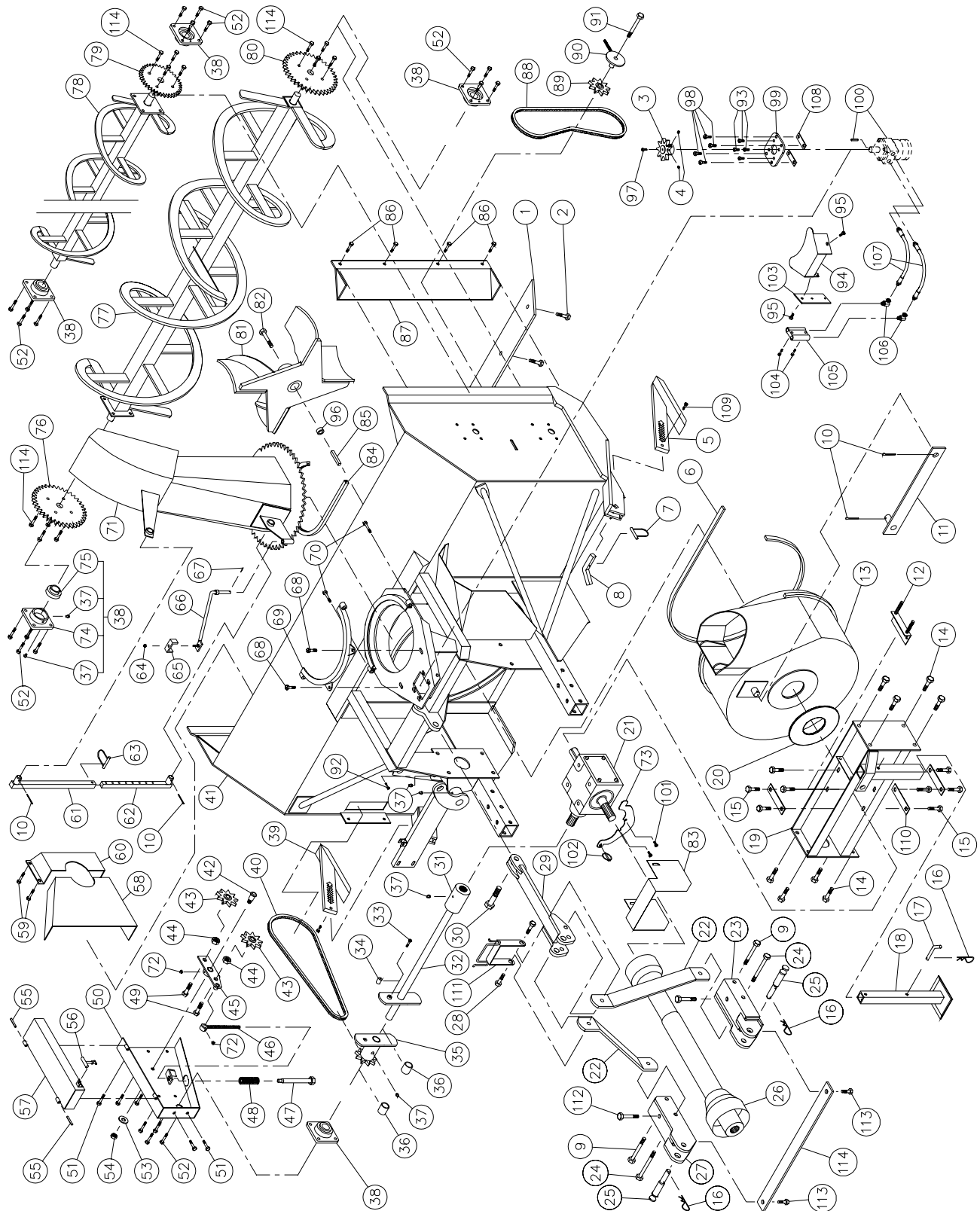

10

SNOWBLOWER P-862TRC (cont'd)

REF.	PART #	DESCRIPTION	QTY
1	140-00911	Reversible scraper blade 3/8" x 4" x 79½" lg	1
2	125-0715	Plow bolt 7/16" NC x 1½" lg + nut & lockwasher	8
3	110-04182	Sprocket 9 tooth	1
4	Std.	Hexagonal socket set screw 3/8" NC x 3/8" lg	2
5	110-05491	Skid shoe (right side)	1
6	8196	U-shaped UHMW 3/8" x 7/8" x 91" lg	1
7	8112	Lock pin 1/4"	2
8	140-01861	Skid shoes lock	2
9	Std.	Bolt 5/8" NC x 5" lg + nylon locknut	2
10	Std.	Hairpin cotter 5/32" x 2" lg	4
11	8229	Connecting rod ½" x 2" x 22" lg	1
12	110-05321	Adjustment plate for gear box + 4 nuts ½" NC	1
13	110-12431	Rotary drum 28" ø	1
14	Std.	Bolt 5/8" NC x 1½" lg + nylon locknut	8
15	Std.	Bolt ½" NC x 1" lg + lock washer	8
16	Std.	Hitch pin clip 5/32"	3
17	8220	Storage support pin	1
18	8219	Storage support	1
19	110-02121	Gear box support	1
20	8232	UHMW flat washer 3/16" x 4 5/8" i.d. x 8 1/8" o.d.	1
21	8251	Gear box	1
22	140-10691	3-points side bar	2
23	110-15052	Right lower hitch	1
24	Std.	Bolt 5/8" NC x 5 1/2" lg + nylon locknut	2
25	8004	Pin category 1 & 2	2
26	8202	P.T.O. shaft T60	1
26	9225-1	P.T.O. shaft T80	opt.
27	110-15051	Left lower hitch	1
28	Std.	Bolt 5/8" NC x 2 1/4" lg + nylon locknut	2
29	110-15071	Upper hitch	1
30	Std.	Bolt 1" NC x 3" lg + nylon locknut	1
31	6466	Splined adaptor 1¼"-19 (welded)	1
32	110-05651	Auger drive shaft 32 7/16" lg overall (includes no. 31 and 34)	1
33	Std.	Bolt 1/4" NC x 2" lg grade 5 + nylon locknut	1
34	150-01491	Bushing 1/4" i.d. x 7/8" o.d. x 3/4" lg (welded)	2
35	8184	Sprocket #80 + shearplate (includes no. 36)	1
36	8009	Brass bushing 1 1/4" i.d. x 1 1/2" o.d. x 1 3/16" lg	2
37	Std.	Grease fitting 1/4"-28 straight	14
38	UCFLD207-20	Bearing 1 1/4" + flange & 2 grease fitting (straight)	5
39	110-03151	Skid shoe (left side)	1
40	190-01441	Chain #80 x 77" lg (77 links)	1
40	26A80	Connecting link #80	1
40	59-80	Offset link #80	1
41	120-03291	Frame P-862TRC	1
42	150-00381	Idler clevis pin	1
43	9287	Idler sprocket #80	2
44	Std.	Nut 7/8" NC	2
45	110-01211	Idler	1
46	110-01232	Threaded rod for idler adjustment + nut 7/16" NC	1
47	110-01221	Threaded tube for idler adjustment	1
48	9473	Compression spring	1
49	Std.	Bolt 3/4" NC x 2 1/2" lg + nylon locknut	2
50	110-11732	Chain guard	1
51	Std.	Bolt 7/16" NC x 1" lg + nylon locknut	5
52	Std.	Bolt 7/16" NC x 1 1/2" lg + nylon locknut	20
53	Std.	Flat washer 5/8"	1

SNOWBLOWER P-862TRC (cont'd)

REF.	PART #	DESCRIPTION	QTY
54	346-44500	Nylon locknut 5/8" NC thin	1
55	Std.	Roll pin 5/16" x 2" lg	2
56	8125	Rubber fastener	1
57	110-11671	Chain guard cover	1
58	130-02001	Inside guard (welded)	1
59	Std.	Bolt 3/8" NC x 1" lg + nylon locknut & flat washer	4
60	8018	Inside guard (bolted)	1
61	8146	Chute adjusting tube	opt.
62	8145	Chute adjusting rod	opt.
63	8112	Lock pin 1/4"	opt.
64	Std.	Nylon locknut 5/16" NC	opt.
65	140-00881	Hoses mounting plate	opt.
66	110-01111	Mounting support plate	opt.
67	Std.	Cotter pin 1/8" x 1"	opt.
68	Std.	Bolt 1/2" NC x 1 1/2" lg + nylon locknut & flat washer	2
69	110-01341	Retaining bracket	1
70	Std.	Bolt 7/16" NC x 3"lg + nylon locknut	2
71	120-00731	Chute	opt.
72	Std.	Gease fitting 1/4" - 28 90 deg.	2
73	130-14151	Guard mounting plate	1
74	FD207	Flange for 2 grease fitting	5
75	UC207-20	Bearing 1 1/4"	5
76	8185	Sprocket 80A30 T 1 1/4" ø	1
77	8139	Lower auger P-862TRC	1
78	8134	Upper auger P-862TRC	1
79	8144	Sprocket 60A30 T 1 1/4" ø	1
80	8021	Sprocket 60A38 T 1 1/4" ø	1
81	110-01882	Impeller 28" ø 4 blades	1
82	Std.	Impeller cap screw 5/8" NC x 2" lg (ass. with lock-tite 242) + lock washer	1
83	130-14141	Hinged P.T.O. shroud	1
84	8149	U-shaped UHMW ± 14" i. d.	1
85	8030	Square key 3/8" x 3/8" x 3 1/2" lg	1
86	Std.	Bolt 7/16 NC x 1" lg + nylon locknut	4
87	8135	Drive chain guard (upper auger)	1
88	190-01301	Chain #60 x 63 3/4" lg (85 links)	1
89	8186	Idler sprocket #60	1
90	8136	Idler for upper auger (hole 1/2") + 2 nuts 1/2" NC	1
91	Std.	Bolts 1/2" NC x 3 1/2" lg + nylon locknut & flat washer	1
92	Std.	Rotary drum safety shear bolt 3/8" NC x 2 1/4" lg + nylon locknut	1
93	Std.	Bolt 3/8" NC x 1" lg + lock washer	4
94	130-08161	Guard	1
95	Std.	Bolt 7/16" NC x 1 1/4" lg + lock washer	2
96	8298	Spacer 3/4" i.d. x 1 1/4" o.d. x 9/16" lg	1
97	Std.	Bolt 1/4" NC x 3/4" lg + lock washer	1
98	Std.	Bolt 7/16" NC x 1 1/2" lg + nylon locknut & flat washer (4)	4
99	130-08151	Orbit motor support	1
100	---	Hydraulic orbit motor	opt.
101	Std.	Boulon Bolt M8 x 1.25 x 16 mm lg + lock washer	2
102	Std.	Linch pin 1/4" x 1 3/4" lg	1
103	130-06291	Support plate for relief valve	opt.
104	Std.	Bolt 5/16" NC x 2 1/2" lg + nylon locknut (2)	opt.
105	DXV50	Relief valve	opt.
106	9405x8x8	Fitting 90 deg. swivel (2)	opt.
107	190-00421	Hose 3/8" x 16" lg + 2 fittings 6U108 (2)	opt.
108	140-09571	Spacer 1/8" x 1" x 3 1/4" lg for "Orbit" motor	2
109	Std.	Bolt 1/4" NC x 1 1/4" lg + nylon locknut	2

SNOWBLOWER P-862TRC (cont'd)

REF.	PART #	DESCRIPTION	QTY
110	140-10571	Back plate	3
111	110-15291	Hoses support	1
112	Std.	Bolt 5/8" NC x 4 1/2" lg + nylon locknut	2
113	Std.	Bolt 1/2" NC x 1 1/2" lg + nylon locknut	2
114	140-10651	Brace 3/8" x 1 1/2" x 34 3/16" lg	1
115	Std.	Bolt 7/16" NC x 1 1/2" lg + two-way locknut	12

SEMI-INDUSTRIAL CHUTE PSI-7486

170-00592

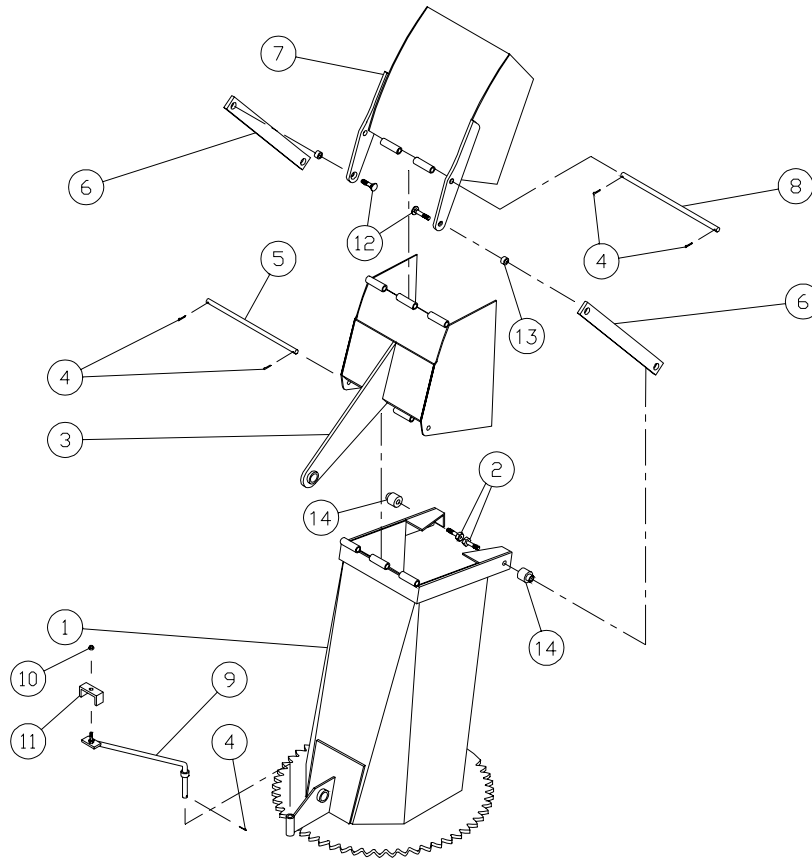

REF.	PART #	DESCRIPTION	QTY
1	110-04411	Chute base	1
2	Std.	Bolt ½" x 3" lg + nylon lock nut + flat washer	2
3	110-17881	Lower chute deflector	1
4	Std.	Cotter pin 1/8" x 1" lg	5
5	4551	Lower chute deflector pin	1
6	140-11681	Connecting rod	2
7	110-17851	Upper chute deflector	1
8	5318	Upper chute deflector pin	1
9	110-01111	Threaded rod for idler adjustment Hoses support	1
10	Std.	Nylon locknut 5/16" NC	1
11	140-00881	Hose hold down	1
12	Std.	Plow bolt 7/16" x 1 1/4" lg + nylon lock nut + flat washer	2
13	150-03831	Spacer for connecting rod (top)	2
14	150-03871	Spacer for connecting rod (bottom)	2

INDUSTRIAL CHUTE PC-7486

170-00602

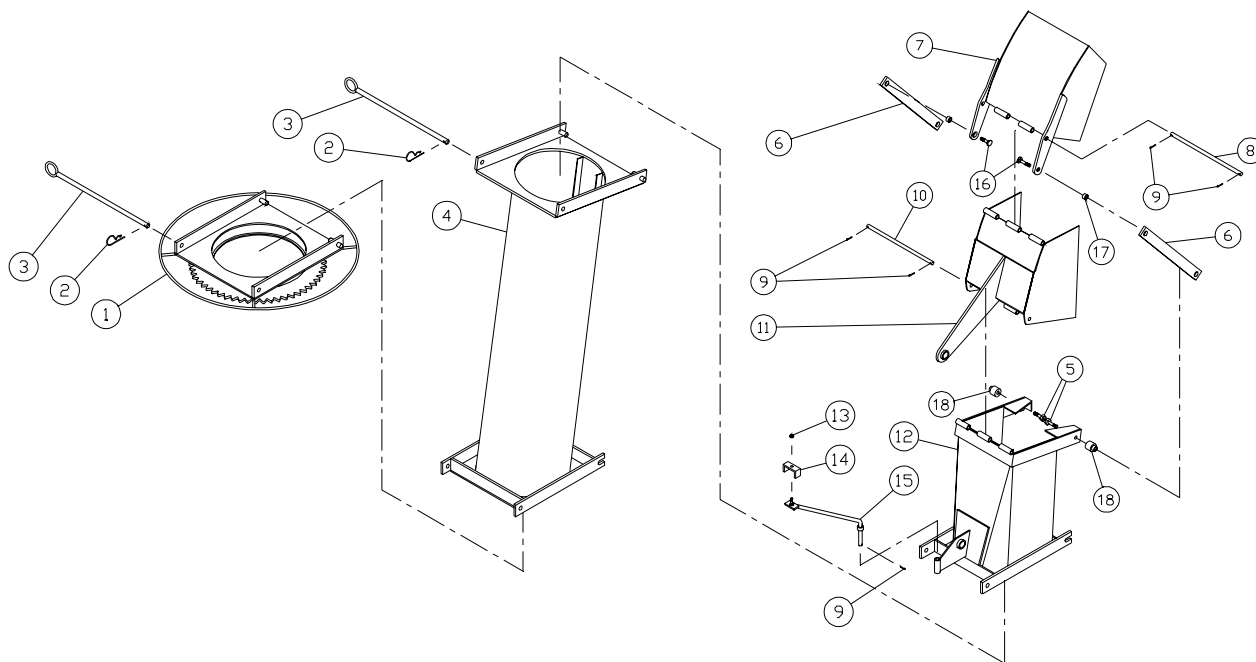

REF.	PART #	DESCRIPTION	QTY
1	110-04441	Chute adaptor with quick attach	1
2	Std.	Hitch pin clip 5/32"	2
3	8200	Pin for quick attach (adaptor & extension)	2
4	PR-7486	Extension 48" PR-7486	opt.
5	Std.	Bolt 1/2" NC x 3" lg + nylon lock nut & flat washer	2
6	140-11681	Connecting rod	2
7	110-17851	Upper deflector	1
8	5318	Upper deflector pin	1
9	Std.	Cotter pin 1/8" x 1" lg	5
10	4551	Lower deflector pin	1
11	110-17881	Lower deflector	1
12	110-08271	Chute base	1
13	Std.	Nylon locknut 5/16" NC	1
14	140-00881	Hoses mounting plate	1
15	110-01111	Mounting support plate	1
16	Std.	Plow bolt 7/16" x 1 1/4" lg + nylon locknut & flat washer	2
17	150-03831	Spacer for connecting rod (top)	2
18	150-03871	Spacer for connecting rod (bottom)	2
NI*	110-01812	"Industrial" chute assembly (includes # 5, 6, 7, 8, 9, 10, 11, 12, 16, 17, 18)	1

NI = NOT ILLUSTRATED

OPTIONS

170-02841

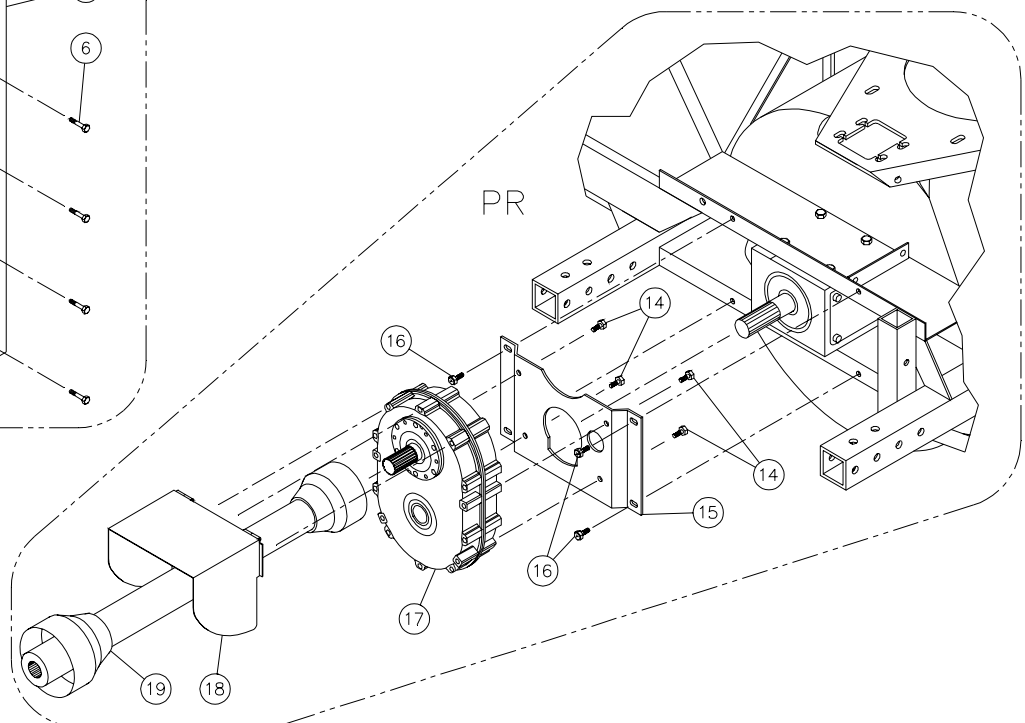
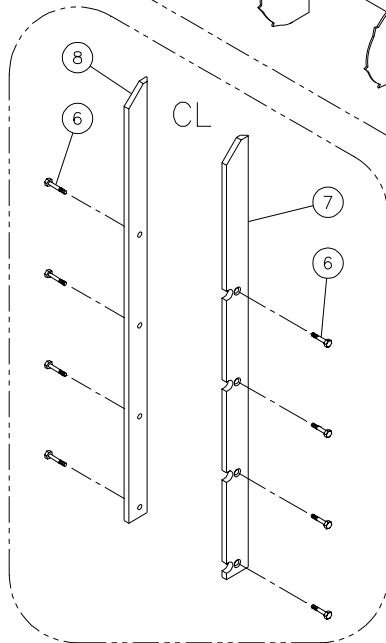
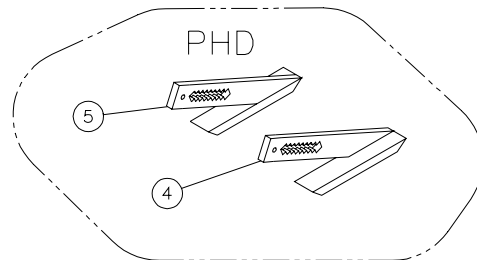
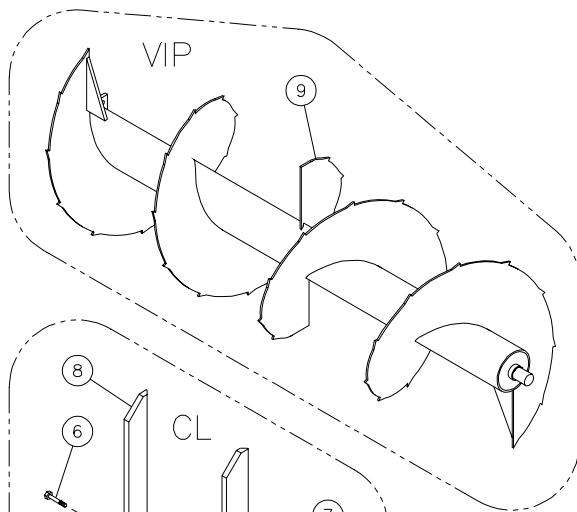
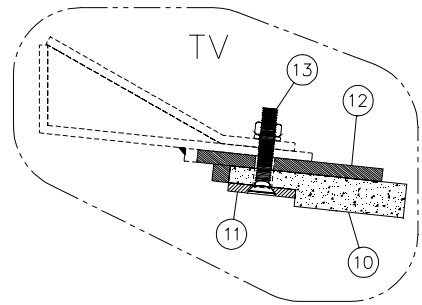
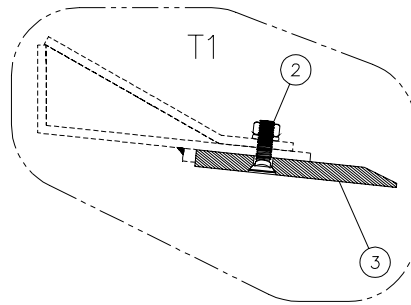
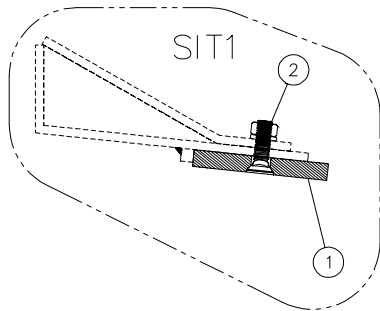

OPTIONS

REF.	PART #	DESCRIPTION	P-740	P-740 TRC	P-800	P-800 TRC	P-860	P-860 TRC	P-862	P-862 TRC
1	140-04051	Scraper blade (hard. steel, not sharpened, reversible) 1/2" x 4" x 67½"	1	1	-	-	-	-	-	-
1	140-04061	Scraper blade (hard. steel, not sharpened, reversible) 1/2" x 4" x 73½"	-	-	1	1	-	-	-	-
1	140-04071	Scraper blade (hard. steel, not sharpened, reversible) 1/2" x 4" x 79½"	-	-	-	-	1	1	1	1
2	319-38310	Plow bolt 7/16" NC x 1½" lg + nut & lock washer	7	7	8	8	8	8	8	8
3	140-04111	Scraper blade (hardened steel, sharpened, not reversible) 1/2" x 6" x 67½"	1	1	-	-	-	-	-	-
3	140-04121	Scraper blade (hardened steel, sharpened, not reversible) 1/2" x 6" x 73½"	-	-	1	1	-	-	-	-
3	140-04131	Scraper blade (hardened steel, sharpened, not reversible) 1/2" x 6" x 79½"	-	-	-	-	1	1	1	1
4	110-05501	Carbon steel skid shoe (right side)	1	1	1	1	1	1	1	1
5	110-04681	Carbon steel skid shoe (left side)	1	1	1	1	1	1	1	1
6	319-38310	Plow bolt 7/16" NC x 1½" lg + nut & lock washer	8	8	8	8	8	8	8	8
7	130-08291	Lateral blade (right side)	1	1	1	1	1	1	-	-
7	130-08301	Lateral blade (right side)	-	-	-	-	-	-	1	1
8	130-08292	Lateral blade (left side)	1	1	1	1	1	1	-	-
8	130-19271	Lateral blade (left side)	-	-	-	-	-	-	1	1
9	110-13901	Full flight spiked auger	1	1	-	-	-	-	-	-
9	110-13911	Full flight spiked auger	-	-	1	1	-	-	-	-
9	110-13921	Full flight spiked auger	-	-	-	-	1	1	1	1
10	190-03431	Scraper blade, TIVAR not reversible 1" x 5 1/4" x 67 1/2"	1	1	-	-	-	-	-	-
10	190-03501	Scraper blade, TIVAR not reversible 1" x 5 1/4" x 73 1/2"	-	-	1	1	-	-	-	-
10	190-01311	Scraper blade, TIVAR not reversible 1" x 5 1/4" x 79 1/2"	-	-	-	-	1	1	1	1
11	140-09341	TIVAR blade bolting plate 1/4" x 2" x 67 1/2"	1	1	-	-	-	-	-	-
11	140-09681	TIVAR blade bolting plate 1/4" x 2" x 73 1/2"	-	-	1	1	-	-	-	-
11	140-03971	TIVAR blade bolting plate 1/4" x 2" x 79 1/2"	-	-	-	-	1	1	1	1
12	110-12971	TIVAR blade holder 3/8" x 5 1/2" x 67 1/2"	1	1	-	-	-	-	-	-
12	110-13641	TIVAR blade holder 3/8" x 5 1/2" x 73 1/2"	-	-	1	1	-	-	-	-
12	110-08321	TIVAR blade holder 3/8" x 5 1/2" x 79 1/2"	-	-	-	-	1	1	1	1
13	319-38370	Plow bolt 7/16" NC x 2 1/2" lg + nut & lock washer	7	7	8	8	8	8	8	8
14	Std.	Bolt 1/2" NC x 3/4" lg + nut & lock washer	4	4	4	4	4	4	4	4
15	130-16683	Mounting plate for speed reducer 1000@540 "left"	1	1	1	1	1	1	1	1
16	Std.	Bolt 1/2"NC x 1 1/2" lg + nylon locknut & flat washer (x)	4	4	4	4	4	4	4	4
17	8348	Speed reducer 1000@540 "triple chain"	1	-	1	-	1	-	1	-
18	110-12961	Hinged PTO shroud for speed reducer 1000@540	1	-	1	-	1	-	1	-
19	8201-1	P.T.O. T60, QD 1 3/8"-21 splines, SBI 1 3/8"-6	1	1	1	1	1	1	1	1

P.T.O. SHAFT # 8114-EG (T50)

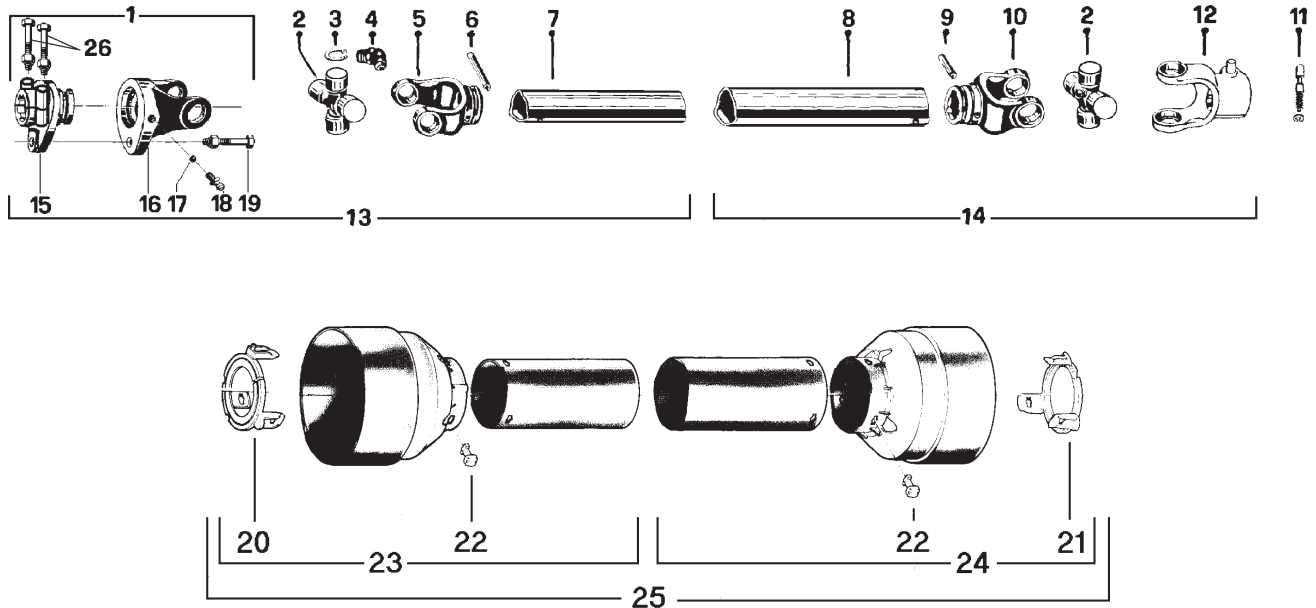

REF.	PART #	DESCRIPTION	QTY
1	8221	Safety shear yoke (2 bolts)	1
2	8073	U joint + 4 retaining rings + 1 grease fitting	2
3	8061	Retaining ring	8
4	8110	Grease fitting	2
5	8079	Yoke for inner tube	1
6	6341	Stopper for inner tube	1
7	8077	Inner tube	1
8	8076	Outer tube	1
9	8142	Stopper for outer tube	1
10	8074	Yoke for outer tube	1
11	8068-E	Yoke stopper 1 11/16"	1
12	8113	Yoke with hole 1 3/8"-6 splines + yoke stopper	1
13	8235	P.T.O. section, side with safety shear bolt, inner part, without protector	1
14	8236	P.T.O. section, side without safety shear bolt, outer part, without protector	1
15	8223	Adaptor (2 bolts)	1
16	8069	Yoke and shearplate	1
17	8070	Ball	17
18	8071	Grease fitting	1
19	8072	Safety shear bolt M10 x 50mm	1
20	8084-E	Bearing ring for inner guard tube	1
21	8083-E	Bearing ring for outer guard tube	1
22	8109	Stopper	6
23	8086	Inner shield	1
24	8085	Outer shield	1
25	8087	Complete shield	1
26	8222	Bolt M12 x 70mm + lock nut	2

P.T.O. SHAFT # 8202 & 8202-1 (T60)

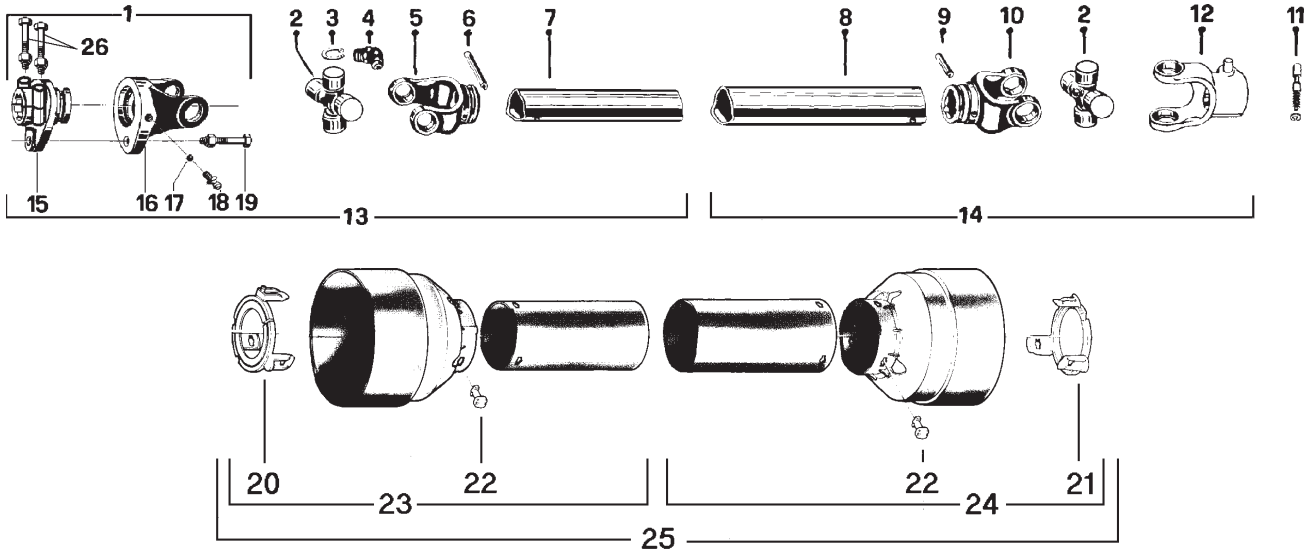

REF.	PART #	DESCRIPTION	QTY	
			8202	8202-1
1	8237	Safety shear yoke (2 bolts)	1	1
2	8238	U joint + 4 retaining rings + 1 grease fitting	2	2
3	8061	Retaining ring	8	8
4	8110	Grease fitting	2	2
5	8239	Yoke for inner tube	1	1
6	8075	Stopper for inner tube	1	1
7	8077	Inner tube	1	1
8	9212	Outer tube	1	1
9	9210-E	Stopper for outer tube	1	1
10	8240	Yoke for outer tube	1	1
11	8068-E	Yoke stopper 1 11/16"	1	1
12	8250	Yoke with hole 1 3/8"-6 splines + yoke stopper	1	-
12	8250-1	Yoke with hole 1 3/8"-21 splines + yoke stopper	-	1
13	8241	P.T.O. section, SBI 1 3/8"-6, inner part, without protector	1	1
14	8242	P.T.O. section, QD 1 3/8"-6, outer part, without protector	1	-
14	8242-1	P.T.O. section, QD 1 3/8"-21, outer part, without protector	-	1
15	8243	Adaptor (2 bolts)	1	1
16	8244	Yoke and shearplate	1	1
17	9205	Ball	17	17
18	8071	Grease fitting	1	1
19	8218	Safety shear bolt M10 x 60mm	1	1
20	8245	Bearing ring for inner guard tube	1	1
21	8246	Bearing ring for outer guard tube	1	1
22	8109	Stopper	6	6
23	8247	Inner shield	1	1
24	8248	Outer shield	1	1
25	8249	Complete shield	1	1
26	8222	Bolt M12 x 70mm + lock nut	2	2

P.T.O. SHAFT # 9225-EG, 9225-1 & 9569 (T80)

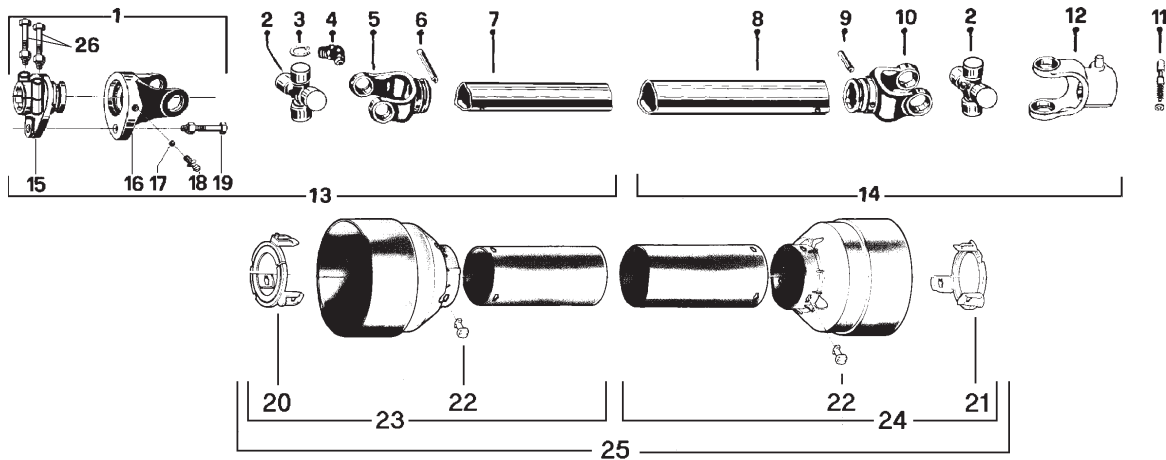

REF.	PART #	DESCRIPTION	9225-EG	9225-1	9569
or [1	9570	Safety shear yoke M10 (2 bolts) 1 3/4" - 20 splines	-	-	1
1	9453	Safety shear yoke M12 (2 bolts) 1 3/4" - 20 splines	1	-	1
1	9464-2	Safety shear yoke M10 (2 bolts) 1 3/8" - 6 splines	-	1	-
2	9208	U-joint + 4 retaining rings + 1 grease fitting	2	2	2
3	9454	Retaining ring	8	8	8
4	8110	Grease fitting	2	2	2
5	9214	Yoke for inner tube	1	1	1
6	8075	Stopper for inner tube	1	1	1
7	9212	Inner tube	1	1	1
8	9211	Outer tube	1	1	1
9	9210-E	Stopper for outer tube	1	1	1
10	9209	Yoke for outer tube	1	1	1
11	8068	Yoke stopper 1 3/8"	2	2	2
12	9455	Yoke with hole 1 3/8"-6 splines + yoke stopper	1	1	-
12	9463	Yoke with hole 1 3/8"-21 splines + yoke stopper	-	-	1
12	9224	Yoke with hole 1 3/4"-20 splines + yoke stopper	-	-	opt.
13	9456	P.T.O. section, SBI 1 3/4"-20, inner part, without protector	1	-	1
13	9456-1	P.T.O. section, SBI 1 3/8"-6, inner part, without protector	-	1	-
14	9457	P.T.O. section, QD 1 3/8"-6, outer part, without protector	1	1	-
14	9457-2	P.T.O. section, QD 1 3/8"-21, outer part, without protector	-	-	1
or [15	9458	Adaptor 1 3/4"-20 splines (2 bolts) (hole 12 mm)	1	-	1
or [15	9571	Adaptor 1 3/4"-20 splines (2 bolts) (hole 10 mm)	-	-	1
15	9458-2	Adaptor 1 3/8"-6 splines (2 bolts) (hole 10 mm)	-	1	-
or [16	9204	Yoke and shearplate (hole 12 mm)	1	-	1
or [16	9572	Yoke and shearplate (hole 10 mm)	-	-	1
16	9572	Yoke and shearplate (hole 10 mm)	-	1	-
17	9205	Ball	17	17	17
18	8071	Grease fitting	1	1	1
19	9207	Safety shear bolt M12 x 65 mm	1	-	-
19	8218	Safety shear bolt M10 x 60 mm	-	1	-
or [19	9207-375	Safety shear bolt M12 x 65 mm diam. 3/8"	-	-	1
or [19	8218	Safety shear bolt M10 x 60 mm	-	-	1
20	9459	Bearing ring for inner guard tube	1	1	1
21	9460	Bearing ring for outer guard tube	1	1	1
22	8109	Stopper	6	6	6
23	9221	Inner shield	1	1	1
24	9220	Outer shield	1	1	1
25	9222	Complete shield	1	1	1
26	9461	Bolt M12 x 90mm + lock nut	2	2	2

10

GEAR BOX # 8251 (T27D)

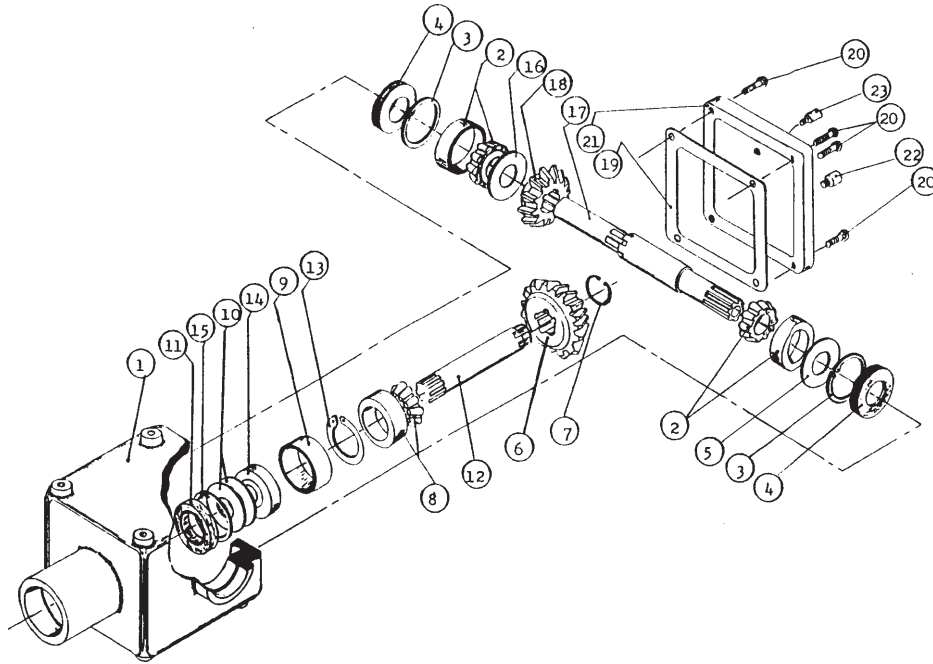

REF.	PART #	DESCRIPTION	QTY
1	8043	Casing	1
2	8044	Roller bearing no. 30208	2
3	8045	Inside circlip 80mm	2
4	8046	Oil seal 40 x 80 x 12mm	2
5	8047	Adjusting washer	1
6	8048	Gear Z18	1
7	8049	Outside circlip 40mm	1
8	8050	Roller bearing no. 30207	1
9	8051	Spacer ring	1
10	8052	Adjusting washer	2
11	8053	Oil seal 35 x 72 x 12mm	1
12	8054	Side shaft (1 1/4" - 19 splines)	1
13	8055	Inside circlip 72mm	1
14	8056	Ball bearing no. 6207	1
15	8057	Outside circlip 35mm	1
16	8058	Adjusting washer	1
17	8252	Impeller shaft (1.575" & 1 3/8" - 6 splines)	1
18	8060	Gear Z-18	1
19	8061	Gasket	1
20	8062	Bolt M10 x 14mm	4
21	8063	Cover	1
22	8064	Oil plug	1
23	8065	Oil filler plug	1

REDUCTION GEAR BOX # 9575, 8348

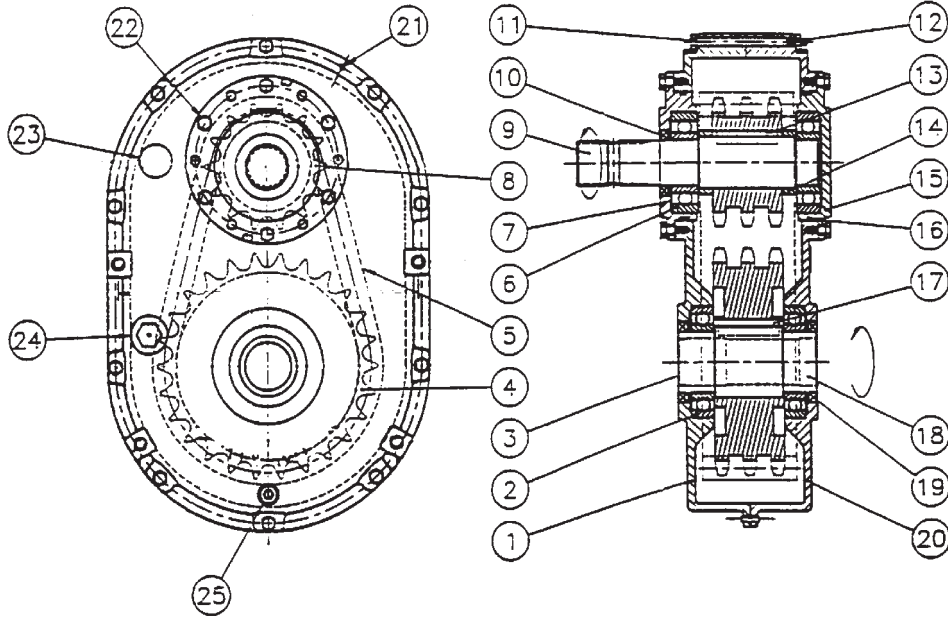

REF.	PART #	DESCRIPTION	QTY	
			9575	8348
1	9546	Casing with plug	1	1
2	6212-RS	Bearing 6212	2	2
3	9547	Seal cover (47 x 7)	1	1
4	9548	Sprocket 80-3A26	1	1
5	9549	Chain 80-3 x 36" lg	1	1
6	6309-RS	Bearing 6309	2	2
7	9550	Input cover with hole	1	1
8	9551	Sprocket 80-3A14	1	1
9	9552	Input shaft 1 3/4"-20 splines	1	-
9	8349	Input shaft 1 3/8"-6 splines	-	1
9	9553	Oil seal (45x65x8) TC double lips	1	1
11	Std.	Bolt 5/16" NC x 4 1/2" lg	10	10
12	Std.	Nut 5/16" NC	10	10
13	9554	Square key 1/2" x 2 1/2"	1	1
14	9555	Spacer (2 - 2 3/8 - 0.568)	2	2
15	9556	Input cover w/o hole	1	1
16	9557	O-ring AS-248	2	2
17	9558	Square key 5/8" x 2 1/2"	1	1
18	9559	Output shaft 1 3/4"-20 splines	1	-
18	8350	Output shaft 1 3/8"-6 splines	-	1
19	9560	Oil seal (60 x80x10) TC double lips	2	2
20	9561	Casing w/o plug	1	1
21	9562	Slotted spring pin 3/16" x 3/4"	2	2
22	Std.	Bolt 3/16" NC x 3/4" lg	12	12
23	9563	Air vent 1/2" NPT	1	1
24	9564	Sight glass 3/4" NPT	1	1
25	9565	Drain plug 1/2" NPT	1	1

10

CYLINDER 25TR08

15050

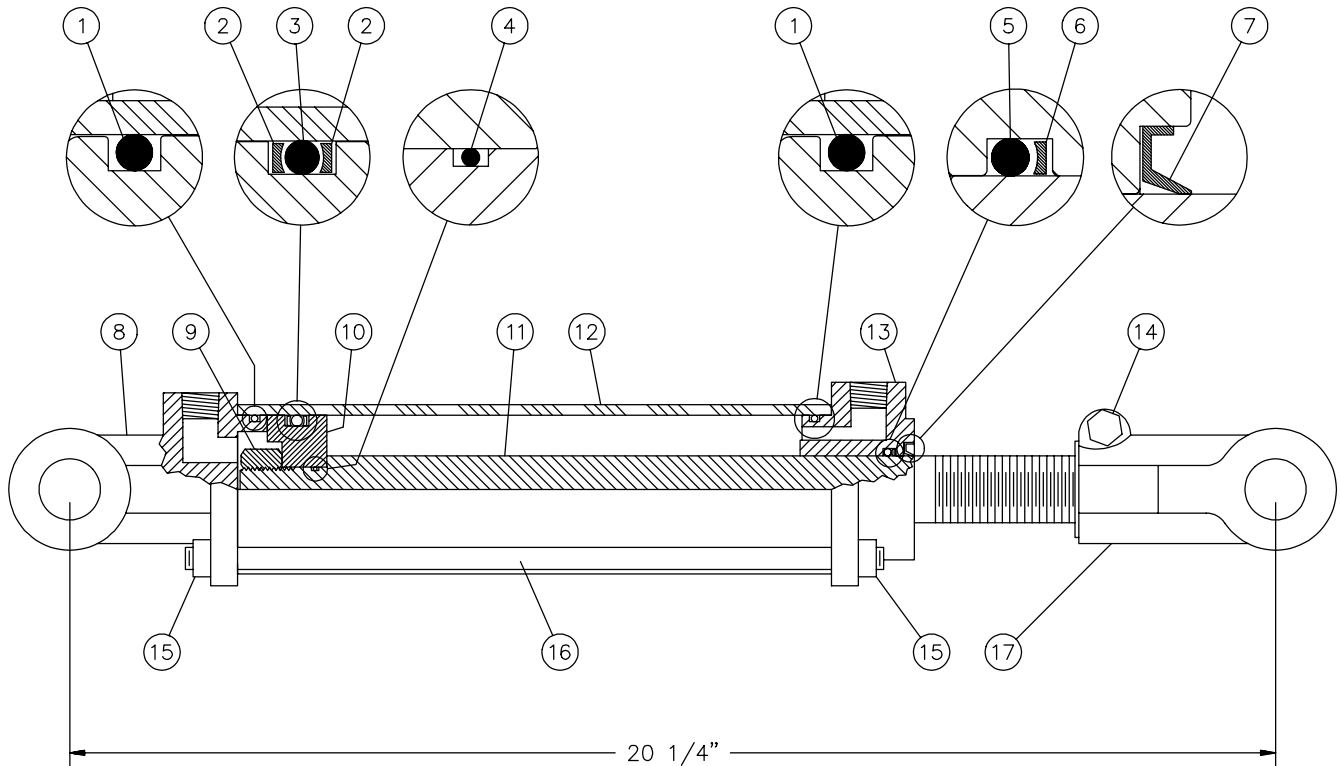

REF.	PART #	DESCRIPTION	QTY
1	See #RK25TR	O-ring 1/8" x 2 1/4" x 2 1/2"	2
2	See #RK25TR	Back-up 2 1/2" o.d. x 3/16 ø	2
3	See #RK25TR	O-ring 3/16" x 2 1/8" x 2 1/2"	1
4	See #RK25TR	O-ring 1/16" x 5/8" x 3/4"	1
5	See #RK25TR	O-ring 1/8" x 1 1/8" x 1 3/8"	1
6	See #RK25TR	Back-up 1 3/8" o.d. x 1/8" ø	1
7	See #RK25TR	Wiper 1 1/8" i.d. x 1 5/8" o.d.	1
8	492401	Yoke (for 2 1/2" tube)	1
9	Std.	Nut 3/4" NF	1
10	4924-31	Piston 2 1/2" ø	1
11	492028	Piston rod 1 1/8"	1
12	491668	Cylinder body 2 1/2" ø	1
13	492421	Head (for 2 1/2" tube)	1
14	Std.	Bolt 3/8" NC x 2 1/4" + nut	1
15	Std.	Nut 3/8" NC	8
16	Std.	Threaded rod 3/8" NC x 12" lg	4
17	458599	Yoke (for 1 1/8" rod)	1
NI*	8183	Pin 1" ø + cotter pin	2
NI*	RK25TR	Repair kit for cylinder 2 1/2" (includes # 1, 2, 3, 4, 5, 6, & 7)	1

*NI = NOT ILLUSTRATED

HYDRAULIC MOTOR # DH 250 & DH 315

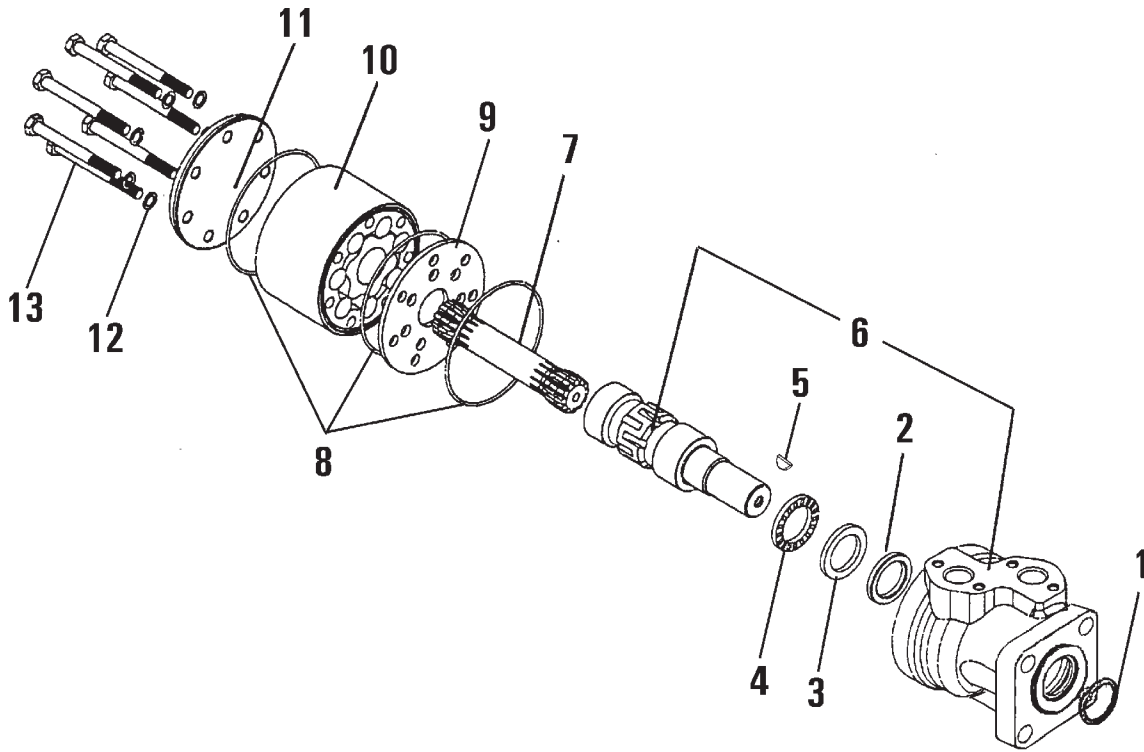







REF.	CODE #	DESCRIPTION	QTY	
			DH 250	DH 315
1	633B0370	Dust seal ring	1	1
2	633B0414	Shaft seal BAKDH ring	1	1
3	151-5708	Bearing race	1	1
4	151-5709	Axial needle bearing	1	1
5	682L9054	Woodruff key	1	1
6	-----	Housing and output shaft		not sold
7	151-2649	Cardan shaft	1	-
7	151-2650	Cardan shaft	-	1
8	633B1173	O-ring	3	3
9	151-1713	Distributor plate	1	1
10	151-1193	Gear wheel set	1	-
10	151-1186	Gear wheel set	-	1
11	151-2673	End cover	1	1
12	684X0076	Washer	6	6
13	681X0184	Screw M8 x 1.25mm Din 931 x 60mm lg	6	-
13	681X0186	Screw M8 x 1.25mm Din 931 x 70mm lg	-	6
NI*	151-1286	Set of seals	1	1





*NI = NOT ILLUSTRATED

TORQUE CHART

TORQUE SPECIFICATION TABLE

Thread UNC and UNF		Grade 2 				Grade 5   				Grade 8*   			
Bolt size		Torque				Torque				Torque			
Inches	mm	Pound feet min.	max.	Newton meters min.	max.	Pound feet min.	max.	Newton meters min.	max.	Pound feet min.	max.	Newton meters min.	max.
1/4	6.35	5	6	6.8	8.13	9	11	12.2	14.9	12	15	16.3	30.3
5/16	7.94	10	12	13.6	16.3	17	20.5	23.1	27.8	24	29	32.5	39.3
3/8	9.53	20	23	27.1	31.2	35	42	47.5	57.0	45	54	61.0	73.2
7/16	11.11	30	35	40.7	47.4	54	64	73.2	86.8	70	84	94.9	113.9
1/2	12.70	45	52	61.0	70.5	80	96	108.5	130.2	110	132	149.2	179.0
9/16	14.29	65	75	88.1	101.6	110	132	149.2	179.0	160	192	217.0	260.4
5/8	15.88	95	105	128.7	142.3	150	180	203.4	244.1	220	264	298.3	358.0
3/4	19.05	150	185	203.3	250.7	270	324	366.1	439.3	380	456	515.3	618.3
7/8	22.23	160	200	216.8	271.0	400	480	542.4	650.9	600	720	813.6	976.3
1	25.40	250	300	338.8	406.5	580	696	786.5	943.8	900	1080	1220.4	1464.5
1 1/8	25.58	-	-	-	-	800	880	1084.8	1193.3	1280	1440	1735.7	1952.6
1 1/4	31.75	-	-	-	-	1120	1240	1518.7	1681.4	1820	2000	2467.9	2712.0
1 3/8	34.93	-	-	-	-	1460	1680	1979.8	2278.1	2380	2720	3227.3	3688.3
1 1/2	38.10	-	-	-	-	1940	2200	2630.6	2983.2	3160	3560	4285.0	4827.4

* Thick nuts must be used with grade 8 bolts.

Size of screw	Thread	Pitch (mm)	Grade 4T  				Grade 7T 				Grade 8T  			
			Torque				Torque				Torque			
			Pound feet min.	max.	Newton meters min.	max.	Pound feet min.	max.	Newton meters min.	max.	Pound feet min.	max.	Newton meters min.	max.
M6	UNC	1.00	3.6	5.8	4.9	7.9	5.8	9.4	7.9	12.7	7.2	10	9.8	13.6
M8	UNC	1.25	7.2	14	9.8	19	17	22	23	29.8	20	26	27.1	35.2
M10	UNC	1.5	20	25	27.1	33.9	34	40	46.1	54.2	38	46	51.5	62.3
M12	UNC	1.75	28	34	37.9	46.1	51	59	69.1	79.9	57	66	77.2	89.4
M14	UNC	2.0	49	56	66.4	75.9	81	93	109.8	126	96	109	130.1	147.7
M16	UNC	2.0	67	77	90.8	104.3	116	130	157.2	176.2	129	145	174.8	196.5
M18	UNC	2.0	88	100	119.2	136	150	168	203.3	227.6	175	194	237.1	262.9
M20	UNC	2.5	108	130	146.3	176.2	186	205	252	277.8	213	249	288.6	337.4
M8	UNF	1.0	12	17	16.3	23	19	27	25.7	36.6	22	31	29.8	42
M10	UNF	1.25	20	29	27.1	39.3	35	47	47.4	63.7	40	52	54.2	70.5
M12	UNF	1.25	31	41	42	55.6	56	68	75.9	92.1	62	75	84	101.6
M14	UNF	1.5	52	64	70.5	86.7	90	106	122	143.6	107	124	145	168
M16	UNF	1.5	69	83	93.5	112.5	120	138	162.6	187	140	158	189.7	214.1
M18	UNF	1.5	100	117	136	158.5	177	199	239.8	269.6	202	231	273.7	313
M20	UNF	1.5	132	150	178.9	203.3	206	242	279.1	327.9	246	289	333.3	391.6

Use the above torques when special torque is not given.

NOTE: These values apply to fasteners as received from supplier, dry, or when lubricated with normal engine oil. They do not apply if extreme pressure lubricants are used.

WARRANTY

12

PRONOVOST warrants this product to the initial purchaser for the period of one year from the date of purchase against defects in materials and workmanship.

We will replace or repair defective parts free of charge if they are returned to our plant in St-Tite, Quebec, Canada.

Transportation charges are the responsibility of the customer. This warranty is not transferable.

Hydraulic cylinders and motors are covered by the manufacturer of these items.

All PRONOVOST spare parts purchased are covered by a three (3) month warranty.

This warranty becomes void and nul if the equipment is modified, breaks down as the result of an accident, is not operated according to manufacturer's recommendations, damaged by negligence or if maintenance has not been carried out as specified.

Our obligation is limited to the replacement or repair of the defective part. PRONOVOST accepts no responsibility for direct or indirect consequential damages of any kind.

Ce manuel est aussi disponible en français.
Veuillez téléphoner.



INNOVATION - EXCELLENCE

LES MACHINERIES PRONOVOST INC.

260, route 159,

Saint-Tite, Quebec, Canada, G0X 3H0

Tel.: (418) 365-7551, Fax: (418) 365-7954

www.pronovost.qc.ca