



**OPERATOR'S / PARTS
MANUAL**



Snowblowers
Models

P-540	P-620
P-680 & P-680TRC	P-720 & P-720TRC
P-720-74 & P-720TRC-74	P-720-80 & P-720TRC-80



Copyright © Les Machineries Pronovost Inc., 2011

All rights reserved.
Printed in Canada.

TABLE OF CONTENTS

Section	Item	Page
1	Introduction	5
2	Safety	6
	General Safety	6
	Safety in Operation	6
	Safety with Maintenance	7
	Safety in Transport	7
	Safety in Storage	7
3	Decals	8
	Safety Decals	8
	Maintenance Decals	12
4	Assembly	13
	General assembly	13
5	Start-up	14
	Basic Start-up Procedures	14
6	Maintenance	15
7	Storage	16
8	Trouble Shooting	17
9	Specifications	19
10	Parts List	20
	Snowblowers P-540, P-620	20
	Snowblowers P-680, P-720	23
	Snowblowers P-680TRC, P-720TRC	26
	Snowblowers P-720-74, P-720-80	29
	Snowblowers P-720TRC-74, P-720TRC-80	32
	Manual Chute Kit MR-4864	35
	Hydraulic Chute Kit: Motor SP-4864	36
	Semi-industrial Chute PSIG-5472	37
	Options	38
	P.T.O. Shaft 6408-E	40
	P.T.O. Shaft 6248-EG	41
	P.T.O. Shaft 8114-EG	42
	Gear box 6451	43
	Gear Box 8251	44
	Cylinder 25TR04	45
	Hydraulic Motor MLH100, MLH125 & MLH250	46
11	Torque Chart	47
12	Warranty	48

INTRODUCTION

CONGRATULATIONS!

Thank you for choosing PRONOVOST. We are confident this equipment will meet your requirements in terms of quality, performance and reliability.

This manual was prepared to assist you in the safe operation of your new Snowblower. It contains important information which will help you achieve excellent returns with your Snowblower for years to come.

Please read this manual completely before operating your Snowblower and keep it for future reference.

Before starting the machine, you or any other person who will be operating the Snowblower must familiarize yourself with the safety recommendations and the operating instructions. Please read carefully and be sure to understand and follow all recommendations and procedures.

In this manual, the right and left sides are identified as shown on Figure 1A.

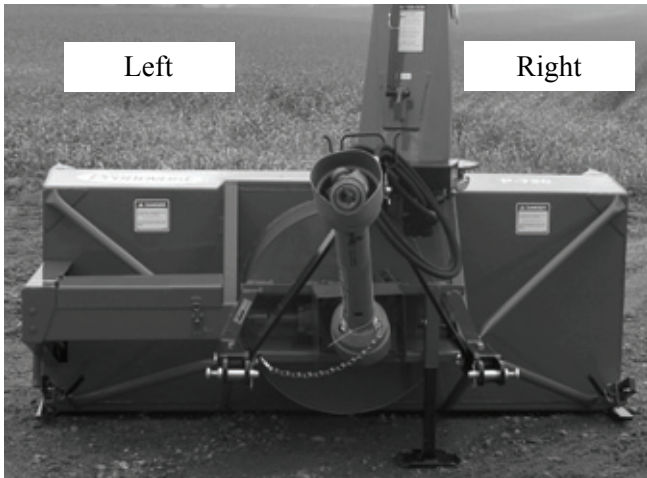

Figure 1A

If you require additional information on your Snowblower, please contact your PRONOVOST Dealer.

NOW take a moment to enter the model, serial number and the date of purchase of your Snowblower in the space provided.

When ordering parts from your Dealer, please refer to these numbers for a fast and efficient service. Use PRONOVOST parts for replacement.

The model and serial numbers are on the name plate shown on Fig. 1B.



Figure 1B

MODEL: _____ ✍

SERIAL NO: _____ ✍

DATE OF PURCHASE: _____ ✍

SAFETY

GENERAL SAFETY

2

WHEN YOU SEE THIS SYMBOL



ATTENTION!

**BE ALERT
YOUR SAFETY IS INVOLVED**

This symbol «SAFETY ALERT» is used in this manual and on the safety decals on the Snowblower. It warns you of the possibility of danger. Carefully read, understand and follow all safety recommendations before operating the Snowblower.

- 1) Careful operation is the best assurance against accidents. Carefully read this manual and follow all recommendations before operating your Snowblower. It is the owner's responsibility to make sure that anyone who will operate the Snowblower will read this manual before operating the equipment.
- 2) Familiarize yourself with all controls and always be ready to stop the Snowblower quickly in case of emergency.
- 3) Never let a child operate the Snowblower.
- 4) Do not modify the Snowblower. Any non authorized modification may affect the efficiency and/or safety of the equipment and will automatically void the warranty.
- 5) Never operate the Snowblower with defective parts or if damaged in any way. Have it repaired before operating.
- 6) Make sure all fasteners are in place and properly secured or tightened. Refer to torque chart on page 47.
- 7) Avoid wearing loose fitting clothing when working with the Snowblower. These could get entangled in moving parts of the equipment and cause accidents.

- 8) Prolonged exposure to noise may hamper hearing. Protect yourself by wearing adequate protection devices.
- 9) Hydraulic fluids under pressure can damage your skin. Do not use your hands to locate a leak.
- 10) Before the beginning of the snow season, inspect all areas where the Snowblower will be used and remove any object which may cause an accident and/or damage the equipment.
- 11) Never operate your Snowblower in poor visibility or without proper lighting conditions.

SAFETY IN OPERATION

- 1) Be sure there are no obstructions around the equipment and that no one stands near the equipment when in operation.
- 2) Do not operate an engine in a confined or non ventilated area.
- 3) Do not perform any adjustments, cleaning, maintenance or repairs with the engine running. The engine must be stopped and the P.T.O. disengaged. Preferably remove the key from the ignition.
- 4) Wear adequate clothing when working in cold or windy conditions.
- 5) Adjust skid shoes for proper ground clearance of scraper blade, especially in rough terrain or soft ground conditions.
- 6) Before operating, make sure the P.T.O. is properly installed and secured.
- 7) Before starting-up the Snowblower, make sure the auger and drum areas are free of ice.
- 8) Put P.T.O. control in neutral position before starting engine.
- 9) Keep hands, feet and clothing away from moving parts of the Snowblower. Stay away from the discharge chute.

SAFETY (cont'd)

- 10) Before unplugging the chute, always disengage the P.T.O., stop the engine and relieve all hydraulic pressures.
- 11) Do not operate in excessive inclined conditions. Be careful when turning in slopes.
- 12) Never operate your Snowblower with missing guards or without protective devices in place.
- 13) Do not operate your Snowblower near buildings, windows or other vehicles without prior and proper adjustment of the chute deflector.
- 14) Never aim discharge chute towards people or animals. This may cause serious injuries.
- 15) Always reduce operating speed in slippery conditions.
- 16) Be careful when backing-up, make sure you have good visibility.
- 17) Always be on the lookout for objects which may enter the Snowblower.
- 18) If undue vibrations are felt, disengage the P.T.O., stop the motor and look for the cause of the vibration. Vibration is usually the indication of a problem.
- 19) At the end of the operation, disengage the P.T.O., lower the Snowblower, put transmission in neutral, apply parking brake, stop engine and remove the key from the ignition.

SAFETY WITH MAINTENANCE

- 1) Perform the Snowblower maintenance according to recommendations contained in this manual.

- 2) Stop engine and relieve all hydraulic pressures before doing inspection, maintenance or repairs.
- 3) Never perform any work under the Snowblower while it is supported only by the tractor's hydraulic system. It must be completely supported by wooden blocks or other safe means.

SAFETY IN TRANSPORT

- 1) On public roads, use proper safety lights and check local regulations.
- 2) Be alert while driving on the road. Never carry passengers.
- 3) Always disengage P.T.O. while moving from one area of work to another.
- 4) It is recommended to use both brake pedals simultaneously for better control.
- 5) The recommended road speed should be such as to maintain full control over steering and braking.
- 6) Be careful while backing up, make sure you have good visibility.

SAFETY IN STORAGE

- 1) Provide adequate supports to prevent any accidental overturning of the Snowblower.
- 2) Do not let children play in the area where the Snowblower is stored.

2

DECALS

SAFETY DECALS

The safety decals are affixed wherever special safety precautions are indicated. Locate them on the machine and read them carefully. If a decal is damaged, lost or illegible, install a new one. The following photos indicate where each one must be installed.

3

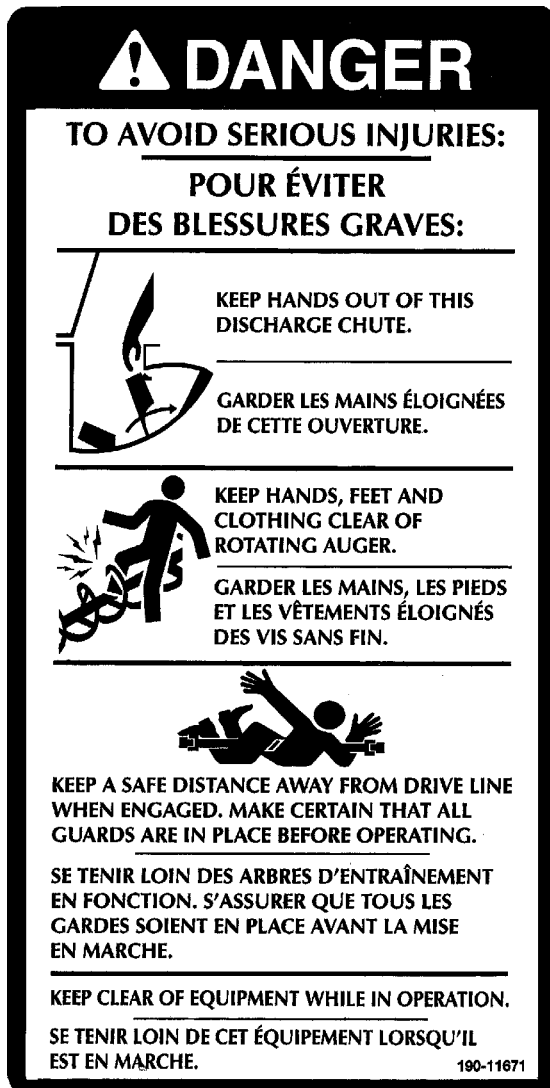

Figure 2
Decal A

Part no.: 190-11671

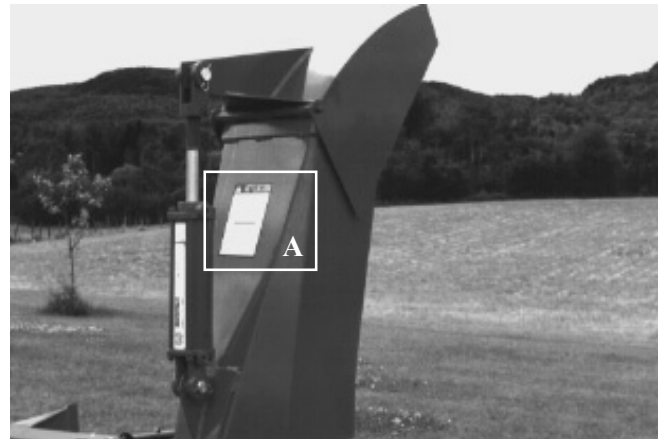

Figure 3

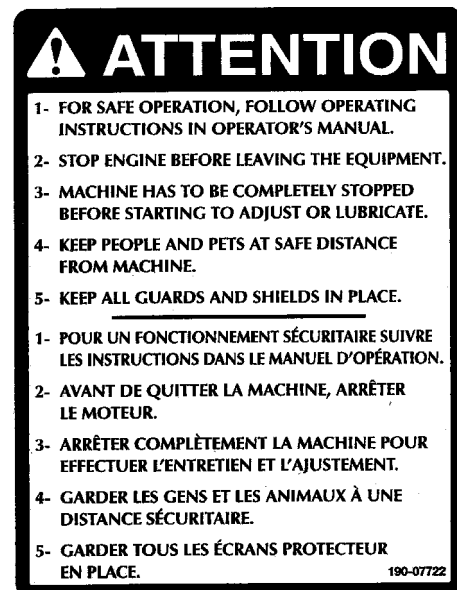

Figure 4
Decal B

Part no.: 190-07722

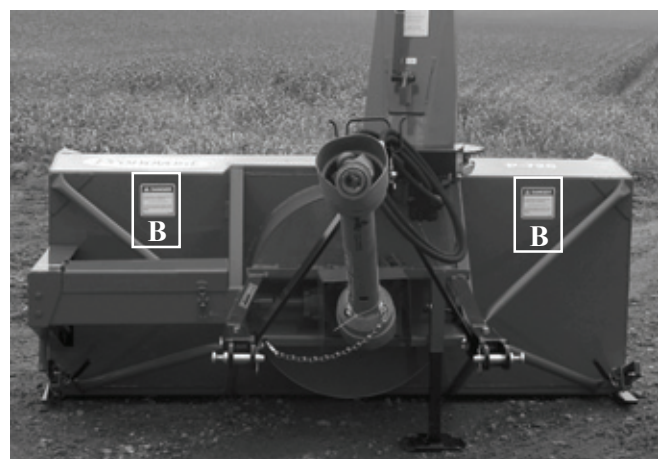

Figure 5

DECALS (cont'd)



Figure 6



Figure 7
Decal C

Part no.: 190-11641

Decal E in Fig. 8 is located directly on the P.T.O. shaft. It is not visible when the safety shield is in place. It must never be visible when you operate the equipment.



Figure 8
Decal E

Part no.: A108

3

DECALS (cont'd)

3

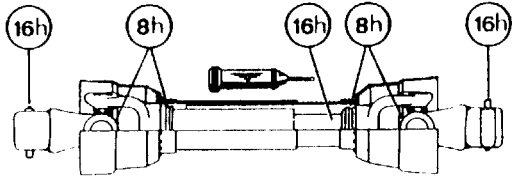

Figure 9
Decal F Part no.: A 109

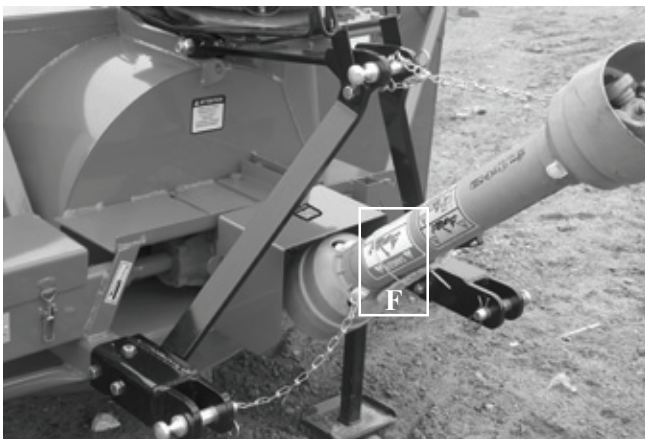

Figure 10



Figure 11
Decal D Part no.: PD-91-01

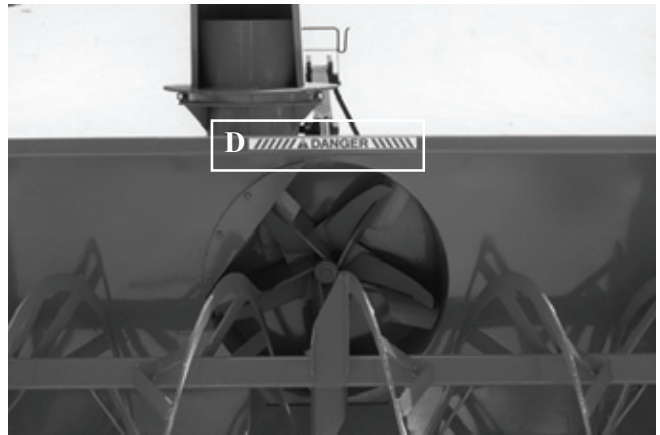

Figure 12

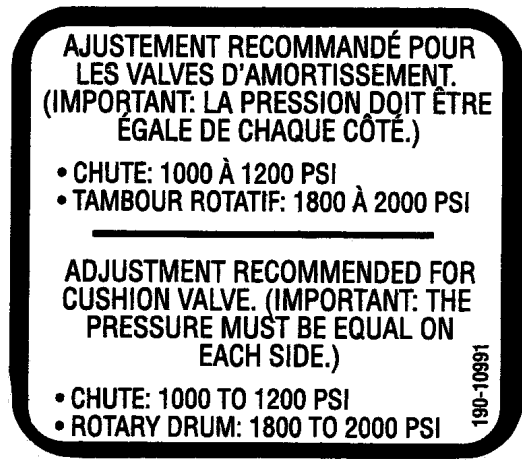

Figure 13
Decal G Part no.: 190-10991

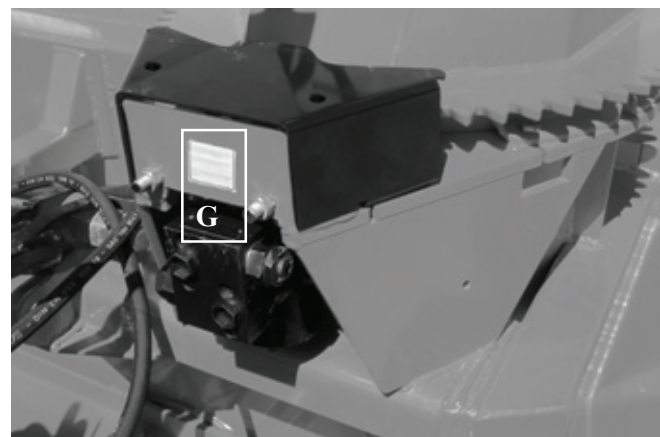

Figure 14

DECALS (cont'd)

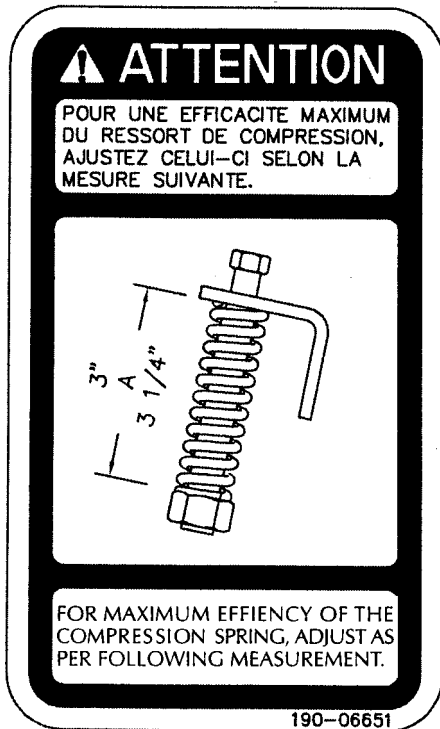

Figure 15
Decal H

Part no.: 190-06651

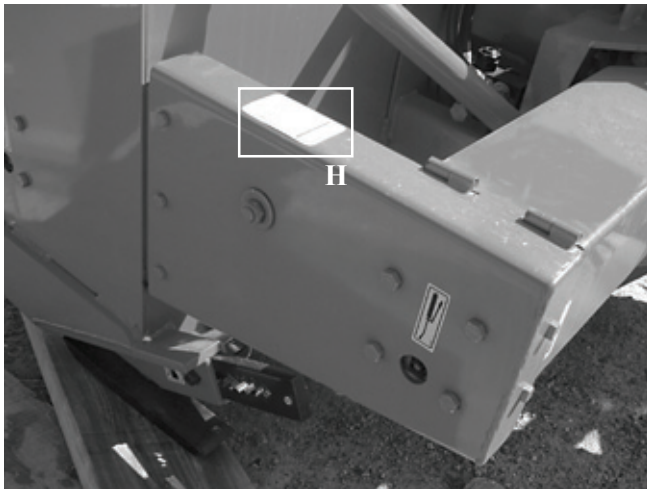

Figure 16

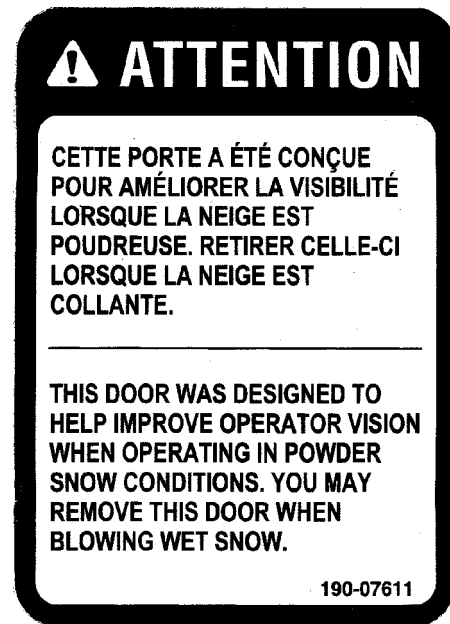

Figure 17
Decal J

Part no.: 190-07611



Figure 18

DECALS (cont'd)

MAINTENANCE DECALS

The maintenance decals indicate the points requiring lubrication. Refer to maintenance section for more details.

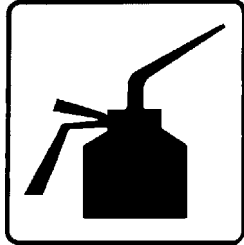

Figure 19

Part no.: A 105



Figure 20

Part no.: A 106



Figure 21

Decal K

Part no.: 190-11581

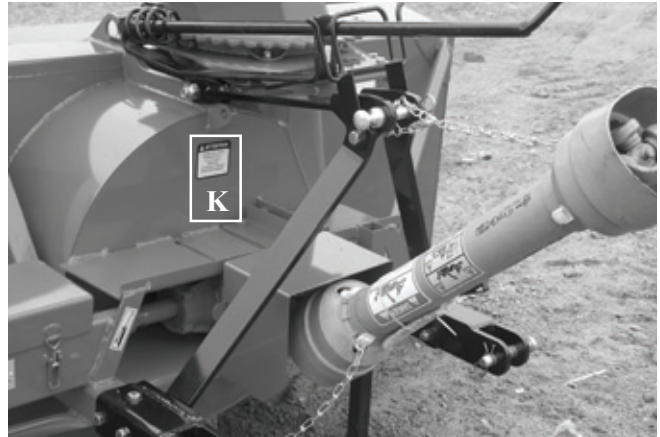

Figure 22

ASSEMBLY



Figure 23



Figure 24

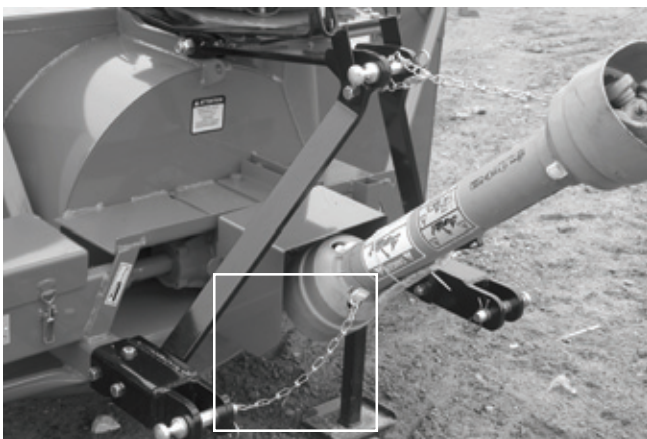

Figure 25

ASSEMBLY

- 1) The Snowblower is shipped partly assembled.
- 2) Install 3-point system according to the model of your Snowblower. (See section 10 for parts numbers). Use the holes most convenient to the type of tractor used (Fig. 23).
- 3) Install P.T.O. shaft with the shear pin end onto the Snowblower gear box (Fig. 24). Then attach safety shield support chain as shown (Fig. 25).
WARNING: The telescoping tubes of the drive shaft must never be allowed to bottom out while maintaining a minimum overlap of 6 inches.
- 4) If you install a hydraulic cylinder on the chute deflector, use model 25TR04 cylinder.
- 5) For the installation of the chute rotation mechanism, please refer to parts section, according to the type used.

4

STARTING-UP



Figure 26

5

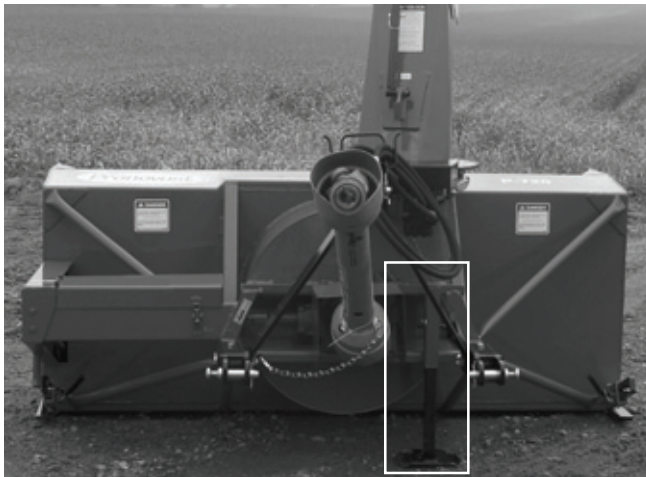

Figure 27

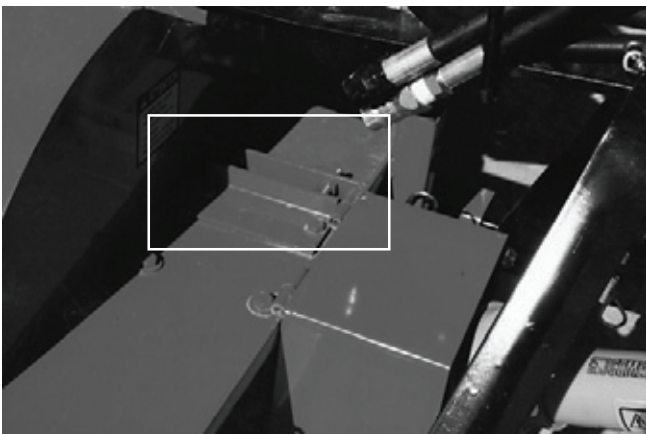

Figure 28

START-UP PROCEDURES

- 1) Check oil level in gearbox. Use SAE 80W90 gear box oil.
- 2) Lubricate all points with a good quality multipurpose grease.
- 3) Check chain take-up adjustment. The spring maintaining the tension must be compressed to a length between 3" and 3 1/4".
- 4) Verify for adequate tightness of all fastening devices. Refer to torque chart on page 47.
- 5) Adjust skid shoes according to ground conditions (Fig. 26).
- 6) Following the installation of the Snowblower on the tractor, **do not forget** to lift the storage support (Fig. 27).
- 7) Make sure of a 540 RPM input to your Snowblower.
- 8) Check impeller adjustment. The tip of the blades should be approximately 1/8" to 3/16" from the discharge wall of the drum. If necessary, adjust with the take-up screws provided (Fig. 28).

MAINTENANCE

- 1) Wipe off all grease fittings with a clean cloth before adding grease in order to avoid injecting dirt and sand.
- 2) Repair or replace damaged grease fittings.
- 3) Lubricate all grease fittings every 8 hours of operation.
- 4) Oil drive chain every 8 hours of operation.
- 5) Lubricate P.T.O. shaft as indicated below:
- 7) Check tension of drive chain every 24 hours of operation and adjust if necessary.
- 8) Check for tightness of bearing collars every 48 hours of operation.
- 9) Change gearbox oil once a year. Adjust to required oil level as per drawing in Parts List section. Use SAE 80W90 oil.
- 10) Check all nuts and bolts once a year. If necessary use torque chart on page 47.

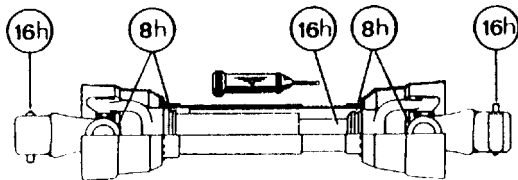

Pull out the P.T.O. and lubricate between the two tubes with low temperature grease. Drive line tubes must slide easily even in cold weather. Clean off old hardened grease and apply fresh grease as needed.

- 6) Check oil level in gear box once a month. Adjust to required oil level as per drawing in Parts List section. Use SAE 80W90 oil.
- 11) For the auger drive shaft, always use a grade 5 shear bolt.
- 12) For the PTO shaft, always use a grade 8.8 shear bolt at 540 RPM.
- 13) UHMW slides do not require lubrication except at the end of the season in order to prevent corrosion of steel components that are in contact with the UHMW material.

STORAGE

- 1) Store the Snowblower in a cool, dry place.
- 2) Support the Snowblower with wooden blocks.
- 3) Keep all piston rods in the retracted position. This will assure better protection against the elements.
- 4) Clean your Snowblower.
- 5) Thoroughly inspect all parts of the Snowblower. Replace or repair worn or defective parts.
- 6) Touch-up or repaint if necessary.
- 7) Lubricate all points before storage.

TROUBLESHOOTING

P.T.O. SHAFT

PROBLEM	POSSIBLE CAUSE	CORRECTION
<ul style="list-style-type: none"> - Premature wear of U-joints and/ or bluish color of cross journals. 	<ul style="list-style-type: none"> - Insufficient lubrication. - Excessive working angle. - Poor quality lubricant. 	<ul style="list-style-type: none"> - Follow lubrication recommendations. - Replace defective U-joints. - Make sure the Snowblower inlet face is perpendicular to the ground and if possible readjust 3-point hitch in order to position the Snowblower further away from tractor. - Use high quality lubricant.
<ul style="list-style-type: none"> - Gripping or premature wear of telescoping members. 	<ul style="list-style-type: none"> - Too much sliding under load. - Tube overlap too-short: minimum recommended is 6". - Insufficient lubrication. - Contaminants (sand, etc.). 	<ul style="list-style-type: none"> - Avoid raising Snowblower while in operation. - Readjust 3-point hitch in order to position the snowblower closer to the tractor. - Follow lubrication recommendations. - Replace defective telescopic members.
<ul style="list-style-type: none"> - Damaged or jammed locking pin or bolt. 	<ul style="list-style-type: none"> - Pin or orifice contaminated by sand, ice, etc. - Telescoping members too long, exerting pressure on locking device. 	<ul style="list-style-type: none"> - Clean and grease. - Readjust 3-point hitch in order to position the Snowblower further away from tractor or shorten tubes.
<ul style="list-style-type: none"> - Premature wear of guard tube bearing ring. 	<ul style="list-style-type: none"> - Lack of lubrication. - Wrong installation of guard chain. - Part of the guard in contact with the equipment. 	<ul style="list-style-type: none"> - Follow lubrication instructions. - Adjust chain to prevent interference between guard & equipment. - Replace worn or damaged bearing rings.
<ul style="list-style-type: none"> - Cut or deformed safety guard tubes. 	<ul style="list-style-type: none"> - Tubes in contact with the equipment. 	<ul style="list-style-type: none"> - Eliminate any interference between tubes and equipment or tractor. - Replace damaged tubes.

TROUBLESHOOTING (cont'd)

SNOWBLOWER

PROBLEM	POSSIBLE CAUSE	CORRECTION
- The snow is not being thrown as far as usual.	<ul style="list-style-type: none"> - Tractor RPM too low. - Gap too wide between impeller blade tip and drum outlet wall. - Insufficient tractor HP. 	<ul style="list-style-type: none"> - Raise P.T.O. speed to a minimum of 540 RPM. - Adjust impeller blades closer to drum outlet (1/8" to 3/16"). - Reduce travel speed.
- Frequent plugging of discharge chute.	<ul style="list-style-type: none"> - Tractor RPM too low. - Tractor RPM reduced too early with snow still in the Snowblower. - Slippage of PTO clutch mechanism. - Wet snow condition. 	<ul style="list-style-type: none"> - Raise P.T.O. speed to a minimum of 540 RPM. - Make sure the Snowblower is completely empty before reducing RPM, especially on tractors with foot controlled RPM. - Repare clutch. - Reduce travel speed. - Remove access panel.
- The impeller will not turn.	<ul style="list-style-type: none"> - Shear bolt broken on drive shaft. 	<ul style="list-style-type: none"> - Replace shear bolt.
- The auger will not turn.	<ul style="list-style-type: none"> - Shear bolt broken on drive shaft. - Shear bolt broken on auger drive shaft. - Broken drive chain. 	<ul style="list-style-type: none"> - Replace shear bolt. - Replace shear bolt. - Fix or replace chain.
- The rotating drum will not turn.	<ul style="list-style-type: none"> - Broken key on motor. - Ice accumulation. - Wrong hydraulic connections. 	<ul style="list-style-type: none"> - Replace the key. - Remove ice. - Check hydraulic connections.
- The chute will not turn.	<ul style="list-style-type: none"> - Broken key on motor. - Ice accumulation. - Wrong hydraulic connections. 	<ul style="list-style-type: none"> - Replace the key. - Remove ice. - Check hydraulic connections.

8

SPECIFICATIONS

		GROUP I					
Snowblower model		P-540	P-620	P-680	P-720	P-720 -74	P-720 -80
Snowblower model		-	-	P-680 TRC	P-720 TRC	P-720TRC -74	P-720TRC -80
Horse power recommended (HP) min.-max.		18 to 25	20 to 30	25 to 40	25 to 50	30 to 55	30 to 55
Working width	in. - (cm)	54"	62"	68"	72"	74"	80"
Cutting height	in. - (cm)	28"	28"	30"	30"	30"	30"
Height - Chute base po. - (cm)		29 ³ / ₈ "	29 ³ / ₈ "	31 ¹ / ₄ "	31 ¹ / ₄ "	33 ¹ / ₄ "	33 ¹ / ₄ "
Height - Chute base, TRC model po.-(cm)		-	-	34	34	36	36
Impeller diameter	in. - (cm)	22"	22"	24"	24"	26"	26"
Depth of drum	in. - (cm)	9"	9"	10 ¹ / ₂ "	10 ¹ / ₂ "	10 ¹ / ₂ "	10 ¹ / ₂ "
Impeller blades		4	4	4	4	4	4
Size of impeller shaft	in. - (cm)	1 ¹ / ₄ "	1 ¹ / ₄ "	1 ⁹ / ₁₆ "	1 ⁹ / ₁₆ "	1 ⁹ / ₁₆ "	1 ⁹ / ₁₆ "
Height - Impeller center	in. - (cm)	14"	14"	15"	15"	16 1/2"	16 1/2"
Impeller RPM		540	540	540	540	540	540
Number of augers		1	1	1	1	1	1
Main auger diameter	in. - (cm)	16"	16"	19"	19"	19"	19"
Drive chain - main auger		50	50	60	60	60	60
Oil bath sealed gear box		Std.	Std.	Std.	Std.	Std.	Std.
Chute rotation mechanism	Manual	Opt.	Opt.	Opt.	Opt.	Opt.	Opt.
	Hydraulic (motor)	Opt.	Opt.	Opt.	Opt.	Opt.	Opt.
Number of shear bolts		2	2	2	2	2	2
Hitch category		1	1	1	1	1	1
Balanced impeller		Std.	Std.	Std.	Std.	Std.	Std.
Balanced auger		Std.	Std.	Std.	Std.	Std.	Std.
Drum rotation for hydraulic motor		-	-	Std.	Std.	Std.	Std.
Scraper blade	Std. steel - not rev.	Std.	Std.	Std.	Std.	Std.	Std.
	Carbon steel 1/2" x 3"	Opt.	Opt.	Opt.	Opt.	Opt.	Opt.
	Stainless steel 1/2" x 3"	Opt.	Opt.	Opt.	Opt.	Opt.	Opt.
Adjustable skid shoes	Standard steel	Std.	Std.	Std.	Std.	Std.	Std.
	Carbon steel	Opt.	Opt.	Opt.	Opt.	Opt.	Opt.
	Stainless steel	Opt.	Opt.	Opt.	Opt.	Opt.	Opt.
Chute	regular	Opt.	Opt.	Opt.	Opt.	Opt.	Opt.
	semi-industrial	Opt.	Opt.	Opt.	Opt.	Opt.	Opt.
Déflecteur	manual	Opt.	Opt.	Opt.	Opt.	Opt.	Opt.
	hydraulic	Opt.	Opt.	Opt.	Opt.	Opt.	Opt.
Bearing / ductile iron casting		Std.	Std.	Std.	Std.	Std.	Std.
Lateral blades		Opt.	Opt.	Opt.	Opt.	Opt.	Opt.
P.T.O. shaft	standard	No. 2	No. 2	No. 4	No. 5	No. 5	No. 5
	optional	-	-	-	No. 6	No. 6	No. 6
Poids lbs - kg		550	575	707	712	717	735
		-	-	790	808	837	847

Design and specifications subject to change without notice.

Shaded lines apply only to models with rotary drum (TRC).

SNOWBLOWERS P-540 P-620

170-04415

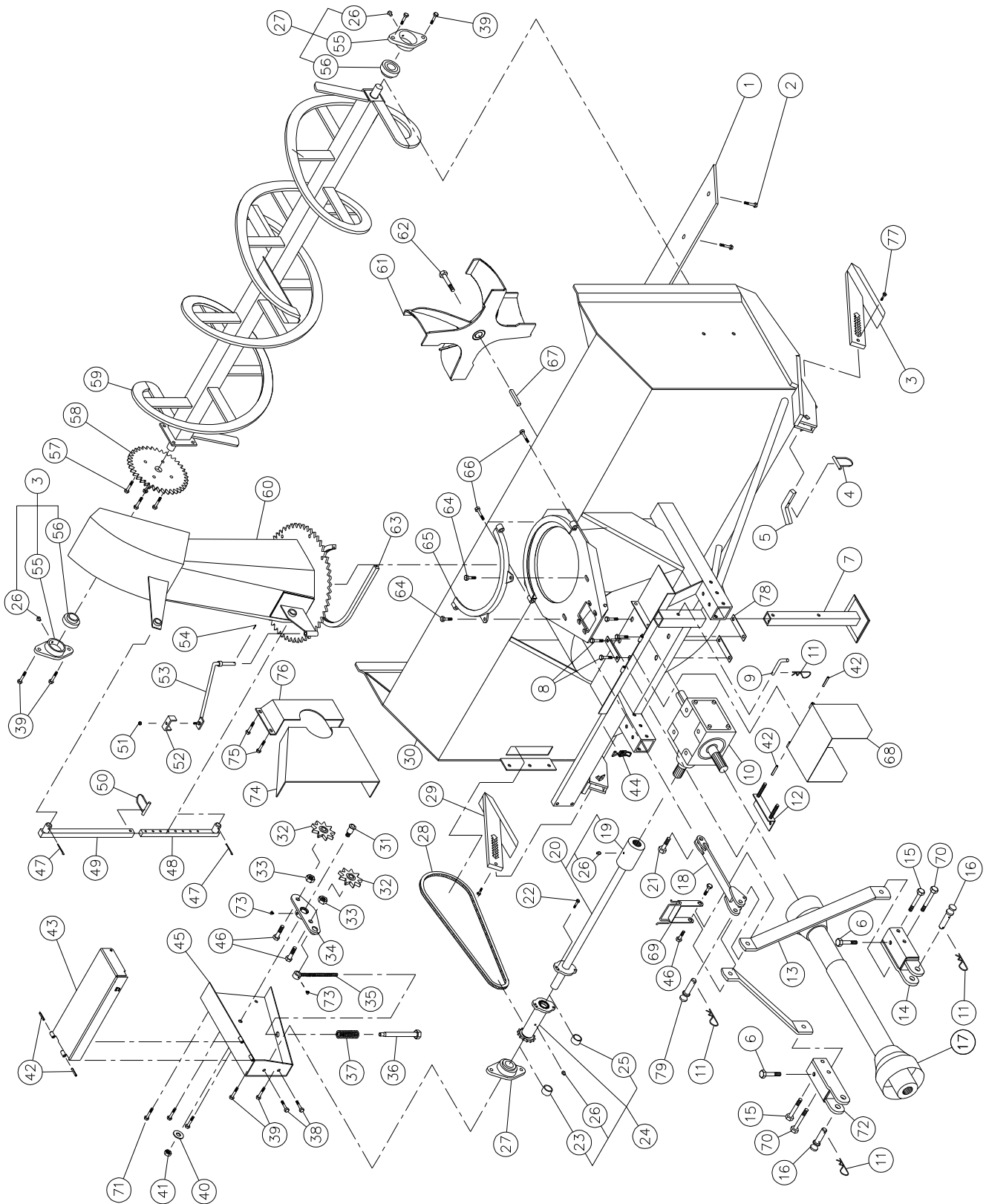

10

SNOWBLOWERS P-540 P-620 (cont'd)

REF.	PART #	DESCRIPTION	QTY	
			P-540	P-620
1	140-01251	Scraper blade (not reversible) 3/8" x 2 1/2" x 50 1/4" lg	1	-
1	140-01261	Scraper blade (not reversible) 3/8" x 2 1/2" x 58 1/4" lg	-	1
2	319-38310	Plow bolt 7/16" NC x 1 1/2" lg + nut & lock washer	5	6
3	110-05541	Skid shoe (right side)	1	1
4	8112	Lock pin 1/4"	2	2
5	140-03261	Skid shoes lock	2	2
6	300-40430	Bolt 1/2" NC x 3 1/2" lg + nylon locknut	2	2
7	6520	Storage support	1	1
8	300-36550	Bolt 3/8" NC x 5 1/2" lg + nylon locknut	4	4
9	6521	Storage support pin	1	1
10	6451	Gear box T281	1	1
11	Std.	Hitch pin clip 5/32"	4	4
12	6522	Adjustment plate for gear box + 4 nuts 3/8" NC	1	1
13	140-20371	3-point side bar	2	2
14	110-36772	Right lower hitch	1	1
15	300-40460	Bolt 1/2" NC x 4" lg + nylon locknut	2	2
16	6253	Pin category 1	2	2
17	6408-E	P.T.O. shaft	1	1
18	110-33871	Upper hitch	1	1
19	6466	Splined adaptor 1 1/4"-19	1	1
20	110-07883	Auger drive shaft 20 7/8" lg overall (including no. 19 & 26)	1	-
20	110-07893	Auger drive shaft 24 7/8" lg overall (including no. 19 & 26)	-	1
21	300-46370	Bolt 3/4" NC x 2 1/2" lg + nylon locknut	1	1
22	300-32340	Bolt 1/4" NC x 2" lg grade 5 + nylon locknut	1	1
23	160-26501	Bushing 1 1/4" i.d. x 1 1/2" o.d. x 5/8" lg	1	1
24	110-07413	Sprocket #50 + shearplate (including # 23, 25 and 26)	1	1
25	160-26511	Bushing 1 1/4" i.d. x 1 1/2" o.d. x 13/32" lg	1	1
26	Std.	Grease fitting 1/4"-28 straight	5	5
27	UCFLD205-16	Bearing 1" + flange	3	3
28	190-01422	Chain #50 x 58 1/8" lg	1	1
28	26A50	Connecting link no. 50	1	1
28	59-50	Offset link no. 50 (if required)	1	1
29	110-04361	Skid shoe (left side)	1	1
30	120-03487	Frame P-540	1	-
30	120-03507	Frame P-620	-	1
31	150-00462	Idler clevis pin	1	1
32	6604	Idler sprocket #50	2	2
33	160-01612	Spacer	2	2
34	110-01972	Idler	1	1
35	110-01991	Threaded rod for idler adjustment + nut 7/16" NC	1	1
36	110-01981	Threaded tube for idler adjustment	1	1
37	6538	Compression spring	1	1
38	300-36250	Bolt 3/8" NC x 1" lg + nylon locknut	2	2
39	300-40280	Bolt 1/2" NC x 1 1/4" lg + nylon locknut thin + washer 7/16"	6	6
40	376-40000	Flat washer 1/2"	1	1
41	346-41000	Nylon locknut 1/2" NC thin	1	1
42	Std.	Roll pin 5/16" x 2" lg	4	4
43	110-21291	Chain guard cover	1	-
43	110-21301	Chain guard cover	-	1
44	8374	Adjustable clamp fastener (welded)	1	1
45	110-02233	Chain guard	1	1
46	300-40340	Bolt 1/2" NC x 2" lg + nylon locknut	4	4
47	Std.	Cotter pin 5/32" x 2" lg (2)	opt.	opt.
48	6438	Chute adjusting rod (1)	opt.	opt.
49	6439	Chute adjusting tube (1)	opt.	opt.
50	8112	Lock pin 1/4" (1)	opt.	opt.
51	346-34000	Nylon locknut 5/16" NC (1)	opt.	opt.
52	140-00881	Hoses mounting plate (1)	opt.	opt.
53	110-01121	Mounting support plate (1)	opt.	opt.
54	Std.	Cotter pin 1/8" x 1" lg (1)	opt.	opt.
55	FLD205	Flange	3	3
56	UC205-16	Bearing 1"	3	3

SNOWBLOWERS P-540 P-620 (cont'd)

REF.	PART #	DESCRIPTION	QTY	
			P-540	P-620
57	300-36280	Bolt 3/8" NC x 1 1/4" lg + two-way locknut	4	4
58	6288	Sprocket 50 A36 T 1" ø	1	1
59	6281	Auger P-540	1	-
59	6282	Auger P-620	-	1
60	120-01503	Chute (for model PSI-5472 see page 33)	opt.	opt.
61	110-02242	Impeller 22" ø 4 blades	1	1
62	300-36250	Impeller cap screw 3/8" NC x 1" lg (ass'd with locktite 242) + lock washer	1	1
63	6471	U-shaped UHMW ± 12" ø i.d.	1	1
64	300-38280	Bolt 7/16" NC x 1 1/4" lg + nylon lock nut & flat washer	2	2
65	110-02001	Retaining bracket	1	1
66	300-34370	Bolt 5/16" NC x 2 1/2" lg + nylon locknut	2	2
67	6276	Square key 1/4" x 1/4" x 1 3/4" lg	1	1
68	110-13361	Hinged P.T.O. shroud	1	1
69	110-33781	Hoses support	1	1
70	300-40490	Bolt 1/2" NC 4 1/2" lg + nylon locknut	2	2
71	300-36250	Bolt 3/8" NC x 1" lg + nylon locknut + flat washer 5/16"	3	3
72	110-36771	Left lower hitch	1	1
73	Std.	Grease fitting 1/4"-28 90 deg.	2	2
74	130-15452	Interior guard (welded)	1	1
75	300-36250	Bolt 3/8" NC x 1" lg + nylon locknut & flat washer	4	4
76	130-15431	Interior guard (bolted)	1	1
77	300-32280	Bolt 1/4" NC x 1 1/4" lg + nylon locknut	2	2
78	140-11101	Back plate	3	3
79	150-06012	Pin for 3 point hitch (top link)	1	1

SNOWBLOWERS P-680 P-720

170-04395

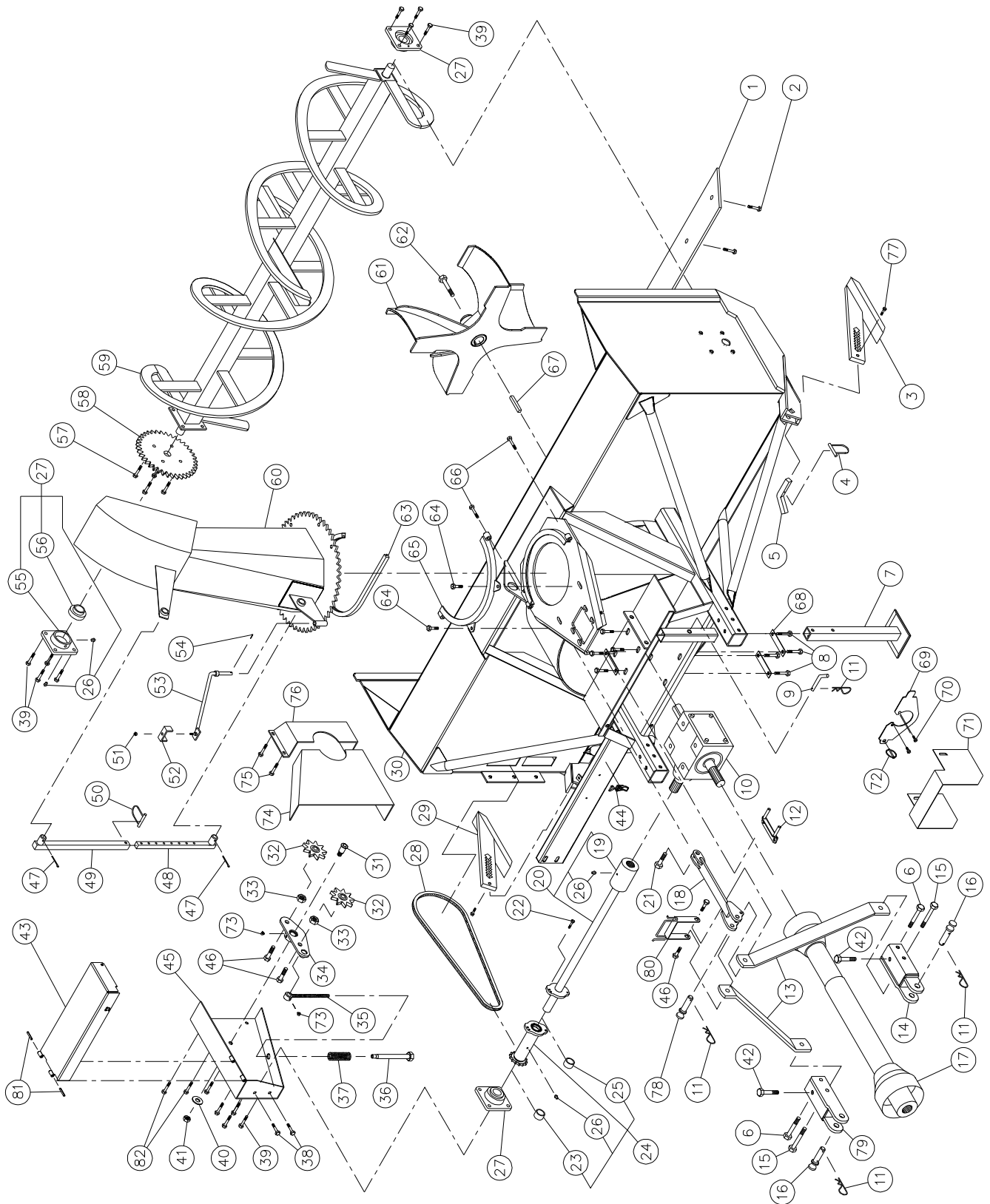

SNOWBLOWERS P-680 P-720 (cont'd)

REF.	PART #	DESCRIPTION	QTY	
			P-680	P-720
1	140-01271	Scraper blade (not reversible) 3/8" x 2 1/2" x 76 1/4" lg	1	-
1	140-01281	Scraper blade (not reversible) 3/8" x 2 1/2" x 68 1/4" lg	-	1
2	319-38310	Plow bolt 7/16" NC x 1 1/2" lg + nut & lock washer	7	7
3	110-05541	Skid shoe (right side)	1	1
4	8112	Lock pin 1/4"	2	2
5	140-03261	Skid shoes lock	2	2
6	300-40460	Bolt 1/2" NC x 4" lg + nylon locknut	2	2
7	6520	Storage support	1	1
8	300-40280	Bolt 1/2" NC x 1 1/4" lg + lock washer	8	8
9	6521	Storage support pin	1	1
10	8251	Gear box T27D	1	1
11	Std.	Hitch pin clip 5/32"	4	4
12	8199	Adjustment plate for gear box + 4 nuts 1/2" NC	1	1
13	140-20281	3-point side bar	2	2
14	110-36772	Right lower hitch	1	1
15	300-40490	Bolt 1/2" NC x 4 1/2" lg + nylon locknut	2	2
16	6253	Pin category 1	2	2
17	6248-EG	P.T.O. shaft	1	-
17	8114-EG	P.T.O. shaft	-	1
18	110-28862	Upper hitch	1	1
19	6466	Splined adaptor 1 1/4"-19	1	1
20	110-07904	Auger drive shaft 24 7/16" lg overall (including no. 19 & 26)	1	-
20	110-07914	Auger drive shaft 26 7/16" lg overall (including no. 19 & 26)	-	1
21	302-46370	Bolt 3/4" NC x 2 1/2" lg + nylon locknut	1	1
22	300-32340	Bolt 1/4" NC x 2" lg grade 5 + nylon locknut	1	1
23	160-26501	Bushing 1 1/4" i.d. x 1 1/2" o.d. x 5/8" lg	1	1
24	110-44352	Sprocket #60 + shearplate (including #23,25 &26)	1	1
25	160-26511	Bushing 1 1/4" i.d. x 1 1/2" o.d. x 13/32" lg	1	1
26	Std.	Grease fitting 1/4"-28 straight	8	8
27	UCFD207-20	Bearing 1 1/4" + flange + 2 grease fitting (straight)	3	3
28	190-04702	Chain #60 x 68 1/4" lg	1	1
28	26A60	Connecting link no. 60	1	1
28	59-60	Offset link no. 60 (if required)	1	1
29	110-04361	Skid shoe (left side)	1	1
30	120-03527	Frame P-680	1	-
30	120-03547	Frame P-720	-	1
31	150-00332	Idler clevis pin	1	1
32	8186	Idler sprocket #60	2	2
33	336-44000	Nut 5/8" NC	2	2
34	110-16361	Idler	1	1
35	110-16321	Threaded rod for idler adjustment + nut 7/16" NC	1	1
36	110-01981	Threaded tube for idler adjustment	1	1
37	9473	Compression spring	1	1
38	300-36250	Bolt 3/8" NC x 1" lg + nylon locknut	2	2
39	300-40325	Bolt 1/2" NC x 1 3/4" lg + nylon locknut thin + washer 7/16"	12	12
40	376-44000	Flat washer 5/8"	1	1
41	346-45000	Nylon locknut 5/8" NC thin	1	1
42	300-40430	Bolt 1/2" NC x 3 1/2" lg + nylon locknut	2	2
43	110-21311	Chain guard cover	1	-
43	110-21321	Chain guard cover	-	1
44	8374	Adjustable clamp fastener (welded)	1	1
45	110-18952	Chain guard	1	1
46	300-40340	Bolt 1/2" NC x 2" lg + nylon locknut	4	4
47	Std.	Cotter pin 5/32" x 2" lg (2)	opt.	opt.
48	6438	Chute adjusting rod (1)	opt.	opt.
49	6439	Chute adjusting tube (1)	opt.	opt.
50	8112	Lock pin 1/4" (1)	opt.	opt.
51	Std.	Nylon locknut 5/16" NC (1)	opt.	opt.
52	140-00881	Hoses mounting plate (1)	opt.	opt.
53	110-01121	Mounting support plate (1)	opt.	opt.
54	Std.	Cotter pin 1/8" x 1" lg (1)	opt.	opt.

SNOWBLOWERS P-680 P-720 (cont'd)

REF.	PART #	DESCRIPTION	QTY	
			P-680	P-720
55	FD207	Flange for two grease fittings	3	3
56	UC207-20	Bearing 1 1/4"	3	3
57	300-38310	Bolt 7/16" NC x 1 1/2" lg + two-way locknut	4	4
58	8021	Sprocket 60 A38 T 1 1/4" ø	1	1
59	110-18842	Auger P-680	1	-
59	110-18872	Auger P-720	-	1
60	120-01503	Chute (1) (for model PSIG-5472 see page 33)	opt.	opt.
61	110-18991	Impeller 24" ø 4 blades	1	1
62	300-44310	Impeller cap screw 5/8" NC x 1 1/2" lg (ass'd with locktite 242) + lock washer	1	1
63	6471	U-shaped UHMW ± 12" ø i.d.	1	1
64	300-38280	Bolt 7/16" NC x 1 1/4" lg + nylon lock nut & flat washer	2	2
65	110-02001	Retaining bracket	1	1
66	300-34370	Bolt 5/16" NC x 2 1/2" lg + nylon locknut	2	2
67	8030	Square key 3/8" x 3/8" x 3 1/2" lg	1	1
68	140-10571	Back plate	3	3
69	130-15522	Mounting plate for shroud	1	1
70	300-32016	Bolt M8 x 1.25 x 16 mm lg + lock washer	2	2
71	130-15501	Hinged P.T.O. shroud	1	1
72	Std.	Linch pin 1/4" x 1 3/4" lg	1	1
73	Std.	Grease fitting 1/4"-28 90 deg.	2	2
74	130-19432	Interior guard (welded) (from serial # 17011)	1	1
75	300-36250	Bolt 3/8" NC x 1" lg + nylon locknut & flat washer	4	4
76	130-27661	Interior guard (bolted) (from serial # 17011)	1	1
77	300-32280	Bolt 1/4" NC x 1 1/4" lg + nylon locknut	2	2
78	150-06012	Pin for 3 point hitch (top link)	1	1
79	110-36771	Left lower hitch	1	1
80	110-33781	Hoses support	1	1
81	Std.	Spring pin 5/16" x 2"	2	2
82	300-36250	Bolt 3/8" NC x 1" lg + nylon locknut + flat washer 5/16"	3	3

SNOWBLOWERS P-680TRC P-720TRC

170-05393

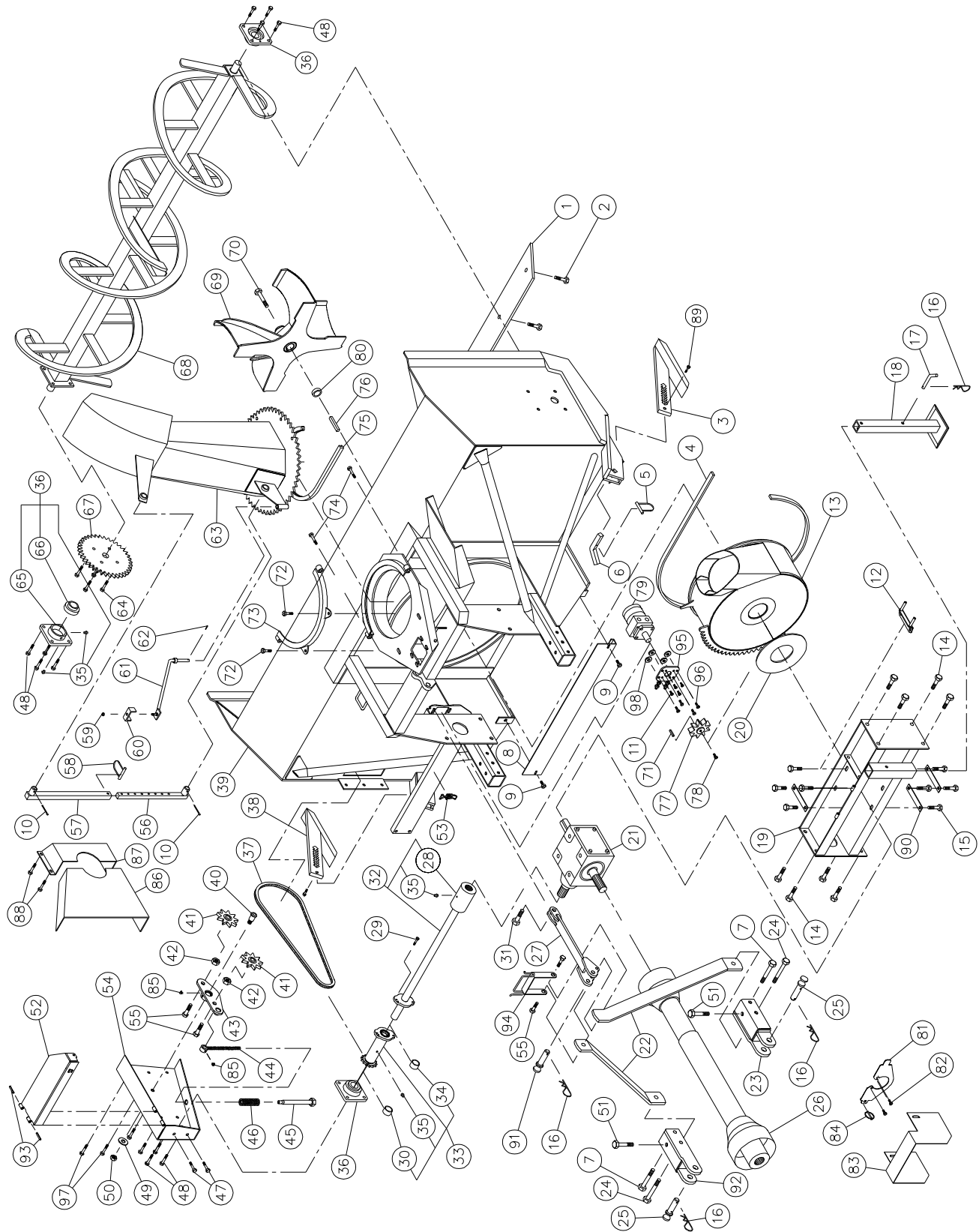

10

SNOWBLOWERS P-680TRC P-720TRC (cont'd)

REF.	PART #	DESCRIPTION	QTY	
			P-680TRC	P-720TRC
1	140-01271	Scraper blade (not reversible) 3/8" x 2 1/2" x 64 1/4" lg	1	-
1	140-01281	Scraper blade (not reversible) 3/8" x 2 1/2" x 68 1/4" lg	-	1
2	319-38310	Plow bolt 7/16" NC x 1 1/2" lg + nut & lock washer	7	7
3	110-05541	Skid shoe (right side)	1	1
4	6515	U-shaped UHMW 3/8" x 9/16" x 77" lg	1	1
5	8112	Lock pin 1/4"	2	2
6	140-03261	Skid shoes lock	2	2
7	300-40460	Bolt 1/2" NC x 4" lg + nylon locknut	2	2
8	130-03231	Guard for ring gear segment	1	1
9	300-38250	Bolt 7/16" NC x 1" lg + nylon locknut & flat washer	2	2
10	Std.	Cotter pin 5/32" x 2" lg (2)	opt.	opt.
11	300-36250	Bolt 3/8" NC x 1" lg + lockwasher	4	4
12	8199	Adjustment plate for gear box + 4 nuts 1/2" NC	1	1
13	110-21173	Rotary drum 24" ø	1	1
14	300-40280	Bolt 1/2" NC x 1 1/4" lg + nylon locknut	8	8
15	300-40280	Bolt 1/2" NC x 1 1/4" lg + lock washer	8	8
16	Std.	Hitch pin clip 5/32"	4	4
17	6521	Storage support pin	1	1
18	6520	Storage support	1	1
19	110-05601	Gear box support	1	1
20	8232	UHMW flat washer 3/16" x 4 5/8" i.d. x 8 1/8" o.d.	1	1
21	8251	Gear box T-27D	1	1
22	140-20531	3-point side bar	2	2
23	110-36772	Right lower hitch	1	1
24	300-40490	Bolt 1/2" NC x 4 1/2" lg + nylon locknut	1	1
25	6253	Pin category 1	2	2
26	6248-EG	P.T.O. shaft	1	-
26	8114-EG	P.T.O. shaft	-	1
27	110-28842	Upper hitch	1	1
28	6466	Splines adaptor 1 1/4" - 19	1	1
29	300-32340	Safety shear bolt 1/4" NC x 2" lg grade 5 + nylon locknut	1	1
30	160-26501	Bushing 1 1/4" i.d. x 1 1/2" o.d. x 5/8" lg	1	1
31	302-46370	Bolt 3/4" NC x 2 1/2" lg + nylon locknut	1	1
32	110-07904	Auger drive shaft 24 7/16" lg overall (including no. 28 & 35)	1	-
32	110-07914	Auger drive shaft 26 7/16" lg overall (including no. 28 & 35)	-	1
33	110-44352	Sprocket #60 + shearplate (including # 30, 34 & 35)	1	1
34	160-26511	Bushing 1 1/4" i.d. x 1 1/2" o.d. x 13/32" lg	1	1
35	Std.	Grease fitting 1/4"-28 straight	8	8
36	UCFD207-20	Bearing 1 1/4" + flange & two grease fittings (straight)	3	3
37	190-00581	Chain #60 x 69 3/4"	1	1
37	26A60	Connecting link no. 60	1	1
37	59-60	Offset link no. 60 (if required)	1	1
38	110-04361	Skid shoe (left side)	1	1
39	120-03606	Frame P-680TRC	1	-
39	120-03626	Frame P-720TRC	-	1
40	150-00332	Idler clevis pin	1	1
41	8186	Idler sprocket #60	2	2
42	336-44000	Nut 5/8" NC	2	2
43	110-16361	Idler	1	1
44	110-16321	Threaded rod for idler adjustment + nut 7/16" NC	1	1
45	110-01981	Threaded tube for idler adjustment	1	1
46	9473	Compression spring	1	1
47	300-36250	Bolt 3/8" NC x 1" lg + nylon locknut	2	2
48	300-40325	Bolt 1/2" NC x 1 3/4" lg + nylon locknut + flat washer 7/16"	12	12
49	376-44000	Flat washer 5/8"	1	1
50	346-45000	Nylon locknut 5/8" NC thin	1	1

SNOWBLOWERS P-680TRC P-720TRC (cont'd)

REF.	PART #	DESCRIPTION	QTY	
			P-680TRC	P-720TRC
51	300-40340	Bolt 1/2" NC x 3 1/2" lg + nylon locknut	2	2
52	110-34201	Chain guard cover	1	-
52	110-34211	Chain guard cover	-	1
53	8374	Adjustable clamp fastener (welded)	1	1
54	110-18952	Chain guard	1	1
55	300-40340	Bolt 1/2" NC x 2" lg + nylon locknut	4	4
56	6438	Chute adjusting rod (1)	opt.	opt.
57	6439	Chute adjusting tube (1)	opt.	opt.
58	8112	Lock pin (1)	opt.	opt.
59	346-34000	Nylon locknut 5/16" NC (1)	opt.	opt.
60	140-00881	Hoses mounting plate (1)	opt.	opt.
61	110-01121	Mounting support plate (1)	opt.	opt.
62	Std.	Cotter pin 1/8" x 1" lg (1)	opt.	opt.
63	120-01503	Chute (1) (for model PSIG-5472 see page 33)	opt.	opt.
64	300-38310	Bolt 7/16" NC x 1 1/2" lg + two-way locknut	4	4
65	FD207	Flange for two grease fittings	3	3
66	UC207-20	Bearing 1 1/4"	3	3
67	8021	Sprocket #60A30 T 1 1/4"	1	1
68	110-18842	Auger P-680TRC	1	-
68	110-18872	Auger P-720TRC	-	1
69	110-18991	Impeller 24" ø 4 blades	1	1
70	300-44340	Impeller cap screw 5/8" NC x 2" lg (ass'd with locktite 242) + lock washer	1	1
71	8369	Key	1	1
72	300-38280	Bolt 7/16" NC x 1 1/4" lg + nylon locknut & flat washer	2	2
73	110-02001	Retaining bracket	1	1
74	300-34370	Bolt 5/16" NC x 2 1/2" lg + nylon locknut	2	2
75	6471	U-shaped UHMW ± 12" i.d.	1	1
76	8030	Square key 3/8" x 3/8" x 3 1/2" lg	1	1
77	110-44331	Sprocket (9 teeth)	1	1
78	300-32220	Bolt 1/4" NC x 3/4" lg + lock washer	1	1
79	MLH100	Hydraulic motor for rotary drum	1	1
80	6622	Spacer 1 1/4" o.d. x 3/4" i.d. x 9/16" lg	1	1
81	130-15522	Mounting plate for shroud	1	1
82	300-32016	Bolt M8 x 1.25 x 16 mm lg + lock washer	2	2
83	130-15511	Hinged P.T.O. shroud	1	1
84	Std.	Linch pin 1/4" x 1 3/4" lg	1	1
85	Std.	Grease fitting 1/4"-28 90 deg.	2	2
86	130-19432	Interior guard (welded)	1	1
87	130-27661	Interior guard (bolted)	1	1
88	300-36250	Bolt 3/8" NC x 1" lg + nylon locknut & flat washer	4	4
89	300-32280	Bolt 1/4" NC x 1 1/4" lg + nylon locknut	2	2
90	140-10571	Back plate	3	3
91	150-06012	Pin for 3 point hitch (top link)	1	1
92	110-36771	Left lower hitch	1	1
93	Std.	Spring pin 5/16" x 2" lg	2	2
94	110-33781	Hoses support	1	1
95	110-18441	Adjustment plate for motor + 4 nuts 7/16" NC	1	1
96	300-38310	Bolt 7/16" NC x 1 1/2" lg + nylon locknut	4	4
97	300-36250	Bolt 3/8" NC x 1" lg + nylon locknut + flat washer 5/16"	3	3
98	150-12741	Flat washer 7/16" heavy-duty	4	4

SNOWBLOWERS P-720-74 P-720-80

170-03965R1

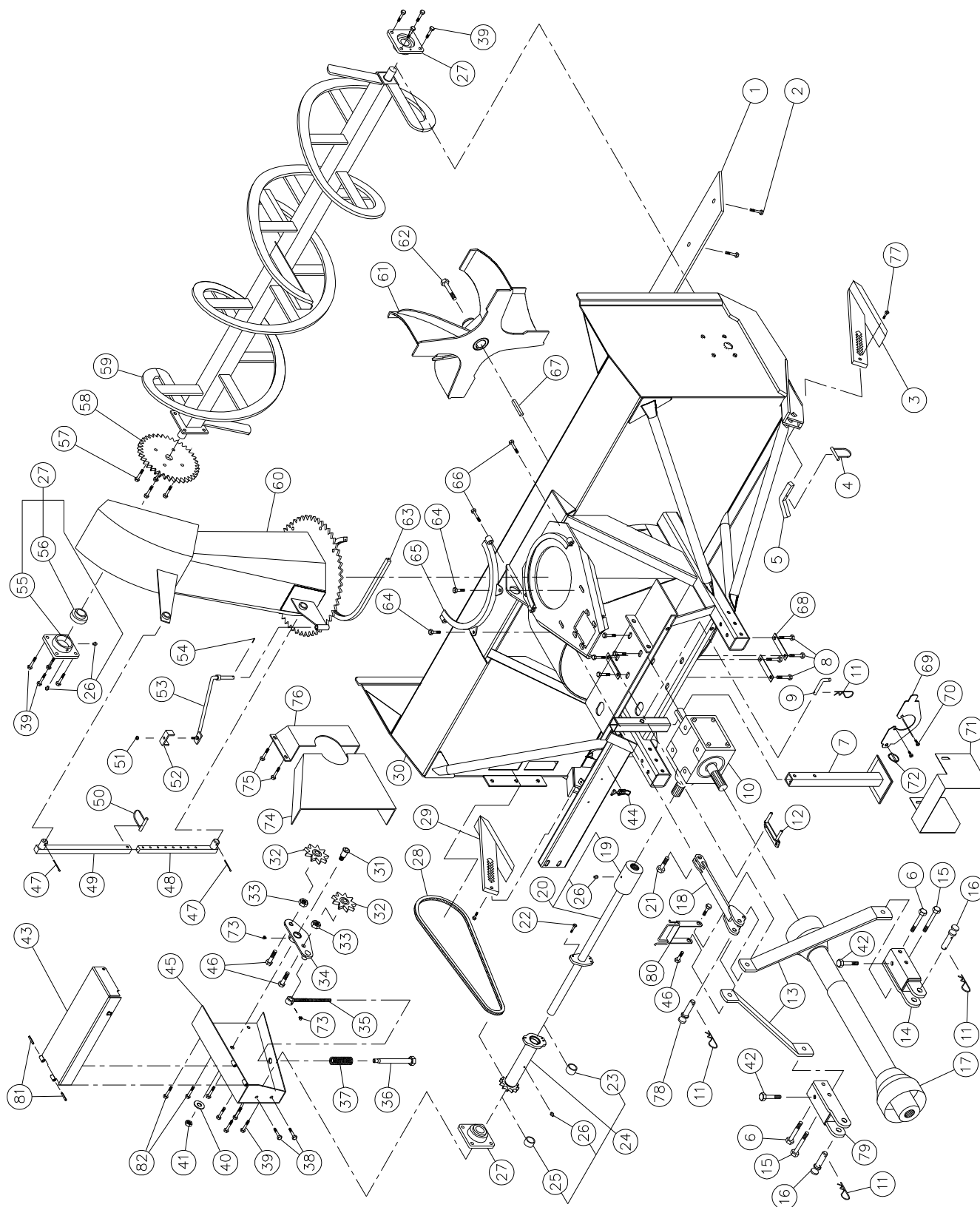

SNOWBLOWERS P-720-74 P-720-80 (cont'd)

REF.	PART #	DESCRIPTION	QTY	
			P-720-74	P-720-80
1	140-11181	Scraper blade (not reversible) 3/8" x 2 1/2" x 70 3/4" lg	1	-
1	140-14131	Scraper blade (not reversible) 3/8" x 2 1/2" x 70 3/4" lg	-	1
2	319-38310	Plow bolt 7/16" NC x 1 1/2" lg + nut & lock washer	7	8
3	110-05541	Skid shoe (right side)	1	1
4	8112	Lock pin 1/4"	2	2
5	140-03261	Skid shoes lock	2	2
6	300-40460	Bolt 1/2" NC x 4" lg + nylon locknut	2	2
7	6520	Storage support	1	1
8	300-40280	Bolt 1/2" NC x 1 1/4" lg + lock washer	8	8
9	6521	Storage support pin	1	1
10	8251	Gear box T27D	1	1
11	Std.	Hitch pin clip 5/32"	4	4
12	8199	Adjustment plate for gear box + 4 nuts 1/2" NC	1	1
13	140-17432	3-point side bar	2	2
14	110-36772	Right lower hitch	1	1
15	300-40490	Bolt 1/2" NC x 4 1/2" lg + nylon locknut	2	2
16	6253	Pin category 1	2	2
17	8114-EG	P.T.O. shaft	1	1
18	110-28862	Upper hitch	1	1
19	6466	Splined adaptor 1 1/4"-19	1	1
20	110-16333	Auger drive shaft 27 9/16" lg overall (including no. 19 & 26)	1	-
20	110-22803	Auger drive shaft 30 9/16" lg overall (including no. 19 & 26)	-	1
21	302-46370	Bolt 3/4" NC x 2 1/2" lg + nylon locknut	1	1
22	300-32340	Bolt 1/4" NC x 2" lg grade 5 + nylon locknut	1	1
23	160-26511	Bushing 1 1/4" i.d. x 1 1/2" o.d. x 7/16" lg	1	1
24	110-44352	Sprocket #60 + shearplate	1	1
25	160-26501	Brass bushing 1 1/4" i.d. x 1 1/2" o.d. x 5/8" lg	1	1
26	Std.	Grease fitting 1/4"-28 straight	8	8
27	UCFD207-20	Bearing 1 1/4" + flange + 2 grease fitting (straight)	3	3
28	190-00581	Chain #60 x 69 3/4" lg	1	1
28	26A60	Connecting link no. 60	1	1
28	59-60	Offset link no. 60 (if required)	1	1
29	110-04361	Skid shoe (left side)	1	1
30	120-04116	Frame P-720-74	1	-
30	120-04575	Frame P-720-80	-	1
31	150-00332	Idler clevis pin	1	1
32	8186	Idler sprocket #60	2	2
33	336-44000	Nut 5/8" NC	2	2
34	110-16361	Idler	1	1
35	110-16321	Threaded rod for idler adjustment + nut 7/16" NC	1	1
36	110-01981	Threaded tube for idler adjustment	1	1
37	6538	Compression spring	1	1
38	300-36250	Bolt 3/8" NC x 1" lg + nylon locknut	4	4
39	300-40325	Bolt 1/2" NC x 1 3/4" lg + nylon locknut + flat washer 7/16"	12	12
40	376-44000	Flat washer 5/8"	1	1
41	346-45000	Nylon locknut 5/8" NC thin	1	1
42	300-40430	Bolt 1/2" NC x 3 1/2" lg + nylon locknut	2	2
43	110-21321	Chain guard cover	1	-
43	110-22812	Chain guard cover	-	1
44	8374	Adjustable clamp fastener (welded)	1	1
45	110-18952	Chain guard	1	1
46	300-40340	Bolt 1/2" NC x 2" lg + nylon locknut	4	4
47	Std.	Cotter pin 5/32" x 2" lg (2)	opt.	opt.
48	6438	Chute adjusting rod (1)	opt.	opt.
49	6439	Chute adjusting tube (1)	opt.	opt.
50	8112	Lock pin 1/4" (1)	opt.	opt.
51	Std.	Nylon locknut 5/16" NC (1)	opt.	opt.
52	140-00881	Hoses mounting plate (1)	opt.	opt.

SNOWBLOWERS P-720-74 P-720-80 (cont'd)

REF.	PART #	DESCRIPTION	QTY	
			P-720-74	P-720-80
53	110-01121	Mounting support plate (1)	opt.	opt.
54	Std.	Cotter pin 1/8" x 1" lg (1)	opt.	opt.
55	FD207	Flange for two grease fittings	3	3
56	UC207-20	Bearing 1 1/4"	3	3
57	300-38310	Bolt 7/16" NC x 1 1/2" lg + two-way locknut	4	4
58	8021	Sprocket 60 A38 T 1 1/4" ø	1	1
59	110-19002	Auger P-720-74	1	-
59	110-22822	Auger P-720-80	-	1
60	120-01503	Chute (1) (for model PSIG-5472 see page 33)	opt.	opt.
61	110-28831	Impeller 26" ø 4 blades	1	1
62	300-44310	Impeller cap screw 5/8" NC x 1 1/2" lg (ass'd with locktite 242) + lock washer	1	1
63	6471	U-shaped UHMW ± 12" ø i.d.	1	1
64	300-38280	Bolt 7/16" NC x 1 1/4" lg + nylon lock nut & flat washer	2	2
65	110-02001	Retaining bracket	1	1
66	300-34370	Bolt 5/16" NC x 2 1/2" lg + nylon locknut	2	2
67	8030	Square key 3/8" x 3/8" x 3 1/2" lg	1	1
68	140-10571	Back plate	3	3
69	130-15522	Mounting plate for shroud	1	1
70	300-32016	Bolt M8 x 1.25 x 16 mm lg + lock washer	2	2
71	130-15501	Hinged P.T.O. shroud	1	1
72	Std.	Linch pin 1/4" x 1 3/4" lg	1	1
73	Std.	Grease fitting 1/4"-28 90 deg.	2	2
74	130-19432	Interior guard (welded) (from serial # 17011)	1	1
75	300-36250	Bolt 3/8" NC x 1" lg + nylon locknut & flat washer	4	4
76	130-27661	Interior guard (bolted) (from serial # 17011)	1	1
77	300-32280	Bolt 1/4" NC x 1 1/4" lg + nylon locknut	2	2
78	150-06012	Pin for 3 point hitch (top link)	1	1
79	110-36771	Left lower hitch	1	1
80	110-33781	Hoses support	1	1
81	Std.	Spring pin 5/16" x 2"	2	2
82	300-36250	Bolt 3/8" NC x 1" lg + nylon locknut + flat washer 5/16"	3	3

SNOWBLOWERS P-720TRC-74 P-720TRC-80

170-05063R1

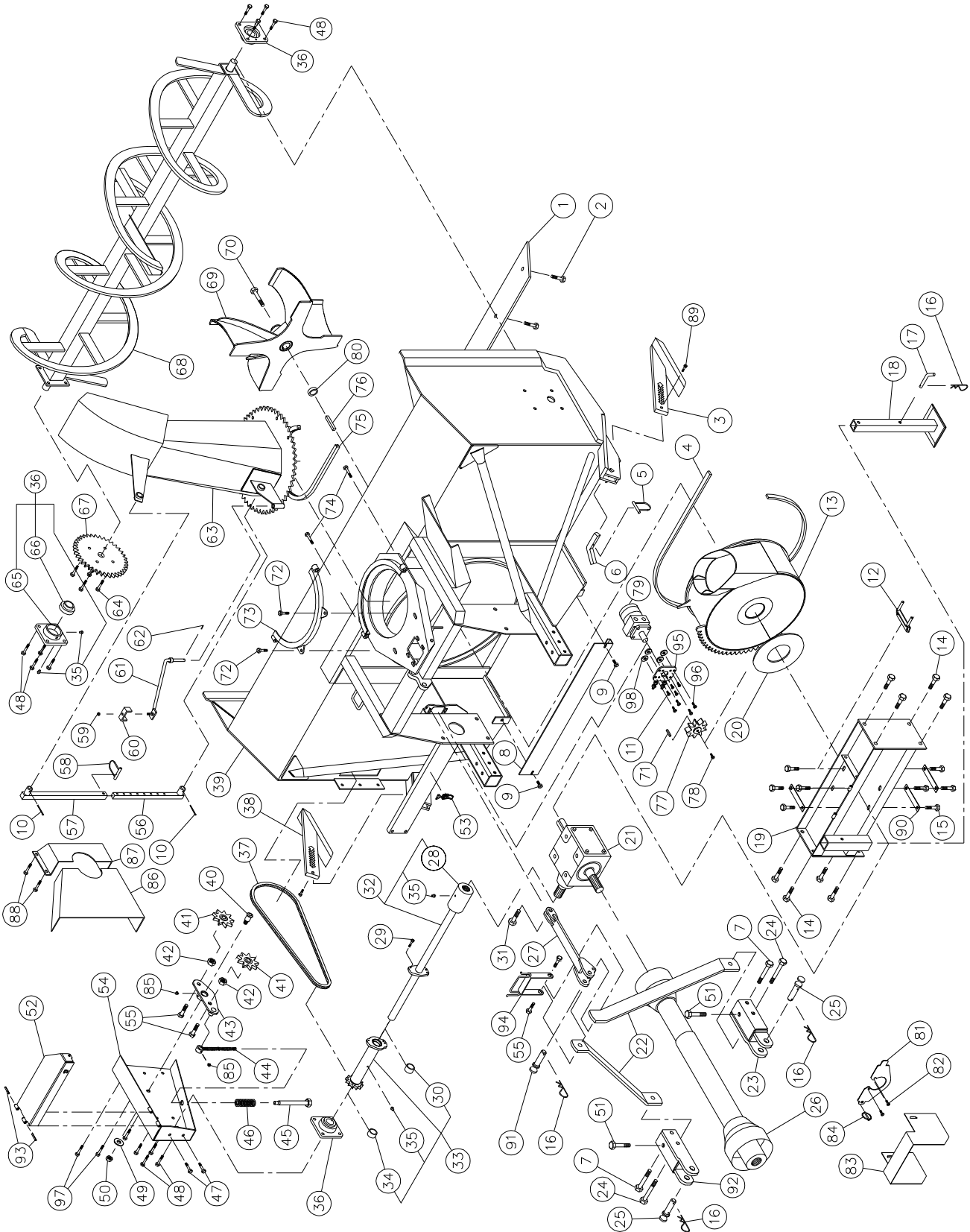

10

SNOWBLOWERS P-720TRC-74 P-720TRC-80 (cont'd)

REF.	PART #	DESCRIPTION	QTY	
			74	80
1	140-11181	Scraper blade (not reversible) 3/8" x 2 1/2" x 70 1/4" lg	1	-
1	140-14131	Scraper blade (not reversible) 3/8" x 2 1/2" x 76 1/4" lg	-	1
2	319-38310	Plow bolt 7/16" NC x 1 1/2" lg + nut & lock washer	7	8
3	110-05541	Skid shoe (right side)	1	1
4	190-11241	U-shaped UHMW 3/8" x 5/8" x 83 3/8" lg	1	1
5	8112	Lock pin 1/4"	2	2
6	140-03261	Skid shoes lock	2	2
7	300-40460	Bolt 1/2" NC x 4" lg + nylon locknut	2	2
8	130-72911	Guard for ring gear segment	1	1
9	300-38250	Bolt 7/16" NC x 1" lg + nylon locknut & flat washer	2	2
10	Std.	Cotter pin 5/32" x 2" lg (2)	opt.	opt.
11	300-36250	Bolt 3/8" NC x 1" lg + lock washer	4	4
12	8199	Adjustment plate for gear box + 4 nuts 1/2" NC	1	1
13	110-40391	Rotary drum 26" ø	1	1
14	300-40280	Bolt 1/2" NC x 1 1/4" lg + nylon locknut	8	8
15	300-40280	Bolt 1/2" NC x 1 1/4" lg + lock washer	8	8
16	Std.	Hitch pin clip 5/32"	4	4
17	6521	Storage support pin	1	1
18	6520	Storage support	1	1
19	110-40501	Gear box support	1	1
20	8232	UHMW flat washer 3/16" x 4 5/8" i.d. x 8 1/8" o.d.	1	1
21	8251	Gear box T-27D	1	1
22	140-23871	3-point side bar	2	2
23	110-36772	Right lower hitch	1	1
24	300-40490	Bolt 1/2" NC x 4 1/2" lg + nylon locknut	2	2
25	6253	Pin category 1	2	2
26	8114-EG	P.T.O. shaft	1	1
27	110-40561	Upper hitch	1	1
28	6466	Splines adaptor 1 1/4" - 19	1	1
29	300-32340	Safety shear bolt 1/4" NC x 2" lg grade 5 + nylon locknut	1	1
30	160-26511	Bushing 1 1/4" i.d. x 1 1/2" o.d. x 7/16" lg	1	1
31	300-46370	Bolt 3/4" NC x 2 1/2" lg + nylon locknut	1	1
32	110-16333	Auger drive shaft 27 5/16" lg overall (including no. 28 & 35)	1	-
32	110-22803	Auger drive shaft 30 5/16" lg overall (including no. 28 & 35)	-	1
33	110-44352	Sprocket #60 + shearplate (including # 30, 34 and 35)	1	1
34	160-26501	Bushing 1 1/4" i.d. x 1 1/2" o.d. x 5/8" lg	1	1
35	Std.	Grease fitting 1/4"-28 straight	8	8
36	UCFD207-20	Bearing 1 1/4" + flange & two grease fittings (straight)	3	3
37	190-00581	Chain #60 x 69 3/4" lg	1	1
37	26A60	Connecting link no. 60	1	1
37	59-60	Offset link no. 60 (if required)	1	1
38	110-04361	Skid shoe (left side)	1	1
39	120-07082	Frame P-720-74TRC	1	-
39	120-07162	Frame P-720-80TRC	-	1
40	150-00332	Idler clevis pin	1	1
41	8186	Idler sprocket #60	2	2
42	336-44000	Nut 5/8" NC	2	2
43	110-16361	Idler	1	1
44	110-16321	Threaded rod for idler adjustment + nut 7/16" NC	1	1
45	110-01981	Threaded rod for idler adjustment	1	1
46	9473	Compression spring	1	1
47	300-36250	Bolt 3/8" NC x 1" lg + nylon locknut	2	2
48	300-40325	Bolt 1/2" NC x 1 3/4" lg + nylon locknut + flat washer 7/16"	12	12
49	376-44000	Flat washer 5/8"	1	1
50	346-45000	Nylon locknut 5/8" NC thin	1	1

SNOWBLOWERS P-720TRC-74 P-720TRC-80 (cont'd)

REF.	PART #	DESCRIPTION	QTY	
			.74	.80
51	300-40430	Bolt 1/2" NC x 3 1/2" lg + nylon locknut	2	2
52	110-40541	Chain guard cover P-720-74TRC	1	-
52	110-40581	Chain guard cover P-720-80TRC	-	1
53	8374	Adjustable clamp fastener (welded)	1	1
54	110-21331	Chain guard	1	1
55	300-40340	Bolt 1/2" NC x 2" lg + nylon locknut	4	4
56	6438	Chute adjusting rod (1)	opt.	opt.
57	6439	Chute adjusting tube (1)	opt.	opt.
58	8112	Lock pin (1)	opt.	opt.
59	346-34000	Nylon locknut 5/16" NC (1)	opt.	opt.
60	140-00881	Hoses mounting plate (1)	opt.	opt.
61	110-01121	Mounting support plate (1)	opt.	opt.
62	Std.	Cotter pin 1/8" x 1" lg (1)	opt.	opt.
63	120-01503	Chute (for model PSIG-5472 see p. 37) (1)	opt.	opt.
64	300-38310	Bolt 7/16" NC x 1 1/2" lg + two-way locknut	4	4
65	FD207	Flange for two grease fittings	3	3
66	UC207-20	Bearing 1 1/4"	3	3
67	8021	Sprocket #60A38 T 1 1/4"	1	1
68	110-19002	Auger P-720-74TRC	1	-
68	110-22822	Auger P-720-80TRC	-	1
69	110-28831	Impeller 26" ø 4 blades	1	1
70	300-44340	Impeller cap screw 5/8" NC x 2" lg (ass'd with locktite 242) + lock washer	1	1
71	8369	Key	1	1
72	300-38280	Bolt 7/16" NC x 1 1/4" lg + nylon locknut & flat washer	2	2
73	110-02001	Retaining bracket	1	1
74	300-34370	Bolt 5/16" NC x 2 1/2" lg + nylon locknut	2	2
75	6471	U-shaped UHMW ± 12" i.d.	1	1
76	8030	Square key 3/8" x 3/8" x 3 1/2" lg	1	1
77	110-44331	Sprocket (9 teeth)	1	1
78	300-32220	Bolt 1/4" NC x 3/4" lg + lock washer	1	1
79	MLH-100	Hydraulic motor for rotary drum	1	1
80	6622	Spacer 1 1/4" o.d. x 3/4" i.d. x 9/16" lg	1	1
81	130-15522	Mounting plate for shroud	1	1
82	300-32016	Bolt M8 x 1.25 x 16 mm lg + lock washer	2	2
83	130-15511	Hinged P.T.O. shroud	1	1
84	Std.	Linch pin 1/4" x 1 3/4" lg	1	1
85	Std.	Grease fitting 1/4"-28 90 deg.	2	2
86	130-19432	Interior guard (welded)	1	1
87	130-27661	Interior guard (bolted)	1	1
88	300-36250	Bolt 3/8" NC x 1" lg + nylon locknut & flat washer	4	4
89	300-32280	Bolt 1/4" NC x 1 1/4" lg + nylon locknut	2	2
90	140-10571	Back plate	3	3
91	150-06012	Pin for 3 point hitch (top link)	1	1
92	110-36771	Left lower hitch	1	1
93	Std.	Spring pin 5/16" X 2"	2	2
94	110-33781	Hoses support	1	1
95	110-18441	Adjustment plate for motor + 4 nuts 7/16"	1	1
96	300-38310	Bolt 7/16" NC x 1 1/2" lg + nylon locknut	4	4
97	300-36250	Bolt 3/8" NC x 1" lg + nylon locknut + flat washer 5/16"	3	3
98	150-12741	Flat washer 7/16" heavy-duty	4	4

MANUAL CHUTE KIT MR-4864

170-01293

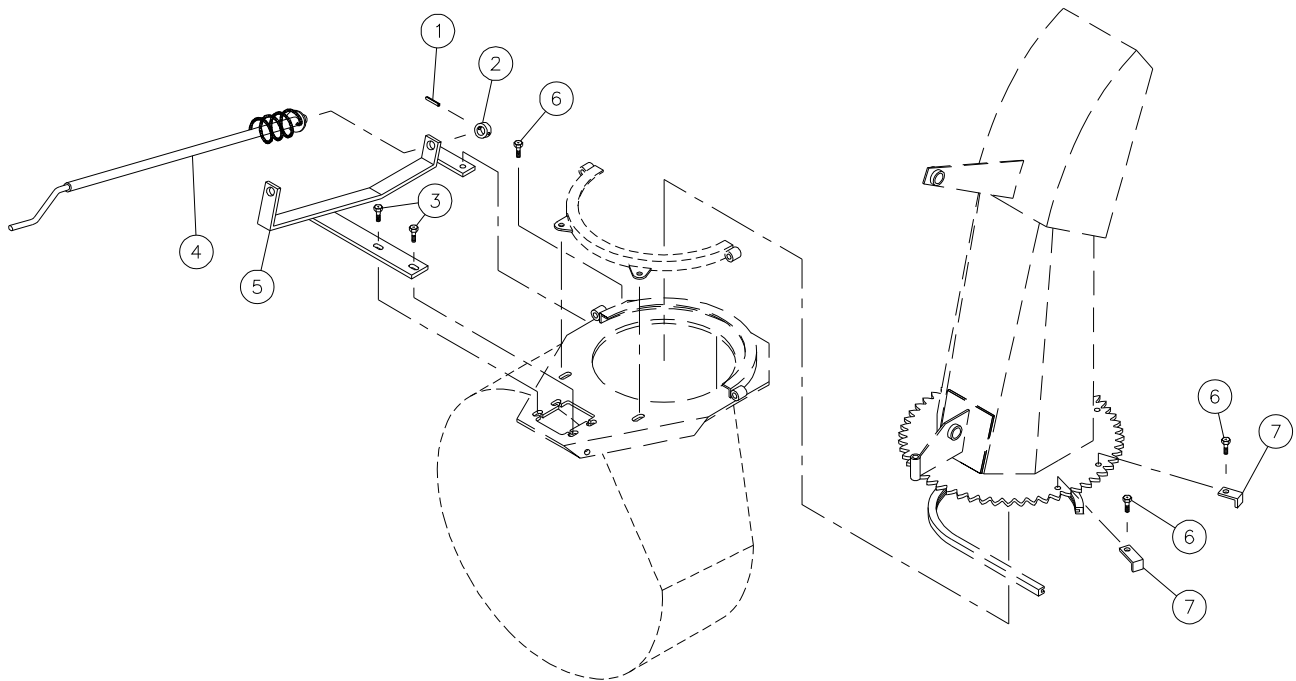

REF.	PART #	DESCRIPTION	QTY
1	Std.	Roll pin 1/4" x 1 1/2"	1
2	130-09091	Crank stopper	1
3	300-38310	Bolt 7/16" NC x 1 1/2" lg + nylon locknut & flat washer	2
4	110-08061	Crank	1
5	110-08071	Crank support	1
6	300-38280	Bolt 7/16" x 1 1/4" lg + nylon locknut	3
7	140-05661	Stopper	2

HYDRAULIC CHUTE KIT *Motor* SP-4864

170-01303

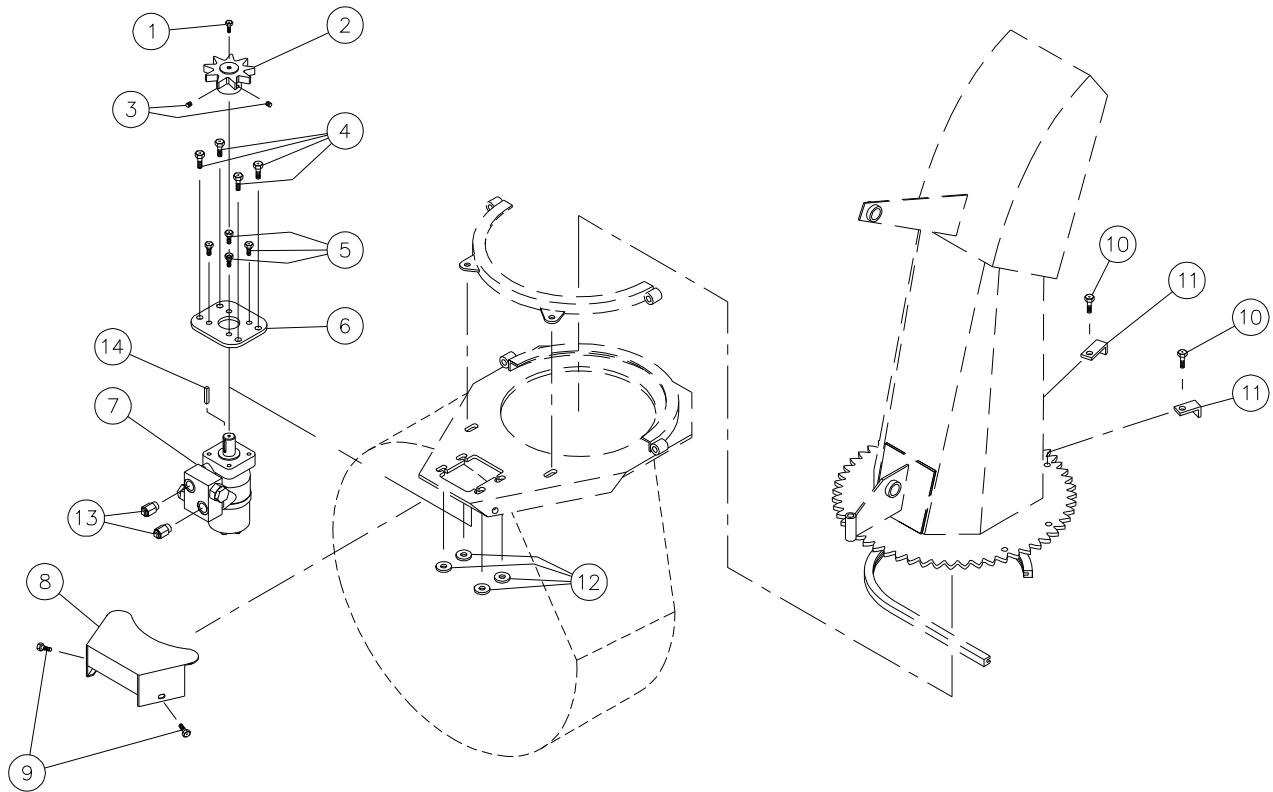

REF.	PART #	DESCRIPTION	QTY
1	300-32220	Bolt 1/4" NC x 3/4" lg + locknut	1
2	110-44331	Sprocket (9 teeth)	1
3	323-36160	Allen set screw 3/8" NC x 3/8" lg	2
4	300-38280	Bolt 7/16" NC x 1 1/2" lg + nylon locknut	4
5	300-36250	Bolt 3/8" NC x 1" lg + lock washer	4
6	130-07911	Motor mounting plate	1
7	MLH125	Hydraulic motor	opt.
7	MLH250	Hydraulic motor	opt.
8	130-08561	Guard	1
9	300-34250	Bolt 5/16" NC x 1" lg + lock washer	2
10	300-38280	Bolt 7/16" NC x 1 1/4" lg + nylon locknut.....	2
11	140-05661	Stopper	2
12	150-12741	Flat washer 7/16" heavy-duty	4
13	RSP-1/16x10 ORB	Kit of two unidirectional restrictors	opt.
14	8369	Key	1

10

SEMI-INDUSTRIAL CHUTE PSIG-5472

170-03513

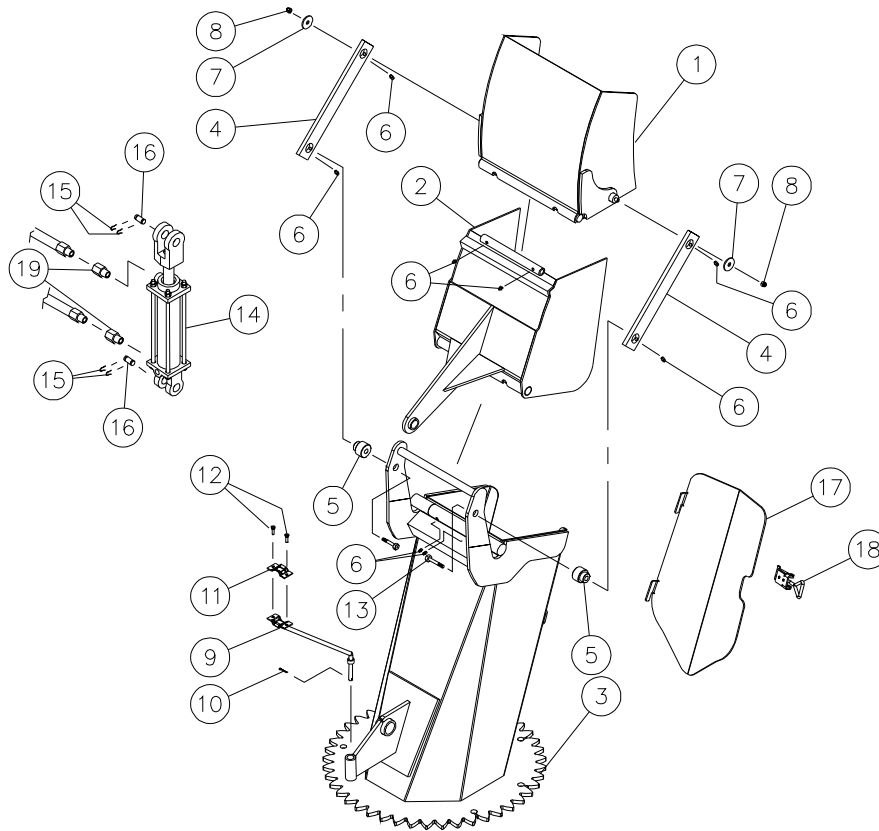

REF.	PART #	DESCRIPTION	QTY
1	110-22861	Upper chute deflector	1
2	110-22871	Lower chute deflector	1
3	110-36763	Chute base	1
4	140-14171	Connecting rod	2
5	150-05391	Spacer for connecting rod	2
6	Std.	Grease fitting 1/4" - 28 droit	8
7	378-36500	washer	2
8	346-36000	Nylon locknut 3/8" NC	2
9	110-01122	Mounting support plate (1)	opt.
10	Std.	Cotter pin 1/8" x 1" lg	opt.
11	140-13071	Hoses mounting plate (1)	opt.
12	300-32250	Bolt 1/4" NC x 1" lg + nylon locknut (1)	opt.
13	300-38340	Bolt 7/16" NC x 2" lg + nylon locknut	2
14	25TR04	Cylinder	opt.
15	Std.	Hairpin cotter 7/8" (4)	opt.
16	6004	Clevis pin 1" x 3 1/8" lg (2)	opt.
17	110-32762	Access panel	1
18	8374	Adjustable clamp fastener (welded)	1
19	RSP-1/16x06 NPT	Kit of two unidirectional restrictors 3/8" NPT	
opt.			
19	RSP-1/16x08 NPT	Kit of two unidirectional restrictors 1/2" NPT	
opt.			

10

OPTIONS

170-02983

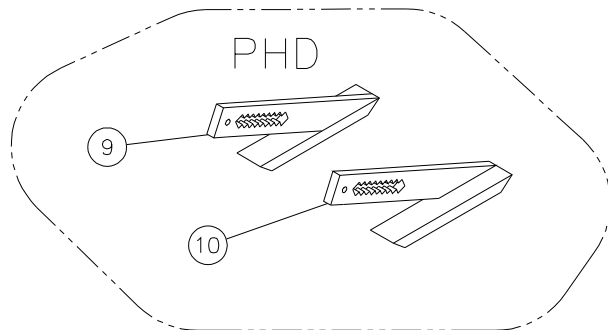
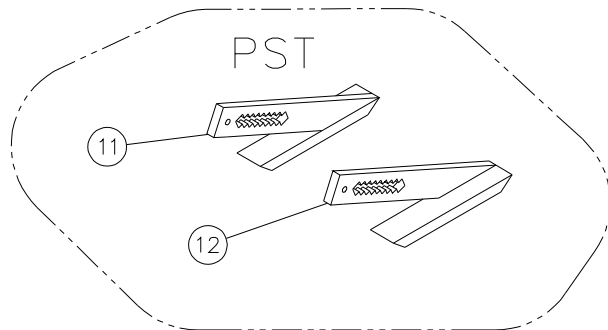
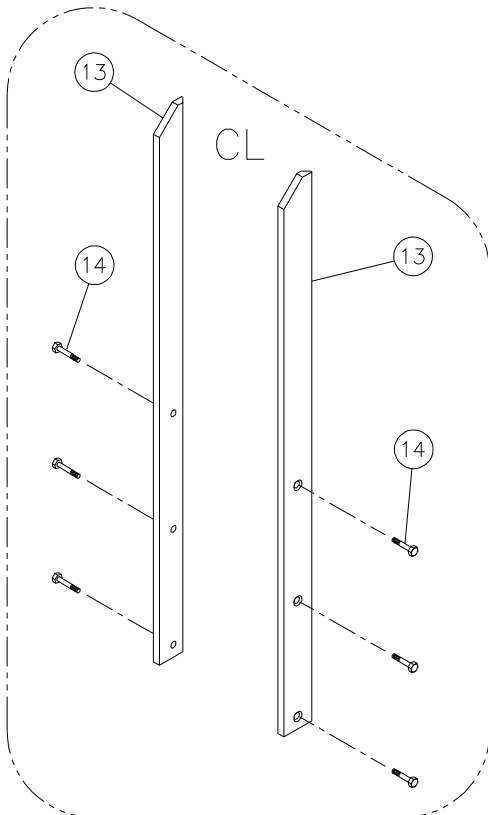
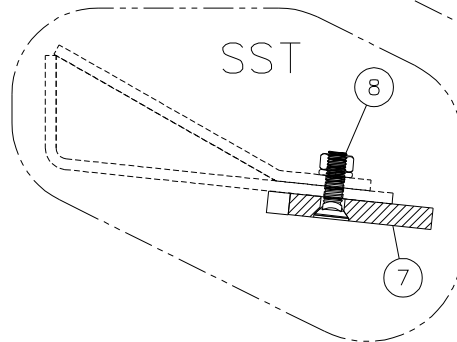
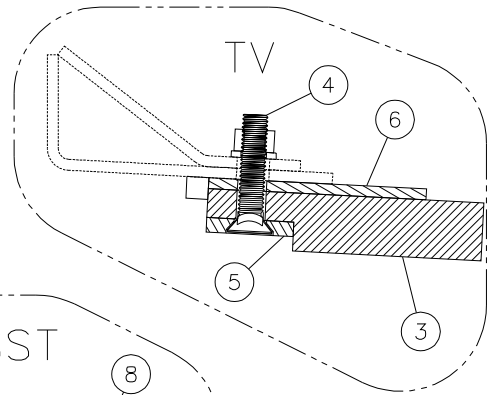
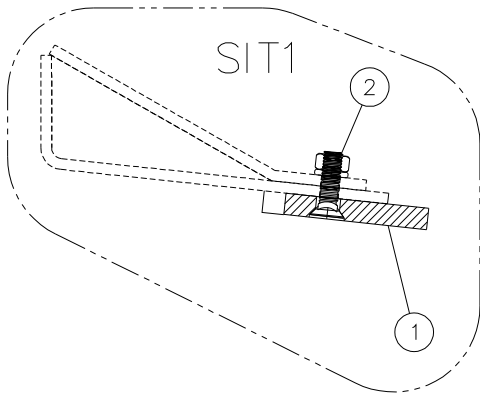

OPTIONS (cont'd)

REF.	PART #	DESCRIPTION	QTY					
			P-540	P-620	P-680(TRC)	P-720(TRC)	P-720(TRC)-74	P-720(TRC)-80
SIT1								
1		Semi-industrial scraper blade, carbon steel, not reversible, not sharpened						
	140-12281	1/2" x 3" x 50 1/4"	1	-	-	-	-	-
	140-12271	1/2" x 3" x 58 1/4"	-	1	-	-	-	-
	140-05801	1/2" x 3" x 64 1/4"	-	-	1	-	-	-
	140-05791	1/2" x 3" x 68 1/4"	-	-	-	1	-	-
	140-11241	1/2" x 3" x 70 1/4"	-	-	-	-	1	-
	140-14151	1/2" x 3" x 76 1/4"	-	-	-	-	-	1
2	319-38310	Plow bolt 7/16" NC x 1 1/2" lg + nut & lock washer	5	6	7	7	7	8
TV								
3	190-05103	Tivar scraper blade, not reversible 1" x 4 3/4" x 50 1/4"	1	-	-	-	-	-
3	190-05113	Tivar scraper blade, not reversible 1" x 4 3/4" x 58 1/4"	-	1	-	-	-	-
3	190-05123	Tivar scraper blade, not reversible 1" x 4 3/4" x 64 1/4"	-	-	1	-	-	-
3	190-02683	Tivar scraper blade, not reversible 1" x 4 3/4" x 68 1/4"	-	-	-	1	-	-
3	190-05133	Tivar scraper blade, not reversible 1" x 4 3/4" x 70 1/4"	-	-	-	-	1	-
3	190-06262	Tivar scraper blade, not reversible 1" x 4 3/4" x 76 1/4"	-	-	-	-	-	1
4	319-38340	Plow bolt 7/16" x 2" lg + nut & lock washer	5	6	7	7	7	8
5	140-13332	Tivar blade lower holder 1/4" x 1 1/2" x 50 1/4"	1	-	-	-	-	-
5	140-13342	Tivar blade lower holder 1/4" x 1 1/2" x 58 1/4"	-	1	-	-	-	-
5	140-13352	Tivar blade lower holder 1/4" x 1 1/2" x 64 1/4"	-	-	1	-	-	-
5	140-13362	Tivar blade lower holder 1/4" x 1 1/2" x 68 1/4"	-	-	-	1	-	-
5	140-13372	Tivar blade lower holder 1/4" x 1 1/2" x 70 1/4"	-	-	-	-	1	-
5	140-14162	Tivar blade lower holder 1/4" x 1 1/2" x 76 1/4"	-	-	-	-	-	1
6	130-59131	Tivar blade upper holder 3/16" x 3 3/4" x 50 1/4"	1	-	-	-	-	-
6	130-59141	Tivar blade upper holder 3/16" x 3 3/4" x 58 1/4"	-	1	-	-	-	-
6	130-59151	Tivar blade upper holder 3/16" x 3 3/4" x 64 1/4"	-	-	1	-	-	-
6	130-59161	Tivar blade upper holder 3/16" x 3 3/4" x 68 1/4"	-	-	-	1	-	-
6	130-59111	Tivar blade upper holder 3/16" x 3 3/4" x 70 1/4"	-	-	-	-	1	-
6	130-59121	Tivar blade upper holder 3/16" x 3 3/4" x 76 1/4"	-	-	-	-	-	1
SST								
7	140-15321	Stainless steel scraper blade, not reversible, not sharpened 1/2" x 3" x 50 1/4"	1	-	-	-	-	-
7	140-15331	Stainless steel scraper blade, not reversible, not sharpened 1/2" x 3" x 58 1/4"	-	1	-	-	-	-
7	140-15341	Stainless steel scraper blade, not reversible, not sharpened 1/2" x 3" x 64 1/4"	-	-	1	-	-	-
7	140-15351	Stainless steel scraper blade, not reversible, not sharpened 1/2" x 3" x 68 1/4"	-	-	-	1	-	-
7	140-15361	Stainless steel scraper blade, not reversible, not sharpened 1/2" x 3" x 70 1/4"	-	-	-	-	1	-
7	140-15371	Stainless steel scraper blade, not reversible, not sharpened 1/2" x 3" x 76 1/4"	-	-	-	-	-	1
8	319-38310	Plow bolt 7/16" NC x 1 1/2" lg + nut & lock washer	5	6	7	7	7	8
8	333-40310	Bolt cyl. head 6 PC 1/2" NC x 1 1/2" lg (inox) + nut & lock washer	opt.	opt.	opt.	opt.	opt.	opt.
PHD								
9	110-07701	Carbon steel skid shoe (left side)	1	1	1	1	1	1
10	110-07711	Carbon steel skid shoe (right side)	1	1	1	1	1	1
PST								
11	110-25341	Stainless steel skid shoe (left side)	1	1	1	1	1	1
12	110-25342	Stainless steel skid shoe (right side)	1	1	1	1	1	1
CL								
13	140-05941	Lateral blade	2	2	2	2	2	2
14	319-38310	Plow bolt 7/16" NC x 1 1/2" lg + nut & lock washer	6	6	6	6	6	6

P.T.O. SHAFT # 6408-E (T20)

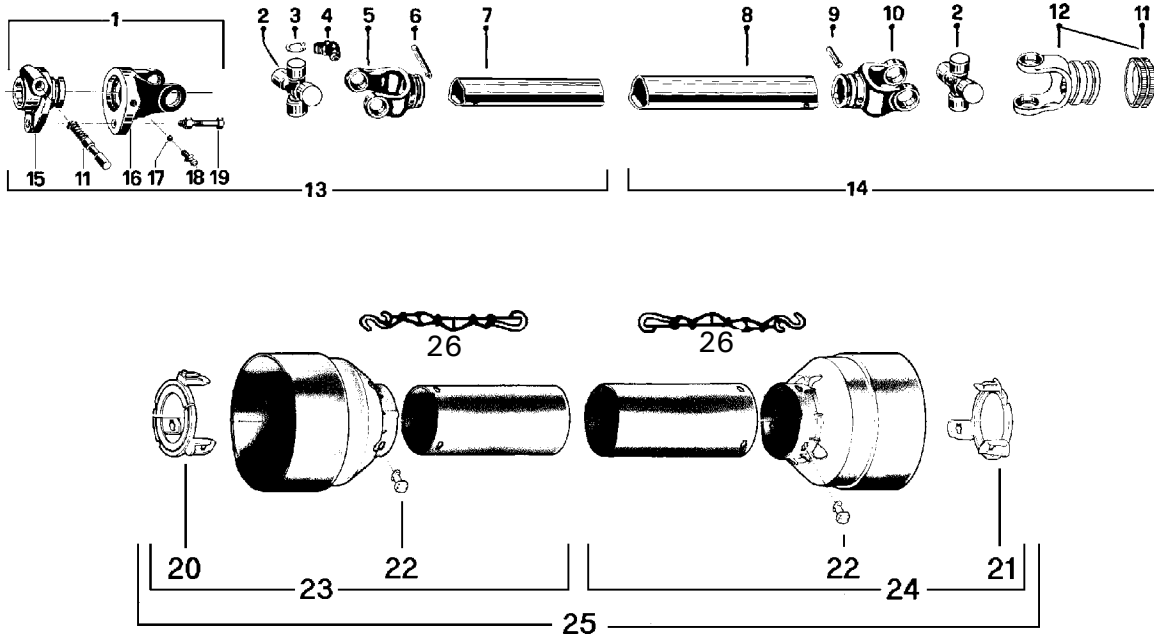

REF.	PART #	DESCRIPTION	QTY
1	6201	Quick disconnect shear yoke assembly	1
2	6208	U-joint + 4 retaining rings + 1 grease fitting	2
3	6203	Retaining ring	8
4	8110	Grease fitting	2
5	6434	Yoke for inner tube	1
6	6433	Stopper for inner tube	1
7	6432	Inner tube	1
8	6431	Outer tube	1
9	6344	Stopper for outer tube	1
10	6430	Yoke for outer tube	1
11	8363	Collar kit	2
12	6409	Yoke with hole 1 3/8"-6 splines + yoke stopper	1
13	6224	P.T.O. section, side with safety shear bolt, inner part, with protector	1
14	6225	P.T.O. section, side without safety shear bolt, outer part, with protector	1
15	6202	Adaptor	1
16	6204	Yoke and shearplate	1
17	6205	Ball	17
18	6206	Grease fitting	1
19	6207	Safety shear bolt M6 x 40mm	1
20	6219-E	Bearing ring for inner guard tube	1
21	6218-E	Bearing ring for outer guard tube	1
22	8109	Stopper	6
23	6221	Inner shield	1
24	6220	Outer shield	1
25	6222	Complete shield	1
26	8308	Safety chain	2

P.T.O. SHAFT # 6248-EG (T40)

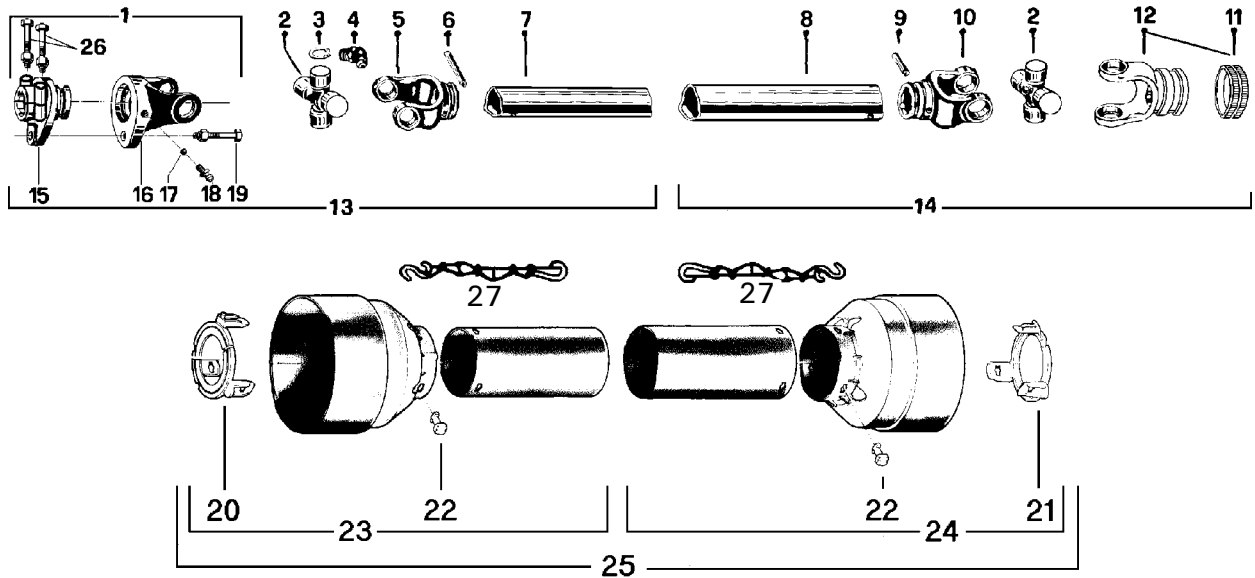

REF.	PART #	DESCRIPTION	QTY
1	6232-2	Safety shear yoke (2 bolts)	1
2	6239	U-joint + 4 retaining rings + 1 grease fitting	2
3	6234	Retaining ring	8
4	8110	Grease fitting	2
5	6353	Yoke for inner tube	1
6	6344	Stopper for inner tube	1
7	6343	Inner tube	1
8	6342	Outer tube	1
9	6341	Stopper for outer tube	1
10	6340	Yoke for outer tube	1
11	8363	Collar kit	1
12	6354	Yoke with hole 1 3/8"-6 splines + yoke stopper	1
13	6236	P.T.O. section, side with safety shear bolt, inner part, with protector	1
14	6237	P.T.O. section, side without safety shear bolt, outer part, with protector	1
15	6233-2	Adaptor (2 bolts)	1
16	6235	Yoke and shearplate	1
17	8070	Ball	17
18	8071	Grease fitting	1
19	6238	Safety shear bolt M8 x 50mm	1
20	6349-E	Bearing ring for inner guard tube	1
21	6348-E	Bearing ring for outer guard tube	1
22	8109	Stopper	6
23	6351	Inner shield	1
24	6350	Outer shield	1
25	6352	Complete shield	1
26	8222	Bolt M12 x 70mm	2
27	8308	Safety chain	2

P.T.O. SHAFT # 8114-EG (T50)

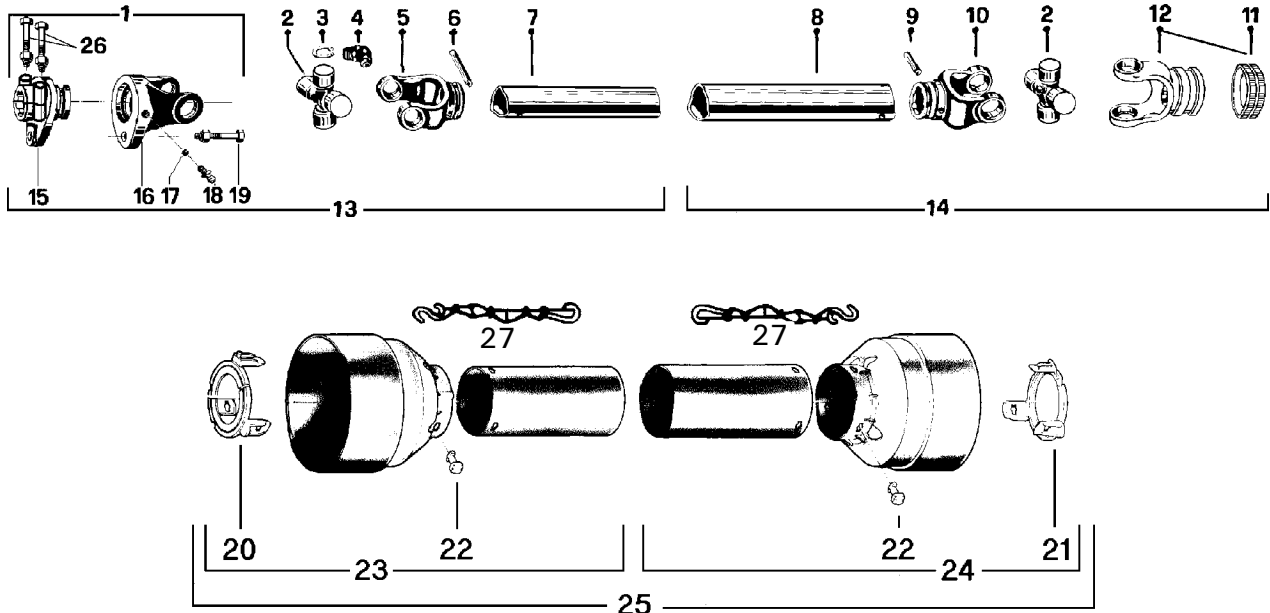

REF.	PART #	DESCRIPTION	QTY
1	8221	Safety shear yoke (2 bolts)	1
2	8073	U joint + 4 retaining rings + 1 grease fitting	2
3	8061	Retaining ring	8
4	8110	Grease fitting	2
5	8079	Yoke for inner tube	1
6	6341	Stopper for inner tube	1
7	8077	Inner tube	1
8	8076	Outer tube	1
9	8142	Stopper for outer tube	1
10	8074	Yoke for outer tube	1
11	8363	Collar kit	1
12	8113	Yoke with hole 1 3/8"-6 splines + yoke stopper	1
13	8235	P.T.O. section, side with safety shear bolt, inner part, with protector	1
14	8236	P.T.O. section, side without safety shear bolt, outer part, with protector	1
15	8223	Adaptor (2 bolts)	1
16	8069	Yoke and shearplate	1
17	8070	Ball	17
18	8071	Grease fitting	1
19	8072	Safety shear bolt M10 x 50mm	1
20	8084-E	Bearing ring for inner guard tube	1
21	8083-E	Bearing ring for outer guard tube	1
22	8109	Stopper	6
23	8086	Inner shield	1
24	8085	Outer shield	1
25	8087	Complete shield	1
26	8222	Bolt M12 x 70mm	2
27	8308	Safety chain	2

10

GEAR BOX # 6451 (T281)

170-05571

Oil volume required: 0.5 liter.
Use SAE 80W90 oil or equivalent.

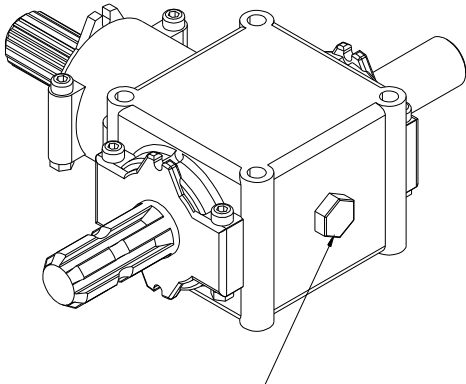

Oil filler plug, drain plug and oil level plug

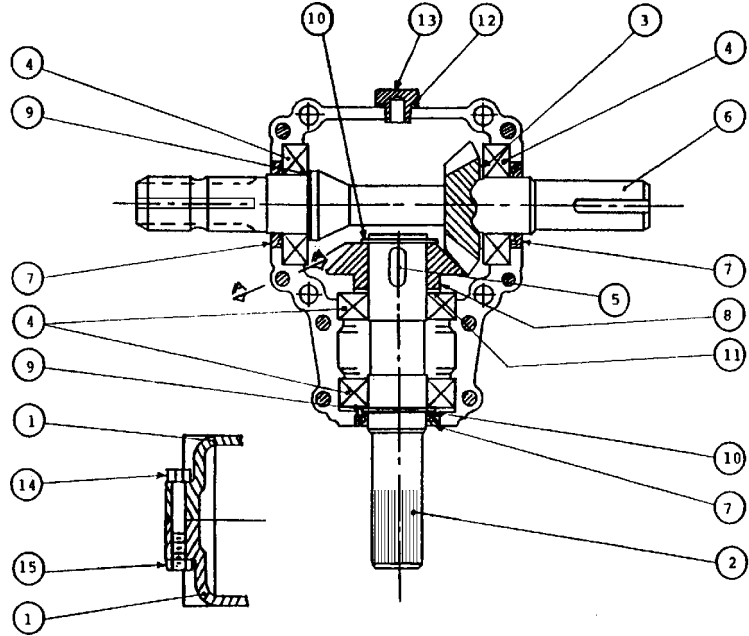

REF.	PART #	DESCRIPTION	QTY
1	6414	Casing	2
2	6429	Side shaft (1 1/4" - 19 splines)	1
3	6416	Spacer 35,3 x 48	1
4	6207-2RS	Ball bearing	4
5	6418	Key 10 x 8 x 30	1
6	6419	Impeller shaft (1 1/4" & 1 3/8" - 6 splines)	1
7	6420	Seal 35 x 52 x 7	3
8	6421	Gear Z19	1
9	6422	Spacer 35.3 x 0.5	2
10	6423	Snap ring 35 UNI7435	2
11	6424	Spacer 35.3 x 0.6	1
12	6425	Oil seal	1
13	6426	Oil plug (oil filler plug, drain plug and oil level plug)	1
14	6427	Bolt M8 x 55	8
15	6428	Nut M8	8

GEAR BOX # 8251 (T27D)

170-05581

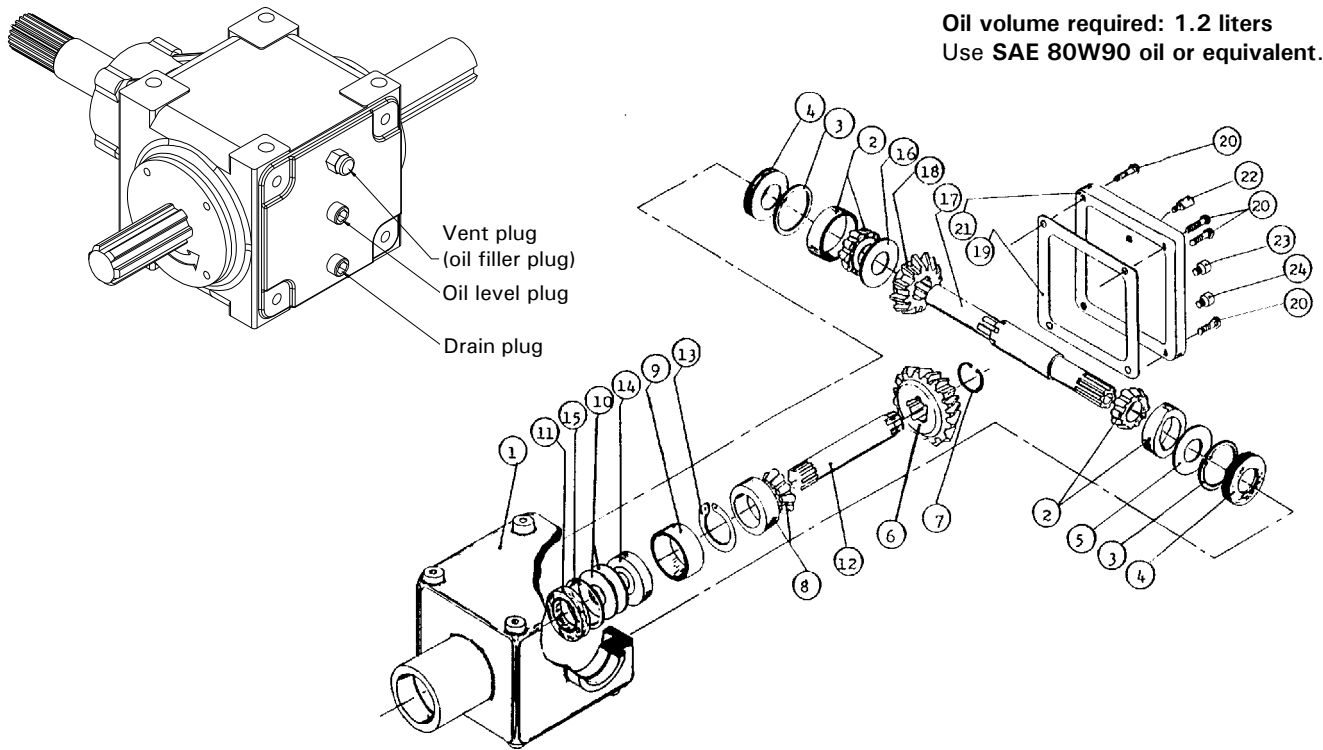

REF.	PART #	DESCRIPTION	QTY
1	8043	Casing	1
2	30208-A	Roller bearing	2
3	8045	Inside circlip 80mm	2
4	8046	Oil seal 40 x 80 x 12mm	2
5	8047	Adjusting washer	1
6	8048	Gear Z18	1
7	8049	Outside circlip 40mm	1
8	30207-A	Roller bearing	1
9	8051	Spacer ring	1
10	8052	Adjusting washer	2
11	8053	Oil seal 35 x 72 x 12mm	1
12	8054	Side shaft (1 1/4" - 19 splines)	1
13	8055	Inside circlip 72mm	1
14	6207-2RS	Ball bearing	1
15	8057	Outside circlip 35mm	1
16	8058	Adjusting washer	1
17	8252	Impeller shaft (1.575" & 1 3/8" - 6 splines)	1
18	8060	Gear Z-18	1
19	- - -	Use silicone caulking	-
20	8062	Bolt M10 x 14mm	4
21	8063	Cover	1
22	8065	Vent plug (oil filler plug)	1
23	8064	Plug (oil level)	1
24	8064	Plug (oil drain)	1

CYLINDER 25TR04

170-02141

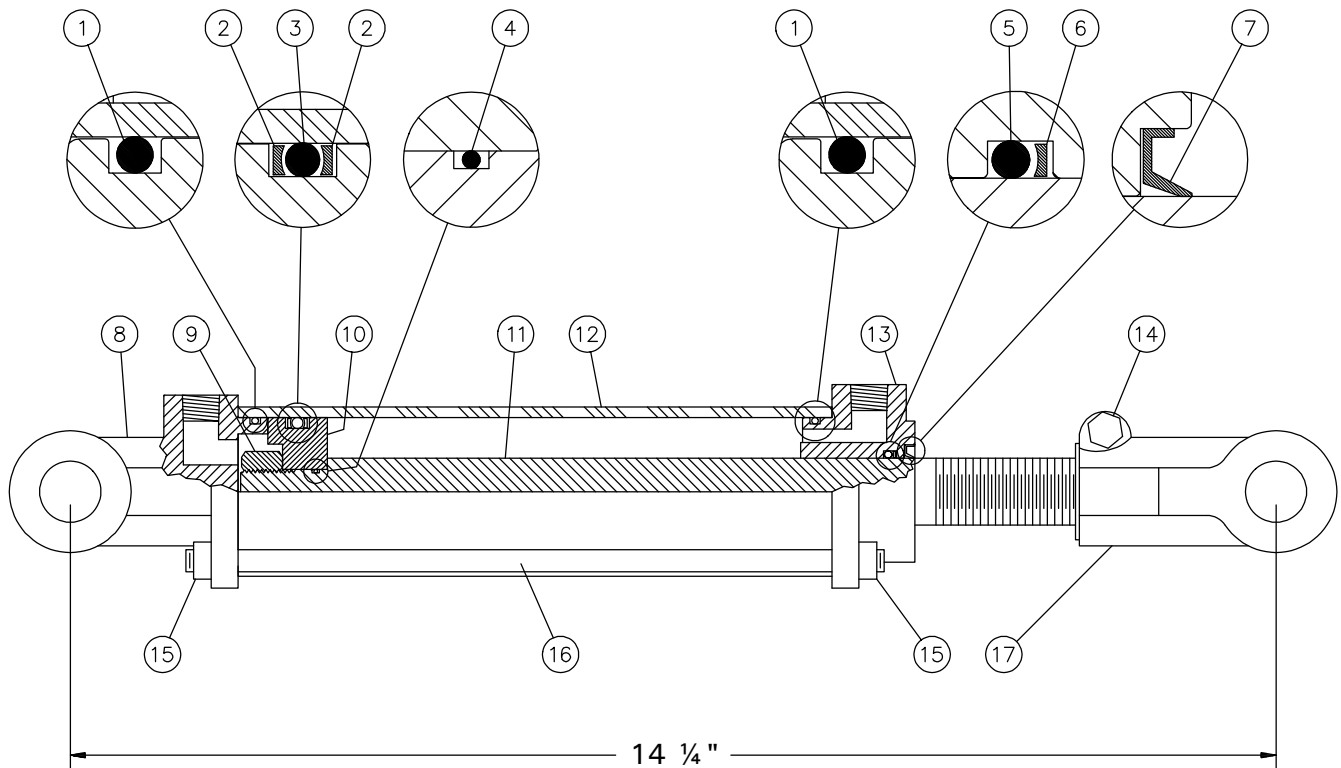

REF.	PART #	DESCRIPTION	QTY
1	See #RK25TR	O-ring 1/8" x 2 1/4" x 2 1/2"	2
2	See #RK25TR	Back-up 2 1/2" o.d. x 3/16 ø	2
3	See #RK25TR	O-ring 3/16" x 2 1/8" x 2 1/2"	1
4	See #RK25TR	O-ring 1/16" x 5/8" x 3/4"	1
5	See #RK25TR	O-ring 1/8" x 1 1/8" x 1 3/8"	1
6	See #RK25TR	Back-up 1 3/8" o.d. x 1/8" ø	1
7	See #RK25TR	Wiper 1 1/8" i.d. x 1 5/8" o.d.	1
8	492401	Yoke (for 2 1/2" tube)	1
9	338-46000	Nut 3/4" NF	1
10	4924-31	Piston 2 1/2" ø	1
11	491980-04	Piston rod 1 1/8"	1
12	491668-04	Cylinder body 2 1/2" ø	1
13	492421	Head (for 2 1/2" tube)	1
14	300-36355	Bolt 3/8" NC x 2 1/4" + nut	1
15	336-36000	Nut 3/8" NC	8
16	Std.	Threaded rod 3/8" NC x 8" lg	4
17	458599	Yoke (for 1 1/8" rod)	1
NI*	8183	Pin 1" ø + cotter pin	2
NI*	RK25TR	Repair kit for cylinder 2 1/2" (includes # 1, 2, 3, 4, 5, 6, & 7)	1

*NI = NOT ILLUSTRATED

HYDRAULIC MOTOR MLH100, MLH125 & MLH250

CUSHION VALVE H110

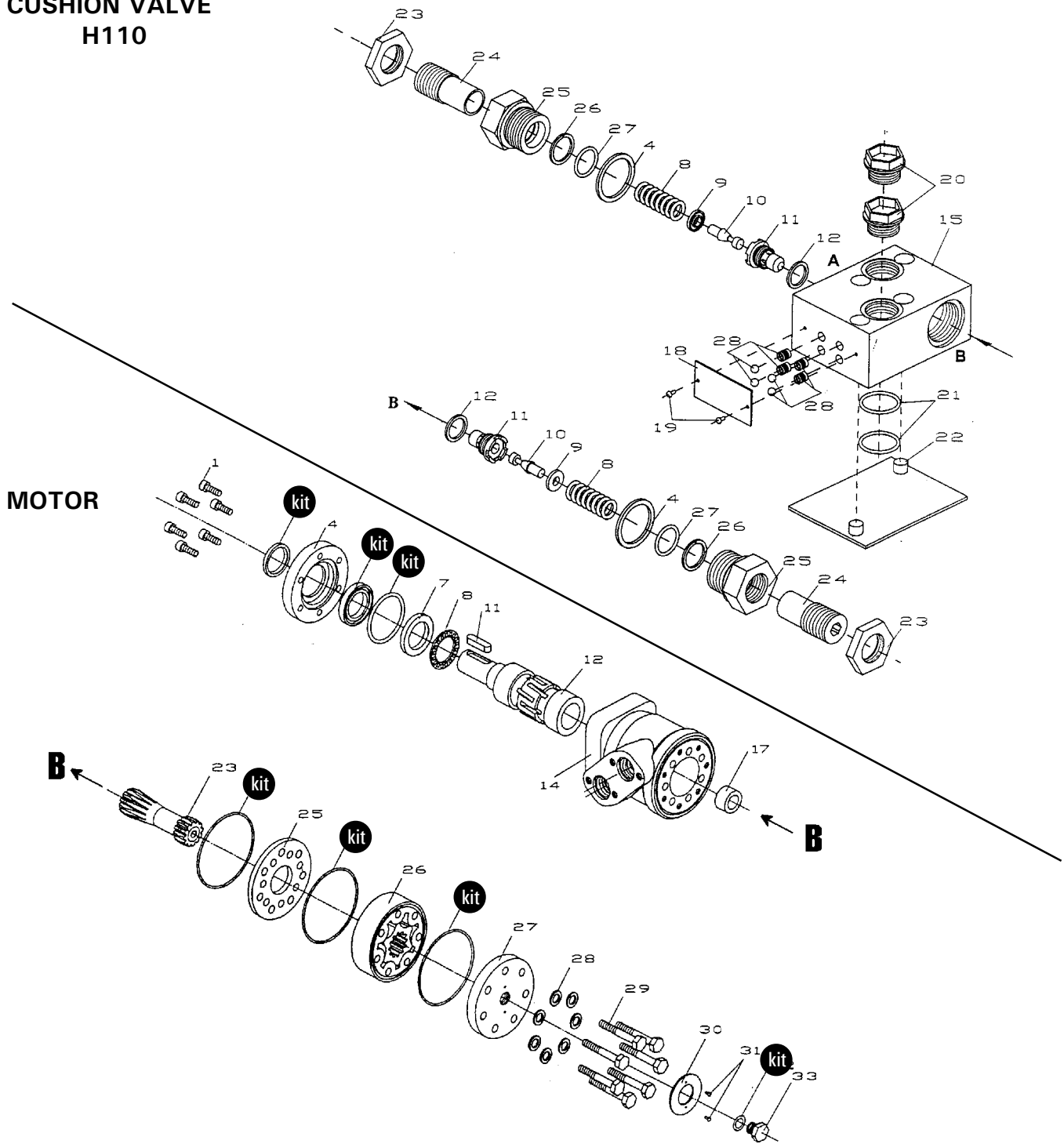







10





REF.	PART #	DESCRIPTION	QTY
kit	8368	Set of seals.....	1
11	8369	Key for "Orbit" motor.....	1

TORQUE CHART

TORQUE SPECIFICATION TABLE

Thread UNC and UNF		Grade 2 				Grade 5   				Grade 8*   			
Bolt size		Torque				Torque				Torque			
Inches	mm	Pound feet min.	max.	Newton meters min.	max.	Pound feet min.	max.	Newton meters min.	max.	Pound feet min.	max.	Newton meters min.	max.
1/4	6.35	5	6	6.8	8.13	9	11	12.2	14.9	12	15	16.3	30.3
5/16	7.94	10	12	13.6	16.3	17	20.5	23.1	27.8	24	29	32.5	39.3
3/8	9.53	20	23	27.1	31.2	35	42	47.5	57.0	45	54	61.0	73.2
7/16	11.11	30	35	40.7	47.4	54	64	73.2	86.8	70	84	94.9	113.9
1/2	12.70	45	52	61.0	70.5	80	96	108.5	130.2	110	132	149.2	179.0
9/16	14.29	65	75	88.1	101.6	110	132	149.2	179.0	160	192	217.0	260.4
5/8	15.88	95	105	128.7	142.3	150	180	203.4	244.1	220	264	298.3	358.0
3/4	19.05	150	185	203.3	250.7	270	324	366.1	439.3	380	456	515.3	618.3
7/8	22.23	160	200	216.8	271.0	400	480	542.4	650.9	600	720	813.6	976.3
1	25.40	250	300	338.8	406.5	580	696	786.5	943.8	900	1080	1220.4	1464.5
1 1/8	25.58	-	-	-	-	800	880	1084.8	1193.3	1280	1440	1735.7	1952.6
1 1/4	31.75	-	-	-	-	1120	1240	1518.7	1681.4	1820	2000	2467.9	2712.0
1 3/8	34.93	-	-	-	-	1460	1680	1979.8	2278.1	2380	2720	3227.3	3688.3
1 1/2	38.10	-	-	-	-	1940	2200	2630.6	2983.2	3160	3560	4285.0	4827.4

* Thick nuts must be used with grade 8 bolts.

Size of screw	Thread	Pitch (mm)	Grade 4T  				Grade 7T 				Grade 8T  			
			Torque				Torque				Torque			
			Pound feet min.	max.	Newton meters min.	max.	Pound feet min.	max.	Newton meters min.	max.	Pound feet min.	max.	Newton meters min.	max.
M6	UNC	1.00	3.6	5.8	4.9	7.9	5.8	9.4	7.9	12.7	7.2	10	9.8	13.6
M8	UNC	1.25	7.2	14	9.8	19	17	22	23	29.8	20	26	27.1	35.2
M10	UNC	1.5	20	25	27.1	33.9	34	40	46.1	54.2	38	46	51.5	62.3
M12	UNC	1.75	28	34	37.9	46.1	51	59	69.1	79.9	57	66	77.2	89.4
M14	UNC	2.0	49	56	66.4	75.9	81	93	109.8	126	96	109	130.1	147.7
M16	UNC	2.0	67	77	90.8	104.3	116	130	157.2	176.2	129	145	174.8	196.5
M18	UNC	2.0	88	100	119.2	136	150	168	203.3	227.6	175	194	237.1	262.9
M20	UNC	2.5	108	130	146.3	176.2	186	205	252	277.8	213	249	288.6	337.4
M8	UNF	1.0	12	17	16.3	23	19	27	25.7	36.6	22	31	29.8	42
M10	UNF	1.25	20	29	27.1	39.3	35	47	47.4	63.7	40	52	54.2	70.5
M12	UNF	1.25	31	41	42	55.6	56	68	75.9	92.1	62	75	84	101.6
M14	UNF	1.5	52	64	70.5	86.7	90	106	122	143.6	107	124	145	168
M16	UNF	1.5	69	83	93.5	112.5	120	138	162.6	187	140	158	189.7	214.1
M18	UNF	1.5	100	117	136	158.5	177	199	239.8	269.6	202	231	273.7	313
M20	UNF	1.5	132	150	178.9	203.3	206	242	279.1	327.9	246	289	333.3	391.6

Use the above torques when special torque is not given.

NOTE: These values apply to fasteners as received from supplier, dry, or when lubricated with normal engine oil. They do not apply if extreme pressure lubricants are used.

WARRANTY

12

PRONOVOST warrants this product to the initial purchaser for the period of one year from the date of purchase against defects in materials and workmanship.

We will replace or repair defective parts free of charge if they are returned to our plant in St-Tite, Quebec, Canada.

Transportation charges are the responsibility of the customer. This warranty is not transferable.

Hydraulic cylinders and motors are covered by the manufacturer of these items.

The PTO shafts are warranted by the manufacturer and cover **only** defects in material and workmanship, and is conditional to recommended use and installation only.

All PRONOVOST spare parts purchased are covered by a three (3) month warranty.

This warranty becomes void and nul if the equipment is modified, breaks down as the result of an accident, is not operated according to manufacturer's recommendations, damaged by negligence or if maintenance has not been carried out as specified.

Our obligation is limited to the replacement or repair of the defective part. PRONOVOST accepts no responsibility for direct or indirect consequential damages of any kind.

Ce manuel est aussi disponible en français.
Veuillez téléphoner.



LES MACHINERIES PRONOVOST INC.
260, Haut du Lac Sud (route 159),
Saint-Tite, Quebec, Canada, G0X 3H0
Tel.: (418) 365-7551, Fax: (418) 365-7954
www.pronovost.qc.ca