

# PRONOVOST

## OPERATOR'S / PARTS MANUAL

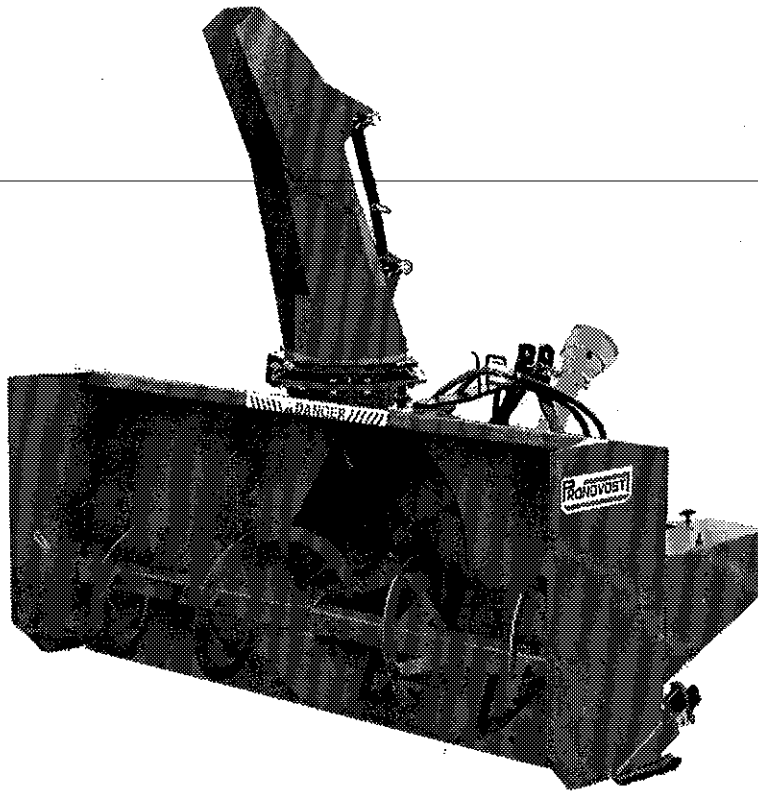

### *Snowblowers* Models

**P-540 & P-540TRC**

**P-620 & P-620TRC**

**P-680 & P-680TRC**

**P-720 & P-720TRC**

Copyright © Les Machineries Pronovost Inc., 1997

All rights reserved.  
Printed in Canada.

# TABLE OF CONTENTS

Section	Item	Page
1	<b>Introduction</b> .....	5
2	<b>Safety</b> .....	6
	General Safety .....	6
	Safety in Operation .....	6
	Safety with Maintenance .....	7
	Safety in Transport .....	7
	Safety in Storage .....	7
3	<b>Decals</b> .....	8
	Safety Decals .....	8
	Maintenance Decals .....	10
4	<b>Assembly</b> .....	11
	General assembly .....	11
5	<b>Start-up</b> .....	12
	Basic Start-up Procedures .....	12
6	<b>Maintenance</b> .....	13
7	<b>Storage</b> .....	14
8	<b>Trouble Shooting</b> .....	15
9	<b>Specifications</b> .....	17
10	<b>Parts List</b> .....	18
	Snowblowers P-540, P-620, P-680, P-720 .....	18
	Snowblowers P-540TRC, P-620TRC, P-680TRC, P-720TRC .....	21
	Manual Chute Kit M-4864 .....	25
	Hydraulic Chute Kit: Motor SP-4864 .....	26
	Semi-industrial Chute PSI-4864 .....	27
	P.T.O. Shaft 6408 .....	28
	P.T.O. Shaft 6248 .....	29
	P.T.O. Shaft 8114 .....	30
	Gear box 6451 .....	31
	Gear Box 8251 .....	32
	Cylinder 25TR04 .....	33
	Hydraulic Motor DH 100, DH 125 & DH 250 .....	34
11	<b>Torque Chart</b> .....	35
12	<b>Warranty</b> .....	36

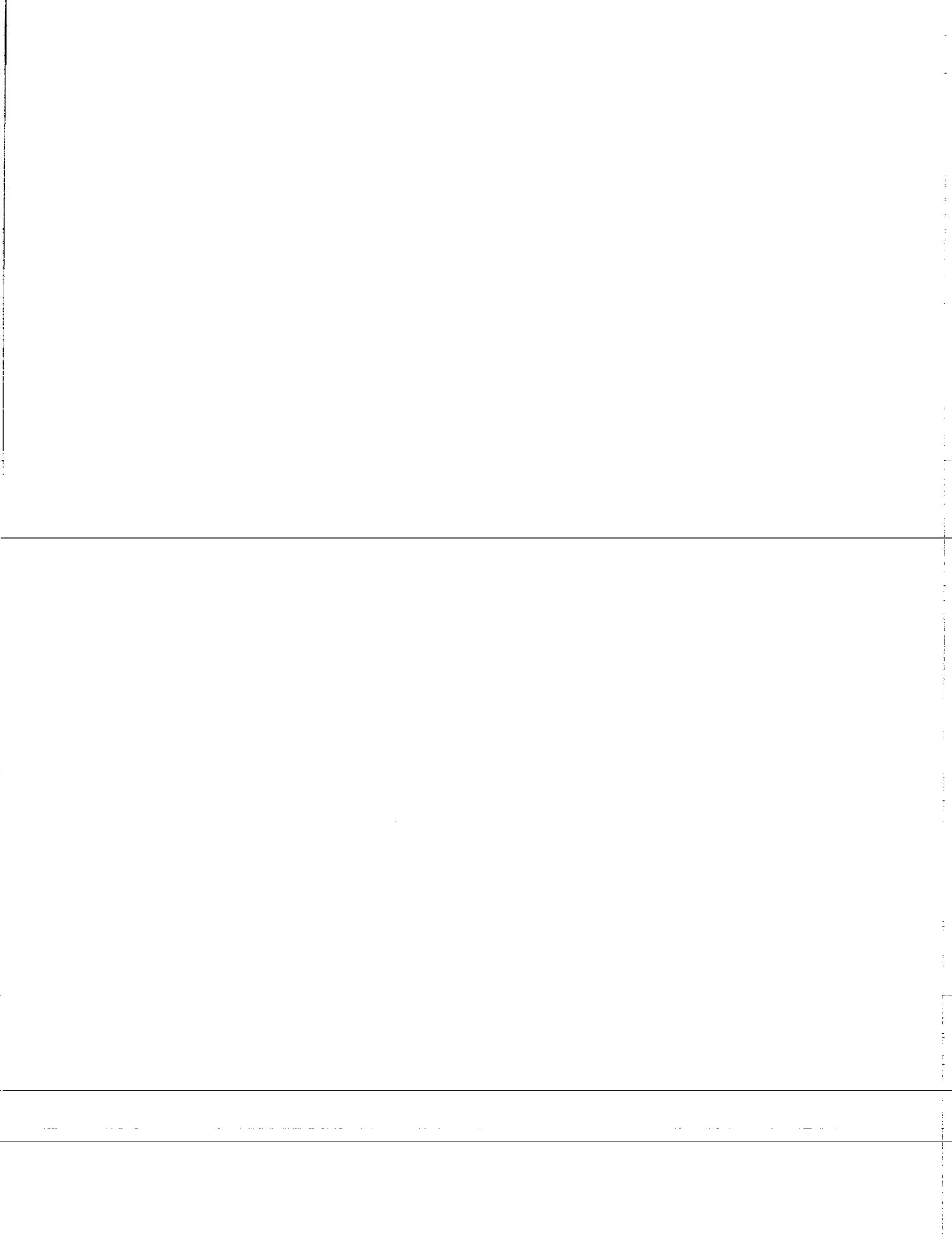

---

---

# INTRODUCTION

---

1

## CONGRATULATIONS!

Thank you for choosing PRONOVOST. We are confident this equipment will meet your requirements in terms of quality, performance and reliability.

This manual was prepared to assist you in the safe operation of your new Snowblower. It contains important information which will help you achieve excellent returns with your Snowblower for years to come.

Please read this manual completely before operating your Snowblower and keep it for future reference.

Before starting the machine, you or any other person who will be operating the Snowblower must familiarize yourself with the safety recommendations and the operating instructions. Please read carefully and be sure to understand and follow all recommendations and procedures.

In this manual, the right and left sides are identified as shown on Figure 1.

If you require additional information on your Snowblower, please contact your PRONOVOST Dealer.

**NOW** take a moment to enter the model, serial number and the date of purchase of your Snowblower in the space provided.

When ordering parts from your Dealer, please refer to these numbers for a fast and efficient service. Use PRONOVOST parts for replacement.

The model and serial numbers are on the name plate shown on Fig. 1.

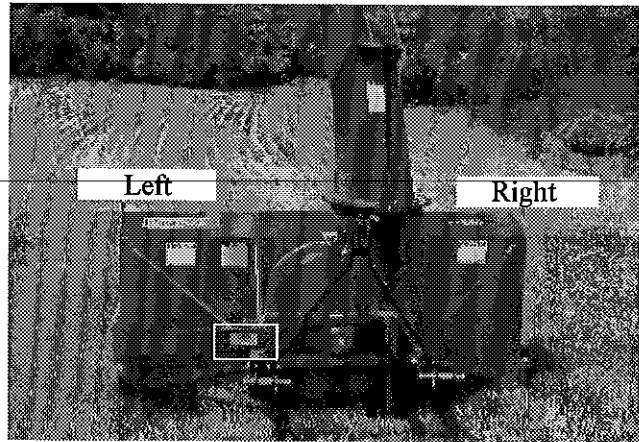

Figure 1

MODEL: \_\_\_\_\_ 

SERIAL NO: \_\_\_\_\_ 

DATE OF PURCHASE: \_\_\_\_\_ 

---

---

# SAFETY

---

## GENERAL SAFETY

2

### WHEN YOU SEE THIS SYMBOL



**ATTENTION!**

**BE ALERT  
YOUR SAFETY IS INVOLVED**

This symbol «SAFETY ALERT» is used in this manual and on the safety decals on the Snowblower. It warns you of the possibility of danger. Carefully read, understand and follow all safety recommendations before operating the Snowblower.

- 1) Careful operation is the best assurance against accidents. Carefully read this manual and follow all recommendations before operating your Snowblower. It is the owner's responsibility to make sure that anyone who will operate the Snowblower will read this manual before operating the equipment.
- 2) Familiarize yourself with all controls and always be ready to stop the Snowblower quickly in case of emergency.
- 3) Never let a child operate the Snowblower.
- 4) Do not modify the Snowblower. Any non authorized modification may affect the efficiency and/or safety of the equipment and will automatically void the warranty.
- 5) Never operate the Snowblower with defective parts or if damaged in any way. Have it repaired before operating.
- 6) Make sure all fasteners are in place and properly secured or tightened. Refer to torque chart on page 35.
- 7) Avoid wearing loose fitting clothing when working with the Snowblower. These could get entangled in moving parts of the equipment and cause accidents.
- 8) Prolonged exposure to noise may hamper hearing. Protect yourself by wearing adequate protection devices.
- 9) Hydraulic fluids under pressure can damage your skin. Do not use your hands to locate a leak.
- 10) Before the beginning of the snow season, inspect all areas where the Snowblower will be used and remove any object which may cause an accident and/or damage the equipment.
- 11) Never operate your Snowblower in poor visibility or without proper lighting conditions.

## SAFETY IN OPERATION

- 1) Be sure there are no obstructions around the equipment and that no one stands near the equipment when in operation.
- 2) Do not operate an engine in a confined or non ventilated area.
- 3) Do not perform any adjustments, cleaning, maintenance or repairs with the engine running. The engine must be stopped and the P.T.O. disengaged. Preferably remove the key from the ignition.
- 4) Wear adequate clothing when working in cold or windy conditions.
- 5) Adjust skid shoes for proper ground clearance of scraper blade, especially in rough terrain or soft ground conditions.
- 6) Before operating, make sure the P.T.O. is properly installed and secured.
- 7) Before starting-up the Snowblower, make sure the auger and drum areas are free of ice.
- 8) Put P.T.O. control in neutral position before starting engine.
- 9) Keep hands, feet and clothing away from moving parts of the Snowblower. Stay away from the discharge chute.

---

---

## ***SAFETY (cont'd)***

---

- 10) Before unplugging the chute, always disengage the P.T.O., stop the engine and relieve all hydraulic pressures.
- 11) Do not operate in excessive inclined conditions. Be careful when turning in slopes.
- 12) Never operate your Snowblower with missing guards or without protective devices in place.
- 13) Do not operate your Snowblower near buildings, windows or other vehicles without prior and proper adjustment of the chute deflector.
- 14) Never aim discharge chute towards people or animals. This may cause serious injuries.
- 15) Always reduce operating speed in slippery conditions.
- 16) Be careful when backing-up, make sure you have good visibility.
- 17) Always be on the lookout for objects which may enter the Snowblower.
- 18) If undue vibrations are felt, disengage the P.T.O., stop the motor and look for the cause of the vibration. Vibration is usually the indication of a problem.
- 19) At the end of the operation, disengage the P.T.O., lower the Snowblower, put transmission in neutral, apply parking brake, stop engine and remove the key from the ignition.

### ***SAFETY WITH MAINTENANCE***

- 1) Perform the Snowblower maintenance according to recommendations contained in this manual.

- 2) Stop engine and relieve all hydraulic pressures before doing inspection, maintenance or repairs.
- 3) Never perform any work under the Snowblower while it is supported only by the tractor's hydraulic system. It must be completely supported by wooden blocks or other safe means.

**2**

### ***SAFETY IN TRANSPORT***

- 1) On public roads, use proper safety lights and check local regulations.
- 2) Be alert while driving on the road. Never carry passengers.
- 3) Always disengage P.T.O. while moving from one area of work to another.
- 4) It is recommended to use both brake pedals simultaneously for better control.
- 5) The recommended road speed should be such as to maintain full control over steering and braking.
- 6) Be careful while backing up, make sure you have good visibility.

### ***SAFETY IN STORAGE***

- 1) Provide adequate supports to prevent any accidental overturning of the Snowblower.
- 2) Do not let children play in the area where the Snowblower is stored.

# DECALS

## SAFETY DECALS

The safety decals are affixed wherever special safety precautions are indicated. Locate them on the machine and read them carefully. If a decal is damaged, lost or illegible, install a new one. The following photos indicate where each one must be installed.

3



Figure 3

**! ATTENTION**

- 1- FOR SAFE OPERATION, FOLLOW OPERATING INSTRUCTIONS IN OPERATOR'S MANUAL.
- 2- KEEP HANDS, FEET AND CLOTHINGS AWAY FROM POWER DRIVEN PARTS.
- 3- STOP ENGINE BEFORE LEAVING THE EQUIPMENT.
- 4- MACHINE HAS TO BE COMPLETELY STOPPED BEFORE STARTING TO ADJUST OR LUBRICATE.
- 5- KEEP PEOPLE AND PETS AT SAFE DISTANCE FROM MACHINE.
- 6- KEEP ALL GUARDS AND SHIELDS IN PLACE.

---

- 1- POUR UN FONCTIONNEMENT SÉCURITAIRE SUIVRE LES INSTRUCTIONS DANS LE MANUEL D'OPÉRATION.
- 2- GARDER LES MAINS, PIEDS ET VÊTEMENTS ÉLOIGNÉS DES ÉLÉMENTS MOBILES OU ROTATIFS.
- 3- AVANT DE QUITTER LA MACHINE ARRÊTER LE MOTEUR.
- 4- ARRÊTER COMPLÈTEMENT LA MACHINE POUR EFFECTUER L'ENTRETIEN ET L'AJUSTEMENT.
- 5- GARDER LES GENS ET LES ANIMAUX À UNE DISTANCE SÉCURITAIRE.
- 6- GARDER TOUS LES ÉCRANS PROTECTEUR EN PLACE.

PA 93-01

Figure 2  
Decal A

Part no.: A102

**! DANGER**

TO AVOID SERIOUS INJURIES, KEEP CLEAR OF EQUIPMENT WHILE IN OPERATION.

---

POUR ÉVITER DES BLESSURES GRAVES SE TENIR LOIN DE CET ÉQUIPEMENT LORSQU'IL EST EN MARCHÉ.

PD 93-03

Figure 4  
Decal B

Part no.: A101

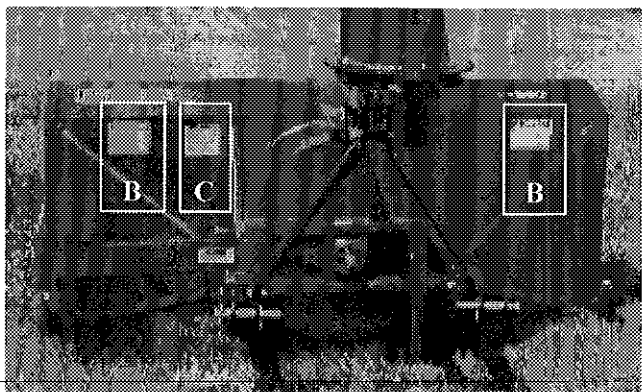

Figure 5



## DECALS (cont'd)

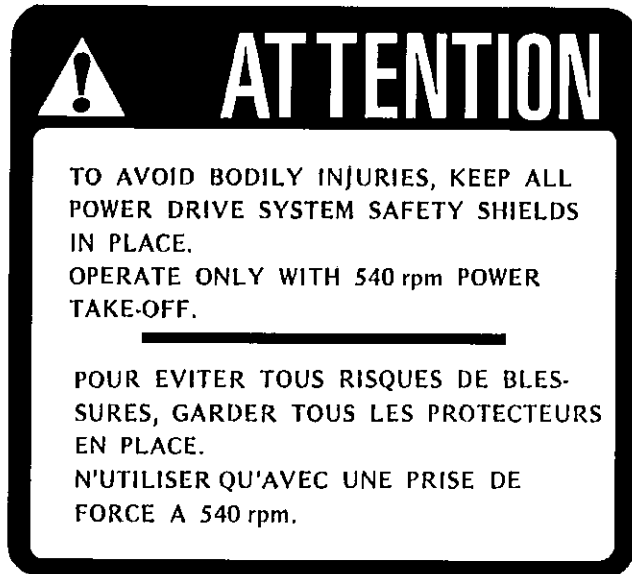

Figure 6  
Decal C

Part no.: A107



Figure 7  
Decal D

Part no.: A103

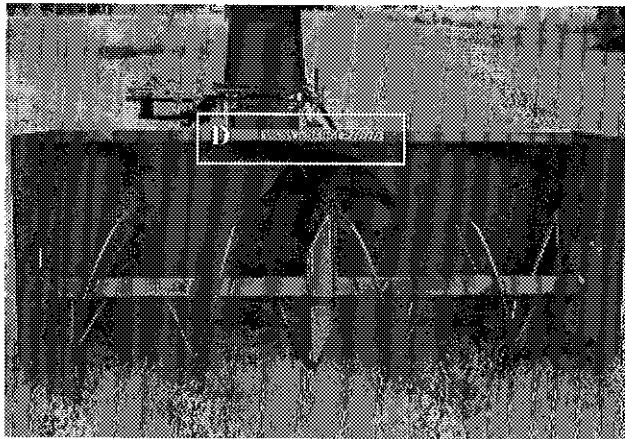

Figure 8

Decal E in Fig. 9 is located directly on the P.T.O. shaft. It is not visible when the safety shield is in place. It must never be visible when you operate the equipment.



**3**

Figure 9  
Decal E

Part no.: A108

# DECALS (cont'd)

3

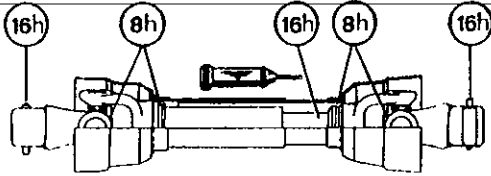

Figure 10  
Decal F

Part no.: A 109

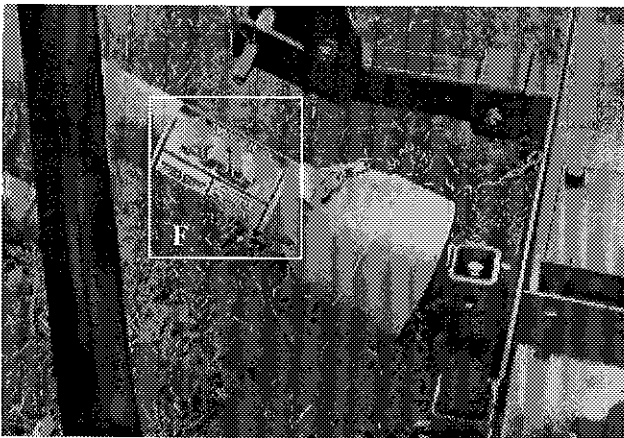

Figure 11

## MAINTENANCE DECALS

The maintenance decals indicate the points requiring lubrication. Refer to maintenance section for more details.

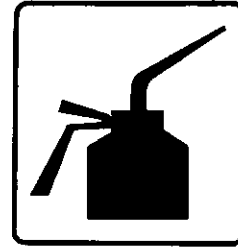

Figure 12

Part no.: A 105



Figure 13

Part no.: A 106



Figure 14  
Decal G

Part no.: A104

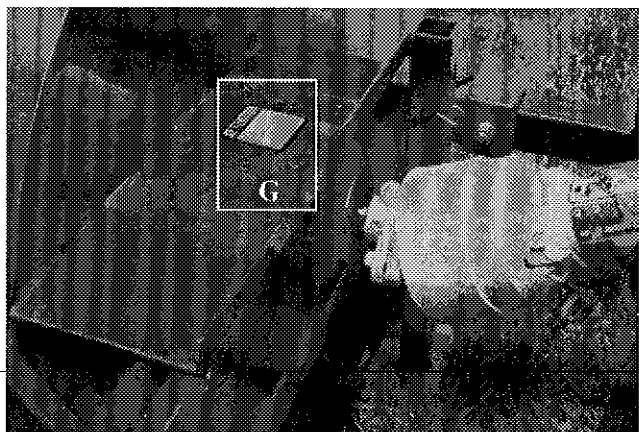

Figure 15

---

---

# ASSEMBLY

---

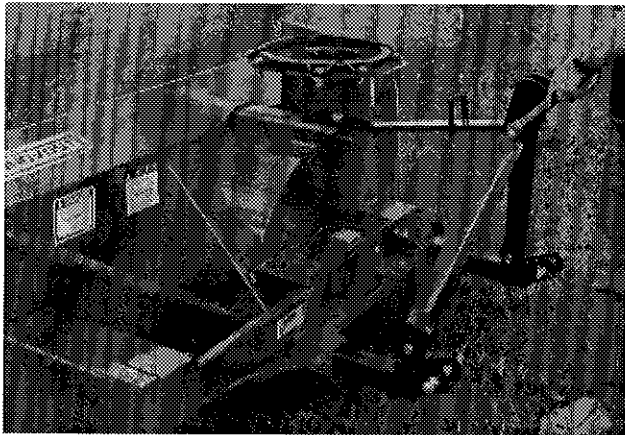

Figure 16



Figure 17

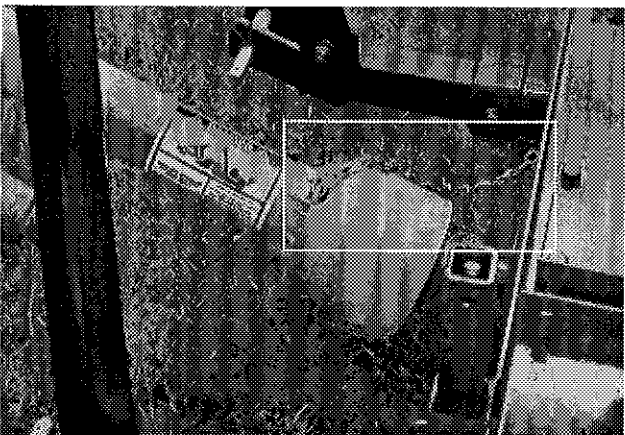

Figure 18

## ASSEMBLY

- 1) The Snowblower is shipped partly assembled.
- 2) Install 3-point system according to the model of your Snowblower. (See section 10 for parts numbers). Use the holes most convenient to the type of tractor used (Fig. 16).
- 3) Install P.T.O. shaft with the shear pin end onto the Snowblower gear box (Fig. 17). Then attach safety shield support chain as shown (Fig. 18).  
**WARNING:** The telescoping tubes of the drive shaft must never be allowed to bottom out while maintaining a minimum overlap of 6 inches.
- 4) If you install a hydraulic cylinder on the chute deflector, use model 25TR04 cylinder.
- 5) For the installation of the chute rotation mechanism, please refer to page 25 through 27, according to the type used.

4

---

# STARTING-UP

---



Figure 31

5

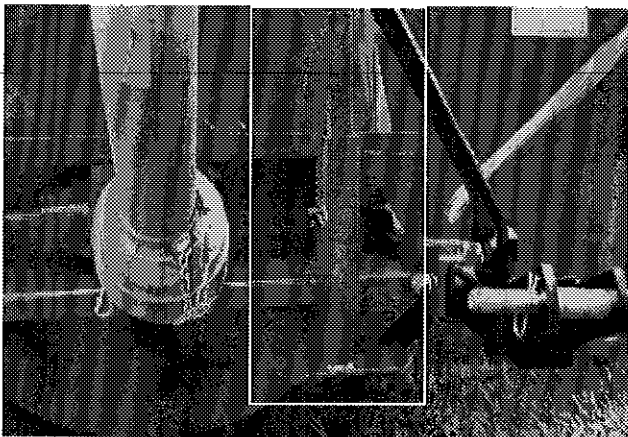

Figure 32



Figure 33

## START-UP PROCEDURES

- 1) Check oil level in gearbox. Use S.A.E. W90 gear box oil.
- 2) Lubricate all points with a good quality multipurpose grease.
- 3) Check chain take-up adjustment. The spring maintaining the tension must be compressed to a length between 3" and 3½".
- 4) Verify for adequate tightness of all fastening devices. Refer to torque chart on page 35.
- 5) Adjust skid shoes according to ground conditions (Fig. 31).
- 6) Following the installation of the Snowblower on the tractor, **do not forget** to lift the storage support (Fig. 32).
- 7) Make sure of a 540 RPM input to your Snowblower.
- 8) Check impeller adjustment. The tip of the blades should be approximately 1/8" to 3/16" from the discharge wall of the drum. If necessary, adjust with the take-up screws provided (Fig. 33).

---

---

# MAINTENANCE

---

- 1) Wipe off all grease fittings with a clean cloth before adding grease in order to avoid injecting dirt and sand.
- 2) Repair or replace damaged grease fittings.
- 3) Lubricate all grease fittings every 10 hours of operation.
- 4) Oil drive chain every 8 hours of operation.
- 5) Lubricate P.T.O. shaft as indicated below:
  - 6) Check oil level in gear box once a month. If necessary add oil.
  - 7) Check tension of drive chain every 25 hours of operation and adjust if necessary.
  - 8) Check for tightness of bearing collars every 50 hours of operation.
  - 9) Change gearbox oil once a year. Use gear box oil S.A.E. W90 rated API, class GL-5.
  - 10) Check all nuts and bolts once a year. If necessary use torque chart on page 35.
  - 11) Always use Grade 5 shear bolts.

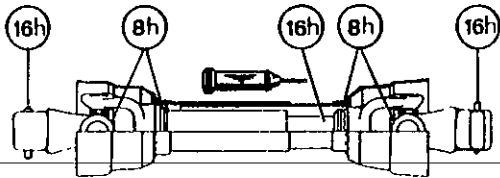

Pull out the P.T.O. and lubricate between the two tubes with low temperature grease.

---

---

## ***STORAGE***

---

- 1) Store the Snowblower in a cool, dry place.
- 2) Support the Snowblower with wooden blocks.
- 3) Keep all piston rods in the retracted position. This will assure better protection against the elements.
- 4) Clean your Snowblower.
- 5) Thoroughly inspect all parts of the Snowblower. Replace or repair worn or defective parts.
- 6) Touch-up or repaint if necessary.
- 7) Lubricate all points before storage.

# TROUBLESHOOTING

## P.T.O. SHAFT

PROBLEM	POSSIBLE CAUSE	CORRECTION
- Premature wear of U-joints and/or bluish color of cross journals.	- Insufficient lubrication.  - Excessive working angle.	- Follow lubrication recommendations. - Replace defective U-joints. - Make sure the Snowblower inlet face is perpendicular to the ground and if possible readjust 3-point hitch in order to position the Snowblower further away from tractor.
- Gripping or premature wear of telescoping members.	- Too much sliding under load.  - Tube overlap too-short: minimum recommended is 6". - Insufficient lubrication. - Contaminants (sand, etc.).	- Avoid raising Snowblower while in operation.  - Readjust 3-point hitch in order to position the snowblower closer to the tractor. - Follow lubrication recommendations. - Replace defective telescopic members.
- Damaged or jammed locking pin or bolt.	- Pin or orifice contaminated by sand, ice, etc. - Telescoping members too long, exerting pressure on locking device.	- Clean and grease.  - Readjust 3-point hitch in order to position the Snowblower further away from tractor or shorten tubes.
- Premature wear of guard tube bearing ring.	- Lack of lubrication. - Wrong installation of guard chain. - Part of the guard in contact with the equipment.	- Follow lubrication instructions. - Adjust chain to prevent interference between guard & equipment. - Replace worn or damaged bearing rings.
- Cut or deformed safety guard tubes.	- Tubes in contact with the equipment.	- Eliminate any interference between tubes and equipment or tractor. - Replace damaged tubes.

# ***TROUBLESHOOTING (cont'd)***

## ***SNOWBLOWER***

<b>PROBLEM</b>	<b>POSSIBLE CAUSE</b>	<b>CORRECTION</b>
- The snow is not being thrown as far as usual.	- Tractor RPM too low. - Gap too wide between impeller blade tip and drum outlet wall. - Insufficient tractor HP.	- Raise P.T.O. speed to a minimum of 540 RPM. - Adjust impeller blades closer to drum outlet (1/8" to 3/16"). - Reduce travel speed.
- Frequent plugging of discharge chute.	- Tractor RPM too low. - Tractor RPM reduced too early with snow still in the Snowblower.	- Raise P.T.O. speed to a minimum of 540 RPM. - Make sure the Snowblower is completely empty before reducing RPM, especially on tractors with foot controlled RPM.
	- Slippage of PTO clutch mechanism. - Wet snow condition.	- Repair clutch. - Reduce travel speed.
- The impeller will not turn.	- Shear bolt broken on drive shaft.	- Replace shear bolt.
- The auger will not turn.	- Shear bolt broken on drive shaft. - Shear bolt broken on auger drive shaft. - Broken drive chain.	- Replace shear bolt. - Replace shear bolt. - Fix or replace chain.
- The rotating drum will not turn.	- Rotating drum shear bolt broken. - Ice accumulation. - Wrong hydraulic connections.	- Replace shear bolt. - Remove ice. - Check hydraulic connections.
- The chute will not turn.	- Ice accumulation. - Wrong hydraulic connections.	- Remove ice. - Check hydraulic connections.

**8**



# SPECIFICATIONS

Snowblower model		P-540	P-540 TRC	P-620	P-620 TRC	P-680	P-680 TRC	P-720	P-720 TRC
Horse power recommended (HP) min - max		18-25	18-25	18-25	18-25	25-35	25-35	25-35	25-35
Working width	(inches)	54"	54"	62"	62"	68"	68"	72"	72"
	(centimeters)	137	137	157	157	173	173	183	183
Cutting height	(inches)	28"	28"	28"	28"	30"	30"	30"	30"
	(centimeters)	71	71	71	71	76	76	76	76
Impeller diameter	(inches)	22"	22"	22"	22"	24"	24"	24"	24"
	(centimeters)	56	56	56	56	61	61	61	61
Depth of drum	(inches)	9"	9"	9"	9"	9"	9"	9"	9"
	(centimeters)	22.9	22.9	22.9	22.9	22.9	22.9	22.9	22.9
Impeller blades		4	4	4	4	4	4	4	4
Size of impeller shaft	(inches)	1 1/4"	1 1/4"	1 1/4"	1 1/4"	1 9/16"	1 9/16"	1 9/16"	1 9/16"
	(centimeters)	3.18	3.18	3.18	3.18	3.97	3.97	3.97	3.97
Impeller RPM		540	540	540	540	540	540	540	540
Number of augers		1	1	1	1	1	1	1	1
Main auger diameter	(inches)	16"	16"	16"	16"	16"	16"	16"	16"
	(centimeters)	41	41	41	41	41	41	41	41
Upper auger 13" (33 cm) diameter		-	-	-	-	-	-	-	-
Drive chain - main auger		50	50	50	50	60	60	60	60
Oil bath sealed gear box		Std.	Std.	Std.	Std.	Std.	Std.	Std.	Std.
Choice of chute rotation mechanism	Manuel	Avail.	Avail.	Avail.	Avail.	Avail.	Avail.	Avail.	Avail.
	Hydraulique C (cylinder)	-	-	-	-	-	-	-	-
	Hydraulique M (motor)	Avail.	Avail.	Avail.	Avail.	Avail.	Avail.	Avail.	Avail.
Number of shear bolt		1	1	1	1	1	1	1	1
Heavy duty 3-point		-	-	-	-	-	-	-	-
Hitch category		1	1	1	1	1	1	1	1
Balanced impeller		Std.	Std.	Std.	Std.	Std.	Std.	Std.	Std.
Balanced auger		Std.	Std.	Std.	Std.	Std.	Std.	Std.	Std.
Drum rotation mechanism	Hydraulic C (cylinder)	-	-	-	-	-	-	-	-
	Hydraulic M (motor)	-	Std.	-	Std.	-	Std.	-	Std.
1000 @ 540 RPM reducer		-	-	-	-	-	-	-	-
Scraper blade	Steel - not reversible	Std.	Std.	Std.	Std.	Std.	Std.	Std.	Std.
	Carbon steel - not reversible	Opt.	Opt.	Opt.	Opt.	Opt.	Opt.	Opt.	Opt.
Adjustable skid shoes	Standard steel	Std.	Std.	Std.	Std.	Std.	Std.	Std.	Std.
	Carbon steel	-	-	-	-	-	-	-	-
Full flight upper auger		-	-	-	-	-	-	-	-
Semi-industrial chute		Opt.	Opt.	Opt.	Opt.	Opt.	Opt.	Opt.	Opt.
Industrial chute		-	-	-	-	-	-	-	-
24" (61 cm) chute extension		-	-	-	-	-	-	-	-
48" (122 cm) chute extension		-	-	-	-	-	-	-	-
Choice of deflector adjustment	Rod and tube	Avail.	Avail.	Avail.	Avail.	Avail.	Avail.	Avail.	Avail.
	Cylinder	Avail.	Avail.	Avail.	Avail.	Avail.	Avail.	Avail.	Avail.
Bearing / ductile iron casing		-	-	-	-	-	-	-	-
Height - Impeller center	(inches)	14"	14"	14"	14"	15"	15"	15"	15"
	(centimeters)	35.6	35.6	35.6	35.6	38.1	38.1	38.1	38.1
Lateral blades		Opt.	Opt.	Opt.	Opt.	Opt.	Opt.	Opt.	Opt.
P.T.O. shaft standard		No. 2	No. 2	No. 2	No. 2	No. 4	No. 4	No. 5	No. 5
P.T.O. shaft intensive use		Opt.	Opt.	Opt.	Opt.	Opt.	Opt.	Opt.	Opt.
Weight (approx.)	(lbs)	550	655	575	680	670	775	695	800
	(kg)	248	295	259	306	302	349	313	360

Design and specifications subject to change without notice.

# SNOWBLOWERS P-540 P-620 P-680 P-720

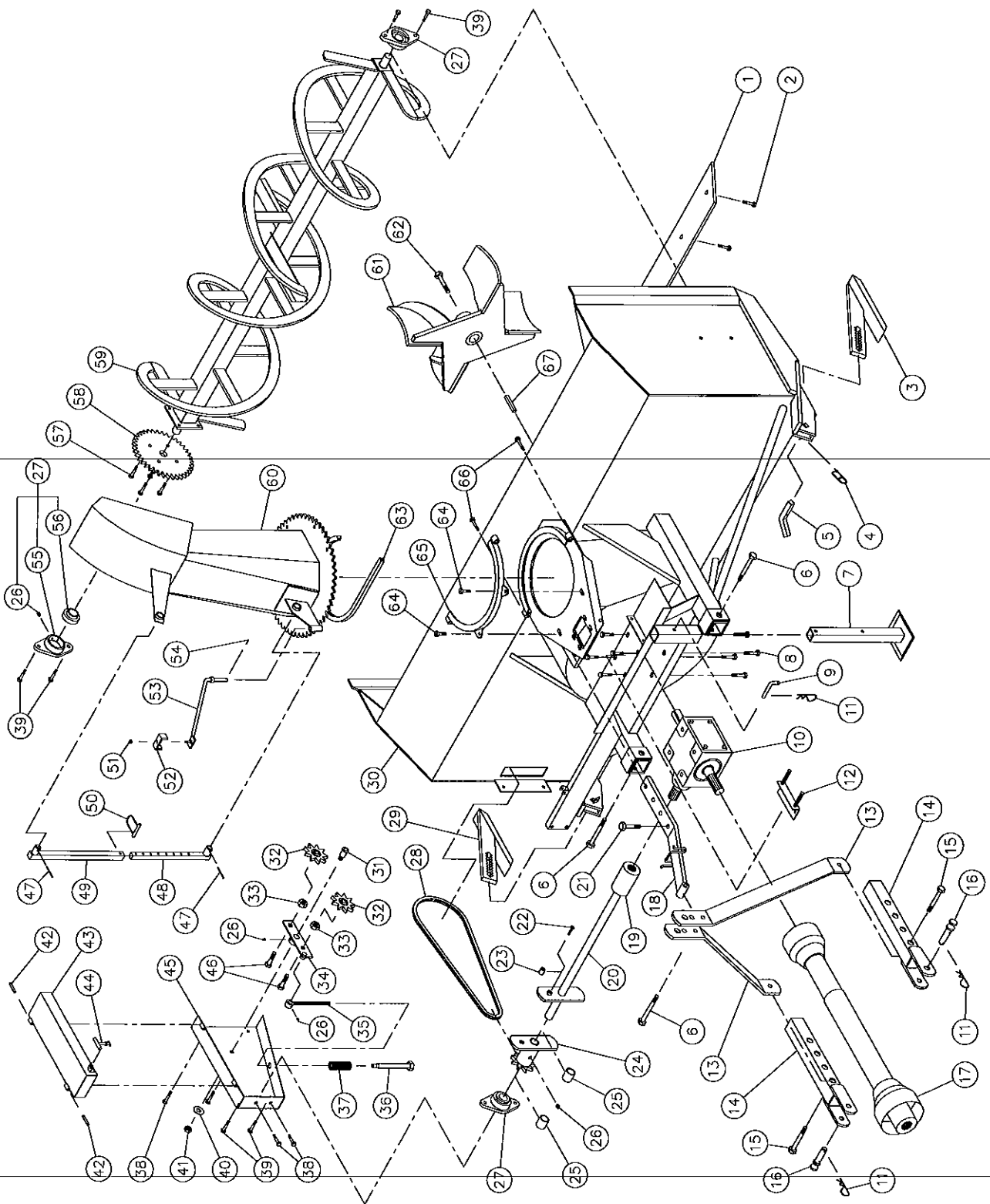

10

# SNOWBLOWERS P-540 P-620 P-680 P-720 (cont'd)

REF.	PART #	DESCRIPTION	QTY			
			P-540	P-620	P-680	P-720
1	140-01251	Scraper blade (not reversible) 3/8" x 2 1/2" x 50 1/4" lg	1	-	-	-
1	140-01261	Scraper blade (not reversible) 3/8" x 2 1/2" x 58 1/4" lg	-	1	-	-
1	140-01271	Scraper blade (not reversible) 3/8" x 2 1/2" x 64 1/4" lg	-	-	1	-
1	140-01281	Scraper blade (not reversible) 3/8" x 2 1/2" x 68 1/4" lg	-	-	-	1
2	125-0715	Plow bolt 7/16" NC x 1 1/2" lg + nut & lock washer	5	6	7	7
3	6479-D	Skid shoe (right side)	1	1	1	1
4	6561	Safety square pin 2mm x 58 mm	2	2	2	2
5	140-03261	Skid shoes lock	2	2	2	2
6	Std.	Bolt 1/2" NC x 3 1/2" lg + nylon locknut	3	3	3	3
7	6520	Storage support	1	1	1	1
8	Std.	Bolt 3/8" NC x 5 1/2" lg + nylon locknut & 6 flat washer	4	4	-	-
8	Std.	Bolt 1/2" NC x 1" lg + lock washer & 6 flat washer	-	-	8	8
9	6521	Storage support pin	1	1	1	1
10	6451	Gear box T281	1	1	-	-
10	8251	Gear box T27D	-	-	1	1
11	Std.	Hitch pin clip 5/32"	3	3	3	3
12	6522	Adjustment plate for gear box + 4 nuts 3/8" NC	1	1	-	-
12	8199	Adjustment plate for gear box + 4 nuts 1/2" NC	-	-	1	1
13	6517	3-point side bar	2	2	-	-
13	6519	3-point side bar	-	-	2	2
14	6252	Lower hitch (right & left)	2	2	2	2
15	Std.	Bolt 1/2" NC x 3" lg + nylon locknut	2	2	2	2
16	6253	Pin category 1	2	2	2	2
17	6408	P.T.O. shaft	1	1	-	-
17	6248	P.T.O. shaft	-	-	1	-
17	8114	P.T.O. shaft	-	-	-	1
18	6504	Upper hitch	1	1	-	-
18	6505	Upper hitch	-	-	1	1
19	6466	Splined adaptor 1 1/4"-19	1	1	1	1
20	6441	Auger drive shaft 20 7/8" lg overall (including no. 19 & 23)	1	-	-	-
20	6442	Auger drive shaft 24 7/8" lg overall (including no. 19 & 23)	-	1	-	-
20	6443	Auger drive shaft 24 7/16" lg overall (including no. 19 & 23)	-	-	1	-
20	6456	Auger drive shaft 26 7/16" lg overall (including no. 19 & 23)	-	-	-	1
21	Std.	Bolt 1/2" NC x 1 1/2" lg + nylon locknut	1	1	1	1
22	Std.	Bolt 1/4" NC x 2" lg grade 5 + nylon locknut	1	1	1	1
23	150-01491	Welded bushing 1/4" i.d. x 7/8" o.d. x 3/4" lg	2	2	2	2
24	6287	Sprocket #50 + shearplate	1	1	-	-
24	6260	Sprocket #60 + shearplate	-	-	1	1
25	8009	Brass bushing 1 1/4" i.d. x 1 1/2" o.d. x 1 3/16" lg	2	2	2	2
26	Std.	Grease fitting 1/4"-28 straight	6	6	6	6
27	6261	Bearing 1" + flange	3	3	3	3
28	ASA50-5	Chain #50 x 59 7/8" lg	1	1	-	-
28	26A50	Connecting link no. 50	1	1	-	-
28	59-50	Offset link no. 50	1	1	-	-
28	ASA60-5.4	Chain #60 x 64 3/4" lg	-	-	1	1
28	26A60	Connecting link no. 60	-	-	1	1
28	59-60	Offset link no. 60	-	-	1	1
29	110-04361	Skid shoe (left side)	1	1	1	1
30	---	Frame P-540	1	-	-	-
30	---	Frame P-620	-	1	-	-
30	---	Frame P-680	-	-	1	-
30	---	Frame P-720	-	-	-	1
31	150-00461	Idle clevis pin	1	1	-	-

**10**

# SNOWBLOWERS P-540 P-620 P-680 P-720 (cont'd)

REF.	PART #	DESCRIPTION	QTY			
			P-540	P-620	P-680	P-720
31	150-00501	Idler clevis pin .....	-	-	1	1
32	8122	Idler pulley .....	2	2	-	-
32	8186	Idler sprocket #60 .....	-	-	2	2
33	160-01611	Spacer .....	2	2	-	-
33	Std.	Nut 5/8" NC .....	-	-	2	2
34	110-01971	Idler .....	1	1	-	-
34	110-02151	Idler .....	-	-	1	1
35	110-01991	Threaded rod for idler adjustment + nut 7/16" NC .....	1	1	-	-
35	110-02141	Threaded rod for idler adjustment + nut 7/16" NC .....	-	-	1	1
36	110-01981	Threaded tube for idler adjustment .....	1	1	1	1
37	6538	Compression spring .....	1	1	1	1
38	Std.	Bolt 3/8" NC x 1" lg + nylon locknut .....	4	4	4	4
39	Std.	Bolt 1/2" NC x 1 1/4" lg + nylon locknut thin .....	6	6	6	6
40	Std.	Flat washer 1/2" .....	1	1	1	1
41	346-40500	Nylon locknut 1/2" NC mince .....	1	1	1	1
42	Std.	Roll pin 5/16" x 2" lg .....	2	2	2	2
43	110-02021	Chain guard cover .....	1	1	-	-
43	110-02161	Chain guard cover .....	-	-	1	1
44	8125	Rubber fastener .....	1	1	1	1
45	110-02231	Chain guard .....	1	1	-	-
45	110-02251	Chain guard .....	-	-	1	1
46	Std.	Bolt 1/2" NC x 2 1/2" lg + nylon locknut .....	2	2	-	-
46	Std.	Bolt 1/2" NC x 2" lg + nylon locknut .....	-	-	2	2
47	Std.	2 cotter pin 5/32" x 2" lg .....	opt.	opt.	opt.	opt.
48	6438	Chute adjusting rod .....	opt.	opt.	opt.	opt.
49	6439	Chute adjusting tube .....	opt.	opt.	opt.	opt.
50	8112	Lock pin 1/4" .....	opt.	opt.	opt.	opt.
51	Std.	Nylon locknut 5/16" NC .....	opt.	opt.	opt.	opt.
52	140-00881	Hoses mounting plate .....	opt.	opt.	opt.	opt.
53	110-01121	Mounting support plate .....	opt.	opt.	opt.	opt.
54	Std.	Cotter pin 1/8" x 1" lg .....	opt.	opt.	opt.	opt.
55	6454	Flange FL205 .....	3	3	3	3
56	6455	Bearing 1" UC205-16 .....	3	3	3	3
57	Std.	Bolt 3/8" NC x 1 1/4" lg + nylon locknut .....	4	4	4	4
58	6288	Sprocket 50 A36 T 1" $\phi$ .....	1	1	-	-
58	6272	Sprocket 60 A38 T 1 1/4" $\phi$ .....	-	-	1	1
59	6281	Auger P-540 .....	1	-	-	-
59	6282	Auger P-620 .....	-	1	-	-
59	6453	Auger P-680 .....	-	-	1	-
59	6457	Auger P-720 .....	-	-	-	1
60	120-01501	Chute .....	1	1	1	1
61	110-02241	Impeller 22" $\phi$ 4 blades .....	1	1	-	-
61	110-02261	Impeller 24" $\phi$ 4 blades .....	-	-	1	1
62	Std.	Impeller cap screw 3/8" NC x 1" lg (assembled with locktite 242) + lock washer .....	1	1	-	-
62	Std.	Impeller cap screw 5/8" NC x 1 1/2" lg (assembled with locktite 242) + lock washer .....	-	-	1	1
63	6471	U-shaped UHMW $\pm$ 12" $\phi$ i.d. .....	1	1	1	1
64	Std.	Bolt 7/16" NC x 1 1/4" lg + nylon lock nut & flat washer .....	2	2	2	2
65	110-02001	Retaining bracket .....	1	1	1	1
66	Std.	Bolt 5/16" NC x 2 1/2" lg + nylon locknut .....	2	2	2	2
67	6276	Square key 1/4" x 1/4" x 1 3/4" lg .....	1	1	-	-
67	8030	Square key 3/8" x 3/8" x 3 1/2" lg .....	-	-	1	1

# SNOWBLOWERS P-540TRC P-620TRC P-680TRC P-720TRC

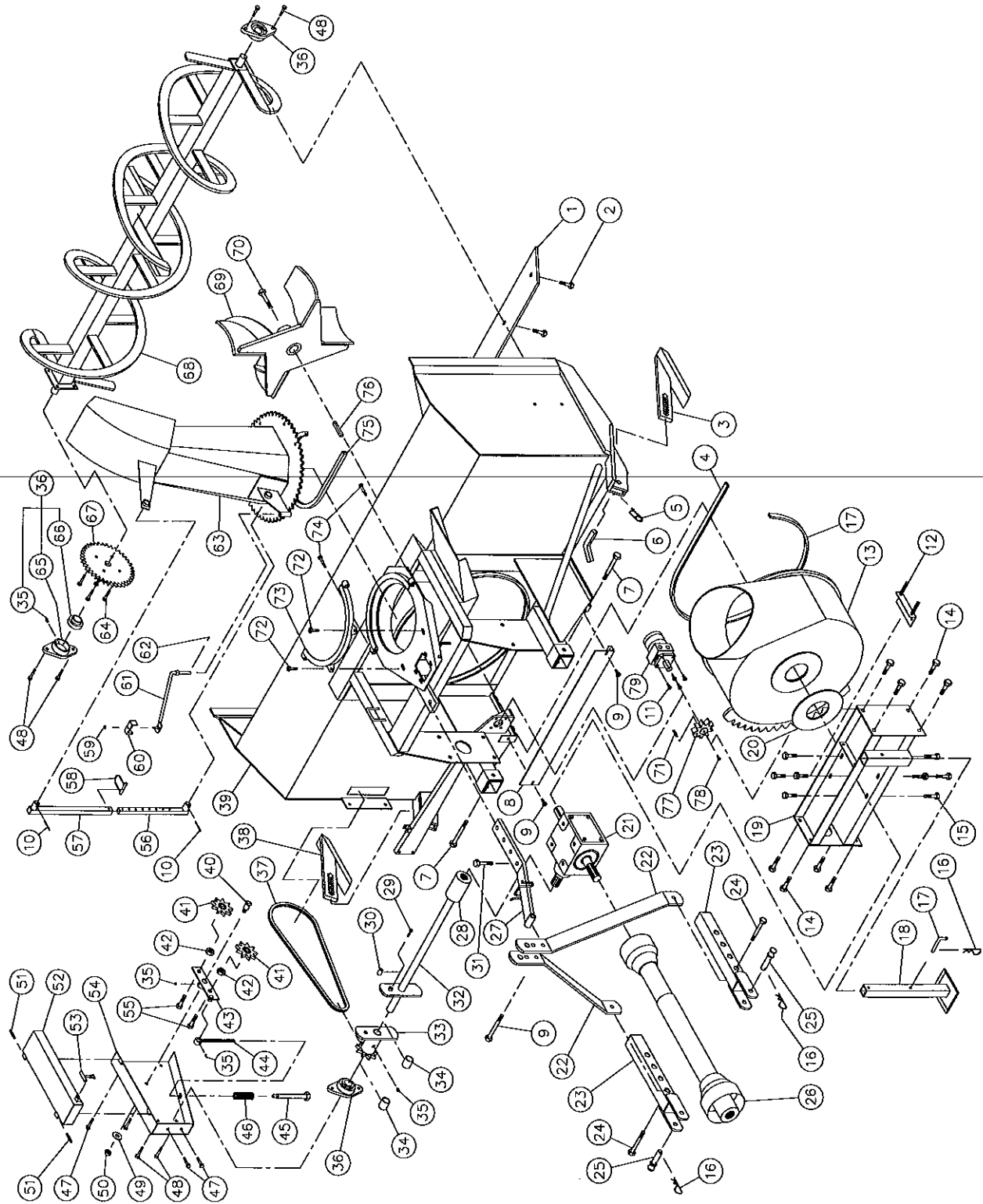

# SNOWBLOWERS P-540TRCP-620TRCP-680TRCP-720TRC (cont'd)

REF.	PART #	DESCRIPTION	P-540TRC	P-620TRC	P-680TRC	P-720TRC
1	140-01251	Scaper blade (not reversible) 3/8" x 2 1/2" x 50 3/4" lg .....	1	-	-	-
1	140-01261	Scaper blade (not reversible) 3/8" x 2 1/2" x 58 1/4" lg .....	-	1	-	-
1	140-01271	Scaper blade (not reversible) 3/8" x 2 1/2" x 64 1/4" lg .....	-	-	1	-
1	140-01281	Scaper blade (not reversible) 3/8" x 2 1/2" x 68 1/4" lg .....	-	-	-	1
2	125-0715	Plow bolt 7/16" NC x 1 1/2" lg + nut & lock washer .....	5	6	7	7
3	110-05541	Skid shoe (right side) .....	1	1	1	1
4	6514	U-shaped UHMW 3/8" x 9/16" x 70 5/8" lg .....	1	1	-	-
4	6515	U-shaped UHMW 3/8" x 9/16" x 77" lg .....	-	-	1	1
5	6561	Safety lock 2 mm x 58 mm .....	2	2	2	2
6	140-03261	Skid shoes lock .....	2	2	2	2
7	Std.	Bolt 1/2" NC x 3 1/2" lg + nylon locknut .....	3	3	3	3
8	130-03221	Guard for ring gear segment .....	1	1	-	-
8	130-03231	Guard for ring gear segment .....	-	-	1	1
9	Std.	Bolt 7/16" NC x 1" lg + nylon locknut & flat washer .....	2	2	2	2
10	Std.	Cotter pin 5/32" x 2" lg (2) .....	opt.	opt.	opt.	opt.
11	Std.	Bolt 3/8" NC x 1" lg + lockwasher .....	4	4	4	4
12	6522	Adjustment plate for gear box + 4 nuts 3/8" NC .....	1	1	-	-
12	8199	Adjustment plate for gear box + 4 nuts 1/2" NC .....	-	-	1	1
13	110-02551	Rotary drum 22" ø .....	1	1	-	-
13	110-02571	Rotary drum 24" ø .....	-	-	1	1
14	Std.	Bolt 1/2" NC x 1 1/2" lg + nylon locknut .....	8	8	-	-
14	Std.	Bolt 5/8" NC x 1 1/2" lg + nylon locknut .....	-	-	8	8
15	Std.	Bolt 3/8" NC x 5 1/2" lg + nylon locknut & 2 flat washers .....	4	4	-	-
15	Std.	Bolt 1/2" NC x 1" lg + lock washer & flat washer .....	-	-	8	8
16	Std.	Hitch pin clip 5/32" .....	3	3	3	3
17	6521	Storage support pin .....	1	1	1	1
18	6520	Storage support .....	1	1	1	1
19	110-05611	Gear box support .....	1	1	-	-
19	110-05601	Gear box support .....	-	-	1	1
20	6530	UHMW flat washer 3/16" x 5" i.d. x 6 1/2" o.d. ....	1	1	-	-
20	8232	UHMW flat washer 3/16" x 4 5/8" i.d. x 8 1/8" o.d. ....	-	-	1	1
21	6451	Gear box T281 .....	1	1	-	-
21	8251	Gear box T-27D .....	-	-	1	1
22	6516	3-point side bar .....	2	2	-	-
22	6518	3-point side bar .....	-	-	2	2
23	6252	Lower hitch (right and left) .....	2	2	2	2
24	Std.	Bolt 1/2" NC x 3" lg + nylon locknut .....	2	2	2	2
25	6253	Pin category 1 .....	2	2	2	2
26	6408	P.T.O. shaft .....	1	1	-	-
26	6248	P.T.O. shaft .....	-	-	1	-
26	8114	P.T.O. shaft .....	-	-	-	1
27	6502	Upper hitch .....	1	1	-	-
27	6503	Upper hitch .....	-	-	1	1
28	6466	Splines adaptor 1 1/4" - 19 .....	1	1	1	1
29	Std.	Safety shear bolt 1/4" NC x 2" lg grade 5 + nylon locknut .....	1	1	1	1
30	150-01491	Welded bushing 1/4" i.d. x 3/4" o.d. x 3/4" lg .....	4	4	4	4
31	Std.	Bolt 1/2" NC x 1 1/2" lg + nylon locknut .....	1	1	1	1
32	6441	Auger drive shaft 20 7/8" lg overall (including no. 28 & 30) .....	1	-	-	-
32	6442	Auger drive shaft 24 7/8" lg overall (including no. 28 & 30) .....	-	1	-	-
32	6443	Auger drive shaft 24 7/16" lg overall (including no. 28 & 30) .....	-	-	1	-
32	6456	Auger drive shaft 26 7/16" lg overall (including no. 28 & 30) .....	-	-	-	1

10

# SNOWBLOWERS P-540TRCP-620TRCP-680TRCP-720TRC (cont'd)

REF.	PART #	DESCRIPTION	QTY			
			P-540TRC	P-620TRC	P-680TRC	P-720TRC
33	6287	Sprocket #50 + shearplate .....	1	1	-	-
33	6260	Sprocket #60 + shearplate .....	-	-	1	1
34	8009	Brass bushing 1 1/4" i.d. x 1 1/2" o.d. x 1 3/16" lg .....	2	2	2	2
35	Std.	Grease fitting 1/4"-28 straight .....	6	6	6	6
36	6261	Bearing 1" + flange .....	3	3	3	3
37	ASA50-5	Chain #50 .....	1	1	-	-
37	26A50	Connecting link no. 50 .....	1	1	-	-
37	59-50	Offset link no. 50 .....	1	1	-	-
37	ASA60-5.4	Chain #60 .....	-	-	1	1
37	26A60	Connecting link no. 60 .....	-	-	1	1
37	59-60	Offset link no. 60 .....	-	-	1	1
38	110-04361	Skid shoe (left side) .....	1	1	1	1
39	---	Frame P-540TRC .....	1	-	-	-
39	---	Frame P-620TRC .....	-	1	-	-
39	---	Frame P-680TRC .....	-	-	1	-
39	---	Frame P-720TRC .....	-	-	-	1
40	150-00461	Idler clevis pin .....	1	1	-	-
40	150-00501	Idler clevis pin .....	-	-	1	1
41	8122	Idler pulley #50 .....	2	2	-	-
41	8186	Idler sprocket #60 .....	-	-	2	2
42	160-01611	Spacer .....	2	2	-	-
42	Std.	Nut 5/8" NC .....	-	-	2	2
43	110-01971	Idler .....	1	1	-	-
43	110-02151	Idler .....	-	-	1	1
44	110-01991	Threaded rod for idler adjustment + nut 7/16" NC .....	1	1	-	-
44	110-02141	Threaded rod for idler adjustment + nut 7/16" NC .....	-	-	1	1
45	110-01981	Threaded tube for idler adjustment .....	1	1	1	1
46	6538	Compression spring .....	1	1	1	1
47	Std.	Bolt 3/8" NC x 1" lg + nylon locknut .....	4	4	4	4
48	Std.	Bolt 1/2" NC x 1 1/4" lg + nylon locknut thin .....	6	6	6	6
49	Std.	Flat washer 1/2" .....	1	1	1	1
50	346-40500	Nylon locknut 1/2" NC thin .....	1	1	1	1
51	Std.	Roll pin 5/16" x 2" lg .....	2	2	2	2
52	110-02021	Chain guard cover .....	1	1	-	-
52	110-02161	Chain guard cover .....	-	-	1	1
53	8125	Rubber fastener .....	1	1	1	1
54	110-02231	Chain guard .....	1	1	-	-
54	110-02251	Chain guard .....	-	-	1	1
55	Std.	Bolt 1/2" NC x 2 1/2" lg + nylon locknut .....	2	2	-	-
55	Std.	Bolt 1/2" NC x 2" lg + nylon locknut .....	-	-	2	2
56	6438	Chute adjusting rod .....	opt.	opt.	opt.	opt.
57	6439	Chute adjusting tube .....	opt.	opt.	opt.	opt.
58	8112	Lock pin .....	opt.	opt.	opt.	opt.
59	Std.	Nylon locknut 5/16" NC .....	opt.	opt.	opt.	opt.
60	140-00881	Hoses mounting plate .....	opt.	opt.	opt.	opt.
61	110-01121	Mounting support plate .....	opt.	opt.	opt.	opt.
62	Std.	Cotter pin 1/8" x 1" lg .....	opt.	opt.	opt.	opt.
63	120-01501	Chute .....	1	1	1	1
64	Std.	Bolt 3/8" NC x 1 1/4" lg + nylon locknut .....	4	4	4	4
65	6454	Flange .....	3	3	3	3
66	6455	Bearing 1" UC205-16 .....	3	3	3	3

# SNOWBLOWERS P-540TRCP-620TRCP-680TRCP-720TRC (cont'd)

REF.	PART #	DESCRIPTION	QTY			
			P-540TRC	P-620TRC	P-680TRC	P-720TRC
67	6288	Sprocket #50A36 T 1" .....	1	1	-	-
67	6272	Sprocket #60A38 T 1¼" .....	-	-	1	1
68	6281	Auger P-540TRC .....	1	-	-	-
68	6282	Auger P-620TRC .....	-	1	-	-
68	6453	Auger P-680TRC .....	-	-	1	-
68	6457	Auger P-720TRC .....	-	-	-	1
69	110-02241	Impeller 22" ø 4 blades .....	1	1	-	-
69	110-02261	Impeller 24" ø 4 blades .....	-	-	1	1
70	Std.	Impeller cap screw 3/8" NC x 1" lg (assembled with lockite 242) + lock washer .....	1	1	-	-
70	Std.	Impeller cap screw 5/8" NC x 2" lg (assembled with lockite 242) + lock washer .....	-	-	1	1
71	Std.	Bolt 1/2" NC x 1 1/4" lg + nylon locknut .....	2	2	2	2
72	Std.	Bolt 7/16" NC x 1 1/4" lg + nylon locknut & flat washer .....	2	2	2	2
73	110-02001	Retaining bracket .....	1	1	1	1
74	Std.	Bolt 5/16" NC x 2 1/2" lg + nylon locknut .....	2	2	2	2
75	6471	U-shaped UHMW ± 12" i.d. ....	1	1	1	1
76	6276	Square key ¼" x ¼" x 1 3/4" lg .....	1	1	-	-
76	8030	Square key 3/8" x 3/8" x 3 1/2" lg .....	-	-	1	1
77	- - -	Key (as motor requirement) .....	1	1	1	1
78	Std.	Bolt 1/4" NC x 3/4" lg + lock washer .....	1	1	1	1
79	DH100	Hydraulic motor for rotary drum .....	1	1	1	1



# MANUAL CHUTE KIT MR-4864

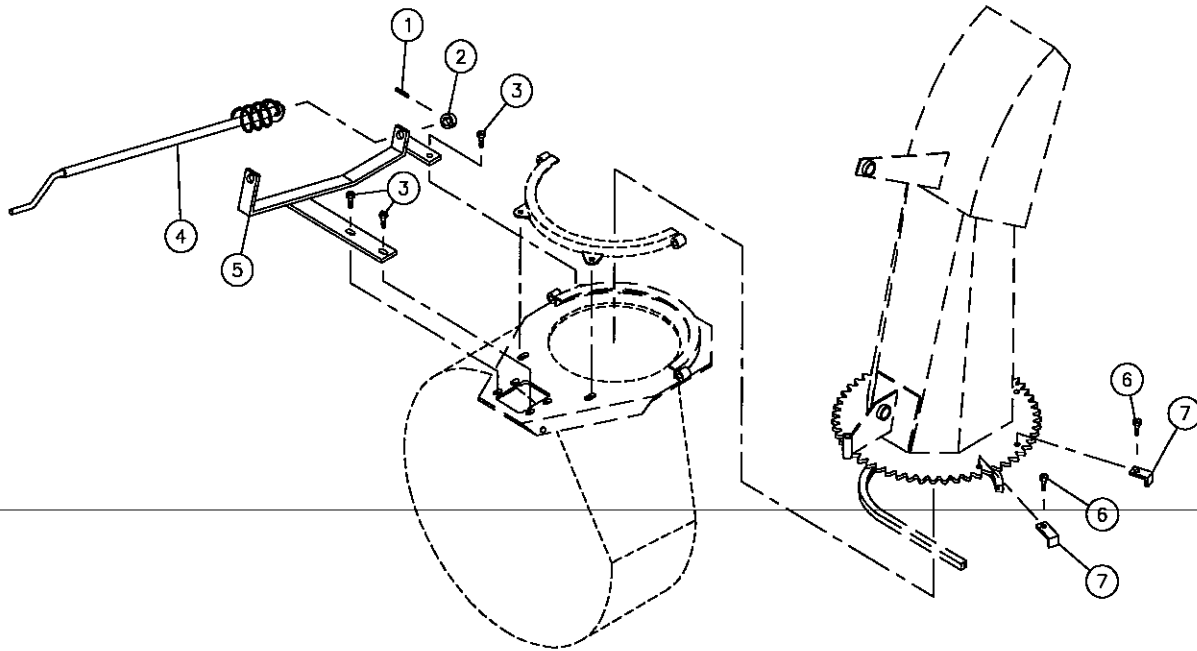

REF.	PART #	DESCRIPTION	QTY
1	Std.	Roll pin 1/4" x 1 1/2" .....	1
2	160-04021	Crank stopper .....	1
3	Std.	Bolt 7/16" NC x 1 1/2" lg + nylon locknut & flat washer .....	3
4	110-08061	Crank .....	1
5	110-08071	Crank support .....	1
6	Std.	Bolt 7/16" x 1 1/4" lg + nylon locknut .....	2
7	140-05661	Stopper .....	2

# HYDRAULIC CHUTE KIT *Motor* SP-4864

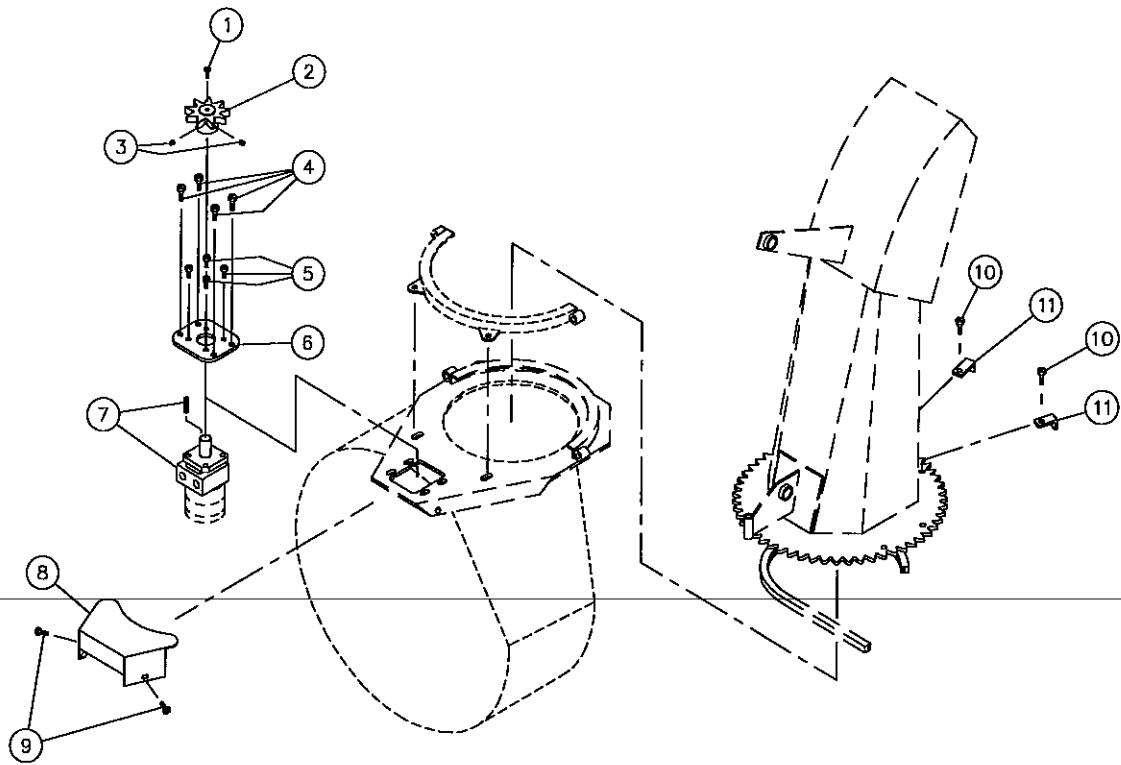

REF.	PART #	DESCRIPTION	QTY
1	Std.	Bolt 1/4" NC x 3/4" lg + locknut .....	1
2	110-04182	Sprocket (9 teeth) .....	1
3	Std.	Allen set screw 3/8" NC x 3/8" lg .....	2
4	Std.	Bolt 7/16" NC x 1 1/2" lg + nylon locknut & flat washer .....	4
5	Std.	Bolt 3/8" NC x 1" lg + lock washer .....	4
6	130-07911	Motor mounting plate .....	1
7	---	Hydraulic motor (DH125 or DH250) + key .....	1
8	130-08561	Guard .....	1
9	Std.	Bolt 5/16" NC x 1" lg + nylon locknut & flat washer .....	2
10	Std.	Bolt 7/16" NC x 1 1/4" lg + nylon locknut .....	2
11	140-05661	Stopper .....	2

# SEMI-INDUSTRIAL CHUTE PSI-4864

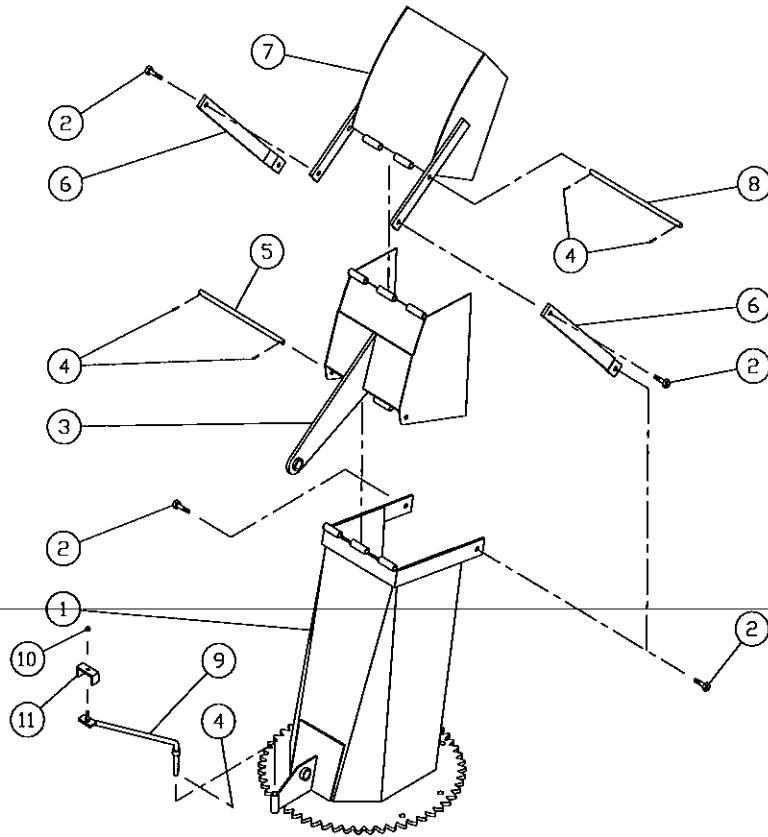

REF.	PART #	DESCRIPTION	QTY
1	110-02282	Chute base.....	1
2	Std.	Bolt 7/16" x 1 1/4" lg + nylon locknut.....	4
3	6532	Lower chute deflector.....	1
4	Std.	Cotter pin 1/8" x 1" lg.....	4
5	6533	Lower chute deflector pin.....	1
6	6534	Connecting rod.....	2
7	6535	Upper chute deflector.....	1
8	6536	Upper chute deflector pin.....	1
9	110-01121	Mounting support plate.....	1
10	Std.	Nylon locknut 5/16" NC.....	1
11	140-00881	Hoses mounting plate.....	1

# P.T.O. SHAFT #6408-E (T20)

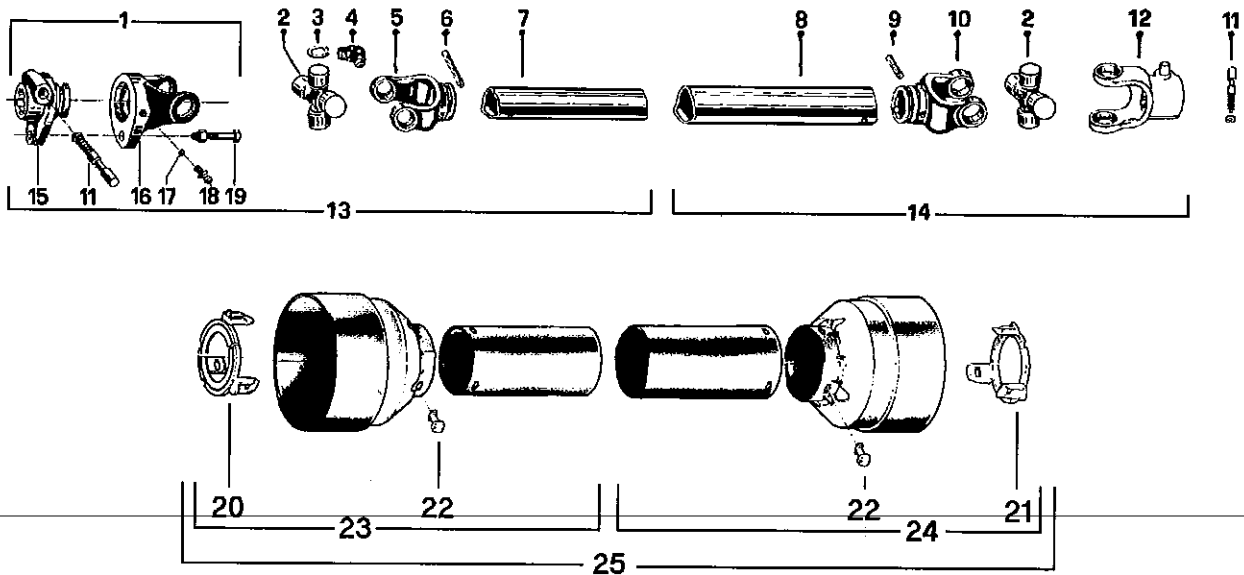

REF.	PART #	DESCRIPTION	QTY
1	6201	Quick disconnect yoke assembly .....	1
2	6208	U-joint + 4 retaining rings + 1 grease fitting .....	2
3	6203	Retaining ring .....	8
4	8110	Grease fitting .....	2
5	6434	Yoke for inner tube .....	1
6	6433	Stopper for inner tube .....	1
7	6432	Inner tube .....	1
8	6431	Outer tube .....	1
9	6344	Stopper for outer tube .....	1
10	6430	Yoke for outer tube .....	1
11	8068-E	Yoke stopper 1 11/16" .....	2
12	6409	Yoke with hole 1 3/8"-6 splines + yoke stopper .....	1
13	6224	P.T.O. section, side with safety shear bolt, inner part, without protector .....	1
14	6225	P.T.O. section, side without safety shear bolt, outer part, without protector .....	1
15	6202	Adaptor .....	1
16	6204	Yoke and shearplate .....	1
17	6205	Ball .....	17
18	6206	Grease fitting .....	1
19	6207	Safety shear bolt M6 x 40mm .....	1
20	6219-E	Bearing ring for inner guard tube .....	1
21	6218-E	Bearing ring for outer guard tube .....	1
22	8109	Stopper .....	6
	6221	Inner shield .....	1
24	6220	Outer shield .....	1
25	6222	Complete shield .....	1

10

# P.T.O. SHAFT #6248-EG (T40)

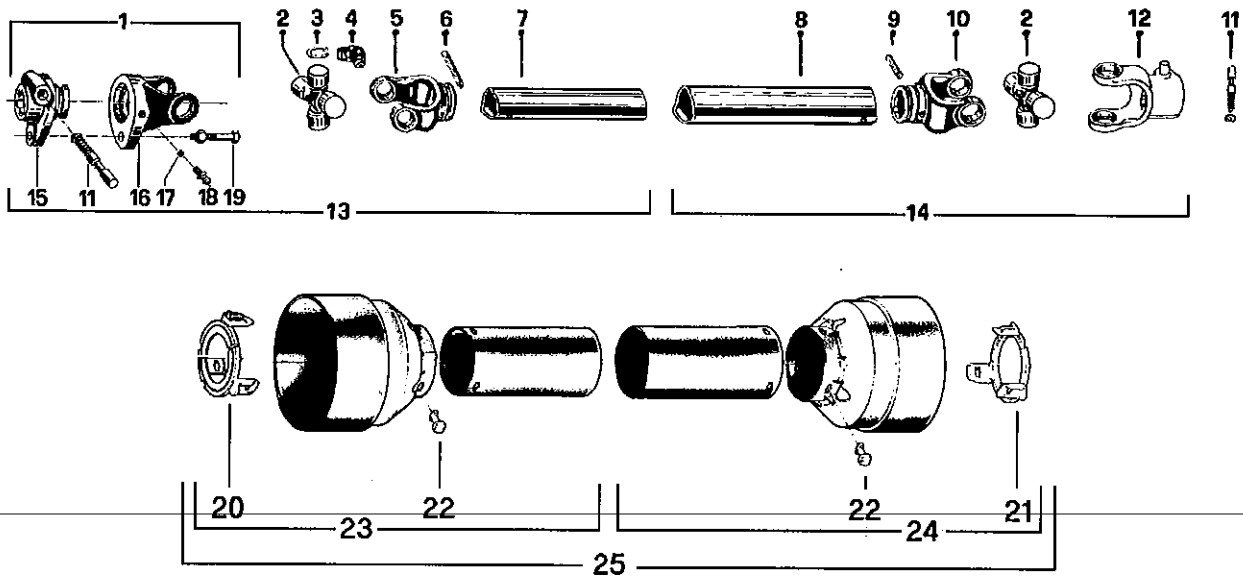

REF.	PART #	DESCRIPTION	QTY
1	6232	Quick disconnect yoke assembly .....	1
2	6239	U-joint + 4 retaining rings + 1 grease fitting .....	2
3	6234	Retaining ring .....	8
4	8110	Grease fitting .....	2
5	6353	Yoke for inner tube .....	1
6	6344	Stopper for inner tube .....	1
7	6343	Inner tube .....	1
8	6342	Outer tube .....	1
9	6341	Stopper for outer tube .....	1
10	6340	Yoke for outer tube .....	1
11	8068-E	Yoke stopper 1 11/16" .....	2
12	6354	Yoke with hole 1 3/8"-6 splines + yoke stopper .....	1
13	6236	P.T.O. section, side with safety shear bolt, inner part, without protector .....	1
14	6237	P.T.O. section, side without safety shear bolt, outer part, without protector .....	1
15	6233	Adaptor .....	1
16	6235	Yoke and shearplate .....	1
17	8070	Ball .....	17
18	8071	Grease fitting .....	1
19	6238	Safety shear bolt M6 x 40mm .....	1
20	6349-E	Bearing ring for inner guard tube .....	1
21	6348-E	Bearing ring for outer guard tube .....	1
22	8109	Stopper .....	6
23	6351-E	Inner shield .....	1
24	6350-E	Outer shield .....	1
25	6352	Complete shield .....	1

# P.T.O. SHAFT 8114-EG (T50)

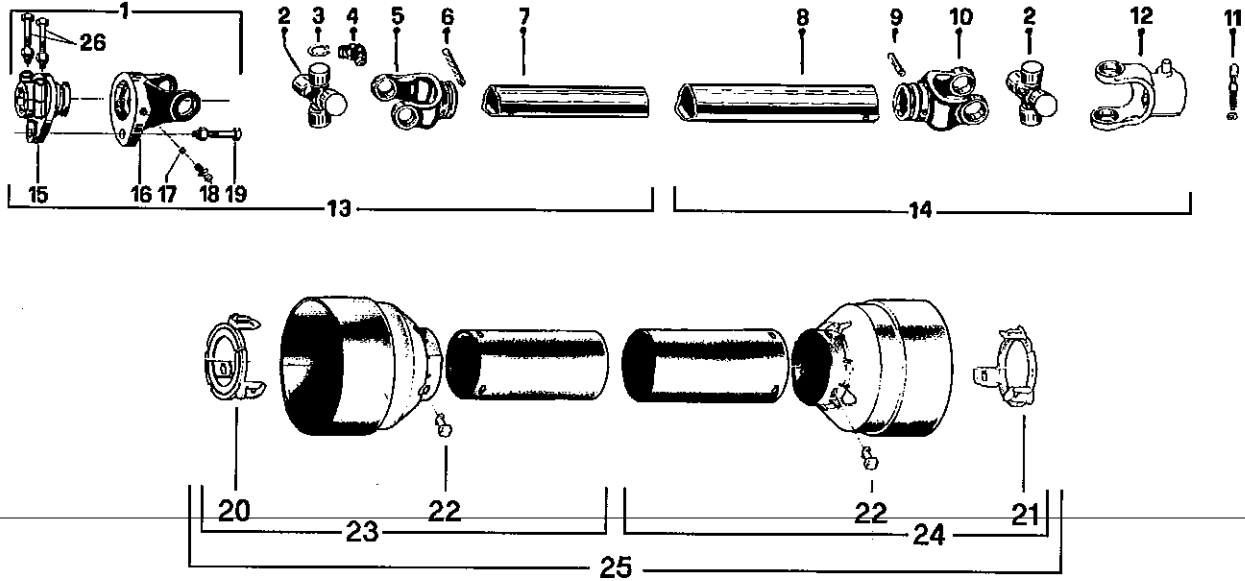

REF.	PART #	DESCRIPTION	QTY
1	8221	Safety shear yoke (2 bolts) .....	1
2	8073	U joint + 4 retaining rings + 1 grease fitting .....	2
3	8061	Retaining ring .....	8
4	8110	Grease fitting .....	2
5	8079	Yoke for inner tube .....	1
6	6341	Stopper for inner tube .....	1
7	8077	Inner tube .....	1
8	8076	Outer tube .....	1
9	8142	Stopper for outer tube .....	1
10	8074	Yoke for outer tube .....	1
11	8068	Yoke stopper 1 11/16" .....	1
12	8113	Yoke with hole 1 3/8"-6 splines + yoke stopper .....	1
13	8235	P.T.O. section, side with safety shear bolt, inner part, without protector .....	1
14	8236	P.T.O. section, side without safety shear bolt, outer part, without protector .....	1
15	8223	Adaptor (2 bolts) .....	1
16	8069	Yoke and shearplate .....	1
17	8070	Ball .....	17
18	8071	Grease fitting .....	1
19	8072	Safety shear bolt M10 x 50mm .....	1
20	8084-E	Bearing ring for inner guard tube .....	1
21	8083-E	Bearing ring for outer guard tube .....	1
22	8109	Stopper .....	6
23	8086	Inner shield .....	1
24	8085	Outer shield .....	1
25	8087	Complete shield .....	1
26	8222	Bolt M12 x 70mm + locknut .....	2

10

# GEAR BOX # 6451 (T281)

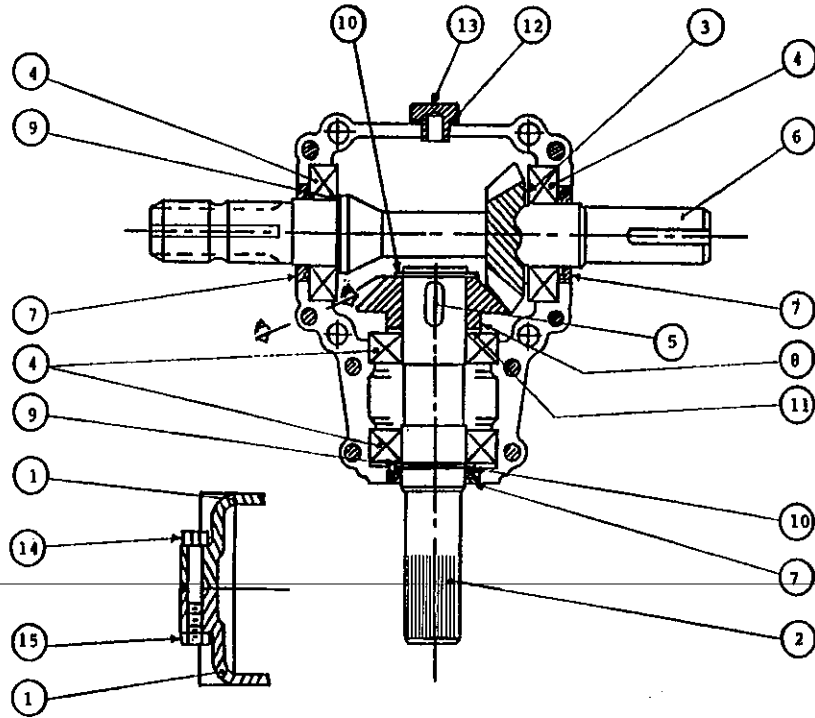

REF.	PART #	DESCRIPTION	QTY
1	6414	Casing .....	2
2	6429	Side shaft (1 1/4" - 19 splines) .....	1
3	6416	Spacer 35,3 x 48 .....	1
4	8056	Roller bearing no. 6207 .....	4
5	6418	Key 10 x 8 x 30 .....	1
6	6419	Impeller shaft (1 1/4" & 1 3/8" - 6 splines) .....	1
7	6420	Seal 35 x 52 x 7 .....	3
8	6421	Gear Z19 .....	1
9	6422	Spacer 35.3 x 0.5 .....	2
10	6423	Snap ring 35 UNI7435 .....	2
11	6424	Spacer 35.3 x 0.6 .....	1
12	6425	Oil seal .....	1
13	6426	Oil plug .....	1
14	6427	Bolt M8 x 55 .....	8
15	6428	Nut M8 .....	8

# GEAR BOX # 8251 (T27D)

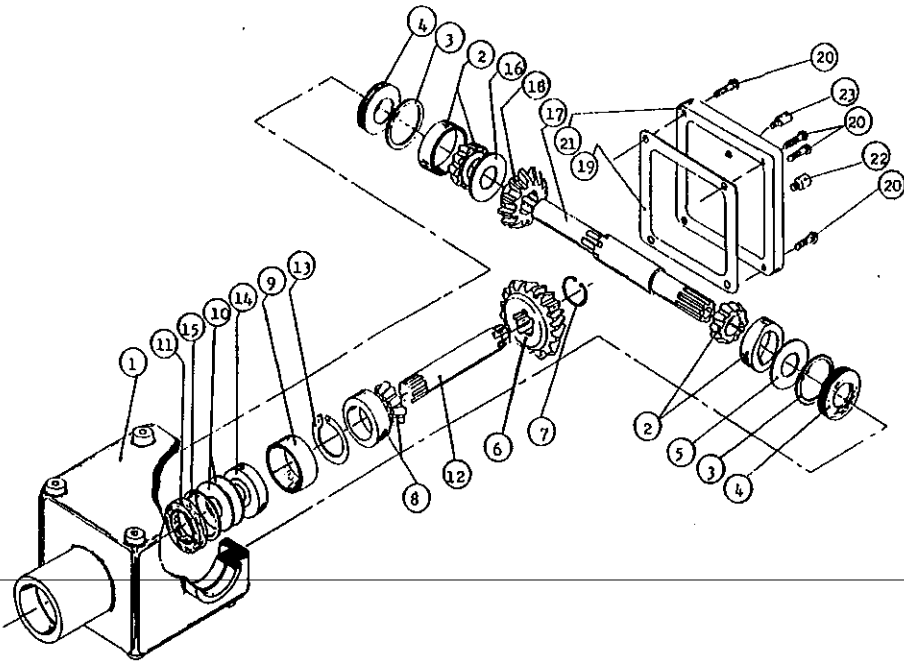

REF.	PART #	DESCRIPTION	QTY
1	8043	Casing .....	1
2	8044	Roller bearing no. 30208 .....	2
3	8045	Inside circlip 80mm .....	2
4	8046	Oil seal 40 x 80 x 12mm .....	2
5	8047	Adjusting washer .....	1
6	8048	Gear Z18 .....	1
7	8049	Outside circlip 40mm .....	1
8	8050	Roller bearing no. 30207 .....	1
9	8051	Spacer ring .....	1
10	8052	Adjusting washer .....	2
11	8053	Oil seal 35 x 72 x 12mm .....	1
12	8054	Side shaft (1 1/4" - 19 splines) .....	1
13	8055	Outside circlip 72mm .....	1
14	8056	Ball bearing no. 6207 .....	1
15	8057	Inside circlip 35mm .....	1
16	8058	Adjusting washer .....	1
17	8252	Impeller shaft (1.575" & 1 3/8" - 6 splines) .....	1
18	8060	Gear Z-18 .....	1
19	8061	Gasket .....	1
20	8062	Bolt M10 x 14mm .....	4
21	8063	Cover .....	1
22	8064	Oil plug .....	1
23	8065	Oil filler plug .....	1

10



# CYLINDER 25TR04

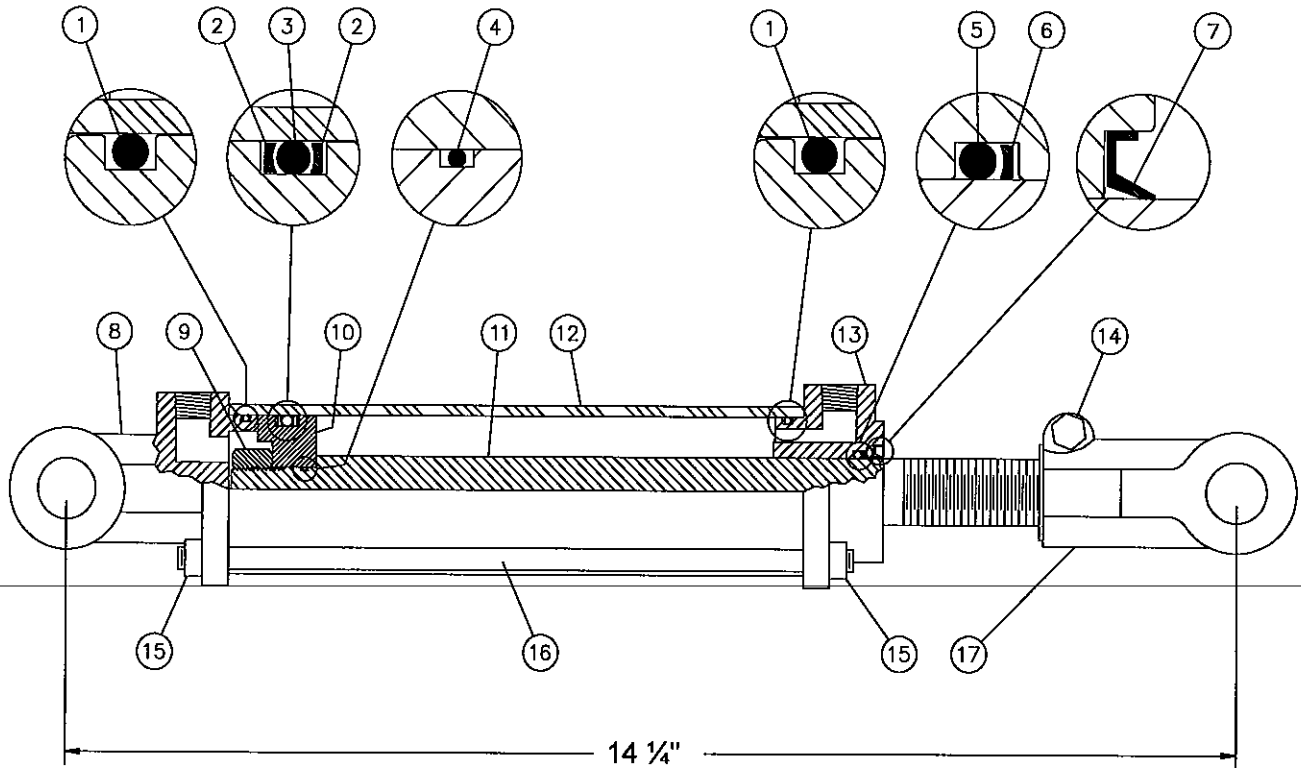

REF.	PART #	DESCRIPTION	QTY
1	See #RK25TR	O-ring 1/8" x 2 1/4" x 2 1/2" .....	2
2	See #RK25TR	Back-up 2 1/2" o.d. x 3/16" ø .....	2
3	See #RK25TR	O-ring 3/16" x 2 1/8" x 2 1/2" .....	1
4	See #RK25TR	O-ring 1/16" x 5/8" x 3/4" .....	1
5	See #RK25TR	O-ring 1/8" x 1 1/8" x 1 3/8" .....	1
6	See #RK25TR	Back-up 1 3/8" o.d. x 1/8" ø .....	1
7	See #RK25TR	Wiper 1 1/8" i.d. x 1 5/8" o.d. ....	1
8	492401	Yoke (for 2 1/2" tube) .....	1
9	Std.	Nut 3/4" NF .....	1
10	4924-31	Piston 2 1/2" ø .....	1
11	491980-04	Piston rod 1 1/8" .....	1
12	491668-04	Cylinder body 2 1/2" ø .....	1
13	492421	Head (for 2 1/2" tube) .....	1
14	Std.	Bolt 3/8" NC x 2 1/4" + nut .....	1
15	Std.	Nut 3/8" NC .....	8
16	Std.	Threaded rod 3/8" NC x 8" lg .....	4
17	458599	Yoke (for 1 1/8" rod) .....	1
NI*	8183	Pin 1" ø + cotter pin .....	2
NI*	RK25TR	Repair kit for cylinder 2 1/2" (includes # 1, 2, 3, 4, 5, 6, & 7) .....	1

\*NI = NOT ILLUSTRATED

# HYDRAULIC MOTOR DH 100, DH 125 & DH 250

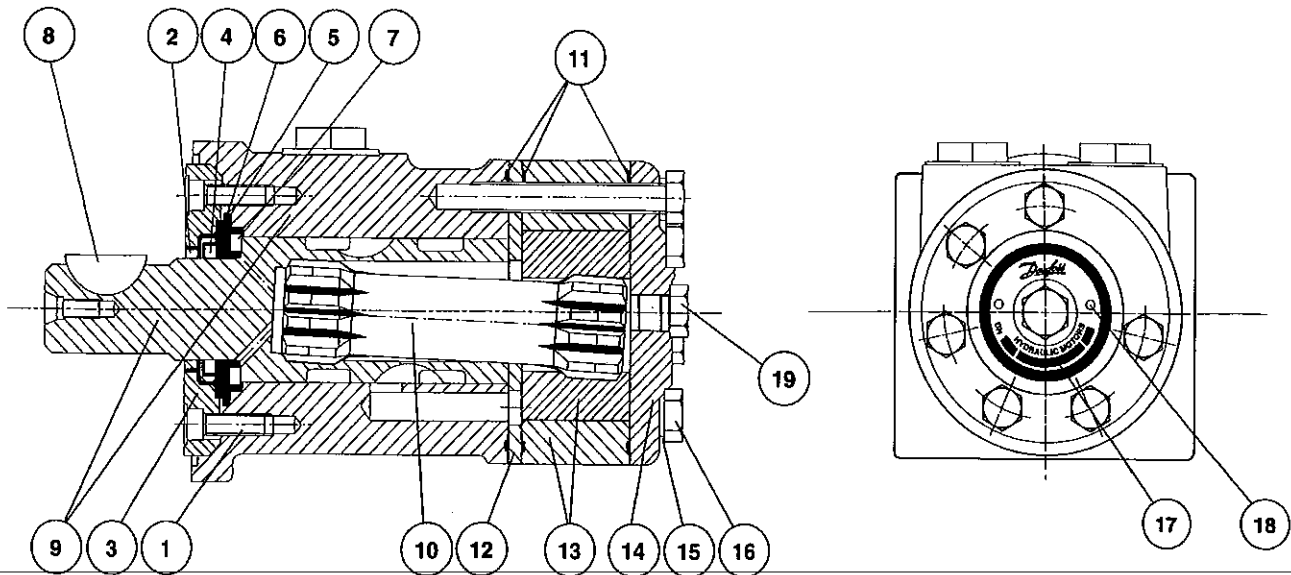







REF.	CODE #	DESCRIPTION	QTY		
			DH 100	DH 125	DH 250
1	681X1961	Screw M5 x 16mm .....	6	6	6
2	151-1313	Dust seal ring .....	1	1	1
3	151-1827	Spigot flange .....	1	1	1
4	633B3385	Shaft seal BAKDH ring .....	1	1	1
5	633B1333	O-ring .....	1	1	1
6	151-1608	Bearing race .....	1	1	1
7	151-1458	Axial needle bearing .....	1	1	1
8	682L9054	Woodruff key .....	1	1	1
9	-----	Housing and output shaft .....	not sold		
10	151-2645	Cardan shaft .....	1	-	-
10	151-2646	Cardan shaft .....	-	1	-
10	151-2649	Cardan shaft .....	-	-	1
11	633B1173	O-ring .....	3	3	3
12	151-1713	Distributor plate .....	1	1	1
13	151-1128	Gear wheel set .....	1	-	-
13	151-1112	Gear wheel set .....	-	1	-
13	151-1193	Gear wheel set .....	-	-	1
14	151-2641	End cover .....	1	1	1
15	684X2481	Washer .....	6	6	6
16	681X0180	Screw M8 x 1.25mm Din 931 x 40mm lg .....	6	-	-
16	681X0181	Screw M8 x 1.25mm Din 931 x 45mm lg .....	-	6	-
16	681X0184	Screw M8 x 1.25mm Din 931 x 60mm lg .....	-	-	6
17	151A0415	Name plate .....	1	1	1
18	681Z1011	Drive screw .....	2	2	2
19	631X2013	Drain plug 7/16"-20 UNF .....	1	1	1
NI*	151-1273	Set of seals .....	1	1	1





\*NI = NOT ILLUSTRATED

# TORQUE CHART

## TORQUE SPECIFICATION TABLE

Thread UNC and UNF		Grade 2 				Grade 5   				Grade 8*   			
Bolt size		Torque				Torque				Torque			
Inches	mm	Pound feet min.	Pound feet max.	Newton meters min.	Newton meters max.	Pound feet min.	Pound feet max.	Newton meters min.	Newton meters max.	Pound feet min.	Pound feet max.	Newton meters min.	Newton meters max.
1/4	6.35	5	6	6.8	8.13	9	11	12.2	14.9	12	15	16.3	30.3
5/16	7.94	10	12	13.6	16.3	17	20.5	23.1	27.8	24	29	32.5	39.3
3/8	9.53	20	23	27.1	31.2	35	42	47.5	57.0	45	54	61.0	73.2
7/16	11.11	30	35	40.7	47.4	54	64	73.2	86.8	70	84	94.9	113.9
1/2	12.70	45	52	61.0	70.5	80	96	108.5	130.2	110	132	149.2	179.0
9/16	14.29	65	75	88.1	101.6	110	132	149.2	179.0	160	192	217.0	260.4
5/8	15.88	95	105	128.7	142.3	150	180	203.4	244.1	220	264	298.3	358.0
3/4	19.05	150	185	203.3	250.7	270	324	366.1	439.3	380	456	515.3	618.3
7/8	22.23	160	200	216.8	271.0	400	480	542.4	650.9	600	720	813.6	976.3
1	25.40	250	300	338.8	406.5	580	696	786.5	943.8	900	1080	1220.4	1464.5
1 1/8	25.58	-	-	-	-	800	880	1084.8	1193.3	1280	1440	1735.7	1952.6
1 1/4	31.75	-	-	-	-	1120	1240	1518.7	1681.4	1820	2000	2467.9	2712.0
1 3/8	34.93	-	-	-	-	1460	1680	1979.8	2278.1	2380	2720	3227.3	3688.3
1 1/2	38.10	-	-	-	-	1940	2200	2630.6	2983.2	3160	3560	4285.0	4827.4

\* Thick nuts must be used with grade 8 bolts.

Size of screw	Thread	Pitch (mm)	Grade 4T  				Grade 7T 				Grade 8T  			
			Torque				Torque				Torque			
			Pound feet min.	Pound feet max.	Newton meters min.	Newton meters max.	Pound feet min.	Pound feet max.	Newton meters min.	Newton meters max.	Pound feet min.	Pound feet max.	Newton meters min.	Newton meters max.
M6	UNC	1.00	3.6	5.8	4.9	7.9	5.8	9.4	7.9	12.7	7.2	10	9.8	13.6
M8	UNC	1.25	7.2	14	9.8	19	17	22	23	29.8	20	26	27.1	35.2
M10	UNC	1.5	20	25	27.1	33.9	34	40	46.1	54.2	38	46	51.5	62.3
M12	UNC	1.75	28	34	37.9	46.1	51	59	69.1	79.9	57	66	77.2	89.4
M14	UNC	2.0	49	56	66.4	75.9	81	93	109.8	126	96	109	130.1	147.7
M16	UNC	2.0	67	77	90.8	104.3	116	130	157.2	176.2	129	145	174.8	196.5
M18	UNC	2.0	88	100	119.2	136	150	168	203.3	227.6	175	194	237.1	262.9
M20	UNC	2.5	108	130	146.3	176.2	186	205	252	277.8	213	249	288.6	337.4
M8	UNF	1.0	12	17	16.3	23	19	27	25.7	36.6	22	31	29.8	42
M10	UNF	1.25	20	29	27.1	39.3	35	47	47.4	63.7	40	52	54.2	70.5
M12	UNF	1.25	31	41	42	55.6	56	68	75.9	92.1	62	75	84	101.6
M14	UNF	1.5	52	64	70.5	86.7	90	106	122	143.6	107	124	145	168
M16	UNF	1.5	69	83	93.5	112.5	120	138	162.6	187	140	158	189.7	214.1
M18	UNF	1.5	100	117	136	158.5	177	199	239.8	269.6	202	231	273.7	313
M20	UNF	1.5	132	150	178.9	203.3	206	242	279.1	327.9	246	289	333.3	391.6

Use the above torques when special torque is not given.

NOTE: These values apply to fasteners as received from supplier, dry, or when lubricated with normal engine oil. They do not apply if extreme pressure lubricants are used.

---

---

## WARRANTY

---

12

PRONOVOST warrants this product to the initial purchaser for the period of one year from the date of purchase against defects in materials and workmanship.

We will replace or repair defective parts free of charge if they are returned to our plant in St-Tite, Quebec, Canada.

Transportation charges are the responsibility of the customer. This warranty is not transferable.

Hydraulic cylinders and motors are covered by the manufacturer of these items.

All PRONOVOST spare parts purchased are covered by a three (3) month warranty.

This warranty becomes void and nul if the equipment is modified, breaks down as the result of an accident, is not operated according to manufacturer's recommendations, damaged by negligence or if maintenance has not been carried out as specified.

Our obligation is limited to the replacement or repair of the defective part. PRONOVOST accepts no responsibility for direct or indirect consequential damages of any kind.

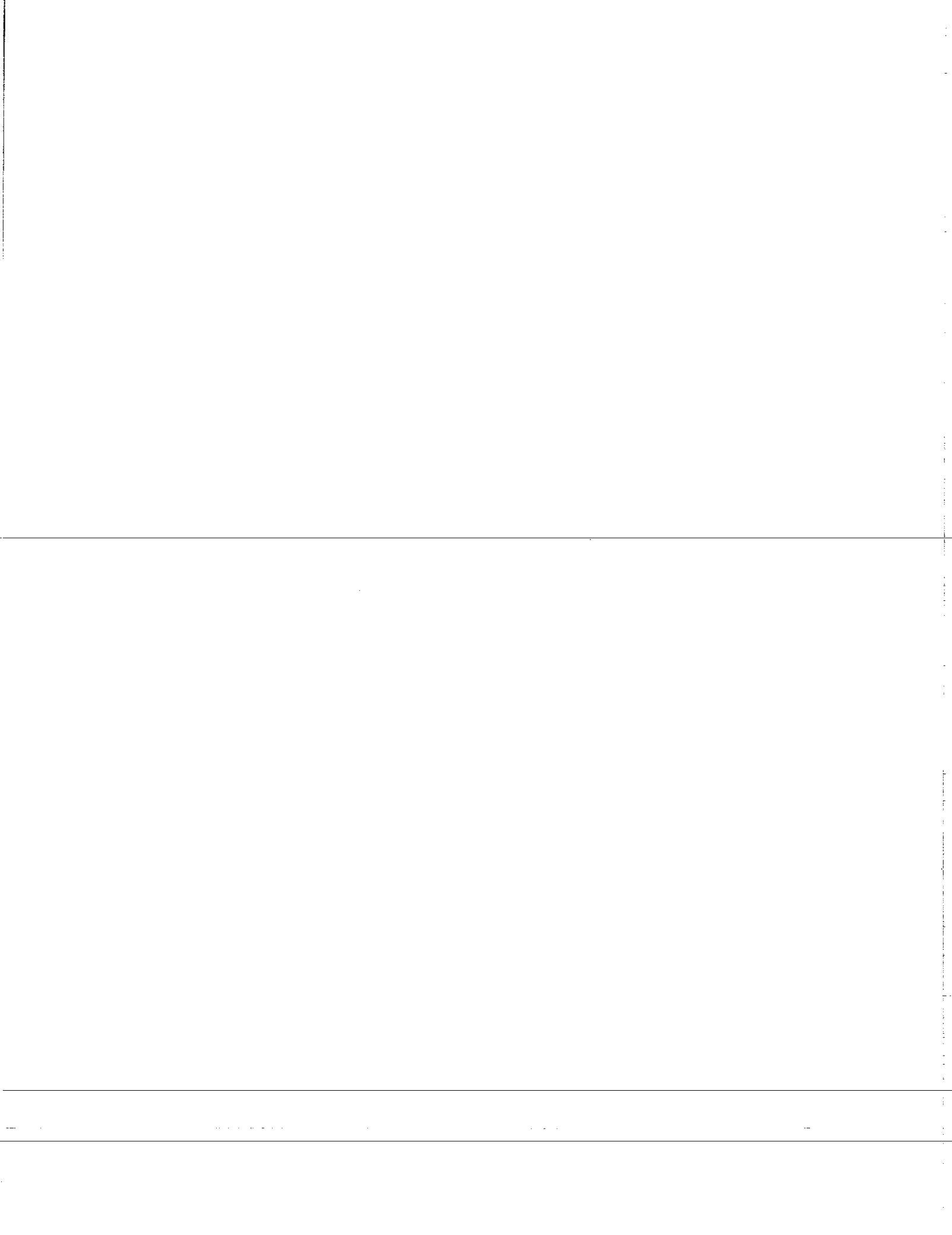

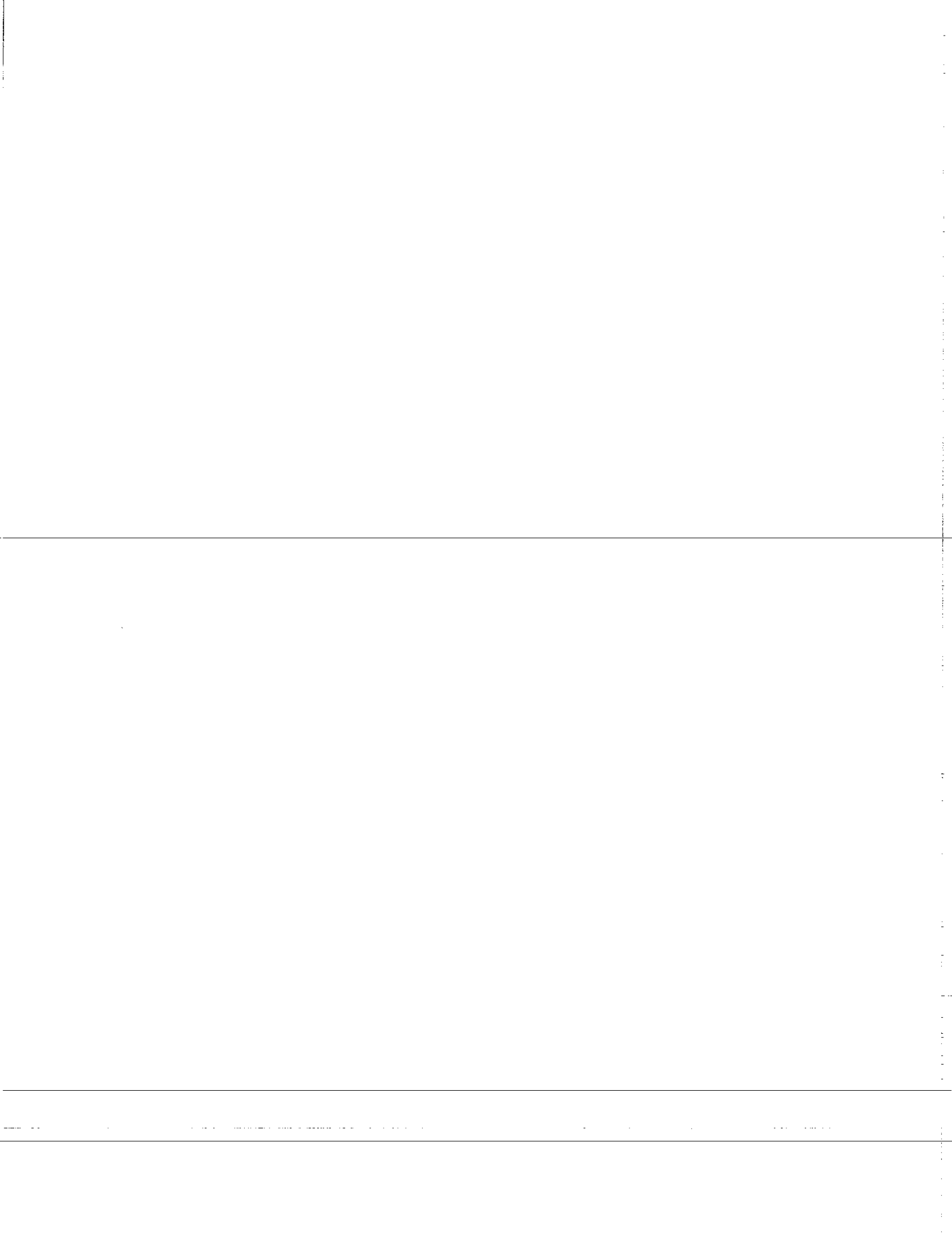

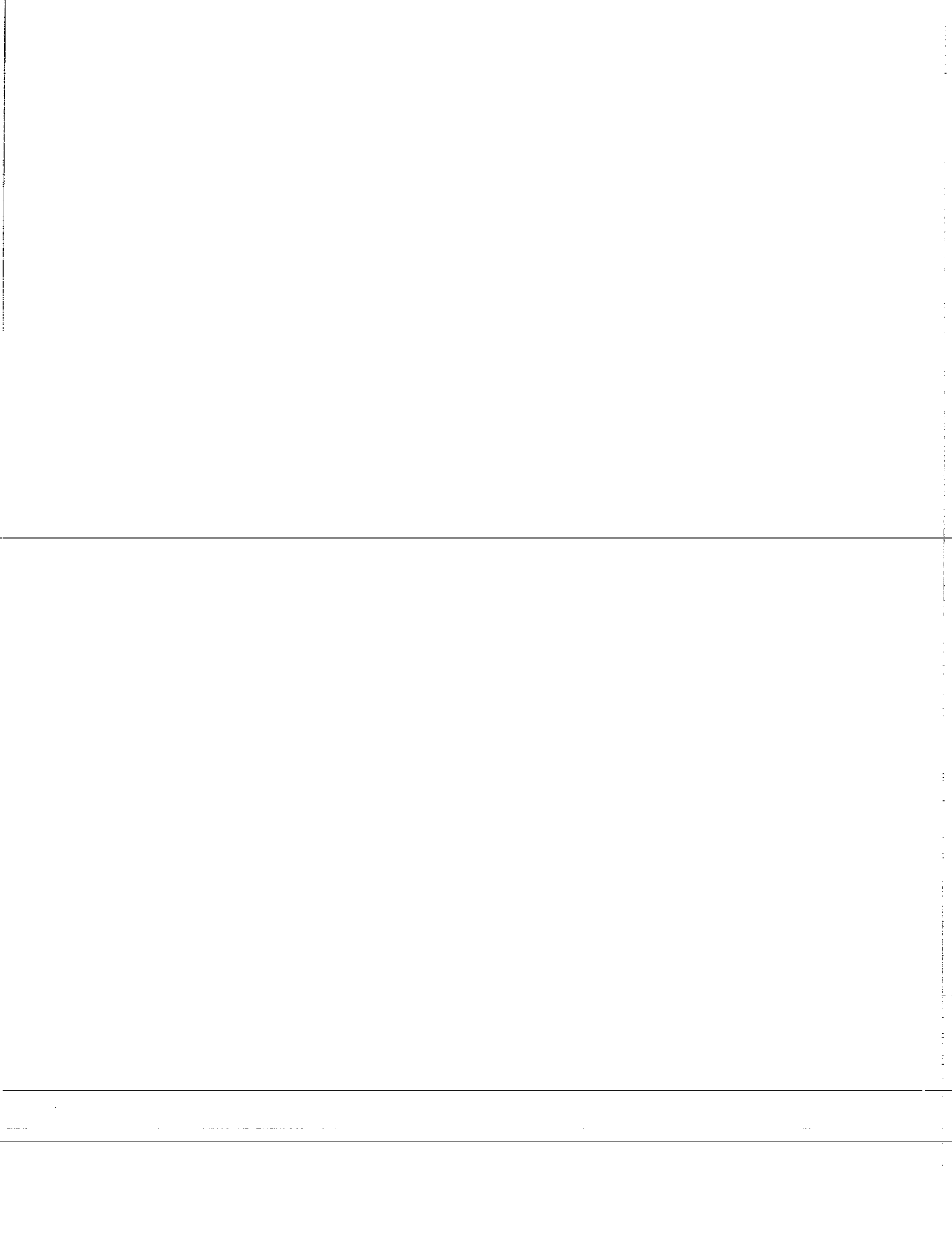

---

Ce manuel est aussi disponible en français.  
Veuillez téléphoner.



---

**LES MACHINERIES PRONOVOST INC.**  
260, route 159,  
Saint-Tite, Quebec, Canada, G0X 3H0  
Tel.: (418) 365-7551, Fax: (418) 365-7954

---