

PRONOVOST

OWNER'S MANUAL

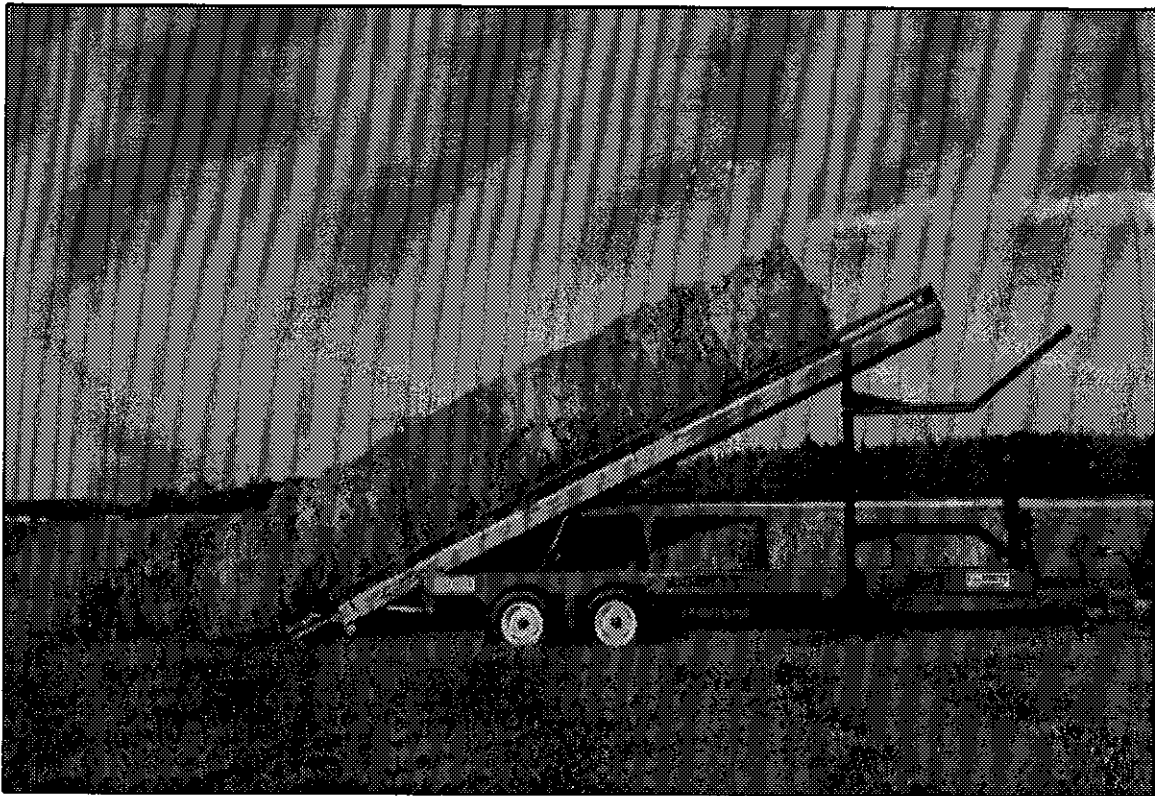

Auto-Load Round Bale Handler

Models

P-6807 P-6808 P-6812 P-6816

Copyright © Les Machineries Pronovost Inc., 1995

All rights reserved.
Printed in Canada.

TABLE OF CONTENTS

Section	Item	Page
1	Introduction	5
2	Safety	6
	General Safety	6
	Safety in Operation	6
	Safety with Maintenance	6
	Safety in Transport	6
	Safety in Storage	6
3	Decals	7
	Safety Decals	7
	Maintenance Decals	8
4	Start-up	9
	Basic Start-up Procedures	9
	Adjustments	10
	Operation	11
5	Maintenance	13
6	Storage	14
7	Specifications	15
8	Parts List	16
	Electric system Auto-Load Round Bale Handler (All models)	16
	Hydraulic system Auto-Load Round Bale Handler P-6807	18
	Hydraulic system Auto-Load Round Bale Handler P-6808	20
	Hydraulic system Auto-Load Round Bale Handler P-6812	22
	Hydraulic system Auto-Load Round Bale Handler P-6816	24
	Cylinder 30AS20	26
	Cylinder 35BS24	27
	Cylinder 30F84	28
	Telescopic cylinder 110-00471	29
	Hubs H5000 H8000 H10000	30
9	Torque Chart	31
10	Warranty	32



INTRODUCTION

1

CONGRATULATIONS!

Thank you for choosing PRONOVOST. We are confident this equipment will meet your requirements in terms of quality, performance and reliability.

This manual was prepared to assist you in the safe operation of your new Auto-Load Round Bale Handler. It contains important information which will help you achieve excellent returns with your round bale handler for years to come.

Please read this manual completely before operating this equipment and keep it for future reference.

Before using the equipment, you or any other person who will be operating the Round Bale Handler must be familiarized with the safety recommendations. Please read carefully and be sure to understand and follow all recommendations and procedures.

In this manual, the right and left sides of the equipment are identified while standing behind the machine and facing it.

If you require additional information on your Round Bale Handler, please contact your PRONOVOST Dealer.

NOW take a moment to enter the model, serial number and the date of purchase of your Auto-Load Round Bale Handler in the space provided.

When ordering parts from your Dealer, please refer to these numbers for a fast and efficient service. Use PRONOVOST replacement parts.

The model and serial numbers are on the nameplate shown on Figure 1.

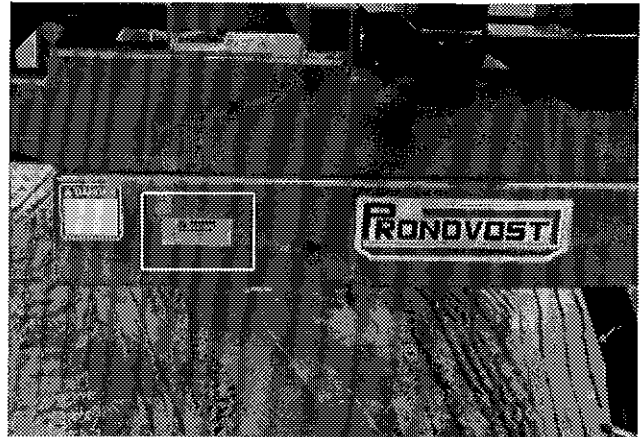

Figure 1

MODEL: _____

SERIAL NO.: _____

DATE OF PURCHASE: _____

SAFETY

GENERAL SAFETY

WHEN YOU SEE THIS SYMBOL

2



ATTENTION!

**BE ALERT
YOUR SAFETY IS INVOLVED**

This symbol "SAFETY ALERT" is used in this manual and on the safety decals on the Round Bale Handler. It warns you of the possibility of danger. Carefully read, understand and follow all safety recommendations before operating the unit.

- 1) Careful operation is the best assurance against accidents. Carefully read this manual and follow all recommendations before operating your Round Bale Handler. It is the owner's responsibility to make sure that anyone who will operate the unit will read this manual before operating the equipment.
- 2) Never let a child nor unauthorized persons operate the machine.
- 3) Do not modify the equipment. Any non authorized modification may affect the efficiency and/or safety of the equipment.
- 4) Never operate the Round Bale Handler with defective parts or if damaged in any way. Have it repaired before operating.
- 5) Make sure all fasteners are in place and properly secured or tightened. Refer to torque chart on page 31.
- 6) Hydraulic fluids under pressure can damage your skin. Do not use your hands to locate a leak. Gloves must be worn.

SAFETY IN OPERATION

- 1) Be sure there are no obstructions around the equipment and that no one stands near the machine when in operation or unloading.
- 2) Be careful when adjusting equipment with engine running.
- 3) Keep your body, hands, feet, hair and clothing away from moving parts.
- 4) Do not stand nor allow anyone to stand under elevated parts of the machine.
- 5) When not in use, always lock the loading arms with the pin provided. (Figure 10, page 9)

SAFETY WITH MAINTENANCE

- 1) Perform maintenance according to the recommendations contained in this manual.
- 2) Stop engine and relieve all hydraulic pressures before doing inspection, maintenance or repairs.
- 3) Regularly check hydraulic lines and fittings for leaks. Replace if necessary.
- 4) If you must perform work under the raised platform, **always block it in position in a safe manner.**

SAFETY IN TRANSPORT

- 1) Check local regulations for the transport of your Round Bale Handler on the road.
- 2) Be alert when pulling the Round Bale Handler on the road. Do not allow anyone to stand on it while in motion.
- 3) Be careful while backing-up.

SAFETY IN STORAGE

- 1) Lock the loading arms with the pin provided. (Figure 10, page 9)

DECALS

SAFETY DECALS

The safety decals are affixed wherever special safety precautions are indicated. Locate them on the machine and read them carefully. If a decal is damaged, lost or illegible, install a new one. Each decal is identified with a letter and part number. The following photos indicate where each one must be installed.

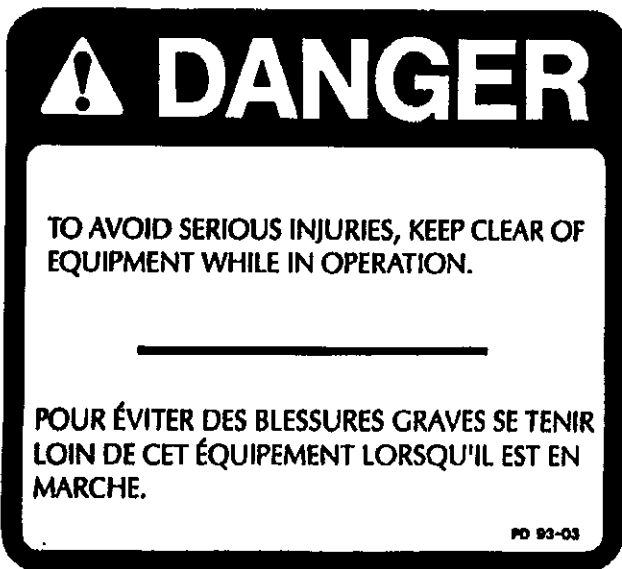

Figure 2
Decal A

Part no.: A101

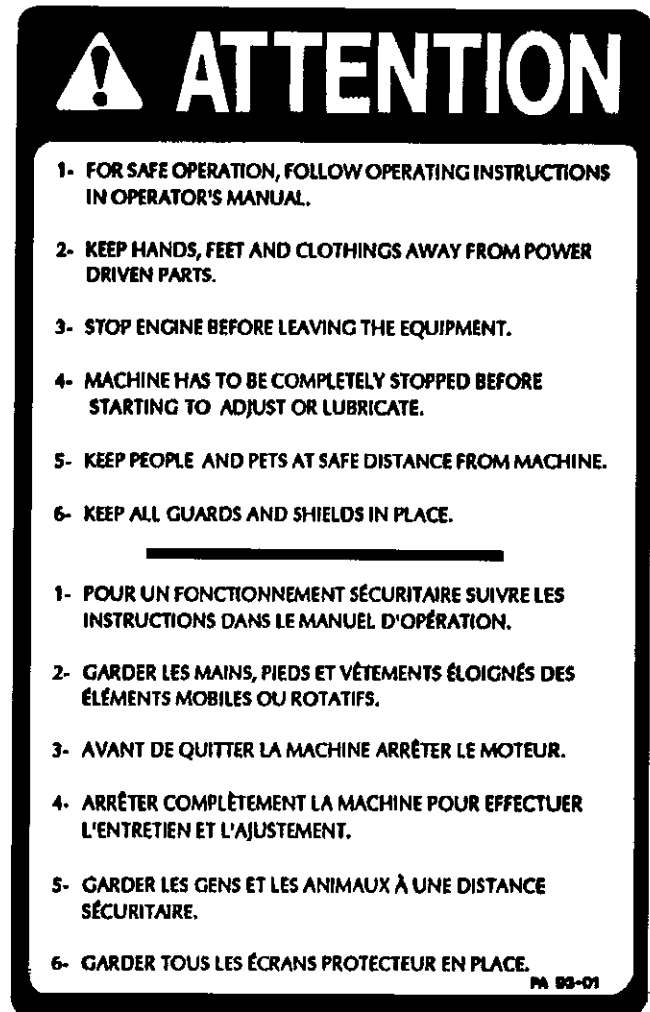

Figure 4
Decal B

Part no.: A102

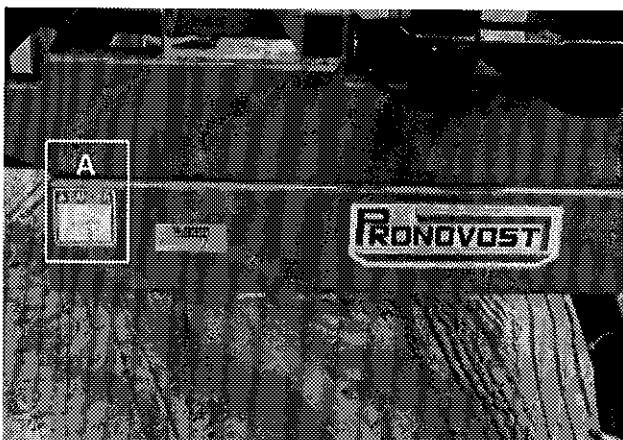

Figure 3

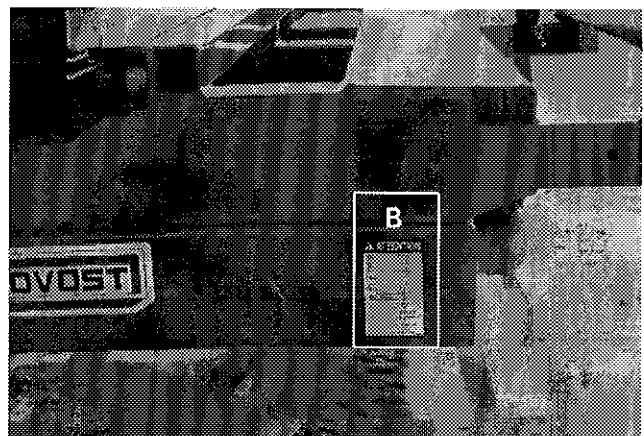

Figure 5

DECALS (cont'd)

///▲ DANGER ///

Figure 6
Decal C

Part no.: A103

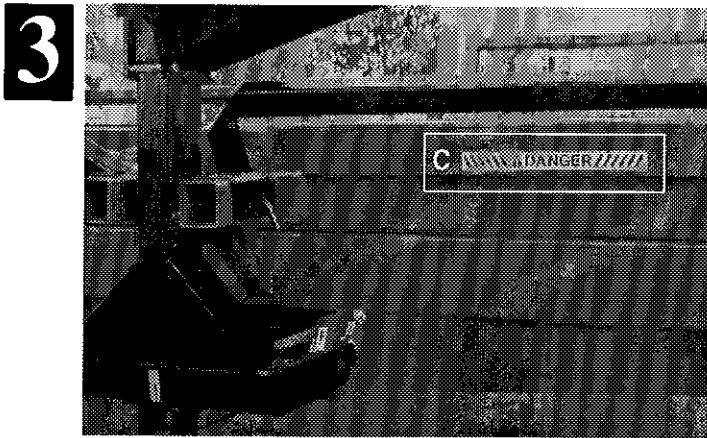
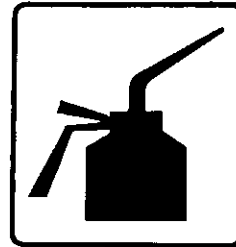

Figure 7

MAINTENANCE DECALS

The maintenance decals indicate the points requiring lubrication. Refer to the maintenance section for more details.



Part no.: A105



Part no.: A106

Figure 8

START-UP

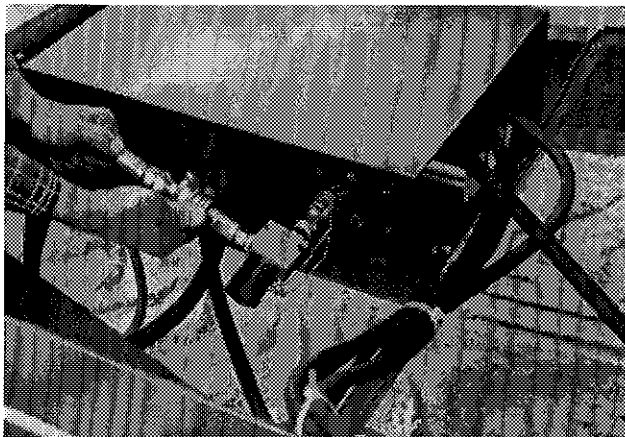

Figure 9

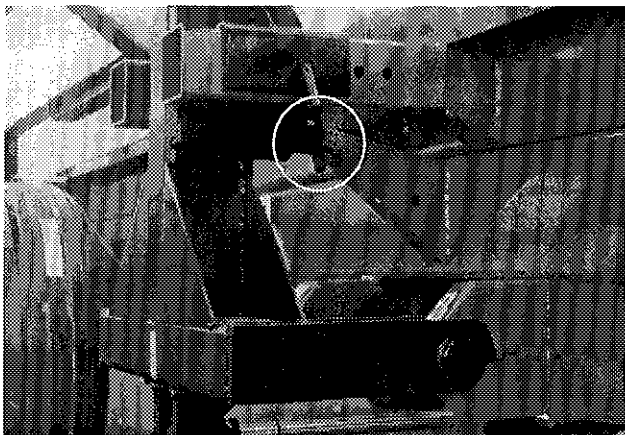

Figure 10

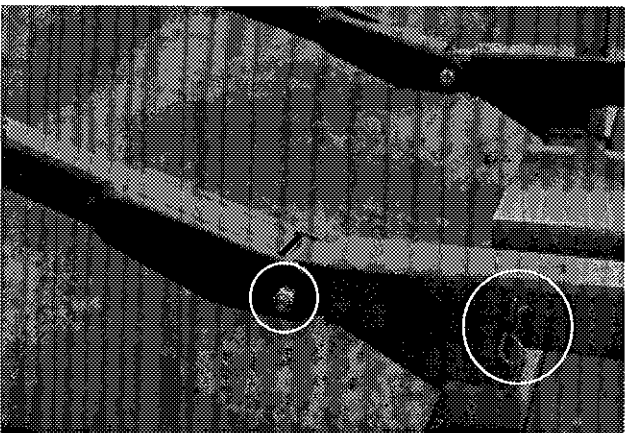

Figure 11

BASIC START-UP PROCEDURES

- 1) Lubricate all points with a good quality multi use grease.
- 2) Adjust tire pressure according to manufacturer's recommendation.
- 3) Install all hydraulic hoses and fittings compatible with your equipment.
- 4) If your tractor is equipped with a close center hydraulic system, the conversion kit P-6890 must be installed. A plug-in solenoid valve is provided as an option and must be connected to the hydraulic circuit and to the electric circuit. (Figure 9).

4

Models P-6812 & P-6816 only.

- 5) A third hydraulic line is required to return the oil directly to the hydraulic reservoir of the tractor.
- 6) Hook up the Round Bale Handler to the tractor and connect the hydraulic hoses as indicated in page 18, 20, 22 or 24.
- 7) Install the control module in a convenient location near the tractor seat, usually on the right hand side.
- 8) Operate all hydraulic functions in order to purge the system. **Do not forget to remove the pin locking the loading arm in the upright position (Figure 10) and assure there is no one within 10 feet of the loading area.**
- 9) Check the oil level in the tractor's hydraulic oil reservoir.
- 10) Install rear bale supports, 2 or 4 depending on equipment model. Install the bolts and pins with nut and hair pin on the support arms to prevent catching of the bale twine. (Figure 11)
- 11) Although it is possible to transport an additional bale in the loading arm, **its weight must not exceed 1000 lbs.**

START-UP (cont'd)

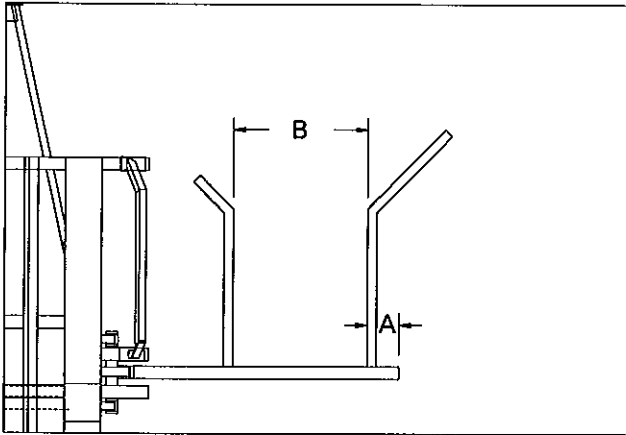

4 Figure 12



Figure 13

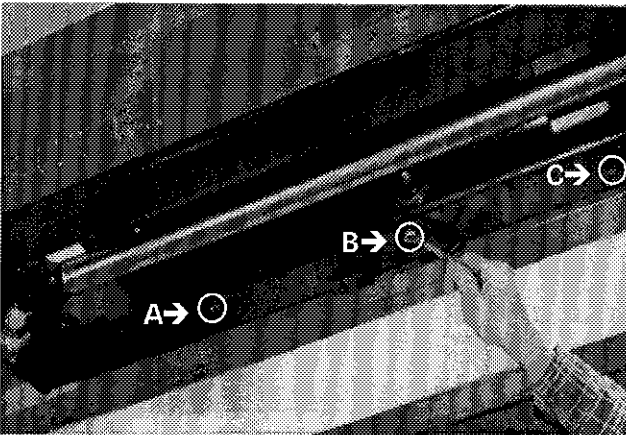

Figure 14

ADJUSTMENTS

LOADING ARMS (Patented)

- 1) Adjust the opening and position of the loading arms according to recommendations (Figure 12). Adjust length A to 14" and length B to (Bale diameter less 8" to 10"). The dimensions given are to be used as a guide only since they may vary according to the bale size, weight and degree of softness.

Models P-6808, P-6812 & P-6816 only.

SIDE RAILS

- 1) Adjust the side rails position according to the bale size and configuration (Figure 13). This adjustment is to prevent the rocking of the bales from side to side during transportation.

BALE RAM

- 1) The length of stroke is factory set for the longest bale dimension (5 1/2') (holes A & B) although the stroke can be shortened to further increase the efficiency of the machine while handling shorter bales (4') (holes B & C) (Figure 14).

SWIVEL HITCH ASSEMBLY

- 1) Adjust the swivel hitch assembly to keep the machine parallel with the ground. Two sets of bolt holes are provided (Figure 15) to keep the machine level in operation.

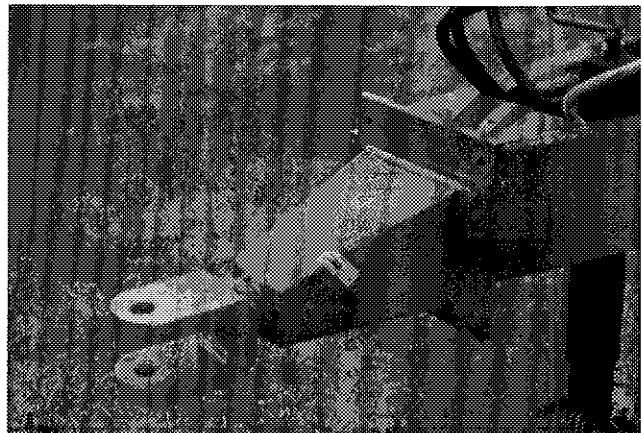

Figure 15

START-UP (cont'd)

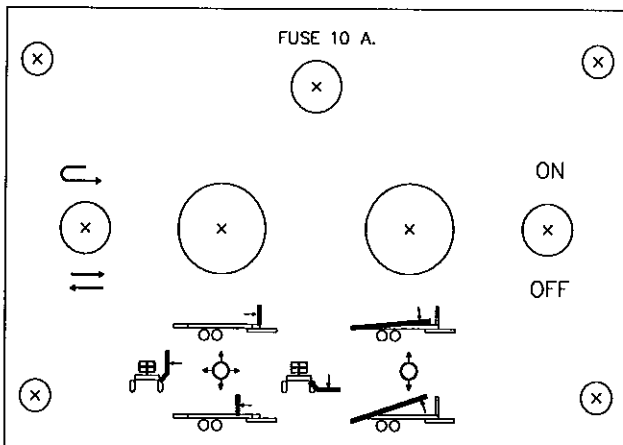

Figure 16

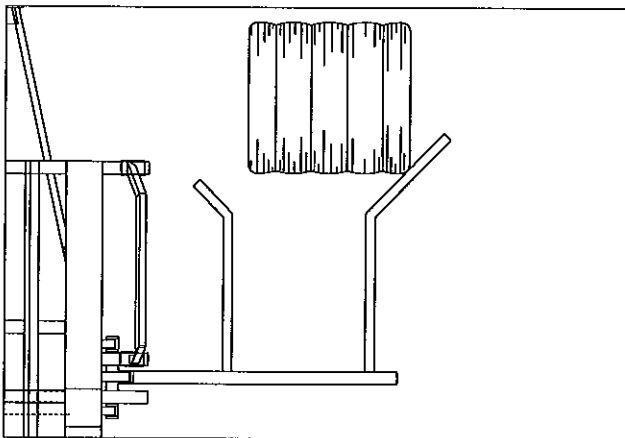

Figure 17

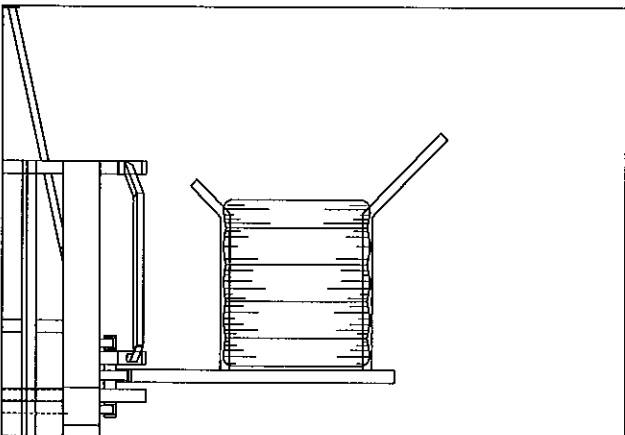

Figure 18

OPERATION

- 1) First familiarize yourself with the controls and their functions. (Figure 16)
- 2) Remember that the Round Bale Handler is designed and built to turn the bales and load them non stop, consequently, the direction of travel will usually be the same as the baler's.
- 3) When ready for the first bale, lower the loading arm to just a few inches above the ground, slow down this is a practice round, line up the machine so that the outer corner of the bale will touch at approximately 1/3 to 1/2 way up the angled part of the outer arm. (Figure 17)

4

- 4) Raise the loading arm as soon or slightly before the bale reaches the bottom of the "U". (Figure 18)

Model P-6807 only.

- 5) Keep raising the bale until it drops onto the platform then start lowering the loading arm and momentarily actuate the ram control lever (ram switch in the "AUTO" position). The ram will index the bale toward the rear and automatically will return to the front position. By then, you should be approaching the next bale and be ready to repeat the procedure.

Models P-6808, P-6812 & P-6816 only.

- 6) The same procedure as 5 above except that since you are loading in two rows, you must wait until two (2) bales are on the platform before actuating the ram control lever. On those models there is a limit switch installed on the machine, so the ram pusher and the dumping platform can't be activated if the loading arm isn't lowering enough.
- 7) Once accustomed to the machine and its operation, you will notice that by slightly altering the alignment of the bale relative to the outside loading arm, you will be able to turn it and load it much more rapidly. In this case, the bale should hit the loading arm slightly closer to the heel.

START-UP (cont'd)

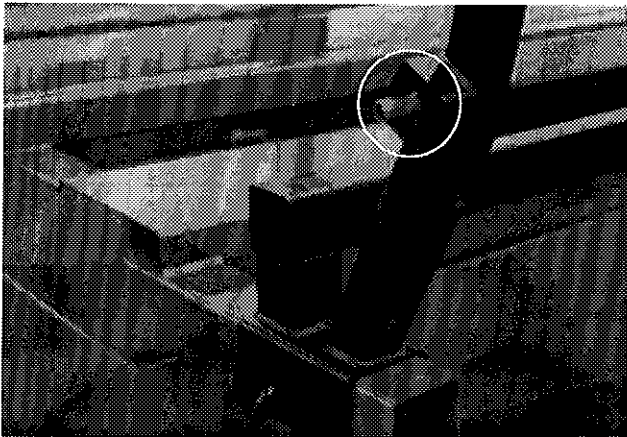

4

Figure 19



Figure 20



Figure 21

Models P-6812 & P-6816 only.

8) When the first pair of bales loaded reach the bale supports at the extreme rear end of the platform, an indicator will pop up on the front corner of the platform opposite from the loading arm. (Figure 19)

9) To unload the bales, simply back up to the area where you wish to deposit the bales, open up the loading arm slightly to clear the platform. Raise the platform fully, then slowly move forward.

Model P-6808 only.

10) The P-6808 model permits to unload 2 stacks of 3 bales high vertically (Fig. 20), by using the vertical forks at rear (Fig. 21) included with the machine. Therefore, the loading capacity is limited to 6 bales (4' long bales).

11) To unload in rows on the ground, the rear bale support must be used, which permits maximum capacity load of 8 bales. A maximum angle indicator is installed on the machine. When the yellow pin appears, the ideal unload angle is reached (Fig.22).

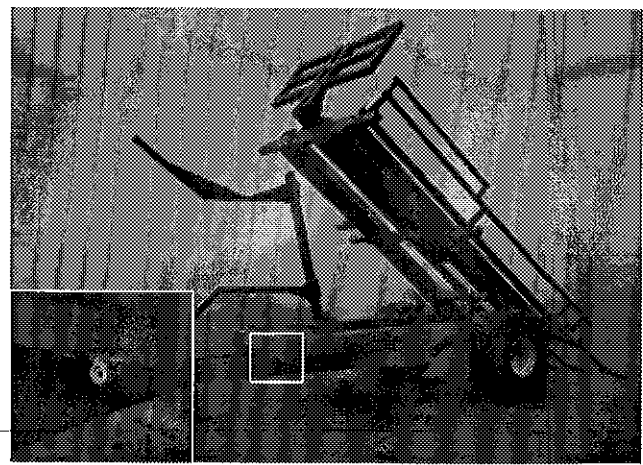

Figure 22

MAINTENANCE

The Auto-Load Round Bale Handler is designed to save you energy, time and money, take care of it, protect your investment.

- 1) Wipe off all grease fittings with a clean cloth before adding grease to avoid injecting contaminants.
- 2) Repair or replace damaged grease fittings.
- 3) Lubricate all grease fittings every 20 hours of operation. (Do not forget the Bale Ram, 4 bronze bushings).
- 4) Open, clean and lubricate wheel bearings once a year.
- 5) Check nuts and bolts once a year. If necessary, use torque chart page 31.
- 6) Check all bolts on wheels after the first 5 hours of operation and then every 50 hours.
- 7) Check tire pressure every 50 hours. Adjust according to manufacturer's recommendations indicated on the tires.
- 8) Keep your equipment clean, it is good practice.

5

STORAGE

- 1) Store the Auto-Load Round Bale Handler in a cool, dry place.
- 2) Keep tires off the ground and cover them if left exposed to the sun.
- 3) Keep all piston rod in the retracted position. This will assure better protection against the elements.
- 4) Clean your Auto-Load Round Bale Handler.
- 5) Thoroughly inspect all parts of the Round Bale Handler. Replace or repair worn or defective parts.
- 6) Touch-up or repaint if necessary.
- 7) Lubricate all points before storage.

SPECIFICATIONS

MODELS		P-6807	P-6808	P-6812	P-6816
Capacity (tons)		7	8	12	16
Diam. of bales		4' to 6'	4' to 5 1/2' (6' opt.)	4' to 5 1/2' (6' opt.)	4' to 5 1/2' (6' opt.)
Length of bales		4' to 5 1/2'	4' to 5 1/2'	4' to 5 1/2'	4' to 5 1/2'
Sides adjustable to bales ø		---	Std.	Std.	Std.
4' b a l e s	Number of bales	7	6 vertical - 8 horizontal	12	16
	Vertical unloading	---	2 stacks of 3 bales	---	---
	Horizontal unloading	1 row of 7 bales	2 parallel rows of 4 bales	2 parallel rows of 6 bales	2 parallel rows of 8 bales
5' b a l e s	Number of bales	6	4 vertical - 6 horizontal	10	14
	Vertical unloading	---	2 stacks of 2 bales	---	---
	Horizontal unloading	1 row of 6 bales	2 parallel rows of 3 bales	2 parallel rows of 5 bales	2 parallel rows of 7 bales
Overall length		35' 9"	24' 9"	31' 7"	39' 7"
Overall width		7' 8"	8' 6" to 10' 0"	8' 6" to 10' 0"	8' 6" to 10' 0"
Platform height		36"	44"	44"	44"
Dumping angle		35 degrees	35 deg. and 90 deg.	35 degrees	35 degrees
Tread width (c/c)		79½"	81½"	85"	81½"
Hitch weight (empty)		1110 lbs. approx.	1500 lbs. approx.	1800 lbs. approx.	2800 lbs. approx.
Swivel hitch		Std.	Std.	Std.	Std.
Automatic return of bale ram		Std.	Std.	Std.	Std.
Remote control		Std.	Std.	Std.	Std.
Axle		Tandem	Simple	Tandem	Tandem
Hub (capacity)		5000 lbs.	10000 lbs.	8000 lbs.	10000 lbs.
Spindles (diameter)		2"	3"	2 3/4"	3"
Wheels (dimensions)		15 x 10	W16C16.1	W14C16.1	W16C16.1
Wheels (number of bolts)		6 bolts	8 bolts	8 bolts	8 bolts
Tires standard		12.5L15 10 ply	21.5L16.1 10 ply	16.5L16.1 10 ply	21.5L16.1 10 ply
Tractor required		60 to 75 HP	65 to 80 HP	80 to 100 HP	100 to 150 HP
Total weight		4200 lbs approx.	5700 lbs approx.	6800 lbs approx.	8100 lbs approx.

Design and specifications subject to change without notice.

7

ELECTRIC SYSTEM (cont'd)

REF.	PART #	DESCRIPTION	QTY
1	36100	Switch on-off	2
2	36101	Control lever 4 ways	1
3	18005	Fuse holder 10A	1
4	36102	Control box	1
5	36103	Harness	1
6	36104	Harness	1
7	36105	Harness	1
8	18009	Charger clip (red)	1
9	18010	Charger clip (black)	1
10	36106	Relay box	1
11	36107	4 connector relay	9
12	36108	5 connector relay	1
13	36109	Single way diode	8
14	36110	Harness	1
15	18017	Limit switch	3
16	36111	Harness	1
17	36112	Two way valve (closed circuit)	opt.
18	18019	Solenoid valve	3
19	18019	Solenoid valve	opt.
20	36113	Control lever 2 ways	1

HYDRAULIC SYSTEM P-6807

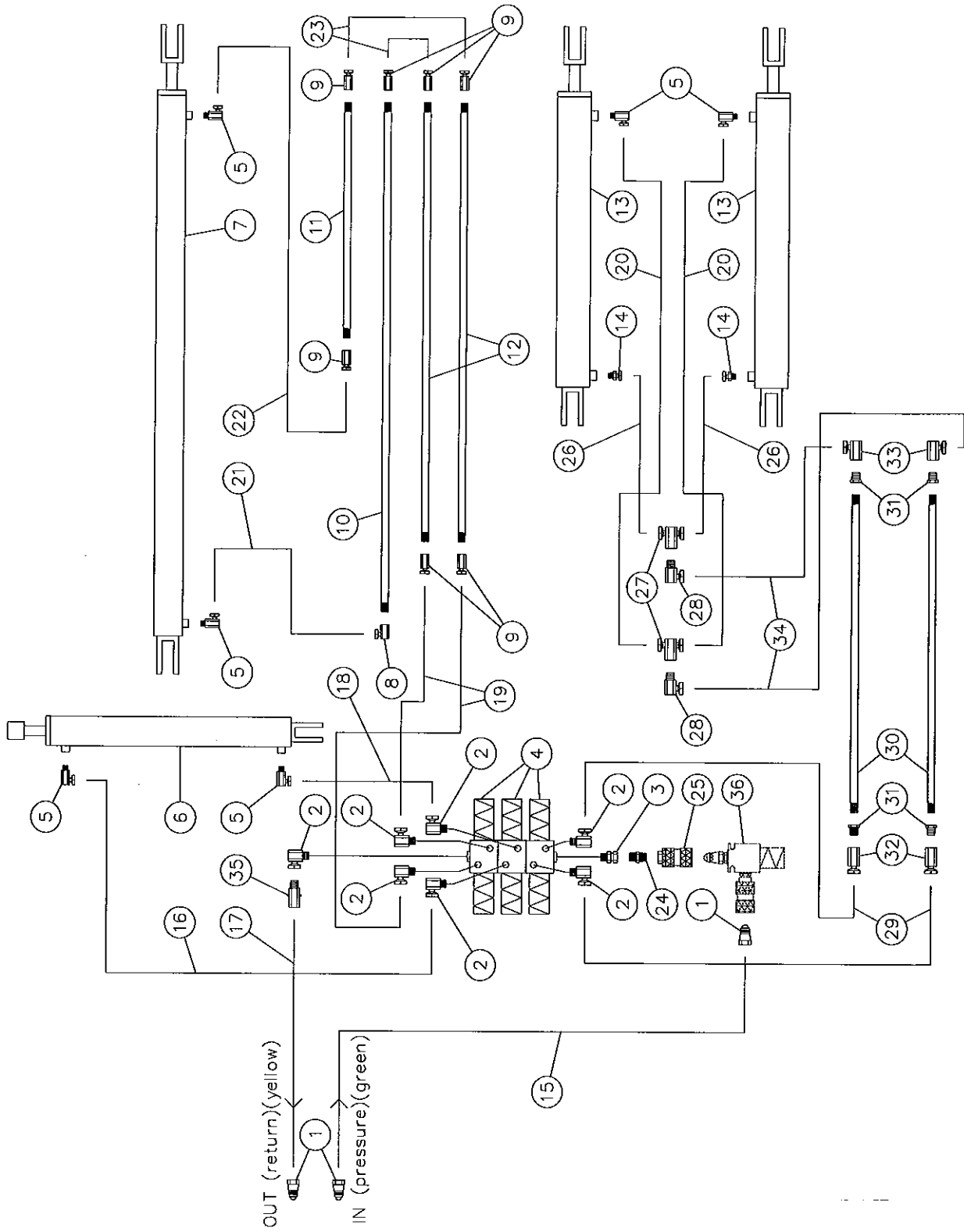

8

HYDRAULIC SYSTEM P-6807

REF.	PART #	DESCRIPTION	QTY
1	S71-4	Quick coupler 1/2" male	3
2	9515x8x8	Fitting 3/4" ORBM x 1/2" NPTF 90° swivel	7
3	9315x8x8	Fitting 3/4" ORBM x 1/2" NPTF straight swivel	1
4	18019	Solenoid valve	3
5	9405x6x6	Fitting 3/8" NPTM x 3/8" NPTF 90° swivel	6
6	30AS20	Arm cylinder	1
7	30F84	Ram cylinder	1
8	9455x6x6	Fitting 3/8" NPTF x 3/8" NPTF 90° swivel	1
9	9255x6x6	Fitting 3/8" NPTF x 3/8" NPTF straight swivel	7
10	160-01281	Hydraulic line 3/8" x 224" lg	1
11	160-01291	Hydraulic line 3/8" x 137" lg	1
12	160-01031	Hydraulic line 3/8" x 192" lg	2
13	35B24	Dumping cylinder	2
14	9205x6x6	Fitting 3/8" NPTM x 3/8" NPTF straight swivel	2
15	190-00161	Hose 1/2" x 168" lg + 2 fittings 8U108	1
16	190-00111	Hose 3/8" x 108" lg + 1 fitting 6U108 & 1 fitting 6U106	1
17	190-00091	Hose 1/2" x 180" lg + 2 fittings 8U108	1
18	190-00121	Hose 3/8" x 88" lg + 1 fitting 6U108 & 1 fitting 6U106	1
19	190-00101	Hose 3/8" x 36" lg + 1 fitting 6U108 & 1 fitting 6U106	2
20	190-00221	Hose 3/8" x 48" lg + 1 fitting 6U108 & 1 fitting 6U106	2
21	190-00141	Hose 3/8" x 20" lg + 2 fittings 6U106	1
22	190-00331	Hose 3/8" x 27" lg + 2 fittings 6U106	1
23	190-00131	Hose 3/8" x 18" lg + 2 fittings 6U106	2
24	C3069x8	Close nipple 1/2" NPTM	1
25	S75-4	Quick coupler 1/2" female	1
26	190-00231	Hose 3/8" x 26" lg + 1 fitting 6U108 & 1 fitting 6U106	2
27	15856x8x8x8	"T" 1/2" NPTF swivel	2
28	9405x8x8	Fitting 1/2" NPTM x 1/2" NPTF 90° swivel	2
29	190-00321	Hose 1/2" x 36" lg + 2 fittings 8U108	2
30	160-01021	Hydraulic line 3/8" x 162" lg	2
31	C3109 8x6	Bushing 1/2" NPTM to 3/8" NPTF	4
32	9255x8x8	Fitting 1/2" NPTF x 1/2" NPTF straight swivel	2
33	9455x8x8	Fitting 1/2" NPTF x 1/2" NPTF 90° swivel	2
34	190-00311	Hose 1/2" x 9 1/2" lg + 2 fittings 8U108	2
35	LT-50-0	Check valve 1/2" NPT	1
36	110-00651	Valve for closed center hydraulic system	opt.

8

HYDRAULIC SYSTEM P-6808

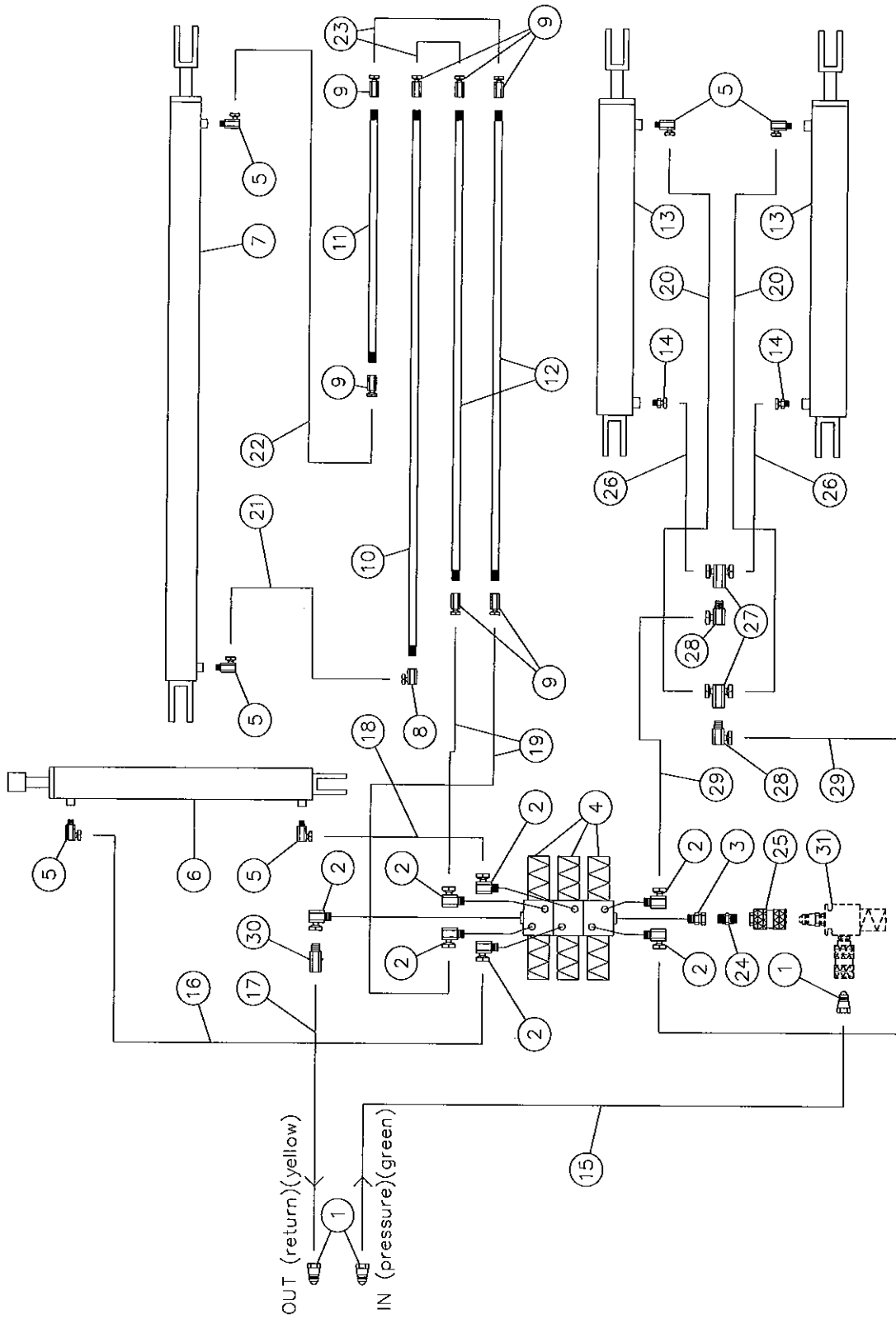

HYDRAULIC SYSTEM P-6808

REF.	PART #	DESCRIPTION	QTY
1	S71-4	Quick coupler 1/2" male	3
2	9515x8x8	Fitting 3/4" ORBM x 1/2" NPTF 90° swivel	7
3	9315x8x8	Fitting 3/4" ORBM x 1/2" NPTF straight swivel	1
4	18019	Solenoid valve	3
5	9405x6x6	Fitting 3/8" NPTM x 3/8" NPTF 90° swivel	6
6	30AS20	Arm cylinder	1
7	30F84	Ram cylinder	1
8	9455x6x6	Fitting 3/8" NPTF x 3/8" NPTF 90° swivel	1
9	9255x6x6	Fitting 3/8" NPTF x 3/8" NPTF straight swivel	7
10	160-00491	Hydraulic line 3/8" x 127" lg	1
11	160-00471	Hydraulic line 3/8" x 43" lg	1
12	160-00481	Hydraulic line 3/8" x 97" lg	2
13	35B24	Dumping cylinder	2
14	9205x6x6	Fitting 3/8" NPTM x 3/8" NPTF straight swivel	2
15	190-00161	Hose 1/2" x 168" lg + 2 fittings 8U108	1
16	190-00111	Hose 3/8" x 108" lg + 1 fitting 6U108 & 1 fitting 6U106	1
17	190-00091	Hose 1/2" x 180" lg + 2 fittings 8U108	1
18	190-00121	Hose 3/8" x 88" lg + 1 fitting 6U108 & 1 fitting 6U106	1
19	190-00101	Hose 3/8" x 36" lg + 1 fitting 6U108 & 1 fitting 6U106	2
20	190-00221	Hose 3/8" x 48" lg + 1 fitting 6U108 & 1 fitting 6U106	2
21	190-00141	Hose 3/8" x 20" lg + 2 fittings 6U106	1
22	190-00151	Hose 3/8" x 49" lg + 2 fittings 6U106	1
23	190-00131	Hose 3/8" x 18" lg + 2 fittings 6U106	2
24	C3069x8	Close nipple 1/2" NPTM	1
25	S75-4	Quick coupler 1/2" female	1
26	190-00231	Hose 3/8" x 26" lg + 1 fitting 6U108 & 1 fitting 6U106	2
27	15856x8x8x8	"T" 1/2" NPTF x 1/2" NPTF swivel	2
28	9405x8x8	Fitting 1/2" NPTM x 1/2" NPTF 90° swivel	2
29	190-00241	Hose 1/2" x 108" lg + 2 fittings 8U108	2
30	LT-50-0	Check valve 1/2" NPT	1
31	110-00651	Valve for closed center hydraulic system	opt.

HYDRAULIC SYSTEM P-6812

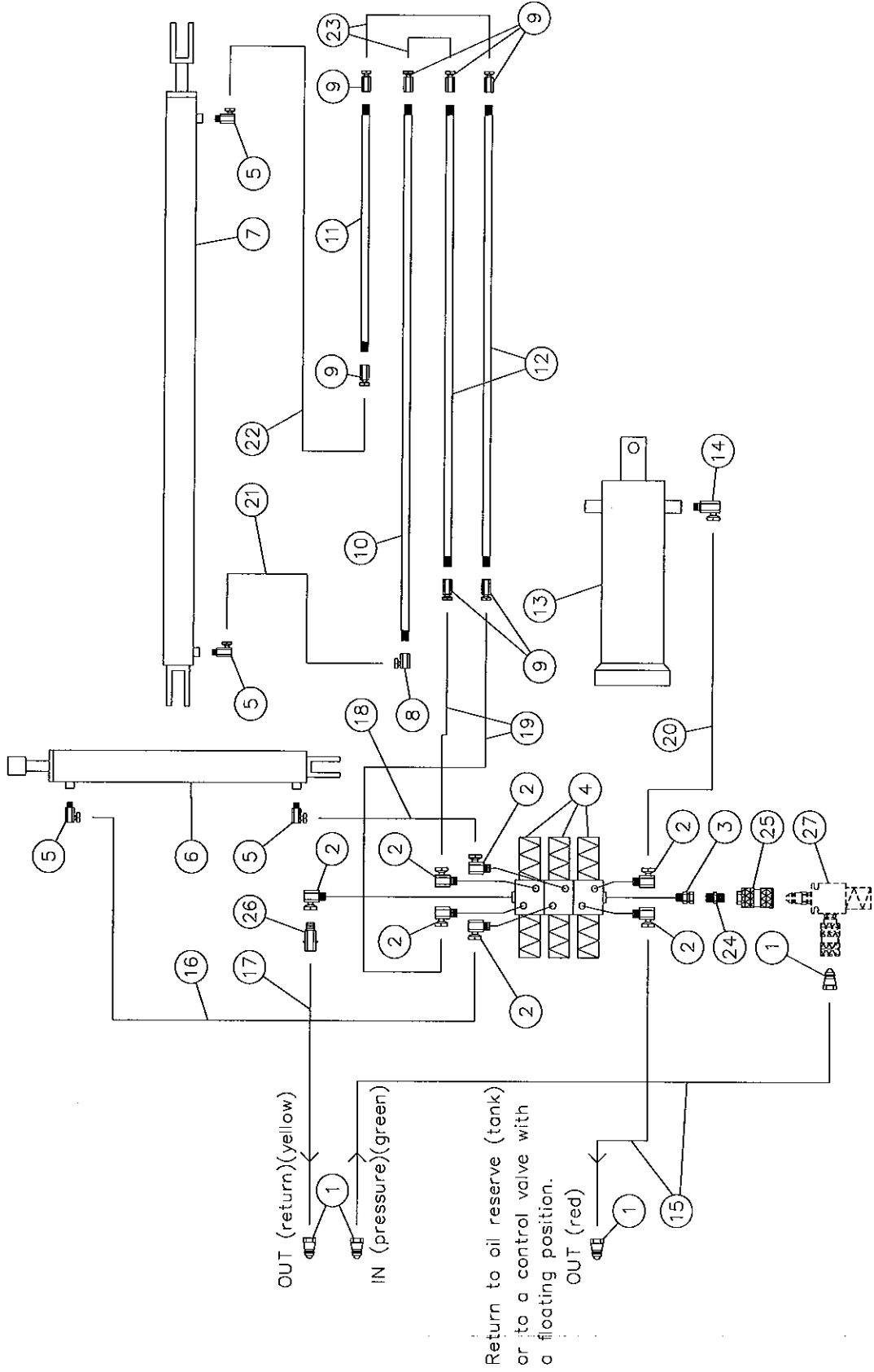

HYDRAULIC SYSTEM P-6812

REF.	PART #	DESCRIPTION	QTY
1	S71-4	Quick coupler 1/2" male	4
2	9515x8x8	Fitting 3/4" ORBM x 1/2" NPTF 90° swivel	7
3	9315x8x8	Fitting 3/4" ORBM x 1/2" NPTF straight swivel	1
4	18019	Solenoid valve	3
5	9405x6x6	Fitting 3/8" NPTM x 3/8" NPTF 90° swivel	4
6	30AS20	Arm cylinder	1
7	30F84	Ram cylinder	1
8	9455x6x6	Fitting 3/8" NPTF x 3/8" NPTF 90° swivel	1
9	9255x6x6	Fitting 3/8" NPTF x 3/8" NPTF straight swivel	7
10	160-01031	Hydraulic line 3/8" x 192" lg	1
11	160-01001	Hydraulic line 3/8" x 108" lg	1
12	160-01021	Hydraulic line 3/8" x 162" lg	2
13	110-00471	Telescopic cylinder	1
14	9205x8x8	Fitting 3/8" NPTM x 1/2" NPTF 90° swivel	2
15	190-00161	Hose 1/2" x 168" lg + 2 fittings 8U108	2
16	190-00111	Hose 3/8" x 108" lg + 1 fitting 6U108 & 1 fitting 6U106	1
17	190-00091	Hose 1/2" x 180" lg + 2 fittings 8U108	1
18	190-00121	Hose 3/8" x 88" lg + 1 fitting 6U108 & 1 fitting 6U106	1
19	190-00101	Hose 3/8" x 36" lg + 1 fitting 6U108 & 1 fitting 6U106	2
20	190-00171	Hose 1/2" x 49" lg + 2 fittings 8U108	2
21	190-00141	Hose 3/8" x 20" lg + 2 fittings 6U106	1
22	190-00151	Hose 3/8" x 49" lg + 2 fittings 6U106	1
23	190-00131	Hose 3/8" x 18" lg + 2 fittings 6U106	2
24	C3069x8	Close nipple 1/2" NPTM	1
25	S75-4	Quick coupler 1/2" female	1
26	LT-50-0	Check valve 1/2" NPT	1
27	110-00651	Valve for closed center hydraulic system	opt.

HYDRAULIC SYSTEM P-6816

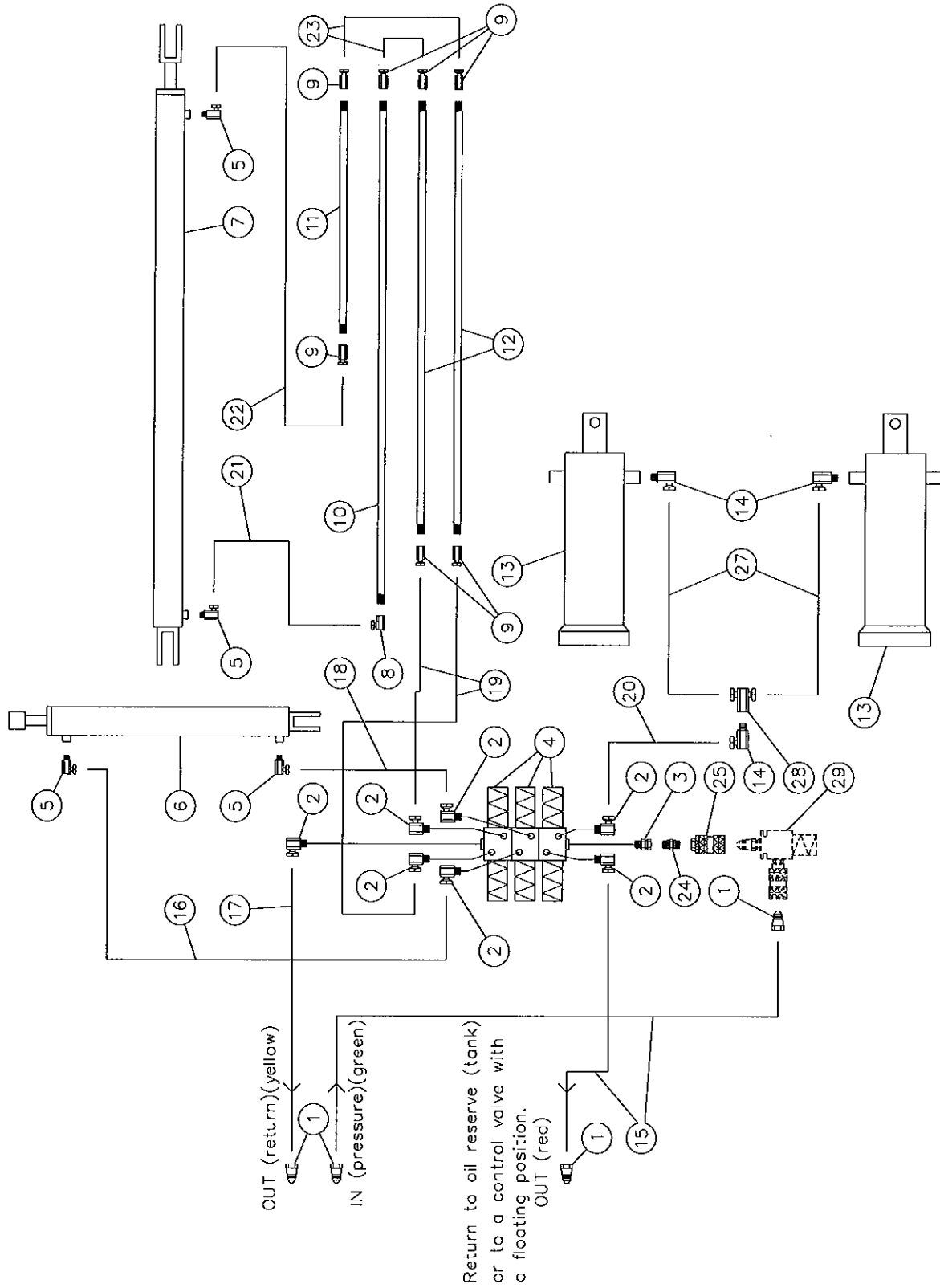

HYDRAULIC SYSTEM P-6816

REF.	PART #	DESCRIPTION	QTY
1	S71-4	Quick coupler 1/2" male.....	4
2	9515x8x8	Fitting 3/4" ORBM x 1/2" NPTF 90° swivel	7
3	9315x8x8	Fitting 3/4" ORBM x 1/2" NPTF straight swivel	1
4	18019	Solenoid valve	3
5	9405x6x6	Fitting 3/8" NPTM x 3/8" NPTF 90° swivel.....	4
6	30AS20	Arm cylinder	1
7	30F84	Ram cylinder	1
8	9455x6x6	Fitting 3/8" NPTF x 3/8" NPTF 90° swivel.....	1
9	9255x6x6	Fitting 3/8" NPTF x 3/8" NPTF straight swivel.....	7
10	160-01301	Hydraulic line 3/8" x 288" lg	1
11	160-01311	Hydraulic line 3/8" x 204" lg	1
12	160-01321	Hydraulic line 3/8" x 258" lg	2
13	110-00471	Telescopic cylinder	2
14	9405x8x8	Fitting 1/2" NPTM x 1/2" NPTF 90° swivel.....	3
15	190-00161	Hose 1/2" x 168" lg + 2 fittings 8U108	2
16	190-00111	Hose 3/8" x 108" lg + 1 fitting 6U108 & 1 fitting 6U106.....	1
17	190-00091	Hose 1/2" x 180" lg + 2 fittings 8U108	1
18	190-00121	Hose 3/8" x 88" lg + 1 fitting 6U108 & 1 fitting 6U106.....	1
19	190-00101	Hose 3/8" x 36" lg + 1 fitting 6U108 & 1 fitting 6U106.....	2
20	190-00351	Hose 1/2" x 158" lg + 2 fittings 8U108	1
21	190-00141	Hose 3/8" x 20" lg + 2 fittings 6U106	1
22	190-00151	Hose 3/8" x 49" lg + 2 fittings 6U106	1
23	190-00131	Hose 3/8" x 18" lg + 2 fittings 6U106	2
24	C3069x8	Close nipple 1/2" NPTM	1
25	S75-4	Quick coupler 1/2" female	1
26	LT-50-0	Check valve 1/2" NPT.....	1
27	190-00341	Hose 1/2" x 34" lg + 2 fittings 8U108	2
28	15856x8x8x8	"T" 1/2" NPTF x 1/2" NPTF swivel	1
29	110-00651	Valve for closed center hydraulic system	opt.

CYLINDER 30AS20

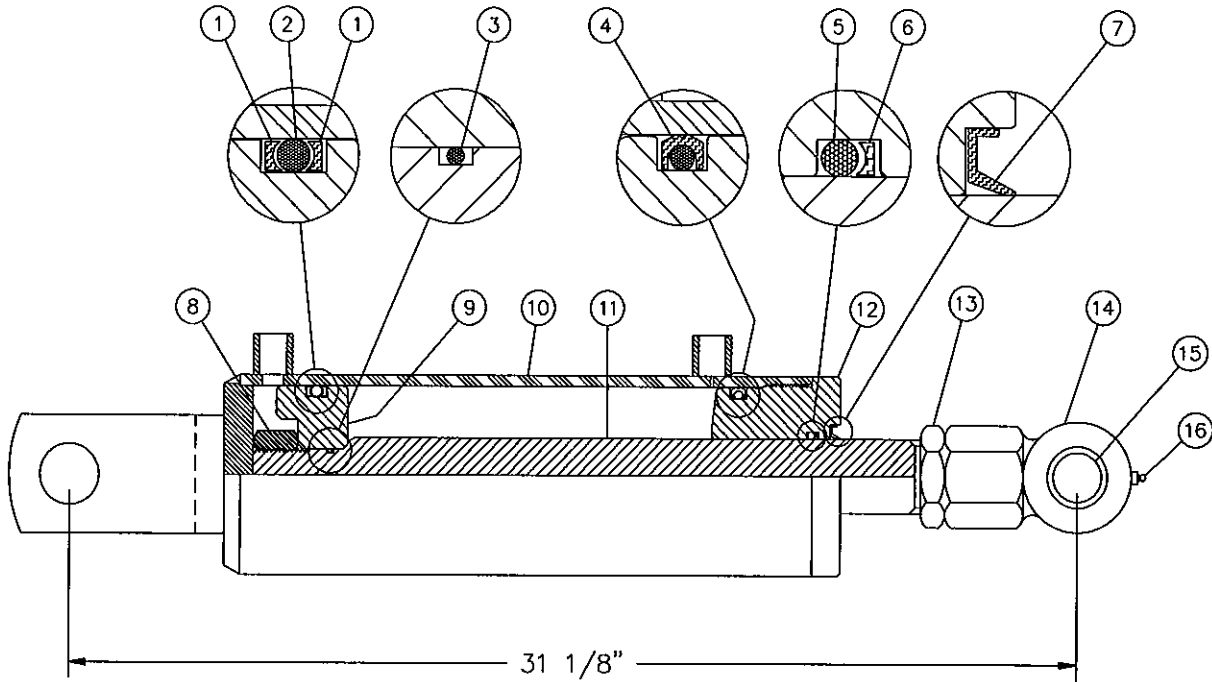

8

REF.	PART #	DESCRIPTION	QTY
1	BU-334	Back-up ring 3/16" x 2 5/8" x 3"	2
2	OR-334	O-ring 3/16" x 2 5/8" x 3"	1
3	OR-018	O-ring 1/16" x 3/4" x 7/8"	1
4	PSP-334	O-ring 3/16" x 2 5/8" x 3"	1
5	OR-218	O-ring 1/8" x 1 1/2" x 1 3/4"	1
6	BU-218	Back-up 1/8" x 1 1/2" x 1 3/4"	1
7	AR-2269Fo	Wiper 1/8" x 1 1/2" x 2"	1
8	Std.	Nut 7/8" - 14NF	1
9	D-6000	Piston 3" dia.	1
10	D-6156	Cylinder body 3" dia.	1
11	D-1000171	Piston rod 1 1/2" x 27 1/8"	1
12	D-1000171	Head 3" dia.	1
13	D-1000171	Nut 1 1/2" - 12 x 1 1/2"	1
14	D-1000171	Piston rod end 1 1/2" - 12 x 1 5/8"	1
15	D-1000171	Brass bushing 1" i.d. x 1 1/4" o.d. x 2 1/2"	1
16	D-1000171	Grease fitting 1/4" - 28 straight	1

CYLINDER 35BS24

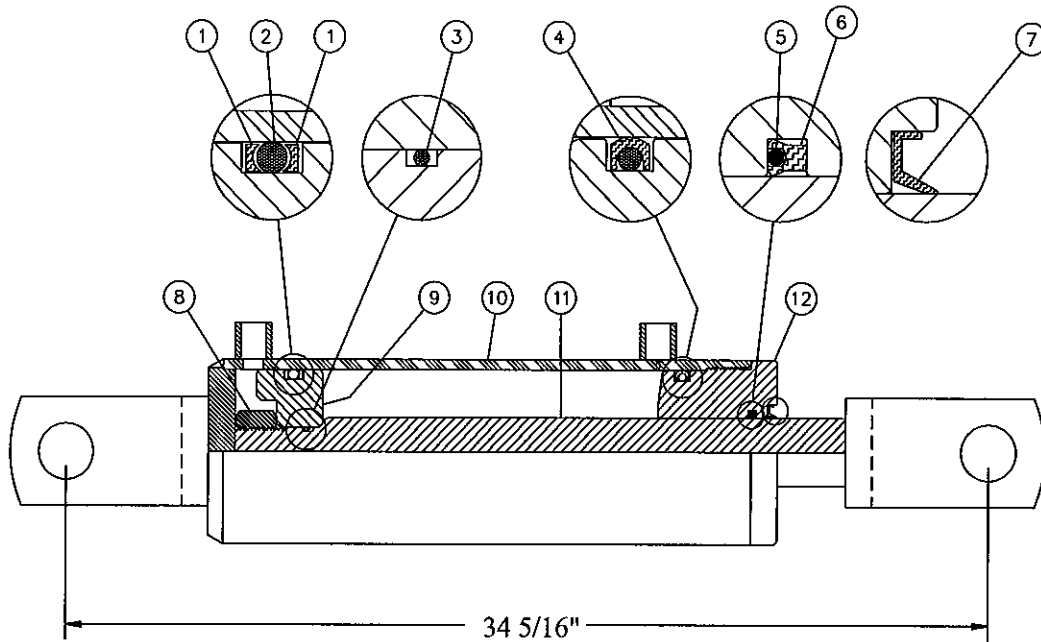

REF.	PART #	DESCRIPTION	QTY
1	BU-338	Back-up ring 3/16" x 3 1/8" x 3 1/2"	2
2	OR-338	O-ring 3/16" x 3 1/8" x 3 1/2"	1
3	OR-018	O-ring 1/16" x 3/4" x 7/8"	1
4	PSP-338	O-ring 3/16" x 3 1/8" x 3 1/2"	1
5	OR-222	O-ring 1/8" x 1 1/2" x 1 3/4"	1
6	BU-222	Back-up 1/8" x 1 1/2" x 1 3/4"	1
7	AR-2269F0	Wiper 1/8" x 1 1/2" x 1 3/4"	1
8	Std.	Nut 7/8" - 14NF	1
9	D-6113	Piston 3 1/2" dia.	1
10	D-A6157	Cylinder body 3 1/2" dia.	1
11	D-A6158	Piston rod 1 1/2" x 28 9/16"	1
12	D-6114	Head 3 1/2" dia.	1

8

CYLINDER 30F84

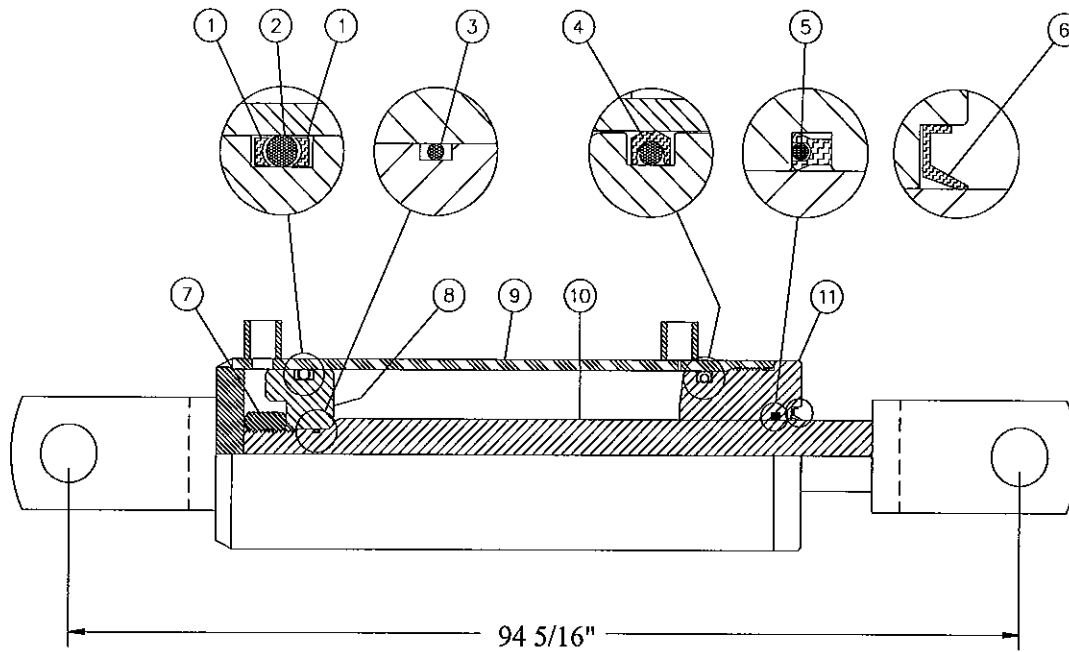

REF.	PART #	DESCRIPTION	QTY
1	BU-334	Back-up ring 3/16" x 2 5/8" x 3"	2
2	OR-334	O-ring 3/16" x 2 5/8" x 3"	1
3	OR-018	O-ring 1/16" x 3/4" x 7/8"	1
4	PSP-334	O-ring 3/16" x 2 5/8" x 3"	1
5	3C-375	U-cup 1 3/4" x 2 1/4"	1
6	CR-17240	Wiper 5/16" x 1 3/4" x 2 1/4"	1
7	Std.	Nut 7/8" - 14NF	1
8	D-6000	Piston 3" dia.	1
9	D-A6127	Cylinder body 3" dia.	1
10	D-6126	Piston rod 1 3/4" x 85 9/16"	1
11	D-6106	Head 3" dia.	1

8

TELESCOPIC CYLINDER 110-00471

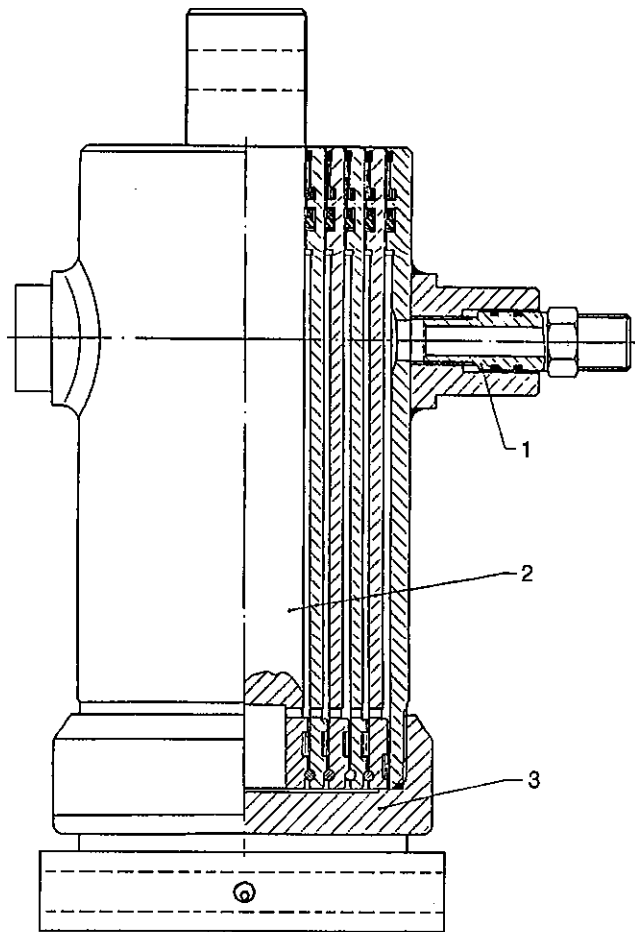

REF.	PART #	DESCRIPTION	QTY
1	51586	Connector	1
2	51595	Piston	1
3	51596	Threaded cylinder base	1
NI*	51597	Repair kit for cylinder	1
NI*	51589	Seal kit for connector	1

8

HUBS H5000 H8000 H10000

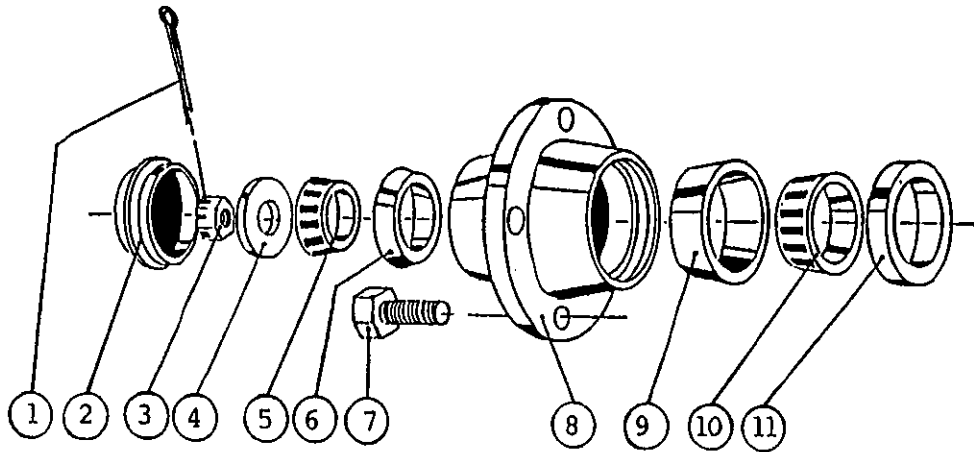







REF.	PART #	DESCRIPTION	QTY		
			H-5000	H-8000	H-10000
1	Std.	Cotter pin 5/32" x 1 1/2"	1	-	-
1	Std.	Cotter pin 3/16" x 2 1/2"	-	1	-
1	Std.	Cotter pin 1/4" x 3"	-	-	1
2	51417	Dust cap 2.570" ø	1	-	-
2	36114	Dust cap 3.135" ø	-	1	-
2	36115	Dust cap 3.360" ø	-	-	1
3	51442	Castle nut 7/8" NF	1	-	-
3	36116	Castle nut 1" - 14	-	1	-
3	36117	Castle nut 1 1/4" - 12	-	-	1
4	Std.	Flat washer 7/8"	1	-	-
4	Std.	Flat washer 1"	-	1	-
4	Std.	Flat washer 1 1/4"	-	-	1
5	51416	Roller bearing Timken: cone no. 4T-LM48548	1	-	-
5	36118	Roller bearing Timken: cone no. LM 501349	-	1	-
5	36119	Roller bearing Timken: cone no. 4T-25580	-	-	1
6	51415	Roller bearing Timken: cup no. 4T-LM48510	1	-	-
6	36120	Roller bearing Timken: cup no. LM 501310	-	1	-
6	36121	Roller bearing Timken: cup no. 4T-25520	-	-	1
7	51418	Rim screw 9/16"	6	-	-
7	36122	Rim screw 5/8" x 2-1/8	-	8	8
8	51414	Hub only H5000	1	-	-
8	36123	Hub only H8000	-	1	-
8	36124	Hub only H10000	-	-	1
9	51413	Roller bearing Timken: cup no. 4T-LM603011	1	-	-
9	36125	Roller bearing Timken: cup no. LM 506810	-	1	-
9	36126	Roller bearing Timken: cup no. 4T-28921	-	-	1
10	51412	Roller bearing Timken: cone no. 4T-LM603049	1	-	-
10	36127	Roller bearing Timken: cone no. LM 506849	-	1	-
10	36128	Roller bearing Timken: cone no. 4T-28995	-	-	1
11	51443	Oil seal no. CR20044	1	-	-
11	36129	Oil seal no. CR27361	-	1	-
11	36130	Oil seal no. CR29273	-	-	1





8

TORQUE CHART

TORQUE SPECIFICATION TABLE

Thread UNC and UNF		Grade 2 				Grade 5   				Grade 8*   			
Bolt size		Torque				Torque				Torque			
Inches	mm	Pound feet		Newton meters		Pound feet		Newton meters		Pound feet		Newton meters	
		min.	max.	min.	max.	min.	max.	min.	max.	min.	max.	min.	max.
1/4	6.35	5	6	6.8	8.13	9	11	12.2	14.9	12	15	16.3	30.3
5/16	7.94	10	12	13.6	16.3	17	20.5	23.1	27.8	24	29	32.5	39.3
3/8	9.53	20	23	27.1	31.2	35	42	47.5	57.0	45	54	61.0	73.2
7/16	11.11	30	35	40.7	47.4	54	64	73.2	86.8	70	84	94.9	113.9
1/2	12.70	45	52	61.0	70.5	80	96	108.5	130.2	110	132	149.2	179.0
9/16	14.29	65	75	88.1	101.6	110	132	149.2	179.0	160	192	217.0	260.4
5/8	15.88	95	105	128.7	142.3	150	180	203.4	244.1	220	264	298.3	358.0
3/4	19.05	150	185	203.3	250.7	270	324	366.1	439.3	380	456	515.3	618.3
7/8	22.23	160	200	216.8	271.0	400	480	542.4	650.9	600	720	813.6	976.3
1	25.40	250	300	338.8	406.5	580	696	786.5	943.8	900	1080	1220.4	1464.5
1 1/8	25.58	-	-	-	-	800	880	1084.8	1193.3	1280	1440	1735.7	1952.6
1 1/4	31.75	-	-	-	-	1120	1240	1518.7	1681.4	1820	2000	2467.9	2712.0
1 3/8	34.93	-	-	-	-	1460	1680	1979.8	2278.1	2380	2720	3227.3	3688.3
1 1/2	38.10	-	-	-	-	1940	2200	2630.6	2983.2	3160	3560	4285.0	4827.4

* Thick nuts must be used with grade 8 bolts.

Size of screw	Thread	Pitch (mm)	Grade 4T  				Grade 7T 				Grade 8T  			
			Torque				Torque				Torque			
			Pound feet		Newton meters		Pound feet		Newton meters		Pound feet		Newton meters	
		min.	max.	min.	max.	min.	max.	min.	max.	min.	max.	min.	max.	
M6	UNC	1.00	3.6	5.8	4.9	7.9	5.8	9.4	7.9	12.7	7.2	10	9.8	13.6
M8	UNC	1.25	7.2	14	9.8	19	17	22	23	29.8	20	26	27.1	35.2
M10	UNC	1.5	20	25	27.1	33.9	34	40	46.1	54.2	38	46	51.5	62.3
M12	UNC	1.75	28	34	37.9	46.1	51	59	69.1	79.9	57	66	77.2	89.4
M14	UNC	2.0	49	56	66.4	75.9	81	93	109.8	126	96	109	130.1	147.7
M16	UNC	2.0	67	77	90.8	104.3	116	130	157.2	176.2	129	145	174.8	196.5
M18	UNC	2.0	88	100	119.2	136	150	168	203.3	227.6	175	194	237.1	262.9
M20	UNC	2.5	108	130	146.3	176.2	186	205	252	277.8	213	249	288.6	337.4
M8	UNF	1.0	12	17	16.3	23	19	27	25.7	36.6	22	31	29.8	42
M10	UNF	1.25	20	29	27.1	39.3	35	47	47.4	63.7	40	52	54.2	70.5
M12	UNF	1.25	31	41	42	55.6	56	68	75.9	92.1	62	75	84	101.6
M14	UNF	1.5	52	64	70.5	86.7	90	106	122	143.6	107	124	145	168
M16	UNF	1.5	69	83	93.5	112.5	120	138	162.6	187	140	158	189.7	214.1
M18	UNF	1.5	100	117	136	158.5	177	199	239.8	269.6	202	231	273.7	313
M20	UNF	1.5	132	150	178.9	203.3	206	242	279.1	327.9	246	289	333.3	391.6

Use the above torques when special torque is not given.

NOTE: These values apply to fasteners as received from supplier, dry, or when lubricated with normal engine oil. They do not apply if extreme pressure lubricants are used.

WARRANTY

PRONOVOST warrants this product to the initial purchaser for the period of one year from the date of purchase against defects in materials and workmanship.

We will replace or repair defective parts free of charge if they are returned to our plant in St-Tite, Quebec, Canada.

Transportation charges are the responsibility of the customer. This warranty is not transferable.

Tires are covered by the manufacturers of these items.

All PRONOVOST spare parts purchased are covered by a three (3) month warranty.

This warranty becomes void and nul if the equipment is modified, breaks down as result of an accident, if not operated according to manufacturer's recommendations, damaged by negligence or if maintenance has not been carried out as specified.

Our obligation is limited to the replacement or repair of the defective part. PRONOVOST accepts no responsibility for direct or indirect consequential damages of any kind.

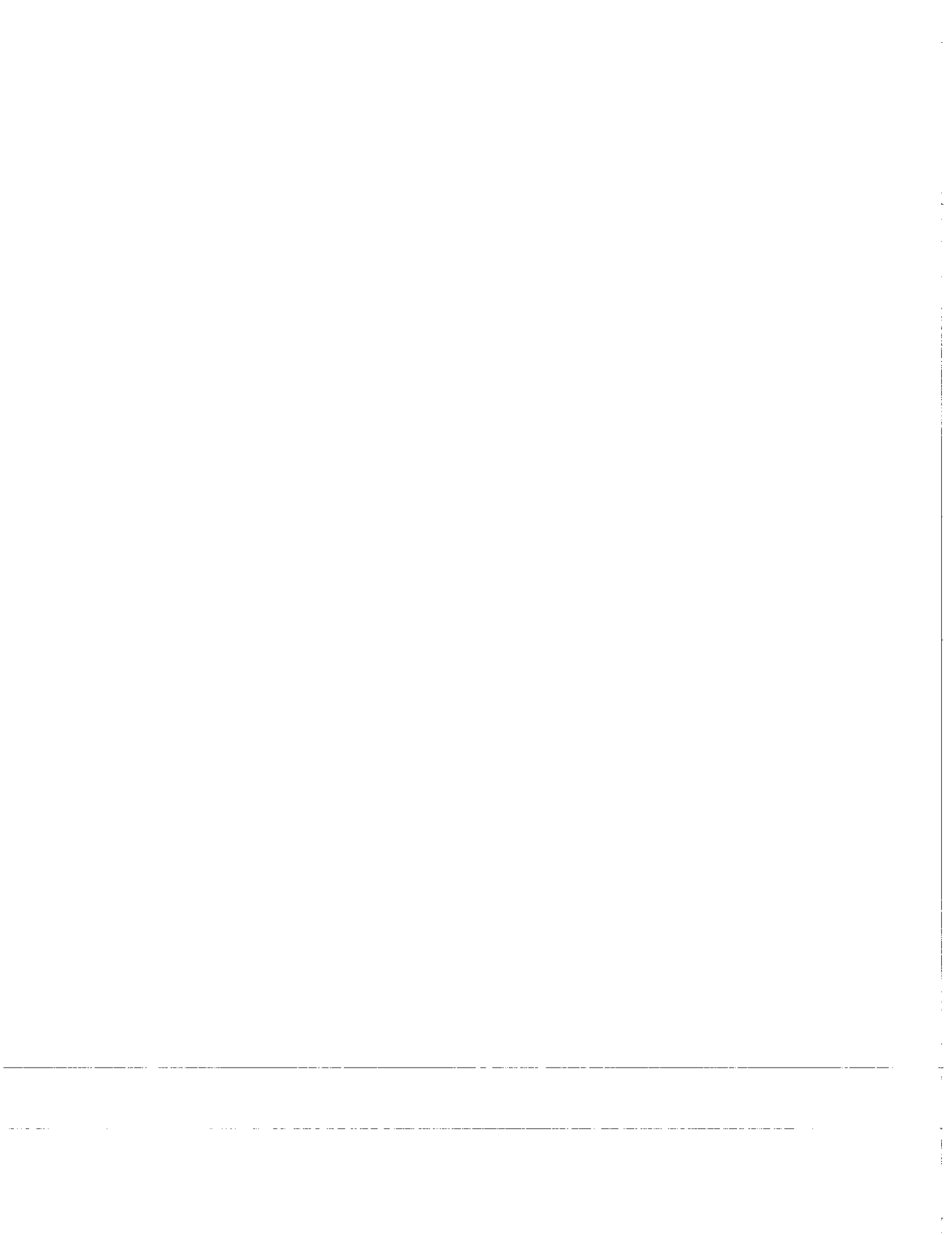

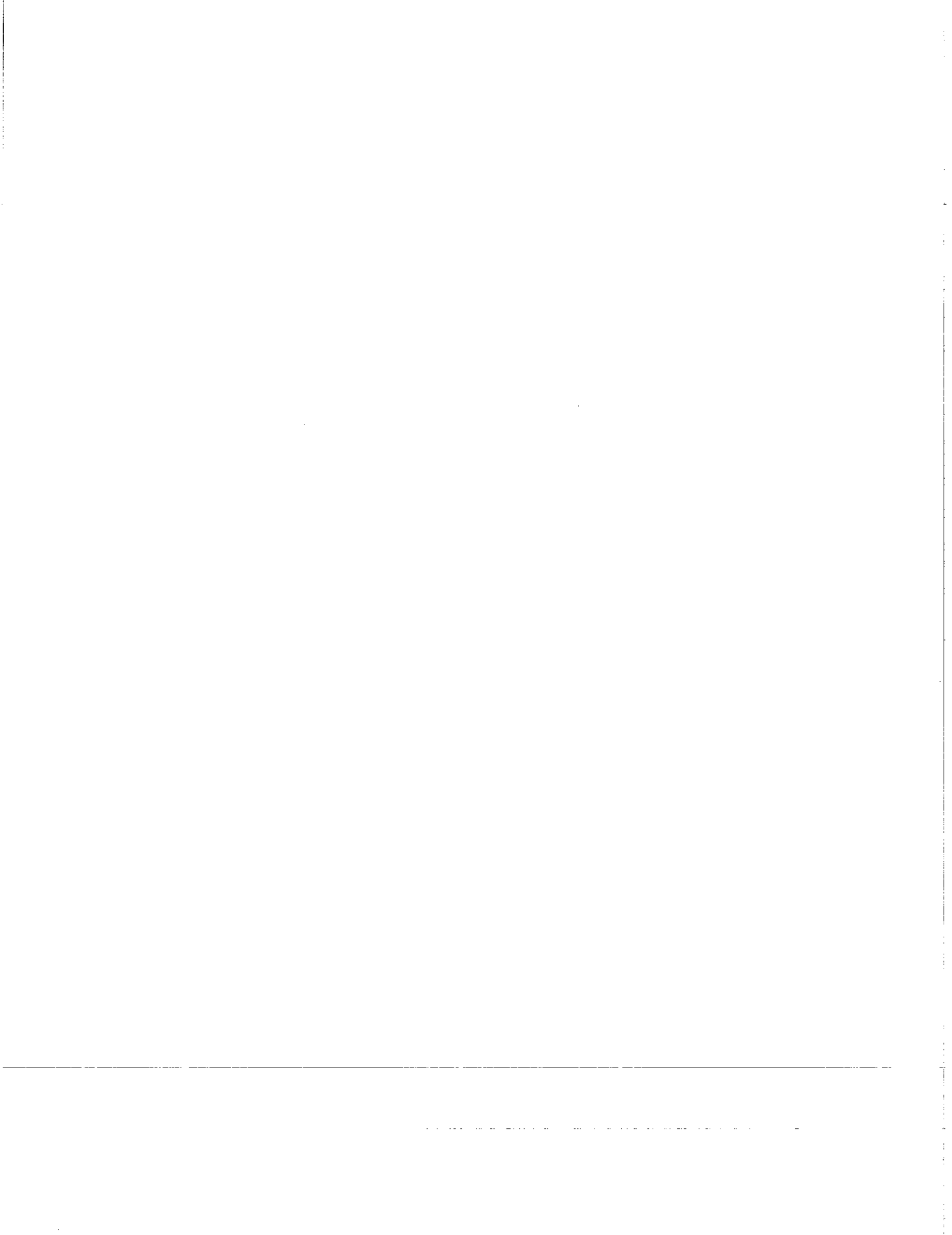

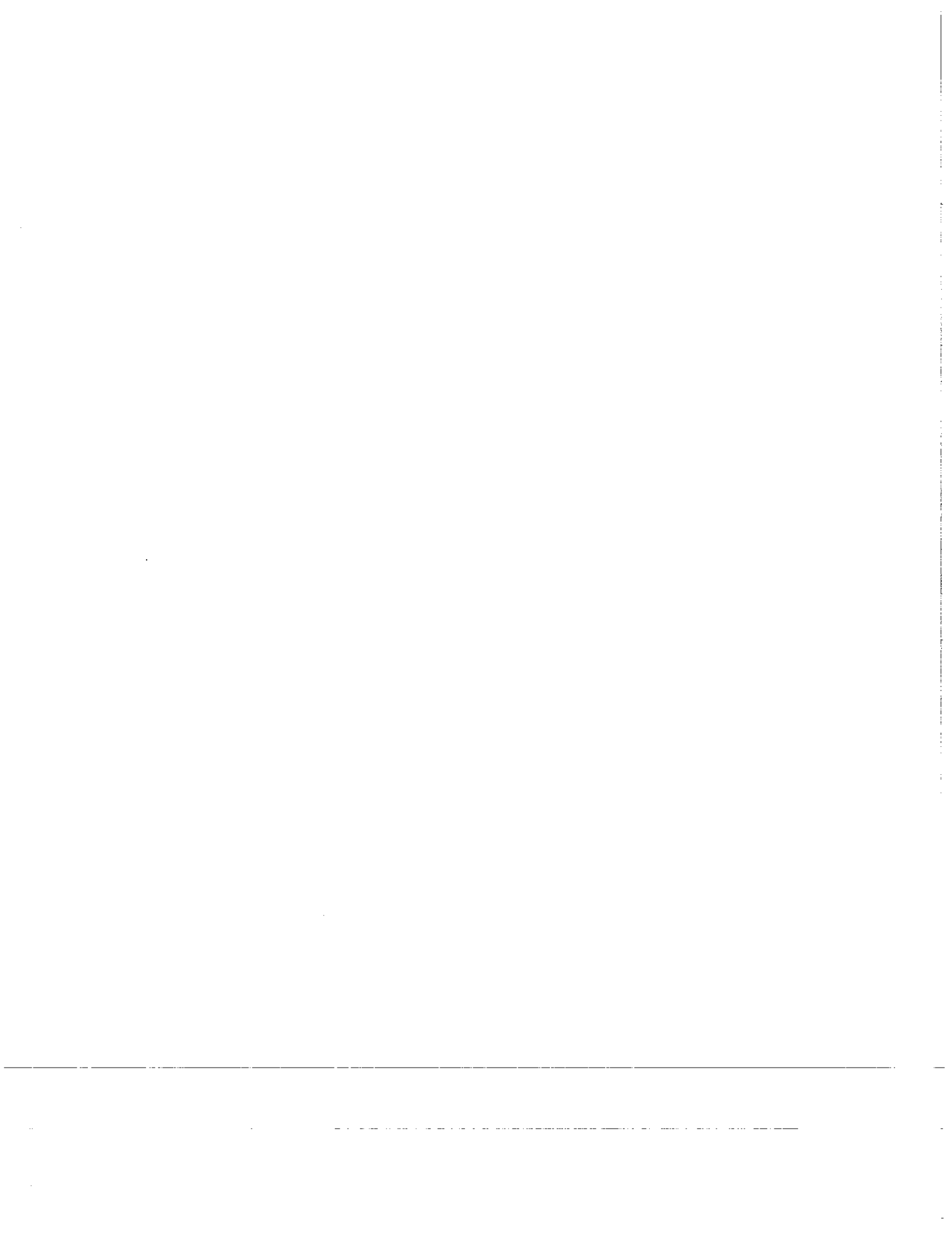

Ce manuel est aussi disponible en français.
Veuillez téléphoner.



LES MACHINERIES PRONOVOST INC.
260, route 159,
Saint-Tite, Quebec, Canada, G0X 3H0...
Tel.: (418) 365-7551, Fax: (418) 365-7954