



AGLAND INDUSTRIES INC.

POWERMERGER6618

***Operator's Manual &
Parts Catalogue***
July 2009



AgLand
INDUSTRIES INC.

Replacement Parts

To obtain prompt, efficient service, give your dealer the following information.

1. Correct stock number.
2. Model number of the machine.
3. Serial number of the Macerator.

The serial number is important in identifying your machine. It contains information for ordering replacement parts and options which may vary depending on the serial number identification.

Measurements are given in U.S. units followed by the equivalent in metric units. Hardware sizes are given in inches for U.S. hardware and millimeters for metric hardware.

All nuts and bolts are specified in Grade 5 unless otherwise indicated.

Warranty Registration Form	3
Introduction.....	5
Assembly Instructions	6-14
Assembly Procedure.....	6
Conveyor Assembly.....	10
Hydraulic Motor Assembly	11
Hydraulic Fittings and Hoses.....	12
Hydraulic Hose Routing.....	13
Adjustable Arm Stops.....	14
Maintenance	15
Parts Catalogue	17-24
Conveyor.....	18
Power Merger Kit K108	20
Weight Holder	22
Hydraulics	24
Warranty	Back Cover

Congratulations, you have just purchased the new Power Merger 6618 attachment for the AgLand Macerator* 6610 and 6620. To get the maximum benefit from your Power Merger we suggest that you read this manual carefully.



The Power Merger 6618 is designed to merge a macerated swath to lay beside or on top of an existing swath to enhance or shorten the length of drying time.

The macerated swath can be merged either to the left or right side by reversing the conveyors hydraulic motor.

In the operating mode, the conveyor runs at an approximate 10-12 degree angle when resting on the arm stops. This angle is to achieve a proper attitude for conveying and merging crop material.

The reference to left side and right side is determined when facing the direction of travel during operation of the Macerator and Power Merger.

NOTE: PAY SPECIAL ATTENTION TO THE SAFETY SECTION of the Macerator 6610 or 6620 Operator's Manual in order to understand the SAFETY CAUTIONS of this attachment.

* This attachment to be installed only on the 2006 and later 6610 and 6620 Macerator models.

The photographs, illustrations, and data used in this manual were current at the time of printing, but due to possible in-line production changes, your machine may vary slightly in detail. The Manufacturer reserves the right to redesign and change the machine as necessary without notification.

WARNING

Some pictures in this manual show the machine with shields removed to allow for a better view of the subject. The machine must never be operated with any of the shields removed.

AgLand Industries Inc. is a Canadian owned and operated company located in central Canada, in the province of Manitoba. AgLand was founded in 2001 by a group of innovative entrepreneurs that transformed their ideas and expertise into a leading manufacturing company of agricultural crop equipment.

Box 479, Arborg, MB, Canada ROC OAO

Tel: 204.364.2211

Fax: 204.364.2472

Email: sales@aglandindustries.com

Web: www.aglandindustries.com



Assembly Instructions

The Power Merger attachment is shipped partially assembled as follows:

1. Conveyor Assembly - assembled except for Hydraulic Motor Drive.
2. Main Tube and Hook Arm(s) (left and right) - not assembled.
3. Conveyor Lift Arms (4) and Hydraulic Lift Tube - not assembled.
4. Lift Arm Stop Bumper Assemblies - not assembled.
5. Hydraulics - including Hydraulic Lift Cylinder, Drive Motor and Hydraulic Hoses - not assembled.
6. Counter Weight Frame Assembly - not assembled.
7. Windrower attachment, if not equipped with previously - not assembled.

This attachment to be installed only on the 2006 and later 6610 and 6620 Macerator models.

Tractor must be attached to the Macerator during assembly of the Power Merger to prevent the Macerator from becoming unstable.

Assembly Procedure

Assemble parts onto Macerator as follows:

1. Install the counter weight frame on hitch A-frame, see Figure 1.

Add two 100 lb (46 kg) tractor suit-case weights (or equivalent), one on each side to keep the Macerator in balance BEFORE installing the conveyor assembly.

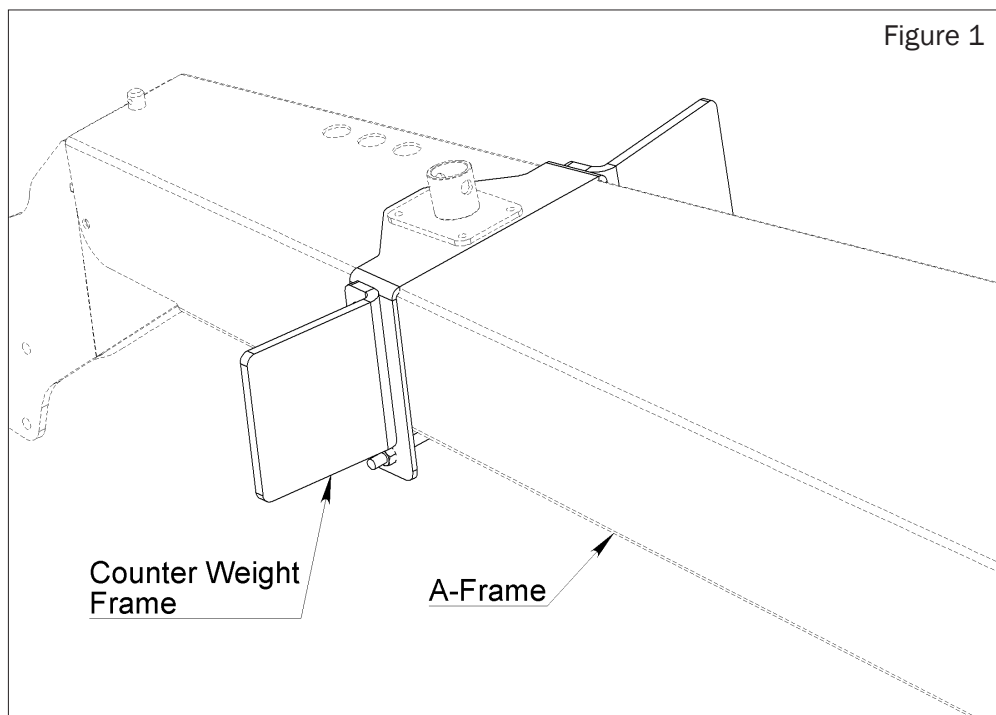

2. Install nylon bushings into left side and right side hook arms, see Figure 2.

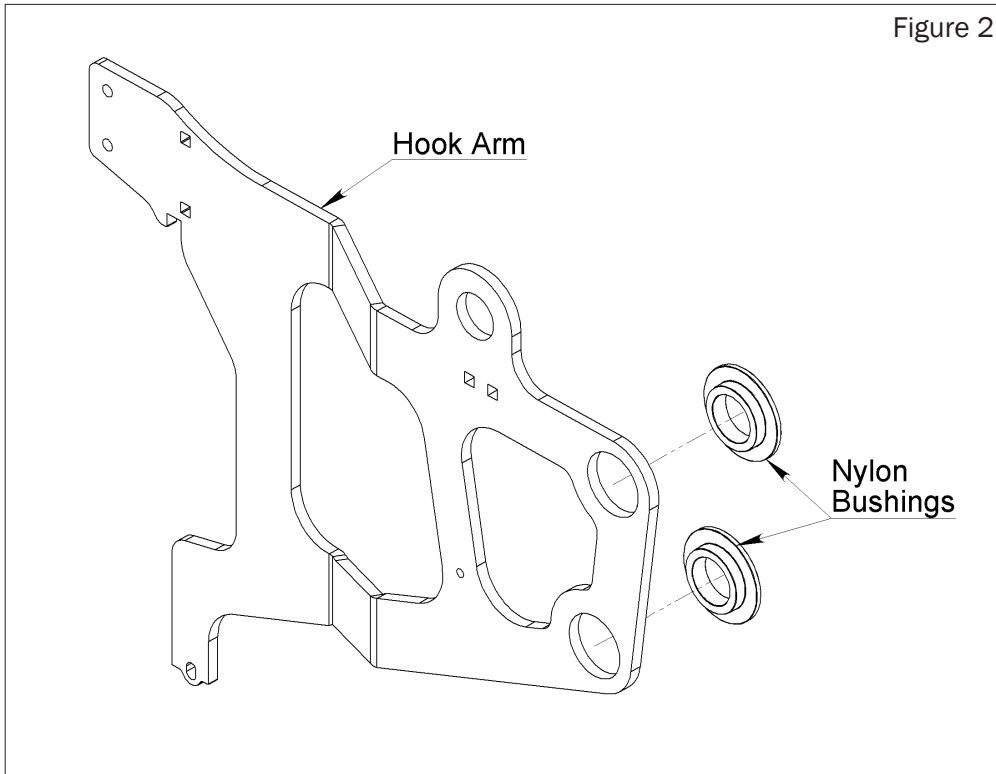

3. Assemble and install main frame tube, hook arms and stabilizer braces to hook arms at rear of Macerator. Leave bolts loose until all frame and arm assemblies are installed, see Figure 3.

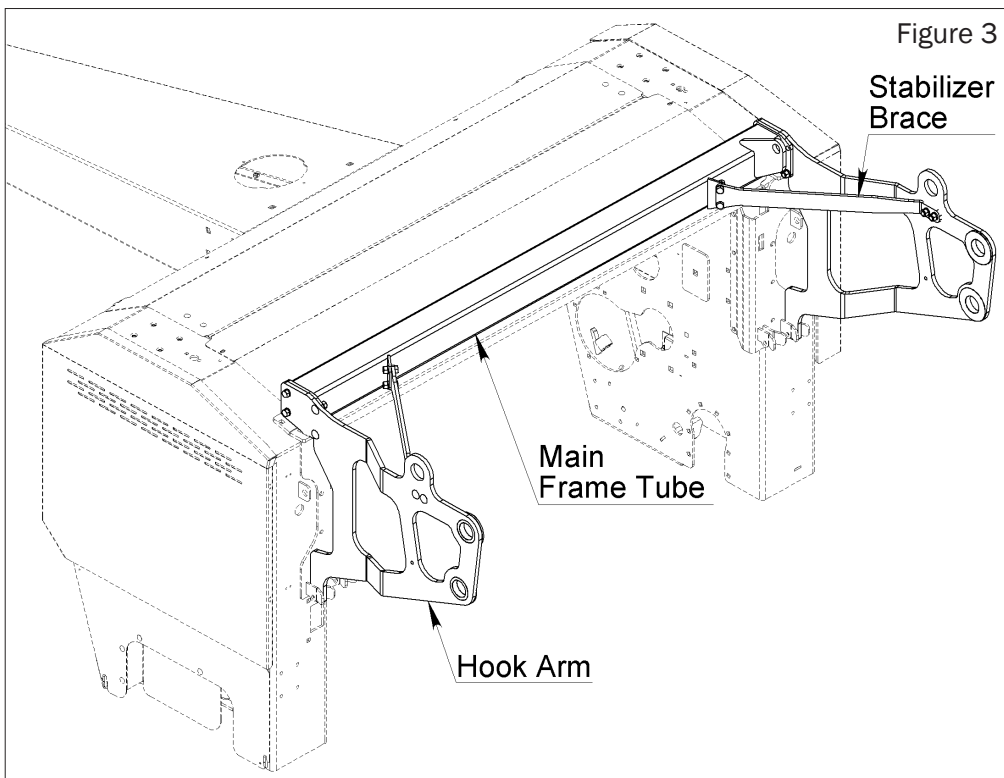

Assembly Instructions

4. Install hydraulic lift tube, front and rear conveyor lift arms and lift arm bumper stops. Tighten all frame bolts, see Figure 4.

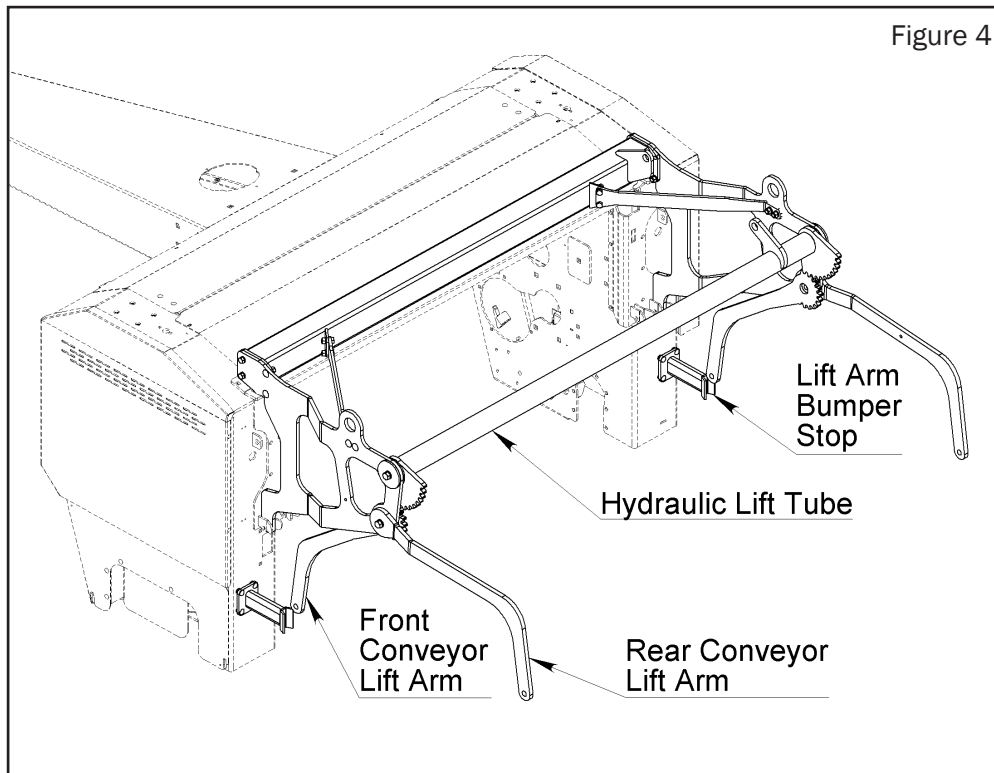

5. Install bottom locking lynch pins, see Figure 5.

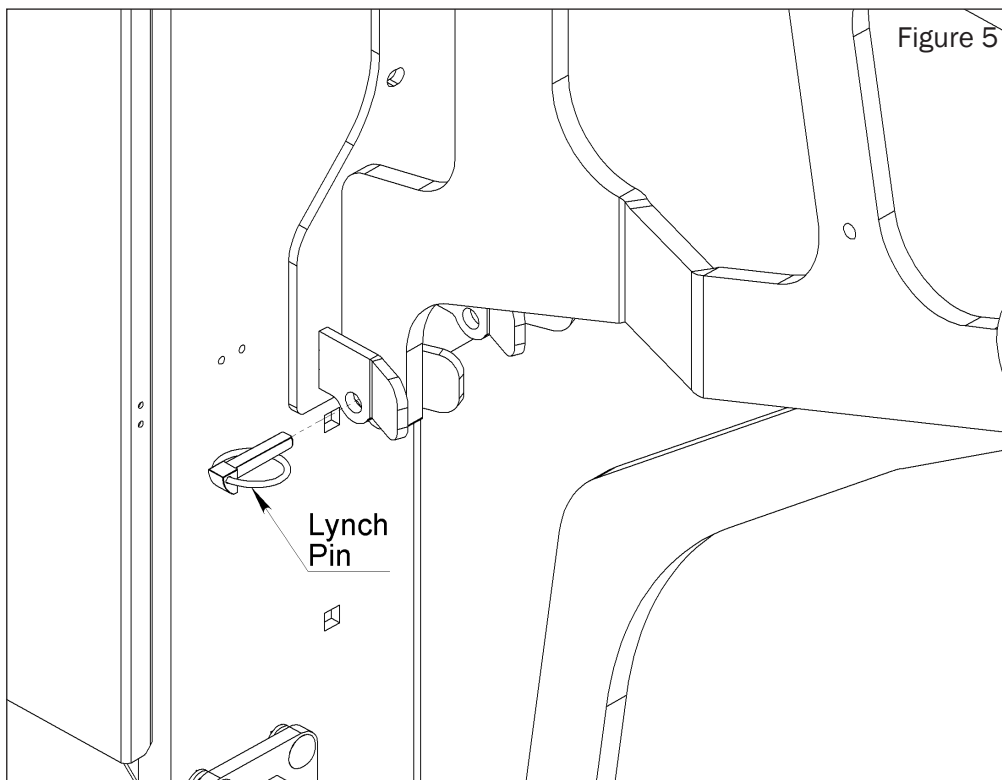

6. Install hydraulic cylinder and leave in fully retracted (in) position. Ensure index lift arm gear teeth with front arms are fully down against bumper stops, see Figure 6.

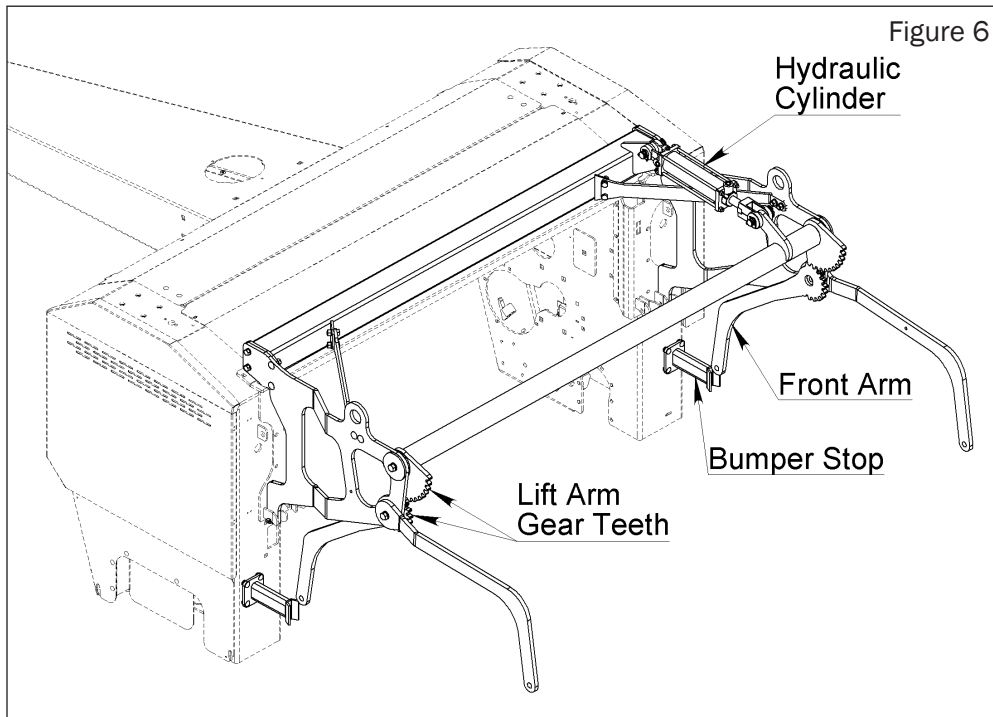

7. Assemble windrower with 10 degree hook mounting plates (supplied with sundry parts). Install windrower onto Macerator, see Figure 7.

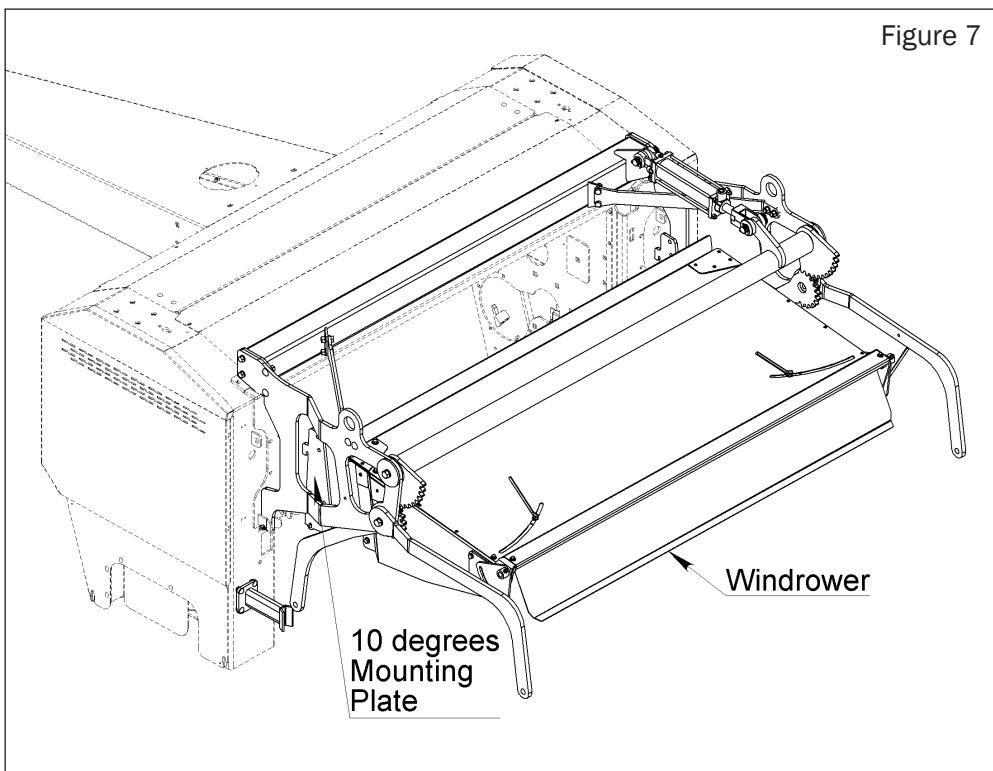

Assembly Instructions

Conveyor Assembly

Assemble conveyor assembly onto front and rear lift arms using $\frac{3}{4}$ " x 2" bolts, nuts and spacers, see Figure 1.

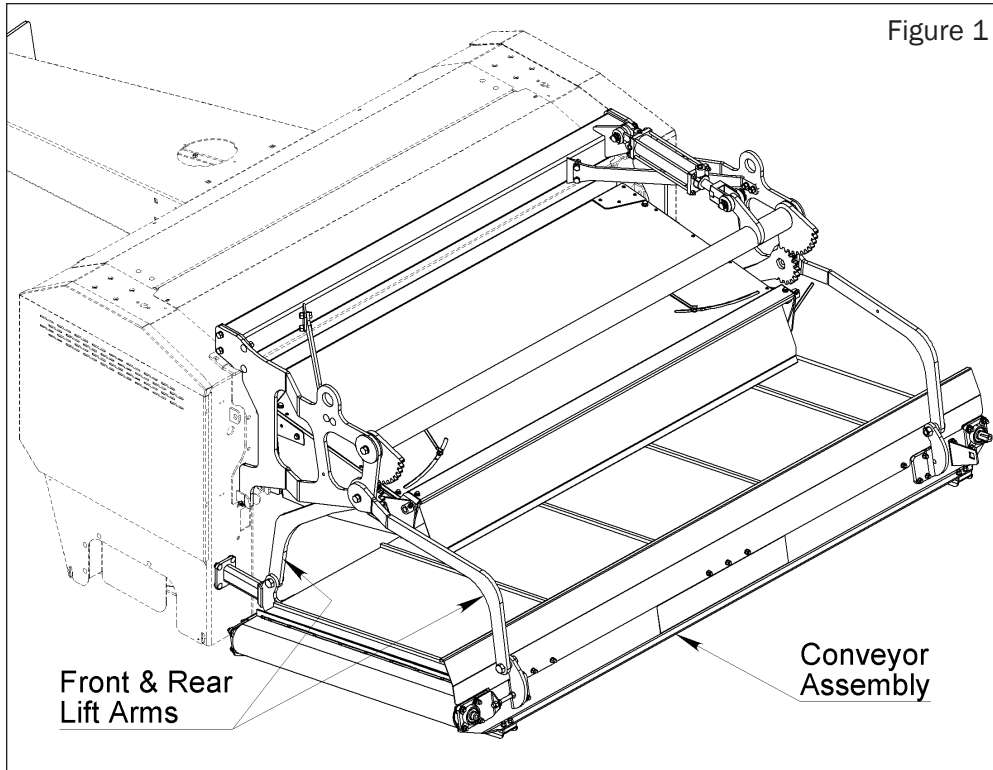

Hydraulic Motor Assembly

1. Install torque plate on hydraulic motor.
2. Install shaft coupler on conveyor roller drive shaft (with 2 set screws at inner end).
3. Install hydraulic motor at outer end of coupler with torque arm in adjacent bracket slot (ensure $\frac{1}{4}$ " x 1" key on roller shaft and $\frac{1}{4}$ " woodruff key on hydraulic motor shaft are in place). Tighten the 3 set screws and jam nuts, see Figure 1.
4. Install motor shaft and coupler safety shield.

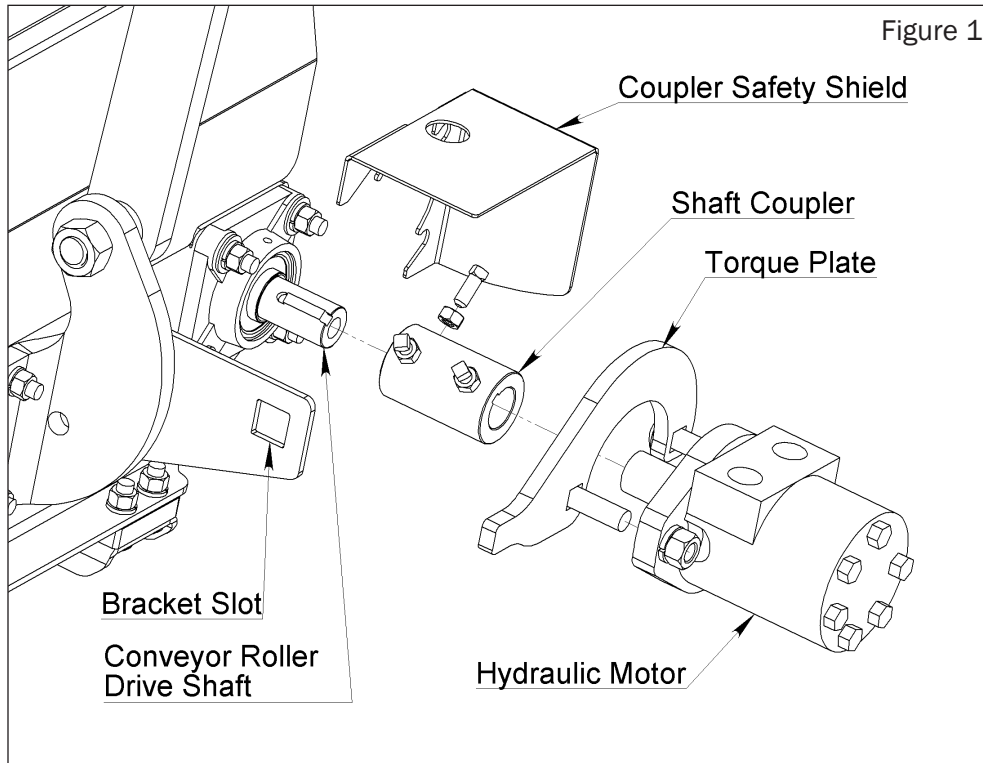

Assembly Instructions

Hydraulic Fittings and Hoses

1. Install hydraulic fittings into motor and cylinder. On the hydraulic cylinder, make sure the restrictor/orifice fittings (2) are installed between the elbow and hose adapter fittings (both inlet and outlet).
2. Install the 4 quick coupler fittings on the 4 hose ends closest to the tractor.
3. Assemble the hoses onto hydraulic fittings at cylinder and motor. The longer 300" hoses attach to the hydraulic motor and the 240" hoses attach to the hydraulic cylinder. Tighten the hose ends at the hydraulic motor. At the cylinder, leave hose connections slightly loose to facilitate bleeding air from the cylinder and the cylinder hoses.

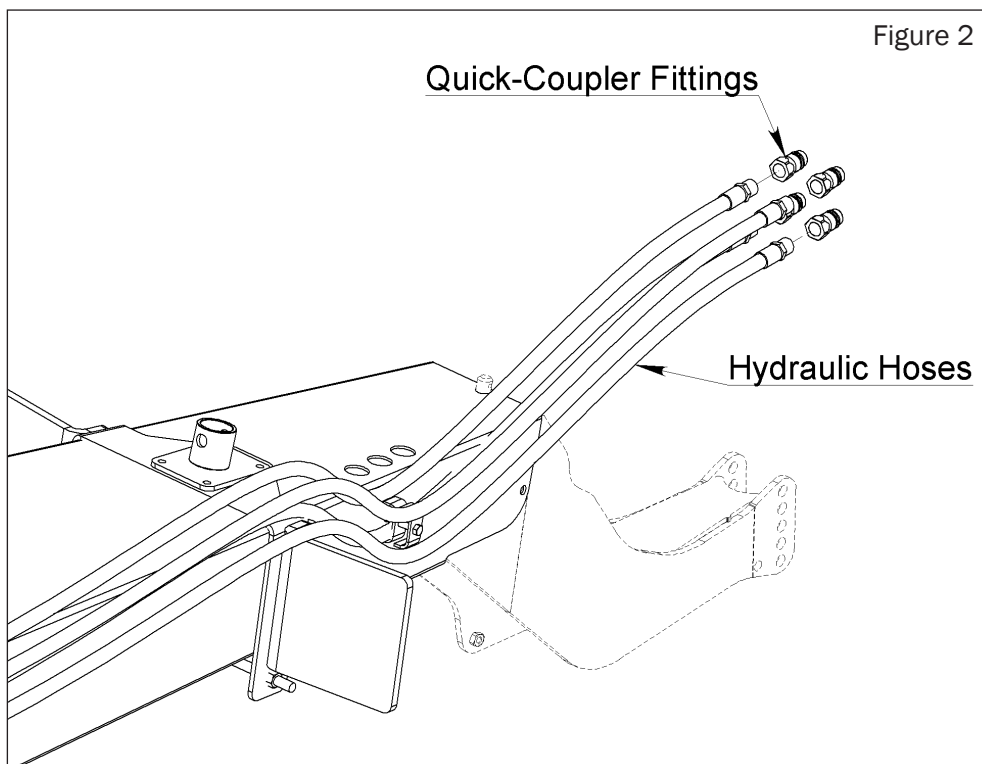
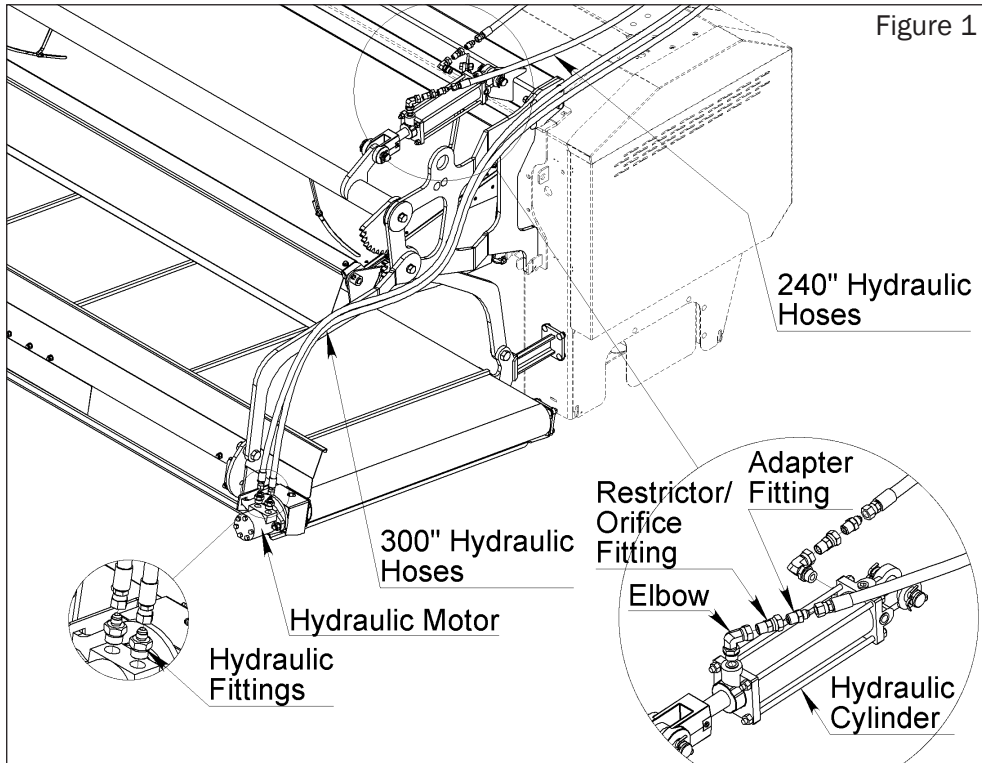

Hydraulic Hose Routing

1. Attach hydraulic motor hoses to right side hook arm frame and right side rear lift arm as shown in Figure 1. Use double clamping with 5/16" bolts (one clamp on top of the other) to space hose clear of the arms.

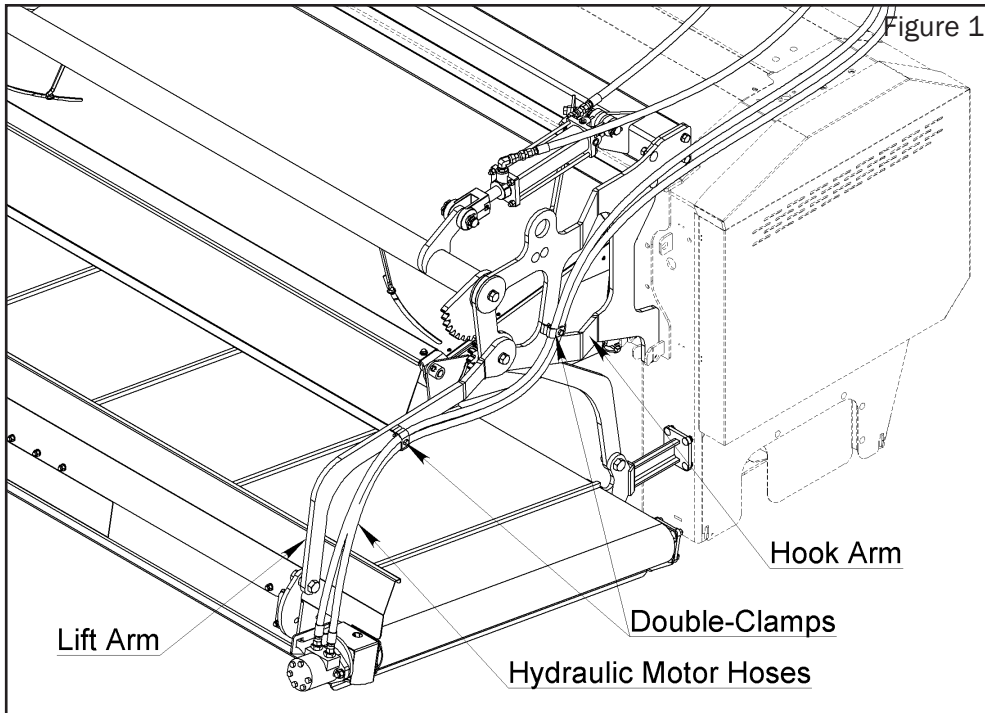

2. On the hitch A-frame, drill 3/8" holes per dimensions in Figure 2. Route the 4 hydraulic hoses as shown and clamp to A-frame surface with 5/16" bolts, washers and nuts.

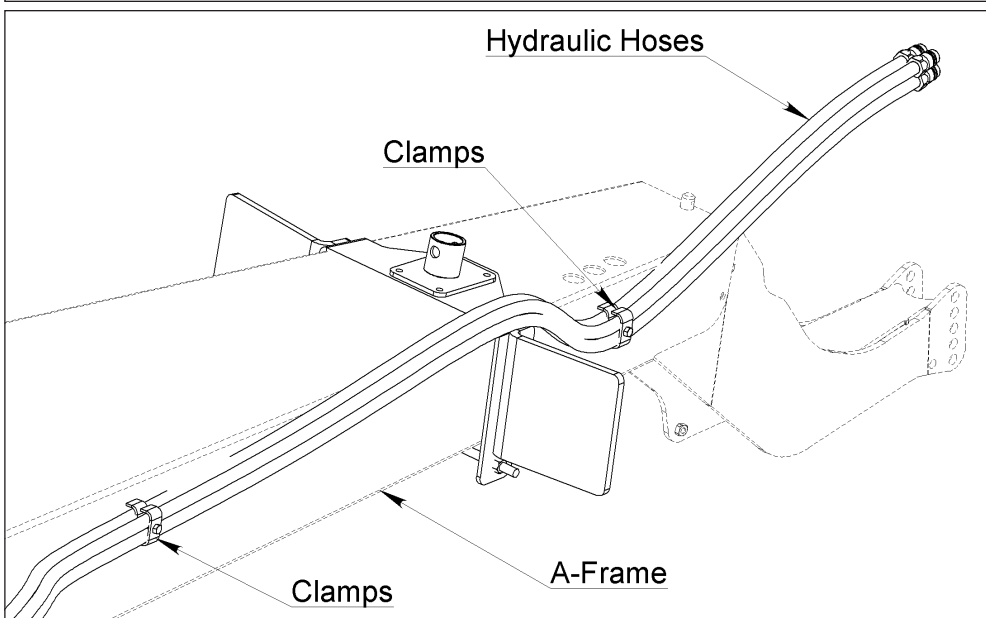
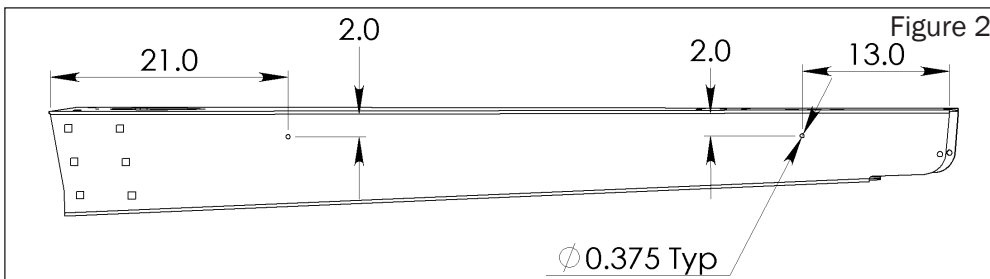

Assembly Instructions

Adjustable Arm Stops

1. Install the 'Clamp On' adjustable arm stops on the left & right hook arms as shown in Figure 1.
2. Set adjustment angle to allow lift arms to rest parallel with the flat surface of the angle bracket as in Figure 1.

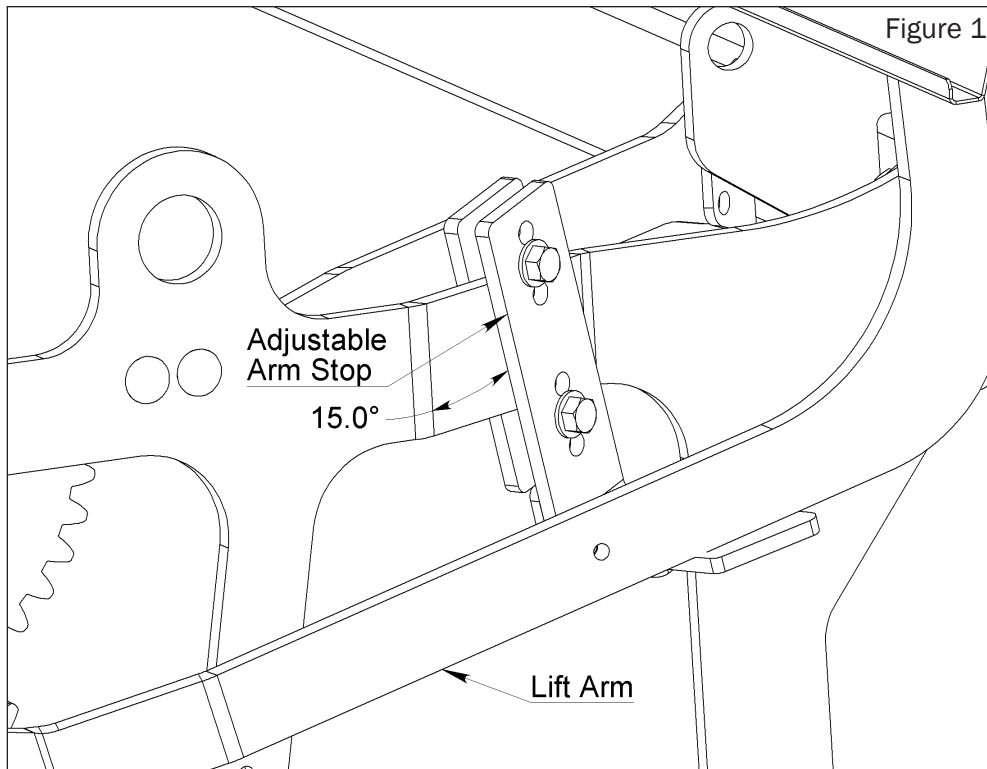

Maintenance

For maintenance on bearings and locking collars, grease/lubrication intervals and torque requirements, refer to the Maintenance section in the 6610 or 6620 Macerator Operator's Manual.

**POWER MERGER 6618
PARTS CATALOGUE**

Conveyor - A66039

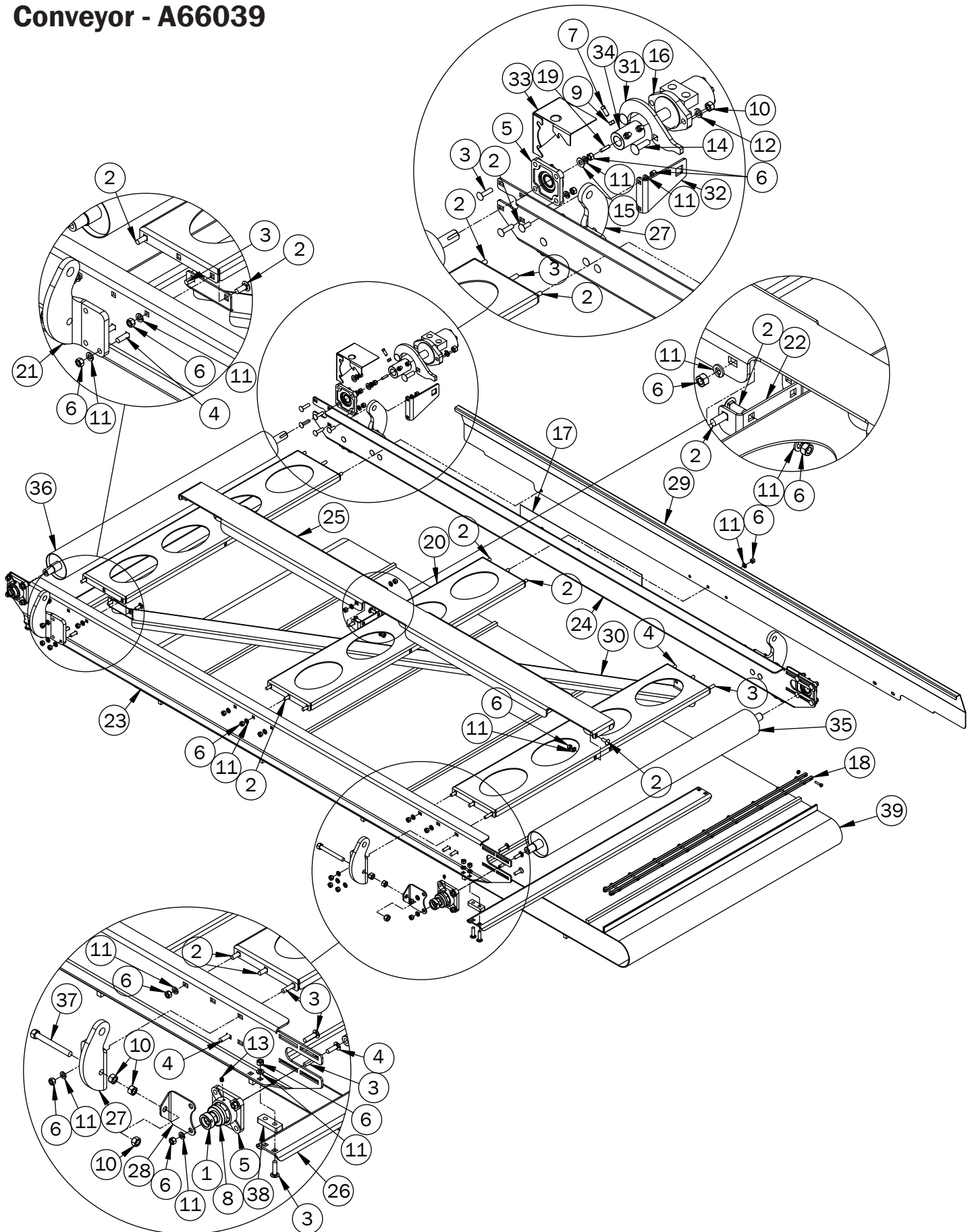

Power Merger 6618 - Parts Catalogue

Conveyor - A66039

Item No.	Stock No.	Drawing No.	Description	Qty.
1	800045	800045	Collar, Locking	2
2	800057	800057	Bolt, Carriage 3/8" x 1"	22
3	800058	800058	Bolt, Carriage 3/8" x 1-1/2"	20
4	800059	800059	Bolt, Carriage 3/8" x 1-1/4"	18
5	800096	800096	Housing, 4 Bolt	4
6	800236	800236	Nut, Standard, 3/8"	60
7	800264	800264	Setscrew, Square Head, 5/16" x 3/4"	3
8	804062	804062	Bearing	4
9	804194	804194	Nut, Standard, 5/16"	3
10	804196	804196	Nut, Standard, 1/2"	8
11	804366	804366	Washer, Lock, Spring, 3/8" Gr. 8	60
12	804367	804367	Washer, Lock, Spring, 1/2" Gr. 8	2
13	807558	807558	Nipple, Grease, 1/4" NF	4
14	807706	807706	Bolt, Carriage 1/2" x 1-3/4"	2
15	807799	807799	Washer, SAE, 7/16"	3
16	808785	808785	Motor, Hydraulic, 2001 DH 50	1
17	814784	814784	Decal, Power Merger 6618, 4" x 24"	1
18	814786	814786	Connector, Belt, Conveyor, Power Merger	1
19	803569	KE1604	Key, 1/4" x 1"	1
20	814645	MC000A	Reinforcement, Conveyor, Power Merger	3
21	814653	MC000B	Bracket, Attach, Conveyor, Power Merger	2
22	814652	MC000C	Bracket, Conveyor, Power Merger	1
23	814651	MC000D	Frame, Conveyor, Power Merger	1
24	814650	MC000E	Frame 2, Conveyor, Power Merger	1
25	814649	MC000F	Brace, Centre, Conveyor, Power Merger	1
26	814648	MC000G	Brace, Bottom, Conveyor, Power Merger	2
27	814646	MC000H	Bracket 2, Attach, Conveyor, Power Merger	2
28	814647	MC000I	Bracket, Tightener, Conveyor, Power Merger	2
29	814640	MC000K	Shield, Conveyor, Power Merger	1
30	814655	MC000M	Brace, Diagonal, Conveyor, Power Merger	1
31	814656	MC001A	Bracket, Motor, Conveyor, Power Merger	1
32	814657	MC001B	Bracket, Swiss, Stop, Conveyor, Power Merger	1
33	814663	MC006	Shield, Motor Shaft, Conveyor, Power Merger	1
34	814588	MC007	Coupler, Conveyor, Power Merger	1
35	814760	MC00W1	Roll, Conveyor, Power Merger	1
36	814761	MC00W4	Roll, Drive, Conveyor, Power Merger	1
37	814635	MC00W9	Threaded Rod, Conveyor, Power Merger	2
38	814689	MC010	Spacer, Bottom Brace, Conveyor, Power Merger	4
39	814603	MC011	Belt, Conveyor, Power Merger	1

Power Merger Kit K108

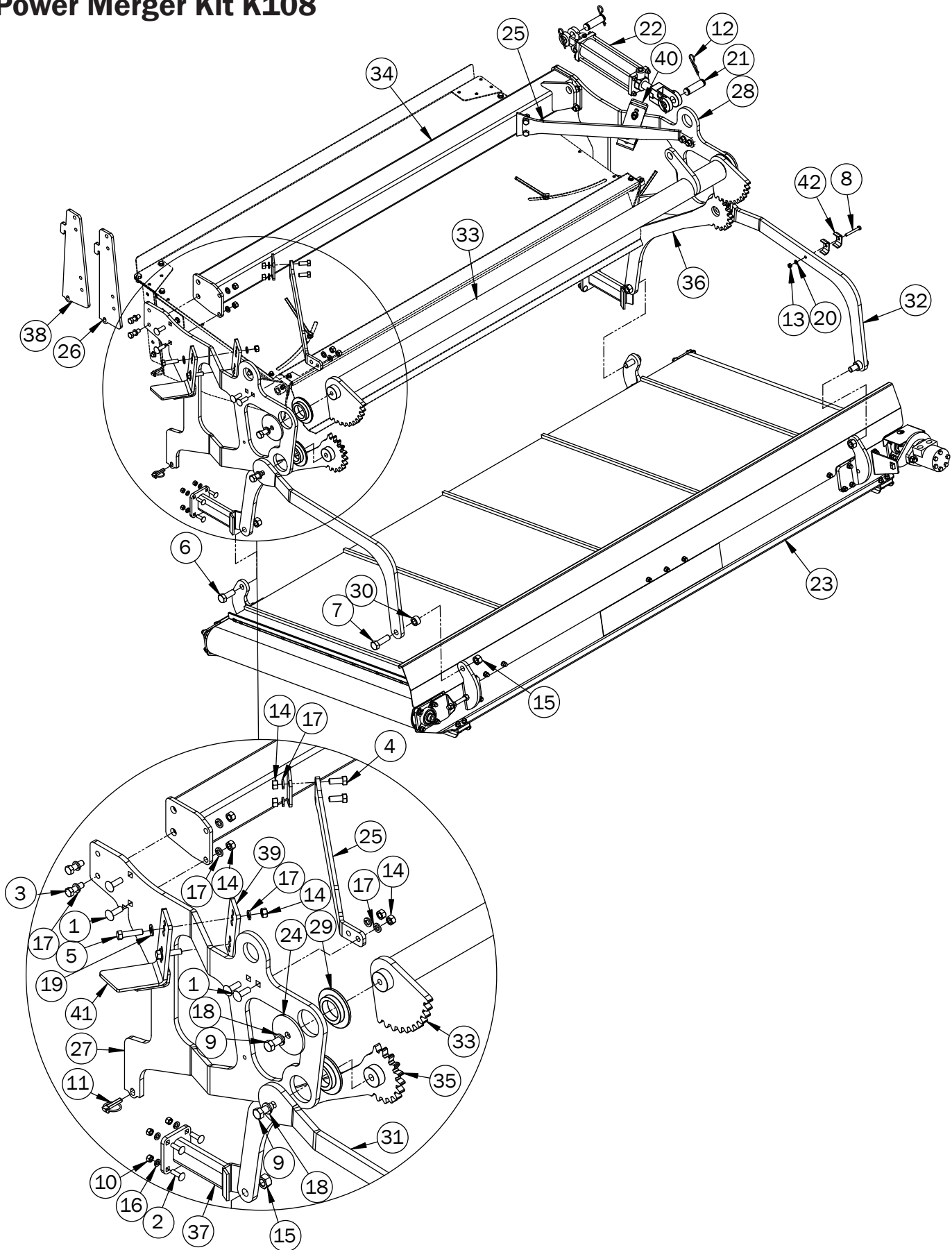

Power Merger 6618 - Parts Catalogue

Power Merger Kit K108

Item No.	Stock No.	Drawing No.	Description	Qty.
1	800054	800054	Bolt, Carriage 1/2" x 1-1/2"	8
2	800059	800059	Bolt, Carriage 3/8" x 1-1/4"	8
3	800165	800165	Bolt, Standard, 1/2" x 1-1/2"	4
4	800166	800166	Bolt, Standard, 1/2" x 1-1/4"	4
5	800168	800168	Bolt, Standard, 1/2" x 2"	4
6	800190	800190	Bolt, Standard, 3/4" x 2"	2
7	800191	800191	Bolt, Standard, 3/4" x 2-1/2"	2
8	800207	800207	Bolt, Standard, 5/16" x 2-1/2"	2
9	800211	800211	Bolt, Standard, 5/8" x 1-1/2"	4
10	800236	800236	Nut, Standard, 3/8"	8
11	801818	801818	Pin, Lynch, 7/16"	2
12	804103	804103	Pin, Hitch, R, 5/32" x 2-15/16"	4
13	804194	804194	Nut, Standard, 5/16"	2
14	804196	804196	Nut, Standard, 1/2"	16
15	804199	804199	Nut, Standard, 3/4"	4
16	804366	804366	Washer, Lock, Spring, 3/8" Gr. 8	8
17	804367	804367	Washer, Lock, Spring, 1/2" Gr. 8	20
18	804368	804368	Washer, Lock, 5/8"	4
19	807524	807524	Washer, SAE, 1/2"	4
20	807528	807528	Washer, Lock, Spring, 5/16" Gr. 8	2
21	809100	809100	Pin, Clevis, 1" x 2.75"	2
22	814220	814220	Cylinder, Hydraulic, 2-1/2" x 8"	1
23	814637	A66039	Conveyor, Power Merger	1
24	814654	MC000L	Washer, Power Merger	2
25	814658	MC003	Brace, Power Merger	2
26	814659	MC004	Hook, Attachment, 7°	2
27	814688	MC0041L	Hook, Attachment, LH, Power Merger	1
28	814687	MC0041R	Hook, Attachment, RH, Power Merger	1
29	814583	MC005B	Spacer, Nylon, Power Merger	4
30	814660	MC005C	Spacer, Power Merger	2
31	814661	MC005L	Arm 2, LH, Power Merger	1
32	814662	MC005R	Arm 2, RH, Power Merger	1
33	814665	MC00W2	Hydraulic Lift, Power Merger	1
34	814666	MC00W3	Main Beam, Power Merger	1
35	814667	MC00W5L	Arm, LH, Power Merger	1
36	814668	MC00W5R	Arm, RH, Power Merger	1
37	814634	MC00W7	Bumper, Power Merger	2
38	814664	MC012	Hook, Attachment, 10°	2
39	814828	MC015	Plate, Stop, Power Merger	2
40	814824	MC01W2	Stop, RH, Power Merger	1
41	814825	MC01W3	Stop, LH, Power Merger	1
42	803829	MC215F	Clamp, Hose, Hydraulic	4

Weight Holder

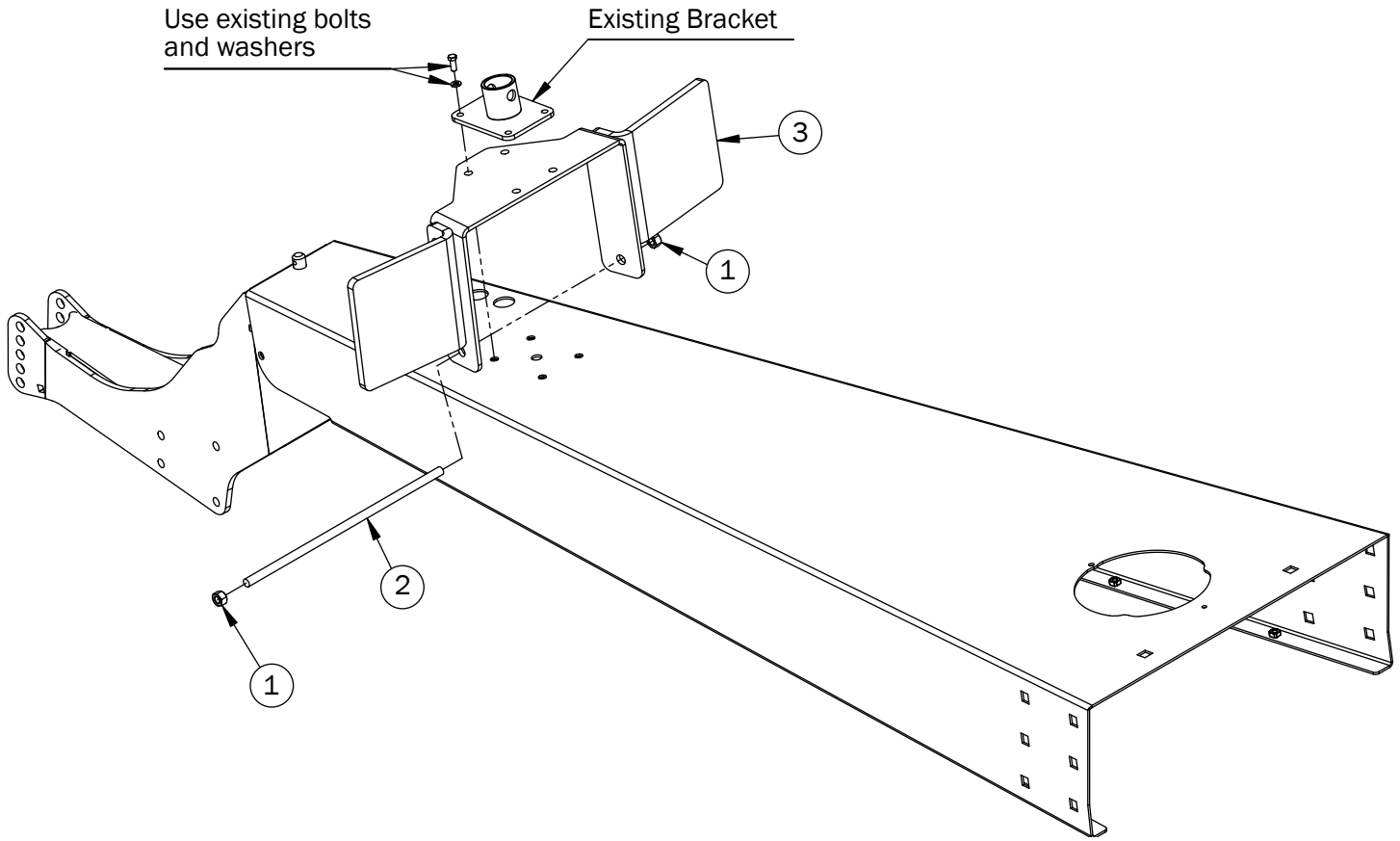

Weight Holder

Item No.	Stock No.	Drawing No.	Description	Qty.
1	804196	804196	Nut, Standard, NC, 1/2"	2
2	814607	MC014	Threaded Rod, Weight Holder, Power Merger	1
3	814636	MC01W1	Weight Holder, Power Merger	1

Hydraulics

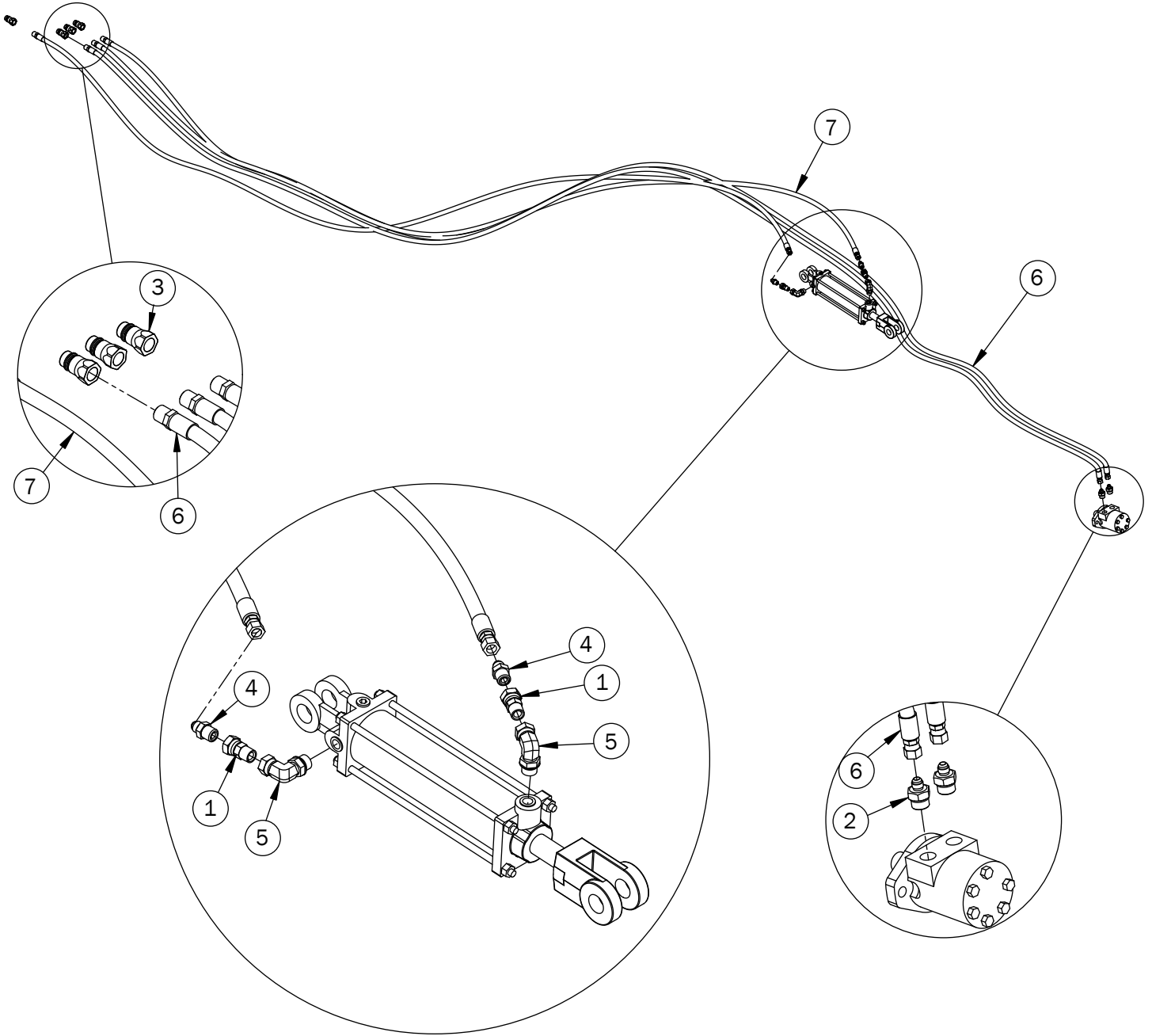

Hydraulics

Item No.	Stock No.	Drawing No.	Description	Qty.
1	808883	79234	Restrictor, Hydraulic, 3/8"	2
2	802486	802486	Adapter, Hydraulic	2
3	804099	804099	Quick Coupler	4
4	814219	814219	Adapter, Hydraulic	2
5	814792	814792	Elbow, Hydraulic	2
6	814592	MC009	Hose, Hydraulic, Power Merger, 300 in.	2
7	807449	MC712A	Hose, Hydraulic, 240 in.	2

LIMITED WARRANTY

AGLAND INDUSTRIES INC. WARRANTY

AgLand Industries Inc. (hereinafter called "AgLand"), as the Manufacturer, warrants to the original owner of the AgLand Power Merger (hereinafter called the "Power Merger") the following:

A one (1) year* warranty that the purchased Power Merger will be free of defects in material or workmanship and workmanship on all parts manufactured by AgLand, including AgLand manufactured owner-serviceable parts (provided such parts are serviced in accordance with the Operator's Manual), from the date of delivery to the original retail purchaser under normal farm use and service, excluding normal wear items such as (but not limited to) belts, pickup tines, tires, and exterior finish.

*Three (3) months after delivery when purchased by a commercial operator.

The sole obligation of the Manufacturer is limited to repairing or replacing, as the Manufacturer may elect, any part or parts that prove, in the Manufacturer's judgement, to be defective in material or workmanship.

Warranty service may only be performed by an authorized AgLand Dealer or an authorized AgLand Service Centre or as determined by AgLand.

Defective parts must be returned to the Manufacturer or the AgLand Dealer who sold the Power Merger at the expense of the retail purchaser and are to be inspected by the Manufacturer prior to any warranty work being approved. The AgLand Dealer will forward, at the retail purchaser's expense, any defective parts to AgLand with a written request of warranty work required.

Note: All parts NOT manufactured by AgLand carry their own manufacturer's warranty. The customer is responsible for all costs necessary to replace those parts unless covered by the applicable manufacturer.

The above warranty is based on the following factors:

AgLand reserves the right to repair or replace, at its discretion, any defective part in whole or in part.

All instructions in the AgLand Power Merger Operator's Manual must be followed.

The Warranty Registration must be forwarded to AgLand within thirty (30) days of the date of delivery of the Power Merger to the Retail Purchaser to validate the warranty.

All warranties are subject to legislation of the state or province in which the Power Merger is sold.

AgLand will not be responsible or liable for any of the following:

a) The return of any part or parts, or the Power Merger as a whole, to the selling AgLand Dealer or to the Manufacturer, neither AgLand or its authorized AgLand Dealer are responsible for the cost of shipping, transport, freight, labour, or any cost other than the warranted replacement part itself; b) The care, maintenance and safe operation of the Power Merger, which is the responsibility of the owner of the Power Merger; c) Any accidents, injury, damage or loss incurred due to use by any operator of the Power Merger; d) Any accidents, injury, damage or loss incurred due to faulty use, repair, operation or maintenance of the Power Merger; e) Any cost incurred for replacing or repairing of parts not manufactured by AgLand which carry their own manufacturer's warranty; f) Any out-of-pocket expenses or loss of revenue as a result of any defect in material or workmanship of any part or parts, or the Power Merger as a whole; g) Damages, malfunctions or failures resulting from the use of any attachment not authorized by AgLand; h) Any accidents, injury, damages, or loss incurred due to any safety shields, lights, reflectors, decals, emblems, etc., being removed or covered; i) Any accidents, injury, damage or

loss during transport due to the improper, or lack of, use of the safety tow chain or transport lock pin of the Macerator the Power Merger is attached to; j) Any accidents, injury, damage or loss due to the lack of safety precautions when performing routine maintenance; k) Damages, malfunctions or failures caused by force majeure, abuse, accident, fire, or acts of God; l) All customers outside of North America are responsible for compliance with local laws, codes and regulations regarding operating requirements and certification, as well as all costs associated with such requirements and certification.

Any available warranty will be void if: a) Annual maintenance procedures are not followed as per the Operator's Manual; b) Any altering or modification is performed on the Power Merger which is not approved by the Manufacturer; c) Any additional equipment is installed on the Power Merger which has not been approved by the Manufacturer; d) Any instruction given in the Operator's Manual which has not been followed including during set up or assembly or regular maintenance; or e) Any claim made under this warranty by, or for, a person other than the original owner.

There are no other warranties, expressed or implied, by AgLand or its Authorized AgLand Power Merger Dealers regarding the AgLand Power Merger except the warranty expressed herein. ANY IMPLIED WARRANTIES, INCLUDING MERCHANTABILITY, OR FITNESS FOR A PARTICULAR PURPOSE, SHALL NOT EXTEND BEYOND THE APPLICABLE WARRANTY PERIODS SPECIFIED ABOVE. AGLAND'S SOLE LIABILITY, WITH RESPECT TO ANY DEFECT, SHALL BE AS SET FORTH IN THIS LIMITED WARRANTY, AND ANY CLAIMS FOR INCIDENTAL OR CONSEQUENTIAL DAMAGES ARE EXCLUDED.

No person is authorized to bind AgLand to any other warranty whatsoever.

AgLand reserves the right at any time to make changes or improvements to the design, materials, or specifications of the Power Merger or parts without thereby becoming liable to make similar changes to the Power Merger or any of its parts previously manufactured.

Manufactured by:

AgLand Industries Inc.

