

Manufacturing Company, Inc.

CT10M-F

SERIAL# _____

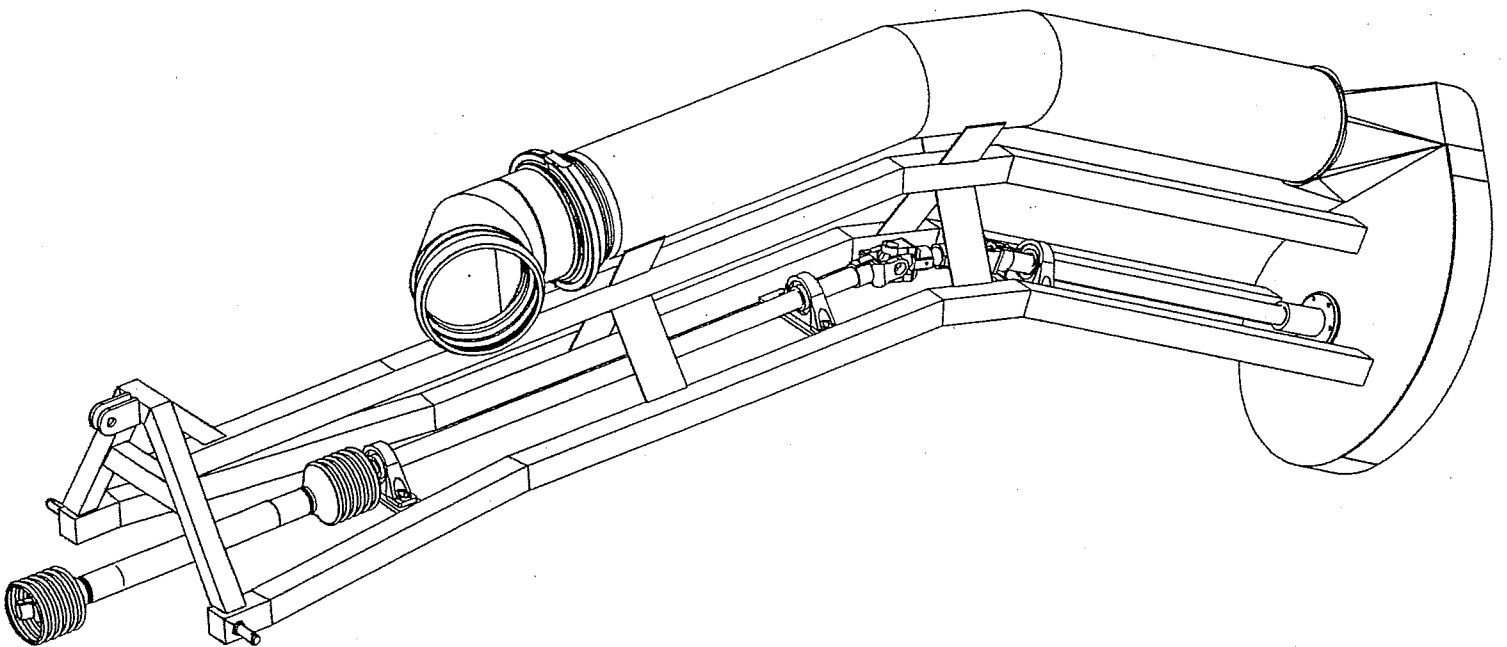

CT10M-F			
REF#	DESCRIPTION	QTY	PART NUMBER
1	Frame, CT10M	1	MPU002618
2	Elbow 10" 45 Deg.	1	MFP01397
3	Lock, 10" Circle Ring	1	5PMP2123-04
4	Gasket, Rubber	1	5PMP1624-01
5	Impeller, 17"	1	MFP06036
6	Strainer, CT10M Pump	1	MPU002560
7	Plate, Outer Strainer Intake	1	MPU002500
8	Shaft, Rear 1-1/2"x4'-1-3/4"	1	MPU002616
9	Assembly, Double Joint	1	PUJ01966
10	Shaft, Front 1-1/2"x 5'-6"	1	MPU002617
11	Bearing, 1-1/2"	3	5BRGUCPL208-24
12	Holder, Flanged Marine Bearing	1	MFG002586
13	Bearing 1-1/2"x2"x6" Marine	1	5BRG1 1/2x2x6
14	Nut 1-1/4" LH	1	5NUT1 1/4-10LHBRZ
15	Key, Shaft	3	MFP02998
16	PTO, 1-1/2"x 1-3/8 (6) 2500		5UJT392687
16	PTO, 1-1/2"x 1-3/8 (6) 44		5UJT14004424

CT10M-F

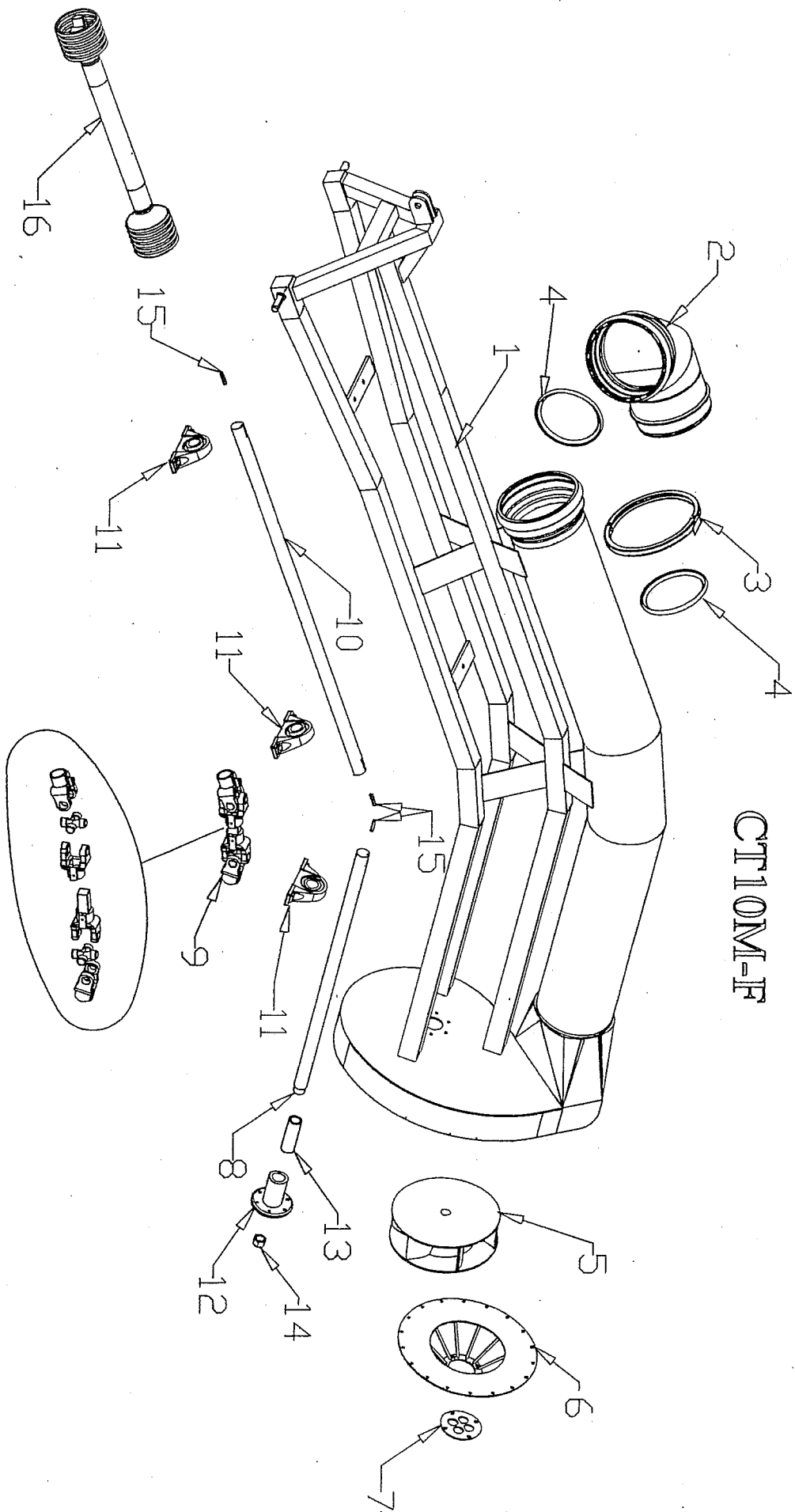

PUJ01966			
9A	Yoke / W Shaft	1	PUJ02004
9B	Yoke	2	5UJT34400183
9C	Universal Joint	2	5UJTHM431
9D	Yoke	1	5UJT177-4400

MPU02016

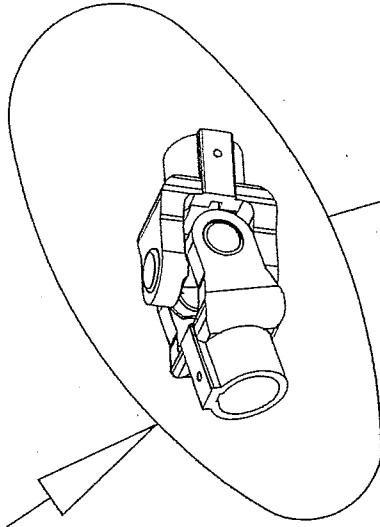

MPU02017

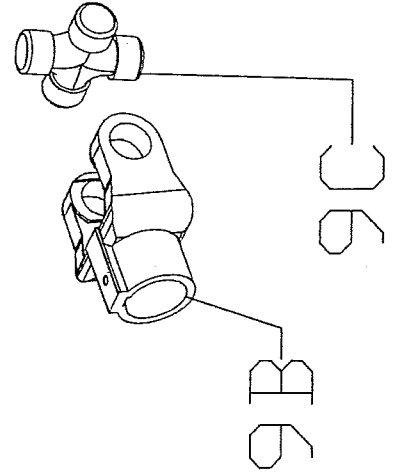
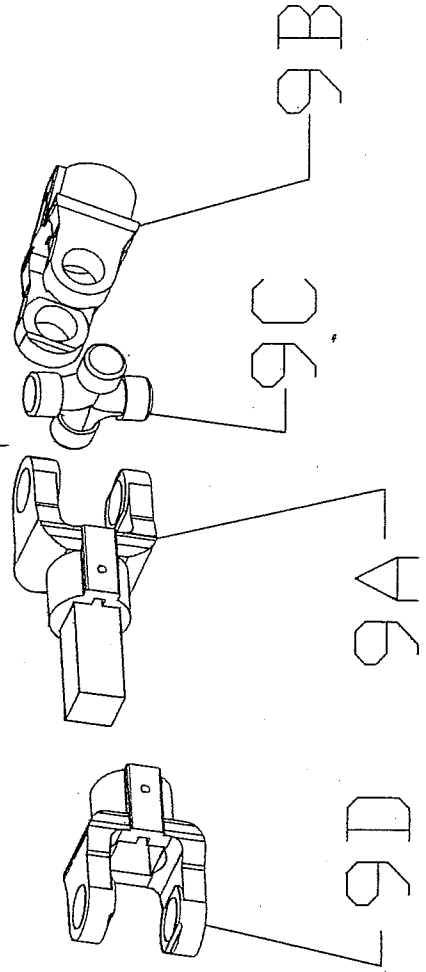
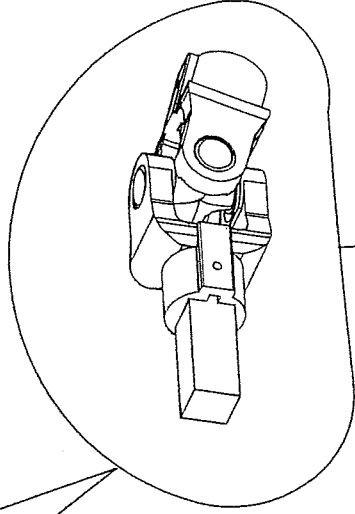

CT10M			
REF#	DESCRIPTION	QTY	PART NUMBER
12	Holder, Flanged Marine Bearing	1	MPU002587
12A	Bolt, 3/8"x 1-1/2" Plow	24	5BLTPL38112Z
12B	Washer 3/8" Flat	24	5WSHFLT38S
12C	Washer, 3/8" Lock	24	5WSHLOCK38S
12D	Nut, 3/8" Brs	24	5NUT38HXBRS

