

-  Tillage
-  Haulage
-  Landscaping
-  Seeding & Plantation
-  Crop Protection
-  Harvest
-  Post Harvest

*Solutions...*



## BERI UDYOG PVT LTD

Corporate Office:

Plot No. 235 to 240, Sec-3, HSIIDC, Karnal- 132001 (Haryana), India

+91 184 2221571/ 72/ 73    info@fieldking.com, www.fieldking.com



## Multi Row / Double Coil Cultivator / Tiller



➤ Operator Manual ➤ Service Manual ➤ Part Catalogue

# CONGRATULATIONS!

You have invested in one of the best implements of its type in the market today.

The care you give your "FIELDKING" implement will greatly determine your satisfaction with its performance and its service life. A careful study of this manual will give you a thorough understanding of your new implement before operating.

If your manual is lost or destroyed, "FIELDKING" will be glad to provide you a new copy. Visit to nearest dealership & get a copy. Most of our manuals can also be downloaded from our website at [www.fieldking.com](http://www.fieldking.com).

As an authorized "FIELDKING" dealer, we stock genuine "FIELDKING" parts which are manufactured with the same precision and skill as our original equipment. Our trained service persons are well informed on methods required to service "FIELDKING" equipments and are ready to help you.

Should you require additional information or assistance, please contact us.

YOUR AUTHORIZED

FIELDKING DEALER

BECAUSE "FIELDKING" MAINTAINS AN ONGOING PROGRAMME OF PRODUCT IMPROVEMENT, WE RESERVE THE RIGHT TO MAKE IMPROVEMENTS IN DESIGN OR CHANGES IN SPECIFICATION WITHOUT INCURRING ANY OBLIGATION TO INSTALL THEM ON UNITS PREVIOUSLY SOLD. BECAUSE OF THE POSSIBILITY THAT SOME PHOTOGRAPHS IN THIS MANUAL WERE TAKEN OF PROTOTYPE MODELS, PRODUCTION MODELS MAY VARY IN SOME DETAIL. IN ADDITION, SOME PHOTOGRAPHS MAY SHOW SHIELDS REMOVED FOR THE PURPOSE OF CLARITY. NEVER OPERATE THIS IMPLEMENT WITHOUT ALL SHIELDS IN PLACE.

## TO THE PURCHASER

This manual contains valuable information about your new "FIELDKING" double coil cultivator/tiller. It has been carefully prepared to give you helpful suggestions for operating, adjusting, servicing and ordering spare parts.

Keep this manual in a convenient place for quick and easy reference. Study it carefully. You have purchased a dependable and sturdy double coil cultivator/tiller but only by proper care and operation can you expect to receive the service and long life designed and built into it.

Sometime in the future your double coil cultivator/tiller may need new parts to replace which are worn out or broken. If so, go to your dealer and provide him equipment's detail like model and part number.

### CUSTOMER INFORMATION

Name \_\_\_\_\_

Purchased From \_\_\_\_\_

Date of Purchase \_\_\_\_\_

Model No. \_\_\_\_\_

Serial No. \_\_\_\_\_

## PURCHASER / OPERATOR'S RESPONSIBILITY

1. Read and understand the information contained in this manual.
2. Operate, lubricate, assemble and maintain the equipment in accordance with all instructions and safety procedures in this manual.
3. Inspect the equipment and replace or repair any parts that are damaged or worn out which under continued operation would cause damage, wear to other parts, or cause a safety hazard.
4. Return the equipment or parts to the authorized "FIELDKING" dealer from where it was purchased for service or replacement of defective parts that are covered by warranty. (The "FIELDKING" Factory may inspect equipment or parts before warranty claims are honored.)
5. All costs incurred by the dealer for traveling to or transporting the equipment for warranty inspection and claims will be borne by the customer.

# INDEX

## **1. TECHNICAL DATA**

- 1.1 Introduction
- 1.2 Warranty
- 1.3 When the warranty becomes void
- 1.4 Warning

## **2. USAGE INSTRUCTIONS**

- 2.1 Before use & adjustments
- 2.2 Attaching cultivator/tiller to the tractor
- 2.3 Safety

## **3. MAINTENANCE**

- 3.1 Operation, care & maintenance of cultivator/tiller
- 3.2 Storage of machine after work

## **4. PARTS CATALOGUE**

# 1. TECHNICAL DATA

## 1.1 INTRODUCTION

Double coil tyne tiller/cultivator are eminently suitable for use in stone and root obstructed Soil. When one tyne strikes a hidden object, too firmly fixed to be moved, the others continue to work at the correct depth. Tillers may be used for loosening and aerating soil to a depth of nine inches preparing seedbeds quickly and economically.

“FIELDKING” double coil tyne tiller/cultivator is designed for tougher operations. It is suitable for varying soil conditions. The spring steel tyne is designed in such a manner that it doesn't need any separate spring. The coil shape tynes get its strength because of efficient design wherein, the stress prone areas are so well shaped that it withstands any distorting forces.

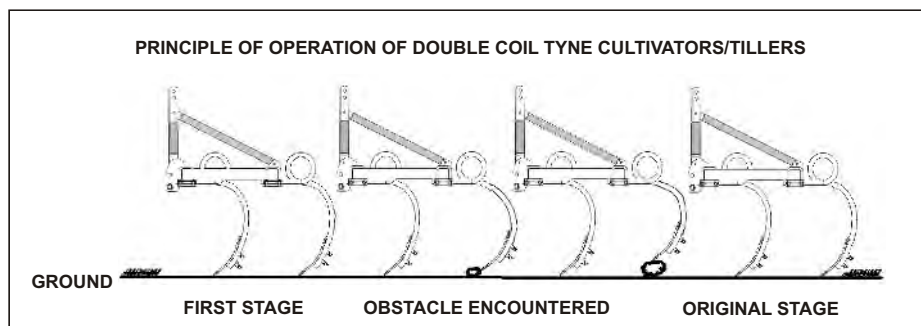

## 1.2 WARRANTY POLICY FOR FIELDKING TILLER/CULTIVATOR

1. Beri Udyog Pvt. Ltd. (“ the company”) warrants to the retail purchase of the “FIELDKING” tiller/ cultivator that subject to the limitation specified here in below, the company’s authorised dealer will repair or replace any part there of found. In its opinion, to be defective in materials of workmanship. The warranty shall be for a period 1 year from the date of purchase of new “FIELDKING” agriculture tiller/cultivator by the original purchaser (“retail purchaser”).
2. This warranty is limited to the delivery to the retail purchaser, free at the authorized dealer’s workshop or company’s works of the part or parts whether repaired or replaced in exchange for those acknowledge by the company to be defective.
3. The purchaser of “FIELDKING” agriculture tiller/cultivator are advised strictly to follow the instructions given in the operator manual, provided by the company along with the “FIELDKING” tiller/cultivator at the time of delivery, changes if any in the “FIELDKING” tiller/cultivator, resulting in improper usage will not be covered in the warranty, This warrant will

automatically get terminated on the expiry of warrant period even in the “FIELDKING” tiller/cultivator, may not in use for any time during the warranty period for any reason whatsoever including any technical reasons, any time for such repairs/replacements of parts and in transit, whether under this warranty or otherwise shall not be excluded from the warranty period.

4. Warranty shall apply to following:

- Manufacturing defects: Breaking of any structure & fabrication covered under warranty.

5. Warranty shall not apply to the following:

- Accidental cases are not covered under warranty.

**NOTE:** If any kind of breakage and damage is found due to poor handling of customer that also is not covered under warranty policy.

6. The retail purchaser shall be required to make a thorough examination of the products prior to the purchase. The authorized dealer are in no way the legal agent of the company and have no right or authority to give any warranty or assume any obligation on behalf of the company or bind the company in any manner whatsoever.

7. For the purpose of this warranty, the term “product” means and includes only new “FIELDKING” tiller/cultivator, manufactured by or for the company design sold and installed by the authorized dealer.

8. The company’s responsibility is limited to the terms of this warranty and it shall not be liable for personal injuries or consequential or resulting liability, damage or loss arising from any defect.

9. The company’s liability under this warranty is depended upon the strict observance by the retail purchase, of the following provisions.

- The retail purchaser at the time of delivery shall sign complete and return the authorized warranty and dealer’s delivery report.

- All the parameters should be thoroughly checked as per the scheduled maintenance in the operator’s manual. The customers are also bound to use the genuine spares for “FIELDKING” tiller/cultivator, purchased from authorized “FIELDKING” dealers.



- Repairs and replacements will be performed by the facility of the authorized dealers/its branch dealers.
  - This warranty shall not apply if the product or any part there of repaired or altered not in accordance with our standard repair procedure or by any person other than an authorized dealers/its branch dealers/its authorized service centre.
  - The decision of the company or the concerned authorized dealers in regard to the warranty shall be final and conclusive and the retail purchaser hereby agrees to unconditionally accept their decision on all.
  - This warranty does not cover any applicable taxes payable on any parts which the company may supply or repairs free of cost of during the warranty period. This warranty also does not cover the cost of packaging to and fro freight and transportation charges etc. on the defective "FIELDKING" tiller/cultivator or other part of the "FIELDKING" tiller/cultivator sent to "FIELDKING" dealers locations.
  - Claims arising from this warranty will be considered only if they are notified in writing to the concerned authorized dealers after the defect has been ascertained.
  - The company reserves the right to make changes in design or introduce any improvement or add any parts on the products any time without incurring any obligation to install the same on products previously sold.
10. This contract will be ineffective and incorporative if:
- The duly warranty card is not presented during the repairs.
  - The "FIELDKING" agriculture tiller/cultivator or any parts thereof is subjected to neglect, fire, floods or other acts of god or in the company's opinion any damage has caused to be "FIELDKING" agriculture tiller/cultivator during transportation.
  - The original numbers are removed, obliterated or altered from the unit.
  - Any attempt is made to have the repairs executed by a person, other than the company's or its authorized representatives.
  - Any defect if not informed immediately to the company or its authorized representative, any alterations in the warranty card is made.
  - The use of replacement parts not manufactured or supplied by the company will automatically invalidate this warranty.

This warranty shall not be apply to defect/damages caused by the normal wear and tear, accident, transportation, misuse or neglect usage in non agri applications, defect in the products which have been altered outside the company's work or which have been let out in hire or the identification marks in which have been altered or removed. Company's decisions in this respect will be final and binding on all.

11. The above warranty is in lieu of all other warranties express or implied, and no person, agent or representative of the Company is authorized to give any other warranties on the company's behalf or the assume for it any other liability in connection, with the product.
12. The court at Karnal shall have exclusive jurisdiction to try, entertain and dispose of all proceeding relating to any dispute arising between the company and the retail purchaser on the liability of the company under this warranty.

### 1.3 WHEN THE WARRANTY BECOMES VOID

1. Besides the caused specified in the supply agreement, the warranty shall in any case become void.
2. Should there have been a maneuver error.
3. When following repairs made by the customer without authorization from the manufacture or owing to the installation of spurious spare parts, the machine is subject to variations and the damage can be ascribed to these variations.
4. When the user failed to comply with the instructions in the operator's handbook.
5. When the implement has been used beyond the specified power limit like (tractor horse power).
6. No warranty will be given if the service is not done on time.

### 1.4 WARNING

Thoroughly read the instruction manual before proceeding with the various operations.  
Maintain the cultivator as per the instructions of this handbook to be entitled for warranty.

## 2. USAGE INSTRUCTIONS

### 2.1 BEFORE USE & ADJUSTMENTS

Before mounting of cultivator make sure that all nuts & bolts are properly secured. Also determine soil and trash conditions of the field and make the preliminary adjustments. e.g.

#### Tyne leveling

To eliminate uneven working and side draft, leveling is done by means of top link.

#### Depth control

The depth at which the implement is required to work is controlled hydraulically by raising or lowering the control lever on the tractor.

### 2.2 ATTACHING THE CULTIVATOR/TILLER TO THE TRACTOR

1. Place the cultivator duly leveled on the flat piece of land.
2. Reverse the tractor to the cultivator ( Do not drag the cultivator/tiller up the tractor)
3. Attach the left arm of the tractor to the cultivator/tiller first.
4. Attach the central arm to the cultivator/tiller. To attach, turn the screws on both sides to an equal length. If the arm is too short or too long, turn the screw to adjust both at the same time until aligned with the hole on the central arm.
5. Attach the lower right arm, turn the screw until the mounting pin is at the same level as the hole on the tractor arm. If the gap between the hole and mounting pin is too close or too distant, turn the control arm in or pull it away to an appropriate distance. You may have to adjust both height and distance at the same time. When the hole at tractor arm and mounting pin are even, insert the pin in the hole and lock it with the lynch pin.
6. After attaching the cultivator/tiller, lift it and adjust the control arm parallel to the ground. When you look from both rear or sideways, all shovel should be touching the ground uniformly.

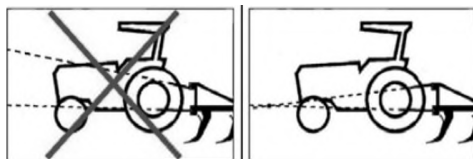

#### **Danger:**

In operating position the top link must be higher on the machine side than on the tractor side!

## 2.3 SAFETY



### REMEMBER SAFETY FIRST

Operator must read the instruction manual before operating the cultivator. Do not allow anyone to operate this equipment who has not fully read and comprehended this manual and who has not been properly trained in the safe operation of the equipment.

### SAFETY INSTRUCTIONS

1. All equipment is potentially hazardous. There is no substitute for a safety conscious operator who recognizes potential hazards and follows reasonable safety practices.
2. Personal protection equipment including safety glasses, safety shoes, and gloves are recommended during assembly, installation, operation, adjustment, maintaining, repairing, removal or moving the implement.
3. Never place yourself between the tractor and implement while implement is in operation.
4. Do not work under a raised implement unless it is securely blocked or held in position. Do not depend on the tractor hydraulic system to hold the implement in place.
5. A heavy load can cause instability of the tractor. Use extreme care during travel. Slow down on turns and watch out for bumps. The tractor may need front counterweights to counter-balance the weight of the implement.
6. Do not allow others to ride on the tractor with an operator. Riders are subject to injury such as being struck by foreign objects or being thrown off. Riders obstruct the operator's view resulting in unsafe operation. Never allow anyone to ride on the implement!
7. Do not allow anyone who is not familiar with the safety rules and operation instructions to use this implement.
8. Keep alert and watch the front as well as the rear when working with equipment.
9. Always be sure the implement is in the fully raised position when in transport.
10. When removing or adjusting equipment, be sure that your feet are never under the implement.
11. Avoid excessive speed during operation.
12. Before you operate the field cultivator, check over all pins, bolts and connections to be sure that all are securely in place. Replace any damaged or worn parts immediately.
13. Make implement adjustments only when the implement is attached to the tractor.
14. Watch for and avoid hidden obstructions, i.e. buried pipes, rocks, uneven concrete slabs, stumps etc., when operating equipment.

15. Never operate tractor and implement under trees with low hanging limbs. Operators can be knocked off the tractor and then run over by the implement.
16. Operating spring loaded cultivator shanks may suddenly fling rocks and clods. Keep all bystanders 10 meter away and operator must wear safety glasses.
17. Reduce speed when transporting mounted implements to avoid bouncing and momentary loss of steering control.
18. It may be necessary to raise implement slightly and then lower to desired working depth when tractor is moving.
19. Use extra care when working on slopes.
20. Never use alcoholic beverages or drugs which can hinder alertness or coordination while operating this equipment. Consult your doctor about operating this machine while taking prescription medications.



**ATTENTION**

Non-observance of the above rules shall be considered negligence. It will rule out any liability of the manufacturer for all possible damage and / or consequences.  
The user is solely responsible for any risk!

### **3. MAINTENANCE**

#### **3.1 OPERATION, CARE & MAINTENANCE OF TILLER/CULTIVATOR**

1. All the shovels of the tynes should be set at equal depth. To do this, place the cultivator on level ground and see that all the shovel touch the ground.
2. Before commencing work with a cultivator, check it for loose bolts and nuts and fasten them properly. After having taken all these precautions, run the cultivator for one hour and then inspect it once more for any loose parts.
3. Never turn or reverse your tractor while cultivator is ploughed deep in field. This will twist the assemblies out of alignment and damage them extensively.
4. Reverse or replace the shovel point when worn out. Delay may result in wearing out of the tynes which will result into expensive repairing/replacements. Avoid use of extra wide shovels as they do not improve tillage quality but only put extra load on the tractor and also result into extra fuel consumption.

#### **3.2. STORAGE OF CULTIVATOR/TILLER AFTER WORK**

1. Wash the cultivator after work.
2. Replace the worn out nuts & bolts.

3. If cultivator has to remain unused for long time then clean it & apply a layer of used oil for rust prevention.
4. These steps will enhance the life of your cultivator.



## PARTS CATALOGUE

SR.NO.	PARTS DESCRIPTION	PART CODE			QTY		
		9 TYNE	11 TYNE	13 TYNE	9	11	13
1	BOX FRAME ASSEMBLY	FKDCT-5001	FKDCT-5005	FKDCT-5008	1	1	1
2	FRONT TOP LINK-65X16X724	FKDCT-007			1	1	1
3	REAR TOP LINK-50X16X961	FKDCT-008			1	1	1
4	TYNE	25 MM	30 MM	35 MM	9	11	13
		10330033	FKDCT-016	FKDCT-014			
5	U-CLAMP BRACKET	FKDCT-019	FKDCT-013	FKDCT020	9	11	13
6	U-CLAMP	FKDCT-009			18	22	26
7	SHOVEL	FKRMD-07	10320010		9	11	13
8	HITCH PIN 25.4X284MM	10020007			2		
9	HITCH PIN WASHER	10270007			2		
10	HITCH PIN NUT	10280008			2		
11	HEX HEAD BOLT 18X75X2.5MM	10260036			2		
12	SPRING WASHER 18MM	10270006			2		
13	NYLOCK NUT M18X2.5MM	10280020			2		
14	HEX HEAD BOLT M16X110X2MM	10260022			1		
15	SPRING WASHER 16MM	10270005			2		
16	NYLOCK NUT M16X2MM	10280005			2		
17	HEX HEAD BOLT M16X75X2MM	10260018			1		
18	ROUND HEAD BOLT 7/16X2.5 INCH	10260137			18	22	26
19	MS NUT 7/16 BSW	10280033			18	22	26

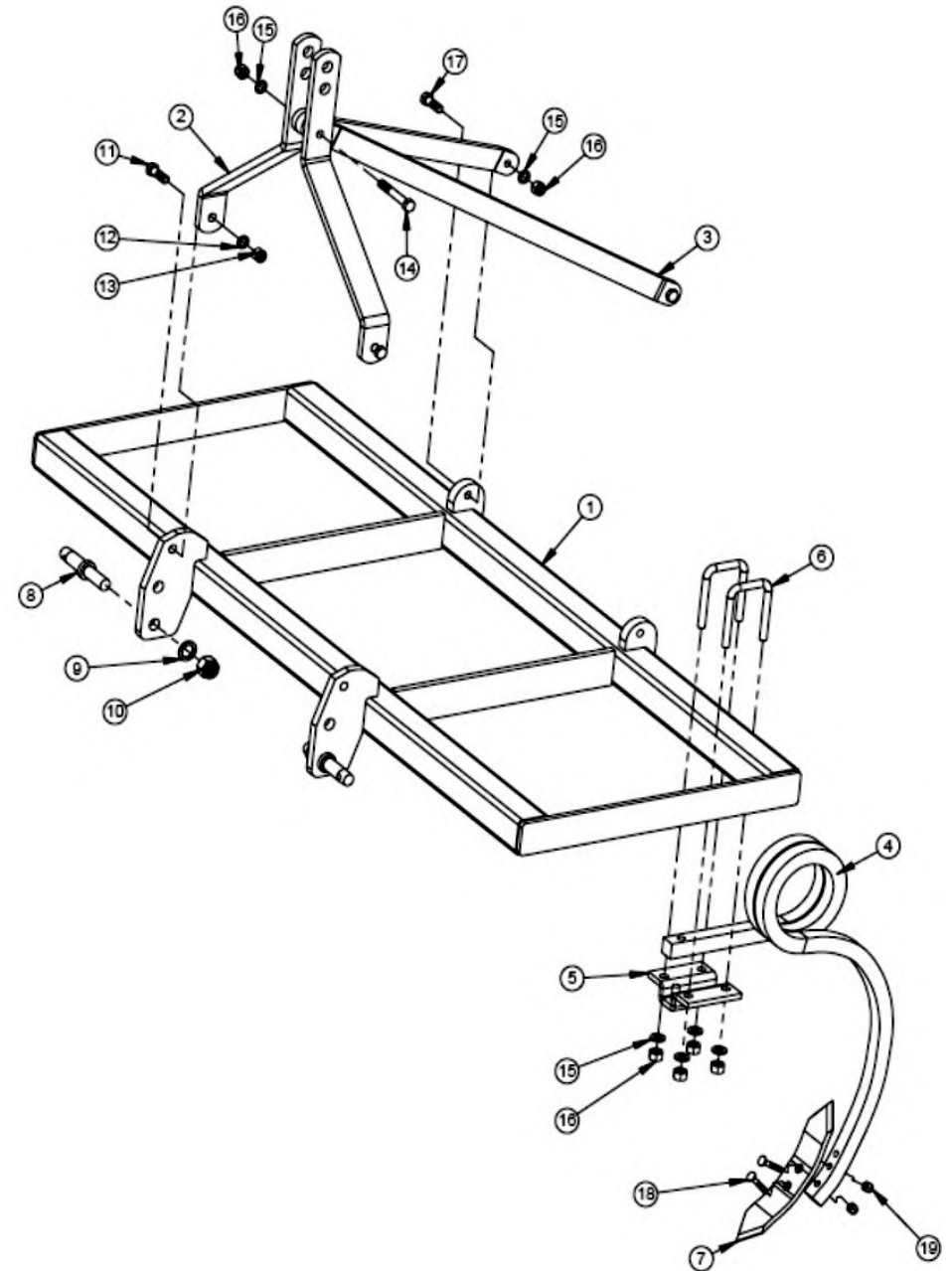

## Multi Row Cultivator

SR.NO.	PART NO.	PART NAME	QTY
1	FKDCT-5021	FRAME ASSEMBLY	1
2	FKDCT-065	REAR LINK MULTIROW	2
3	FKDCT-064	FRONT LINK MULTI ROW	2
4	10260437	HEX HEAD BOLT	1
5	10270006	SPRING WASHER	1
6	10280020	NYLOCK NUT	1
7	FKDCT-066	BUSH	1
8	10020080	PIN	1
9	10260376	HEX HEAD BOLT	2
10	10270006	SPRING WASHER	2
11	10280020	NYLOCK NUT	2
12	10020052	PIN	2
13	10280005	HEX HEAD BOLT	2
14	10270005	SPRING WASHER	3
15	10280005	NYLOCK NUT	3
16	FKDCT-016	TYNE	13
17	76630005	U-CLAMP	13
18		U-CLAMP BRACKET	
19		SPRING WASHER	
20		NYLOCK NUT	
21	FKMRCC-502	FRONT LINK CRUMBLER ASSEMBLY	2
22	10020009	PIN	4
23	FKMRCC-503	REAR LINK CRUMBLER ASSEMBLY	2
24	10020026	PIN	2
25	76630002	U-CLAMP	8
26	10270005	SPRING WASHER	8
27	10280005	NYLOCK NUT	8
28	FKMRCC-501	CRUMBLE ASSEMBLY	1
29	10050033	BEARING	2
30	10260082	HEX HEAD BOLT	4
31	10270006	WASHER	4
32	10280020	NYLOCK NUT	4

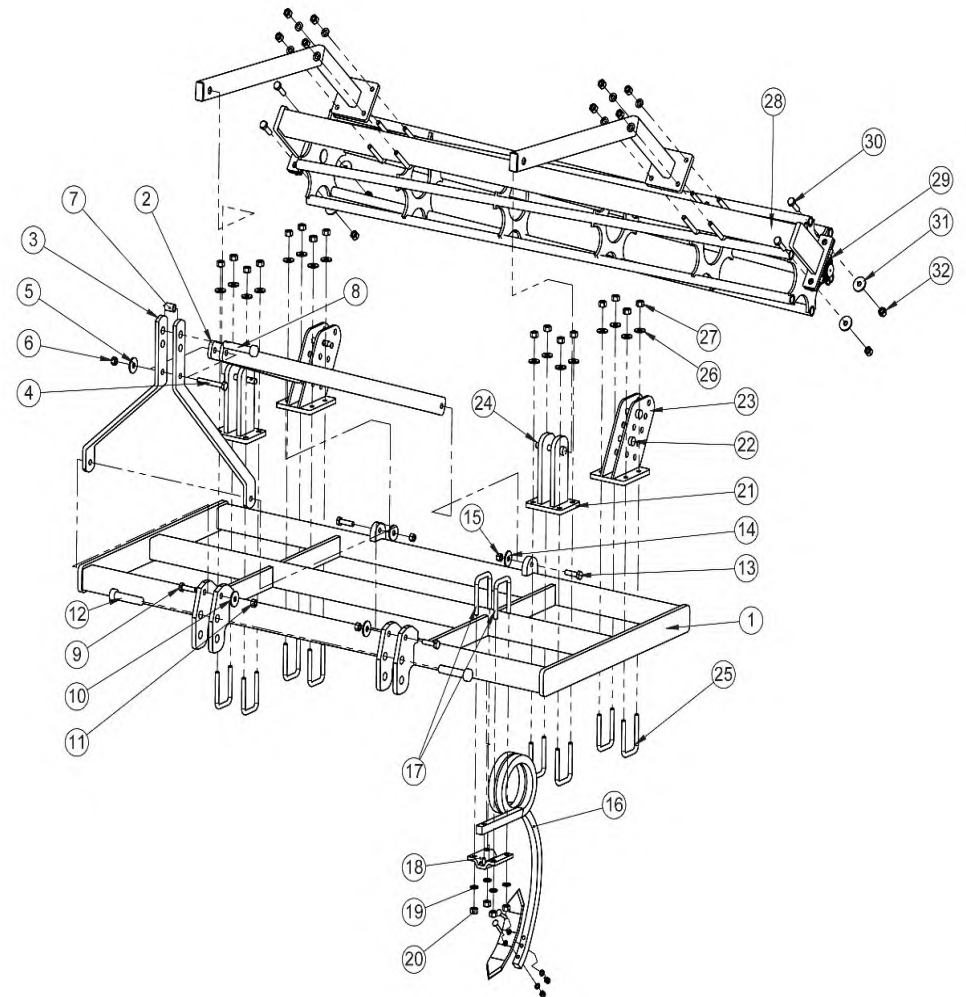

## DELIVERY CHECKLIST

<b>Dealer Pre-Delivery (Please Tick)</b>	<b>Please Complete all Dealer information Below</b>
<p><b>1. Dealer Pre-Delivery Checklist</b></p> <ol style="list-style-type: none"> <li>1. The customer or person responsible has been given the operator's manual.</li> <li>2. The customer undertakes to read the complete operator's manual and understands all aspects of the manual before operation of the machine.</li> <li>3. All safety, operational and maintenance information have been explained and demonstrated.</li> <li>4. All greasing and oil points, stickers, guarding and ID plate have been identified and physically pointed out.</li> <li>5. The customer agrees that it is his responsibility to read and carry out the safety, maintenance and operation as per this operator's manual.</li> </ol>	<p><b>Dealer Information</b></p> <p>Dealer's Name.....</p> <p>Address.....</p> <p>State..... Postcode.....</p> <p>Phone..... Fax.....</p> <p>Email.....</p> <p>Service Person.....</p> <p>I confirm that the pre-delivery service was performed on this machine.</p> <p>Signature.....</p> <p>Date.....</p> <p>Comments.....</p>
<b>Customer Delivery (Please Tick)</b>	<b>Please Complete all Customer Information Below</b>
<p><b>2. Customer Delivery Checklist</b></p> <ol style="list-style-type: none"> <li>1. The customer or person responsible has been given the operator's manual.</li> <li>2. The customer undertakes to read the complete operator's manual and understands all aspects of the manual before operation of the machine.</li> <li>3. All safety, operational and maintenance information have been explained and demonstrated.</li> <li>4. All greasing and oil points, stickers, guarding and ID plate have been identified and physically pointed out.</li> <li>5. The customer agrees that it is his responsibility to read and carry out the safety, maintenance and operation as per this operator's manual.</li> </ol>	<p><b>Customer Information</b></p> <p>Customer's Name.....</p> <p>Address.....</p> <p>State..... Postcode.....</p> <p>Phone..... Fax.....</p> <p>Email.....</p> <p>Delivery Person.....</p> <p>I confirm that all of the delivery checks were explained and performed.</p> <p>Signature.....</p> <p>Delivery Date.....</p> <p>Comments.....</p>



## WARRANTY CARD Customer Copy

CUSTOMER NAME Mr./ Mrs. :

ADDRESS :

MOBILE NO. :

Email :

NAME OF IMPLEMENT :

MODEL NO. :

YEAR OF Mfg. :

SERIAL NO. :

REGISTRATION NO. :

DATE OF PURCHASING :

NAME OF DEALER :

Customer's Signature

Dealer's Signature



**BERI UDYOG PVT LTD**

Corporate Office:

Plot No. 235 to 240, Sec-3, HSIIDC, Karnal- 132001 (Haryana), India

☎ +91 184 2221571/ 72/ 73

✉ info@fieldking.com, www.fieldking.com



**WARRANTY CARD**  
Company Copy

CUSTOMER NAME Mr./ Mrs :

ADDRESS :

MOBILE NO. :

Email :

NAME OF IMPLEMENT :

MODEL NO. :

YEAR OF Mfg. :

SERIAL NO. :

REGISTRATION NO. :

DATE OF PURCHASING :

NAME OF DEALER :

Customer's Signature

Dealer's Signature



**BERI UDYOG PVT LTD**

Corporate Office:

Plot No. 235 to 240, Sec-3, HSIIDC, Karnal- 132001 (Haryana), India

+91 184 2221571/ 72/ 73

info@fieldking.com, www.fieldking.com



**WARRANTY CARD**  
**Dealer Copy**

CUSTOMER NAME Mr./ Mrs :

ADDRESS :

MOBILE NO. :

Email :

NAME OF IMPLEMENT :

MODEL NO. :

YEAR OF Mfg. :

SERIAL NO. :

REGISTRATION NO. :

DATE OF PURCHASING :

NAME OF DEALER :

Customer's Signature

Dealer's Signature



**BERI UDYOG PVT LTD**

Corporate Office:

Plot No. 235 to 240, Sec-3, HSIIDC, Karnal- 132001 (Haryana), India

+91 184 2221571/ 72/ 73

info@fieldking.com, www.fieldking.com