

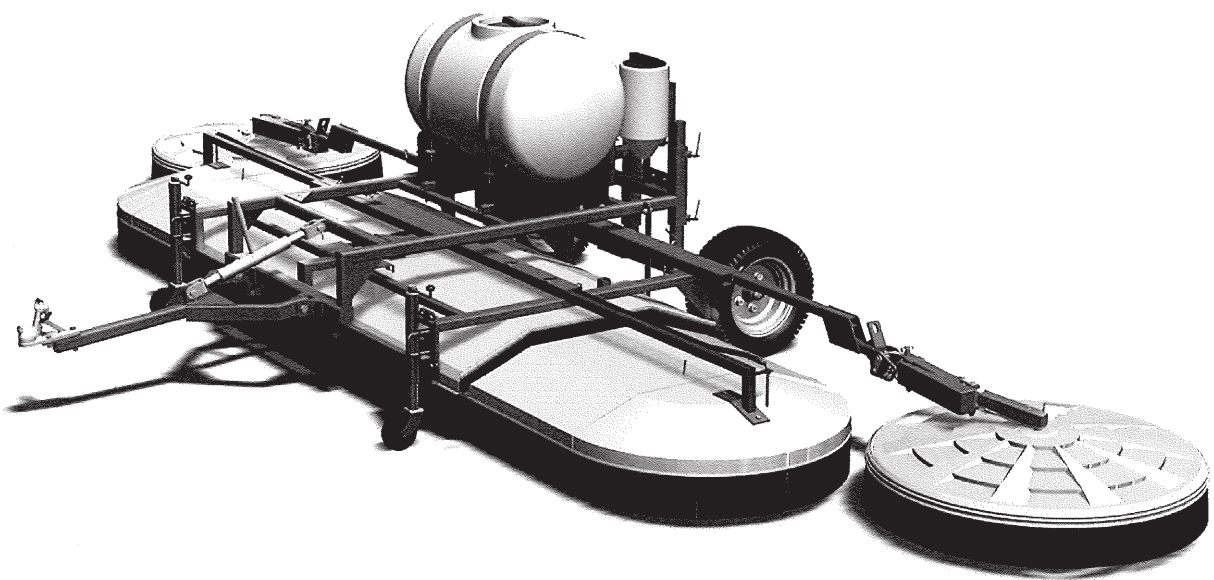

*Spraydome*3049^{CDA}

Adjustable width low profile shielded CDA sprayer



Parts Catalogue

Publication Part No: 10635

Revision: 2.1

Edition Notice

Prepared and printed by or on behalf of:



This publication covers the following products:

Spraydome 3049 CDA

This document is prepared for Micron Sprayers Ltd. their agents and clients. The document should be taken in its entirety. No responsibility can be accepted, nor can consent be assumed for the part reproduction, editing, extract or quotation taken out of context of this document.

All rights reserved. No part of this publication may be reproduced, stored in a retrieval system, or transmitted in any form or by any means, electronic, mechanical, photocopying, recording or otherwise, without the prior permission of Micron Sprayers Ltd.

Copyright © Micron Sprayers Ltd. 2016

Whilst every effort has been made to ensure the accuracy of this document, any errors or inaccuracies should be reported to Micron Sprayers Ltd. or their agents.



Bromyard Industrial Estate

Bromyard

Herefordshire

HR7 4HS

U.K.

T +44 (0)1885 482397

F +44 (0)1885 483043

E enquiries@micron.co.uk

www.microngroup.com

Micron Group is a trading name of Micron Sprayers Ltd. Company Registration No. 00529633 England & Wales

Contents

1	3049 CDA MAJOR ASSEMBLIES AND FIXINGS	6
2	MECHANICAL COMPONENTS	8
2.1	SHIELD ASSEMBLY	8
2.2	CHASSIS COMPONENTS	10
2.3	CARRIAGE FRAME ASSEMBLY	12
2.4	SPRAYDOME 1200 CDA OUTRIGGER ASSEMBLY (OPTIONAL)	14
3	PLUMBING, ATOMISERS AND ANCILLARIES	16
3.1	TANK SYSTEM COMPONENTS	16
3.2	PUMP SYSTEM COMPONENTS	18
3.3	RINSE AND HAND-WASH TANK COMPONENTS	20
3.4	1000/1200 CDA HEAD ASSEMBLY (AA277)	21
3.5	HEAD ASSEMBLY ADJUSTABLE SPRAYDOME	22
3.5.1	CDA HEAD ASSEMBLY WITH ATOMISER DISC - ULVA+ (ZD004)	23
4	CONTROLLER, LAMP TYPE, 6-WAY	24
4.1	POWER WIRE ASSEMBLY	26

Only use spare parts recommended by Micron Group, their agents and/or distributors.

The use of parts not specifically recommended by micron group, their agents and/or distributors may void any warrantee agreements.

Spare parts should only be fitted by suitably qualified and/or experienced persons.

When ordering spare parts, please specify the following information:

- Serial number of system/unit.
- Approximate date of manufacture.
- Description of part.
- Part number as shown in this document.
- Quantity required.

For spare parts and accessories contact:



Bromyard Industrial Estate
Bromyard
Herefordshire
HR7 4HS
U.K.

P.O. Box 1246
Berri 5343
South Australia

T +44 (0)1885 482397
F +44 (0)1885 483043
E enquiries@micron.co.uk

T +61 (0)8 8582 4077
E enquiries@enviromist.com.au

www.microngroup.com

Or your authorised agent:

Agent / Distributor details:

1 3049 CDA MAJOR ASSEMBLIES AND FIXINGS

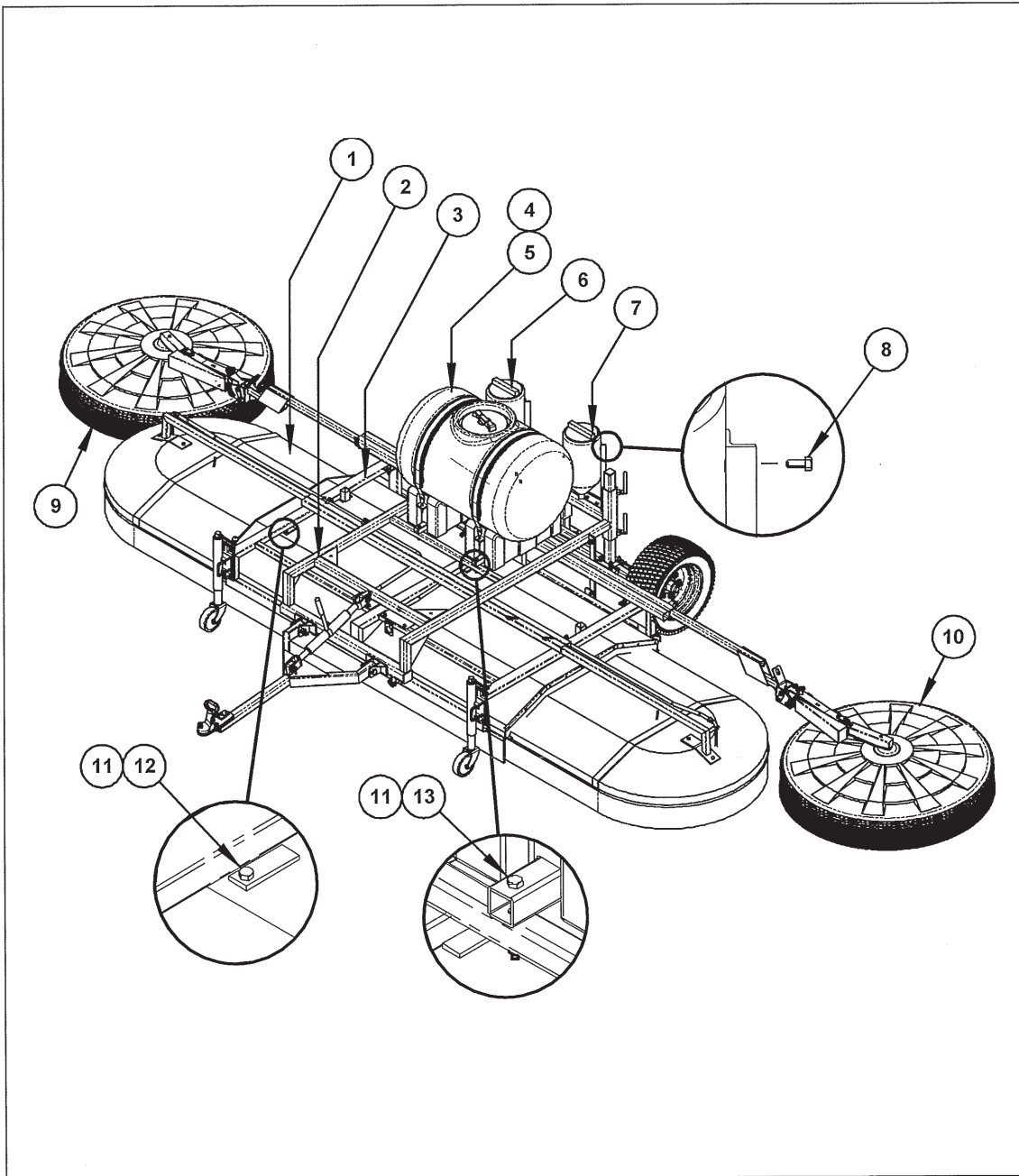

Figure 1 – 3049 CDA Major Assemblies and Fixings

3049 CDA Major Assemblies and Fixings Parts List

ITEM	PART NO.	DESCRIPTION	QTY
1	Section 2.1	SHIELD ASSEMBLY COMPLETE	1
2	Section 2.2	CARRIAGE FRAME ASSEMBLY	1
3	Section 2.2	SHIELD SUPPORT FRAME	1
4	Section 3.1	TANK SYSTEM COMPONENTS	1
5	Section 3.2	PUMP SYSTEM COMPONENTS	1
6	Section 3.3	RINSE TANK COMPONENTS	1
7	Section 3.3	HAND WASH TANK COMPONENTS	1
8	UF210	SCREW M8 x 12	4
9	10452 Section 2.4	RH SD1200 KIT FOR SD3049 COMPLETE	1
10	10453 Section 2.4	LH SD1200 KIT FOR SD3049 COMPLETE	1
11	UF029	NUT, 3/8 BSW, NYLOC, BZP	10
12	UF019	BOLT, 3/8" BSW X 1 1/4"	6
13	UF065	BOLT, 3/8" BSW X 2 1/2" HEX	4

2 MECHANICAL COMPONENTS

2.1 Shield Assembly

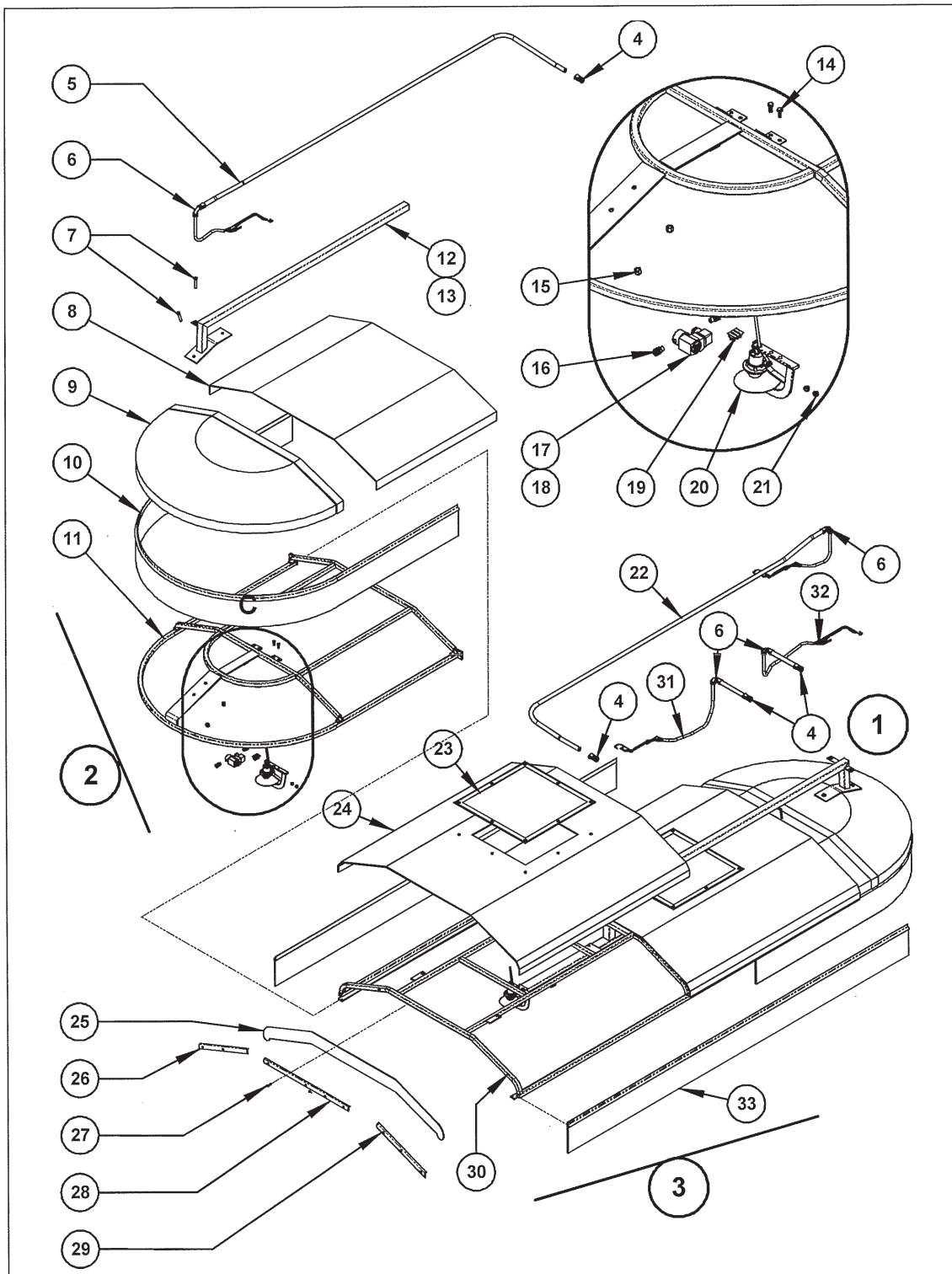

Figure 2 – Shield Assembly

Shield Assembly Parts List

ITEM	PART NO.	DESCRIPTION	Qty
1	ZS560	WING, LH, SD3049, COMPLETE	1
2	ZS559	WING, RH, SD2049, COMPLETE	1
3	ZS561	CENTRE, SD3049, COMPLETE	1
4	GE038	STRAIGHT FITTING, NYLON, 16mm	2
5	ZS265R/9	HOSE AND CABLE ASSEMBLY, RH WING, 3049	1
6	GE052	ELBOE, 90°, ADAPTAFLEX	2
7	UF021	BOLT, 3/8" x 2"	4
8	ZS327	POLY COVER, CENTRE, 3049	2
9	ZS328	PLOY END COVER	2
10	ZS562	BRUSH AND ALUMINIUM, WING, SD3049	2
11	ZS557	FRAME, WING, SD3049	2
12	ZS558	SLIDE INNER, RH, 3049	1
13	ZS228L	SLIDE INNER, LH, SD3049	1
14	UF016	SET SCREW, 1/4" BSW x 3/4"	8
15	UF029	NUT, 3/8 BSW, NYLOC, BZP	4
16	AL014	ADAPTER, 1/8 BSP x 6 mm	2
17	GO001	GOYEN SOLENOID COMPLETE	1
18	UF094	SCREW 6 x 1/2" UNC, ZP	2
19	ZE008	CONNECTOR, 3 WAY	1
20	Section 3.5	HEAD ASSEMBLY, CDA, SPRAYDOME	4
21	UF028	Nut, 1/4" BSW, Nyloc, ZC	4
22	ZS265L/9	HOSE AND CABLE ASSEMBLY, LH WING, 3049	1
23	SM019	ACCESS PANEL COVER , YELLOW (supplied complete with press studs)	2
24	ZS257	POLY COVER, CENTRE, SPRAYDOME	2
25	ZS258	SEAL, RUBBER, ADJUSTABLE SPRAYDOME	1
26	RS044_0.320	ALUMINIUM EXTRUSION	1
27	UF034	POP RIVET, 73AS 6-12	11
28	RS044_0.560	ALUMINIUM EXTRUSION	1
29	RS044_0.320	ALUMINIUM EXTRUSION	1
30	ZS556	FRAME, CENTRE SECTION, SD3049	1
31	ZS265R/2	4 HEAD SDOME RH WING HOSE& CABLE ASSY	
32	ZS265L/2	4 HEAD SDOME LH WING HOSE& CABLE ASSY	
33	ZS241_30-49	BRUSH AND ALUMINIUM MOUNT, SD30/49	2

2.2 Chassis Components

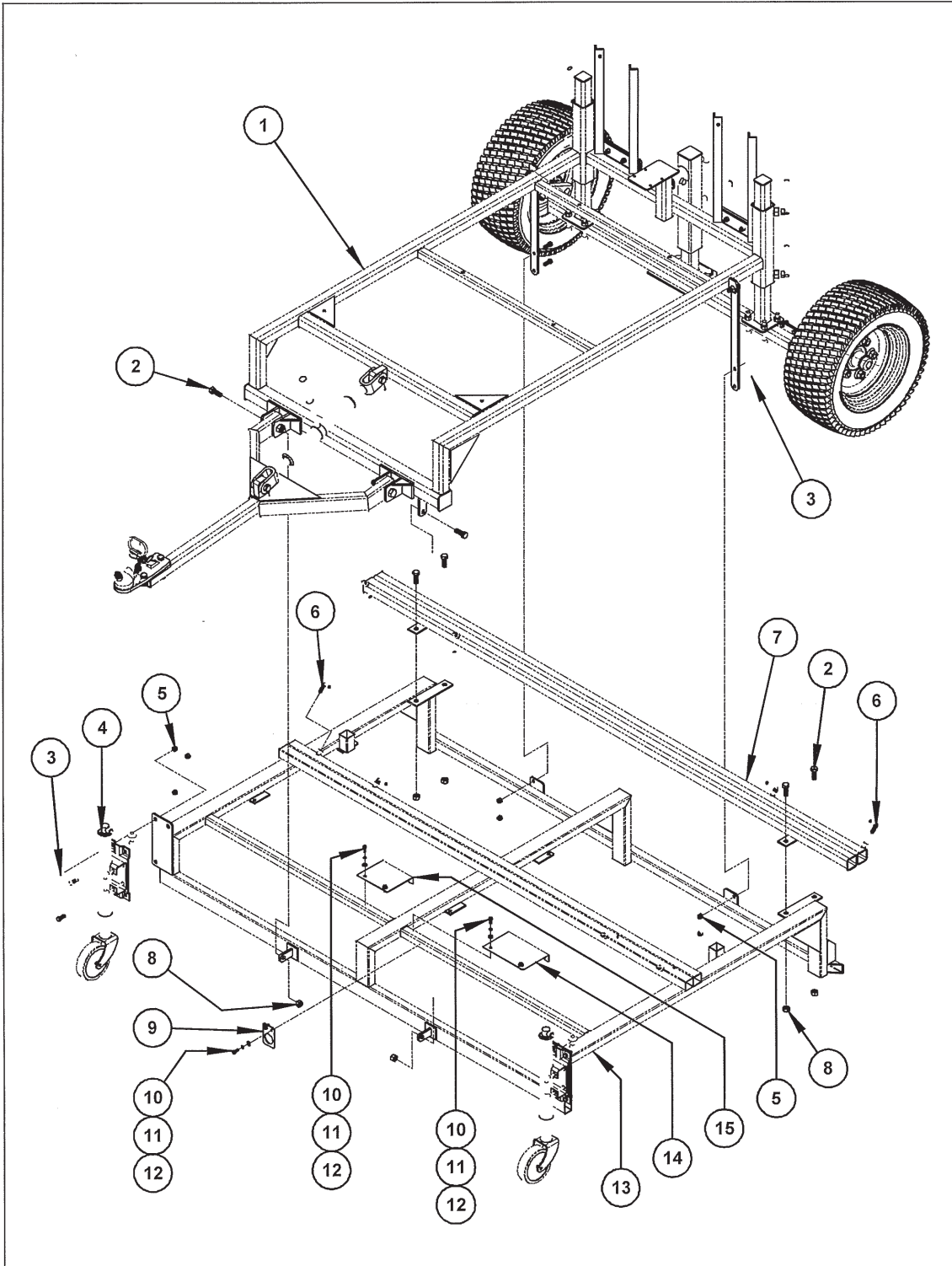

Figure 3 – Chassis Components

Chassis Components Parts List

ITEM	PART NO.	DESCRIPTION	QTY
1	Section 2.3	CARRIAGE FRAME ASSEMBLY	1
2	UF037	BOLT, 1-2BSWx1-1-2 ZC	6
3	UF018	BOLT, 3/8" BSW x 1"	10
4	ST053	JOCKEY WHEEL, 90° SWIVEL	2
5	UF029	NUT, 3/8 BSW, NYLOC, BZP	10
6	ZU015	CLAMP BOLT	8
7	9186	SLIDE TUBES, OUTER	1
8	UF030	NUT, 1/2" BSW NYLOC ZC	6
9	9191	CONDUIT MOUNTING PLATE	1
10	UF016	SET SCREW, 1/4" BSW x 3/4"	6
11	UF083	WASHER, SPRING, 1/4 x 1/8 x 1/16, ZP	6
12	UF004	WASHER, FLAT, 1/4" x 5/8 x 18G, ZP	6
13	9185	SHIELD SUPPORT FRAME	1
14	9193	4 CONDUITS MOUNTING BRACKET	1
15	9192	3 CONDUITS MOUNTING BRACKET	1

2.3 Carriage Frame Assembly

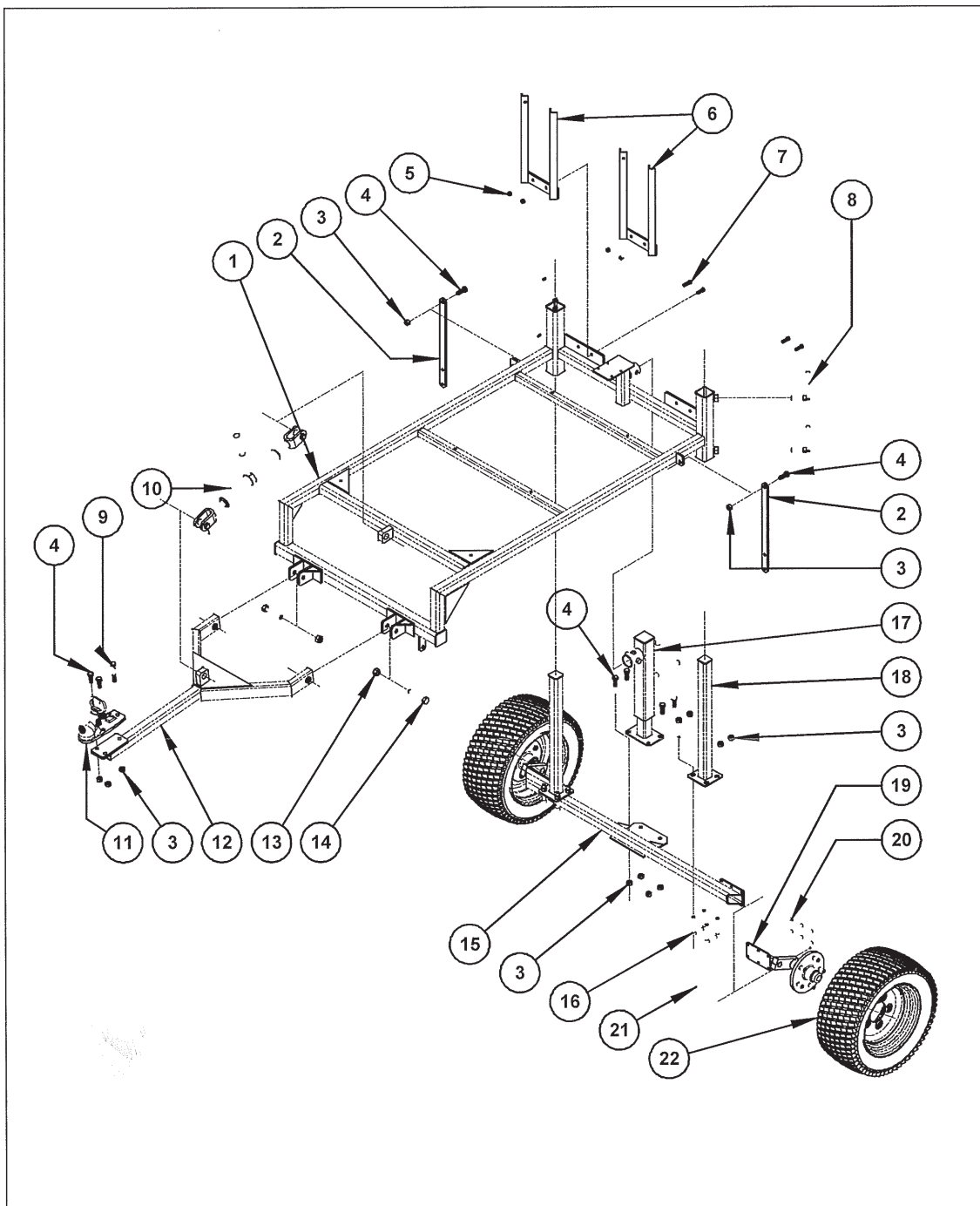

Figure 4 – Carriage Frame Assembly

Carriage Frame Assembly Parts List

ITEM	PART NO.	DESCRIPTION	QTY
1	9131	SD3049 CARRIER FRAME	1
2	9139	REAR HEIGHT ADJUSTMENT ARM	2
3	UF030	NUT, 1/2" BSW NYLOC ZC	17
4	UF037	BOLT, 1-2BSWx1-1-2 ZC	8
5	UF029	NUT, 3/8 BSW, NYLOC, BZP	4
6	9135	SMALL TANK MOUNT	2
7	UF019	BOLT, 3/8" BSW X 1 1/4"	4
8	10607	CLAMP BOLT 5/8" x 2"	4
9	UF038	1/2"BSW x 3"1/2 ZC HEX BOLT - 1"3/8 LG THREAD	1
10	10603	RATCHET (FRONT HEIGHT ADJUSTMENT)	1
11	10606	TOW EYE	1
12	9134	TOW BAR A FRAME	1
13	UF069	5/8" BSW ZC NYLOC NUT	2
14	UF093	5/8"BSW x 3"1/2 ZC HEX BOLT - 1"5/8 LG THREAD	2
15	9133	WHEEL MOUNT	1
16	SC005	U-BOLT, M10 (WHEEL MOUNT)	4
17	10609	JACK, REAR HEIGHT ADJUSTMENT <i>AG001</i>	1
18	9132	VERTICAL SUPPORT, WHEEL MOUNT	2
19	ZS283	SUSPENSION ASSEMBLY, WITH FIXINGS AND WHEEL NUTS	2
20	UF052	NUT, NYLOC, 5/16 BSW	6
21	UF041	SET SCREW, 5/16 BSW x 1 zp	6
22	ST045	WHEEL AND TYRE ASSEMBLY, 23 x 10.5-12	2

2.4 Spraydome 1200 CDA Outrigger Assembly (Optional)

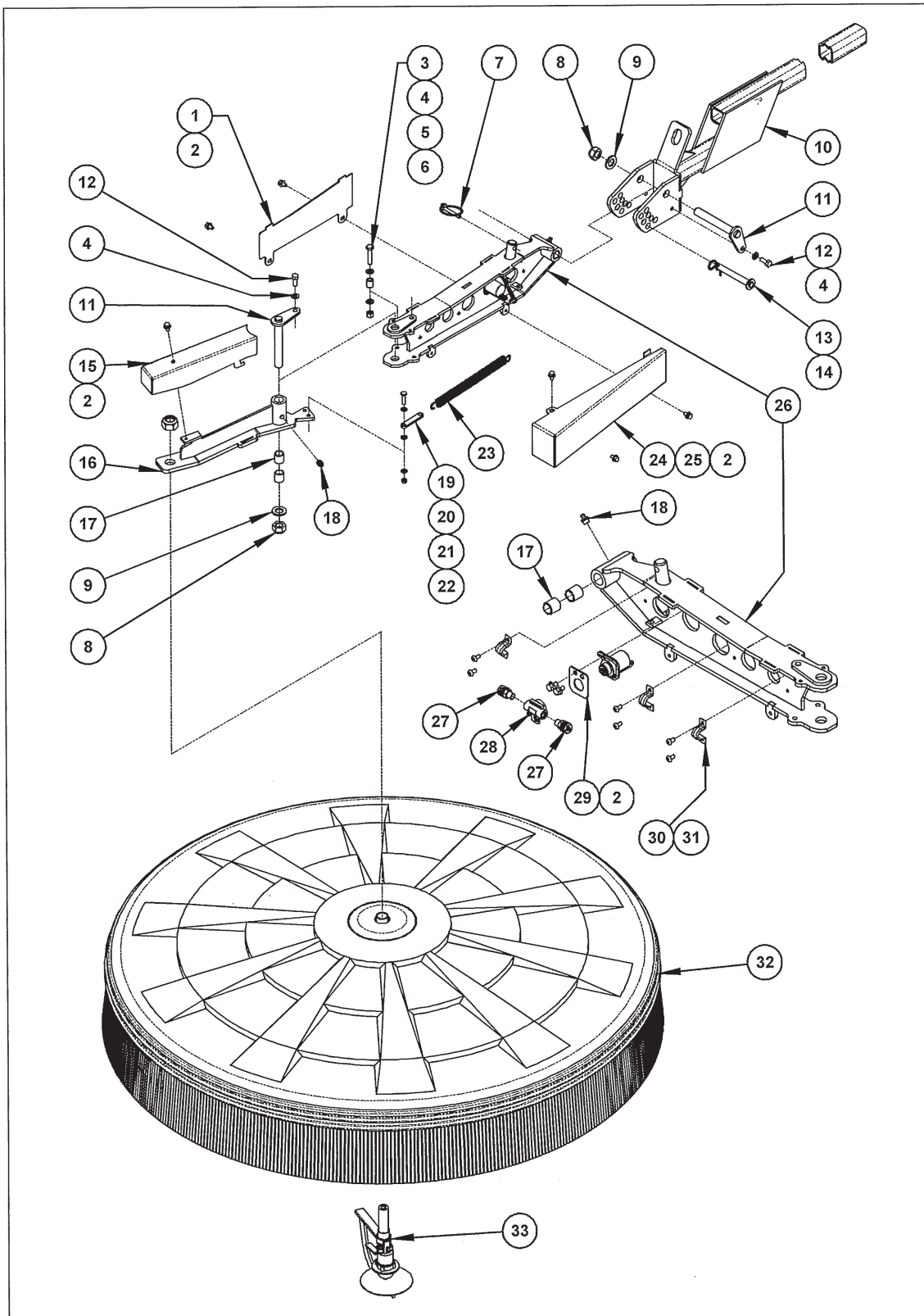
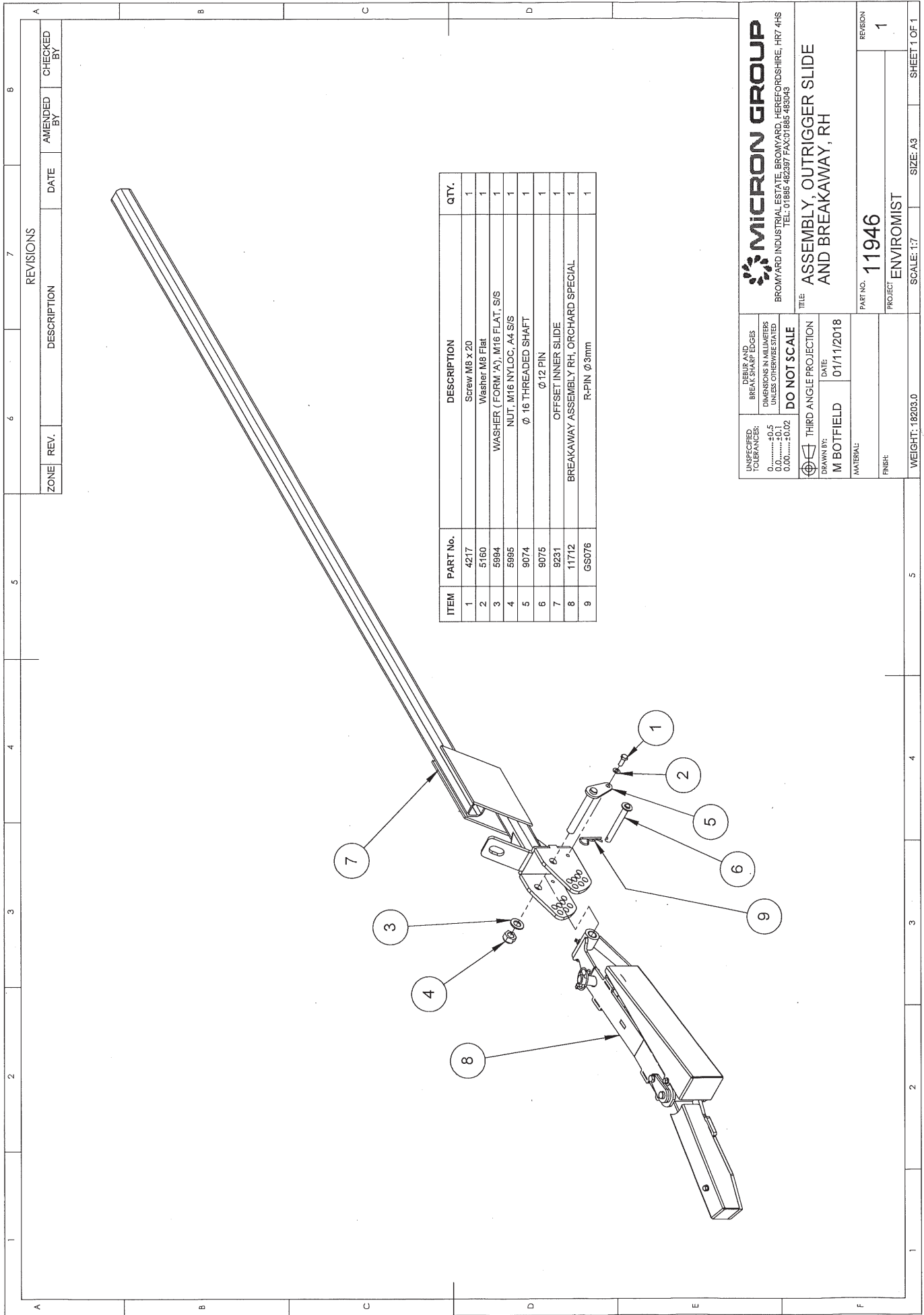

Figure 5 – Spraydome 1200 CDA Outrigger Assembly



ITEM	PART No.	DESCRIPTION	QTY.
1	4217	Screw M8 x 20	1
2	5160	Washer M8 Flat	1
3	5994	WASHER (FORM 'A'), M16 FLAT, S/S	1
4	5995	NUT, M16 NYLOC, A4 S/S	1
5	9074	Ø 16 THREADED SHAFT	1
6	9075	Ø 12 PIN	1
7	9231	OFFSET INNER SLIDE	1
8	11712	BREAKAWAY ASSEMBLY RH, ORCHARD SPECIAL	1
9	GS076	R-PIN Ø3mm	1

MICRON GROUP
 BROMYARD INDUSTRIAL ESTATE, BROMYARD, HEREFORDSHIRE, HR7 4HS
 TEL: 01885 482397 FAX: 01885 483043

ASSEMBLY, OUTRIGGER SLIDE AND BREAKAWAY, RH

UNSPECIFIED TOLERANCES:
 0.0.....±0.5
 0.0.....±0.1
 0.00.....±0.02

DEBUR AND BREAK SHARP EDGES
 DIMENSIONS IN MILLIMETERS
 UNLESS OTHERWISE STATED

DO NOT SCALE

THIRD ANGLE PROJECTION

DRAWN BY: M BOTFIELD
 DATE: 01/11/2018

MATERIAL:
 FINISH:

PART NO. **11946**
 PROJECT: ENVIROMIST
 REVISION: 1

WEIGHT: 18203.0
 SCALE: 1:1
 SIZE: A3
 SHEET 1 OF 1

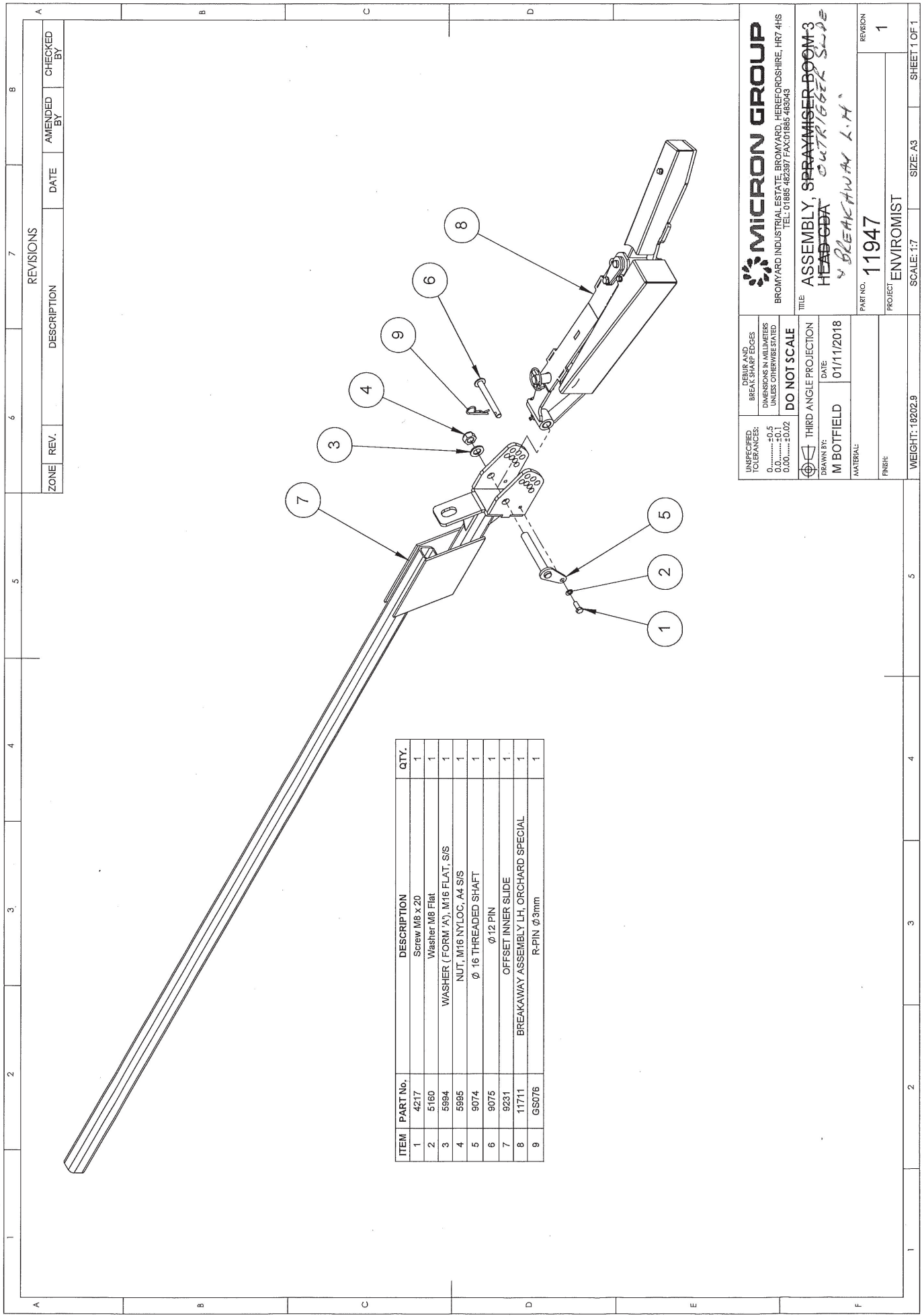

ITEM	PART No.	DESCRIPTION	QTY.
1	4217	Screw M8 x 20	1
2	5160	Washer M8 Flat	1
3	5994	WASHER (FORM A), M16 FLAT, SIS	1
4	5995	NUT, M16 NYLOC, A4 SIS	1
5	9074	Ø 16 THREADED SHAFT	1
6	9075	Ø 12 PIN	1
7	9231	OFFSET INNER SLIDE	1
8	11711	BREAKAWAY ASSEMBLY LH, ORCHARD SPECIAL	1
9	G8076	R-PIN Ø 3mm	1

REVISIONS

ZONE	REV.	DESCRIPTION	DATE	AMENDED BY	CHECKED BY

MICRON GROUP
 BROMYARD INDUSTRIAL ESTATE, BROMYARD, HEREFORDSHIRE, HR7 4HS
 TEL: 01865 482397 FAX: 01865 483043

TITLE: **ASSEMBLY, SPRAYMISER BOOM 3 HEAD-ODA**
OUTRIGGER SLIDE
BREAKAWAY L.H.

PART NO. **11947**

PROJECT: **ENVIROMIST**

REVISION: **1**

UNSPECIFIED TOLERANCES: BREAK SHARP EDGES
 DIMENSIONS IN MILLIMETERS UNLESS OTHERWISE STATED
 0.0000.....±0.5
 0.0000.....±0.02
DO NOT SCALE

THIRD ANGLE PROJECTION
 DATE: 01/11/2018
 DRAWN BY: M BOTFIELD
 MATERIAL:
 FINISH:

WEIGHT: 19202.9
 SCALE: 1:1
 SIZE: A3
 SHEET 1 OF 1

Spraydome 1200 CDA Outrigger Assembly Parts List

ITEM	PART NO.	DESCRIPTION	QTY
1	9072	CHASSIS ARM REAR GUARD	2
2	9106	HEX HEAD FLANGE SCREW M6x10, 8.8, ZN PLT	8
3	9103	SCREW M8x40 S/S A2	1
4	5160	WASHER, FLAT,	4
5	9081	STOP TUBE	1
6	5159	NUT M8	1
7	GS014	LINCHPIN 1/4" (6mm)	1
8	5995	NUT, M16 NYLOC, A4 S/S	2
9	5994	WASHER (FORM 'A'), M16 FLAT, S/S	2
10	9231	OFFSET INNER SLIDE <i>9068</i>	1
11	9074	Ø 16 THREADED SHAFT	2
12	6292	SCREW M8x20 S/S A2	2
13	9075	Ø12 PIN	1
14	GS076	R-PIN Ø3mm	1
15	9073	PIVOT ARM GUARD	2
16	9070	PIVOT ARM	1
17	9083	SELF LUBRICATING BEARING - 16 x 20 x 20LG	4
18	7699	GREASE NIPPLE - 1/8" BSP - STRAIGHT	2
19	ZU005	CONNECTING LINK	1
20	5971	SCREW M6 x 25 HEX	1
21	5722	WASHER M6	3
22	5984	NUT, M6 NYLOC	1
23	IE005	TENSION SPRING	1
24	9090	CHASSIS ARM RH FRONT GUARD	1
25	9071	CHASSIS ARM LH FRONT GUARD	1
26	9069	CHASSIS ARM	1
27	AL014	ADAPTER, 1/8 BSP x 6 mm	2
28	BI044	SOLENOID	1
29	9789	SOLENOID MOUNT BRACKET	1
30	GE001	SADDLE CLAMP 16 mm	3
31	9232	SOCKET SCREW, M5 x 10, BUTTON HEAD	6
32	ZU065	SPRAYDOME 1200 DOME ASSEMBLY ¹	1
33	AA277 Section 3.4	HEAD ASSEMBLY, 1000/1200 CDA	1

¹ Replacement bearing available part number GB002 and replacement retaining clip part number GB003

3 PLUMBING, ATOMISERS AND ANCILLARIES

3.1 Tank System Components

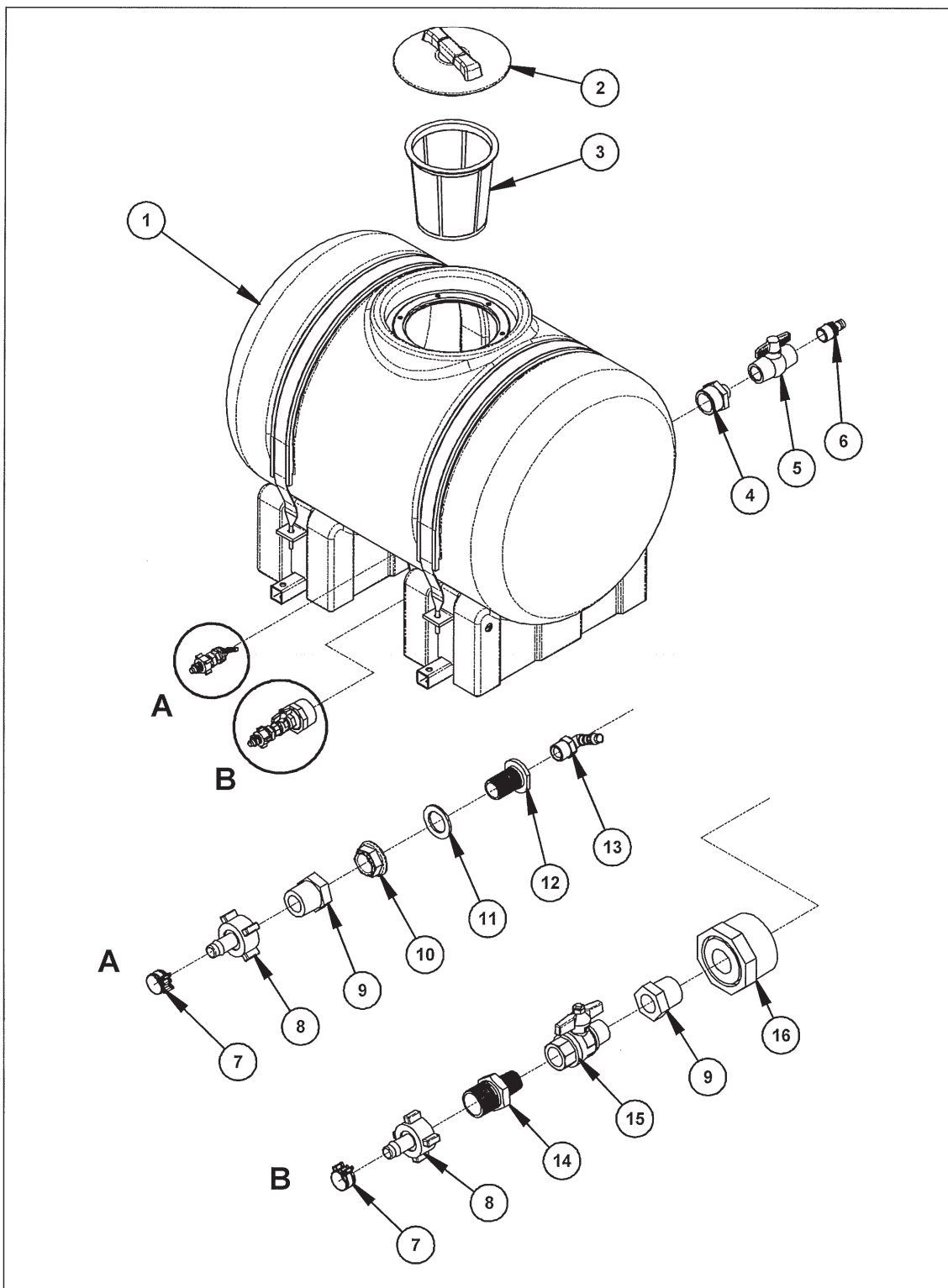

Figure 6 – Tank System Components

Tank System Components Parts List

ITEM	PART NO.	DESCRIPTION	QTY
1	TP001	200 LITRE TANK WITH MOUNT, CAP AND BASKET	1
2	TP003	LID	1
3	TP004	STRAINER BASKET	1
4	BI048	ADAPTER, 2" x 1" M/F	1
5	BI046	BALL VALVE, 1", PVC	1
6	BI045	HOSE BARB, 3/4" x 1" BSP	1
7	NH006	HOSE CLIP, 17 mm	2
8	BI023	HOSE BARB, (NUT AND TAIL) N3412	2
9	BI006	ADAPTER, 3/4" x 1/2" M/F	2
10	HN009	BACK NUT, 1/2"	1
11	HN010	SEAL, BACK NUT, 1/2"	1 ¹
12	ZT034	FLANGE, BULKHEAD, 1/2"	1 ¹
13	AL037	HOSE BARB, ELBOW, 8 mm x 3/8 BSP	1 ¹
14	BI010	ADAPTER, 3/4" x 1/2" M/M	1
15	BI081	BALL VALVE, 15 mm, M/F, BRASS	1
16	BI042	ADAPTER, 2" x 3/4" M/F	1

¹ Fitted to inside of tank

3.2 Pump System Components

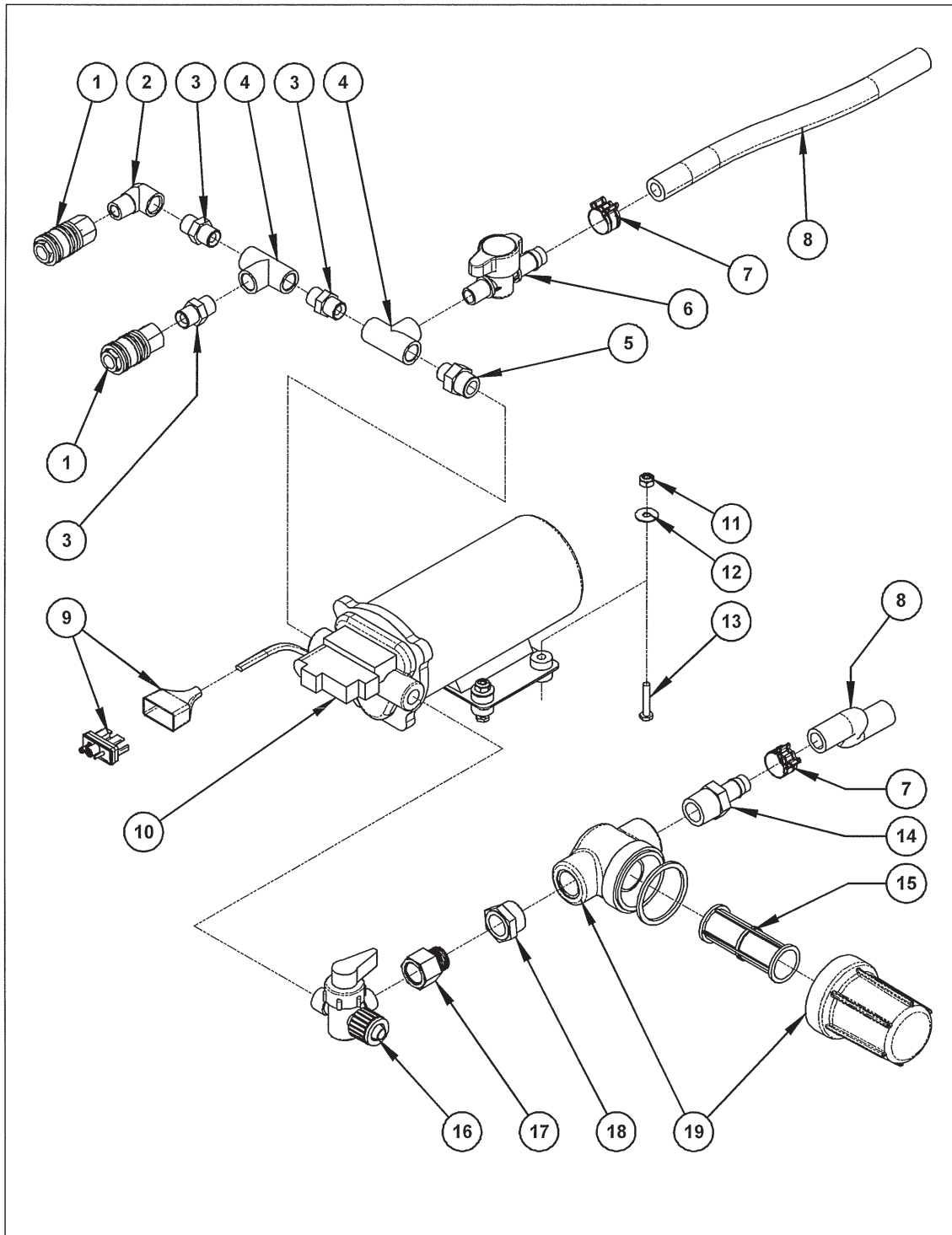

Figure 7 – Pump System Components

Pump System Components Parts List

ITEM	PART NO.	DESCRIPTION	QTY
1	AL001	SOCKET, QUICK RELEASE, 1/4" BSPT F	2
2	BI032	ELBOW, 1/4" M/F, BRASS	1
3	BI009	ADAPTER, 1/4" M/M	3
4	BI033	TEE, 1/4", BRASS	2
5	AL019	ADAPTER, 3/8" x 1/4" M/M	1
6	ZT032	VALVE, GREENBACK, MODIFIED	1
7	NH006	HOSE CLIP, 17 mm	2
8	BI001	HOSE, 1/2"	1 ¹
9	ST008	PLUG, 2 PIN (MALE), IN-LINE	1
10	RM010	PUMP, 7.7 L/min 3/8" NPTF(BYPASS)	1
11	UF027	NUT, 10-24, NYLOC	4
12	UF003	WASHER, FLAT, 3-16 x 5-8 x 18 g	4
13	UF015	SET SCREW, 3-16 BSW x 1	4
14	BI025	HOSE BARB, 1/2" x 1/2"	1
15	8044	FILTER ELEMENT, 80 MESH, BLUE	1
16	ZT033	VALVE, 3 WAY	1
17	AL026	ADAPTER, 3/8 x 3/8	1
18	BI076	ADAPTER, 3/8" x 1/2" BSP M/F	1
19	CL040	FILTER HOUSING, 1/2" (COMPLETE)	1

¹ When ordering this item, please state the length required in metres

3.3 Rinse and Hand-Wash Tank Components

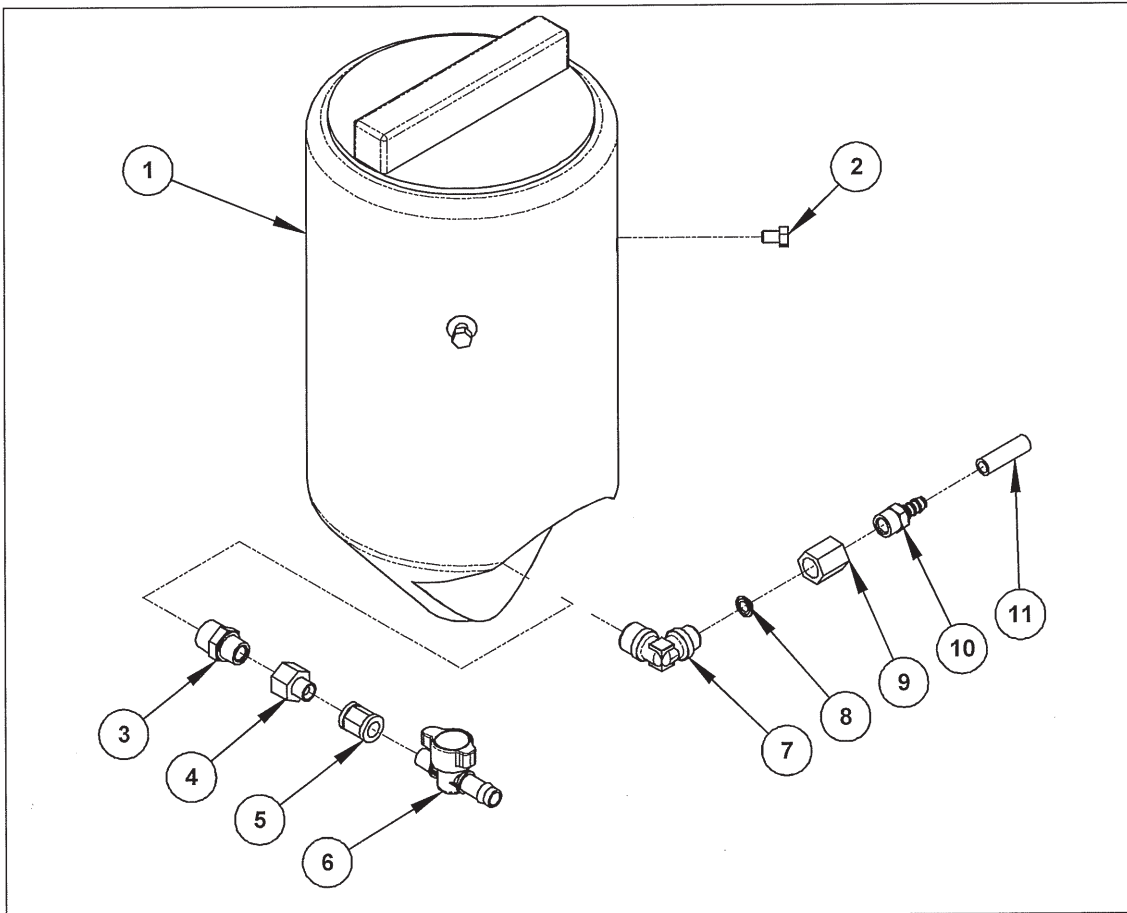
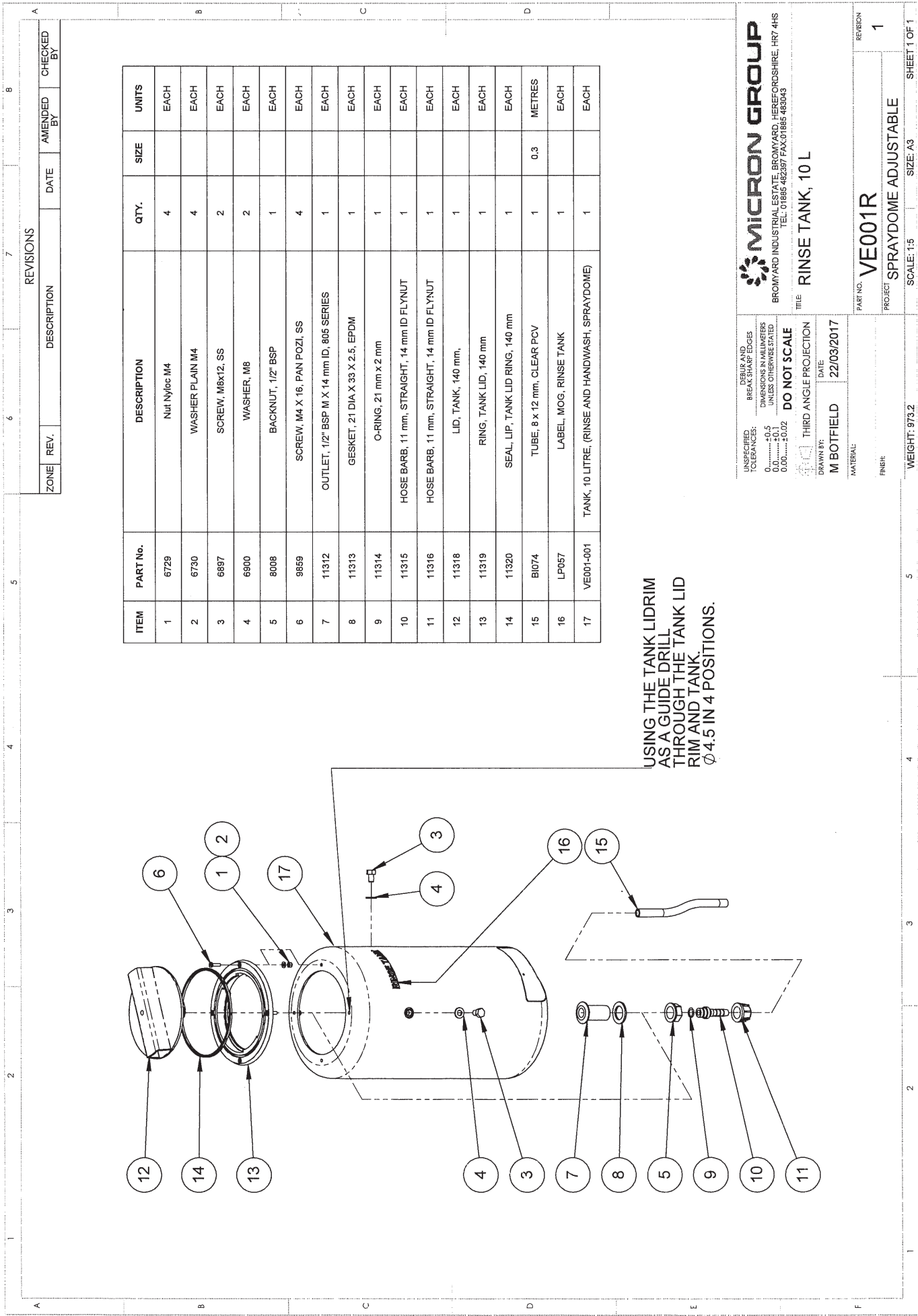

Figure 8 – Rinse and Hand-Wash Tank Components

ITEM	PART NO.	DESCRIPTION	QTY.
1	VE001	TANK, 10 LITRE, (RINSE AND HAND WASH)	1
2	UF210	SCREW, M8 x 12	2
3	AL042	REDUCING NIPPLE, 1/2 x 3/8	1
4	AL007	ADAPTER, 1/4" x 3/8" MF	1
5	BI003	COUPLING, 1/4" FF	1
6	ZT032	VALVE, GREENBACK, MODIFIED	1
7	AL025	ELBOW, 1/2" x 3/8" M/M	1
8	CL073	FILTER (CUP STRAINER), 50 MESH	1
9	BI004	COUPLING, 3/8" F	1
10	AL015	HOSE BARB 8 mm x 3/8"	1
11	BI074	TUBE, 8 x 12 mm, CLEAR PCV	1 ¹

¹ When ordering this item, please state the length required in metres



USING THE TANK LID RIM AS A GUIDE DRILL THROUGH THE TANK LID RIM AND TANK. \varnothing 4.5 IN 4 POSITIONS.

ITEM	PART No.	DESCRIPTION	QTY.	SIZE	UNITS
1	6729	Nut Nylon M4	4		EACH
2	6730	WASHER PLAIN M4	4		EACH
3	6897	SCREW, M8x12, SS	2		EACH
4	6900	WASHER, M8	2		EACH
5	8008	BACKNUT, 1/2" BSP	1		EACH
6	9859	SCREW, M4 X 16, PAN POZI, SS	4		EACH
7	11312	OUTLET, 1/2" BSP M X 14 mm ID, 805 SERIES	1		EACH
8	11313	GESKET, 21 DIA X 33 X 2.5, EPDM	1		EACH
9	11314	O-RING, 21 mm x 2 mm	1		EACH
10	11315	HOSE BARB, 11 mm, STRAIGHT, 14 mm ID FLYNUT	1		EACH
11	11316	HOSE BARB, 11 mm, STRAIGHT, 14 mm ID FLYNUT	1		EACH
12	11318	LID, TANK, 140 mm,	1		EACH
13	11319	RING, TANK LID, 140 mm	1		EACH
14	11320	SEAL, LIP, TANK LID RING, 140 mm	1		EACH
15	B1074	TUBE, 8 x 12 mm, CLEAR PCV	1	0.3	METRES
16	LP057	LABEL, MOG, RINSE TANK	1		EACH
17	VE001-001	TANK, 10 LITRE, (RINSE AND HANDWASH, SPRAYDOME)	1		EACH

MICRON GROUP
 BROMYARD INDUSTRIAL ESTATE, BROMYARD, HEREFORDSHIRE, HR7 4HS
 TEL: 01865 482387 FAX: 01865 483048

UNSPECIFIED TOLERANCES: DECIMAL AND BREAKS/SHARP EDGES DIMENSIONS IN MILLIMETERS
 0.0000.....±0.5
 0.0000.....±0.2
 0.0000.....±0.02
DO NOT SCALE

THIRD ANGLE PROJECTION

DATE: 22/03/2017
 DRAWN BY: M BOTFIELD

MATERIAL:
 FINISH:

PART NO: VE001R
 PROJECT: SPRAYDOME ADJUSTABLE
 SCALE: 1:5
 REVISION: 1

TITLE: RINSE TANK, 10 L

WEIGHT: 973.2

SHEET 1 OF 1

3.4 1000/1200 CDA Head Assembly (AA277)

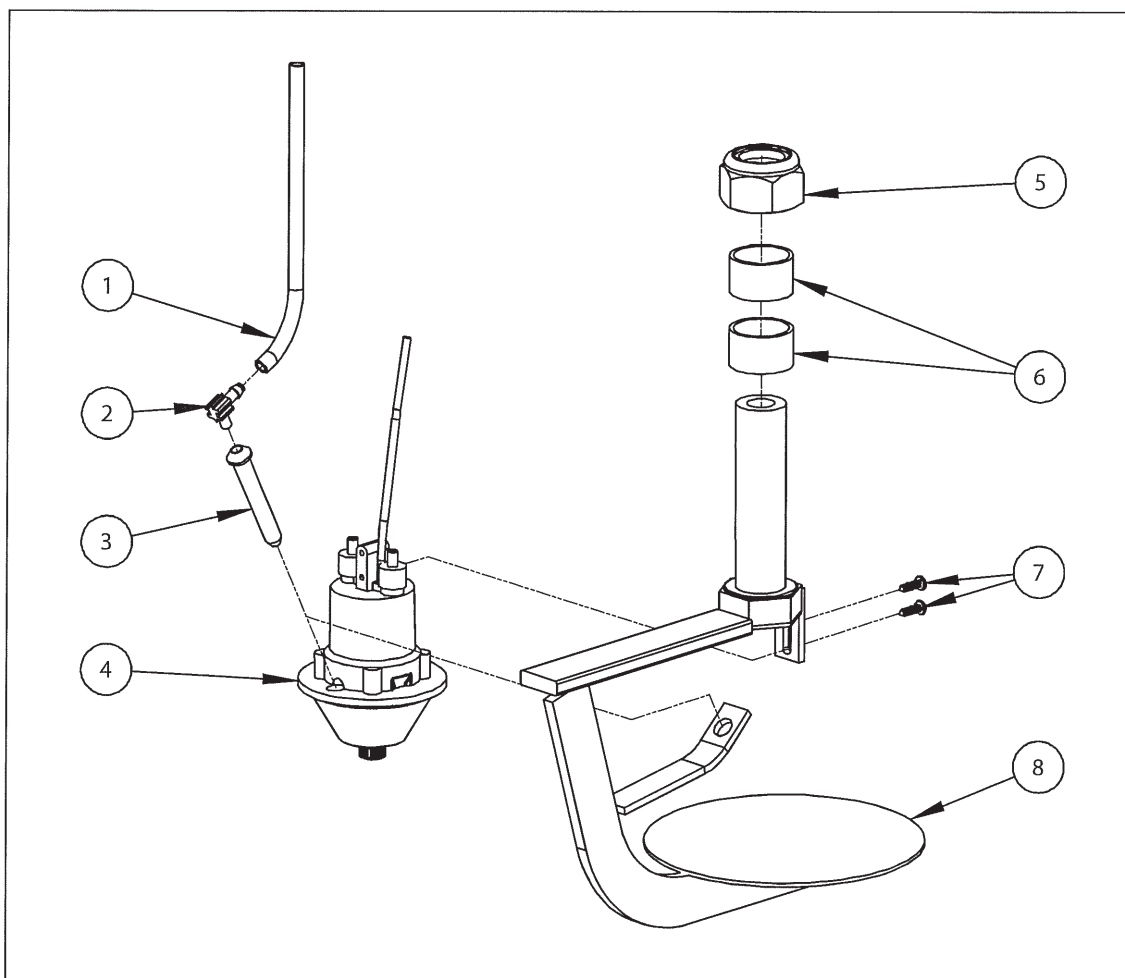

Figure 9 – 1000/1200 CDA Head Assembly

ITEM	PART NO.	DESCRIPTION	QTY.
1	ZD009	FEED TUBE 6 mm	1 ¹
2	ZU023	ELBOW EB4 (MODIFIED)	1
3	MI013	FEED NOZZLE, BLUE	1
4	ZD004 Section 3.5.1	CDA HEAD WITH ATOMISER DISC (ULVA+)	1
5	UF031	NUT, NYLOC, M20	1
6	ZD001	SPACER	2
7	UF010	SCREW, SELF TAPPING, 4BA X 1/2"	2
8	ZD003	1000/1200 HEAD BRACKET	1

¹ When ordering this item, please state the length required in metres

3.5 Head Assembly Adjustable Spraydome

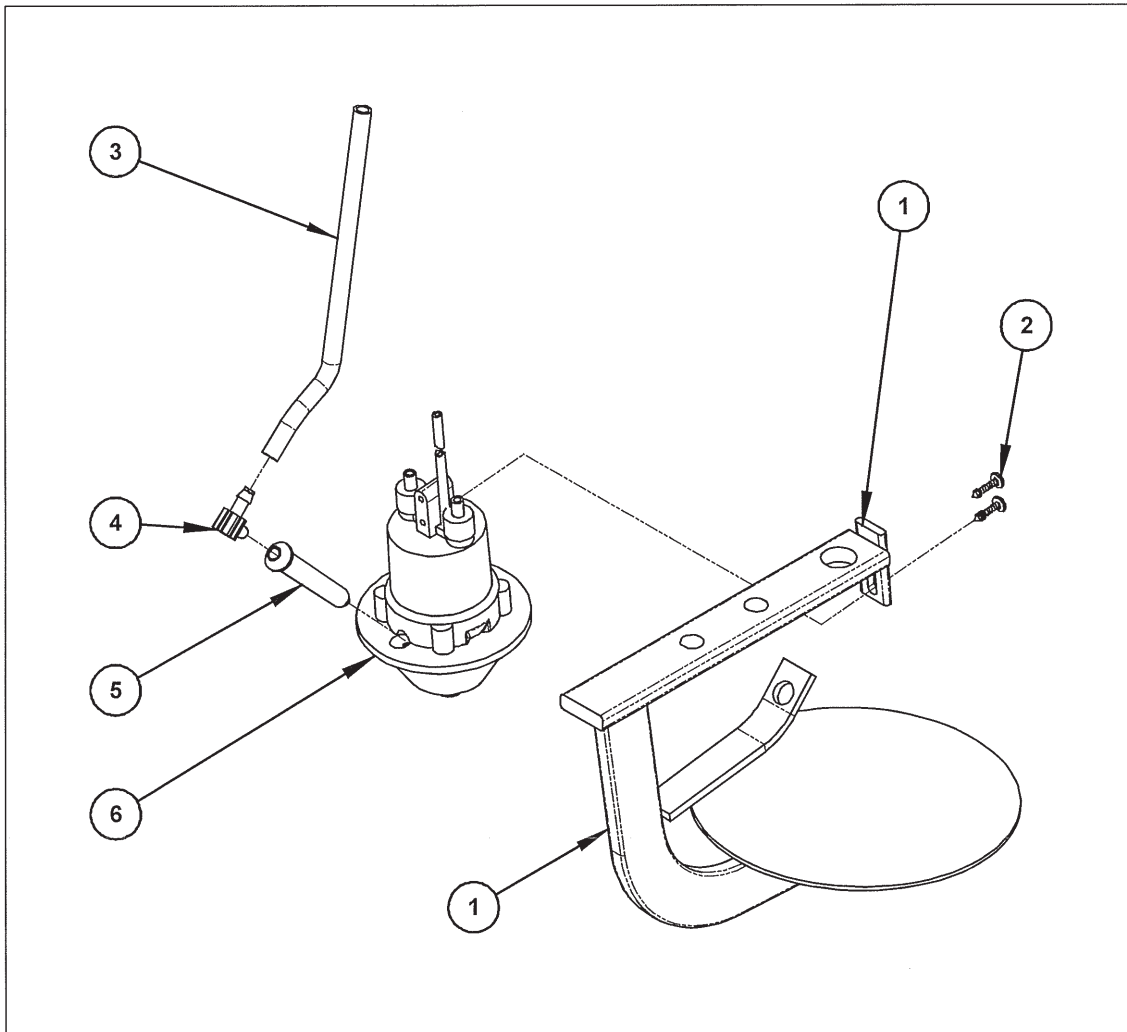

Figure 10 – Head Assembly Adjustable Spraydomey

ITEM	PART NO.	DESCRIPTION	QTY.
1	ZS202	HEAD BRACKET, ADJUSTABLE SPRAYDOME	1
2	UF010	SCREW, SELF TAPPING, 4BA x 1/2"	2
3	ZD009	FEED TUBE, 6 mm	1 ¹
4	ZU023	ELBOW, EB4 (MODIFIED)	1
5	MI013	FEED NOZZLE, BLUE	1
6	ZD004 Section 3.5.1	CDA HEAD WITH ATOMISER DISK (ULVA+)	1

¹When ordering this item, please state the length required in metres

3.5.1 CDA Head Assembly with Atomiser Disc - Ulva+ (ZD004)

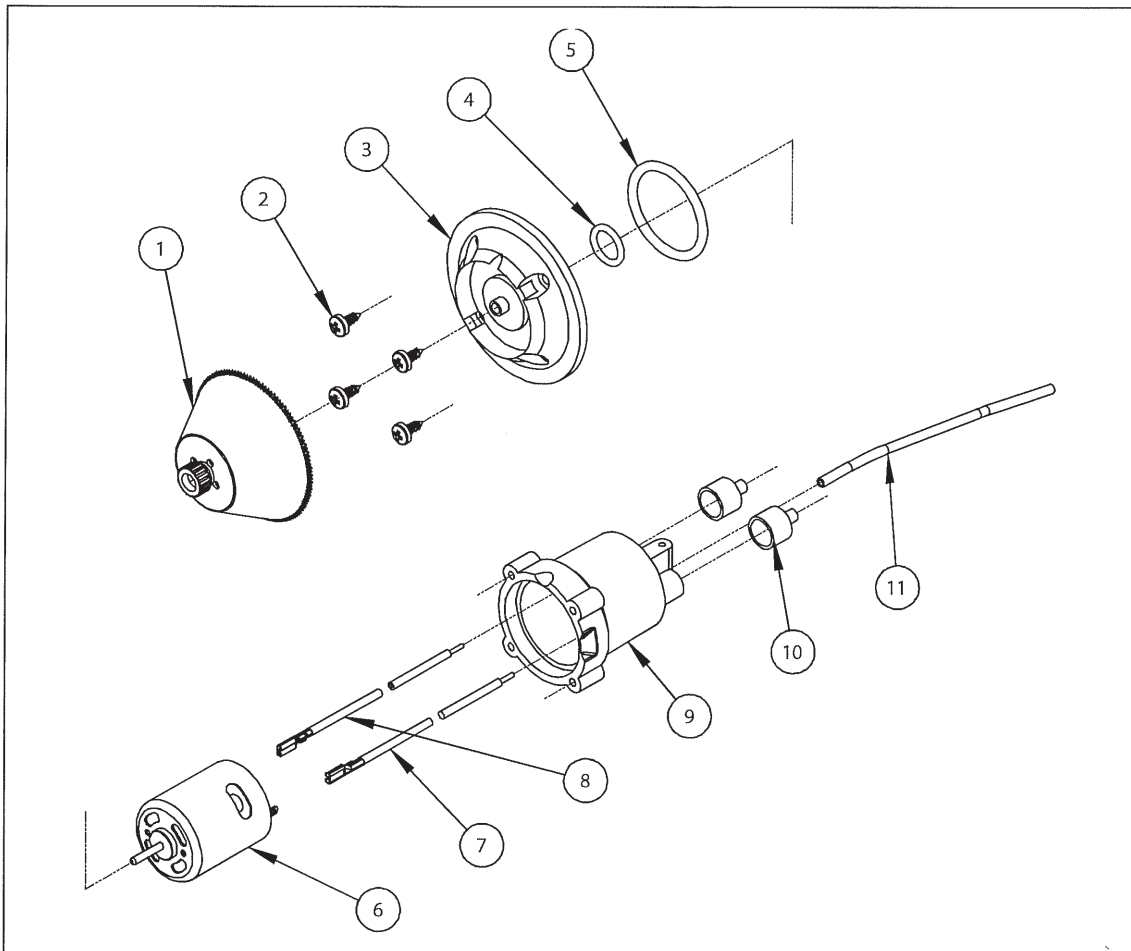

Figure 11 – CDA Head Assembly with Atomiser Disc - Ulva+ (ZD004)

ITEM	PART NO.	DESCRIPTION	QTY.
1	MI025	ATOMISER DISC ASSEMBLY	1
2	5399	SCREW, PAN HEAD, NO.6 X 3/8" SS	4
3	MI046	MOTOR FRONT PLATE, GREEN	1
4	5398	O-RING (ULVA+ MOTOR SHAFT)	1
5	5403	O-RING (ULVA+ MOTOR BODY)	1
6	MI009	MOTOR (ULVA+)	1
7	4134T	WIRE 1 MM X 0.24 M, BLACK (WITH TERMINAL)	1
8	4368T	WIRE 1 MM X 0.24 M, RED (WITH TERMINAL)	1
9	MI045	MOTOR HOUSING, GREEN	1
10	6717	BOOT, RUBBER	2
11	3512_20	BREATHER TUBE	1

4 CONTROLLER, LAMP TYPE, 6-WAY

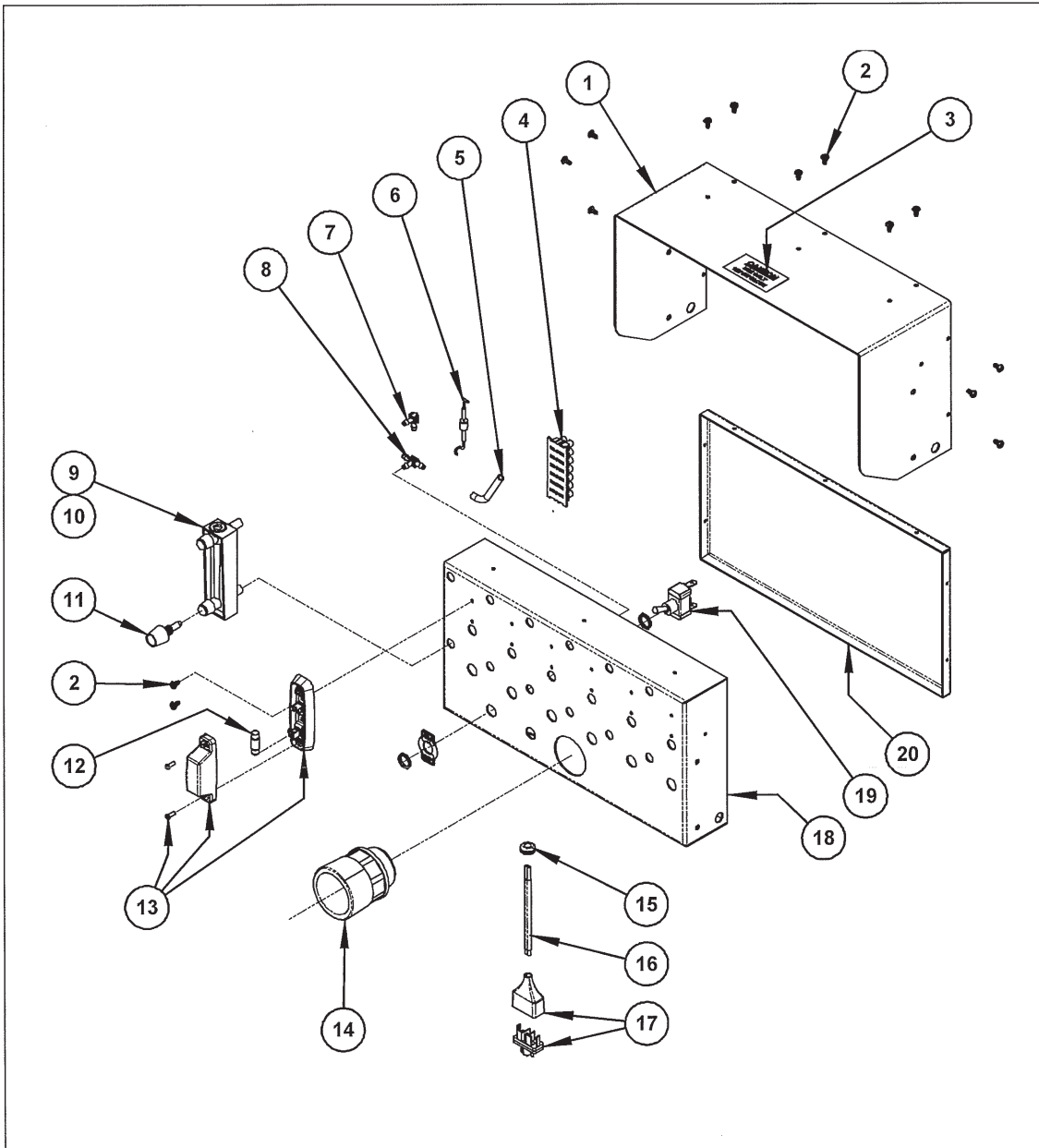

Figure 12 – Controller, Lamp Type, 6-Way

Controller, Lamp Type, 6-Way - Parts List

ITEM	PART NO.	DESCRIPTION
1	10035	6 UNIT CONTROL BOX OUTER
2	UF048	SCREW, SELF TAP, 6-20 x 3/8" ZP
3	CB006	LABEL, CAUTION 12V 5W
4	ZE013	CONNECTOR BLOCK, 7 WAY
5	BI040	MICRO HOSE, 6 mm ¹
6	ZC010A	DIODE ASSEMBLY
7	BI017	ELBOW, EB4
8	BI020	TEE, BARBED, 4 mm
9	DI002	FLOW METER, 30 LITRES PER HOUR
10	DI004	FLOAT, FLOW METER
11	ZU039	TRIMMER FOR FLOW METER-DI002
12	ST003	GLOBE, 12V 5W
13	ST004	LAMP ASSEMBLY
14	GE054	ADAPTAFLEX M40 STRAIGHT FITTING
15	ST007	GROMMET, 14.3 mm
16	ZC022	BACKPLATE FEED WIRE ¹
17	ST008	PLUG, 2 PIN (MALE), IN-LINE
18	10033	6 UNIT CONTROL BOX INNER
19	ST005	SWITCH, TOGGLE, 10A 250VAC
20	10034	6 UNIT CONTROL BOX BACKING

↓ 6 PRONG FEED

¹ When ordering this item, please state the length required in metres

4.1 Power Wire Assembly

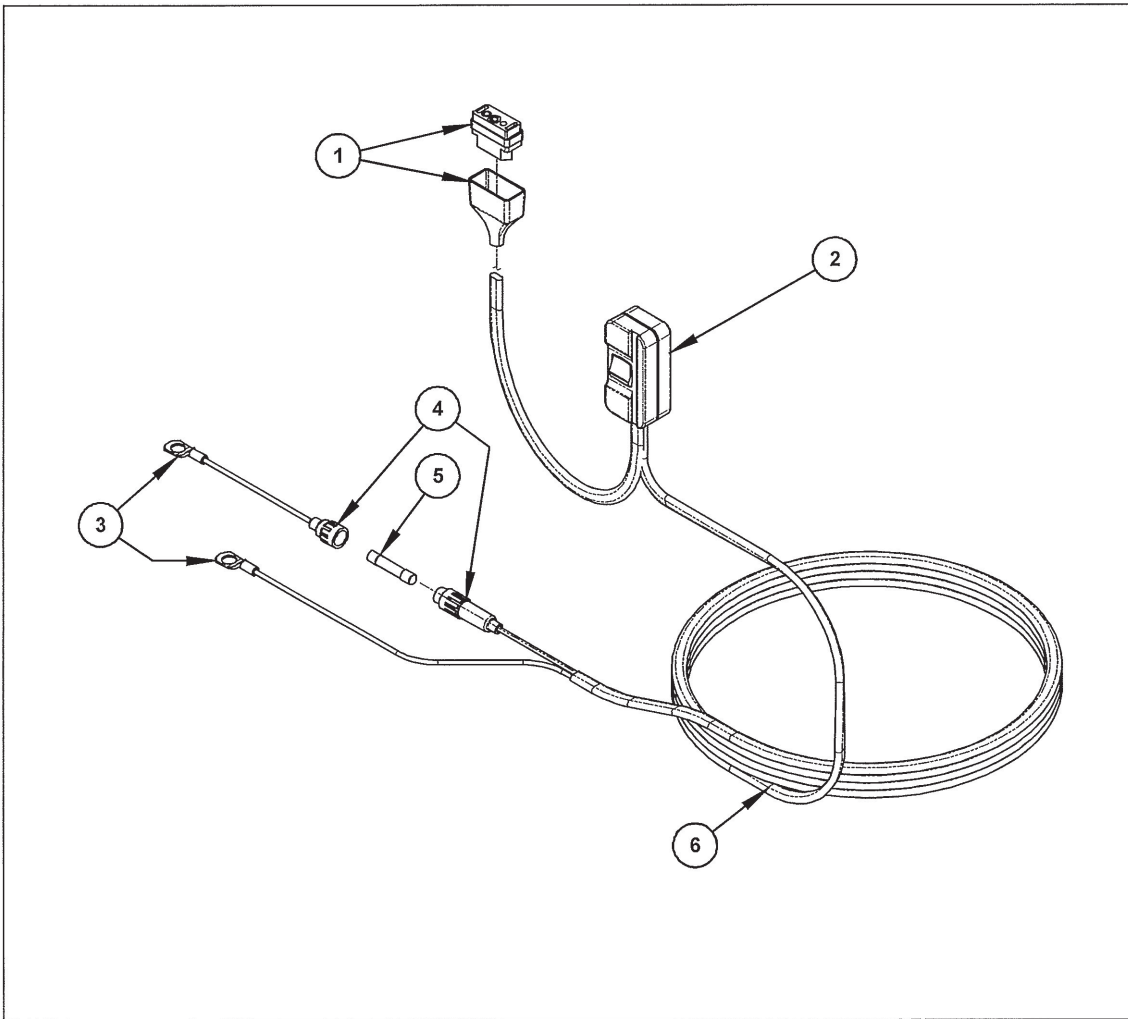

Figure 13 – Power Wire Assembly

ITEM	PART NO.	DESCRIPTION	QTY.
1	ST009	SOCKET, 2 PIN, INLINE	1
2	GE035	SWITCH, INLINE	1
3	GE021	TERMINAL, M8, MT4	2
4	ST001	FUSE HOLDER	1
5	ST002	FUSE, 10A	1
6	GE012	CABLE, 2 CORE, RED/BLACK	1 ¹

¹When ordering this item, please state the length required in metres

