



ISO9001认证



CE欧盟安全认证



WOOD CHIPPER OPERATION MANUAL

Model: BX42 BX62R

! CAUTION: Read Manual Thoroughly Before Operator

CONTENTS

| | |
|-------------------------------|----|
| CONTENTS | 1 |
| SAFETY INSTRUCTIONS | 2 |
| SAFETY TRAINING | 5 |
| ASSEMBLY INSTRUCTIONS | 15 |
| OPERATION | 19 |
| TRANSPORTING | 48 |
| STORAGE | 50 |
| SERVICE AND MAINTENANCE | 52 |
| TROUBLE SHOOTING | 60 |
| SPECIFICATIONS | 61 |
| PARTS LIST | 64 |

SAFETY INSTRUCTIONS

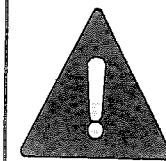

Before operating the Wood Chipper read the following safety instructions. Failure to comply with these warnings may result in serious injury or death.

READ AND FOLLOW THE READ AND FOLLOW THE ESPECIALLY IN THE SAFETY SECTION. FAILURE TO DO SO CAN RESULT IN SERIOUS INJURY OR DEATH.

SIGNAL WORDS: The signal words **DANGER**, **WARNING** and **CAUTION** are used with the safety messages in this manual and with each safety sign. They are defined as follows:

DANGER: Indicates an immediate hazardous situation that, if not avoided, could result in serious injury or death. This signal word is to be limited to the most extreme situations typically for machine components that, for functional purposes, cannot be guarded.

WARNING: Indicates a potentially hazardous situation that, if not avoided, could result in serious injury or death, and includes hazards that are exposed when guards are removed. It may also be used to alert against unsafe practices.

CAUTION: Indicates a potentially hazardous situation that, if not avoided, may result in minor or moderate injury. It may also be used to alert against unsafe practice.

SAFETY INSTRUCTIONS

EQUIPMENT SAFETY GUIDELINES

Safety of the operator and bystanders is one of the main concerns in designing and developing a wood chipper. However, every year accidents occur which could have been avoided by a few seconds of thought and a more careful approach to handling equipment. You, the operator, can avoid many accidents by observing the following precautions and insist those working with you, or for you, follow them.

In order to provide a better view, certain photographs or illustrations in this manual may show an assembly with a safety shield removed. However, equipment should never be operated in this condition. Keep all shields in place. If shield removal becomes necessary for repairs, replace the shield prior to use.

Replace any safety sign that is not readable or missing. Location of such safety signs are indicated in this manual.

Never use alcoholic beverages or drugs that can hinder alertness or coordination while operating this equipment. Consult your doctor about operating this machine while taking prescription medications.

Under no circumstances should children under the age of 18 be allowed to work with this equipment. Do not allow persons to operate or assemble this unit until they have read this manual and have developed a thorough understanding of the safety precautions and how it works. Review the safety instructions with all users annually.

This equipment is dangerous to children and persons

SAFETY INSTRUCTIONS

unfamiliar with its operation. The operator should be a responsible, properly trained and physically able person familiar with farm machinery and trained in this equipment's operations. If the elderly are assisting with farm work, their physical limitations need to be recognized and accommodated.

Use a tractor equipped with a Roll Over Protective System and seat belts. (ROPS)

Never exceed the limits of a piece of machinery. If its ability to do a job, or to do so safely, is in question-**DON'T TRY IT.**

Do not modify the equipment in any way. Unauthorized modification could result in serious injury or death and may impair the function and life of the equipment.

In addition to the design and the confirmation of this implement, including safety signs and safety equipment, hazard control and accident prevention are dependent upon the awareness, concern, prudence, and proper training of personnel involved in the operation, transport, maintenance, and storage of the machine. Refer also to safety messages and operation instruction in each of the appropriate sections of the tractor and wood chipper manuals. Pay close attention to the safety signs affixed to the tractor and the wood chipper.

SAFETY TRAINING

Safety is a primary concern in the design and manufacturing of our product. Unfortunately, our efforts to provide safe equipment can be wiped out by a single careless act of an operator or bystander.

In addition to the design and configuration of equipment, hazard control and accident prevention are dependent upon the awareness, concern, prudence and proper training of personnel involved in the operation, transport, maintenance and storage of this equipment.

It has been said, "The best safety device is an informed, careful operator." We ask you to be that kind of operator. It is the operator's responsibility to read and understand all safety and operating instructions in the manual and to follow them. Accidents can be avoided.

Working with unfamiliar equipment can lead to careless injuries. Read this manual, and the manual for your tractor, before assembly or operating, to acquaint yourself with the machines. If this machine is used by any person other than you, or is loaned or rented, it is the wood chipper owner's responsibility to make certain that the owner's manual be available to the operator prior to operating:

- 1-Reads and understands the operator's manuals.
- 2-Is instructed in safe and proper use.

Know your controls and how to stop the tractor, engine, and wood chipper quickly in an emergency. Read this manual and the one provided with your tractor.

Train all new personnel and review instructions frequently with existing workers. Be certain only a properly trained and physically able person will operate

SAFETY TRAINING

the machinery. A person who has not read and understood all operating and safety instructions is not qualified to operate the machine. An untrained operator exposes himself and bystanders to possible serious injury or death. If the elderly are assisting with farm work, their physical limitations need to be recognized and accommodated.

PREPARATION

Never operate the tractor and wood chipper until you have read and completely understand this manual, the Tractor Operator's Manual, and each of the safety messages found on the safety signs on the tractor and wood chipper.

Personal protection equipment including hardhat, safety glasses, safety shoes, and gloves are recommended during assembly, installation, operation, adjustment, maintenance, repairing, removal, or moving the implement. Do not allow long hair, loose fitting clothing, or jewelry to be around equipment.

PROLONGED EXPOSURE TO LOUD NOISE MAY CAUSE PERMANENT HEARING LOSS! Tractors with or without wood chippers attached can often be noisy enough to cause permanent, partial hearing loss. We recommend that you wear hearing protection on a full-time basis if the noise in the operator's position exceeds 80 db. Noise over 80 db on a long-term basis can cause severe hearing loss. Noise over 90 db adjacent to the operator over a long-term basis may cause permanent, total hearing loss. **NOTE:** Hearing loss from loud noise (from tractors, chain saws, radios, and other such sources close to the ear) is cumulative over a lifetime without hope of natural recovery.

SAFETY TRAINING

Operate the wood chipper only with a tractor equipped with an approved Roll-Over-Protective System (ROPS). Always wear your seat belt. Serious injury or even death could result from falling off the tractor — particularly during a turnover when the operator could be pinned under the ROPS or the tractor.

Operate only in daylight or good artificial light.

Ensure wood chipper is properly mounted, adjusted and in good operating condition.

Ensure that all safety shielding and safety signs are properly installed and in good condition.

STARTING AND STOPPING SAFETY

Check the tractor master shield over the PTO stub shaft. Make sure it is in good condition and fastened securely to the tractor. Purchase a new shield if old shield is damaged or missing.

All tractors that are not equipped with a “live” power takeoff (PTO) need to be equipped with an over-running PTO clutch. These are available through most farm equipment stores. NOTE: The addition of an over-running PTO clutch may change the length of the PTO driveline required. Pay extra attention to the instructions on the PTO Driveline Installation. Be sure that the driveline system guarding is adequate.

Wood chipper operating power is supplied from the tractor PTO. Refer to your tractor manual for PTO engagement and disengagement instructions. Know how to stop tractor and wood chipper quickly in case of an emergency.

SAFETY TRAINING

When engaging PTO, the engine RPM should always be at idle speed. Once engaged and ready to start working, raise PTO speed to 540-RPM and maintain throughout working operation.

OPERATIONAL SAFETY

The use of this equipment is subject to certain hazards that cannot be protected against by the mechanical means or product design. All operators of this equipment must read and understand this entire manual, paying particular attention to safety and operating instructions, prior to using. If there is something in this manual you do not understand, ask your supervisor, or your dealer, to explain it to you.

Most accidents occur because of neglect or carelessness. Keep all helpers and bystanders at least several hundred feet from an operating rotary wood chipper. Only properly trained people should operate this machine.

When machine is operated in populated areas where thrown objects could injure persons or property, operation must be stopped when anyone comes within several hundred feet.

The majority of the accidents involve entanglement on the driveline, injury of bystanders by the objects thrown by the rotating tines, and operators being knocked off the tractor by low hanging limbs and then being run over by the wood chipper. Accidents are most likely to occur with machines that are loaned or rented to someone who has not read the owner's manual and is not familiar with a rotary wood chipper.

The rotary wood chipper is designed for use only on

SAFETY TRAINING

tractors with the power take-off (PTO) turning at 540-RPM.

Install and secure all guards and shields before starting or operating. The wood chipper tines, driveline guards and tractor, shields should be used and maintained in good working condition. They should be inspected care-fully, at least daily, for missing or broken chain links, shields, or guards. (Worn items must be replaced at once to reduce possibility of injury.)

Disengage power takeoff (PTO) and place transmission in neutral before attempting to start engine.

Many varied objects, such as wire, cable, rope, or chains, can become entangled in the operating parts of the wood chipper. These items could then swing outside the housing at greater velocities than the tines. Such a situation is extremely hazardous. Inspect the cutting area for such objects before working. Remove any like objects from the site.

Never allow the mowing tines to contact such items. Never assume an area is clear. **Always Check!**

Always stop the tractor, disengage PTO, set brake, shut off the tractor engine, remove the ignition key, lower implement to the ground and allow rotating pieces to come to a complete stop before dismounting tractor. Never leave equipment unattended with the tractor running.

Never place hands or feet under wood chipper with tractor engine running or before you are sure all motion has stopped. Stay clear of all moving parts.

SAFETY TRAINING

Do not reach or place any part of your body under equipment until it is blocked securely.

Do not allow riders on the rotary wood chipper or tractor at anytime. There is no safe place for any riders.

Do not operate unless all personnel, livestock, and pets are several hundred feet away to prevent injury by thrown objects.

Never operate tractor and rotary wood chipper under trees with low hanging limbs. Operators can be knocked off the tractor and then run over by the rotating tines.

The rotating parts of this machine have been designed and tested for rugged use. However, they could fail upon impact with heavy, solid objects such as steel guardrails and concrete abutment. Such impact could cause the broken objects to be thrown outward at very high velocities. To reduce the possibility of property damage, serious injury, or even death, Never allow the mowing tines to contact such obstacles.

Stop rotary wood chipper and tractor immediately upon striking an obstruction. Turn engine off, remove key, inspect and repair any damage before resuming operation.

Stay alert for uneven terrain, holes, rocks, and roots and other hidden hazards. Keep away from drop-offs and hazards that could cause roll over. Use extreme care and maintain minimum ground speed when trans-ported or operating on hillsides, over rough ground and when operating close to ditches or fences. Be careful and slow down when turning sharp corners and changing direction

SAFETY TRAINING

on slopes. Do not start or stop suddenly on slopes. Avoid operation on steep slopes. In extremely uneven terrain, rear wheels weights, front tractor weight, and/or tire ballast should be used to improve stability.

Pass rotary wood chipper diagonally through sharp dips and avoid sharp drops to prevent "hanging up" tractor and rotary wood chipper. Practice will improve your skills in maneuvering on rough terrain. Always cut down slopes, never across the face. Always check tractor manual for proper use on slopes.

When using a unit, a minimum 20% of tractor and equipment weight must be on tractor front wheels. Without this weight, tractor could tip over, causing personal injury or death. The weight may be attained with a front-end loader, front wheel weights, ballast in the tires or front tractor weights. When attaining a minimum 20% of tractor and equipment weight on the front wheels, you must not exceed the ROPS weight certification. Weigh the tractor and equipment. **Do not guess or estimate!**

TRANSPORT SAFETY

Comply with state and local laws governing highway safety and movement of farm machinery on public roads.

The use of flashing amber lights is acceptable in most localities. However, some localities prohibit their use. Local laws should be checked for all lighting and marking requirements.

At all times, when driving the tractor and equipment on the road or highway under 20 m.p.h. (32kph) use flashing amber warning lights and a slow moving vehicle (SMV) identification emblem. Do not exceed 20 m.p.h. (32 kph).

SAFETY TRAINING

Reduce speed on rough roads and surfaces.

Plan your route to avoid heavy traffic.

Always install transport locks, pins or brackets before transporting.

Do not drink and drive.

Be a safe and courteous driver. Always yield to oncoming traffic in all situations, including narrow bridges, intersections, etc. Watch for traffic when operating near or crossing roadways.

Turn curves or go up or down hills only at a low speed and at a gradual steering angle. Make certain that a least 20% of the tractor's weight is on the front wheels to maintain safe steering. Slow down on rough or uneven surface. Always check tractor manual for proper use on slopes.

Use extreme care and maintain minimum ground and when operating close to ditches or fences. Be careful when turning sharp corners.

Use extreme care and maintain minimum ground and when operating close to ditches or fences. Be careful when turning sharp corners.

Never allow riders on either tractor or wood chipper.

MAINTENANCE SAFETY

Good maintenance is your responsibility. Poor maintenance is an invitation to trouble.

Follow good shop practices.

Keep service area clean and dry.

SAFETY TRAINING

Be sure electrical outlets and tools are properly grounded.

Use adequate light for the job at hand.

Make sure there is plenty ventilation. Never operate the engine of the towing vehicle in a closed building. The exhaust fumes may cause asphyxiation.

Before working on this machine, disengage the PTO, shut off the engine, set the brakes, and remove the ignition keys.

Be certain all moving parts on attachments have come to a complete stop before attempting to perform maintenance.

Never work under equipment unless it is blocked securely.

Always use personal protection devices such as eye, hand and hearing protectors, when performing any service or maintenance.

Frequently check wood chipper tines. They should be sharp, free of nicks and cracks and securely fastened.

Periodically tighten all bolts, nuts, and screws and check that all cotter pins are properly installed to ensure unit is in safe condition.

When completing a maintenance or service function, make sure all safety shields and devices are installed before placing unit in service.

After servicing, be sure all tools, parts and service equipment are removed from wood chipper.

SAFETY TRAINING

Do not allow debris, grease or oil to build up on any deck or platform.

Where replacement parts are necessary for periodic maintenance and servicing, genuine factory replacement parts must be used to restore your equipment to original specifications.

The manufacturer will not be responsible for injuries or damages caused by use of unapproved parts and/or accessories.

A fire extinguisher and the first aid kit should be kept readily accessible while performing maintenance on this equipment.

STORAGE SAFETY

Following operation, or when unhooking the wood chipper, stop the tractor, set the brakes, disengage the PTO, shut off the engine and remove the ignition keys.

Store the unit in an area away from human activity.

Do not park equipment where it can be exposed to direct contact to livestock for long periods of time. Damage and livestock injury could result.

Make sure all parked machines are on a hard, level surface and engage all safety devices.

SAFETY TRAINING

Do not allow debris, grease or oil to build up on any deck or platform.

Where replacement parts are necessary for periodic maintenance and servicing, genuine factory replacement parts must be used to restore your equipment to original specifications.

The manufacturer will not be responsible for injuries or damages caused by use of unapproved parts and/or accessories.

A fire extinguisher and the first aid kit should be kept readily accessible while performing maintenance on this equipment.

STORAGE SAFETY

Following operation, or when unhooking the wood chipper, stop the tractor, set the brakes, disengage the PTO, shut off the engine and remove the ignition keys.

Store the unit in an area away from human activity.

Do not park equipment where it can be exposed to direct contact to livestock for long periods of time. Damage and livestock injury could result.

Make sure all parked machines are on a hard, level surface and engage all safety devices.

ASSEMBLE INSTRUCTION

The machine comes from the factory in a shipping configuration. Always use tools equipment and forklifts of appropriate size and capacity for the job. Always use 2 men when lifting, moving and assembling the machine.

When the machine is shipped, follow this procedure when preparing for the customer:

1. Clear the area of bystanders especially small children before starting.
2. Use a forklift to lift the pallet/machine from the truck. Carry the load close to the ground.
3. Move the machine to the assembly area. Be sure there is sufficient clearance to access the machine from all sides.

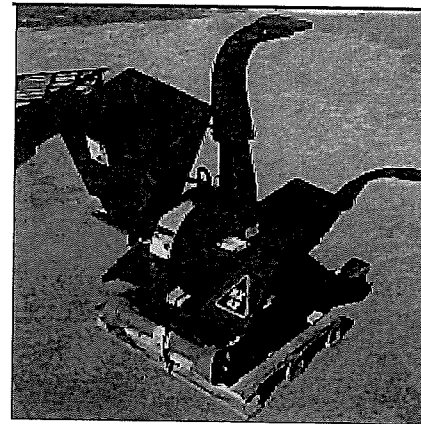

BX42

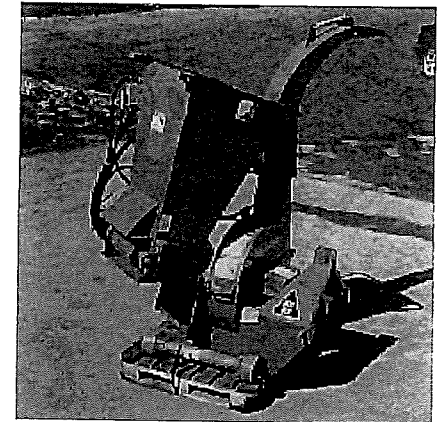

BX62R

ASEMBLE INSTRUCTION

4. Lay-out components next to machine.

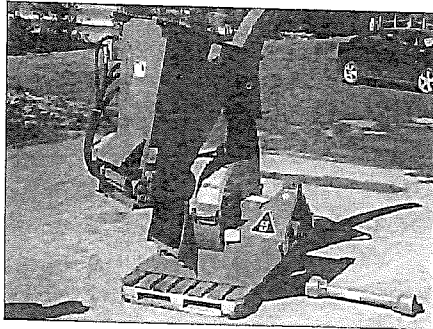

BX62R

5. Use a forklift to raise and lift the frame.

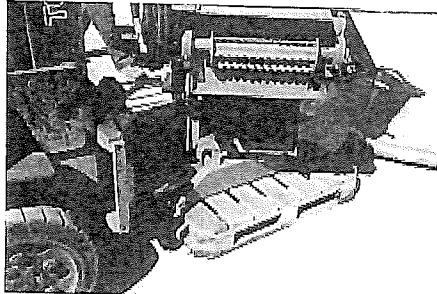

6. Or alternatively attach a lifting device to the lifting bracket on top of the frame.

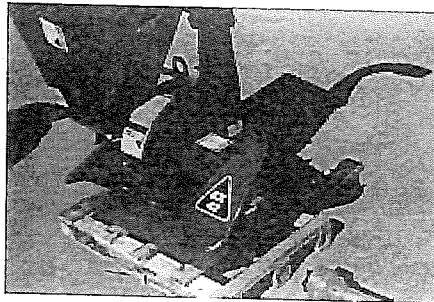

ASEMBLE INSTRUCTION

7. Remove pallet and place machine on the ground.

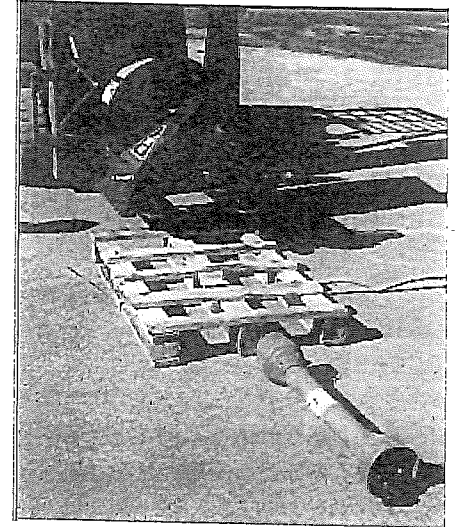

8. Release feed hopper transport latch and lower hopper into the working position. Stow anchor latch.

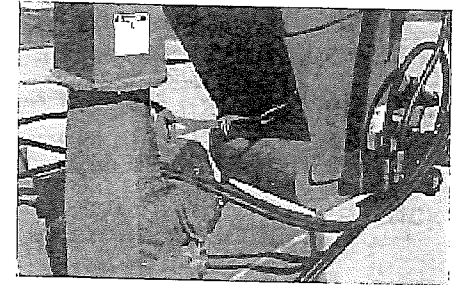

9. Tighten anchor bolts to their specified torque.

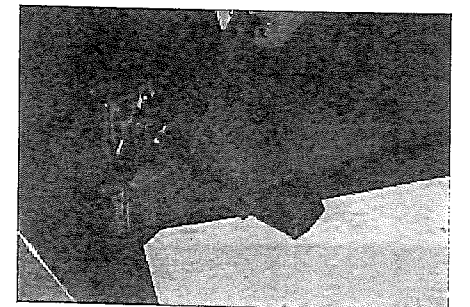

ASSEMBLE INSTRUCTION

10. Connect the PTO driveline:

1. Raise the input shaft guard.

2. Check that the driveline telescopes easily and that the shield rotates freely.

3. Attach the driveline to the chipper input shaft by depressing the lock pin, slide yoke over the shaft and pushing on the yoke until the lock pin clicks into position.

NOTE

Be sure the yoke with the shear pin is attached to the machine shaft.

4. Lower the guard to cover the input shaft.

11. Depress handle on discharge chute latch and turn assembly to its desired position. Turn until latch seats in its detent.

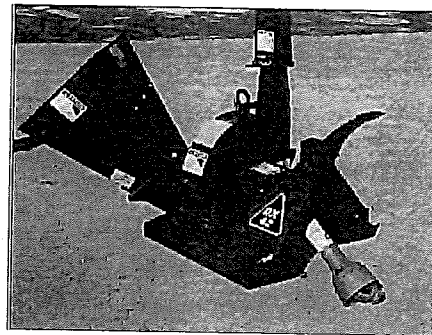
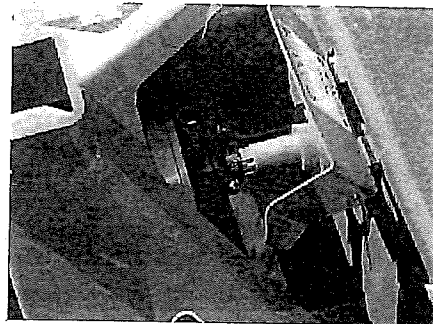

OPERATION



OPERATING SAFETY

1. Please remember it is important that you read the operator's manual and heed the safety signs on the 3 Point Hitch Wood Chipper. They are there for your safety, as well as the safety of others. The safe use of this machine is strictly up to you, the operator.

2. Personal protection equipment including hearing protection, hard hat, safety glasses, safety shoes, and gloves are recommended during assembly, installation, operation, adjustment, maintaining, repairing, or plugging. Do not allow long hair, loose-fitting clothing, or jewellery to be around moving parts.

3. Turn machine off, stop and disable engine, remove ignition key and place in your pocket, set park brake and wait for all moving parts to stop before servicing, adjusting, repairing or unplugging.

4. Do not run machine inside a closed building to prevent asphyxiation from engine exhaust.

5. Use care when feeding material into chipper.

6. Do not send metal, bottles, cans, rocks, glass or other foreign material into wood chipper. If foreign material enters chipper, stop machine, turn engine off and place ignition key in your pocket and wait for all moving parts to stop before removing material and/or unplugging. Inspect machine for damaged or loose parts before resuming work.

7. Never use alcoholic beverages or drugs which can

OPERATION

hinder alertness or coordination while operating this equipment. Consult your doctor about operating this machine while taking prescription medications.

8. Do not allow riders on this machine at any time. There is no safe place for any riders.

9. Never allow children or unauthorized people to operate or be around this machine.

10. Do not reach into rotor or feed hopper openings when the engine is running. Install and secure access covers before starting engine.

11. Do not move or transport chipper when the rotor is turning.

12. Do not exceed a safe travel speed when transporting.

13. Keep hydraulic lines and fittings tight, in good condition and free of leaks.

14. Keep the working area clean and free of debris to prevent tripping. Operate only on level ground.

15. Do not point discharge at people, animals or buildings. Rotor can expel wood chips fast enough to cause injury.

OPERATION

TO THE NEW OPERATOR OR OWNER

1. The Bowell 3 Point Hitch Wood Chippers are designed to chip or chop scrap lumber, small trees, brush, limbs and other wood debris. The chipped material is fine enough to be composted or used in a variety of ways.

2. It is the responsibility of the owner or operator to read this manual and to train all other operators before they start working with the machine. Follow all safety instructions exactly. Safety is everyone's business. By following recommended procedures, a safe working environment is provided for the operator, bystanders and the area around the worksite. Untrained operators are not qualified to use the machine.

3. Follow all safety instructions exactly. Safety is everyone's business. By following recommended procedures, a safe working environment is provided for the operator, bystanders and the area around the worksite. Untrained operators are not qualified to operate the machine.

4. Many features incorporated into this machine are the result of suggestions made by customers like you. Read this manual carefully to learn how to use the chipper safely and how to set it to provide maximum field efficiency. By following the using instructions in conjunction with a good maintenance program, your 3 Point Hitch Wood Chipper will provide many years of trouble-free service.

OPERATION

MACHINE COMPONENTS

The Bowell 3 Point Hitch Wood Chipper is a rotor with blades for chipping wood. A hinged feed hopper moves the wood material into the rotor.

Each rotor is designed with 4 blades and a twig-breaker to generate the small pieces of wood. A stationary knife at the rear of the rotor housing is placed by the moving knives to shear, chip or chop the material.

- A Manual Feed Hopper
- B Discharge Hood
- C Rotor Housing
- D Rotor Blade
- E Stationary Blade
- F Twig Breaker
- G Hood Deflector
- H Hydraulic Feed Hopper
- J Hydraulic Feed Control
- K Hydraulic Motor
- L PTO Driveline
- M Rotor
- N Paddle
- O 3 Point Hitch

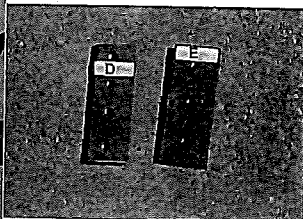
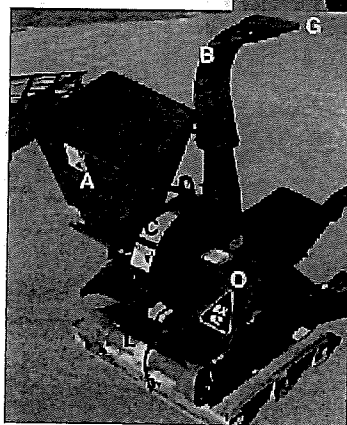
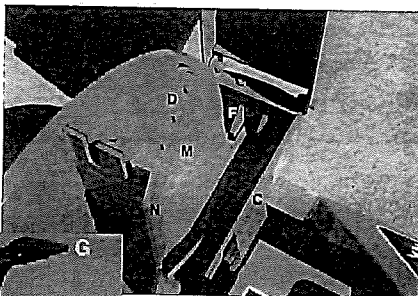
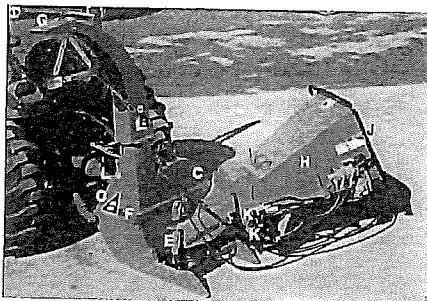

OPERATION

MACHINE BREAK-IN

Although there are no operational restrictions on the Wood Chipper when used for the first time, it is recommended that the following mechanical items be checked:

- A. After operating for 1 hour:
 1. Torque all fasteners and hardware.
 2. Check condition of rotor bearings.
 3. Check the condition and clearance of the twig-breaker, rotor and stationary blades. Adjust or replace as required.
 4. Check for entangled material. Remove all entangled material before resuming work.
 5. Lubricate all grease fittings.
- B. After operating for 10 hours:
 1. Repeat steps 1 through 5 listed above. (Section A)
 2. Go to the normal servicing and maintenance schedule as defined in the Maintenance Section.

PRE-OPERATION CHECKLIST

Efficient and safe operation of the Bowell 3 Point Hitch Wood Chipper requires that each operator reads and understands the using procedures and all related safety precautions outlined in this section. A pre-operation checklist is provided for the operator. It is important for both the

personal safety and maintaining good mechanical condition that this checklist is followed.

Before operating the Wood Chipper and each time thereafter, the following areas should be checked off:

1. Lubricate the machine per the schedule out-line in

OPERATION

the Maintenance Section.

2. Check the rotor, blades and twig-breaker. Remove any twine, wire or other material that has become entangled.

3. Check the condition and clearance of the twig-breaker, rotor and stationary blades. Adjust or replace as required.

4. Check that all bearings turn freely. Replace any that are rough or seized.

5. Make sure that all guards and shields are in place, secured and functioning as designed.

6. Check the condition of the curtain in the feed hopper. It must be in good condition to prevent chips from flying out.

OPERATION

DRIVELINE DIMENSION

A PTO driveline is supplied with the machine. To accompany the variety of 3 point hitch geometry available today, the driveline can be too long for most machines or too short for others. It is very important that the driveline be free to telescope but not to bottom out when going through its working range. If the driveline bottoms out, the bearings on both the machine and tractor PTO shaft will be overloaded and fail in a short time.

1. To determine the proper length of the driveline, follow this procedure:

a. Clear the area of bystanders, especially small children.

b. Attach the chipper to the tractor but do not attach the driveline.

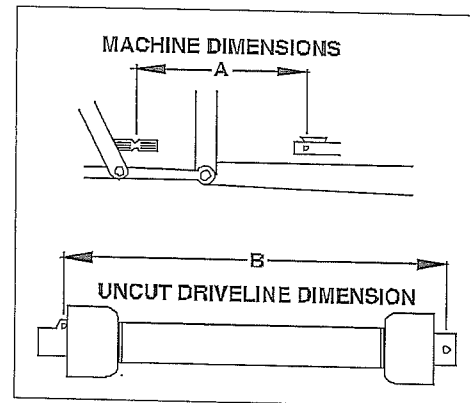

DRIVELINE DIMENSIONS

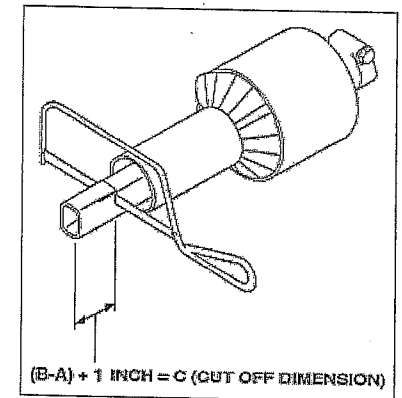

CUT OFF DIMENSION

c. Raise the machine until the input shaft is level with the tractor PTO shaft.

d. Measure the dimension between the locking grooves on the tractor PTO shaft and the machine input shaft. Measure the same dimensions on the compressed

OPERATION

driveline.

e.If the compressed driveline dimension exceeds the machine dimension, the driveline will have to be cut.

2.When cutting the driveline, follow this procedure:

a.Subtract the machine dimension (A) from the uncut driveline dimension (B) or (B-A). This dimension determines how much too long the driveline is.

b.Add another inch (25 mm) to the dimension to be sure it doesn't bottom out, to determine (C) the cut off dimension.

c.Use a hacksaw to cut dimension (C) from both ends. Cut both the plastic tubes and the metal cores.

d.Use a file to remove the burrs from the edges that were cut.

e.Assemble the 2 ends of the shaft.

f.Make sure the shaft can telescope freely. If it does not, separate the 2 parts and inspect for burrs or cuttings on the shaft ends. Be sure it telescopes freely before installing.

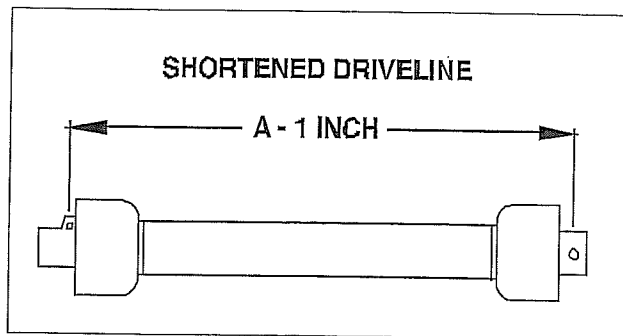

SHORTENING

OPERATION

MOUNTING AND UNHOOKING TRACTOR

When attaching chipper to a tractor, follow this procedure:

1.Clear the area of bystanders, especially small children.

2.Make sure there is enough room and clearance to safely back up to the chipper.

3.Place the tractor arms in their full sway position.

4.Back up slowly and align the lower link arms to the pins on the machine.

5.Mounting without a Quick Hitch

a.Align the left lower link with the left chipper pin.

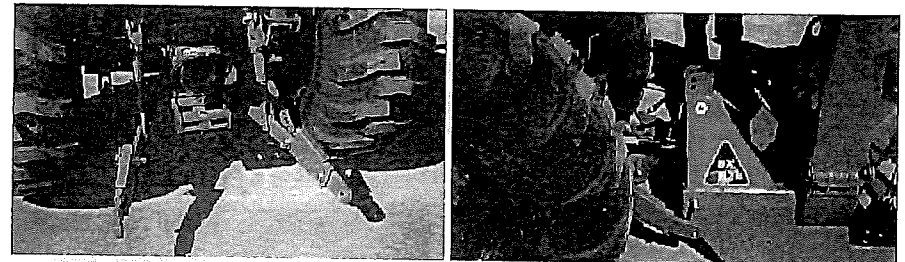

TRACTOR LOWER LINKS

Aligned

IMPORTANT

It may be necessary to add weight to the lower lift arms to bring them to the required height.

b.Insert the left pin through the ball and install the retainer.

c.Align the right arm to the pin by turning the jackscrew on the arm.

d.Insert the right pin through the ball and install the retainer. Return the jack-screw to its starting position.

e.Remove the top pin and install the top link. Use the turnbuckle to align the top link. Insert the pins and install the retainers. Return the turnbuckle to its original length and lock.

OPERATION

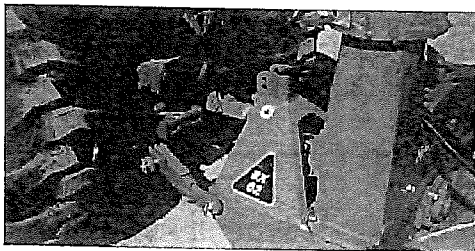

Pinned

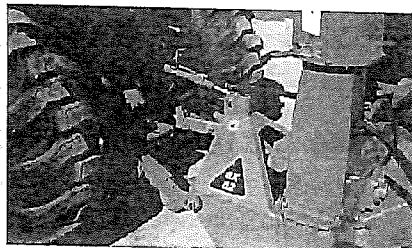

TOP LINK

6. Mounting with a Quick Hitch.

a. Align the claws on the Quick Hitch slightly below the mounting pins on the chipper.

IMPORTANT

It may be necessary to add weight to the lower lift arms to bring them to the required height.

b. Back up until the pins are above the claws.

c. Use the turnbuckle on the top link to adjust the position of the top claw.

d. Raise the 3 point hitch until the pins seat in the claws.

e. Be sure the retainers are released to hold the pins in the claws.

7. Set the 3 point hitch in the non-sway position (see tractor manual for details).

8. Install the PTO driveline:

NOTE

Be sure the telescoping portion of the shaft is greased and free of dirt.

a. Slide the collar back on the yoke, align the splines and slide the yoke on the tractor.

b. Release the collar and make sure the locking pin

OPERATION

clicks into position.

NOTE

The driveline should already have been cut to the required length.

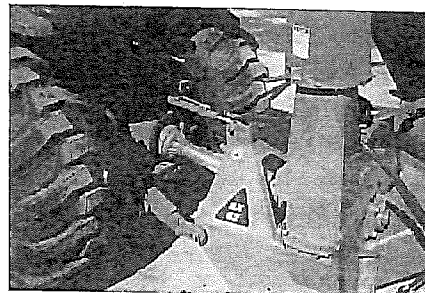

PTO SHAFT

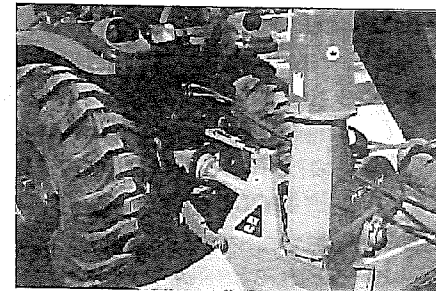

HYDRAULICS

9. Connect the hydraulics:

a. Use a clean rag or paper towel to clean the dirt from the couplers on the hose ends and the tractor.

b. Connect the hoses to the tractor couplers. Be sure the couplers are securely seated.

c. Route and secure the hoses along the hitch with clips, tape or plastic ties to prevent binding and pinching. Be sure to provide slack for turning.

NOTE

Always connect to the hydraulic circuit with a detent.

| WARNING | |
|---|---|
|  |  |
| HIGH PRESSURE FLUID HAZARD To prevent serious injury or death from high-pressure fluid: | |
| • Relieve pressure on system before repairing or adjusting. | |
| • Wear proper hand and eye protection when searching for leaks. Use wood or cardboard instead of hands. | |
| • Keep all components in good repair. | |

OPERATION

10. Slowly raise the machine through its working range to make sure the telescoping portion of the PTO shaft doesn't bottom out.

11. Level the machine front and rear, and side to side using the jackscrew on the right arm and the turnbuckle on the top link. The chipper should always be level on the ground in its working position.

12. To unhook from the tractor, reverse the above procedure. Always park the machine in a dry, level area. If vandalism is a problem, remove the PTO driveline and store in a secure place.

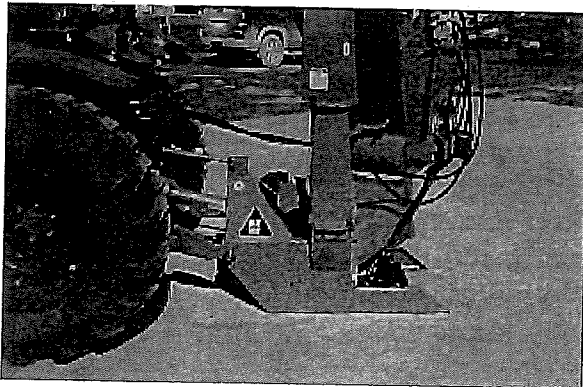

LEVELLING ADJUSTMENTS

OPERATION

CONTROLS

All controls are conveniently positioned next to where the operator would stand when feeding the machine to provide easy operation. Review this section to familiarize yourself with the location and function of each control before starting.

1. Hydraulic Feed Control Lever:

This lever is positioned to extend around the feed hopper and provides access from all sides. It is only available when the chipper is equipped with the optional hydraulic feed hopper.

Pull the control all the way out to engage the feeding system. Push in slightly to the first detent to stop the feeding system. Push the control all the way in to reverse the feeding system.

NOTE

Use the typical flow divider next to the control valve to set the feeding spread.

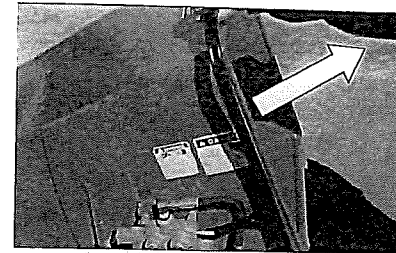

Feeding

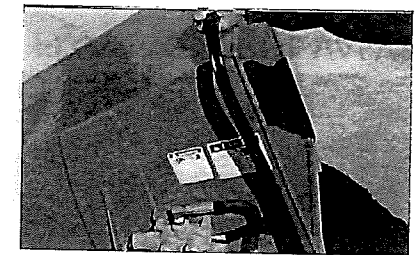

Neutral/Stop

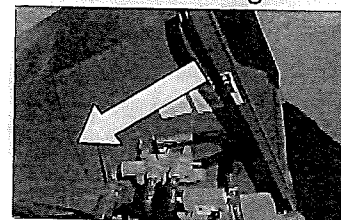

Reversing

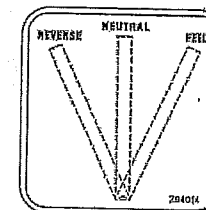

Left side

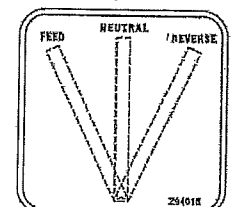

Right side

OPERATION

2. Deflector Position:

Each discharge hood is equipped with a deflector on the end to place the chips exactly where desired. There are 2 types available:

a. Manual Clamp (BX42):

The deflector is held in place by clamping bolts on each side. Loosen the clamps, move the deflector and tighten the clamps. Position as desired.

b. Spring-Loaded (Bx62):

The deflector is spring-loaded up and held in place by a chain. Release the chain from its anchor bracket and move the deflector to its desired position. Secure chain in its anchor bracket.

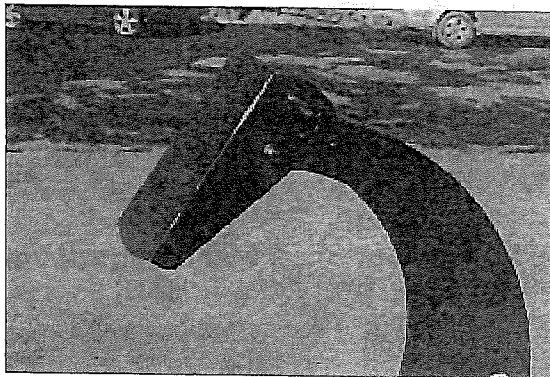

Manual Clamp

3. PTO Control:

If you are not familiar with the location of the PTO control on your tractor, review your tractor's Operator's Manual. Always engage the PTO control slowly when the engine is running at low idle RPM. Disengage the PTO control slowly at low RPM to allow the machine to slow and stop before engaging the PTO brake. Remember the PTO drives the rotor. When the PTO is engaged the rotor will also start to turn.

OPERATION

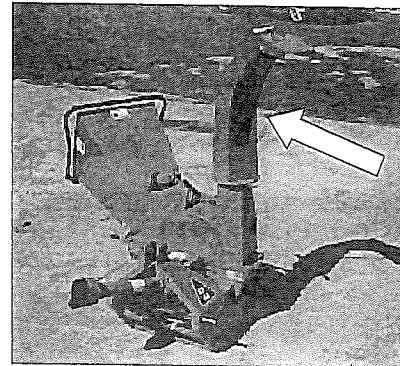

Spring-Loaded

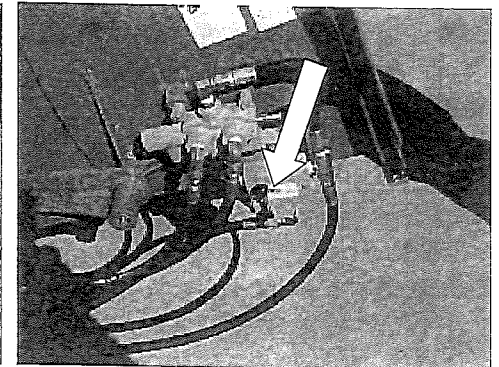

FLOW CONTROL VALVE

4. Flow Control Valve:

This manually-set flow divider allows the operator to set the flow through the circuit from 0% to 100% by dumping the excess flow back to the tractor. A scale on the face of the valve is numbered from 0 to 10 to define the percent of flow from 0 to 100% flowing into the circuit. The hydraulic feed circuit is equipped with a flow divider so the operator can adjust the feeding speed appropriate for the operating conditions. Loosen the lock and move the pointer arm to the desired position. Tighten the lock bolt. Adjust in small increments as a small change can result in a large change to feeding speed.

OPERATION

FIELD OPERATION OPERATION SAFETY

Please remember it is important that you read the operator's manual and heed the safety signs on the 3 Point Hitch Wood Chipper. They are there for your safety, as well as the safety of others. The safe use of this machine is strictly up to you, the operator.

Personal protection equipment including hearing protection, hard hat, safety glasses, safety shoes, and gloves are recommended during assembly, installation, operation, adjustment, maintaining, repairing, or plugging. Do not allow long hair, loose-fitting clothing, or jewellery to be around moving parts.

Turn machine off, stop and disable engine, remove ignition key and place in your pocket, set park brake and wait for all moving parts to stop before servicing, adjusting, repairing or unplugging.

Do not run machine inside a closed building to prevent asphyxiation from engine exhaust.

Use care when feeding material into chipper. Do not send metal, bottles, cans, rocks, glass or other foreign material into wood chipper. If foreign material enters chipper, stop machine, turn engine off and place ignition key in your pocket and wait for all moving parts to stop before removing material and/or unplugging. Inspect machine for damaged or loose parts before resuming work.

Never use alcoholic beverages or drugs which can hinder alertness or coordination while operating this equipment. Consult your doctor about operating this

OPERATION

machine while taking prescription medications.

Do not allow riders on this machine at any time. There is no safe place for any riders.

Never allow children or unauthorized people to operate or be around this machine.

Do not reach into rotor or feed hopper openings when the engine is running. Install and secure access covers before starting engine.

Do not move or transport chipper when the rotor is turning.

Do not exceed a safe travel speed when transporting.

Keep hydraulic lines and fittings tight, in good condition and free of leaks.

Keep the working area clean and free of debris to prevent tripping. Operate only on level ground.

Do not point discharge at people, animals or buildings. Rotor can expel wood chips fast enough to cause injury.

OPERATION

Although the 3 Point Hitch Wood Chipper is easy to use, each operator should review this section to familiarize himself with the detailed safety and operating procedures. When using this machine, follow this procedure:

1. Clear the area of bystanders, especially small children.

2. Review and follow the Pre-Operation Check-list.

3. Attach the machine to the tractor.

4. Drive to the work area and position at the worksite.

5. Set park brake.

6. Stop engine.

7. Remove ignition key and place in your pocket.

8. Move the feed hopper down into its working configuration and secure with the anchor nuts.

9. Turn discharge hood to its working position.

10. Starting the Machine:

a. Start the tractor engine.

b. Move the throttle to its low idle position.

c. With the engine at low idle, slowly engage the PTO

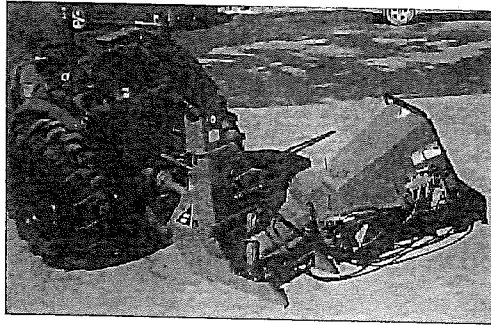

FEED HOPPER/
DISCHARGE HOOD

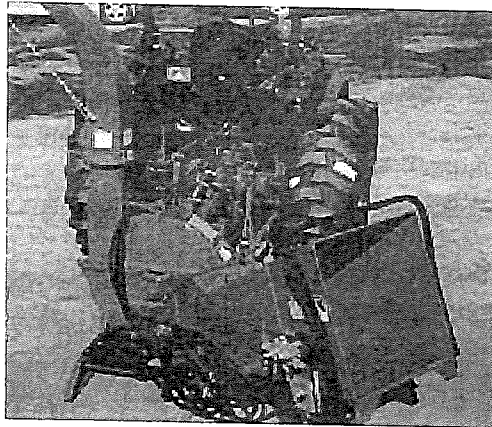

Hydraulic Feed

OPERATION

control.

d. Slowly increase the engine speed until the PTO is at rated speed.

e. With the manual feeding model, start feeding material into the hopper.

f. With the hydraulic feeding model:

Place the tractor hydraulic lever into its detent position.

Move the control lever into the feed position.

1 Start feeding material into the hopper.

11. Stopping:

a. Stop feeding material into the hopper.

b. Place the hydraulic feed control in off/neutral.

c. Slow engine RPM.

d. Place hydraulic lever in its OFF position.

e. Disengage PTO.

f. Stop engine, remove ignition key and place in your pocket and wait for all moving parts to stop.

12. Emergency Stopping:

Stop tractor engine if an emergency occurs. Correct emergency situation before starting engine and resuming work.

13. Feeding:

a. Manual Feed:

Slowly slide the wooden material into the feed hopper and move it into the rotor.

Do not push the material with a lot of force into the rotor.

Do not push the material too fast into the rotor. Stop

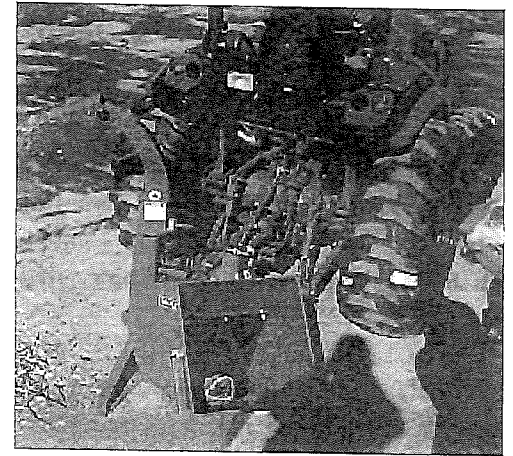

Working

OPERATION

and slow down if the engine starts to slow down.

Do not reach into the feed hopper further than the curtain to be sure not to contact the blades on the rotor.

Use a stick or branch to push any piece of material into the rotor that does not move on its own and stops in the hopper. Do not take a chance with getting your hand caught in the rotor.

b. Hydraulic Feed:

Slowly slide the wooden material into the feed hopper until the roller grabs the material and move it into the rotor.

Use the flow divider on the side of the feed hopper to set the feeding speed

Do not reach into the feed hopper further than the curtain to be sure not to contact the feed roller or the blades on the rotor.

Use a stick or branch to push any piece of material into the feed roller that does not move on its own and stops in the hopper. Do not take a chance with getting your hand caught in the feed roller.

14. Always wear personal protective equipment (PPE) whenever operating the machine. This includes but is not limited to protective shoes with slip resistant soles, protective goggles or face shield, heavy gloves, hearing protection and protective clothing.

15. Do not place metal, bottles, cans, rocks, glass or other solid material into the wood chipper. If something like this gets into the machine, stop the machine immediately for a detailed inspection. Stop engine, remove ignition key and place in your pocket and wait for all moving parts to stop before inspecting or unplugging. Inspect machine for damaged or loosened parts before resuming work.

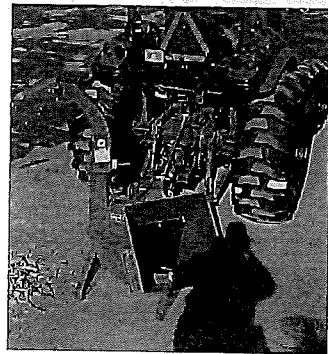

Operation

OPERATION

16. Blades:

There are 2 types of blades used on the Wood Chipper. They work together to cut, shear and shred the wood as it moves through the machine.

a. Rotor blades:

The rotor is equipped with 4 blades

s placed at 90° to each other to keep the rotor in balance. If one needs to be changed, the one opposite should be changed.

b. Stationary blade:

Each machine is equipped with a stationary blade that acts as a stop for the moving rotor blades.



WARNING

Machine is shown with guard opened or rotor cover opened for illustrative purposes only. Do not operate machine with guard opened or cover opened.



a. Rotor b. Stationary

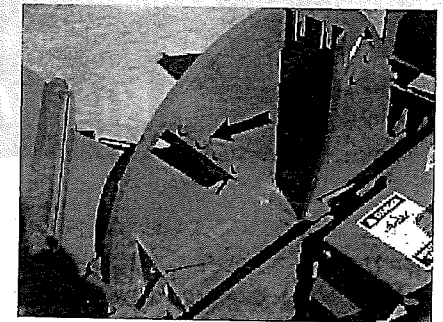

Rotor

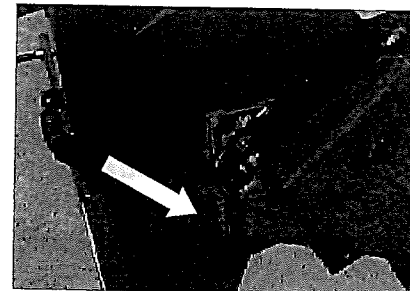

Stationary

OPERATION

17. Twig Breaker:

Each machine is equipped with a twig breaker to break up twigs or other long material as it moves through the rotor compartment. Open the rotor cover and check the condition of the breaker on a weekly basis. Also check for any entangled material when the rotor cover is opened. Remove this material prior to closing the cover and resuming work.



WARNING

Machine is shown with guard opened or rotor cover opened for illustrative purposes only. Do not operate machine with guard opened or cover opened.

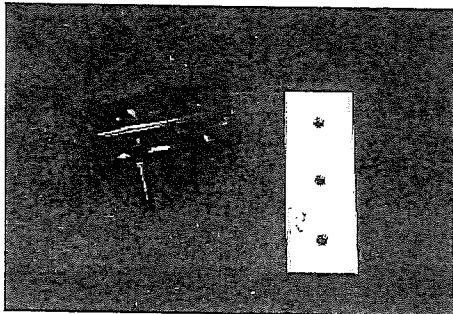

Disassembled

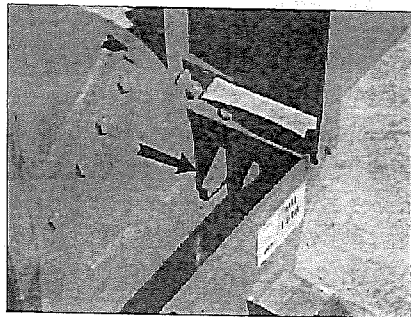

Double

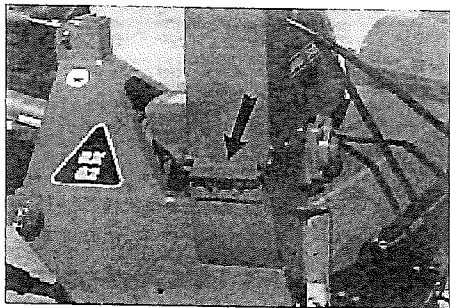

Mounting

OPERATION

18. Shear Pin:

The PTO driveline is designed with a shear pin at the input yoke to prevent overloading the drive system. Remove the broken parts from the yoke when the pin shears and replace with genuine **Bowell** parts. The drive system is designed to function well without failing the shear pin. If it does fail, generally it is being fed too fast or something very hard has been jammed into the rotor or between the blades. Always unplug the system and determine the cause of the problem and correct it before resuming work.



WARNING

Machine is shown with guard opened or rotor cover opened for illustrative purposes only. Do not operate machine with guard opened or cover opened.

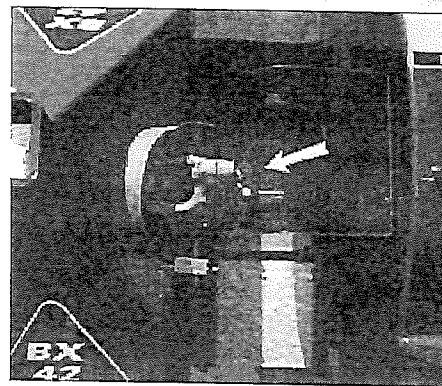

BX42

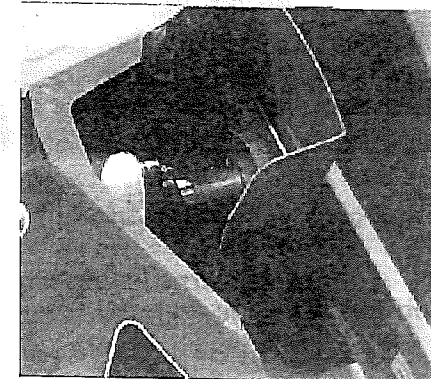

BX62R

19. Unplugging:

Although the machine is designed to handle a wide variety of material without any problem, occasionally it plugs. When the machine plugs, follow this procedure to

OPERATION

unplug:

a. Clear the area of bystanders, especially small children.

b. Stop the engine, remove the ignition key and place it in your pocket and wait for all moving parts to stop before unplugging.

c. Pull the material out of the feed hopper or reverse the hydraulic feed hopper. Be sure all the material is out and nothing is jammed or wedged between the input opening and the rotor.

d. Pull the material out of the discharge hood. Use a stick to poke loose any material jammed into the discharge hood. Do not allow anything to remain in this area.

e. Severe plug:

Loosen the feed hopper anchor nuts and raise the feed hopper. Remove material from inside the rotor compartment.

Clean out the discharge area/rotor.

Open the rotor cover and clean out the housing. Be sure to turn the rotor by hand to be sure there is nothing jammed between the rotor and stationary blades.

Close, install and fold down all components opened to unplug. Tighten fasteners to their specified torque.

f. Check that everyone is clear of machine before restarting engine.

g. Start the engine, engage the PTO and resume working.



WARNING

Machine is shown with guard opened or rotor cover opened for illustrative purposes only. Do not operate machine with guard opened or cover opened.

OPERATION

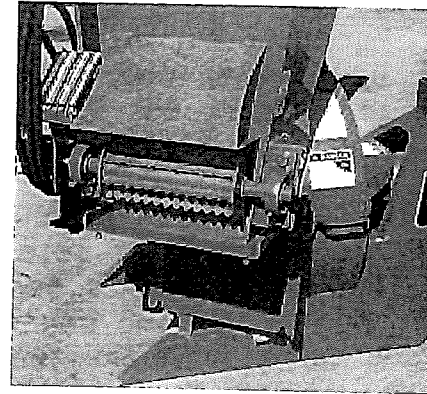

Feed Hopper

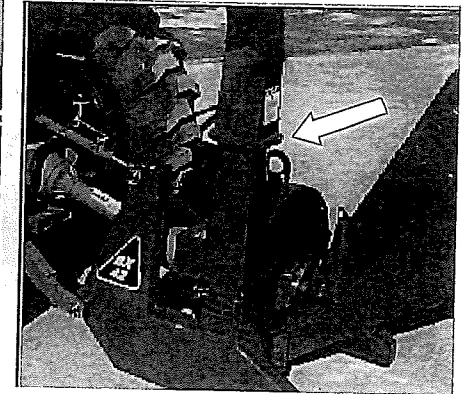

Discharge Hood

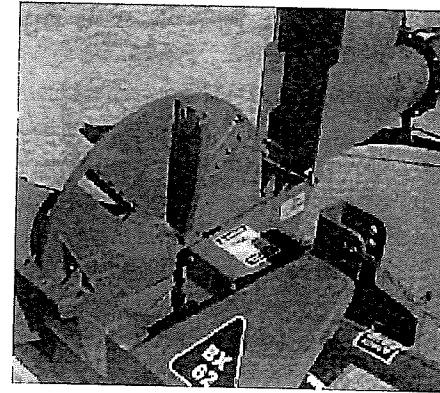

Rotor Cover

20. Cleaning:

Clean the machine frequently to prevent a build-up of dust, chips and trash on the frame. A clean machine reduces the chance of rusting.

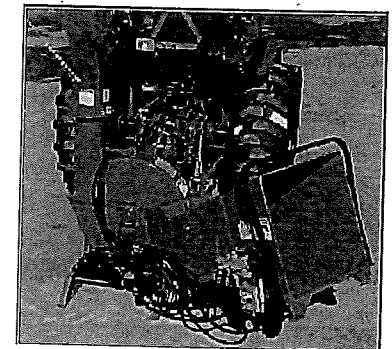

Cleaning

OPERATION

21. Curtains:

Each feed hopper is designed with an internal rubber/belting curtain to prevent chips and debris from coming out of the hopper when working. Check the condition of the curtain each day prior to starting. Replace the curtain if torn, damaged or missing to minimize the chance of material coming out of the feed hopper.

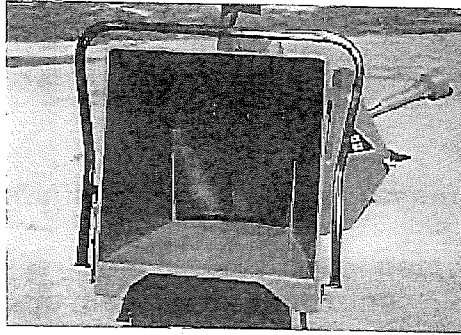

CURTAIN BX62

22. Sharpening Blades:

The rotor and stationary blades need to be sharp for the chipper to perform as expected. It is recommended that the rotor blades be removed from the rotor when sharpening. Always sharpen the blades at a 45° angle to provide the best cutting effect as it meets the stationary blade. Be sure to tighten the blade mounting bolts to their specified torque when re-installing the blades to the rotor. The stationary blade is designed with 4 sharp corners that can be utilized. When the corner facing the rotor blade rounds over, remove the blade and re-install with a different corner facing the rotor blade. Use the stationary blade to set the clearance to the rotor blade when re-installing. Be sure to tighten mounting bolts to their specified torque.

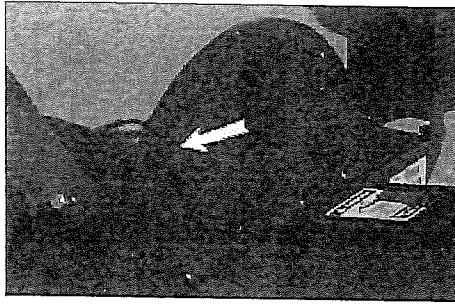

BX42

OPERATION

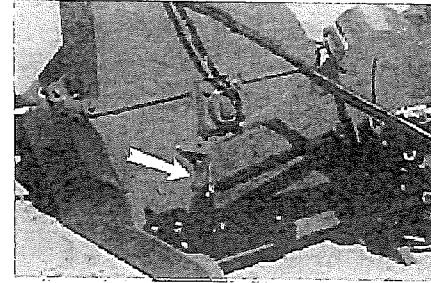

Stationary

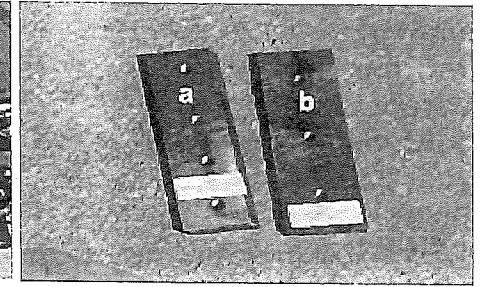

A Rotor

B Stationary

23. Hydraulic Feed Control:

The machine with the hydraulic feed hopper is designed with a control lever to place the hopper in FEED - OFF/NEUTRAL - REVERSE. Pull all the way out to feed, push in to the first detent for off or neutral and fully in for reverse. In reverse the material in the hopper is pulled out of the rotor. Use reverse when the rotor is overloaded, jammed or plugged.

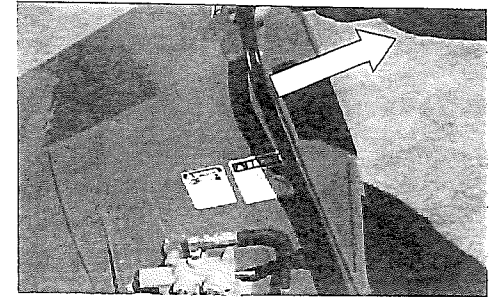

Feeding

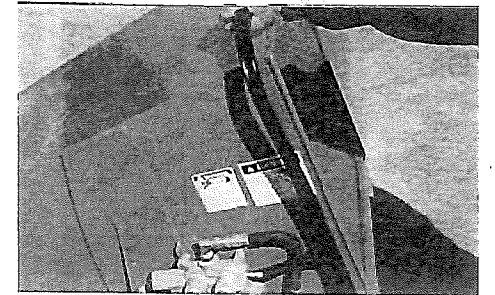

Neutral/Stop

IMPORTANT

Check the function of the control lever when attaching the hydraulic lines to the tractor. The hopper must feed in when the lever is moved out. If it does not, reverse the hoses. **The control lever must**

OPERATION

function like the drawing on each side of the hopper or the hoses must be reversed.

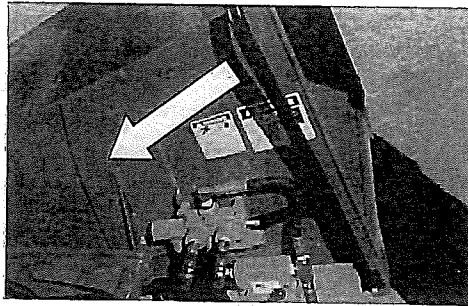

Reversing

Use the flow divider valve to set the speed of the feed hopper. Use the quality of the job being done to establish the required feed speed. Increase the speed when chipping brush or twigs. Decrease the speed when chipping hard, solid material or when the engine is being pulled down.

24. Personal Protective Equipment (PPE):

Each person must wear appropriate personal protective equipment whenever operating the chipper or working in the vicinity. This equipment is designed to prevent injury to any personnel in the area. This list includes but is not limited to:

- Safety shoes with slip resistant soles.
- Safety goggles or face shield.
- Hearing protection.
- Heavy or leather gloves.

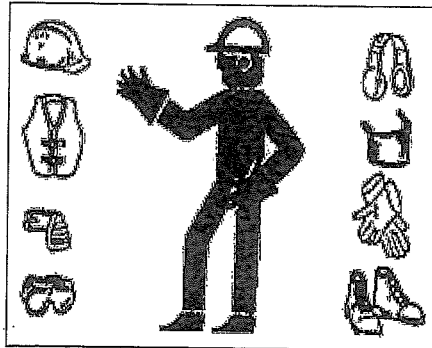

PERSONAL PROTECTIVE EQUIPMENT

25. Operating Hints:

OPERATION

a. Keep the working area clean and free of debris to prevent slipping or tripping. Operate only on level ground.

b. Do not place hands or any body parts into the feed hopper during operation. Use a stick or branch to push material into the rotor when it goes past the curtain in the feed hopper.

c. Do not point discharge at people, animals or buildings. Rotor can expel wood chips fast enough to cause injury.

d. Use care when feeding material into the chipper. Do not send metal, bottles, cans, rocks, glass or other foreign material into the wood chipper.

e. If foreign material enters chipper, stop machine, turn engine off and place ignition key in your pocket and wait for all moving parts to stop before removing material and/or unplugging. Inspect machine for damaged or loose parts before resuming work.

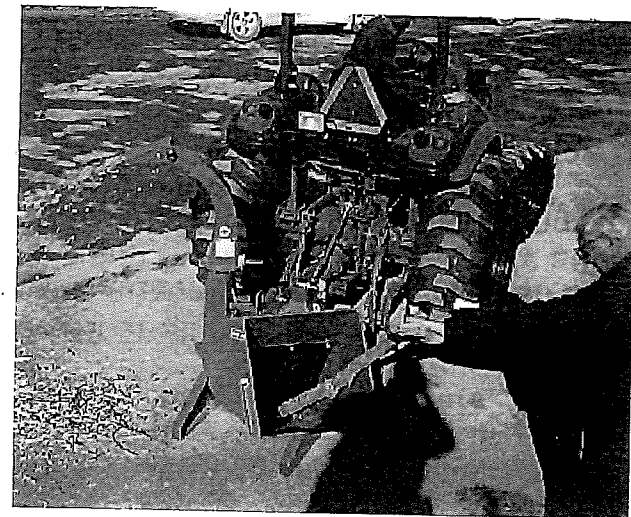

Working

TRANSPORTING

OPERATING SAFETY

1. Comply with state and local laws governing safety and transporting of machinery on public roads.
2. Check that all the lights, reflectors and other lighting requirements are installed and in good working condition.
3. Do not exceed a safe travel speed. Slow down for rough terrain and cornering..
4. Fold up and secure feed hopper before moving or transporting.
5. Be sure the trailer is hitched positively to the towing vehicle and a retainer is used through the mounting pins.
6. Do not drink and drive.
7. Be a safe and courteous driver. Always yield to oncoming traffic in all situations, including narrow bridges, intersections, etc. Watch for traffic when operating near or crossing roadways.
8. Never allow riders on the machine.



TRANSPORTING

- a. When transporting the machine, review and follow these instructions:
 - b. Clear the area of bystanders, especially small children.
 - c. Check that all the lights and reflectors required by the highway authorities are in place, clean and working.
 - d. Insure that the machine is securely attached to the tractor with a retainer through the mounting pins.
 - e. Do not allow riders.
 - f. Never exceed a safe travel speed. Slow down when encountering rough road conditions and cornering.
 - g. Do not drink and drive.
 - h. Raise and secure the feed hopper before transporting.

STORAGE

! OPERATING SAFETY

1. Store the unit in an area away from human activity.
2. Do not permit children to play on or around the stored machine.
3. Store the unit in a dry, level area. Support the frame with planks if required.

PLACING IN STORAGE

After the season's use or when the machine will not be used for a period of time, completely inspect all major systems of the 3 Point Hitch Wood Chipper. Replace or repair any worn or damaged components to prevent any unnecessary down time at the beginning of the next season.

Follow this procedure before storing:

1. Remove all material from the machine.
2. Thoroughly wash the machine with a pressure washer or water hose to remove all dirt, mud or debris.
3. Inspect all rotating parts for entangled material. Remove all entangled material.
4. Run the machine a few minutes to dry the moisture from inside the machine.
5. Move the feed hopper up and lock.
6. Touch up all paint nicks and scratches to prevent rusting.
7. It is best to store the machine inside. If that is not possible, cover with a waterproof tarpaulin and tie down securely.
8. Store in an area away from human activity.
9. Do not allow children to play around the stored unit.

REMOVING FROM STORAGE

STORAGE

When removing this machine from storage, follow this procedure:

1. Remove the tarpaulin if covered.
2. Review and follow the pre-operation checklist.



SERVICE AND MAINTENANCE



MAINTENANCE SAFETY

1. Good maintenance is your responsibility. Poor maintenance is an invitation to trouble.
2. Follow good shop practices.
 - Keep service area clean and dry.
 - Be sure electrical outlets and tools are properly grounded.
 - Use adequate light for the job at hand.
3. Make sure there is plenty of ventilation. Never operate the engine of the towing vehicle in a closed building. The exhaust fumes may cause asphyxiation.
4. Before working on this machine, shut off the engine, set the brake, and turn fuel valve off.
5. Never work under equipment unless it is blocked securely.
6. Always use personal protection devices such as eye, hand and hearing protectors, when performing any service or maintenance work. Use heavy gloves when handling sharp components.
7. A fire extinguisher and first aid kit should be kept readily accessible while performing maintenance on this equipment.
8. Periodically tighten all bolts, nuts and screws and check that all electrical and fuel connections are properly secured to ensure unit is in a safe condition.
9. When completing a maintenance or service function, make sure all safety shields and devices are installed before placing unit in service.

SERVICE

1. FLUIDS AND LUBRICANTS

Grease: Use an SAE multipurpose high temperature grease with extreme pressure (EP) performance. Also

SERVICE AND MAINTENANCE

acceptable is an SAE multipurpose lithium base grease.

Storing Lubricants: Your machine can operate at top efficiency only if clean lubricants are used. Use clean containers to handle all lubricants. Store them in an area protected from dust, moisture and other contaminants.

2. GREASING

Use the Maintenance Checklist provided to keep a record of all scheduled maintenance.

Use a hand-held grease gun for all greasing.

Wipe grease fitting with a clean cloth before greasing, to avoid injecting dirt and grit.

Replace and repair broken fittings immediately.

If fittings will not take grease, remove and clean thoroughly. Also clean lubricant passageway. Replace fittings if necessary.

SERVICE AND MAINTENANCE

SERVICING INTERVALS

The period recommended is based on normal operating conditions. Severe or unusual conditions may require more frequent lubrication or oil changes.

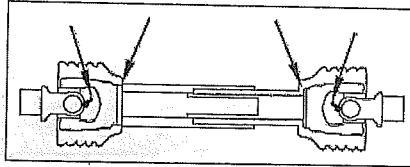

PTO driveline

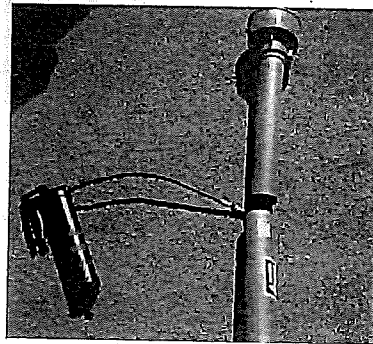

TELESCOPING SECTION

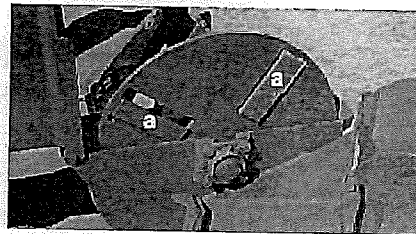

Rotor

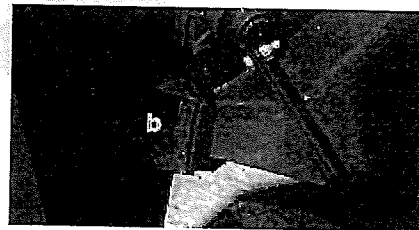

Stationary

8 Hours or Daily

1. Grease PTO driveline.

40 Hours or Weekly

1. Grease the telescoping section of the PTO shaft.

WARNING

Machine is shown with guard removed or rotor cover opened for illustrative purposes only. Do not operate machine with guard removed or cover opened.

2. Check sharpness of blades:

Rotor

Stationary

Remove, sharpen or switch edge as required.

SERVICE AND MAINTENANCE

100 Hours

1. Grease the hydraulic feed system:
 - a. Roller bearings.
 - b. Pivot bushing.

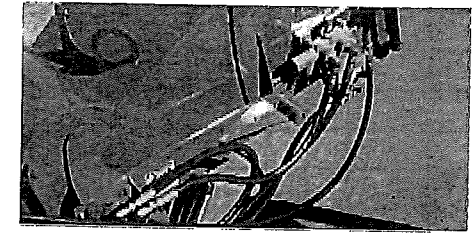

Left Side

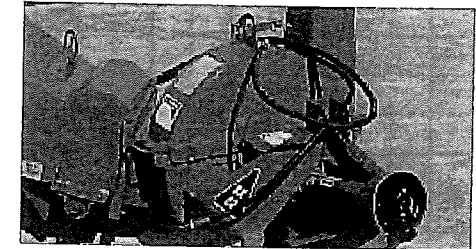

Right Side

2. Grease rotor bearings on BX42 and BX62 models.



Front

IMPORTANT

Do not over grease.

WARNING

Machine is shown with guard removed or rotor cover opened for illustrative purposes only. Do not operate machine with guard removed or cover opened.



Rear

SERVICE AND MAINTENANCE

Annually
1. Clean Machine

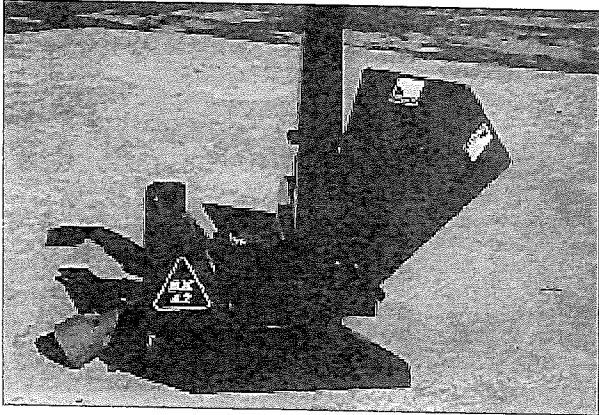

BX42

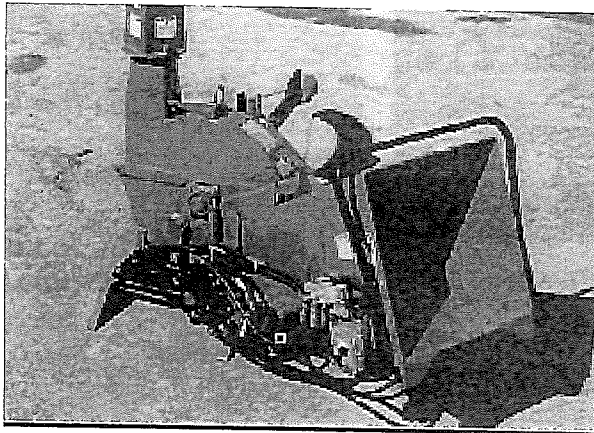

BX62

SERVICE AND MAINTENANCE

Service Record

See Lubrication and Maintenance sections for details or service. Copy this page to continue record.

| Hours Serviced By | | | | | | | | | | | | | | | | | | | | | |
|--------------------------------|--|--|--|--|--|--|--|--|--|--|--|--|--|--|--|--|--|--|--|--|--|
| Maintenance | | | | | | | | | | | | | | | | | | | | | |
| 8 hours or daily | | | | | | | | | | | | | | | | | | | | | |
| Grease PTO Driveline | | | | | | | | | | | | | | | | | | | | | |
| | | | | | | | | | | | | | | | | | | | | | |
| | | | | | | | | | | | | | | | | | | | | | |
| 40 hours or weekly | | | | | | | | | | | | | | | | | | | | | |
| Grease Telescoping Section PTO | | | | | | | | | | | | | | | | | | | | | |
| Check Blade Sharpness | | | | | | | | | | | | | | | | | | | | | |
| | | | | | | | | | | | | | | | | | | | | | |
| | | | | | | | | | | | | | | | | | | | | | |
| 100 hours or 6 months | | | | | | | | | | | | | | | | | | | | | |
| Grease Roller Bearings | | | | | | | | | | | | | | | | | | | | | |
| Grease Pivot Bearings | | | | | | | | | | | | | | | | | | | | | |
| Grease Rotor Bearings | | | | | | | | | | | | | | | | | | | | | |
| | | | | | | | | | | | | | | | | | | | | | |
| | | | | | | | | | | | | | | | | | | | | | |
| Annually | | | | | | | | | | | | | | | | | | | | | |
| Clean Machine | | | | | | | | | | | | | | | | | | | | | |
| | | | | | | | | | | | | | | | | | | | | | |
| | | | | | | | | | | | | | | | | | | | | | |
| | | | | | | | | | | | | | | | | | | | | | |

SERVICE AND MAINTENANCE

By following a careful service and maintenance program for your machine, you will enjoy many years of trouble-free operation.

DRIVELINE MAINTENANCE

The PTO driveline is designed to telescope to allow for dimensional changes as the machine goes through its operational range. A tubular guard encloses the driving components and is designed to turn relative to the driving components. The driveline should telescope easily and the guard turn freely on the shaft at all times. Annual disassembly, cleaning and lubrication is recommended to insure that all components function as intended. To maintain the driveline, follow this procedure:

1. Remove the driveline from the machine.
2. Pull driveline apart.
3. Use a screwdriver to turn lock studs on each end. There are 2 studs per guard..
4. Pull the shaft out of the plastic tubular guard.
5. Use a solvent to clean the male and female portions of the telescoping ends.
6. Apply a light coat of grease to each end.
7. Use a solvent to wash the grooves on each end where the studs are located. Clean each end also.
8. Apply a light coat of grease to each groove.
9. Insert the shaft into its respective guard and align the studs with the holes.
10. Insert the studs through the holes and seat in the groove.
11. Turn each stud to secure guard to shaft.
12. Check that each guard turns freely on the shaft.
13. Assemble the driveline.
14. Check that the driveline telescopes easily.
15. Replace any components that are damaged or worn.
16. Install the driveline on the machine.

SERVICE AND MAINTENANCE



Guard Removal

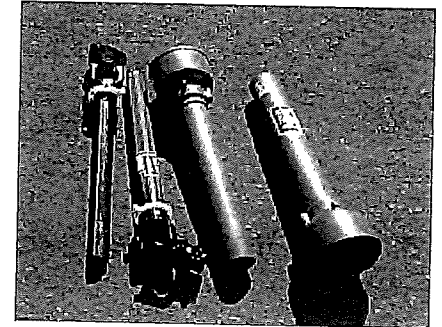

Disassembled

TROUBLE SHOOTING

The Bowell 3 Point Hitch Wood Chipper is designed with blades on a rotor to cut, shear and clip wooden material. It's a simple and reliable system that requires minimal maintenance.

In the following section, we have listed many of the problems, causes and solutions to the problems that you may encounter.

If you encounter a problem that is difficult to solve, even after reading through this trouble shooting section, please call your local distributor and dealer. Before you call, please have the Operator's Manual from your unit and serial number ready.

| PROBLEM | CAUSE | SOLUTION |
|---|---|--|
| Rotor does not turn. | Obstructed discharge. Rotor plugged. Broken shear pin. | Shut down and clear debris. Clear Rotor. Replace shear pin. |
| Slow feeding. | Knives are dull. Blade angle wrong. Improper angle. Discharge hood clogged. | Sharpen knives. Re-sharpen knives to specified angle. Clear discharge hood. |
| Chipper requires excessive power or stalls. | Obstructed discharge. Rotor plugged. Green material will not discharge. Dull knives. | Clear discharge hood. Clean Rotor. Allow material to dry or alternately feed in dry material. Sharpen knives. |
| High power requires. | Plugged rotor. Dull knives. | Clean Rotor. Sharpen knives. |
| Vibration while running. | Driveline vibration. | Check driveline phasing. Yokes must be aligned. Check rotor to see if it wobbles. Check to see if rotor is assembled correctly. |

SPECIFICATIONS

| Model | BX42S | BX62R |
|---------------------------|--------------------------------|--------------------------------|
| Drive System | Direct drive, pto w/shear bolt | Direct drive, pto w/shear bolt |
| HP Range | 18-50 | 30-100 |
| Engine | n/a | n/a |
| Chipper capacity | 4" Diameter, (max to 10" slab) | 6" Diameter, (max to 12" slab) |
| Chipper Housing Opening | 4" x 10" | 6 1/2" x 10" |
| Rotor Size | 25" | 30" |
| Number of Rotor Knives | 4 | 4 |
| Knife Type | Hardened Tool Steel | Hardened Tool Steel |
| Rotor Weight | 110 lbs | 180 lbs |
| Feeding System | GRAVITY FEED | HYDRAULIC FEED |
| Dimensions(hopper folded) | 40" L x 42"W x 60" H | 50"L x 52"W x 74" H |
| Hopper Opening | 20" x 20" | 25" x 25" |
| Discharge Hood Rotation | 360° | 360° |
| Discharge Hood Height | 60" | 74" |
| Rated RPM | 540-1000 | 540-1000 |
| Weight | 425lbs | 1070lbs |

SPECIFICATIONS SUBJECT TO CHANGE WITHOUT NOTICE

SPECIFICATIONS

BOLT TORQUE

CHECKING BOLT TORQUE

The tables shown below give correct torque values for various bolts and cap screws. Tighten all bolts to the torques specified in chart unless otherwise noted. Check tightness of bolts periodically, using bolt torque chart as a guide. Replace hardware with the same strength bolt.

ENGLISH TORQUE SPECIFICATIONS

| Bolt Diameter "A" | Bolt Torque* | | | | | |
|-------------------|------------------------|-----|------------------------|-----|------------------------|-----|
| | SAE 2 (N.m) (lb-ft) | | SAE 5 (N.m) (lb-ft) | | SAE 8 (N.m) (lb-ft) | |
| 1/4" | 8 | 6 | 12 | 9 | 17 | 12 |
| 5/16" | 13 | 10 | 25 | 19 | 36 | 27 |
| 3/8" | 27 | 20 | 45 | 33 | 63 | 45 |
| 7/16" | 41 | 30 | 72 | 53 | 100 | 75 |
| 1/2" | 61 | 45 | 110 | 80 | 155 | 115 |
| 9/16" | 95 | 60 | 155 | 115 | 220 | 165 |
| 5/8" | 128 | 95 | 215 | 160 | 305 | 220 |
| 3/4" | 225 | 165 | 390 | 290 | 540 | 400 |
| 7/8" | 230 | 170 | 570 | 420 | 880 | 650 |
| 1" | 345 | 225 | 850 | 630 | 1320 | 970 |

ENGLISH TORQUE SPECIFICATIONS

| Bolt Diameter "A" | Bolt Torque* | | | |
|-------------------|----------------------|------|-----------------------|------|
| | 8.8 (N.m) (lb-ft) | | 10.9 (N.m) (lb-ft) | |
| M3 | .5 | .4 | 1.8 | 1.3 |
| M4 | 3 | 2.2 | 4.5 | 3.3 |
| M5 | 6 | 4 | 9 | 7 |
| M6 | 10 | 7 | 15 | 11 |
| M8 | 25 | 18 | 35 | 26 |
| M10 | 50 | 37 | 70 | 52 |
| M12 | 90 | 66 | 125 | 92 |
| M14 | 140 | 103 | 200 | 148 |
| M16 | 225 | 166 | 310 | 229 |
| M20 | 435 | 321 | 610 | 450 |
| M24 | 750 | 553 | 1050 | 774 |
| M30 | 1495 | 1103 | 2100 | 1550 |
| M36 | 2600 | 1917 | 3675 | 2710 |

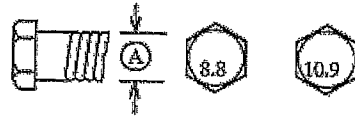
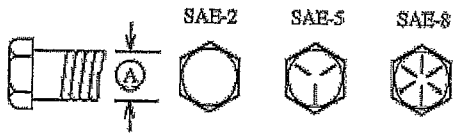

Torque figures indicated above are valid for non-greased or non-oiled threads and heads unless otherwise specified. Therefore, do not grease or oil bolts or cap screws unless otherwise specified in this manual. When using locking elements, increase torque values by 5%.

* Torque value for bolts and cap screws are identified by their head markings.

SPECIFICATIONS

HYDRAULIC FITTING TORQUE

Tightening Flare Type Tube Fittings

1. Check flare and flare seat for defects that might cause leakage.
2. Align tube with fitting before tightening.
3. Lubricate connection and hand tighten swivel nut until snug.
4. To prevent twisting the tube(s), use two wrenches. Place one wrench on the connector body and with the second tighten the swivel nut to the torque shown.
5. The torque values shown are based on lubricated connections as in reassembly.

| Tube Size OD (in.) | Nut Size Across Flats (in.) | Torque Value | | Recommended Turns To Tighten (After Finger Tightening) | |
|-----------------------|--------------------------------|--------------|---------|--|--------|
| | | (N.m) | (lb-ft) | (Flats) | (Turn) |
| 3/16 | 7/16 | 8 | 6 | 1 | 1/6 |
| 1/4 | 9/16 | 12 | 9 | 1 | 1/6 |
| 5/16 | 5/8 | 16 | 12 | 1 | 1/6 |
| 3/8 | 11/16 | 24 | 18 | 1 | 1/6 |
| 1/2 | 7/8 | 46 | 34 | 1 | 1/6 |
| 5/8 | 1 | 62 | 46 | 1 | 1/6 |
| 3/4 | 1-1/4 | 102 | 75 | 3/4 | 1/8 |
| 7/8 | 1-3/8 | 122 | 90 | 3/4 | 1/8 |

PARTS LIST

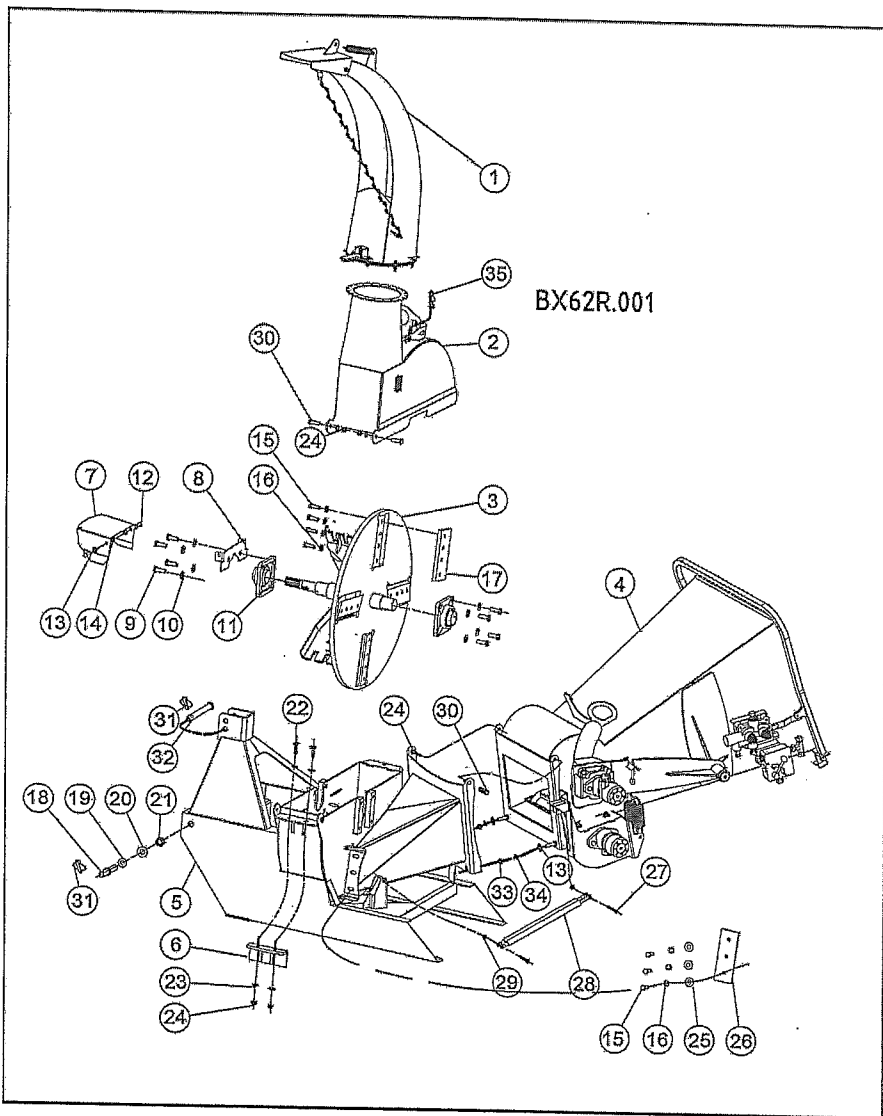

PARTS LIST

BX62R.001

| No. | Part No. | Name & Specification | | Qty |
|-----|---------------|---------------------------|---------------|-----|
| 1 | BX62.002 | Discharge pipe components | 出料口组件 | 1 |
| 2 | BX62.012 | Shell-on weldment | 上罩壳焊合 | 1 |
| 3 | BX62.013 | Cutter weldment | 刀盘焊合件 | 1 |
| 4 | BX62R.003 | Hopper assembly | 进料斗组合件 | 1 |
| 5 | BX62.011 | Base weldment | 底座焊合件 | 1 |
| 6 | BX62.014 | Side knife weldment | 侧刀焊合件 | 1 |
| 7 | BX62.102 | PTO cover | PTO罩壳 | 1 |
| 8 | BX62.101 | Bracket | 托架 | 1 |
| 9 | HBF14A1.25A45 | Bolts M14 * 1.25 * 45 | 螺栓M14*1.25*45 | 8 |
| 10 | PW14 | Washer 14 | 平垫14 | 4 |
| 11 | BUCF210 | UCF210 bearing seat | UCF210轴承座 | 2 |
| 12 | HBF10A25 | The M10 * 25 | M10*25 | 2 |
| 13 | PW10 | Flat pad 10 | 平垫10 | 2 |
| 14 | NN10 | Locknut 10 | 防松螺母10 | 2 |
| 15 | HBF12A1.25A30 | bolts M12 * 1.25 * 30 | M12*1.25*30螺栓 | 16 |
| 16 | SW12 | Spring Washer 12 | 弹垫12 | 16 |
| 17 | BX62.103 | Movable Knife | 动刀 | 4 |
| 18 | EFH175.105 | Lower pin | 下悬挂销 | 2 |
| 19 | SW22 | Spring Washer 22 | 弹垫22 | 2 |
| 20 | PW22 | Washer 22 | 平垫22 | 2 |
| 21 | HN22 | Hex nuts 22 | 六角螺母22 | 2 |
| 22 | HBF12A1.25A35 | Bolt M12 * 1.25 * 35 | 螺栓M12*1.25*35 | 2 |
| 23 | PW12 | Washer 12 | 平垫12 | 2 |
| 24 | NN12 | Locking nut M12 | 防松螺母M12 | 4 |
| 25 | PW12A3 | washer 12 * 3 | 平垫12*3 | 3 |
| 26 | BX62.104 | Fixed knife | 定刀 | 1 |
| 27 | HBF8A65 | Bolt M8 * 65 | 螺栓M8*65 | 2 |
| 28 | BX62.120 | Pneumatic spring | 气动弹簧 | 2 |
| 29 | NN8 | Locking nut M8 | 防松螺母M8 | 2 |
| 30 | HBF12A35 | Bolt M12 * 35 | 螺栓M12*35 | 4 |
| 31 | SP11 | Lock pin 11 | 锁销11 | 3 |
| 32 | BX42.101 | Upper pon | 上悬挂销 | 1 |
| 33 | HN10 | Hex nuts 10 | 六角螺母10 | 2 |
| 34 | SW10 | Spring washer 10 | 弹垫10 | 2 |
| 35 | RP4 | R pin 4 | R销4 | 1 |

PARTS LIST

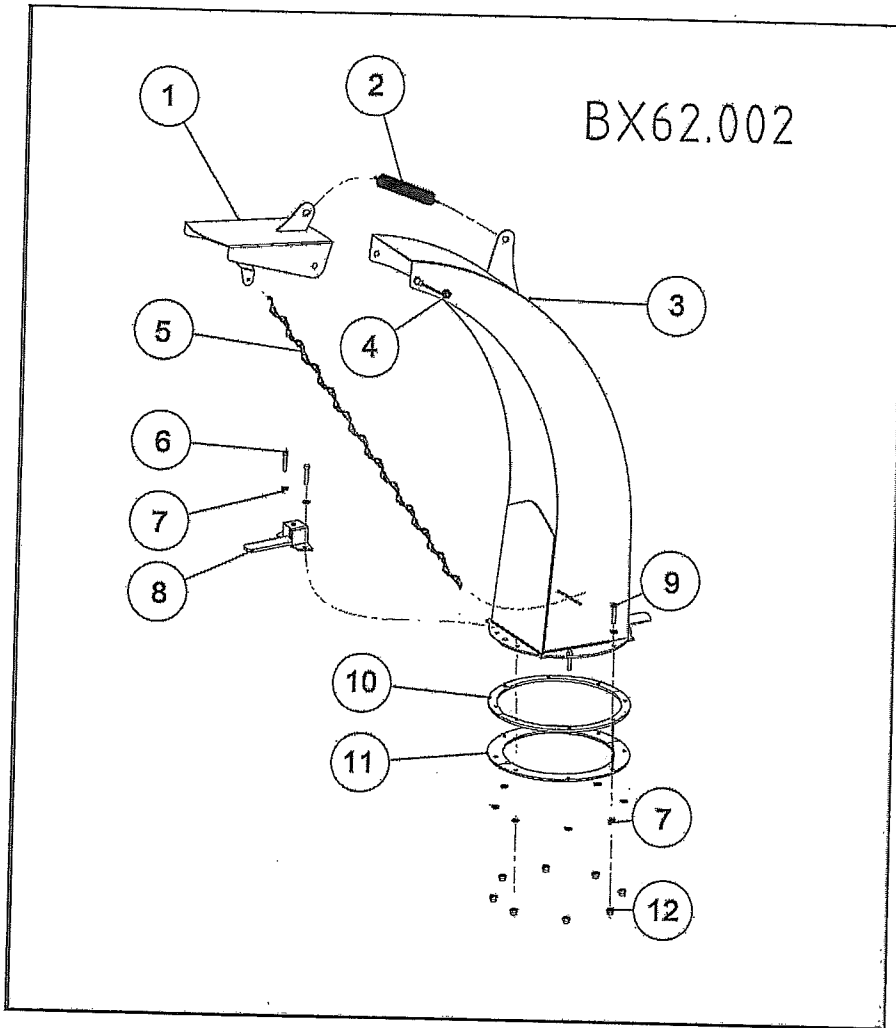

PARTS LIST

BX62R.002

| Ser.No | Part No. | Name & Specification | | Qty |
|--------|----------|------------------------|---------|-----|
| 1 | BX62.015 | Shield weldment | 出料口罩焊合件 | 1 |
| 2 | BX62.117 | Extension Spring 1 | 拉簧1 | 1 |
| 3 | BX62.016 | Discharge pipe welding | 出料口焊合件 | 1 |
| 4 | GX10 | Cap nuts 10 | 盖型螺母10 | 2 |
| 5 | BX62.118 | Chain components | 链条组件 | 1 |
| 6 | HBF6A35 | Bolt M6, * 35 | 螺栓M6*35 | 2 |
| 7 | PW6 | Washer 6 | 平垫6 | 16 |
| 8 | 20182 | Lock seat weldment | 锁座焊合件 | 1 |
| 9 | HBF6A30 | Bolt M6, * 30 | 螺栓M6*30 | 6 |
| 10 | BX62.115 | Middle Septa | 隔片 | 2 |
| 11 | BX62.116 | Lower Septa | 下夹片 | 2 |
| 12 | NN6 | Locking nut M6 | 防松螺母M6 | 8 |

PARTS LIST

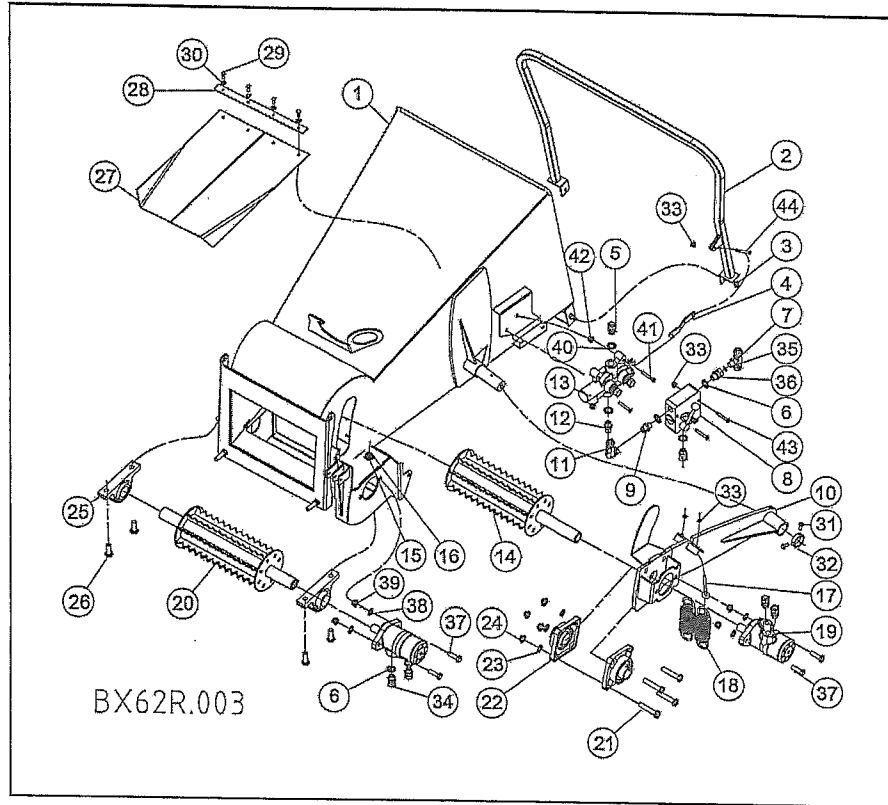

PARTS LIST

BX62R.003

| Ser.No. | Part No. | Name & Specification | | Qty |
|---------|----------|----------------------------------|---------------|-----|
| 1 | BX62.017 | Hopper weldment | 加料斗焊合件 | 1 |
| 2 | BX62.018 | Feed handle weldment | 进料手柄焊合件 | 1 |
| 3 | NN10 | Locking nut M10 | 防松螺母M10 | 2 |
| 4 | BX62.110 | Feed handle connecting plate | 进料手柄连接板 | 1 |
| 5 | BX62.305 | Switch Valve straight connector | 换向阀直接头 | 3 |
| 6 | BWG1/2 | Combination washer G1 / 2 | 组合垫圈G1/2 | 7 |
| 7 | BX62.307 | Tees | 三通接头 | 1 |
| 8 | BX62.312 | Control valve assembly | 调速阀组件 | 1 |
| 9 | BX62.301 | Control valve straight connector | 调速阀直接头 | 1 |
| 10 | BX62.021 | Pendulum shaft welding | 摆轴焊合件 | 1 |
| 11 | BX62.306 | Control valve fittings | 调速阀卡套接头 | 1 |
| 12 | BX62.302 | M18 connector | M18接头 | 1 |
| 13 | BX62.313 | Switch Valve | 换向阀 | 1 |
| 14 | BX62.019 | Upper roller weldment | 上滚筒焊合件 | 1 |
| 15 | NN16 | Locking nut M16 | 防松螺母M16 | 4 |
| 16 | PW16 | Washer 16 | 平垫16 | 4 |
| 17 | BX62.113 | Hook-type screw | 钩型螺钉 | 2 |
| 18 | BX62.112 | Extension Spring 2 | 拉簧2 | 2 |
| 19 | BX62.314 | Hydraulic motor | 液压马达 | 2 |
| 20 | BX62.020 | Lower Roller weldment | 下滚筒焊合件 | 1 |
| 21 | HBF14A70 | Bolt M14X70 | 螺栓 M14X70 | 4 |
| 22 | B UCF208 | B UCF208 bearing | UCF208轴承副座 | 2 |
| 23 | PW14 | washer 14 | 平垫14 | 4 |
| 24 | NN14 | Locking nut M14 | 防松螺母M14 | 4 |
| 25 | B UCP208 | B UCP208 bearing | UCF208轴承付座 | 2 |
| 26 | HBF16A50 | Bolt M16X50 | 螺栓 M16X50 | 4 |
| 27 | BX62.108 | Rubber baffle | 橡胶挡板 | 2 |
| 28 | BX62.109 | Layer | 压条 | 1 |
| 29 | HBF6A15 | Bolt M6 * 15 | 螺栓M6*15 | 4 |
| 30 | PW6 | Washer 6 | 平垫6 | 4 |
| 31 | HBF6A10 | Bolt M6X10 | 螺栓 M6X10 | 2 |
| 32 | BX62.111 | Block sets | 挡套 | 1 |
| 33 | NN6 | Locking nut 6 | 防松螺母6 | 5 |
| 34 | BX62.303 | Motor straight connector | 马达直接头 | 5 |
| 35 | OR10A2.5 | O-ring (inner diameter * 2.5) | O型圈(10内径*2.5) | 1 |
| 36 | BX62.304 | Valve straight connector | 阀直接头 | 1 |
| 37 | HBF12A45 | Bolt M12X45 | 螺栓 M12X45 | 4 |
| 38 | PW12 | Washer 12 | 平垫12 | 4 |
| 39 | NN12 | Locking nut M12 | 防松螺母M12 | 4 |
| 40 | BW18 | Combination washer 18 | 组合垫圈18 | 4 |
| 41 | HBF8A65 | Bolt M8 * 65 | 螺栓M8*65 | 2 |
| 42 | NN8 | Locking nuts M8 | 防松螺母M8 | 2 |
| 43 | HBF6A65 | Bolt M6, * 65 | 螺栓M6*65 | 2 |
| 44 | HBF6A25 | Bolt M6 * 25 | 螺栓M6*25 | 1 |

PARTS LIST

BX42 Parts

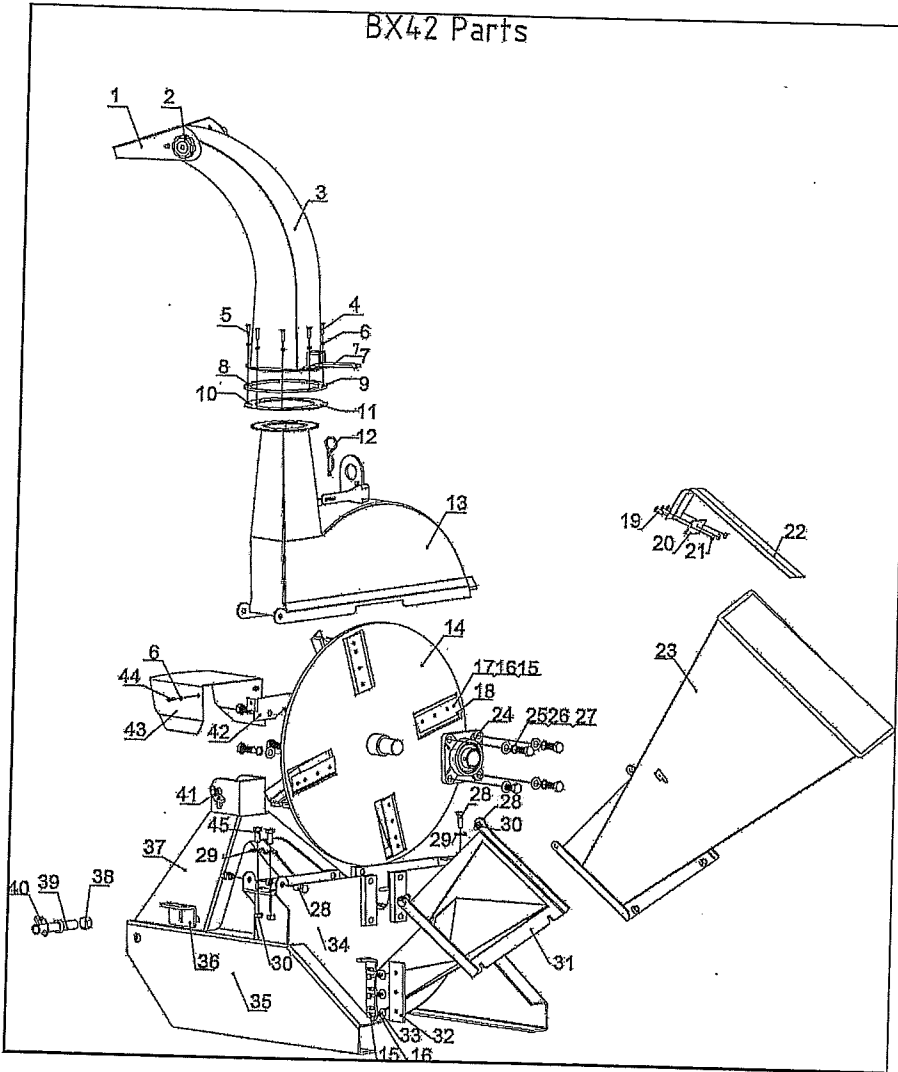

PARTS LIST

| No. | Part No. | Name & Specification | Qty |
|-----|---------------|-------------------------------------|-----|
| 1 | BX42S.103 | discharge hood | 1 |
| 2 | BX42S.114 | handel nut | 2 |
| 3 | BX42S.016 | hood neck | 1 |
| 4 | GB5782-86 | bolt M6*25 | 2 |
| 5 | GB5782-86 | bolt M6*20 | 6 |
| 6 | GB6184-86 | lock nut M6 | 10 |
| 7 | BX42S.018 | lock base | 1 |
| 8 | BX42S.112 | up splint A | 1 |
| 9 | BX42S.113 | down splint A | 1 |
| 10 | BX42S.110 | up splint B | 1 |
| 11 | BX42S.111 | down splint B | 1 |
| 12 | RP4 | R pin Φ4 | 1 |
| 13 | BX42S.013 | up rotor cover | 1 |
| 14 | BX42S.015 | rotor | 1 |
| 15 | GB5782-86 | bolt M8*20*1.25 | 16 |
| 16 | GB93-87 | washer A Φ8 | 19 |
| 17 | GB97.1-2002 | washer B Φ8 | 16 |
| 18 | 00021051 | Stationary Blade | 4 |
| 19 | GB/T 12-88 | rotor blade 1 | 3 |
| 20 | BX42S.106 | rubber plate A | 1 |
| 21 | GB6184-86 | lock nut M8 | 8 |
| 22 | BX42S.108 | rubber plate B | 2 |
| 23 | BX42S.011 | feeding hood | 1 |
| 24 | UCF208 | UCF208 bearing hub | 2 |
| 25 | GB97.1-2002 | washer A Φ14 | 8 |
| 26 | GB93-87 | washer B Φ14 | 8 |
| 27 | GB5782-86 | bolt M14*40 | 8 |
| 28 | GB5782-86 | bolt M12*30 | 5 |
| 29 | GB97.1-2002 | washer Φ12 | 3 |
| 30 | GB6184-86 | lock nut M12 | 6 |
| 31 | BX42S.012 | feeding hood neck | 1 |
| 32 | BX42S.104 | Stationary Blade | 1 |
| 33 | GB/T96.1-2002 | big washer Φ8*24*2 | 3 |
| 34 | BX42S.020 | down rotor cover | 1 |
| 35 | BX42S.014 | base | 1 |
| 36 | BX42S.017 | side plate | 1 |
| 37 | BX42S.019 | 3 point hitch suspension | 1 |
| 38 | GB6184-86 | lock nut M22 | 2 |
| 39 | EFH175.105 | 3 point hitch suspension bottom pin | 2 |
| 40 | SP11 | 3 point hitch suspension pin lock | 3 |
| 41 | BX42S.109 | 3 point hitch suspension top pin | 1 |
| 42 | BX42S.101 | bracket | 1 |
| 43 | BX42S.102 | driveline cover | 1 |
| 44 | GB5782-86 | bolt M6*16 | 2 |
| 45 | GB5782-86 | bolt M12*35 | 2 |

Bowell Implement Warranty

Warranty

Bowell warrants to the original purchaser that this **Bowell** product will be free from defects in material and workmanship beginning on the date of purchase by the end user according to the following schedule when used as intended and under normal service and conditions for personal use.

Overall Unit and Driveline: One year Parts and Labor

Gearbox: One year on all components.

Blades and Belts: Considered wear items.

This Warranty is limited to the replacement of any defective part by **Bowell** and the installation by the dealer of any such replacement part, and does not cover common wear items. **Bowell** reserves the right to inspect any equipment or parts which are claimed to have been defective in material or workmanship.

This Warranty does not apply to any part or product which in **Bowell's** judgment shall have been misused or damaged by accident or lack of normal maintenance or care, or which has been repaired or altered in a way which adversely affects its performance or reliability, or which has been used for a purpose for which the product is not designed. Misuse also specifically includes failure to properly maintain oil levels, grease points, and driveline shafts.

Claims under this Warranty should be made to the dealer which originally sold the product and all warranty adjustments must be made through an authorized **Bowell** dealer. **Bowell** reserves the right to make changes in materials or design of the product at any time without notice.

This Warranty shall not be interpreted to render **Bowell** liable for damages of any kind, direct, consequential, or contingent to property. Furthermore, **Bowell** shall not be liable for damages resulting from any cause beyond its reasonable control. This Warranty does not extend to loss of crops, any expense or loss for labor, supplies, rental machinery or for any other reason.

No other warranty of any kind whatsoever, express or implied, is made with respect to this sale; and all implied warranties of merchantability and fitness for a particular purpose which exceed the obligations set forth in this written warranty are hereby disclaimed and excluded from this sale.

This Warranty is not valid unless registered with **Bowell** within 30 days from the date of purchase by the end user.